

spatial interfaces

transitions between private and public in residential architecture

Erika Klein | Julia Svensson

Chalmers University of Technology | Department of Architecture and Civil Engineering

Examiner: Mikael Ekegren | Supervisor: Björn Gross

Spatial Interfaces

- transitions between private and public in residential architecture

Master's thesis 2021

Erika Klein and Julia Svensson

Chalmers University of Technology

Department of Architecture and Civil Engineering

Master's program: Architecture and Urban Design

Examiner: Mikael Ekegren | Supervisor: Björn Gross

Thesis studio: Building Tectonics



Abstract

A special Thank You

...to architect August Örling for contributing so generously with time, enthusiasm and wise reflections throughout the master's thesis process.

...to Professor Lars Marcus and the team from Social Ecological Urbanism for valuable guidance during the preparation course.

...to everyone who contributed with their personal *Interface Story*.

... and to our supervisor and examiner in the Building Tectonics direction, Björn Gross and Mikael Ekegren, for support and direction along the way.

This thesis is about interaction. In the urban spaces of the cities, public and private domains exist side by side. They can either strengthen each other by distinct borders, or have a dynamic relationship, whereas semi private or public situations may occur. The design of the buildings facing the street will affect the usage and character of it. This thesis investigates the spatial interface between private and public in residential architecture. Our aim is to find ways of design that create qualitative urban spaces and good private homes, and that promote social encounters in the space between the two.

The streets and urban spaces are to be perceived as public and inviting, with lively streets where people walk, stay and interact. The desired perception of a private dwelling is different. Here the resident is in control, feeling safe and free in his or her home. It is in the interface between the private dwellings and the urban spaces of the city, that smaller or bigger interactions take place, between the people who stroll the streets and the people who live their everyday lives in the building. An interface with a dynamic relationship between the public and the private space allows for a symbiosis between the two, where the lives of the residents sip out and enrich the urban space.

Our investigation is divided into two main parts. The first part summarizes previous research and investigations relating to the theme. The second part is a design project of a residential area in Gamlestaden, Gothenburg. Here we have implemented, concretized and refined the findings from the literature research. Our goal is to design a proposal with the best possible relation between the private and the public spaces. Conclusions from both parts are gathered in a design toolbox, consisting of seven practical strategies.

Keywords: public, private, residential architecture, street life

Content

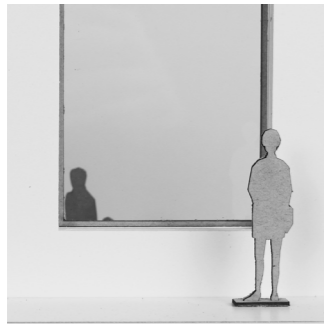

1. Introduction

Introducing the subject
Aim
Research question
Delimitations
Methods

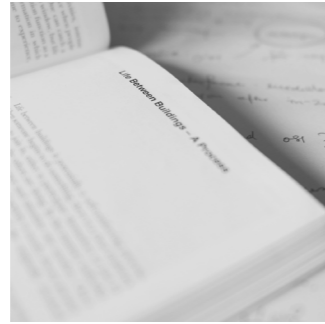

2. Written words

The dwelling
The border
The streets
Life in-between
Culture and climate
Social encounters



3. Interface Stories

Lisa
Robin
Andrea
Lisa
Sandra Kopjer
Lars Marcus
Nina Falk Aronsen

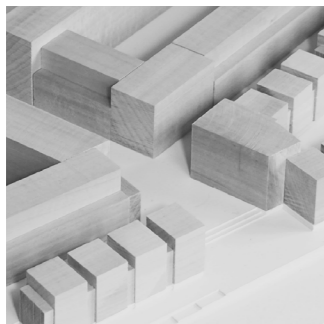

4. Design project

The site in Gamlestaden
Site plans and sections
Building typologies
Detail drawing
Floor plans
Model investigations
The 5 interfaces

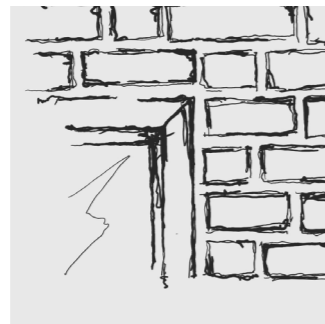

5. Design toolbox

Introducing the toolbox
Preconditions
Tools



6. Conclusion

Result and reflection
Bibliography
Illustration credits

1. INTRODUCTION

In the gap between residential architecture and urban space design, we found the spatial interfaces between the private dwellings and public urban spaces. This thesis will investigate those interfaces from two sides, working in the scale of the city, as well as the detailed scale of the urban private dwelling.

Architecture is about shaping space. The architect's challenge is to create qualitative spaces that bring value to its users and the surrounding spaces. In this thesis we are focusing on the challenge of creating both a qualitative urban space and good private homes, side by side. The design of the interface between the city and the urban dwelling will affect the usage and perception of both domains. The purpose of the interface is to fulfill the separate needs of both the people passing by or staying in the street, and the residents in their homes. The people in the street must feel like they have the full right to the public space, and are not intruding on the intimacy of the private homes. The residents need to feel secure and free in their private spaces, not exposed to the public outside. The architect's role here is to be the defender of both the street's and the home's interests. His or her task when designing the interface is to give the most possible value to both the private and the public sphere.

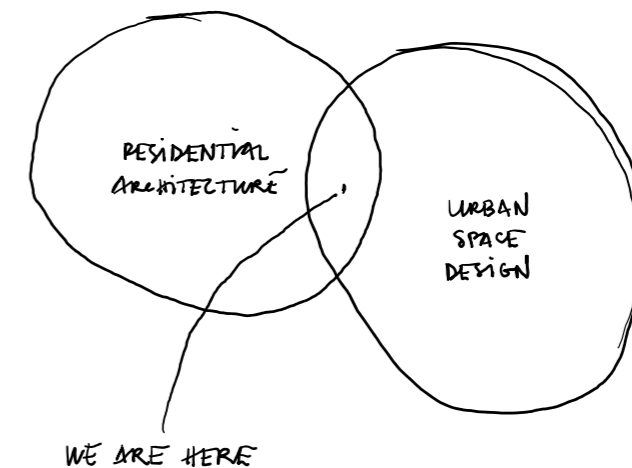

Aim

This thesis aims to find successful ways to design residential buildings with interfaces that create qualitative urban spaces and good private homes. Since every design project is unique, we will not find one general solution of the best possible relation between the public and the private spaces. Instead, we are aiming to create a toolbox with design strategies that affect the perception and usage of the private and the public space. The toolbox means to inspire architects and planners when designing residential architecture. Our findings will be tested and carried through in a hypothetical design project in Gamlestaden in Gothenburg.

Research question

How does the architectural design of interfaces between private and public territories affect the perception and usage of the two?

Delimitations

Gothenburg has been chosen for both the design project and the point of departure for the theory. Thereby this study will be limited to represent a Swedish culture and climate in a rather big city. The usage of public space and the desired relationship between public and private probably looks different in a smaller rural village or an area with "less public" public spaces. Furthermore, we have limited our research to focus on multifamily houses and row houses as urban residential buildings. The public places we are working with are mainly limited to streets.

The ongoing pandemic, caused by Covid-19, has limited the possibilities for longer travels, and therefore the physical case studies have been limited to Gothenburg. Studies of images, drawings and descriptions have represented the sites and projects where visits were not possible.

The background to the conclusions are based on a small survey, literature and general assumptions. The performed survey is qualitative and should not be viewed as general conclusions, as it does not represent a diverse group or society as a whole. A larger survey would have given a greater understanding of the subject. Theoretical references are chosen from the architectural discipline and do not represent all that is written in the field, but is rather a selection of well recognised authors.

There is much more to say about the spatial interfaces between private and public than what is represented in this thesis, both from an architectural perspective and a social point of view.

Methods

The work with this thesis has been carried out in multiple ways, and can be described as an iterative process, rather than linear. Throughout the semester, the chosen methods have been used parallelly and the conclusions and results from the different methods have evolved along the way. Following, the main work methods are described.

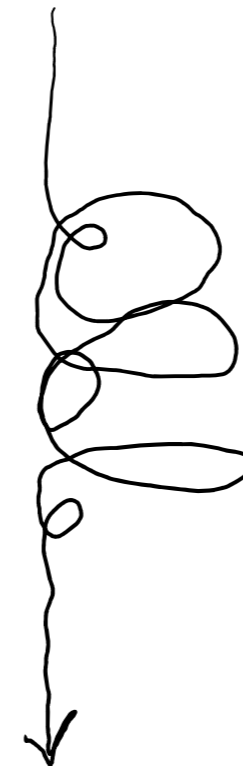

Literature studies

A study of existing theories relating to the field of research. Precious work from recognized authors, planners and architects like Jane Jacobs, Jan Gehl and Herman Hertzberger has been studied and brought into the knowledge bank of the thesis.

Interface Stories

Informal conversations with friends, teachers and fellow architects throughout the process resulted in a small qualitative survey that we call Interface Stories. Here, a mix of professionals in the field and regular residents in Swedish cities share their short views or personal experiences on life in the city.

Study of built references

Existing residential projects, streets and public spaces have been noticed, analysed and discussed throughout the process. They are examples from our everyday life in Gothenburg, memories from travels to other places, and due to the current situation with the global pandemic, observed on long and detailed street view strolls on Google Maps.

Design project

To concretize and test theoretical findings and conclusions from the methods above, a hypothetical design project has been carried out on a current parking space in the urban area of Gamlestaden, Gothenburg. The project has provided the useful challenge of adapting to a site. The design process included sketches, drawings, discussions, as well as digital and physical models. The physical models at scale 1:20 served as tools to evaluate and analyse the spatial conditions of our ideas. Research by design describes our approach to working with the project in Gamlestaden as part of our research and evaluation method.

2. WRITTEN WORDS

In this chapter we will go through previously performed research on the field and the factors that make the interface either well functioning, or unused. The theoretical references are mainly collected from the architectural discipline.

In an urban residential building the interface between the dwelling and the urban space of the city outside can be dealt with in numerous ways. In its most simple form, the physical facade of the building represents the interface, separating the private from the public. We call this type of situation a "hard interface" (fig. 1). By adding different levels and different placement of windows to the interface the relationship between the two domains becomes more dynamic and may invite for social encounters between the resident and the passer by (fig. 2). An interface with a gradual transition between the private and the public we call a soft interface. This is often implemented through a semi-private buffer zone between the street and the building. It can differ in size and character, and functions as a social zone, a possibility for interaction between the private and the public (fig. 3). To give the most possible value to both the private and the public situation, the architect needs to have two perspectives in mind when designing the interface. This needs to be done with fine balance and precision. (Gehl, 1976)

Figure 1:

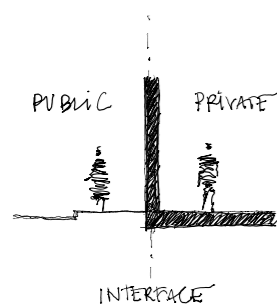

Figure 2:

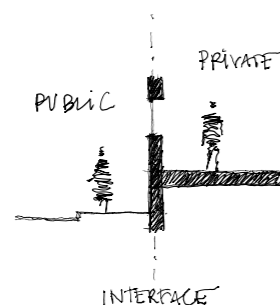
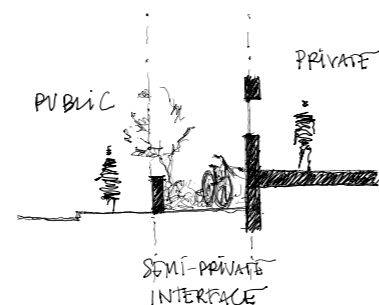

Figure 3:



The border

The spatial interface between the dwelling and the city is not just any place, it constitutes the important border between two different territories where different ownership and rights rule, the private and the public territories. Within architectural theory the word territoriality is used to describe how streets, buildings, squares, parks, sidewalks etc. are divided into areas or zones with different belonging and access. Between the different zones occurs a spatial hierarki, from the very public places, that everyone can access down to the more private entities which is the area of the individual (Kärholm, 2004)(Minoura, 2016). Often, this hierarki is divided into the four categories; public, semi-public, semi-private and private. This gradient however, is in many cases too simplified since two semi-public areas can be of different publicity and have different territorial belonging and access.

Through different codes we mark these different territories so that they can be associated with a specific group of people, administration, behavior, person or culture. If people feel territorial towards a place they will take ownership over it and leave traces indicating what kind of belonging the place has. Some examples of this can be a chair, a flowerpot or a grill. Some key-factors decide how a place will be claimed, used and territorialised (Minoura. 2016):

- » The access to the territory. This becomes most clear in the cases of courtyards of residential blocks where some are accessible only for the residents, while some are open for the local neighbourhood as well.
- » How many that have access to an area in relation the size of the area. A small space that a large group has access puts high pressure on the space.
- » Who has control over the area. Both the informal control that the residents have over the front yard, which increases if they have many windows towards the area and direct access to it. And, the formal control, that is about regulating access and transparency to an area and thereby excluding unwanted visitors.
- » The boundaries or the interface between the different zones. That can include and unite different territories or exclude.

This way of dividing the city into territories may sound rival and excluding, but it helps us to organise our behavior and lets us understand what is accepted and expected behavior in a place. On a warm summer day one may go out to the green area outside the apartment and sunbathe in just a bikini, while that behavior

The figures illustrate plans of three different building typologies. The first shows a building where the outdoor space is divided into private, semi-private, semi-public and public spaces. The second building lacks private outdoor space and the last has only semi-public and public space outside of the building.

Figure 4:

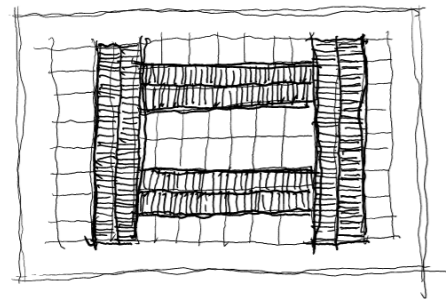

Figure 5:

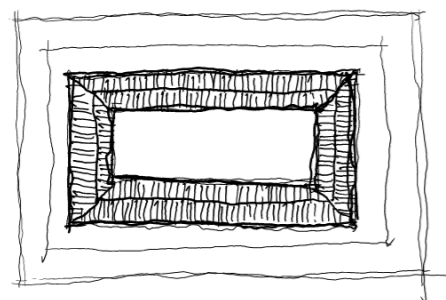
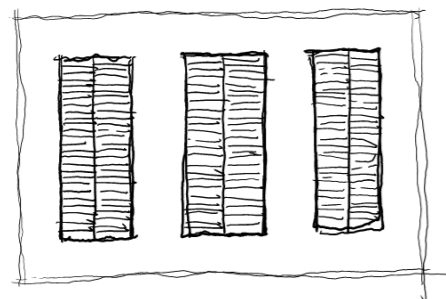

Figure 6:



would never be accepted on the main square, as the two places have different territoriality. In areas where the belonging is vague, there is a risk for conflicts between different groups claiming the place, or that the area becomes unclear and unused (Minoura, 2016). With this argument Eva Minoura argues in her book "Bostadsgården - Territoriell arkitektur" for spaces with a territorial clarity between areas with different belongings (Minoura 2019). One could argue that outdoor spaces around residential buildings that are accessible for everyone are welcoming and enjoyable, but the risk is that it comes at the cost of the residents' privacy and feeling of safety. Instead of an open and accessible space the residents might take the matter into their own hands and put up signs, fences and gates with port codes.

Henceforth, there is a close connection between the building typology of the street and the territorial division of the area. Different building typologies and different site plans will define the space around the building in different ways, resulting in more or less territorial division. This becomes most clear when comparing the housing blocks from the 19th century (fig. 4-5) with the freestanding multifamily buildings from the second half of the 20th century (fig. 6). The latter lacks the semi-private zone of the courtyard of the blocks, where neighbors can be recognised and distinguished from strangers. (Minoura, 2016)

The dwelling

The private side of the interface is the dwelling. It is important that the interface is designed so that the dwelling is perceived as private. For an apartment in a dense urban environment where the concentration of people is high, the size of the windows has a great impact on the perception of the dwelling. Many residents would feel uncomfortable and exposed in a home with too big windows facing a street with a high flow of people. This issue has much to do with breaking sightlines and offering the resident a place where the public outside cannot see his or her activities inside the home. This can be solved by actions such as decreasing the window size, highering the window sill, or elevating the floor from the street outside.

The degree of transparency between the dwelling and the outside is a fine act of balance. Too small windows will not let enough daylight into the apartment and eliminate its outlooks and connection to the world outside. The architect Jan Gehl and the psychologist Kaya Roessler were invited to a danish radio program to have a conversation about how much our homes affect us. At the end of the program the moderator asked them what kind of living situations are bad for mental health. The architect and the psychologist had a quick and united answer: the ones where one is locked in, isolated and without meetings. Both saw the risk in living isolated and alone without the connection to the world outside and the possibility to follow what others do. Jan Gehl even argued that it is much easier to build homes that isolate than to build homes that both isolate and invite the possibility for smaller or bigger interaction. (Brinkmann, 2020)

The street

On the other side of the interface we have the public space. When thinking of the public places in the city, one may first think of the squares or public parks. While that is of course correct, the streets and sidewalks are actually the main public spaces of our cities. They are our way to work, where we walk, bike, stop for a chat and do our everyday errands. And maybe most importantly, our homes are situated along the streets. When streets and sidewalks are designed with the ambition of creating qualitative urban space, beautiful and well functioning cities will occur. In her book "The death and life of great American cities" Jane Jacobs states it clearly: "Think of a city and what comes to mind? Its streets. If a city's streets look interesting, the city looks interesting; if they look dull, the city looks dull." (Jacobs, 1961)

Streets and sidewalks have the obvious purpose of facilitating transportation and giving access to buildings, but in the best scenario, they also carry other functions. A well functioning street can prevent crime, provide sunny spots for taking a break and promote social encounters between neighbors, as well as strangers. (Jacobs, 1961)

In her book, Jacobs states three premises/conditions for a well functioning safe urban street. Her first point is regarding the borders between public and private space. In an urban setting, it is of great importance that it is clear what spaces belong to the public, and what spaces that might be private. Secondly, Jacobs speaks about 'eyes on the street'. If a public place can be overlooked by for example residents or shop owners, it is perceived as

safer, and will also be less affected by street crime (Jacobs 1961). The focus of this thesis is not to prevent crime through architectural design. However, the aspect of street safety is relevant here, as it is directly connected to how streets are being used. A safe street is commonly well used, and an unsafe street is likely to become deserted, since people will not choose to pass or stay there, if they are not obligated to do so. (Jacobs 1961)

The third condition is for the sidewalk to be continuously populated. The reason is simply that people attract people. But also because it adds 'eyes' on street level, and awakens the residents' eyes, and gives them more reason to pay attention to the neighboring sidewalk life. Frequently spread out stores, bars and other public facilities will also give people reason to stay in the street. Though bear in mind that these types of commercial activities need to be supported by a certain amount of by-passers in order to make ends meet financially. (Jacobs 1961)

It may seem like some streets or even cities just 'got it', but the truth is, street or sidewalk life does not appear magically. It rises as a result of certain base conditions connected to location and flow of people, combined with concrete, sensitively managed and considered physical details (Jacobs, 1961). A study of the influence traffic has on the occurrence of outdoor activities was carried out in San Francisco in 1970-71 by Appleyard and Lintell (Gehl, 2006). Three neighbouring streets, with a modest rate of traffic, were

studied before and after the traffic volume increased. The result showed that on the street with the greatest increase in traffic volume the outdoor activities almost disappeared and they could see a reduction of neighbour contacts. On the streets with only a little traffic, outdoor activities still filled the urban space with children playing, people sitting on the steps and good contact between the neighbors (Gehl, 2006). It seems like simple improvements of the physical space of the street such as reducing the traffic, planting greenery or placing benches make the usage of the street increase remarkably.

The traffic of the street is connected to the degrees of publicity of the street. The overall structure and form of the city plan decides how the flow of people is distributed in the city. A street that is highly connected to other streets and places and thereby a part of a greater spatial context will have a higher flow of people than a street with low connectivity, for example a cul-de-sac. The flow of people decides in turn how public the street is perceived. When a high flow of people from other places in the city visits the street it will be perceived as very public. And vice versa, a street with very few visitors per day will give the perception of a private place. The flow of people on the street might be the most determining factor for how the interface will be treated in the residential buildings along the street. A very general rule is, that the bigger the flow of people is on the street, the harder the interface needs to be (L. Marcus, personal communication, 3rd of March, 2021).

Life in-between

One way to enrich both the public and the private side of the interface is to actively work with the concept of street life. The Danish architect and urban planning professor Jan Gehl, embraces this subject in his well read book "Life Between Buildings", first written in 1971. The already mentioned journalist and theorist Jane Jacobs was also a great influencer on the subject, mainly through her book "The Death and Life of Great American Cities" from 1961. Among other things both Gehl and Jacobs argue that the human presence on streets is of great importance for the way the streets are perceived and used. (Gehl, 2006) (Jacobs, 1961)

In a study in Ontario, Canada, 1977, Jan Gehl recorded outdoor activities in residential areas. In the study he measured different types of activities taking place on the porches, front yards and streets of row houses and detached houses. Among other things, he divided the activities into 'coming and going activities', that in most cases were the necessary activities like going to school or work and running errands, and 'stationary activities', that often were optional like training, going for a walk, taking a coffee in the sun or just sitting on a bench. As a result of his study, Gehl concluded that if the number of activities and their duration were combined, 'coming and going activities' stood for 10% of the total outdoor activities. The remaining 90% were represented by 'stationary activities'. (Gehl, 2006)

When planning residential areas and designing homes, the planner or architect has a significant influence over the time spent outdoors by the residents. Jan Gehl saw in his studies that easy access in and out, good staying areas directly in front of the house and something to do or work with directly in front of the house, were three factors that can increase outdoor time and thereby make a livelier and more pleasant neighborhood. Design that encourages people to go to a place and use it can be something as simple as a bench in front of a sunny wall. For many people the garden can serve the same purpose, encouraging them to be outdoors. A garden in a nice location is likely to be used also for social activities and recreation. (Gehl, 2006)

Gehl could also see that the architectural quality and detailing of the physical environment affected the usage of the space. "When carefully detailed, outdoor spaces stand a good chance of being functional and popular. If detailing is careless or absent altogether, the battle will inevitably be lost". Since the 'coming and going activities' are necessary they take place throughout the year, independent of both season and the quality of the physical space. The 'stationary activities', on the other hand, were dependent on both the quality of the physical space and favorable exterior conditions. In the cases where outdoor space was of poor quality almost no 'stationary activities' occurred. (Gehl, 2006)

Culture and climate

To what extent streets are used by its residents depends just as much on contemporary norms and culture, as on the physical environment. When Jan Gehl banned cars from Strøget in Copenhagen 1962, many doubted his visions of a south european "plaza" filled with outdoor seating. They could not imagine how this would be established in a cold nordic city. Today, Strøget is a schoolbook example of city planning with humans in the center. (Gehl, 2004)

The borders between private homes and public places are found all over the world. Travels around the globe show us a wide range of examples of how the two spheres can relate to each other. The insight and understanding of a new city can be inspiring and raise interesting questions. However, the aspects of both culture and climate must always be taken to account, when analyzing an unfamiliar example. Matters such as social norms, religion, views on privacy and the approach to other people vary around the planet, and even within countries and urban areas. As this thesis is set in a Swedish context, we need to have the Swedish people, culture and climate in mind when designing. What are the swedish people like? What are the preferences and expectations of the private home or the urban street here? However, like already stated, a foreign reference can be of great value and inspiration.

For us, a relevant source of inspiration has been dutch cities like Amsterdam and Rotterdam. When walking in dutch urban areas, we have found the private - public interfaces to be very interesting. In many cases, the residential

buildings firmly shape the streets, with what at first sight would seem like a "hard interface". However, two things strike us about these situations. One relating to physical form, and the other to behavior and usage. The first is all the private entrances, linking the dwellings directly to the street. In some cases the dwelling has a floor level of approximately one meter above the street level. In these cases a small platform with stairs usually gives access to the apartment. In this thesis we will refer to these particular platforms/stairs with the dutch word, "stoep". We also found them in American settings in for example New York under the same (imported) word, stoop.

Connecting to these recurrent entrances and stoeps, something special about the usage and approach to the street has been noticed. The residents seem to have an engaged relation to the outdoor space, and 'claim' the street through placing furniture, bikes and plants in the usually narrow interface between the street and the building. It gives the impression of enriching both the life in the street and the dwelling itself, and also implies a sort of trust in the neighbours and passersby.



The everyday lives of Amsterdammers sipping out on the public street.

Social encounters

Throughout this journey towards finding and defining good interface spaces, it cannot be denied that people and social interactions are key aspects in some way. But what is it about these social encounters? And what do they have to do with architecture?

According to the dutch architect Herman Hertzberger, architecture and social life are strongly connected. In an interview with Architecture and Education he brings up several examples where architecture serves as a tool for bringing people together. One of the examples mentioned is the window. "This is about connection - when you make a window, you have an outlook. An outlook means you try to be in connection. Connection, basically for me, lies in space as to see and to be seen." Further in the interview, Hertzberger comes down to talking about the situation of the street and the dwelling. "I remember from my youth that I was playing in the street all the time and there you learn about the world, about the bad guys and the good guys and you have your front door always at hand. When things are too delicate or too risky, you can go back to the house. Or your mother can shout out "It's time to eat!". There's a direct relationship between the dwelling and the street whereas today there's a sort of complete distance." (Wood, 2017)

An important question to ask is whether these social encounters are only in the interest of planners and architects, or if they are actually what people, the users, of the public spaces want? When speaking of the social encounters in the built space, Hertzberger does not seem to doubt the fact that they are desirable by

When it comes to using public space and spending time outdoors, climate plays a great deal. A survey was made, measuring pedestrian street activity in Copenhagen. As winter turned into summer from January to July people walking on the streets doubled in number. During the same period the amount of people standing tripled, and the number of people sitting went from zero in the coldest period to a significant amount as the days got warmer. The result showed that well situated benches started being frequently used at a temperature of 10°C. (Gehl, 2006)

Jan Gehl describes Scandinavians' relation to the sun as a "special love affair". After a long dark winter the populations of northern countries like Sweden are eager to go out and catch the spring sun. An accessible exterior wall in the right angle quickly fills up by people enjoying the long awaited weather (Gehl, 2006). The sought aims when planning urban spaces in a Scandinavian context are to take advantage of the sun and to avoid the wind. In both of these aspects walls can be a key element. People in general also tend to like to stay in zones close to walls and facades, when using public space. The phenomena is sometimes called "the edge effect", and was called out by the sociologist Derk De Jonge. Gehl argues, in architecture and planning, that if the edge works, so does the space. Interestingly enough, the interfaces studied in this thesis are situated right in this type of edge zone, which if the theories above are to be trusted, should generate good opportunities for a livelier atmosphere and usage of the space. (Gehl, 2006)

3. INTERFACE STORIES

people. He goes as far as (with a humorous tone) questioning whether the main function of schools is really to teach formal subjects like mathematics, or if it rather functions as the space for interacting socially, even flirting, with other students. (Wood, 2017)

The American sociologist William Whyte also seems confident in the idea that people tend to be drawn to others. However, in his book *The Social Life of Small Urban Spaces*, he distinguishes contradiction between the actions of people, and what they say they want. "What attracts people most, it would appear, is other people. If I belabor the point, it is because many urban spaces are being designed as though the opposite were true, and that what people liked best were the places they stay away from. People often do talk along such lines; this is why their responses to questionnaires can be so misleading. How many people would say they like to sit in the middle of a crowd? Instead they speak of getting away from it all, and use terms like "escape," "oasis," "retreat." What people do, however, reveals a different priority." (Whyte, 1980)

Whyte also inclines that there is a close connection between the physical form of an urban space, and the usage of it. One example of this is the correlation between people sitting, and places to sit. The more opportunities there are to have a seat in a public place, the more people will actually sit down. (Whyte, 1980)

The architect and the sociologist are coherent in the conclusion that built space is an important utensil for social life, even though people might not admit it. With that conclusion in mind, Hertzberger values the threshold as a very important part of, and connection between, the street and the private dwelling. Again he uses the picture of the little child that, sitting on the threshold knows that his mom is near, and at the same time is out in the big world. For this child, the threshold is the space where the safety of the home and the adventures of the outside world, overlap. Hertzberger claims that the spatial quality of the threshold is an element in its own and is the place where the resident is most open for social interactions with strangers. Therefore, one could argue that the spatial interface between the private dwelling and street has an importance for the social interactions of the residents and passers by. (Hertzberger, 1991)

The first part of the following chapter is the result of a small qualitative survey, where four residents in Swedish cities describe their personal experiences of the interface between their home and the street outside. The second part contains three reflections from professionals within the fields of architecture and urban design, relating to the subject of these interfaces. All stories are written by the participants themselves in Swedish.

A big part of this thesis is to raise the question of how architects work with the spatial interface between private and public. Through the process we noticed that the field of study was a real conversation starter. Every home has an interface to the street and the urban space outside and many have a reflection or an opinion about the interaction they have with "the world outside" in their home. Some were disturbed by the noise and insight from passers by, while others had stories about conversations and meetings with neighbours, or reflections over why the design of the spatial interface was such an important task. We decided to collect these stories and add them to our research, as they represent the real users of the city and its dwellings.



Photo 1: Aronsen, N. F.

Lisa

Resident in Änggården, Göteborg

Jag och min man bor i ett radhus i Änggården i Göteborg. En av de bästa sakerna med vårt boende är vår lilla förträdgård i söderläge på framsidan. Vi har ställt dit ett bord och några stolar och brukar sitta där och fika, äta lunch eller läsa en bok när det är soligt. Folk som går förbi på gatan lyser ofta upp när de ser oss och ofta är det någon som stannar och pratar eller säger "vad härligt det ser ut" (hände senast idag). En av de första helgerna som vi satt där kom vår närmsta granne förbi bara för att berätta att de har hur mycket trädgårdsverktyg som helst som vi får låna hur mycket vi vill. Så nu har vi kunnat klippa häcken och gräsa upp i rabatterna tack vare honom och att den öppna stämningen mellan husens förträdgårdar.

"Me and my husband live in a row house in Änggården in Gothenburg. One of the best things about our house is our small front yard on the front side in the south. We put out a table and some chairs, and usually we sit there eating fika or lunch, or reading a book in the sun. People passing by on the street smile when they see us and often someone stops for a chat or just to say "That looks wonderful" (happened today). One of the first weekends we sat there, our closest neighbor came by just to tell us that they have many garden tools that we can borrow as much as we need. So now we've been able to trim the hedge and pull the weeds thanks to him and the open atmosphere between the front yards of the houses".



Robin

Resident in Johanneberg, Göteborg

"Mycket folk passerar framför mina fönster när de ska till kiosken nämt. Det är störande när förbipasserande kan se in, så jag brukar ha persiennerna neddragna."

"Many pass by my windows when visiting the shop next door. It is disturbing when passers by can see into my apartment, therefore I usually have my blinds down."



Andrea

Resident in Majorna, Göteborg

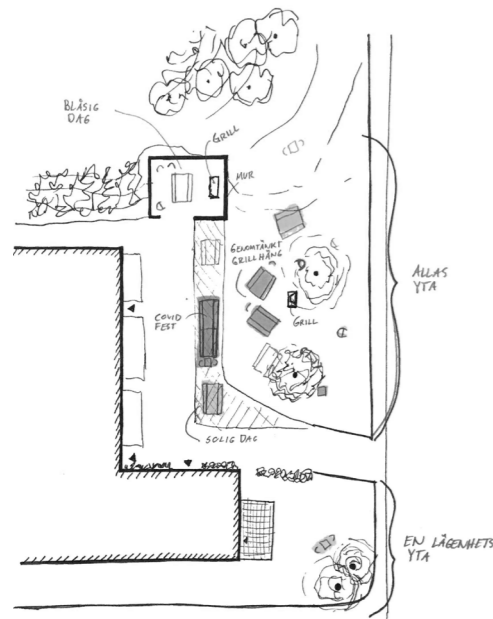

"I live in a studio apartment in Majorna. Since no one has a balcony, the courtyard is frequently used. There are never organised activities for the residents, but the residents often bring their guests there. Something I strongly like is that everyone in the building seems to feel an ownership over the courtyard. Not necessarily that everyone feels that "it is mine", but people dare to move things around so that it suits their purpose..."

Jag bor i studentlägenhet i Majorna. Eftersom ingen har balkong används gården flitigt. Det sker aldrig organiserade "hushåll" utan alltid i sällskap av "egna gäster". Något jag gillar skulpt är att alla i huset verkar känna ett ägandeskap för gården. Inte nödvändigtvis genom att känna att den är "min", men man vågar flytta på saker så de passar just mitt ändamål. Hyreshuset står för två parkbänkar och två fasta grillar, som har andra ställt dit mer stolar och bord. Från ena dag till en annan har gården arrangerats om. Bläste det igår står många möbler i de skyddade mörka områdena. Var det väldigt selt är alla möbler utställda där många hyresgäster var ute samtidigt och naturligtvis inte ville sitta tillsammans. Ibland är alla bord ihopdragna, speciellt under COVID då alla föreläsningar m.m. hölls etc. Andra gånger sker planerade, gemensamma grillningar med vimplar och "rökbord".

Jag älskar att se hur gården lever genom att ut som bar här vågar nyttja den. Det blir en påminnelse om att detta är vår gård, precis lika mycket som alla andras!

Lisa

Resident in Stockholm

"To sit on the couch and listen to all the conversations outside the window. It leaked in through the ventilation, and the thin window glass."

Att sitta i soffan och lyssna på alla samtal utanför fönstret. Det läcker in genom ventileringen, och den tunna rutan.

Sandra Kopjar

Associate senior lecturer at the Department of Architecture and Built Environment, Lund University

Mitt exempel handlar om privat/offentligt utifrån en situation utanför mitt hus på Mårtens Fälad här i Lund, ett vanligt villaområde där en stor del byggts under 1960-talet.

Vi hade det såhär pga av att vi hade jättetrevliga grannar tvärs över gatan och bredvid vårt hus. Genom att ställa ut ett bord och stolar på framsidan (västerläge) mot gatan ökade kontakten med just dessa grannar och andra som passerade förbi. Ofta satt vi och fikade under dagen eller drack ett glas vin tillsammans med grannar framåt kvällen. När vi någon gång grillade kom en annan granne som vi inte brukade umgås med och var arg för att det osat in i hennes kök. En kommentar som man aldrig fått om man grillat bakom huset, dvs i den större, "riktiga", trädgården. Barnen utökade

sin sfär och lekte och spelade fotboll på gatan. Bilderna är från 2007 och min dotter var 6 och min son 10 år. Det handlade nog mycket om att de kunde få en viss frihet om vi befann oss i närheten. Jag flyttade ifrån detta hus för en månad sedan och situationen har inte varit så här trevlig på 10 år. Som ett svar på fråga 2, varför frågan om privat och offentligt är en viktig fråga så tror jag att mitt exempel talar för att uppkomna situationer inte handlar endast om arkitektur och planering utan minst lika mycket om rådande normer. Jag tror också att offentligt/privat inte är något statiskt (som i mitt exempel) utan möjligheter som uppstår och försvinner varför arkitekten bör tänka på att skapa möjligheter för dessa situationer att finnas, om andra omständigheter tillåter detta.



Photo 3: Kopjar, S.

Lars Marcus

Professor Urban Design and Planning, Chalmers University of Technology

Denna gräns är viktig inom stadsbyggandet eftersom det kanske är den viktigaste gränsen vi har i samhället. Det mesta i politiken handlar om var gränsen skall dras mellan den privata friheten och ansvaret och de gemensamma intressena. Denna gräns manifesteras sig på ett fascinerande konkret sätt i våra städer och vi kan även se hur den flyttats genom att studera dess rörelser över tid. I de täta stadskärnorna, till stor del anlagda och byggda på 1800-talet, är gränsen mycket tydligt dragen och ger upphov till det vi brukar kalla kvarter. I efterkrigstidens stadsdelar är den helt frånvarande så att all mark förefaller tillhöra alla. Båda reflekterade de samhällsideal och maktförhållanden som vi hade vid båda tillfällena. Det stadsmässiga stadsbyggandet vi sett mycket av sedan 80-talet blandar detta på ett märkligt sätt med kvartersbebyggelse som ofta saknar tydliga gränser mellan privat och offentligt, vilket också säger något om vår samtid. Som stadsbyggare måste man ha en förståelse för att man förvaltar denna gräns och manifesterar den för mycket långa tidsperioder, det är helt enkelt att förstå vad stadsbyggnad handlar om.



Photo 2: Marcus, L.

Det man mer tekniskt behöver tänka på när det gäller denna gräns är att den inte bara skapas på den enskilda platsen som en gräns manifesterad på ett eller annat sätt mellan privat och offentligt utan även är en systemeffekt av människors rörelser i staden. Vi kan säga att en plats är offentlig men den blir inte performativt en offentlig plats om inte människor från andra platser besöker den, då är risken snarare att den över tid kommer att privatiseras av människor som bor i närheten. I vilken grad människor från andra platser besöker den beror i hög grad om platsen ingår i ett rumsligt sammanhang som gör den till del av olika flöden i staden. Det gör att olika platser regelbundet passeras av lågt säga 2, 20, 200 eller 2000 personer per timme. Detta är helt avgörande för om platsen verkligen skall upplevas som offentlig och i vilken grad den är offentlig. Om platsen besöks av 2 personer i timmen spelar det inte någon större roll hur väl vi manifesterar gränsen mellan privat och offentligt, den offentliga platsen kommer att upplevas som tämligen privat. Dessa flöden styrs i högre grad av just stadsbyggande genom den form och struktur vi ger stadens övergripande stadsrum och är därför ett viktigt ansvar för stadsbyggaren. Inte minst viktigt att då se är hur utformningen och karaktären på den enskilda platsen, inte minst dess offentlighet, i hög grad skapas av hur stadsrummet är format i helt andra delar av staden.

Nina Falk Aronsen

Lecturer at the Department of Architecture and Built Environment, Lund University

Kina 1985

Gatorna används som ett vardagsrum: Samtal, lek och vila. Här utförs också arbete i form av sömnad, matlagning och lagning av prylar. Interiörerna anas mörka innanför förhängen och trappstenar. Gaturummet är möblerat med lägre möbler av bambu, där inte minst den äldre generationen sitter. De har koll på de lekande barnen. TV-apparater är inte vanliga men finns de så delas de med andra i det gemensamma exteriöra vardagsrummet. När mörkret sänker sig skapar det blåaktiga skenet från de små 14-tumsskärmarna ljusrum, och hallåans röst ekar mellan väggarna. Gatan blir inte lika tydligt en utsträckning av det privata hemmet, utan mer en gemensam angelägenhet, ett gemensamt rum.

För mig, då 1985 (uppvuxen i svenskt villamråde), var detta ett helt nytt sätt att bo och leva. Sättet att luckra upp och skapa längre sekvenser mellan det privata och publika rummet upplevde jag förundrat som så mycket mer generöst. Generöst för mig som besökare och fullt av valmöjligheter för den som bodde på platsen. Hur mycket berodde denna expansion av det privata ut i det publika av utrymmesbrist? Hur mycket berodde den på ett behov av mer komplexa sociala mönster? Hur mycket av det ovan beskrivna har försvunnit idag och till vilket pris?

Cefalù, Sicilien 2002

Vi bor vid en smal gata i den gamla delen. Genom en port rör man sig in i kvarteret. Här på en liten gård har vi hyrt rum av en gammal dam. Vi har bara "goddag-nickat" till henne. Hon håller hov sin balkong utåt gatan och själva affärerna hanteras av hennes son. Hennes revir expanderar alltså ut i gaturummet en våning upp. Precis som alla de andra matronernas. Från detta skikt i gaturummet kontrolleras allt. Dagarna i ända kommenterar och diskuterar de vad som händer på gatan – och i världen. Samtalen ropas fram och studsar under hela dagen mellan väggarna.

Vid ett tillfälle köper jag en så kallad Zucca, en ca 1 meter lång zucchini av den mobile grönsakshandlaren som rullar nerför gatan på sin trehjuliga minilastbil. Jag frågar på stapplande italienska hur jag kan tillaga den. Detta utlöser en våldsam debatt i gaturummets övre regioner. Ska en Zucca tillagas med citron eller vitlök? Gatan är lång och åsikter om hur zuccan bör tillagas bollas fram och åter mellan väggarna i det smala rummet. Den upprörda diskussionen får fasader att falla. Jag backar in på min gård och in i mitt kök. Fem minuter senare så kommer min värdinna invaggande, nedstigen från balkongen, muttrandes "Adesso basta". Hon visar mig prompt hur man tillreder en Zucca. En vecka senare är det dags att lämna stan. På väg till järnvägsstationen, en bra bit från vår gata, frågar plötsligt en farbror mig:

- Hur gick det?
 - Vadå?
 - Zuccan!
 - Vaddå?
 - Zuccan!
 - Ahh. Con limone (med citron).
- Då mulnade han.

Östergårdsgatan

Utanför vår entrédörr mot gatan står ett bord och två stolar. Hit tar jag med mig kaffet, boken och kanske några tankar. Andra tar en cigarill. Man kan luta sig bakåt och nästan bli ett med väggen bakom vilken vårt sovrum ligger. Man kan se till sidorna och se vem av grannarna som är ute. Vinka. Ropsnacka. Få lite koll. Man kan lyfta blicken och möta världen. Betrakta den. Begrunda den. Kanske t o m inleda ett samtal med någon förbipasserande.

Vi bor på Östergård, Malmös första storgårdskvarter. Kvarteret är omgivet av gator med mycket olika karaktär. Mot två av dem vetter förutom trappuppgångar privata entréer. Det är uppenbart att gatornas skala, användning och material påverkar hur de används som en förlängning av det privata eller inte.

Södra Bulltoftavägen är en gata som leder långt. Den har enahanda hårda material. Trottoarer av betongsten, cykelbana av asfalt, kantsten av granit och själva gatan asfalt. Parallella långa remsor av material. Fasaderna på båda sidor med nåt undantag 3 - 4 våningar. Rummet upplevs som stort och monotont. Bilar tenderar att köra för fort. Här finns inga möbler i gaturummet.

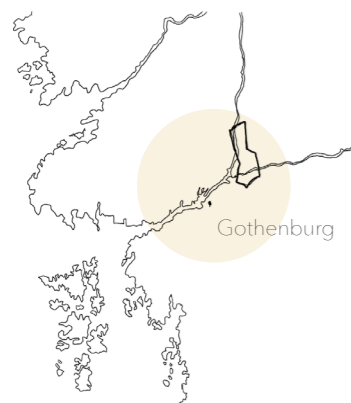

Photo 4: Aronsen, N. F.

Östergårdsgatan är en mycket kort gata och tillika enkelriktad, så trafiken är bara genomgående i en riktning. Körbanorna delas dessutom av en rad träd och parkeringar, vilket bryter ner skalan. Gatan är belagd med asfalt. Trottoaren har fin röd singel. Varje entré markeras med en tvärgående yta av betongsten. Våra hus är 3 våningar. På andra sidan finns lägre hus med lite förgårdsmark. Här finns en hel del möbler i gaturummet. Här finns också lite planteringar, krukor, etc. Hur gaturummet är formgivet och hur kopplingen mellan bostad och gata ser ut har stor betydelse för användningen så klart och naturligtvis spelar väderstrecken stor roll också. Vår fasad vetter mot sydsydost. Mitt emot oss är det sällan man ser någon som sitter i utanför huset. Men å andra sidan ser man ingen som hänger på Södra bulltoftavägens solsida heller... Skala, mångfald av material och väderstreck gör alltså Östergårdsgatan till ett bra ställe att vara om man bor på Östergård. I gestaltningen av gaturummet flätas det privata och det publika ihop av den mycket anspråkslösa betongplattetytan framför varje entré. Den tillhör både det privata och det publika och öppnar upp för fler flätningar. Det blir lätt att appropriera hörnet som uppstår mellan betongyta och fasad. Här sitter man gott i solen.

4. DESIGN PROJECT

The following chapter will display the design project in Gamlestaden Gothenburg. The process of design has been used as one of several research methods within the thesis. Different proposals were evaluated through drawings, discussion and the building of physical models.



To concretize and refine our design toolbox even further we have implemented the theoretical findings in a design project of a residential area in Gamlestaden, Gothenburg. To be able to work with multiple streets and a wide range of buildings and spatial interfaces, we chose a site with space for 2-4 building blocks. Our design is on different scales. There is the big scale, where we shape the residential area from the ground. On the small scale we work in detail with the different interfaces from an eye level perspective. We believe that design decisions in both scales will affect the perception and usage of the public space in-between the buildings and of the dwellings. In reality the same actor rarely gets to shape a project in all scales, like we do here. However, we strongly believe that for the interface between private and public to be successful, it must be taken into account both in the detail plan, and in the building design.

The site we have chosen is located in Gamlestaden, Gothenburg. This particular area provided the right urban setting and central location that was needed for our project. In the design we have been inspired by the industrial history of the area and by the river, Sävån, crossing the area. The project makes the water in the area more accessible and gives the inhabitants of Gamlestaden a public place to hang by the water.



Mapping of Gamlestaden, Gothenburg

Shaping a neighbourhood, step by step

1. Preconditions

Today, the site is a big parking lot, with a mild slope down towards the green and leafy borders of Sävån.

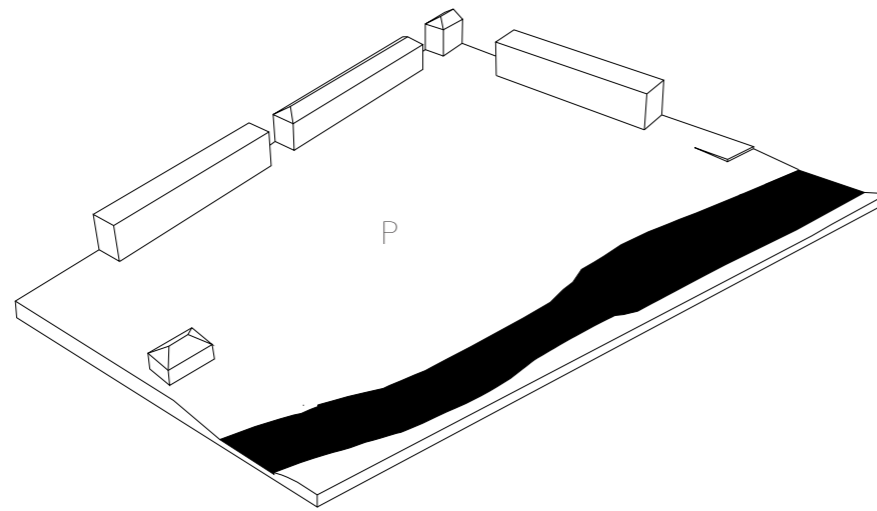

2. Topographic concept

In our proposal we take advantage of the levels in the topography by creating two platforms on different heights, separated by a wall. The higher platform will carry the added buildings and has an urban character. The lower platform is a riverside park close to the water, going down from the new bridge that is to be built over Sävån.

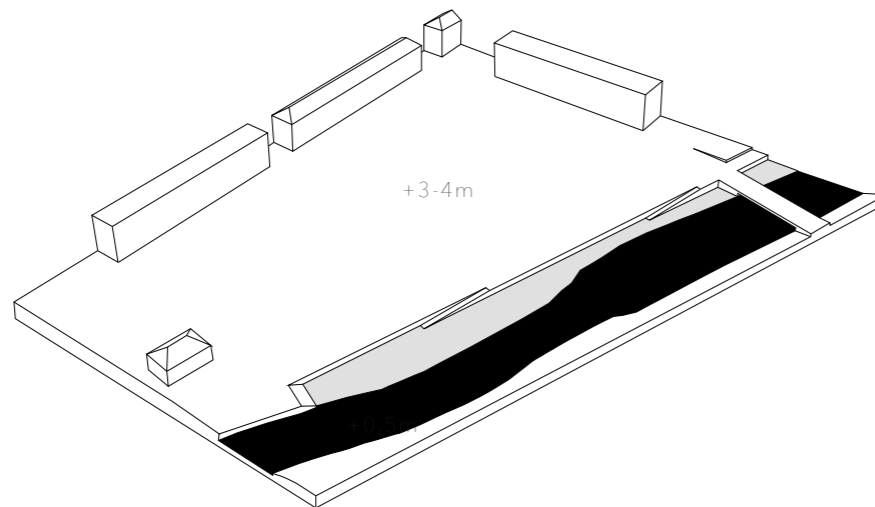

1. Street network

The new street network on the site is connecting to surrounding streets as much as possible. Depending on the desired character and flow of people on the new streets they are either straight or crooked. Sightlines and viewpoints are thoughtfully considered in the street network.

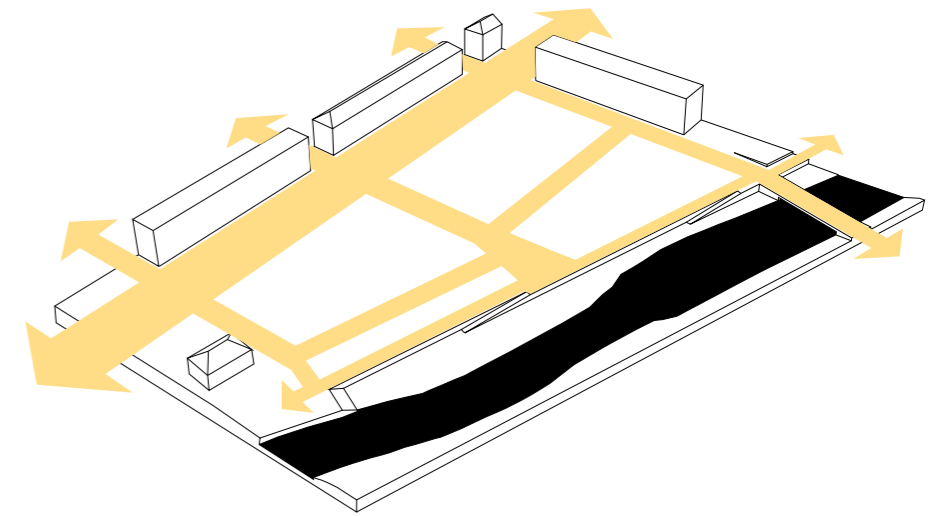

4. Forming buildings

The added buildings are three blocks and one separate structure. The heights vary between 3 and 6 floors. The buildings are higher along the busier streets, in the north, and aim to match surrounding structures.

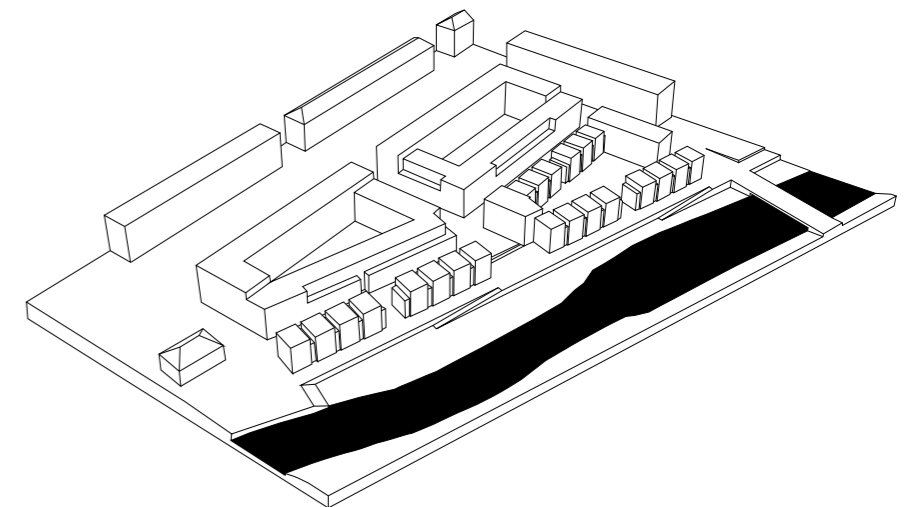

5. The final design

In the final proposal we are carefully breaking up the volumes, working with terracing and different scales depending on street types and flow. The variety in streets and volumes will provide different interfaces to be developed further in the project.

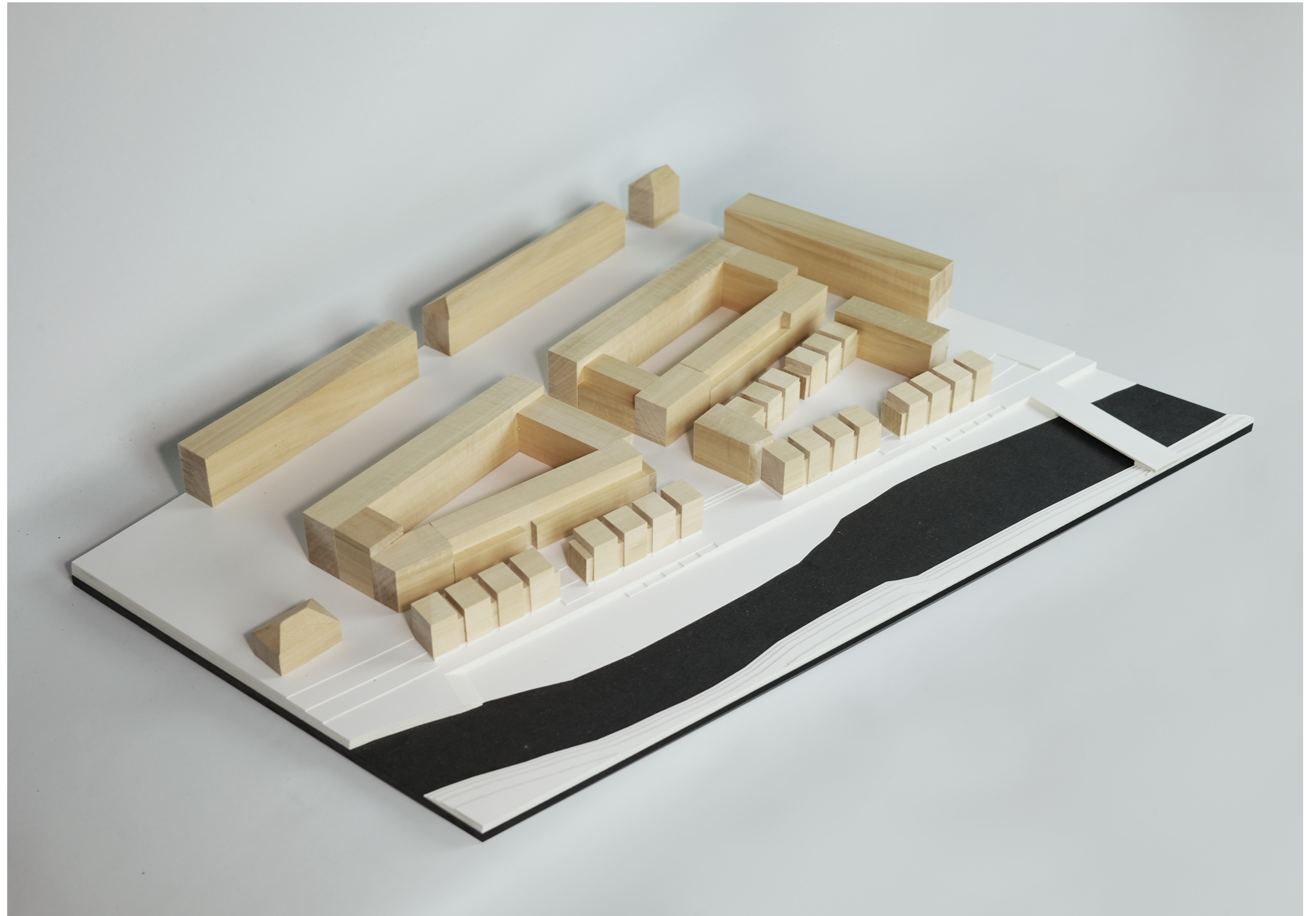

Site plan, 1:800

1:800

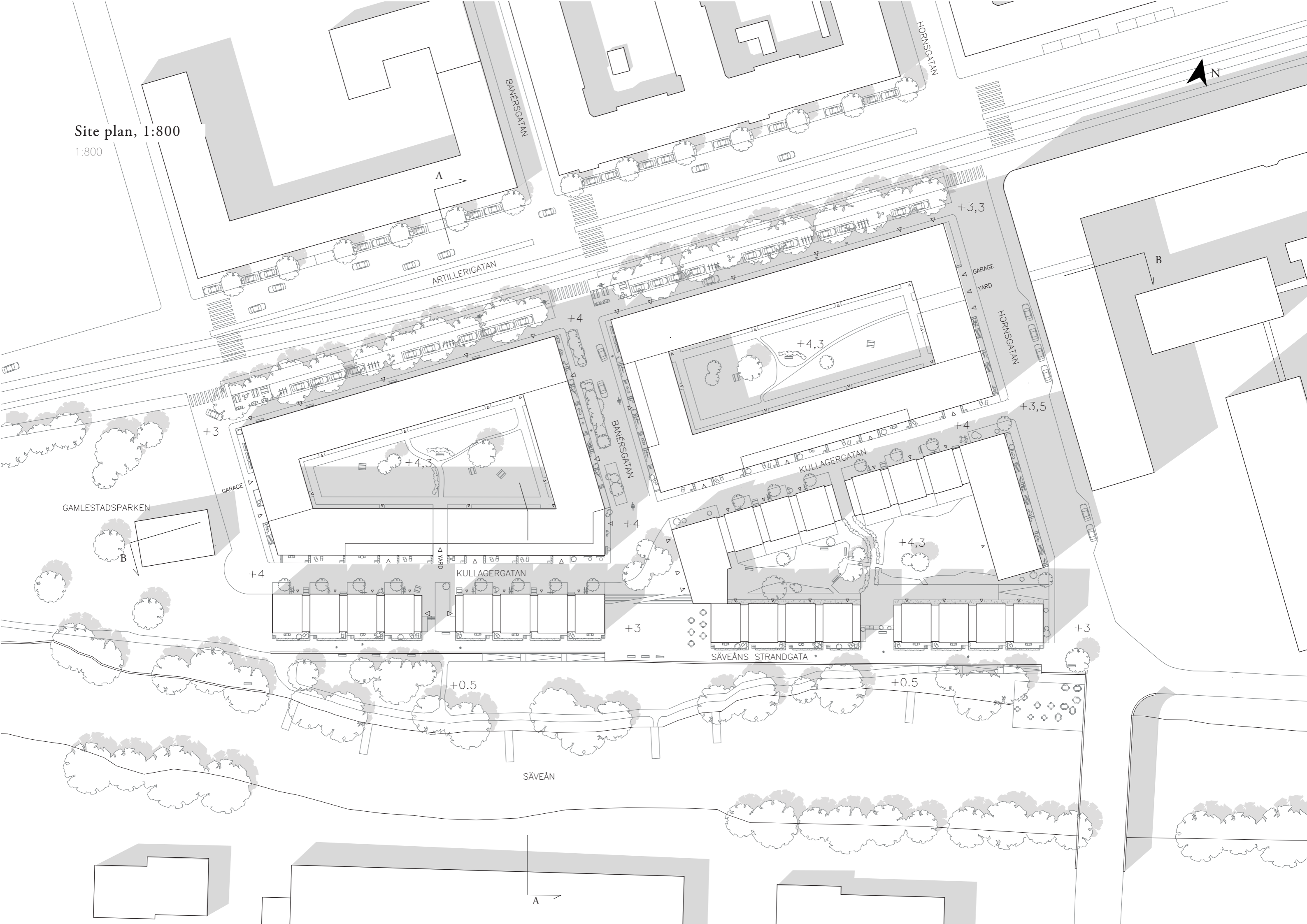

Site sections

1:800

The building height of the area is scaling down as one gets closer to the water. The different sides of the houses provide different urban preconditions for the interface along the street. In the site plan and section we have zoomed in on five situations which we have continued to study and develop, we call them the five interfaces. The desired perception and usage of the urban space and dwelling around each interface has then been the base for the design of the buildings.

Section A-A

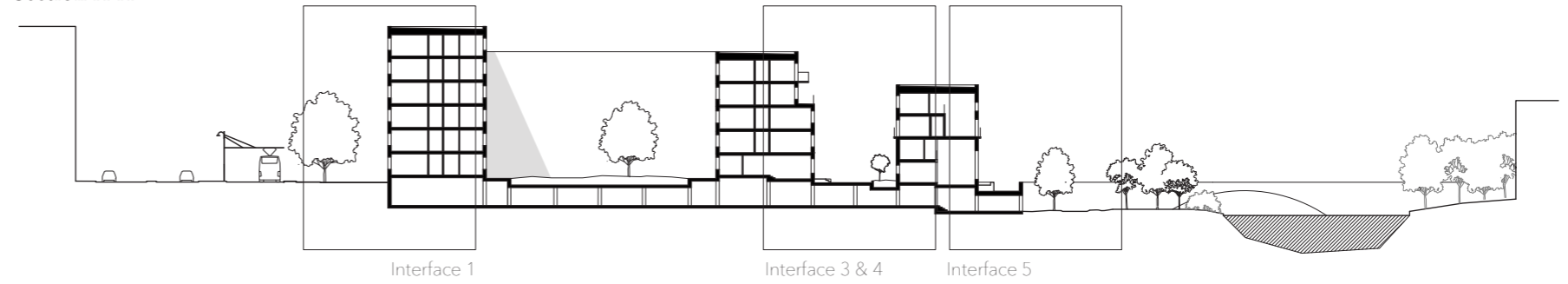

Section B-B

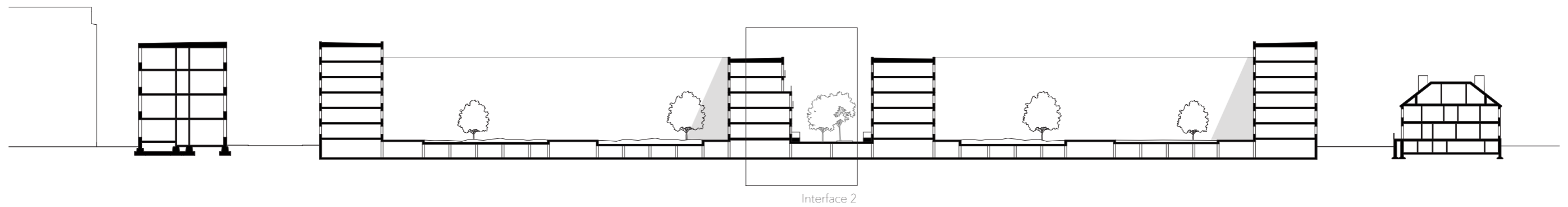

Building typologies

The area consists of two different building typologies. On the north side of the site, two typical housing blocks with private yards are placed. In a rational way, the block volume is divided into smaller apartment modules, each with one entrance and a vertical communication. The plan concept of the apartment module is based on a grid that marks the position of the interior walls. Some of the apartments on the first floor of the blocks have direct access to the street. In the more narrow streets of the area we wanted to work with a terraced building that breaks down the perceived scale of the building. Therefore we have developed two versions of the apartment module (module 1 and 2). In module 2 the elevator is pushed back to give space for the terrace and a room in-between.

South of the blocks lies one free standing structure and a block composed out of smaller town houses. Each townhouse consists of a typical row-house on the first two floors, and two apartments on top of it. One is a small studio apartment and the other is a larger one with two floors. A vertical communication on the gables gives access to an interior corridor on the third floor from where the upper two apartments can be reached. The townhouse typology gives the street a smaller scale and increases the entrances and semi-private spaces in front of the houses.

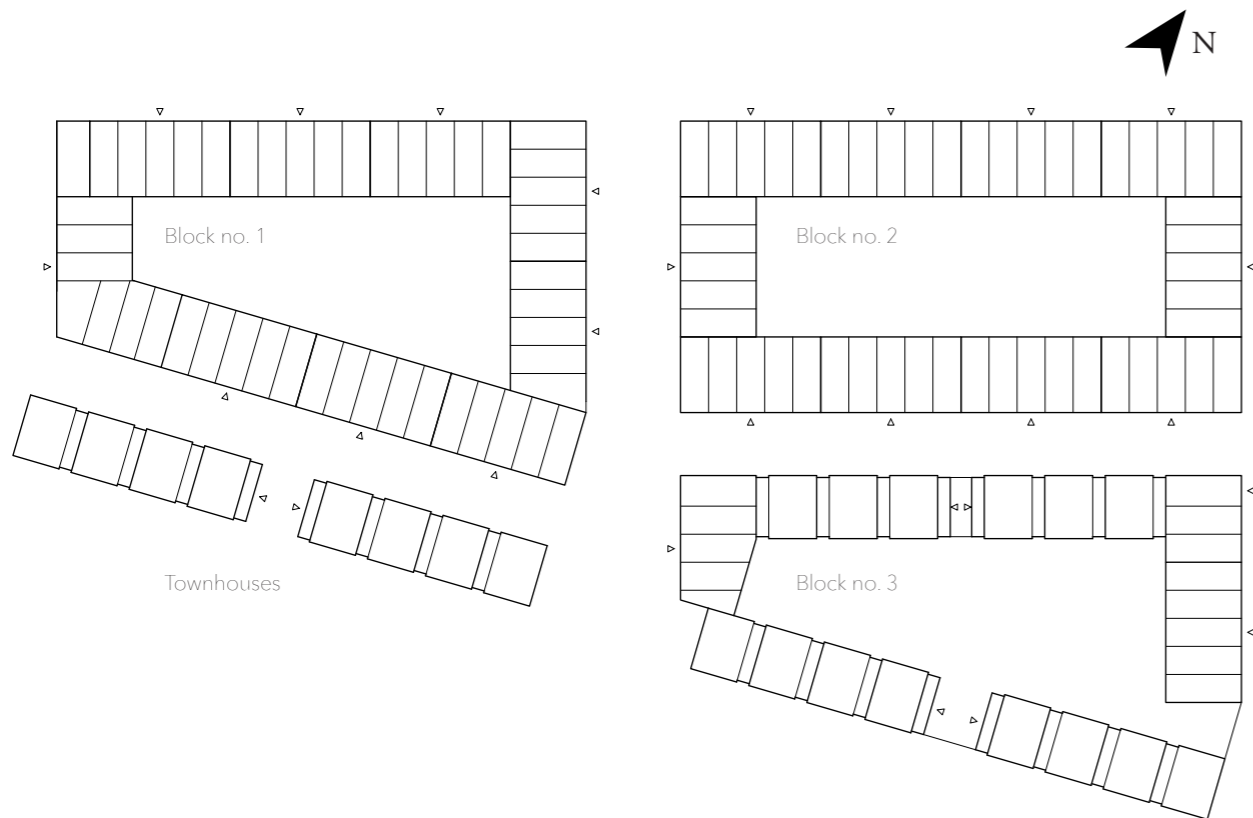

Apartment module plan concept, 1:200

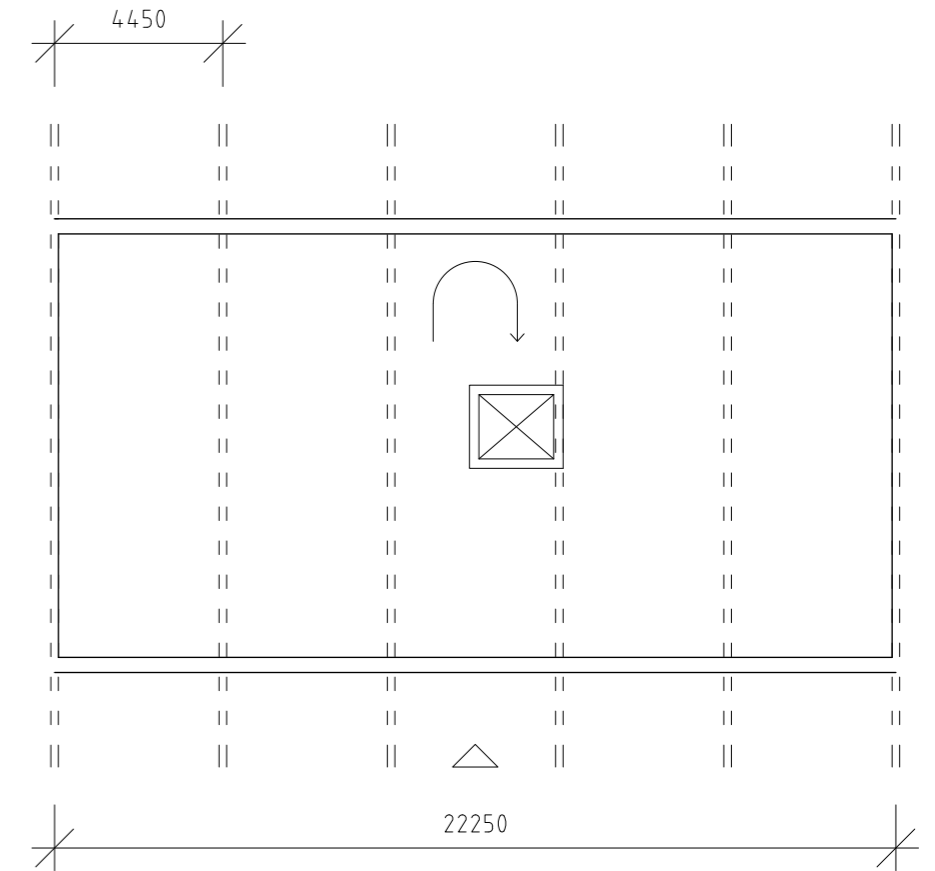

Townhouse section, 1:200



Block module, type 1

drawings, 1:200

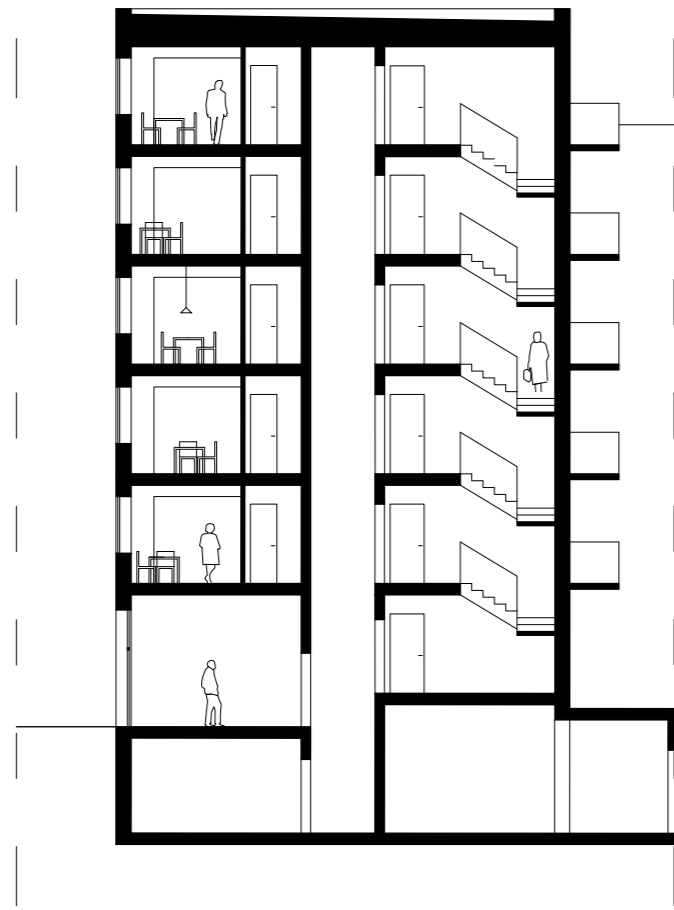

Section D-D

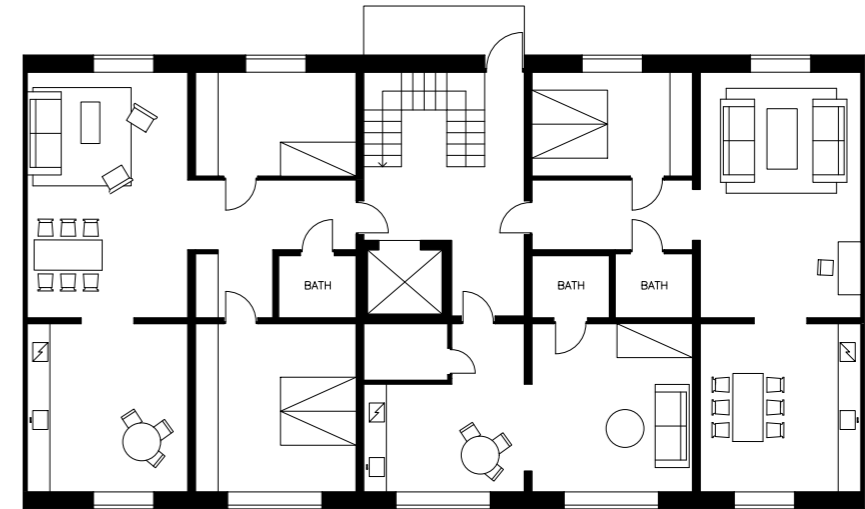

Floor 2-6

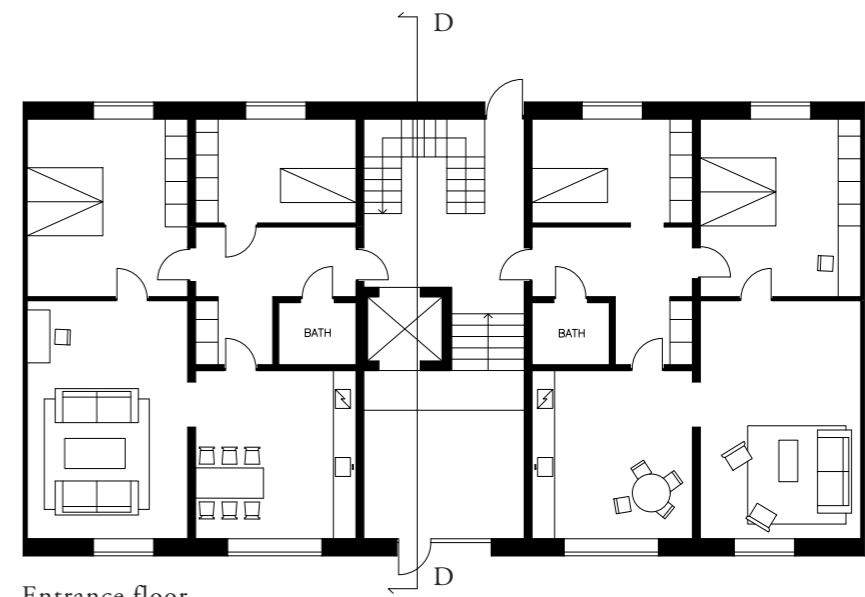

Entrance floor

Block module, type 2

drawings, 1:200

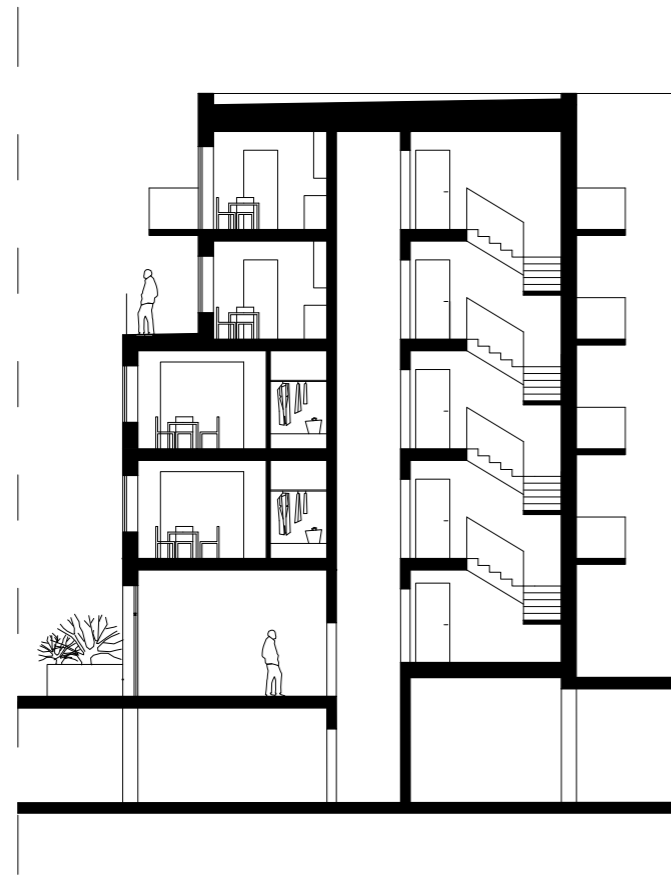

Section E-E

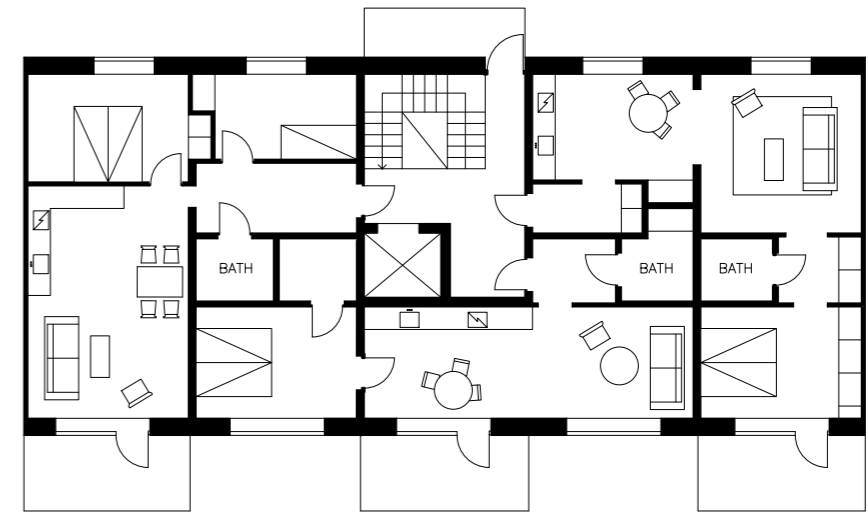

Floor 4-5

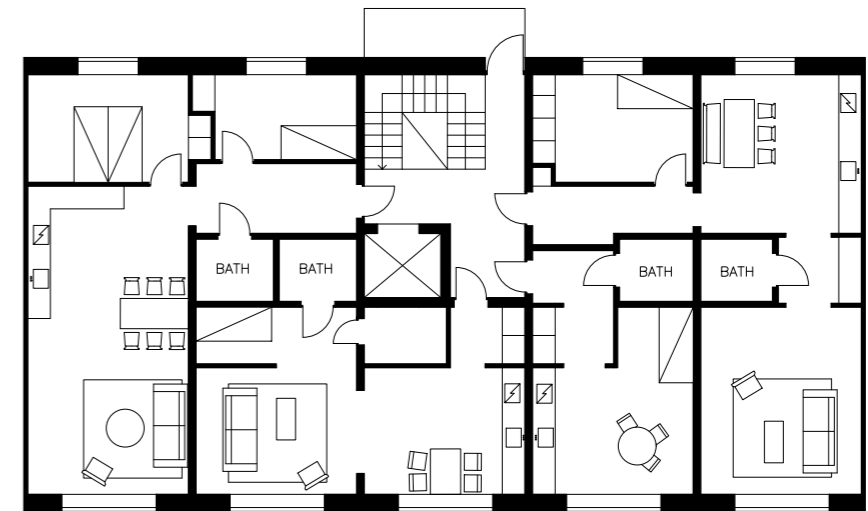

Floor 2-3

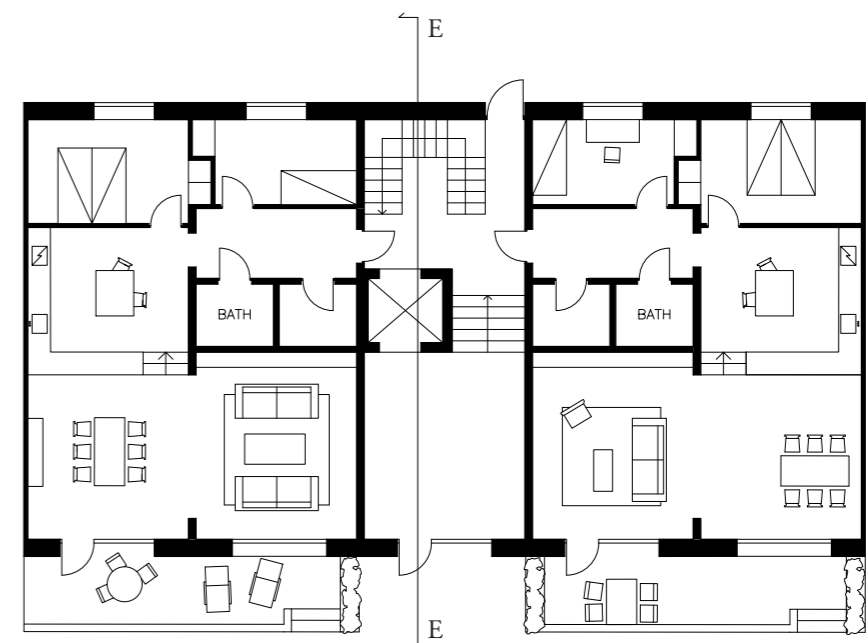

Entrance floor

Townhouse module

drawings, 1:200

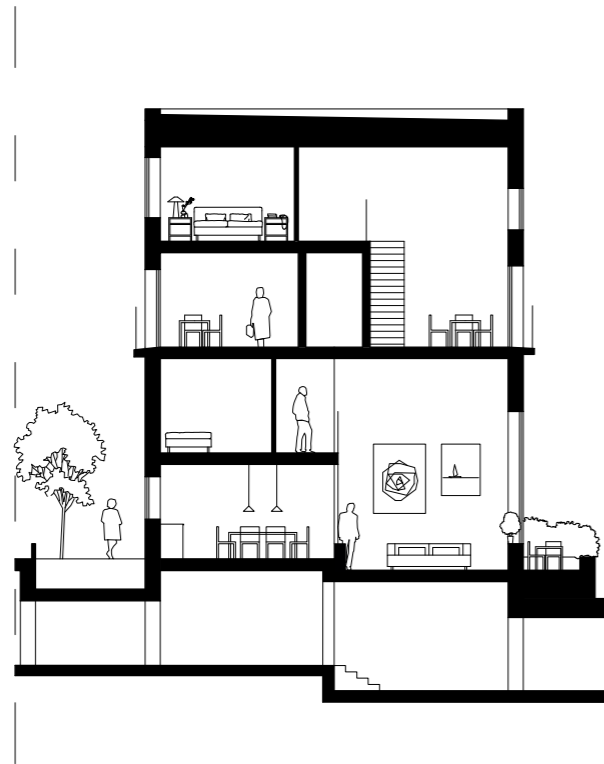

Section C-C

Floor 4

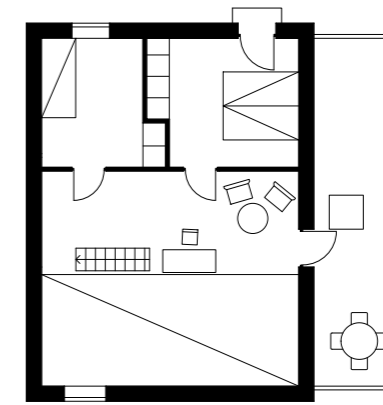

Floor 3

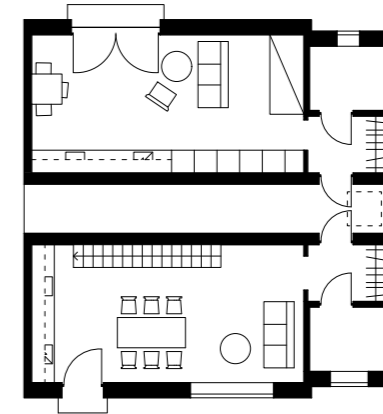

Floor 2

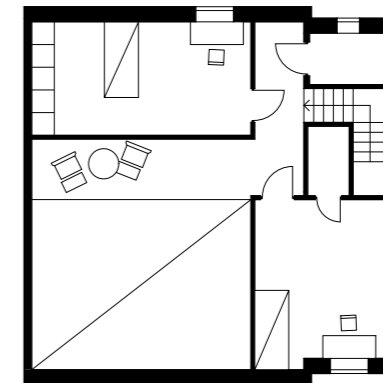

Entrance floor

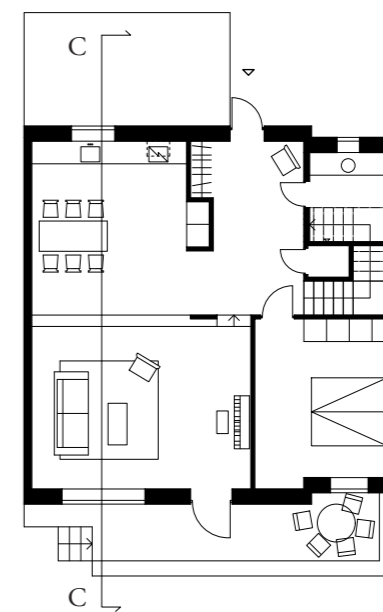

Design project

Floor plans

Block no. 1 - floor plans, 1:800

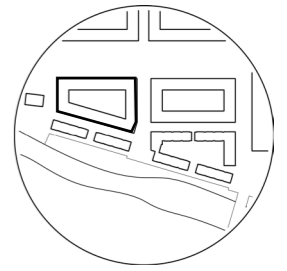

Entrance floor

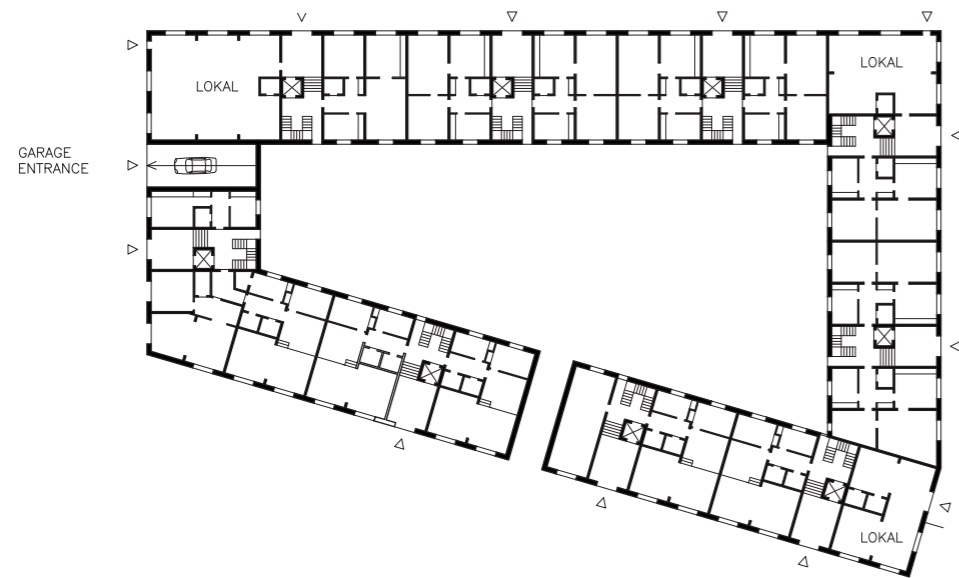

Floor 4-5

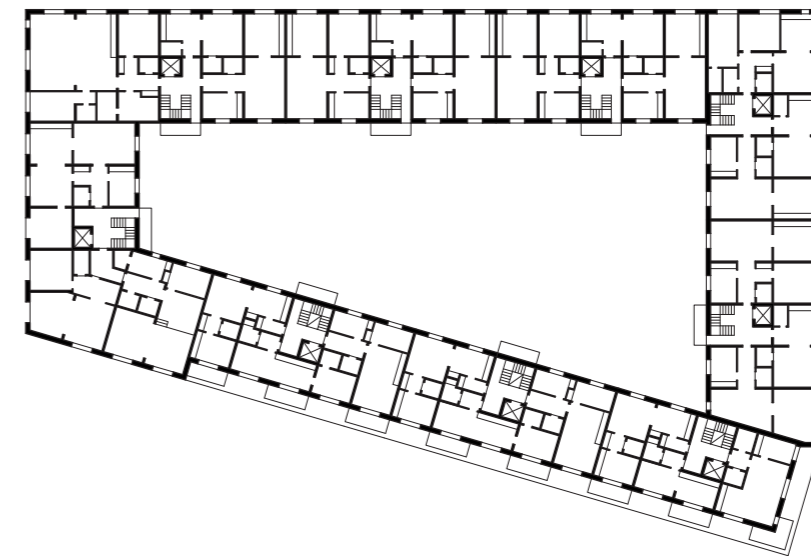

Floor 2-3

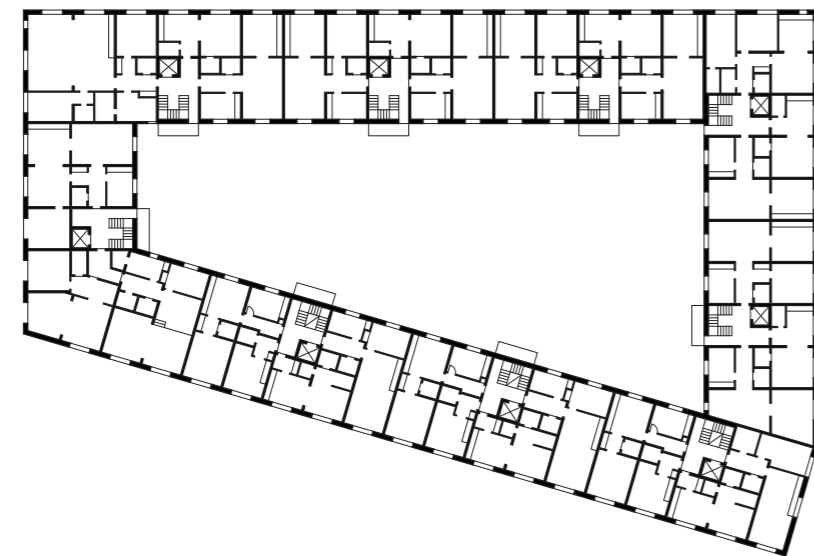

Floor 6

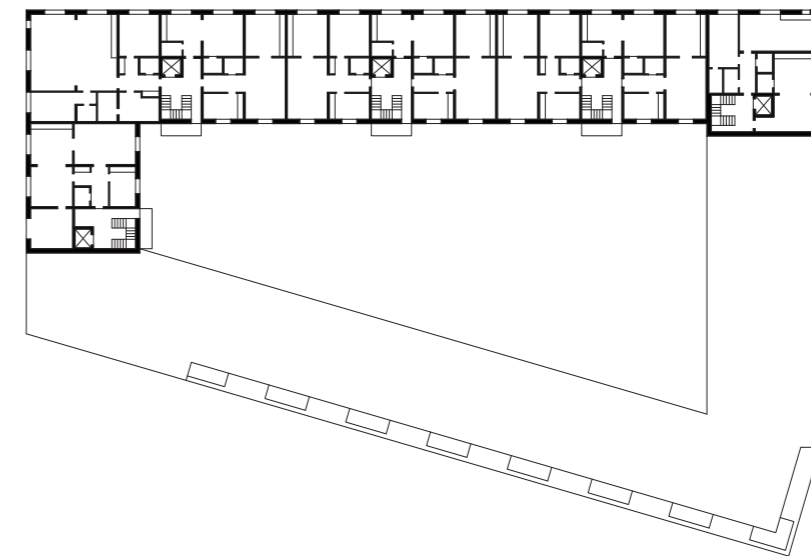

Floor plans

Block no. 2 - floor plans, 1:800

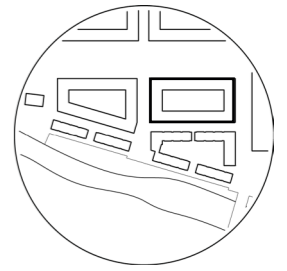

Entrance floor

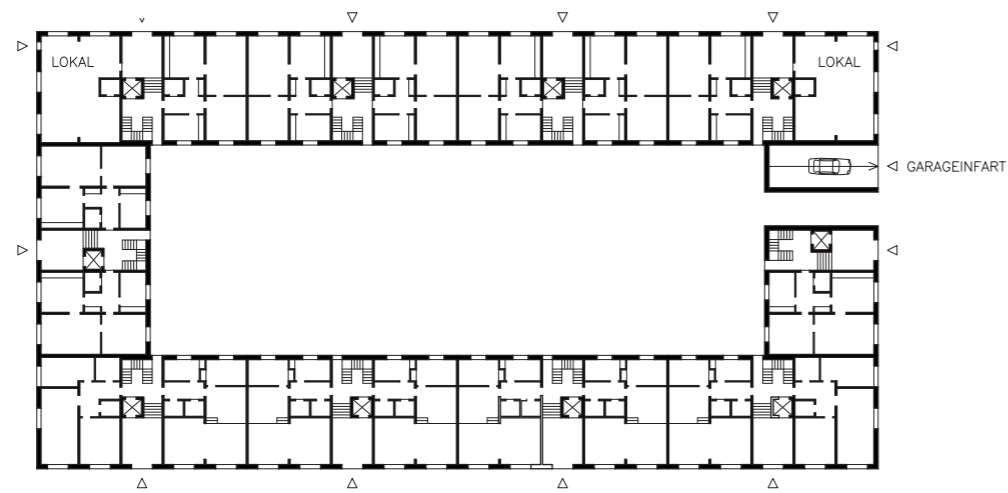

Floor 4-5

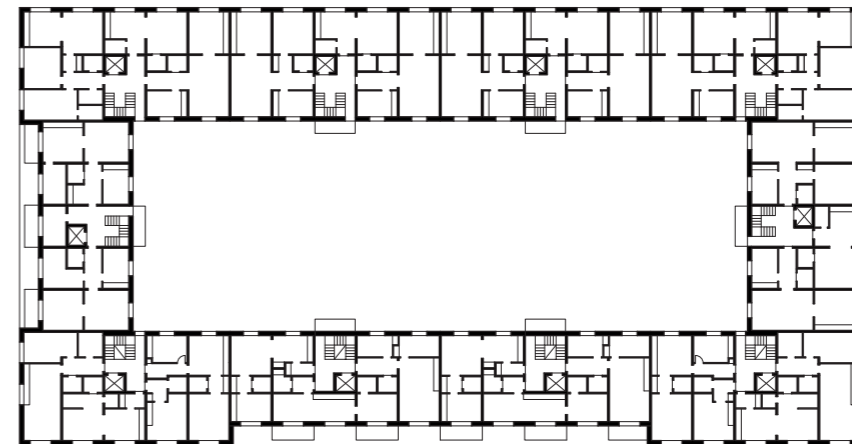

Floor 2-3

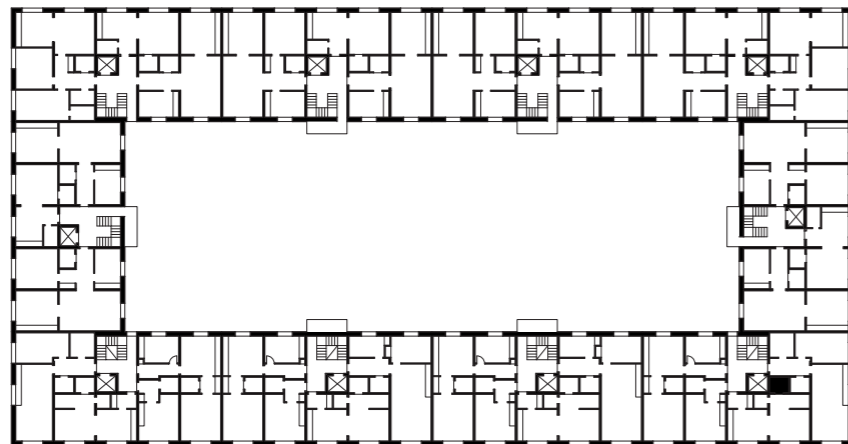

Floor 6

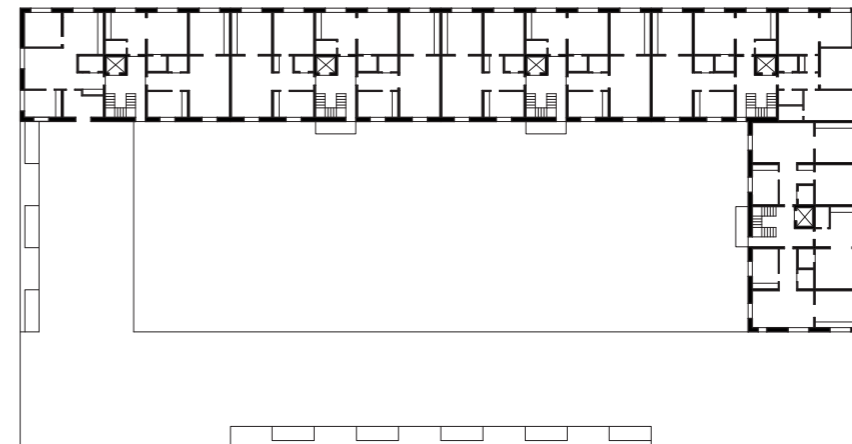

Floor plans

Block no. 3 - floor plans, 1:800

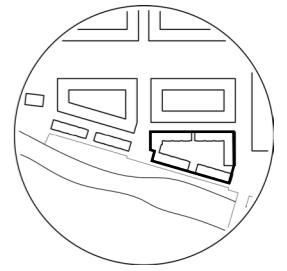

Entrance floor

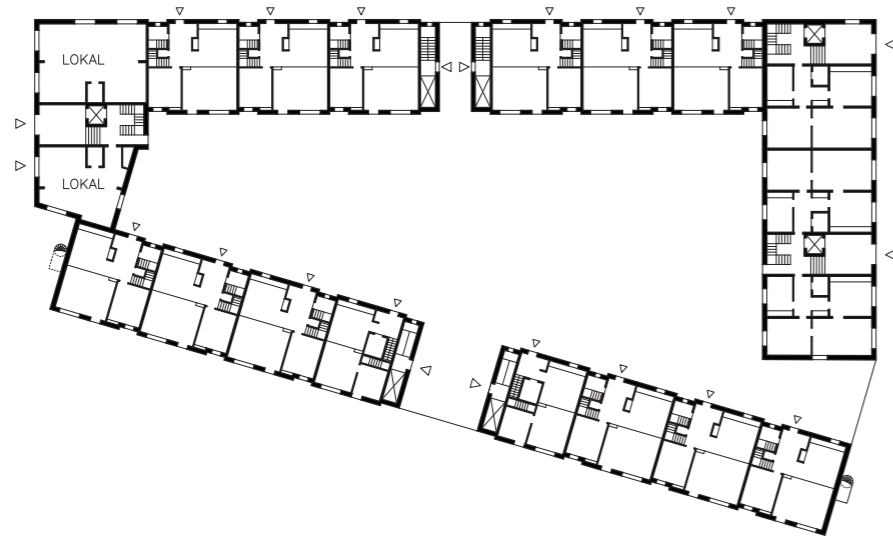

Floor 2

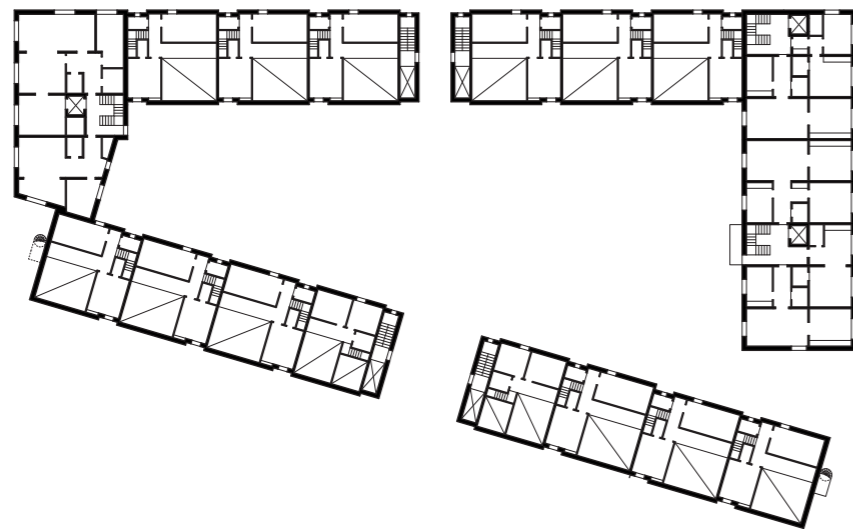

Floor 3

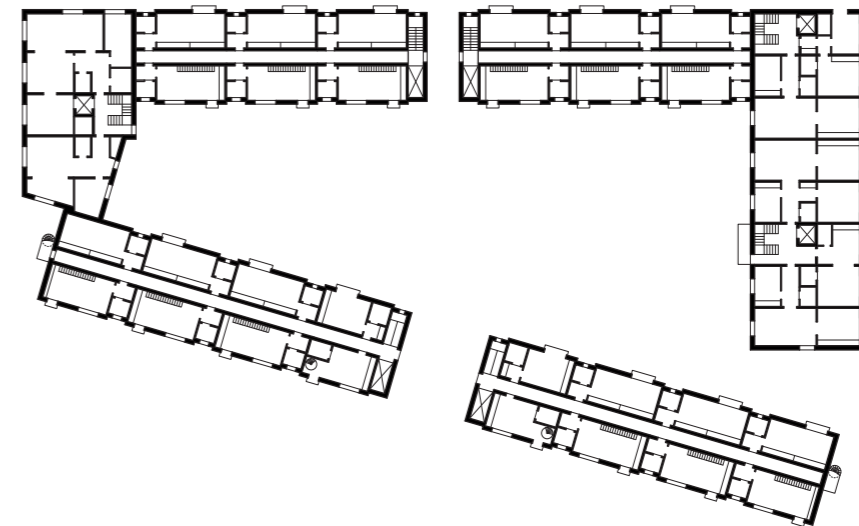

Floor 4

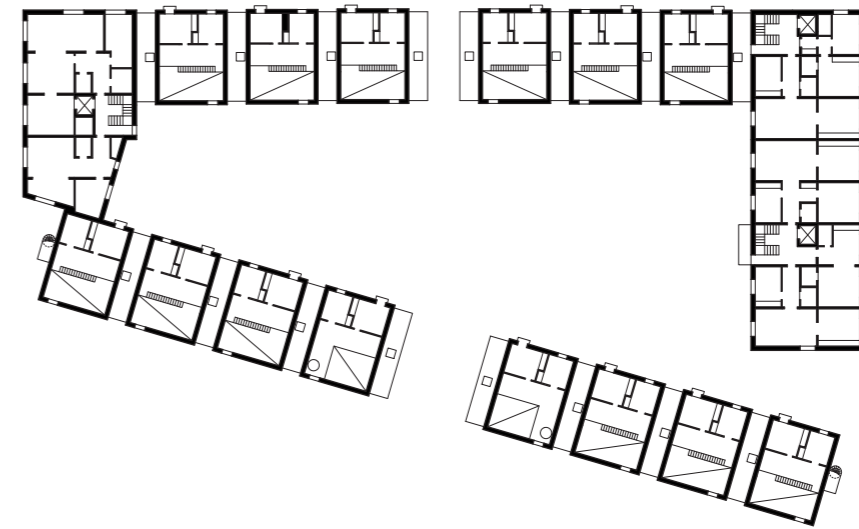

Detail

Townhouse facade

1:50

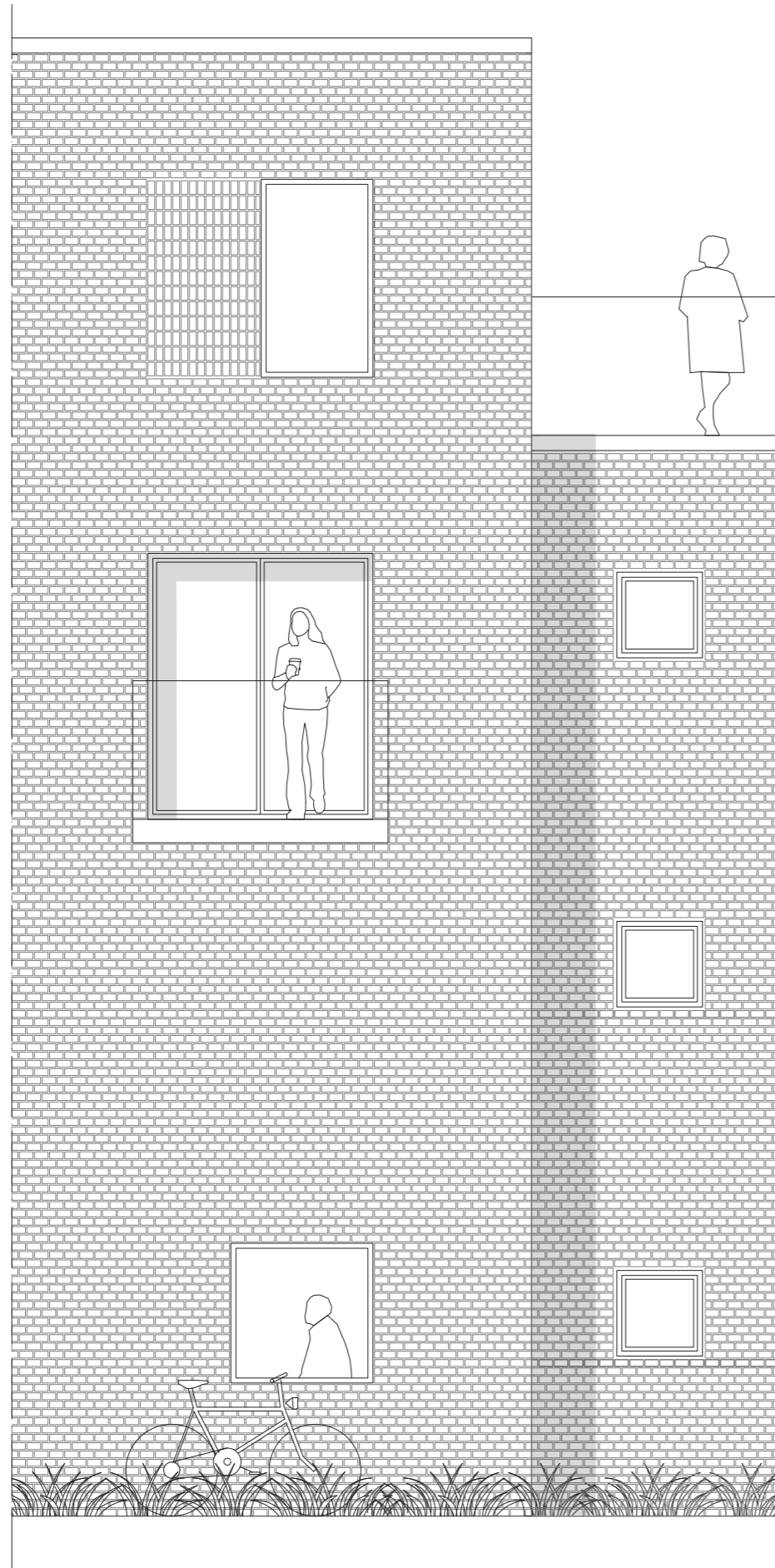

Detail

Townhouse section

1:50

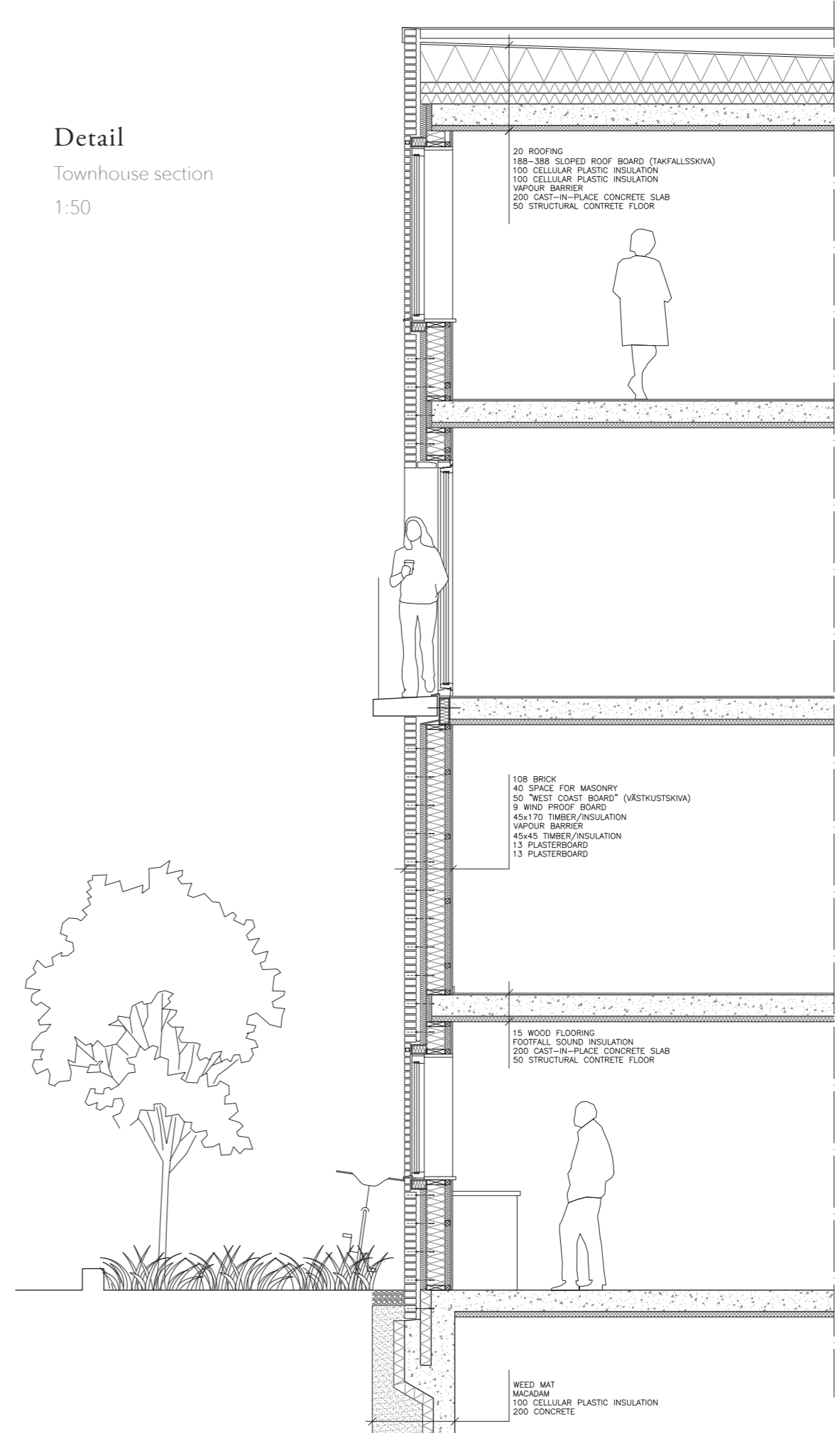

Model investigations

Like shown in the site sections, we identified five different types of situations within the site. Each one of the situations contain a unique interface between street and dwelling. In the project we have gone deeper into the design of these five interfaces. First we will show pictures of physical models representing a short section of each interface, made in the scale 1:20. The models were built approximately 90% into the design process, and served as a tool for evaluating our design. After the models were built and analysed, we went back to the design and made changes in section, plan and elevation, based on our conclusions from the physical model investigation.

The following five pages tell the preconditions and ideas behind each interface, show photographs of the models, and a short summary of our analyses that in some cases led to changes in the design. One conclusion that will show in most analyses of the physical models is the general reflection, that the dwellings were perceived as too exposed.

After the pictures of the model investigations, we show the interfaces in a zoom-in section and plan after the changes have been made.

Model investigations - interface 1

The first interface is located along Artillerigatan. Artillerigatan is the main avenue in the area and it carries a large number of pedestrians, bikers, trams and cars every day. Between the main vehicle traffic and the residential building is an existing row of big trees. Here we have worked with a hard interface, to distinguish the public- or privateness of each side of the interface. The dwellings on the first floor are elevated and the windows are placed rather high, to ensure some privacy for the residents.

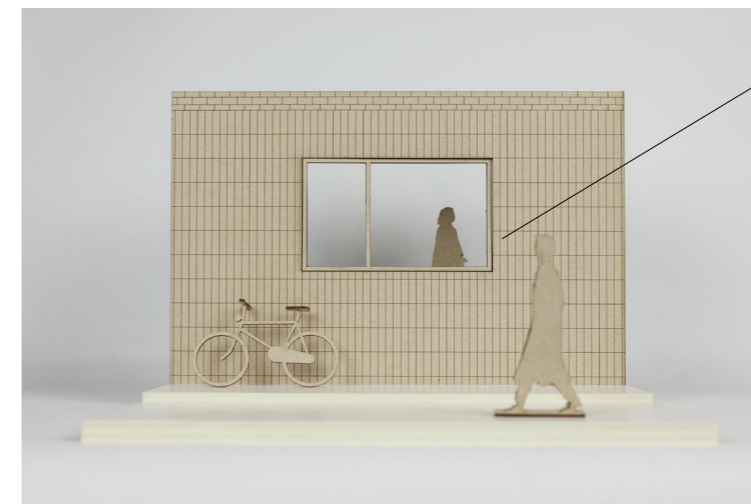
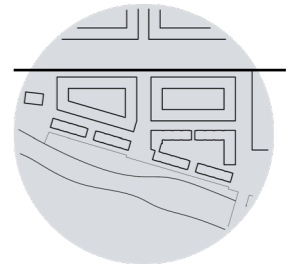

“Wouldn't it be better if the eyes of the man on the street were below the window? With this relation, the woman inside might want to pull down the blinds, or move further into the apartment. We need to work further with the tools Degree of Transparency and Distances and Levels.”

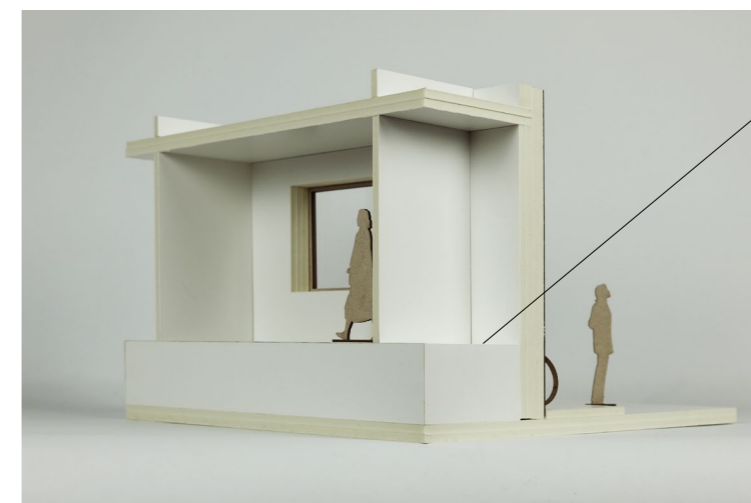

“From this perspective, the elevated floor in the dwelling looks to be at a suitable height (differing from 800-1400mm from street level depending on where you are on the street) The window could benefit from moving up a bit though! The sill is currently at 700mm from the floor.”

Model investigations - interface 2

Interface 2 is found along Banérskatan. It has a much slower vibe than Artillerigatan, but is still an important street in the area, connecting Artillerigatan to Sävån. Banérskatan ends in a small public place, overlooking the river and riverside park. As on Artillerigatan, the first floor dwellings are elevated, however, they have a second entrance linking them directly to the street through a "stoep". The stoep acts as a semi private zone and creates a softer interface, where the residents are given a small opportunity to claim their street and the interface.



"We need to rearrange the floor plan so that this room is not a bedroom, it becomes too exposed like this. If we can also higher the window sill slightly that would also make the indoor situation more relaxed."

"This window/door would definitely benefit from a sill, like the one to the right here. Even if it has the railing from the stoep in front of it, that might not be enough"



"This street looks pleasant, I think these "stoeps" could really work here!"

Model investigations - interface 3

The third and fourth interfaces are located along the two sides of Kullageratan. Interface 3 has a sunny position on the north side of the street, and is part of the apartment block. Kullageratan is mainly a residential street, and the calmest street on the site. Here the first floor dwellings are on a slightly lower level, and end in a terrace-like railless stoep at a height of 450mm. In this interface the dwellings have a close relation to the street. The most private rooms of the dwellings, the bedrooms, are facing the yard.

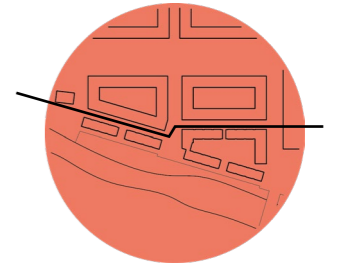

"The relationship between the pedestrian and the resident seems too intimate, she can see way too much of what is going on in the dwelling. Can we give the stoep a clear border of some kind to ensure the territorial clarity?"

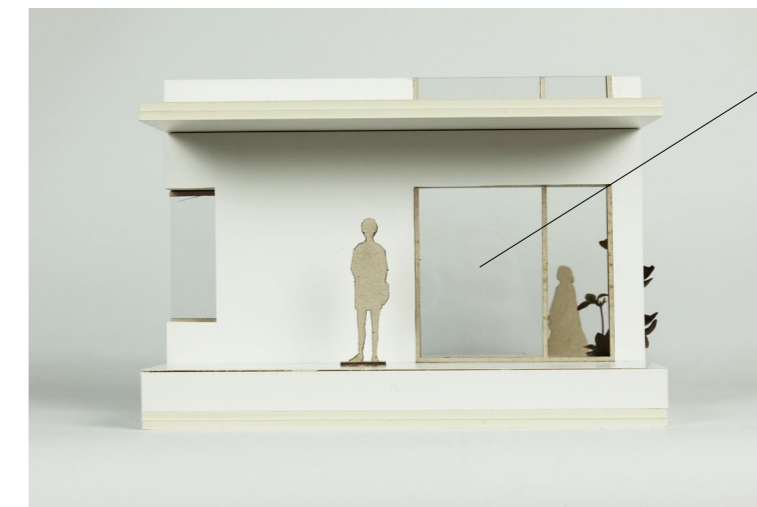

"Making both windows smaller, and especially giving the right one here a higher sill would improve the situation!"

Model investigations - interface 4

In interface 4 the bottom dwelling works as a typical two floor row house. The floor level is on the same level as the street, and the window on the first floor is therefore smaller and higher than in the other interfaces. However, there is a semi private zone "belonging" to the dwelling between the building and the public part of the street.

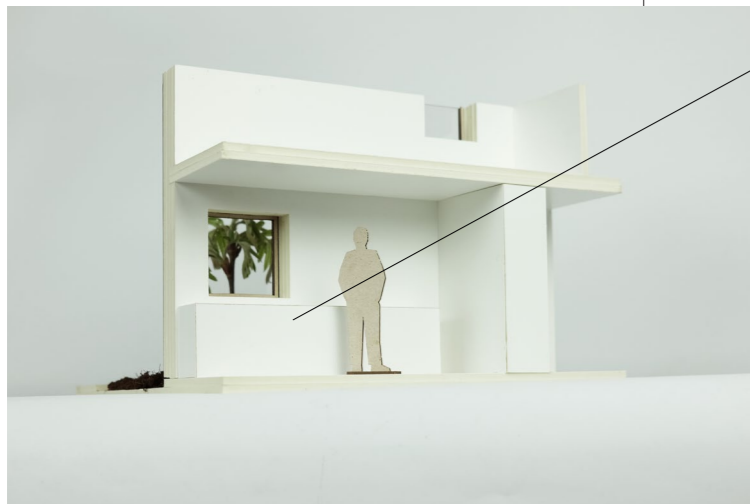
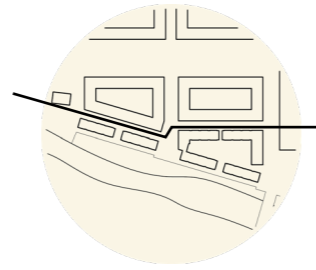

"This interface works rather well! The combination of the smaller window over the kitchen sink and the tree outside really gives a good amount of privacy to the dwelling."

"We are concerned that the garden border is not distinct enough. Residents might start putting up own fences if we keep it like this"



Model investigations - interface 5

The fifth interface is situated between the back side of the townhouses, and the narrow recreational stroll Sävåns Strandgata going along the riverside park. Here the traffic consists of pedestrians only. The bottom dwelling in the townhouse has a small stoep with possibility to grow plants in front of the stroll, and big windows overlooking Sävån. The windows have a sill at the height of 600mm above floor level, and the room is elevated from the stroll with an additional 600mm to create the right level and distance from the people outside.

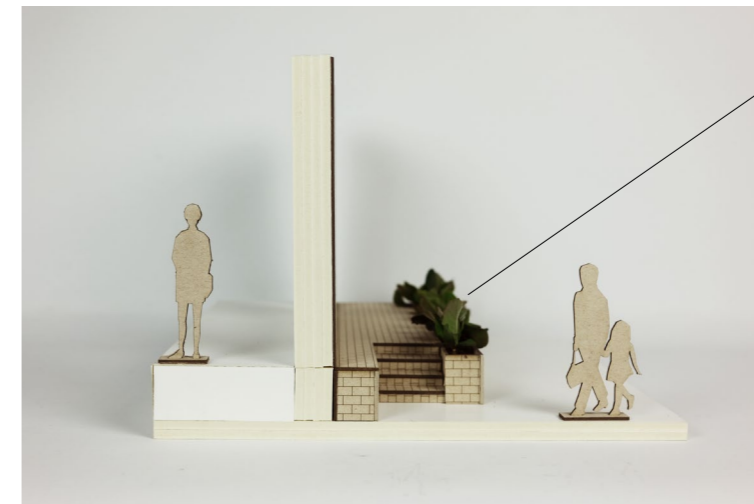
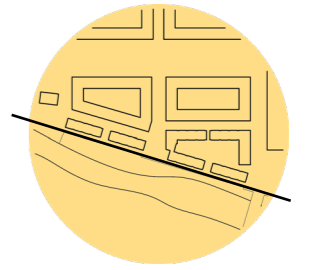

"This built in opportunity to plant something might work out well. It adds value to the stroll, and the residents can choose the height and density of the plants themselves."

"Were the tall windows a too bold choice? Or could it be that the residents are more "generous" with being seen from the stroll as they get this great view in return?"

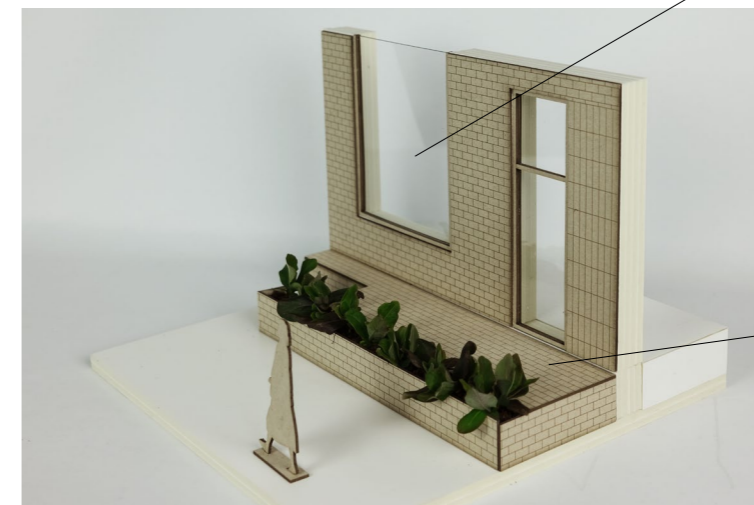

"Is this stoep too narrow to be functional? It would probably benefit from some extra width, let's see if there is space"

Interface 1 – Artillerigatan

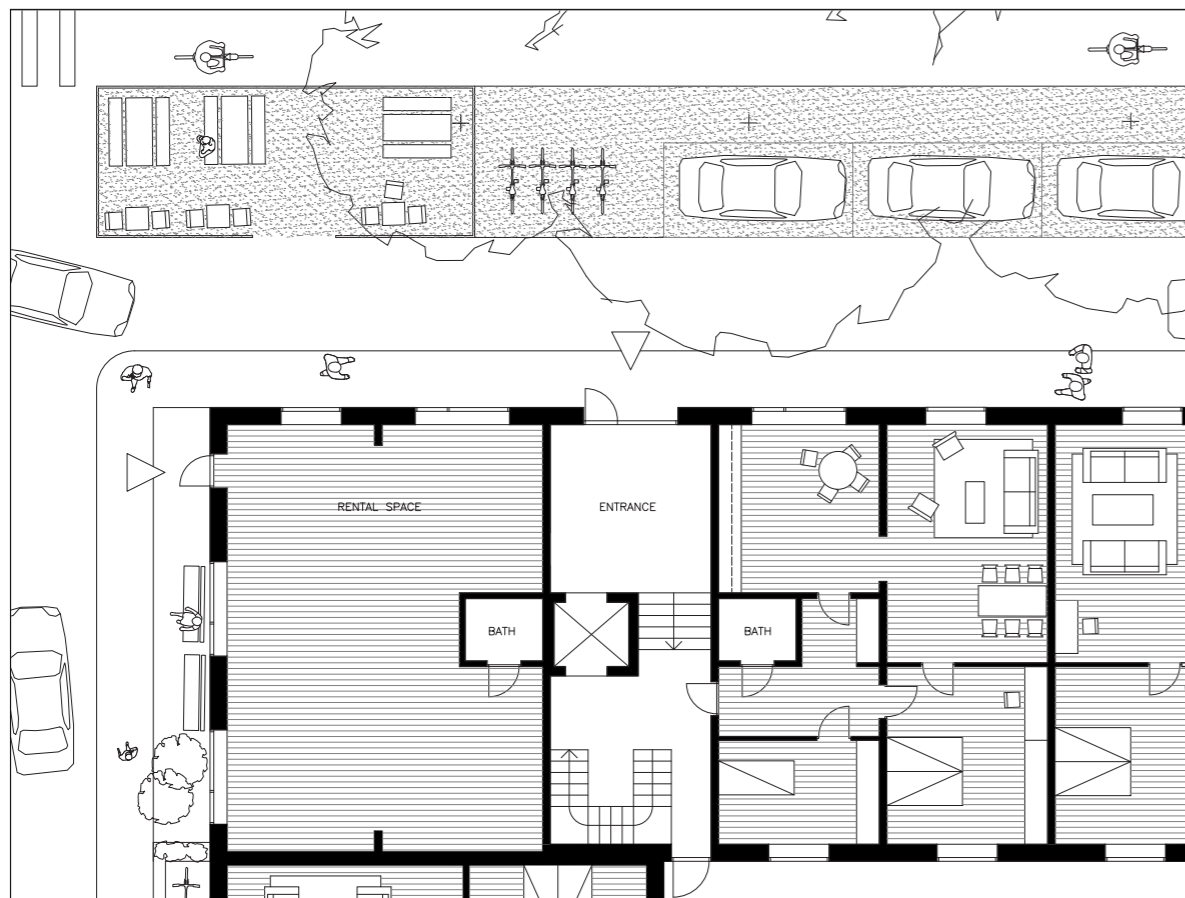

Ground floor with surroundings, 1:200

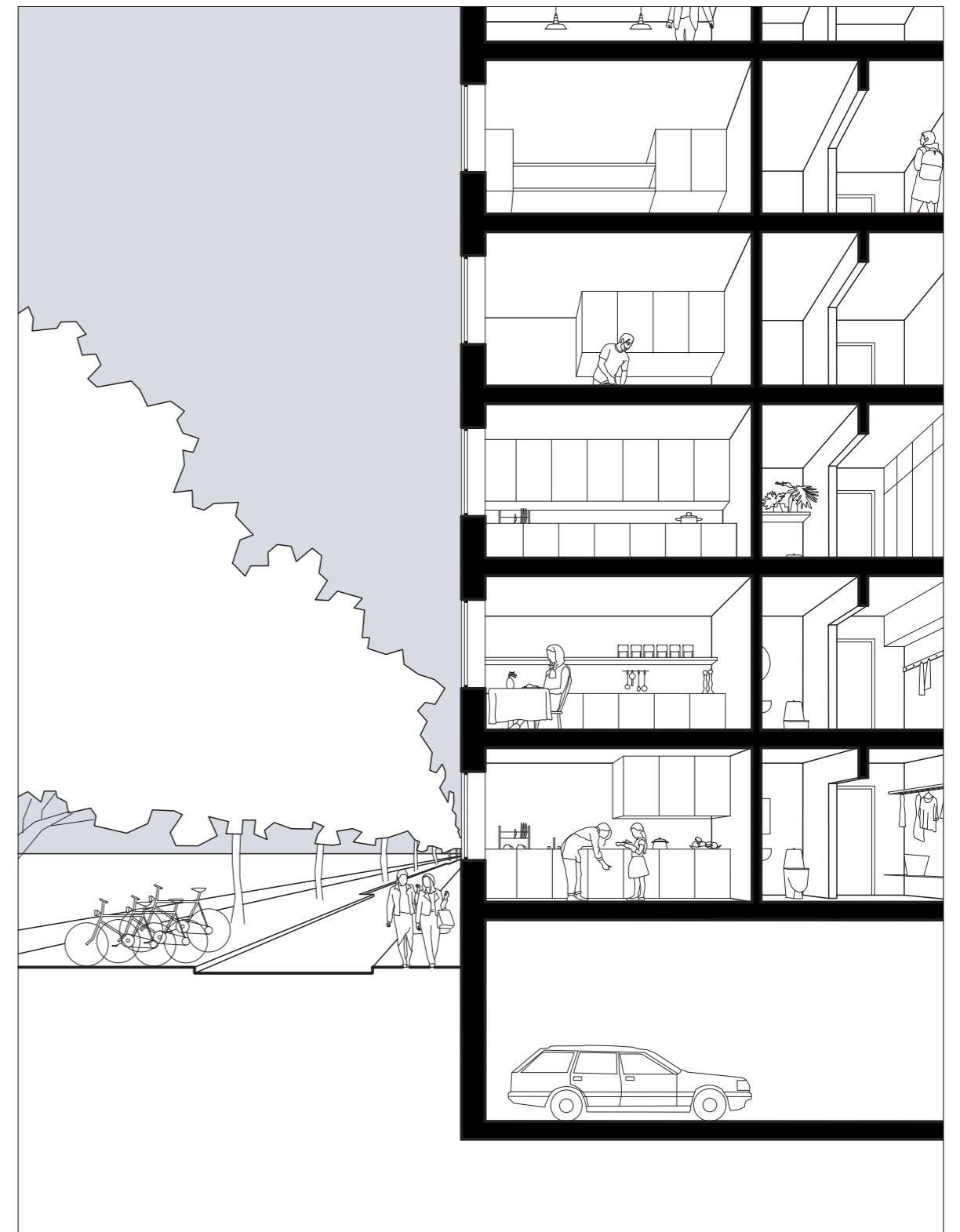
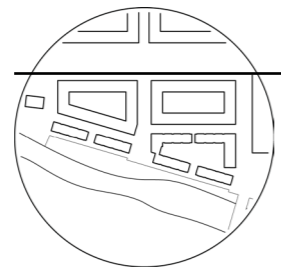

Perspective section, 1:100

Elevation Artillerigatan, 1:400

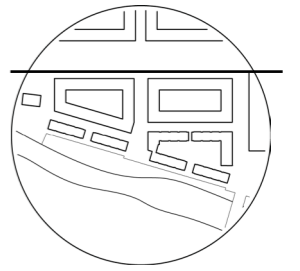

View over Artillerigatan

In the late afternoons the sun reaches the facade of Artillerigatan. The warm pink light brings people to the outdoor settings under the leafy avenue trees on warm summer days. The row of trees separates the busy street outside from the calm one way street along the dwellings. It also separates the loud and lively life of the restaurants and evening promenades under the trees from the private dwellings above the treetops. If the residents along the street open their windows they can hear the sound of the rattling and giggling trams passing by and be reminded of the fact that they live in Gothenburg.

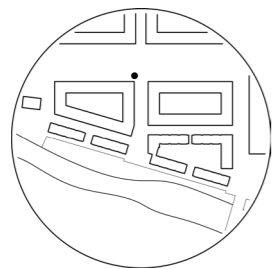

Interface 2 – Banérskatan



Ground floor with surroundings, 1:200

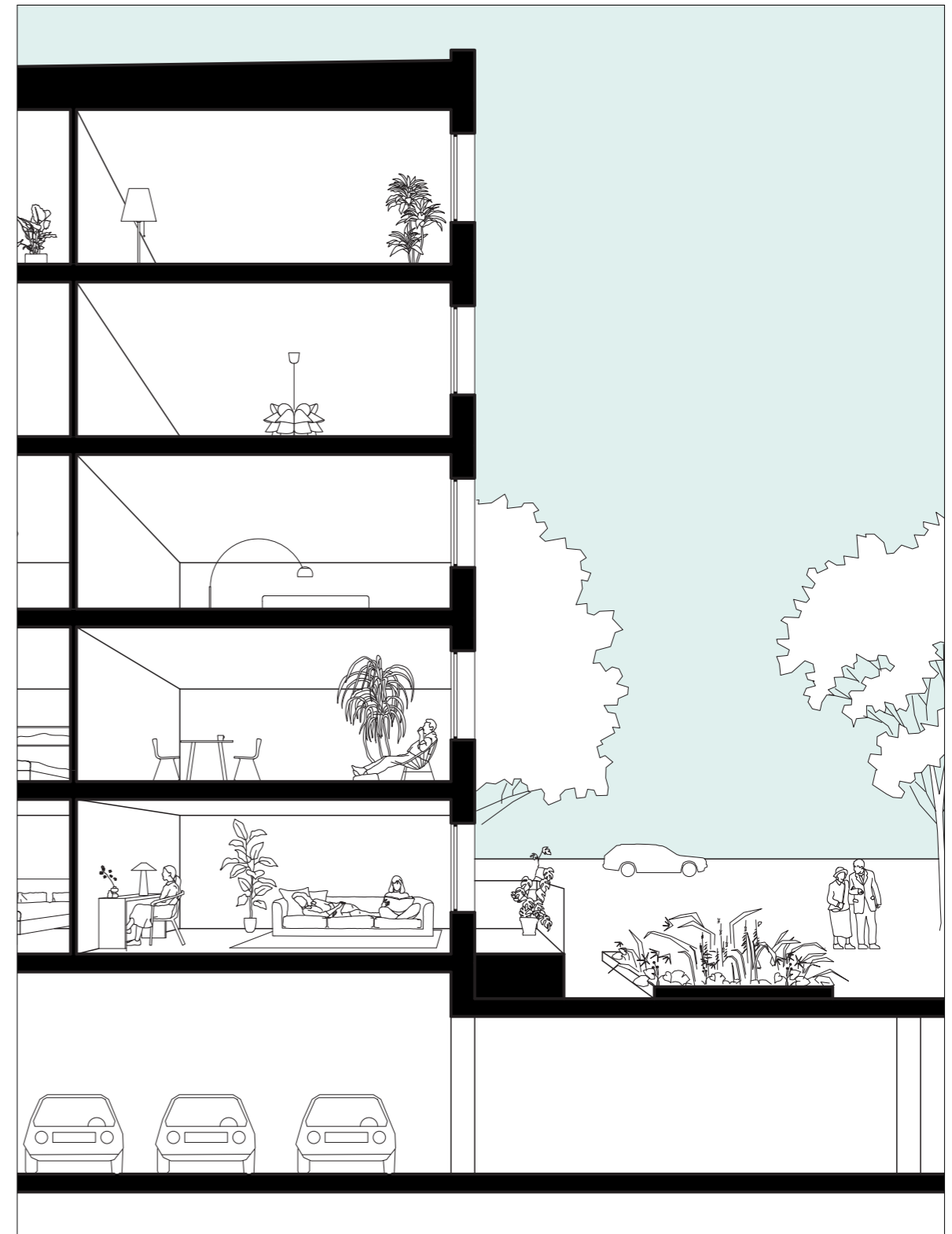
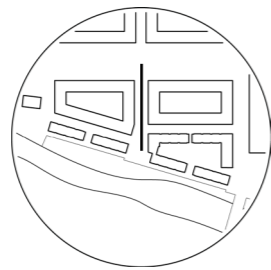

Perspective section, 1:100

Elevations Banérsgatan, 1:400

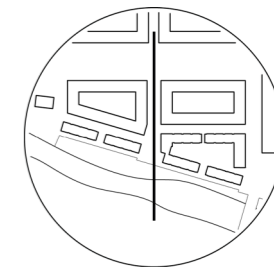

View towards Banérsgtatan

When the sun is out, the open place at the end of Banérsgtatan becomes filled with people. It seems like the wind never blows there, between the buildings. The three trees in the center collect all streets of the residential area and constitute a backdrop for the streets that will change with the seasons. A few steps down a big open space spreads out with a view over the water of Sävån and of the treetops at the edge of the river.

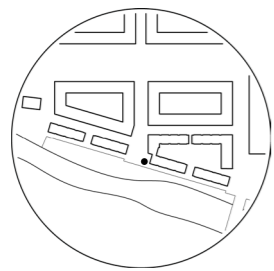

Interface 3 – Kullagergatan (north side)

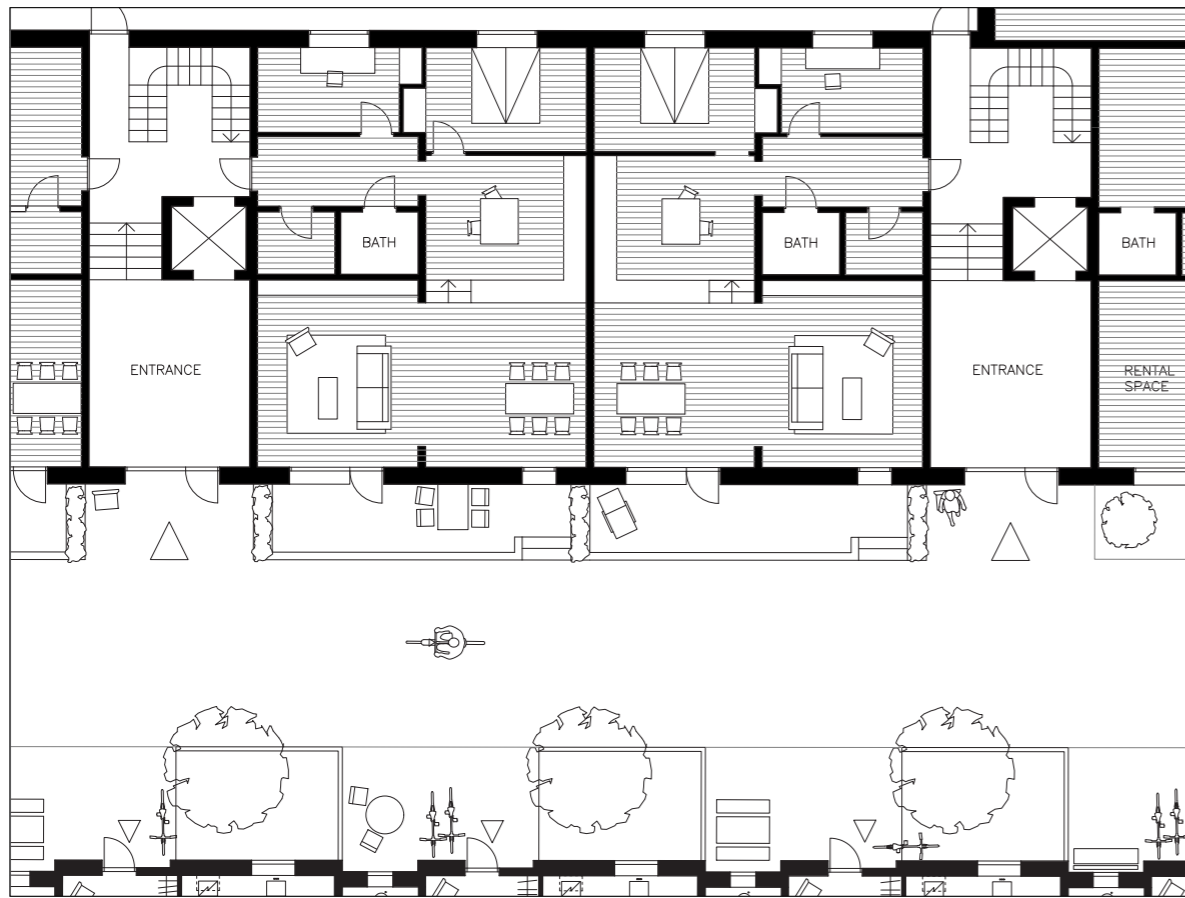

Ground floor with surroundings, 1:200

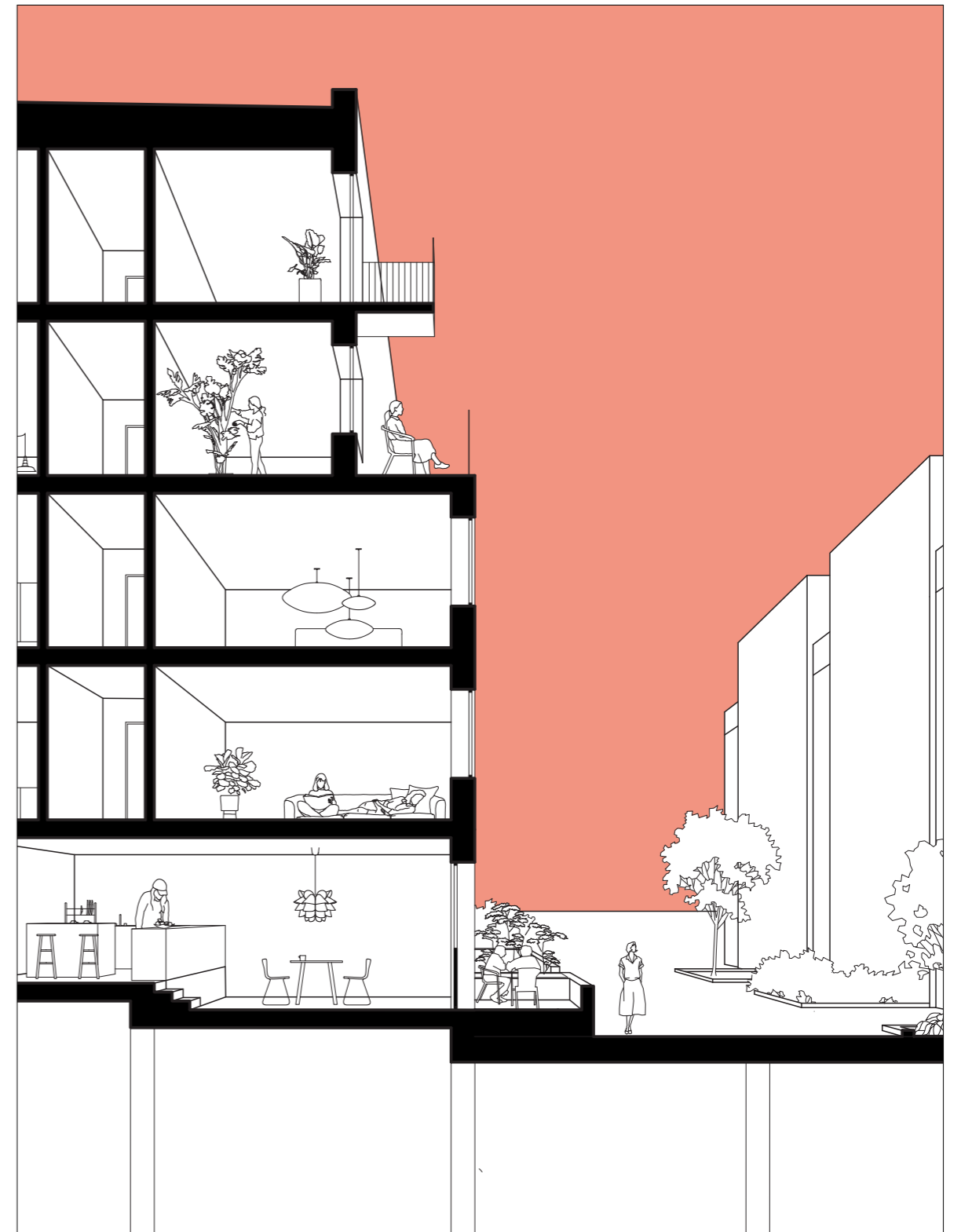
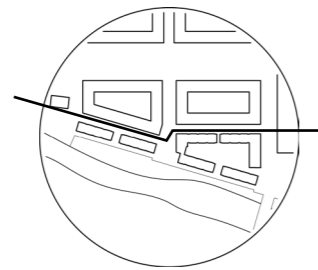

Perspective section, 1:100

North Elevation Kullagergatan 1:400

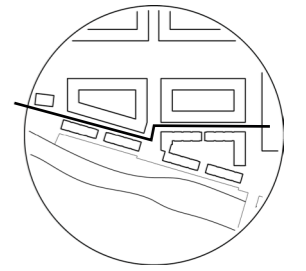

Banérsgatan

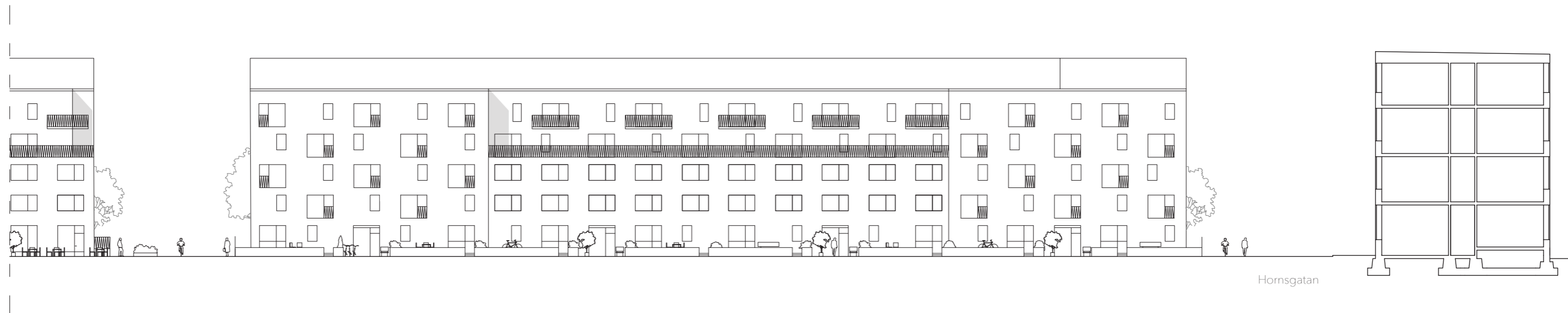

Hornsgatan

Street view Kullagergatan

Despite its central location in Gamlestaden the narrow street of Kullagergatan has the character of a local residential street. The street is edged by the private life of residents eating, playing, chatting or gardening. A part of the long red brick facade of the industrial area of SKF constitutes the backdrop of the street, connecting the residential area to the history of Gamlestaden.

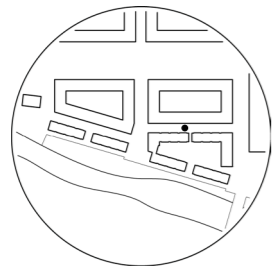

Interface 4 – Kullagergatan (south side)

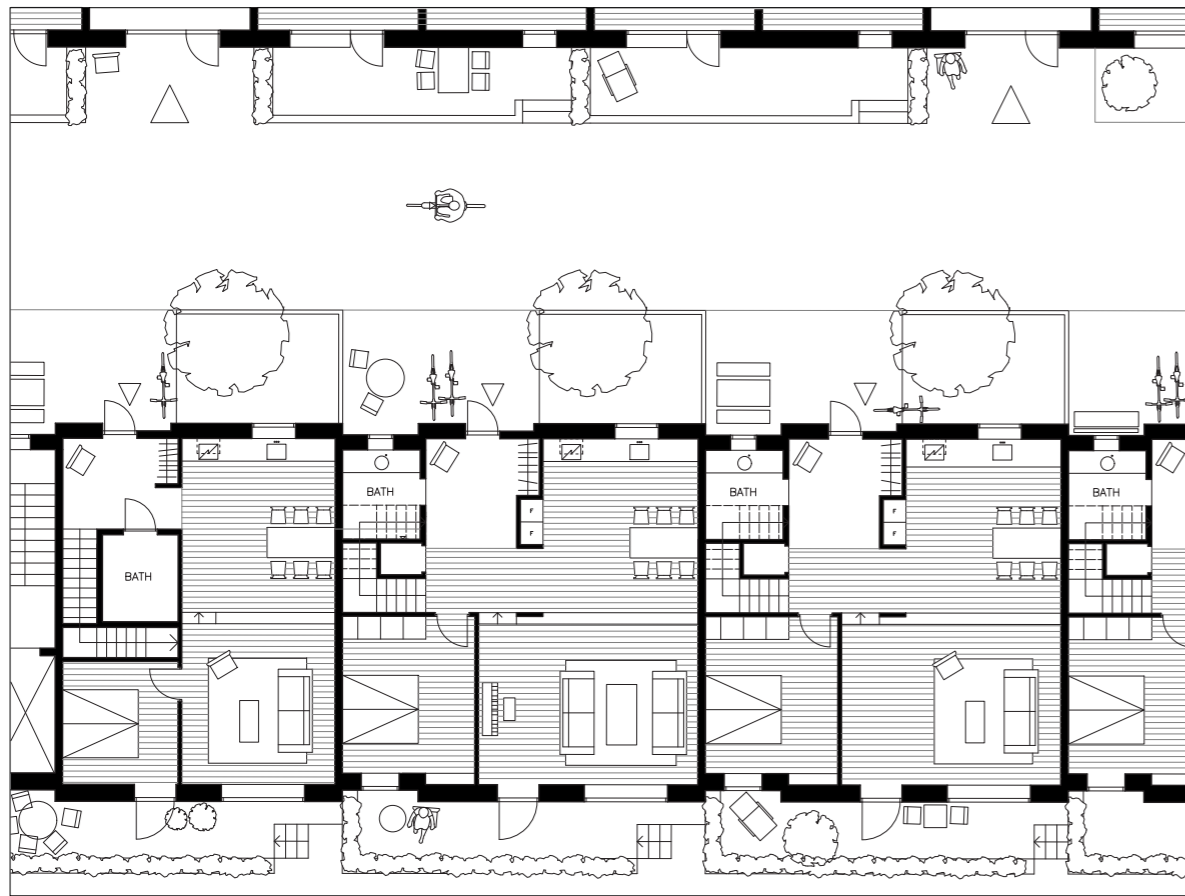

Ground floor with surroundings, 1:200

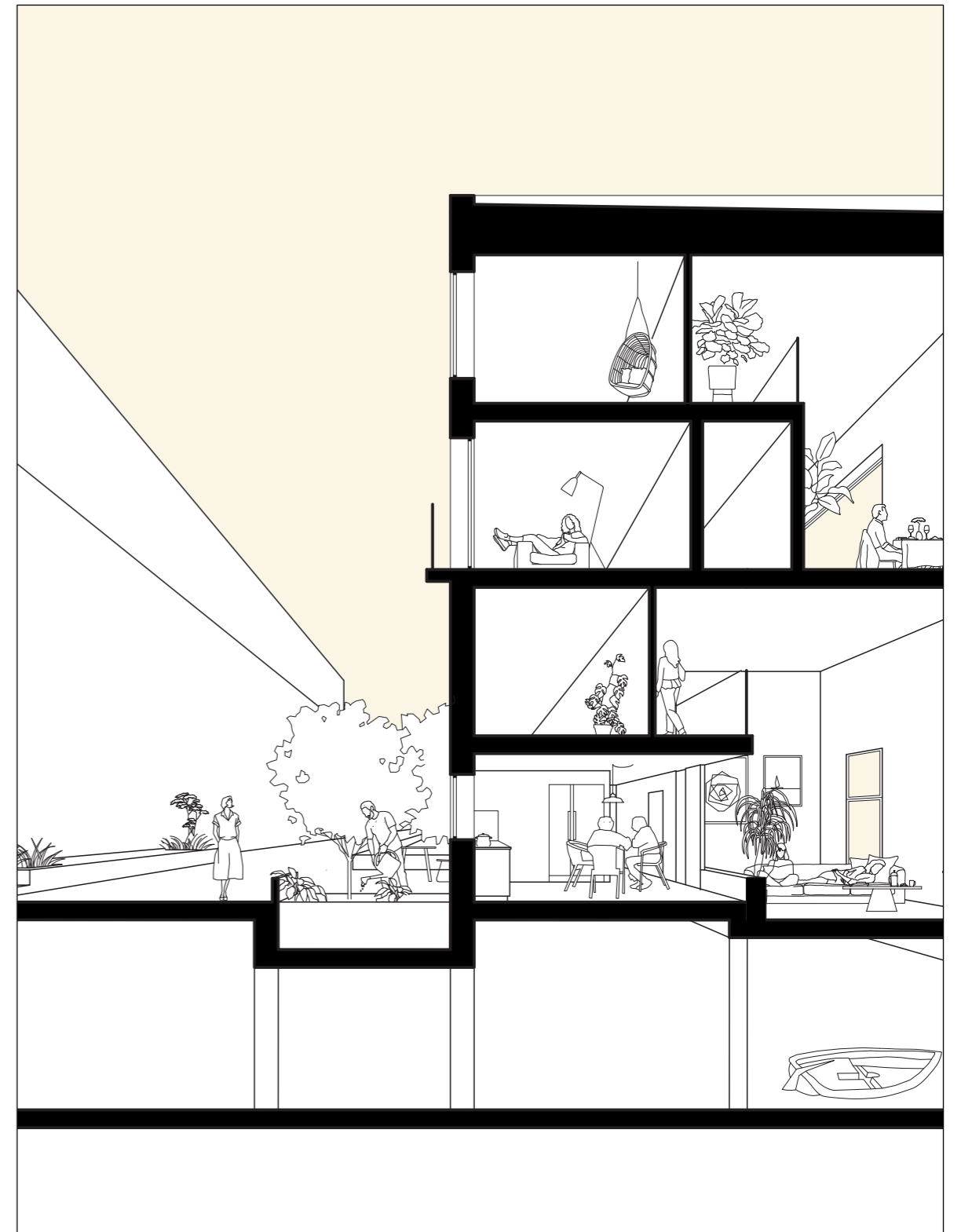
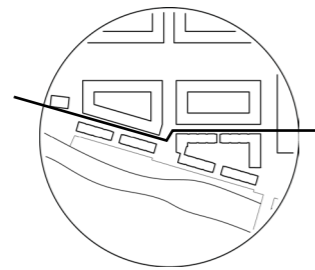

Perspective section, 1:100

South Elevation Kullagergatan 1:400

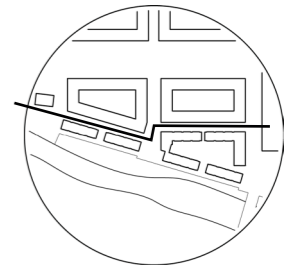

View from Sävån

The wall separates the residential area from the recreational stroll, the industrial character of Gamlestaden from the leafy greenery of Sävån, the pulse from the pause. This is one of the few places in Gamlestaden where its residents can touch the water of the river that cuts through the whole area. Sitting in the sun at the bench along the wall you can hear the sound of people chatting under the trees and children playing with the weather. When the first snow falls the slope in the park becomes filled with colorful sledges and on the first spring days, the smell of tar from newly painted boats in the opened garages of the wall fills the air.

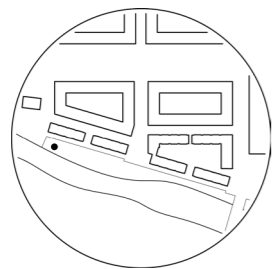

Interface 5 – Sävåns Strandgata

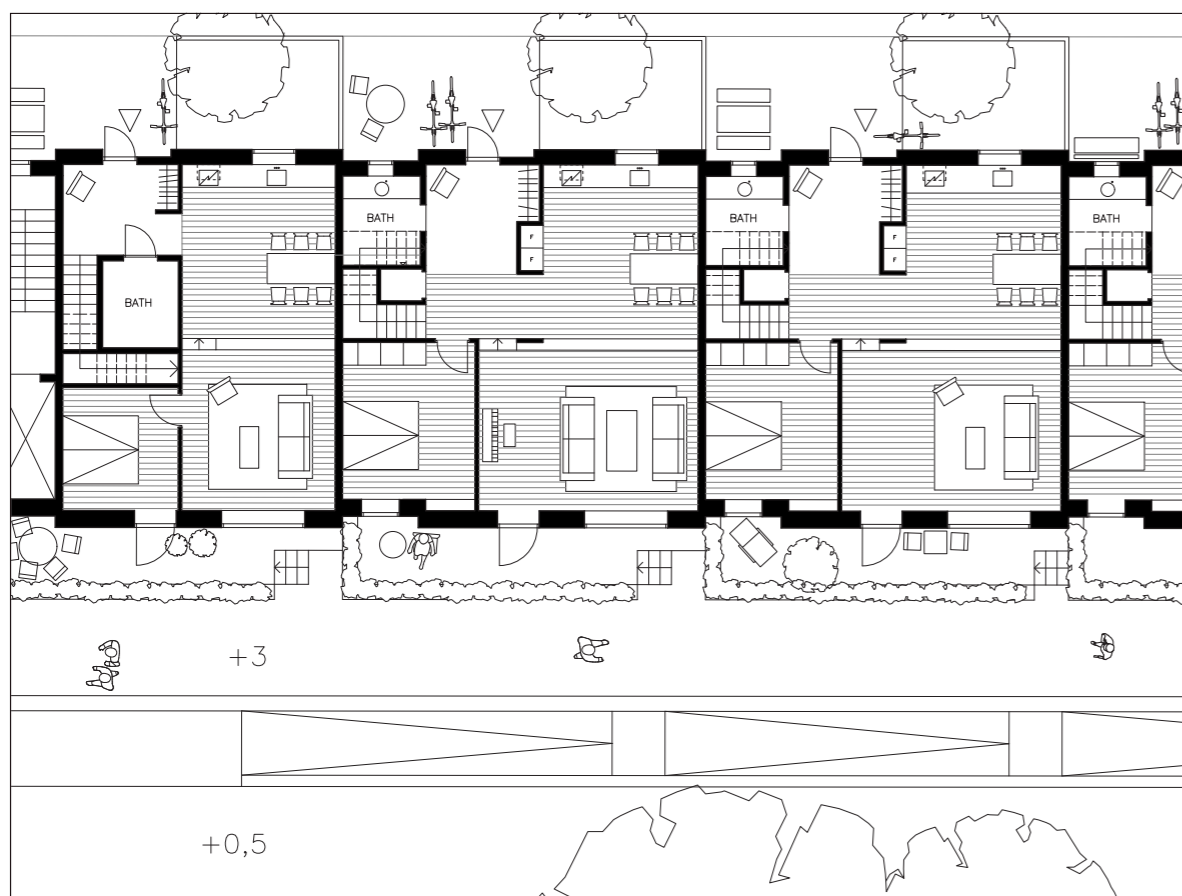

Ground floor with surroundings, 1:200

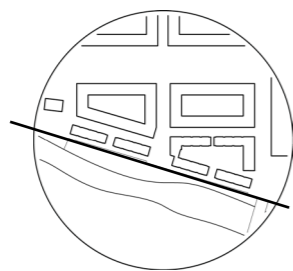

Perspective section, 1:100

Elevation Säveån, 1:400

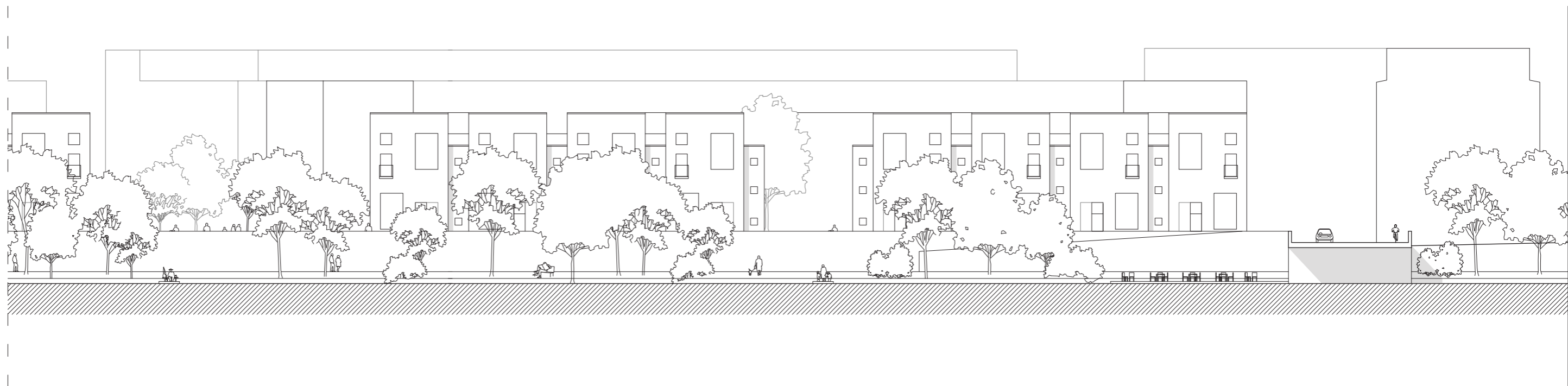
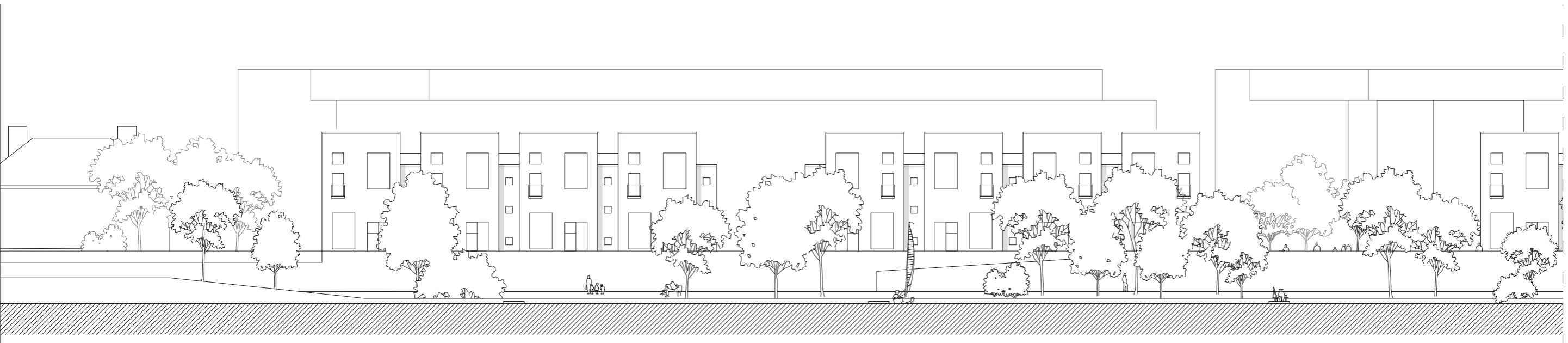
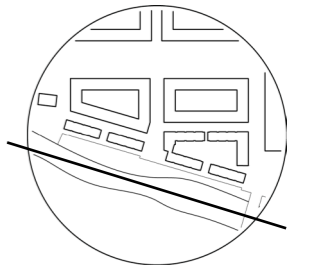

5. DESIGN TOOLBOX

Through studying theoretical work and built references, together with the process of designing, we have noticed some key factors, that when used in the right manner, seem to increase the usage and thereby the quality of the interfaces between private and public space. Make a place beautiful and appreciated. On the other hand, if they are not as carefully considered, they can have the opposite effect, and leave the space empty, unclear and forgotten. In the following chapter, we will present these factors as *design tools*. But as everything is not in the hands of the architect, a few selected *preconditions* will also be mentioned. Things that cannot be affected, and therefore need to be considered, and well balanced together with the tool.

Preconditions

First, we will look at the predetermined factors, the preconditions. What *type of street* the interface is edging has a big influence on if and how it is used. The dimensions, connections and locations of the street affects how public or private it is perceived. The traffic of the street also plays a big part where small scale streets in residential areas, with just a few slow driving cars are more likely to be used by the residents than the opposite. However, urban streets defined by high buildings and much traffic can be perceived as safer than a one-storey residential area with fewer "eyes on the road" (Jacobs, 1961).

Different *cultures* in the world have different norms for how the urban spaces and streets outside the dwelling are used. What is the norm in one part of the world might be considered strange in other parts. For the architect this means that if a certain design encourages usage of the street space in one culture it won't necessarily have the same effect in another culture. In many cases the culture is a consequence of the *climate* in the region. It goes without saying that outdoor spaces become more used in warmer climates, or on days when exterior conditions are more favourable. Architectural elements can provide spaces with more favourable micro-climate through for protecting from unpleasant wind and rain.

Design tools

Following, seven design tools that all impact on how the spatial interface between private and public territories is used and perceived will be presented and explained. The tools can be implemented in different ways depending on the preconditions of the site, and can be seen as parameters that combined in different ways also have an effect on each other.

The first five tools deal with how the place just outside the dwelling can encourage usage and social encounters by the residents and passers by. It goes without saying that there needs to be a place to use, even though this is far from always the outcome in the design of a residential area. A *semi-private space* in-between the private home and the public street offers the residents a place to stay outside the home and will thereby increase the time spent outdoors by the residents. Certain size of a front yard is for example proven to promote interaction (Gehl 2006) The spaces might be a front yard, a balcony or a dutch stoep. The space is proven to be used more if it has many *entrances* that give easy access from the residents' home to the space. Furthermore the space needs *territorial clarity* for what is public space and what is private space. A clear distinction and coding between different territories makes the resident or the visitor confident in using the space. If the territoriality is unclear the space risks to be either unused or cause conflicts over who has the right to use it.

The *architectural quality* of the space is another character that affects the usage, a well designed urban space tends to attract people. Though it is subjective what is good architecture and not, aesthetic values, beautiful materials, and well considered details expresses an environment that is taken care of and that gives reason to continue to take care of it. Lastly, the opportunities for *activities* can increase the use of a space. The design of a space can encourage different behaviors, a bench, a front stoep or an intriguing shape

can call for sitting down, gardening or playing.

The two remaining tools deal with the relationship and interaction between the resident in the private dwelling and the passer by on the street. The placement and the amount of glass in the facade affects the *degree of transparency* between what happens in the private space and what happens in the public space. Too much transparency results in dwellings with too much insight, and there's a risk that the residents will cover the windows with curtains and blinds. On the other hand, too small windows will result in a weak relationship between the private and the public. A weak relationship has a bad influence on both the character of the street, that becomes hidden and unsafe, and the dwelling, that becomes isolated from the world outside.

To decrease the insight and reach a desired relationship between the street and the dwelling *distances and levels* can be used. A front yard or a stoep gives a distance between the street and the dwelling. Distance can also be achieved by elevating the dwelling to a higher level than the street and putting the windows higher up on the walls to break the sightline from the passer by on the street to the residents. Another way to disturb the sightline and reduce the transparency is to add greenery and trees in front of the house or mullions in the window. This relationship needs to be considered with fine balance and precision. The architect's role here is to be the defender of both the street's and the home's interests. His/her task when designing the interface is to give the most possible value to both the private and the public sphere.

7

TOOLS

...to consider when
designing urban areas
and buildings

Semi private space

Small front yards in between the dwelling and street will increase the time spent outdoors and the activity on the street

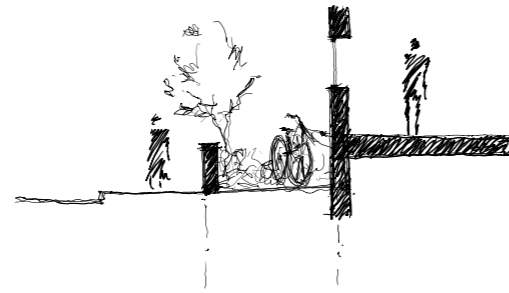

Architectural quality

Well designed buildings and urban spaces with aesthetic qualities, beautiful materials and well considered details will attract people and give reason to care for the environment.

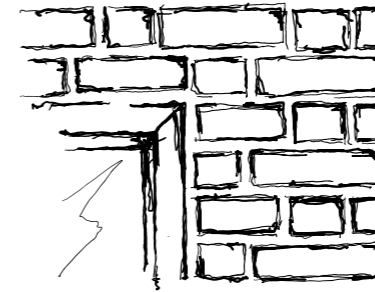

Activity

Opportunities for stationary activities will attract people and make them stay in the urban space.

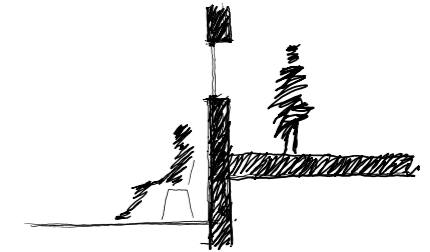

Entrances

Easy access out will make the residents use the outdoor space next to their home more often.

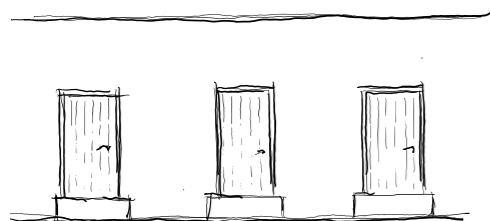

Territorial clarity

A clear demarcation between what is public space and what is private space is necessary for confident use of both territories.



Degree of transparency

Placements and amount of glass in a facade will affect the usage of the private dwelling and the perception of the street.

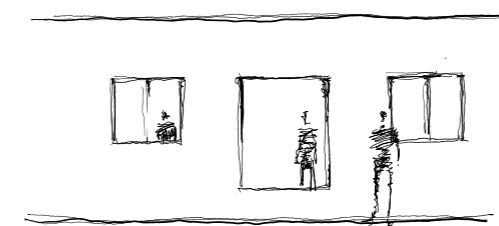

Distances and levels

Distances and elevations can be used to create a desired relation between street and dwelling.

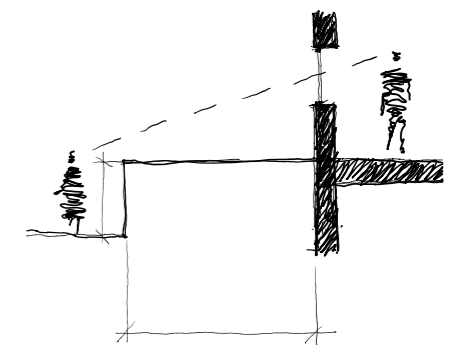

6. CONCLUSION

This master's thesis is an investigation of the relation and interaction between private dwellings and the public streets outside, both in its theoretical part and in the design project. The spatial interface between the two domains, private and public, provided a concrete situation of where we could study how different materials, details, dimension and elements in the interface affects the relation and the usage of the dwelling on the street. Our findings were concluded in seven design tools. Though, we would argue that the result of this master's thesis is both the design toolbox and the design project. Reflecting upon the process, we cannot distinguish which one of them is the hen and which is the egg. Already in the first sketches of the design project we had, from early literature studies, some of the tools in mind, affecting the design. The tools have then been developed, changed and refined as we have encountered the spatial interfaces in the design process. We view our work as a small contribution to the discussion of this specific area of design. It does not cover close to all aspects, and even the "final" version of the design project in Gamlestaden is by no means final.

Out of the result we can draw three conclusions about the main findings, the method and the subject for the thesis:

The seven tools and the design project, both represent design on different scales. A well functioning interface between private and public is designed in both the small scale regarding details; a building scale where the amount and position of the entrances are decided; a property scale where it decides what land should be street, sidewalk, building or in-between space; and a city planning scale where the street network that affects the flow of people is created. For example, we have noticed both how a few centimeters in difference in the position of the windows above the street can be crucial for if the blinds most often are up or down, and that different flows of people on a street affects how public it is perceived. We thought that the big site in Gamlestaden

would provide a good platform where we were in control of the different scales and could try out many different ways of dealing with interfaces. However, we see that the workload of such a big site was bigger than what we estimated and that it would have been favourable for the outcome with a smaller design task, perhaps only one building. It would have given opportunity to reach further with the architectural design and quality of the "final proposal".

The method of working parallel with a design project and the theory behind the particular design challenge is a classical way of working in architecture. The challenge here is often to connect the theory with the design. The construction of the design tools helped us bridge the gap between the two research methods, concluding the theory in concrete and spatial elements and factors that were useful on the drawing table. The design toolbox also provided an argument for a certain design, helping us focus on the spatial interfaces, and what actually had an impact on the perception and usage of them.

In this thesis we argue for design that encourages use of the public space outside the dwelling and the streets. We believe that "life between buildings", as Jan Gehl nicely describes it, is important to make the residents of an area appreciate their home. Furthermore, this thesis argues for how the design of the interface between residential buildings and streets will affect the perception and usage of the two. All buildings meet the street somewhere, which means all buildings have an interface that can be designed in different ways. Our findings claim that, as the designer of a residential building facing a street, the architect will influence the perception and usage of the interior and exterior. Therefore we believe that the question of this thesis and our conclusions will follow us as architects, and be important, as long as we design residential buildings and areas in the future.

Bibliography

Brinkmann, S. (20200304). Brinkmanns Briks: Bo Bedre. [Radio]. Dansk Radio. <https://www.dr.dk/radio/p1/brinkmanns-briks/brinkmanns-briks-53/?fbclid=iwar1dkcx0hnlpwsqwx8fvefvc-55jvmhjhmldmbeztaqwyqjukvqwpkpbw>

Gehl, J. (2006). *Life Between Buildings*. 6. edition. Danish Architectural Press.

Gehl, J. (1976). *The Interface between Public and Public Territories in Residential Areas*. The Department of Architecture and Building, Melbourne University.

Gehl, J., & Gemzøe, L. (2004). *Public Spaces Public Life : Copenhagen*. 3. edition. Danish Architectural Press.

Hertzberger, H. (1991). *Lessons for Students in Architecture*. Uitgeverij 010 Publishers.

Jacobs, J. (1961). *The Death and Life of Great American Cities*. 1. edition. Random House.

Kärrholm, M. (2004). *Arkitekturens territorialitet : till en diskussion om territoriell makt och gestaltning i stadens offentliga rum*. Institutionen för arkitektur, Lunds universitet.

Minoura, E. (2019). *Bostadsgården : territoriell arkitektur*. 1. edition. Studentlitteratur.

Minoura, E. (2016). *Uncommon Ground : Urban Form and Social Territory*. KTH Royal Institute of Technology.

Wood, A. (20170729). Interview with Herman Hertzberger (2017): architecture as visual and social connection. *Architecture and Education*. <https://architectureandeducation.org/2017/08/29/interview-with-herman-hertzberger-2017-architecture-as-visual-and-social-connection/>

Whyte, W. (1980). *The Social Life of Small Urban Spaces*. 2. edition. The Conservation Foundation.

Illustration credits

Photo 1: Aronsen, N. F. (private picture). Permission according to email conversation 20210505

Photo 4: Aronsen, N. F. (private picture). Permission according to email conversation 20210505

Photo 2: Kopljar, S. (private picture). Permission according to email conversation 20210414

Photo 3: Marcus, L. (private picture). Permission according to email conversation 20210311

Remaining photos, illustrations and drawings are the authors private.



