



SMILES FOR FREE
myDO'S PLAYGROUND

ABSTRACT

This project was created in collaboration with the Melusi Youth Development Organisation in Melusi, an informal settlement located in Pretoria.

MYDO was formed in 2015 and since then provides the youth of Melusi with educational support and access to the working market, as the inhabitants in Melusi struggle with an unequal access to both.

Hlakudi, the founder, wanted to make sure that the huge potential, the youth in the settlement provides, does not go to waste.

Our intervention is the addition of a playground to the Youth Center. The space behind the main building showed a lot of promise and was already used for playing, but was not being used to its full potential.

Our playground aims to enhance the childrens creativity, while also providing the youth and the staff with a high quality seating and learning area.

The structure ties together newly added parts made from scrap materials and already existing structures, which were fixed and improved.

We want to thank the Melusi Youth Development Organisation, especially Hlakudi, Shane, Gladys and Thompson, but also everyone else supporting us through the process. Without everyone at MYDO, our project would have not ended up where it did.

We also express our deepest appreciation for the Melusi community, Sarah, who showed us the clinic and the University of Pretoria, for giving us insides and access to tools.

Lastly, thanks go out to CoSave Power-build in Pretoria, for donating material.

CONTENT

This is us

1

This is the context

2

Melusi

2

These are the goals

3

This is myDO

4

The Stakeholders

5

Stakeholder map

6

Timeline

7

These are workshops

9

Workshop 1

9

Workshop 2

11

Workshop 3

13

Need Finding

15

Workshop 4

16

Material Hunt

17

Inventory

18

This is Building

19

The Tuckshop

19

The Parkour

21

The Eiffel Tower

23

The tyre seatings

25

The tyre plant

27

Final outcome

29

Additional fixing

33

This is the future

34

Workshop 5

34

Evaluation

35

Future visions

36

Personal reflections

37

References

40

This is us



Juliane Freitag,
25 years old
Bachelor of science, Bochum
University of applied sciences



Joshua Hahn,
26 years old
Bachelor of science, Bochum
University of applied sciences



Matilda Johansson Santana,
24 years old
Bachelor of architecture, Instituto Su-
perior Técnico, Lisbon



Baïka Fournier,
23 years old
Bachelor of arts,
Haute École du Paysage,
d'Ingénierie et d'Architecture
de Genève (HEPIA)



THIS IS THE CONTEXT

melusi

Melusi is an informal settlement in Pretoria, the administrative capital of South Africa. It is located close to major industrial sites such as Coca-Cola. Because of its convenient location, many people move and settle here in the hope of finding work. The settlement is divided into three parts: Melusi 1, 2 and 3. On the edge of the settlement is a hill, which, during heavy rain, causes water to collect in the streets of Melusi. Rubbish and waste incineration are also major problems. As a result, the water becomes contaminated with toxic substances. MYDO is a youth centre near the main road in Melusi 1. The advantage is that this road is reasonably passable and a bus passes by regularly.



Theo Slabbert/Ave

Mayana

These are the goals

Reality Studio is guided by the **17 United Nations Sustainable Development Goals**. These represent an urgent call to all countries to ensure sustainable development at the economic, social and environmental levels. Through our project “Smiles for free”, we incorporate some of these goals directly or indirectly.



- Ensure healthy lives and promote well-being for all at all ages

Fun and a sense of community play a major role in an individual's personal well-being. On a playground, bonds and friendships are formed and strengthened. These relationships among young people form the foundation of the local community's future.



- Ensure inclusive and equitable quality education and promote lifelong learning opportunities for all

Playing and breaks are an essential part of a good education. A new playground encourages the children's creativity and imagination. Our project contributes to a quality and inclusive education.



- Ensure sustainable consumption and production patterns

All the materials used have been reused or repurposed. We have shown the local community how they can build to a high standard using what they already have. In this way, we are promoting sustainable consumption and waste reduction on site.



- Strengthen the means of implementation and revitalize the Global Partnership for Sustainable Development

Through the relationship with our local stakeholders, we have not only learnt from one another, but we have also been able to form lasting friendships.

This is myDO



Hlakudi Malatji, Executive Director and founder of myDO

He had the profound realisation that, without help, the brilliant potential of young people was at risk of being overshadowed by the harsh realities of their environment. The organisation did not arise from external funding, but from the collective will of local young people who refused to let their peers struggle to maintain a positive sense of self-worth amidst poverty.

What does myDO do?

Education program (after-school care)

A myDO staff member picks up the kids after school to bring them to myDO. There, they get help with their homework from teachers employed by myDO. There are different classrooms for the different age groups.

Youth empowerment and entrepreneurship

External teachers come to myDO to teach young adults from 19-28 skills in different work fields. Amongst other options, they get training in plumbing or solar panel installation. The focuses are skills development, entrepreneurship and life skills.

Sports, arts and culture

The kids can choose to do arts and theater or sports in their leisure time in the afternoon. A stage in the back of the property is the main area for theater and art, when the weather allows it. The kids in the sports program go to the netball field in the bush close to myDO.

Feeding scheme

With an empty stomach it is hard to learn and work for school, and proper nutrition is often a luxury in the Melusi community. This is why myDO decided to prepare warm meals for the pupils, so they are energized to start their homework.

myDO map

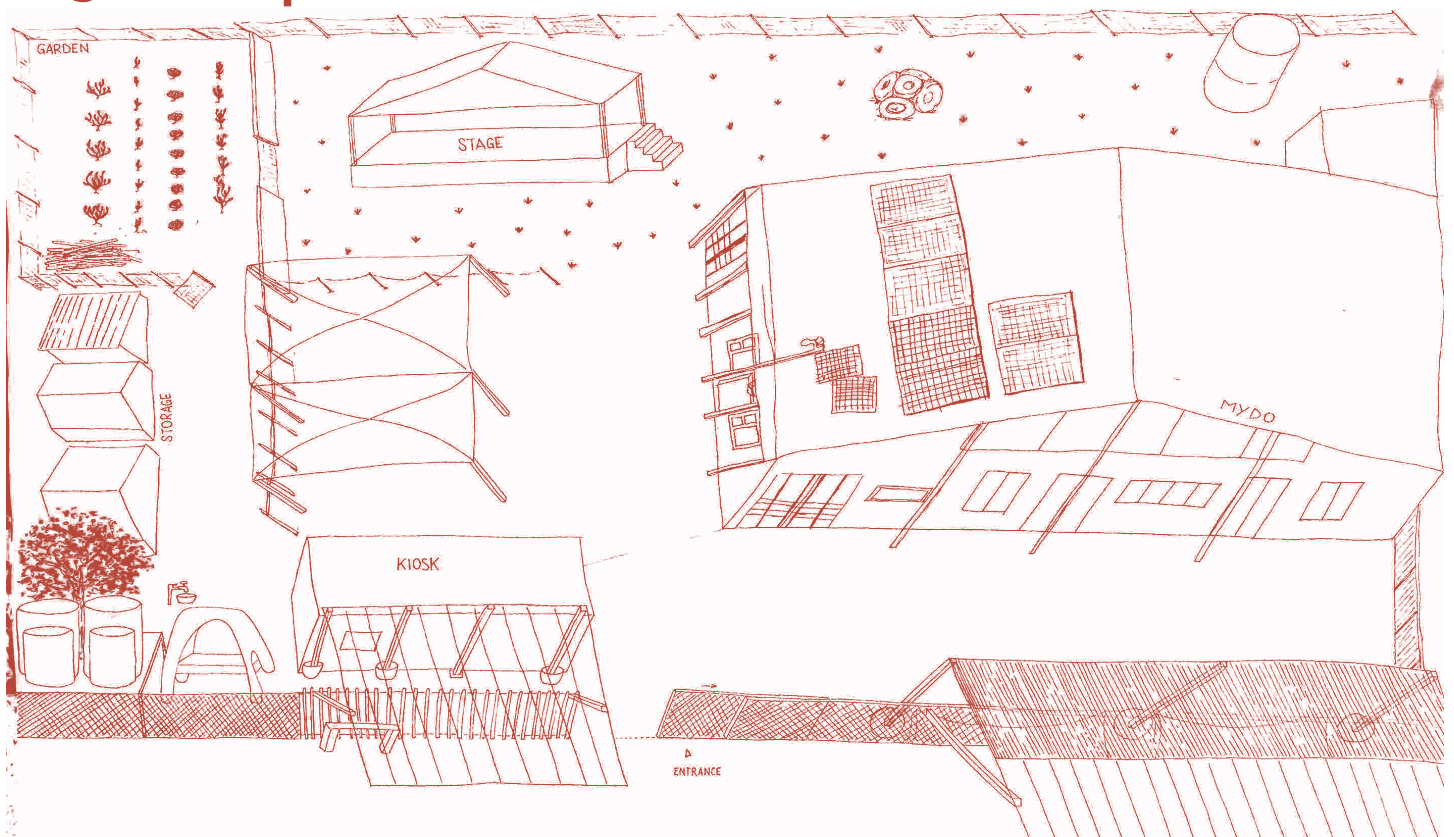

The Stakeholders

Shane was our main stakeholder and he was there for us during the whole process. Gladys organises the theater and arts with the kids in the afternoon. Her help was essential for workshops with kids. Thompson drives the kids to MYDO everyday and we were lucky to have him as our personal driver to go pick up wood, looking for a scrapyard or just the hardware store. Hlakudi "the big boss" knows everything going on at MYDO. To get the final approval for all our plans, we had to go through him first. He was a big help to get information about everything we had to know about the property, the management, maintenance and he was able to share his experience in the field with us.

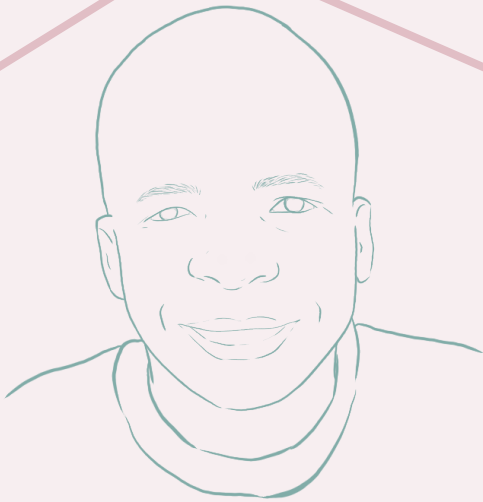

Hlakudi Malatji
Executive Director

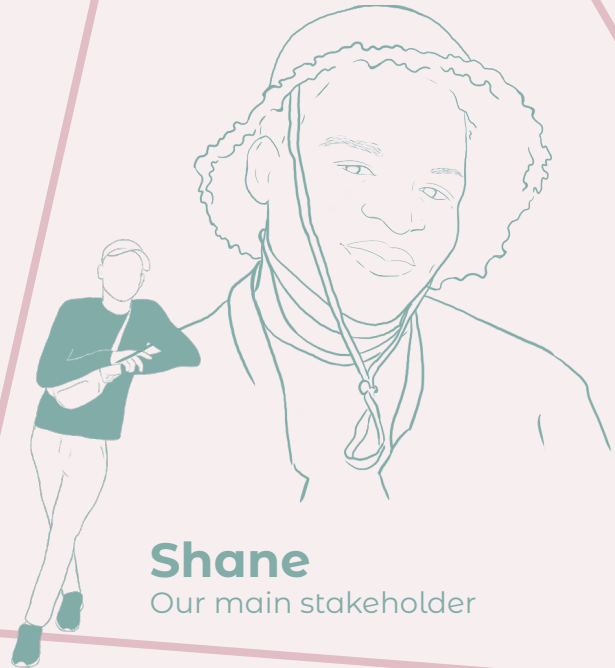

Shane
Our main stakeholder

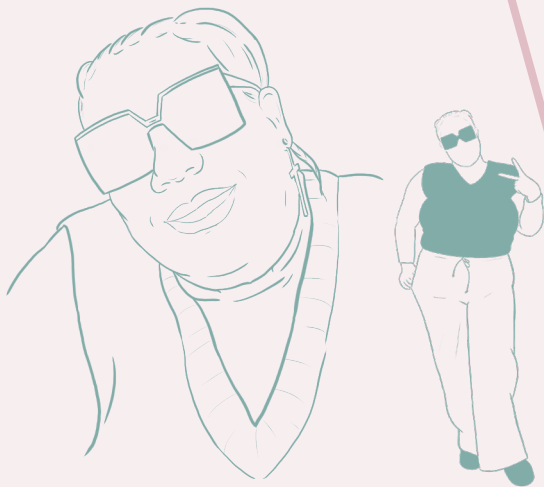

Gladys Thaane
Human Resource &
Administration Director

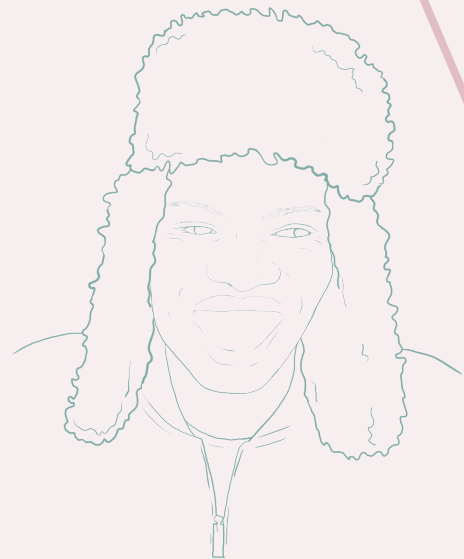

Thompson Sekuru
Finance & Programmes Director

Stakeholder map



TIMELINE

Formation of „Banyana Bafana“
26.03.



Start of the course in Hammarkullen
23.03.

First visit to Melusi
08.04.



Site visit with UP in Johannesburg
14.04.



Embassy visit
17.04.



UP campus tour
20.04.



05.04.
Travel to Pretoria

10.04.
Walk-and-talk workshop in Melusi with Gladys and Shane

16.04.
Need-finding Workshop with the MYDO staff

18.04.
Workshop with the kids with games and snacks

21.04.
Start of phase of scrapy visit

24.03. - 02.04.
Analysis of literature and exploring workshops



Project related events
Supporting Events
Workshops



Model making at UP 28.04.

Material hunting 28.04.

Opening and Exhibition at MYDO 07.05.

The MYDO staff expressed their inspiration and will to further expand on the playground Future

design and ard

24.04. Co-Design workshop with Shane and Hlakudi

29.04. Start of building phase

06.05. Last building day and Fixing the stage

10.05. Travel back to GBG

29.05. Exhibition



THESE ARE WORKSHOPS

Workshop 1

Method used

Walk and talk

The method involves engaging with neighborhood residents through conversations, sketching, mapping, and photographing areas of interest in order to gain a brief overall understanding of the neighborhood from a representative sample of the community.

WHAT: MYDO Staff showed us around in the informal settlement.

WHOM: MYDO Staff: Thompson, Shane, Gladys | **Clinic Staff:** Sarah | **Happy Sabby Staff**

WHEN: Friday 10th of April 2026, Week 1 in South Africa

GOAL: To get to know the MYDO staff and get a general understanding of Melusi

FIRST IMPRESSIONS



MELUSI 1



The first interactions with Melusi and MYDO taught us a lot on how the settlement works.

Coca Cola Factory

Main entrance to Melusi

R514 Main Road

Pretoria Center

Hill

Western entrance

Western entrance



Workshop 2

Defining the needs

Method used

Asset Mapping + Future Visioning

This method involves people connected to a place, such as community members, youth, staff, local stakeholders, designers, and researchers, mapping existing activities, resources, and experiences, then collectively imagining future possibilities to understand current conditions, identify strengths and needs, and generate shared ideas for improving the space and community.

WHAT: Ask MYDO staff what their needs and priorities are

WHOM: **myDO Staff:** Thompson, Shane, Gladys, Johanna, Kgabo, Sheila

WHEN: Thursday 16th of April 2026, Week 2 in South Africa

GOAL: To identify the needs and understand where we could have an impact

General overview

of the needs that were identified during the workshops

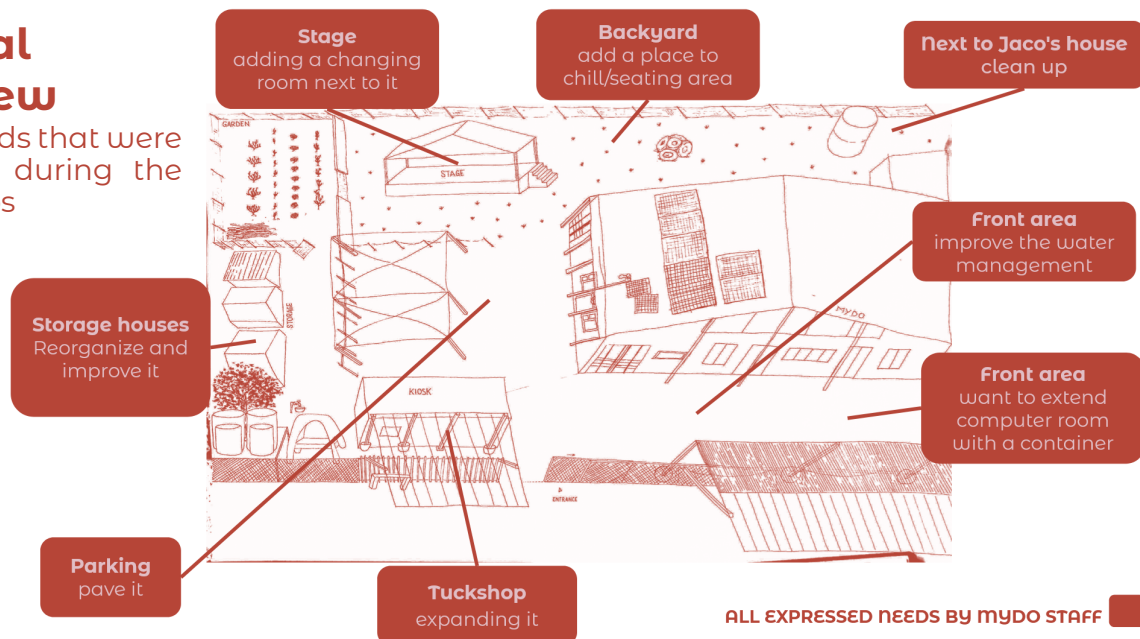

Process

How do you use the space (rain, security, sun, events)?

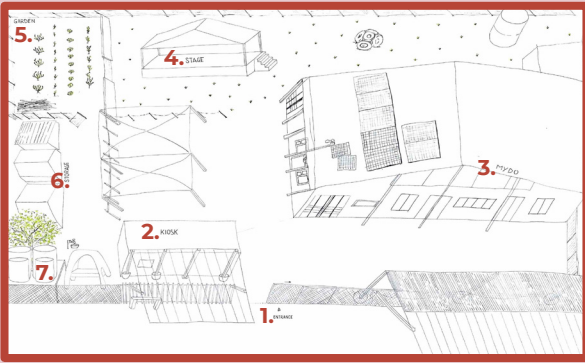

MYDO Perspective map

3D map, in perspective where it is possible to see all the elements of MYDO:

1. Entrance from the street
2. Kiosk
3. Mydo main building
4. Stage
5. Garden
6. Little storage houses
7. Water tanks

Things that work:

They mentioned that the garden, the shade in the parking, the shop, the front space and the backyard work well.

Things that work

Things that do not work:

The parking needs paving, the storage needs to be reorganized, the solar panels need to be repaired and they would like a play area in the backyard.

Things that do not work

What works and what doesn't work?



MYDO map with post-its of what works and doesn't work

What are the improvements you can think about for MYDO?

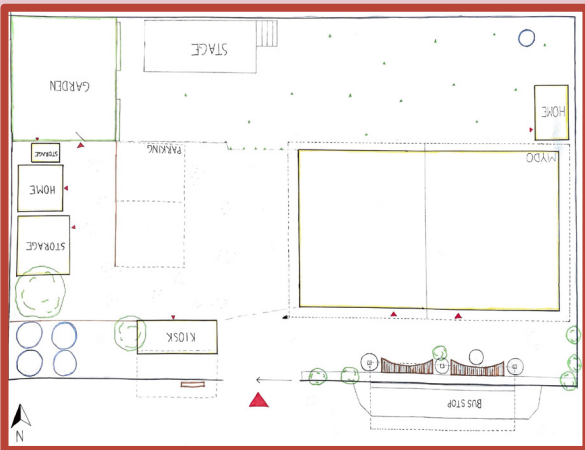

MYDO plan

Improvements mentioned by MYDO staff:

- Stage: adding a changing room next to it
- **Backyard: add a place to chill/seating area**
- Computer room: be able to ventilate them
- Roof leaking: fixing the leaking
- Front area: want to extend computer room with a container + improve the water management
- Tuckshop: expanding it
- Next to Jaco's house: clean up

The last question was about prioritizing, what the most important or urgent intervention is for each of the staff members. The solar panels got a lot of stars as well as getting an extra computer room at the front of MYDO. We had to manage the expectation and focus on an intervention that would be realistic with the limited time we had on site.

★ Priority
Improvements

What is the priority?

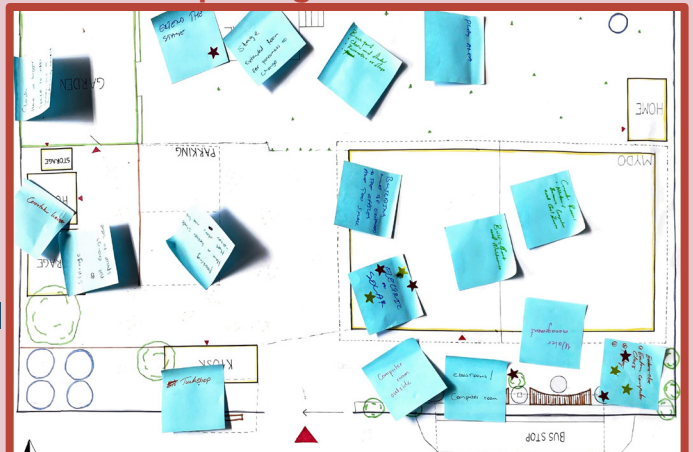

MYDO plan with improvement post-its

Workshop 3

With the myDO Children

Method used

Dream drawing

This method uses a drawing exercise in which participants draw out their "dream house" or "dream space" as they would like it to be. It is a way to understand qualities valued and/or wanted/required in dwellings

WHAT: Ask the myDO kids to draw their dream playground and bond with them.

WHOM: myDO kids: around 30 kids

WHEN: Saturday 18th of April 2026, Week 2 in South Africa

GOAL: To understand what their wishes is for their future playground

The goal with the workshop was to bond with the kids as well as getting to know how they wanted their play structure to look like. Doing the workshop on a Saturday was a way to not interfere with their weekly schedule which is already very packed with school, homework and extra curricular activities like arts or sports. The workshop had a station turning format, where we had a dream drawing, a game playing and a chess teaching station.

1 Dream drawing

The workshop was about asking the kids what their dream playground would look like. The kids then drew their wishes on a white paper.

2 Games playing

This station was about sharing the different games that we play with each other. The goal was to share experiences but also to understand how the kids use their imagination and space around to play with. The games that we ended up playing were Green light/Red light, Mamman Pouille pouille, Marco Polo, Try to find the bottle and Loup galcé.

3 Chess teaching

The chess station was about teaching the kids how to learn chess. We wanted to understand if chess is something we wanted to integrate in our future design.





Group picture with all the kids and staff that participated in the workshop

THE KIDS DRAWINGS

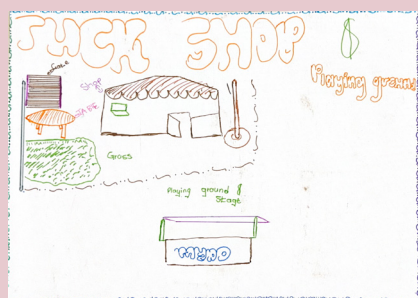
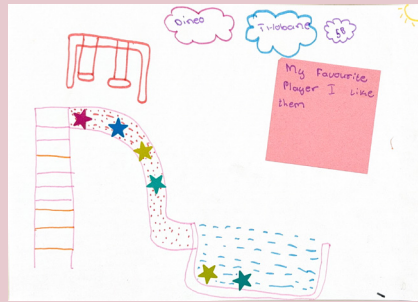
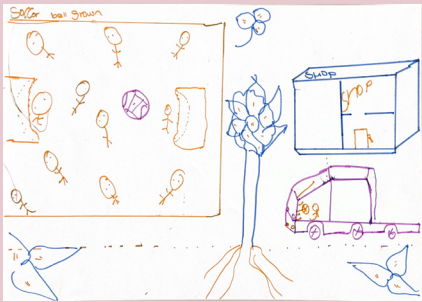

Need Finding

BIG INTERVENTION

to the MYDO building

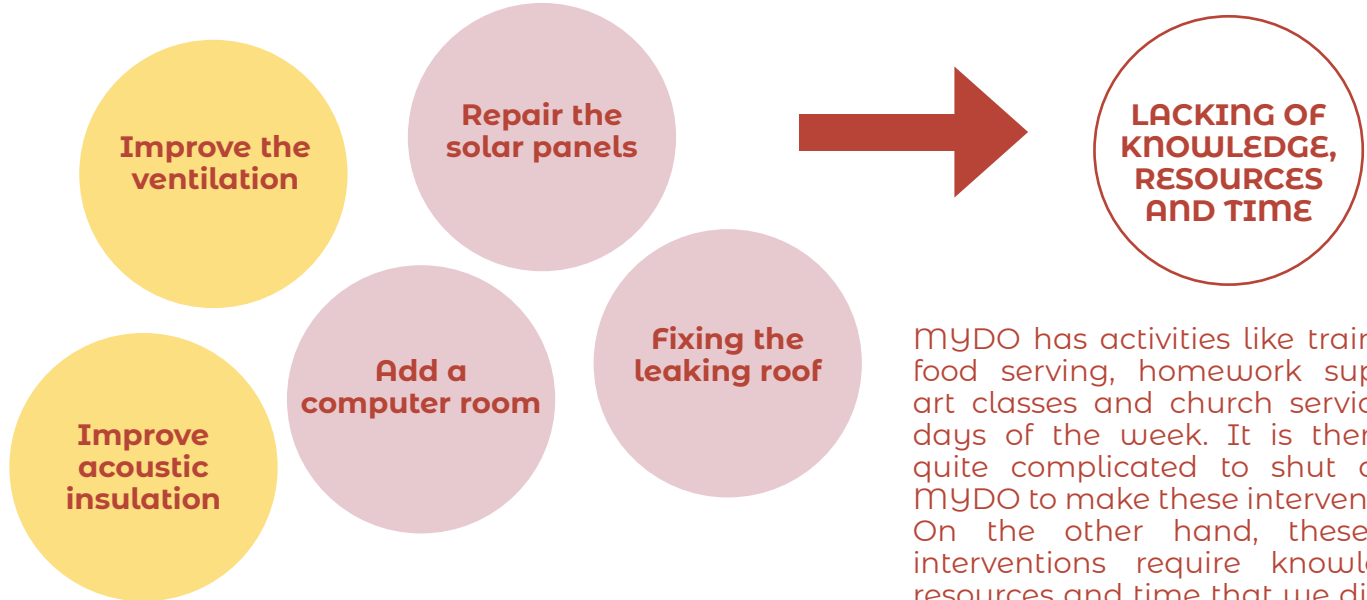

MYDO has activities like trainings, food serving, homework support, art classes and church service all days of the week. It is therefore quite complicated to shut down MYDO to make these interventions. On the other hand, these big interventions require knowledge, resources and time that we did not have.

DOABLE INTERVENTION

to MYDO's outside

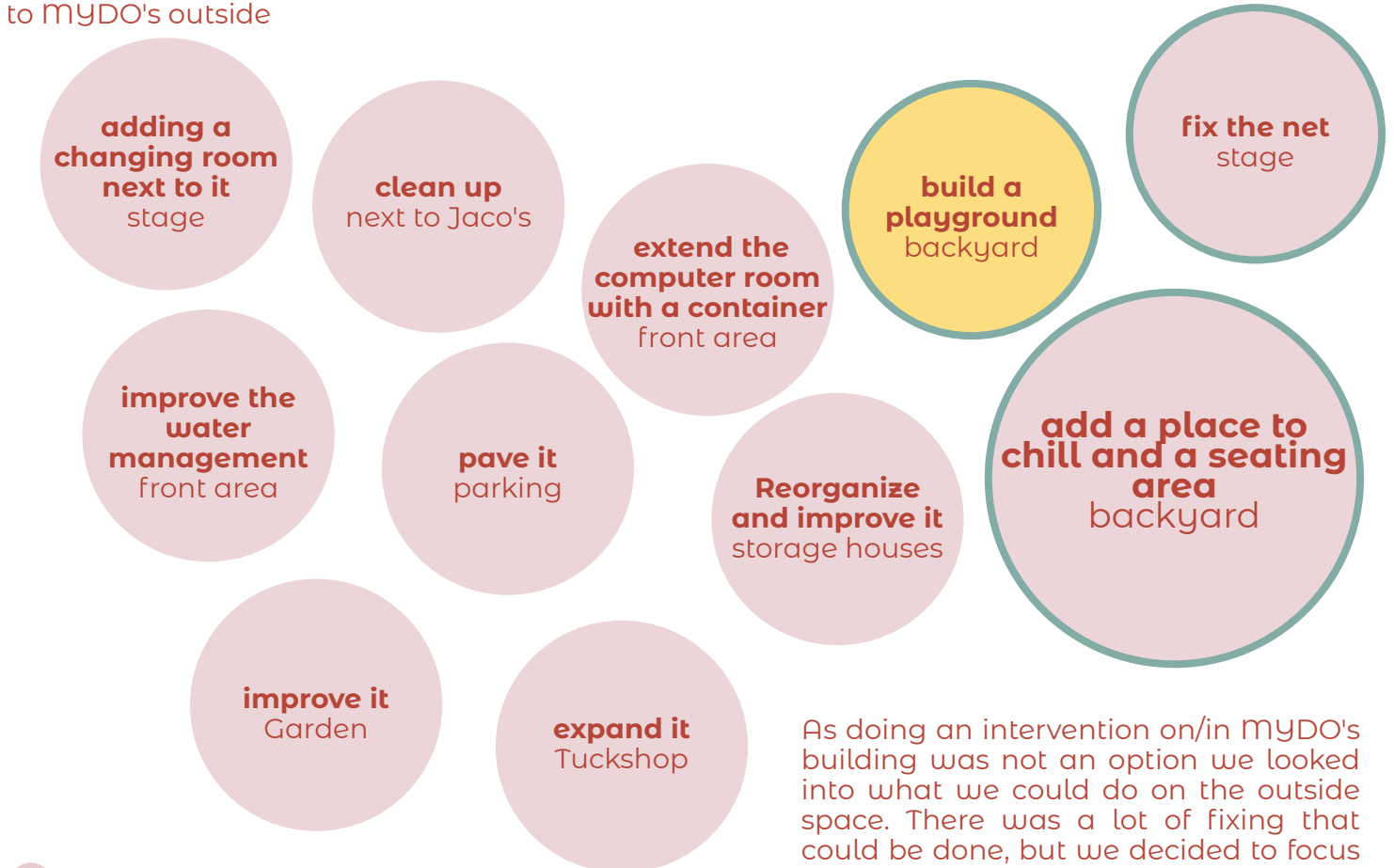

As doing an intervention on/in MYDO's building was not an option we looked into what we could do on the outside space. There was a lot of fixing that could be done, but we decided to focus on the backyard space and on adding a place to chill, some seating as well as having a playground. We also had time to fix the net at the back of the stage.

- Expressed needs
- Latent needs
- Resolved with our project

Workshop 4

Co-Design

WHAT: Brainstorm ideas together with the stakeholders for the future design

WHOM: MYDO Staff: Shane, Hlakudi

WHEN: Friday 24th of April 2026, Week 3 in South Africa

GOAL: To get a better overview of what the design will look like and being on the same wave length as the stakeholders

1 LIMITATIONS

We started with laying out the limitations of the backyard with the help of Shane and Hlakudi. There is a place they use to do events at least once a month. The truck also comes once a month to access the toilet hole. The space in front of Jaco's house has to be accessible and the water as well. We ended up having this red rectangle available for our project.

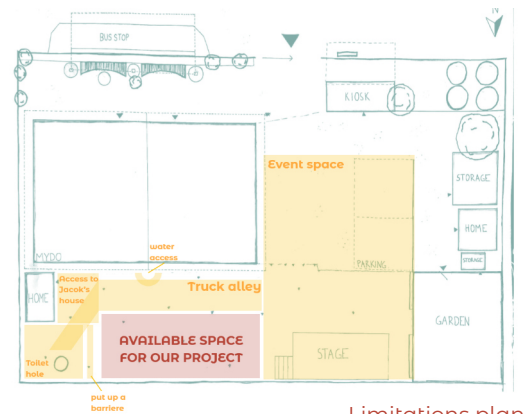

Limitations plan

2 CO-DESIGNING

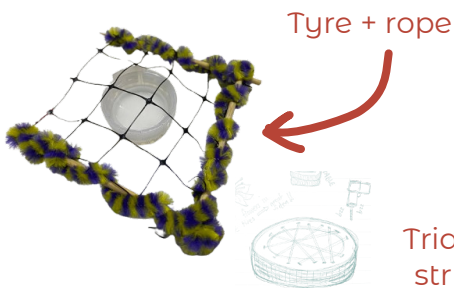

Tyre + rope

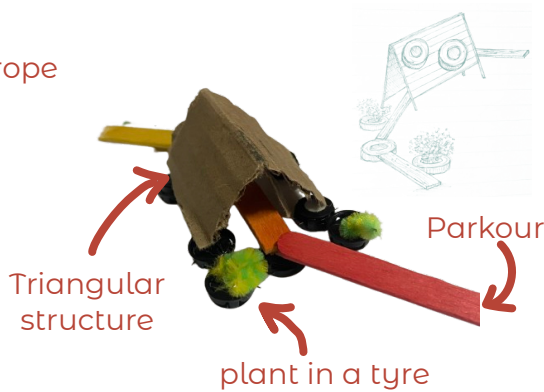

Triangular structure

Parkour

plant in a tyre

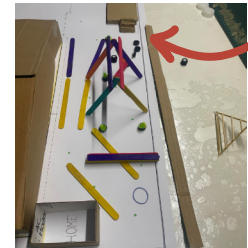

buried in tyre

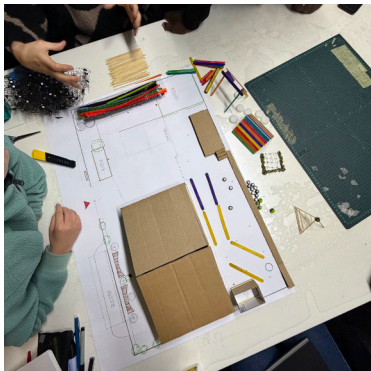

The co-design workshop was based on a 3D physical model where we first mapped out the limitations. Once we had our available space, everyone moved around the elements to come up with an idea of a layout of the playground. The ideas that emerged from this workshop were the tyre and rope seating, the triangular structure, the plant in the tyre, the parkour elements and the buried tyre. MYDO's staff also made very good comments that we should have in mind, which were: keep ability to cut the grass around the elements so the snakes can not hide in the high grass and also that slides and swings require safety measures that were too much for us to handle.

Material Hunt

After finishing the workshops and drawing some first drafts of the design, we wanted to continue our frugal approach by letting the found material dictate design decisions. Before deciding on any structural design we needed to figure out materiality and longevity of certain choices. Another factor we were concerned with was ensuring our material was “kid-friendly”, so any wood had to be nail free, sand and paintable and we had to ensure a certain stability, as breaking wood could be splintery. Sharp edges were another concern, as well as slippery surfaces. Our approach was to stay close to the area with our sourcing, to ensure that our prototype could be realistically reproduced within the settlement.



We were lucky, that Thompson could find time in his busy schedule to take us to a few places to pick up material. As you quickly learn in the settlement, not everything can always go to plan. On that day, the MYDO car, which is usually used to pick up the kids from school, needed a bit of a jumpstart.



At CoSave Powerbuild, a local hardware store, we first looked for all the tools and connectors we needed, as these were not possible to be recycled. We also realised, that they had left-over paint cans at reduced prices, which, after asking, we got donated. They also hinted towards another place close by where they stored loose material and scrap wood, where we were able to pick up some palettes and wooden planks.

Our last stop was Africa Scrap Yard, a big yard specialized on metallic waste. We were quite unsure at first, if we could find material that was both possible for us to work with and also kid-friendly. We were lucky to find metal sheets in very good condition with rounded corners.



Inventory

Bought at



Paint rollers
78R



Paint brushes
35R



Nylon rope 40m
138R



Nails 200g
22R



Screws
42R



4 Plants
240R



Fertilizer 5kg
27R



Soil 30l
88R

Donated by



6 Cans Paint

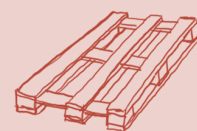

Palettes

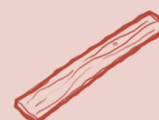

Wood planks

Bought at

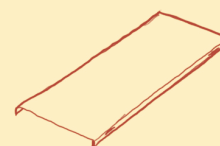

Metal sheets
150R

Found at **myDO**

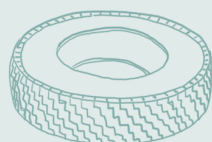

Truck tyres



Car tyres

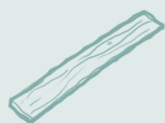

Wood planks

TOTAL COST

Material 820R / 470 SEK
 Ubers to Melusi (13 days) 3000R / 1700 SEK
3820 R / 2170 SEK

To form our inventory we used different sources to get materials. Some of the central building materials were found at the myDO site. For tools, paint equipment, connectors and gardening we went to a local hardware store, CoSave Powerbuild, just outside of the settlement. Here, upon asking, we also got paint, recycled wood and palettes donated at no cost. Lastly, we went to Africa scrap yard, a big local scrapyard for mostly metallic waste, and picked up three sheets of metal. Here we paid a certain amount after weighing the material.

THIS IS BUILDING

The Tuckshop

The design process

The idea for the shape of the tuck shop was one of the first things we started designing. A simple shape that could be easily integrated into the wider structures of the playground wasn't actually intended to be a tuck shop at that stage. Creating another spot where children could climb whilst playing was one of our goals. As we didn't yet know exactly what materials we would be working with or what would be possible during the design phase, we made many design decisions during the build. When we found the cut-open tyres, the idea arose to transform the entire structure into a tuck shop. With a few brush-strokes, this idea then became a reality.

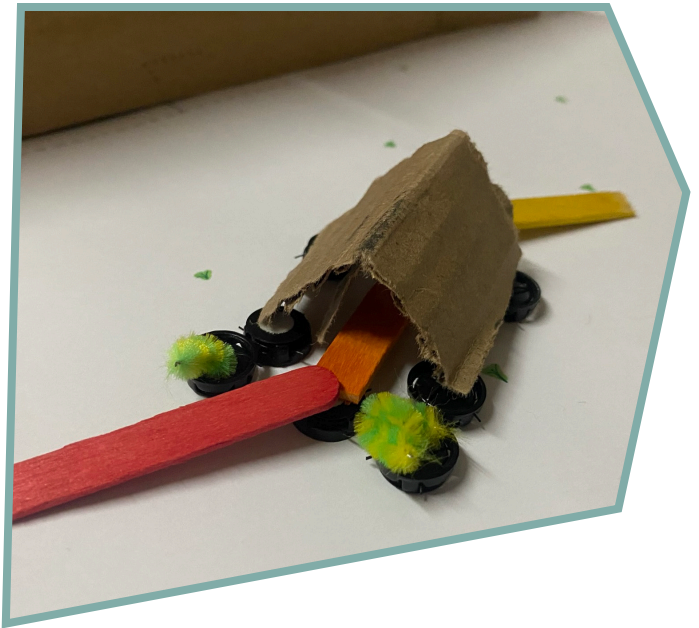

The building process



The material



The outcome

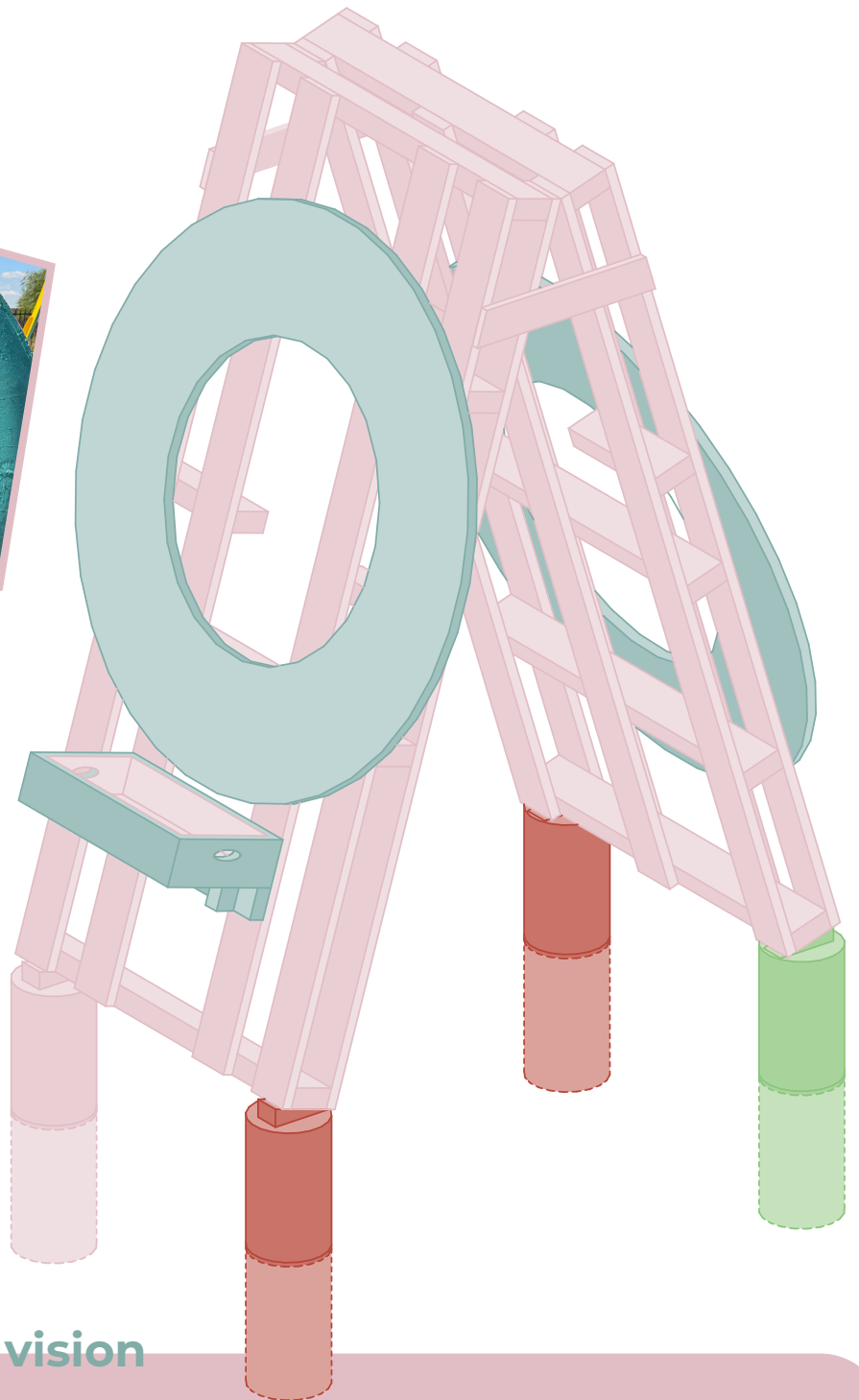

Feedback and Future vision

The construction of the structure went smoothly. Concerns about its stability proved unfounded. Even when several people were climbing and shaking it, nothing budged. The children also seemed to like the design. At the playground's opening, imaginary ice cream and popcorn were being sold enthusiastically in the mini tuck shop. Children climbing the parkour course also crawled through the tuck shop to reach their destination. As all parts are bolted together, the entire structure can be dismantled again, or parts replaced and repaired. It serves as an example of what can be built with very little material.

The Parkour

The design process

The parkour acts as the connecting element between the various structures in the playground. This allows the children to experience all the individual structures as part of a continuous obstacle course. Exactly what this structure should look like was still very unclear at the start. The structure, made up of tyres, wooden beams and sheet metal, only took shape once we had compiled our inventory through the 'material walk'. So we designed the entire obstacle course as we built it. In the process, we noticed that the metal surface heats up quickly. So we decided to paint it white, which worked really well.

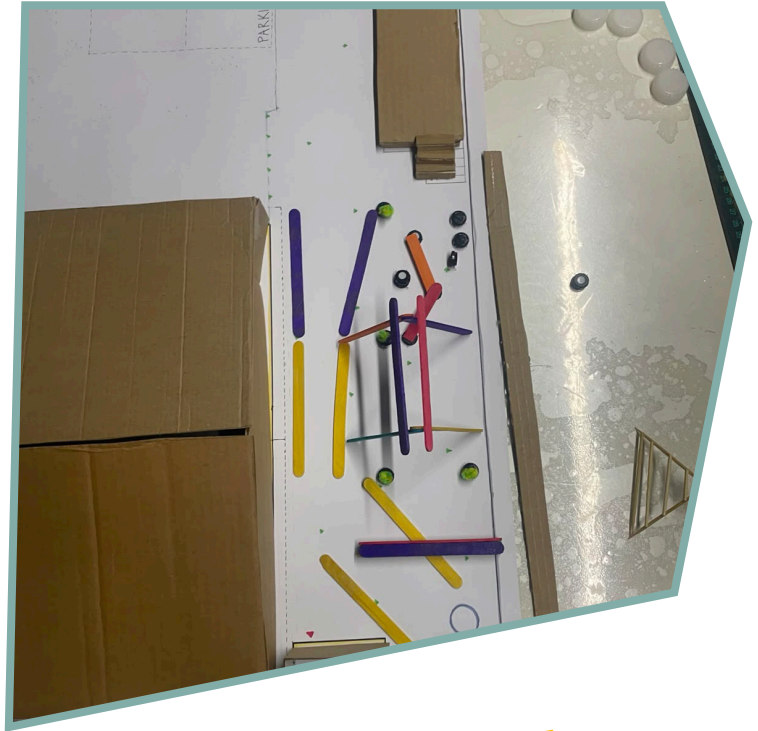

The building process



The material

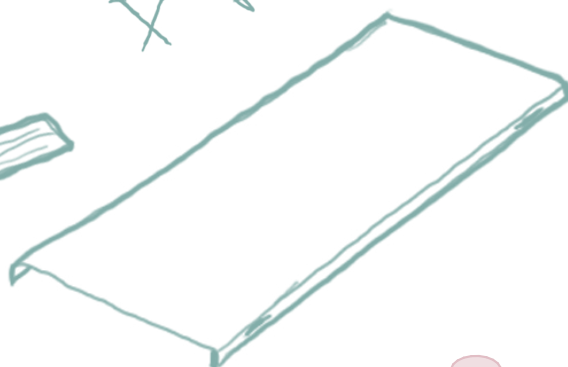
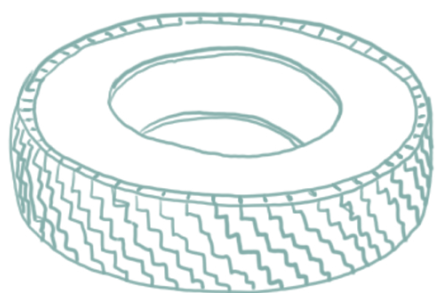

The outcome



Feedback and future vision

After the handover, we began the first test of all our structures by letting the children try everything out. The children ran and jumped across the course. The bridges were also used as places to sit. Overall, the structure was very well received. As the obstacle course is very simple in design, it is also easy to extend. The structure can also be continued using other materials. Another way to scale it up would be to stack several hoops on top of each other, thereby creating a higher bridge and adding a new dimension to the whole thing. We explain exactly how to build it in our manual (Appendix 12).

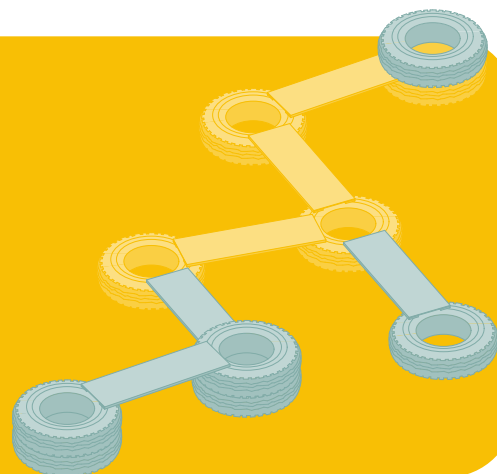

The Eiffel Tower

The design process

We repaired and relocated the structure that Mydo affectionately named the Eiffel Tower. We wanted to design it frugally and use as many existing materials as possible. The Eiffel Tower was a bit run-down and needed a makeover to look inviting again. We repaired and reinforced a broken section. Some new paint gave the whole thing a fresh new look. The entire structure now stands at the end of the playground and can be used by the older children to chill, or by Gladys, who looks after the children.



The building process



The outcome



Feedback and future vision

The newly positioned Eiffel Tower was well received by the children. The staff at mydo also enjoyed sitting there, and we even used it as a table for eating and taking breaks whilst it was being built. We had to take the Eiffel Tower apart to move it. Although it requires several people, the principle was quite simple, so the structure can be dismantled again if necessary or reassembled elsewhere. At the moment, the structure has a table and a bench, but it can be expanded further. Thompson has already announced plans to add a new table and a new bench. The wood for this was already available at MYDO and he now has the know-how too.

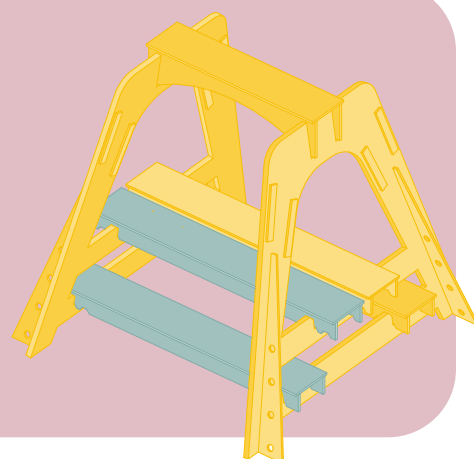

The tyre seatings

The design process

The initial idea for the tyre seats came about during our co-design workshop with Shane and Hlakudi. Shane had the idea of creating a comfortable seat by fitting a net inside the tyre. After a bit of trial and error, we were able to put this idea into practice. While building them, we noticed that rainwater was collecting inside the tyres, which started to smell. So we drilled holes in the underside of the tyres to allow the water to drain away. That worked really well. We tried out a few different patterns for tensioning the rope and eventually settled on a zigzag pattern.

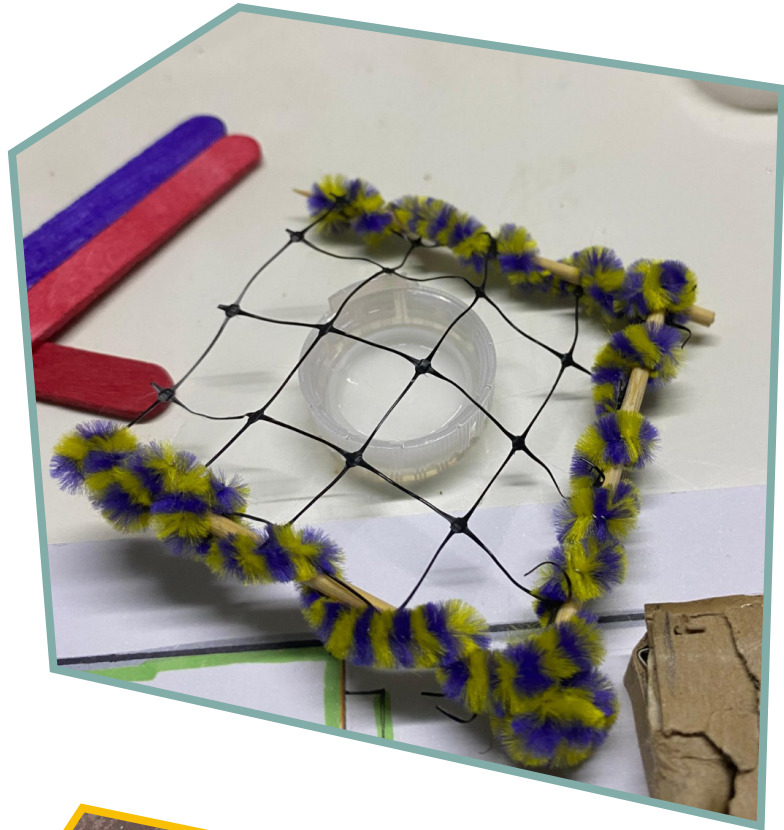

The building process



The material



The outcome

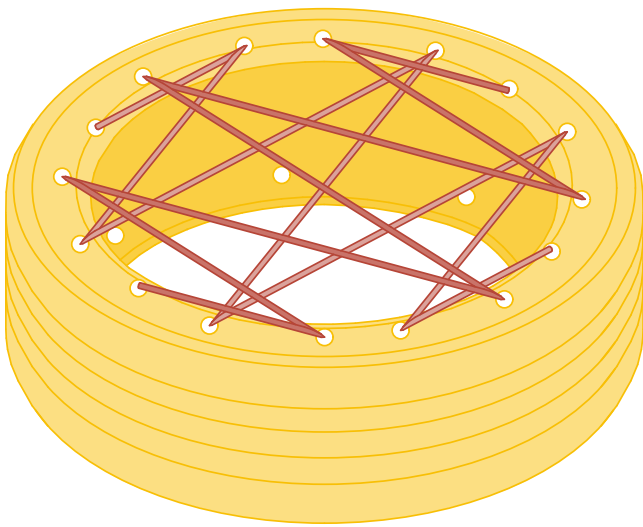

Feedback and future vision

During the construction phase, we regularly sat on the new seats, as they had the advantage of drying quickly and were very comfortable too. The children then gave them an additional function. The children rolled the tyres around and used them as 'cars' or 'taxis'. It was very inspiring to see how many different things the children could come up with in the playground. You can read how to build these seats in our handbook (Appendix 12). We have passed this on to MYDO, and as Shane was also involved in the construction of the seats, it is quite possible that these seats will be reproduced. They can be used not only outdoors, but also indoors and throughout Melusi.

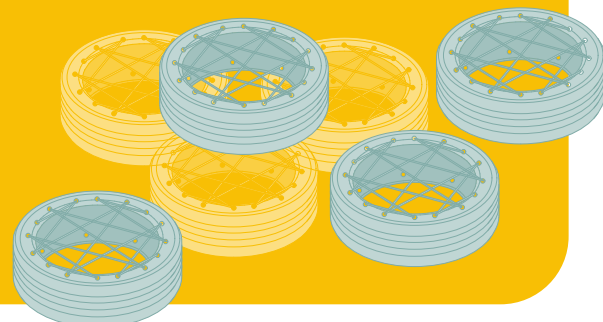

The tyre plant

The design process

Planting a plant in a tyre was one of our ideas right from the start. However, for a long time we weren't sure whether we would go ahead with it, as it wasn't clear who would look after the plant. After talking it over with Gladys, she assured us that both she and the children would take care of it. In an educational playground, all the senses are engaged, and with the lavender we have introduced a new scent to MYDO. We also drilled drainage holes in the base of these tyres before filling them with soil, some of which was already present at MYDO. We also added fertiliser.



The building process



The material



The outcome

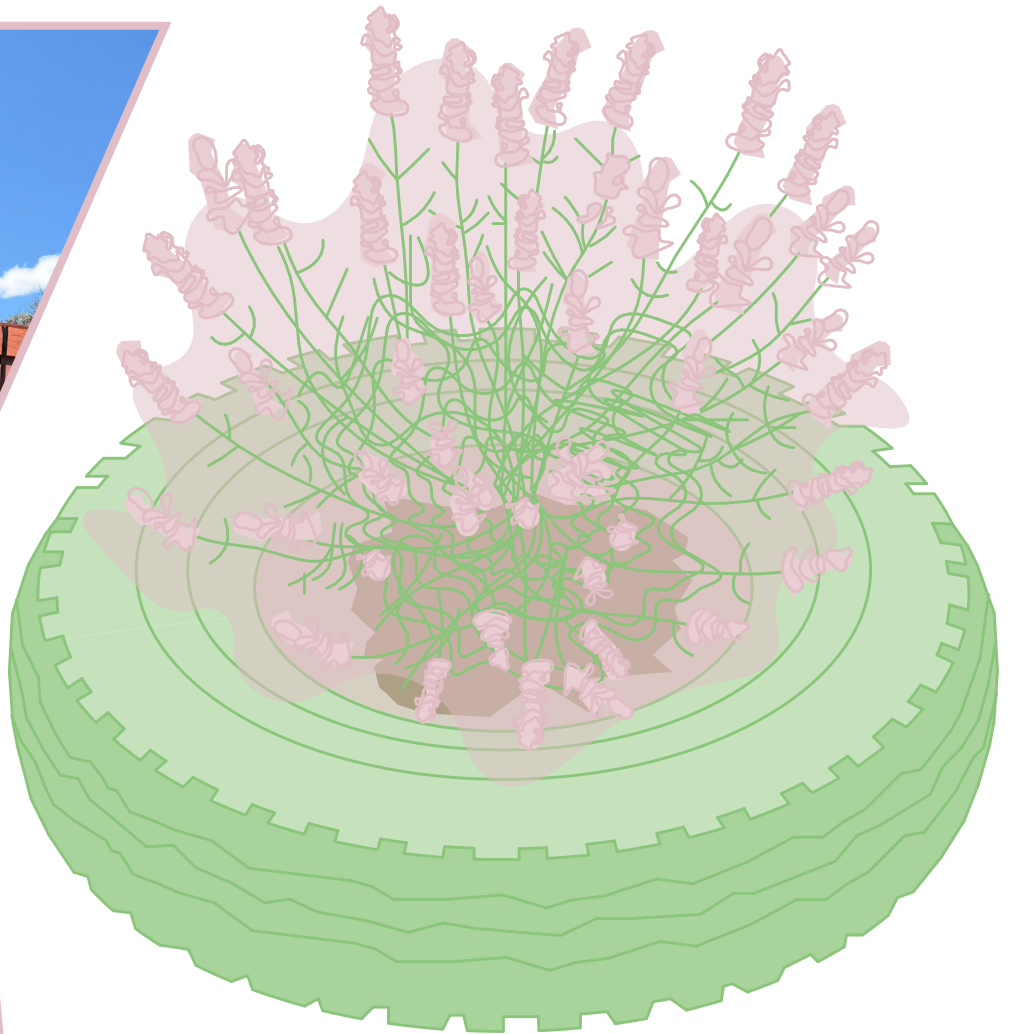

Feedback and Future vision

The plant was well looked after and admired at the playground's opening. Although the children were more interested in romping about on the new structures, a few of them did stop to smell the lavender. We have included this element in our handbook as well. This method could be particularly promising for herbs. All the materials needed to build another herb garden are already on mydo, apart from the plant itself.



Stage

Legend

- 1 The parkour
- 2 The mini tuckshop
- 3 The seating tyres
- 4 The planting tyre
- 5 The tyre structure
- 6 The buried tyres
- 7 The Eiffel Tower

Final outcome

Zoomed in plan of the project

Scale: 1/50

myDO



4

5

6

3

7



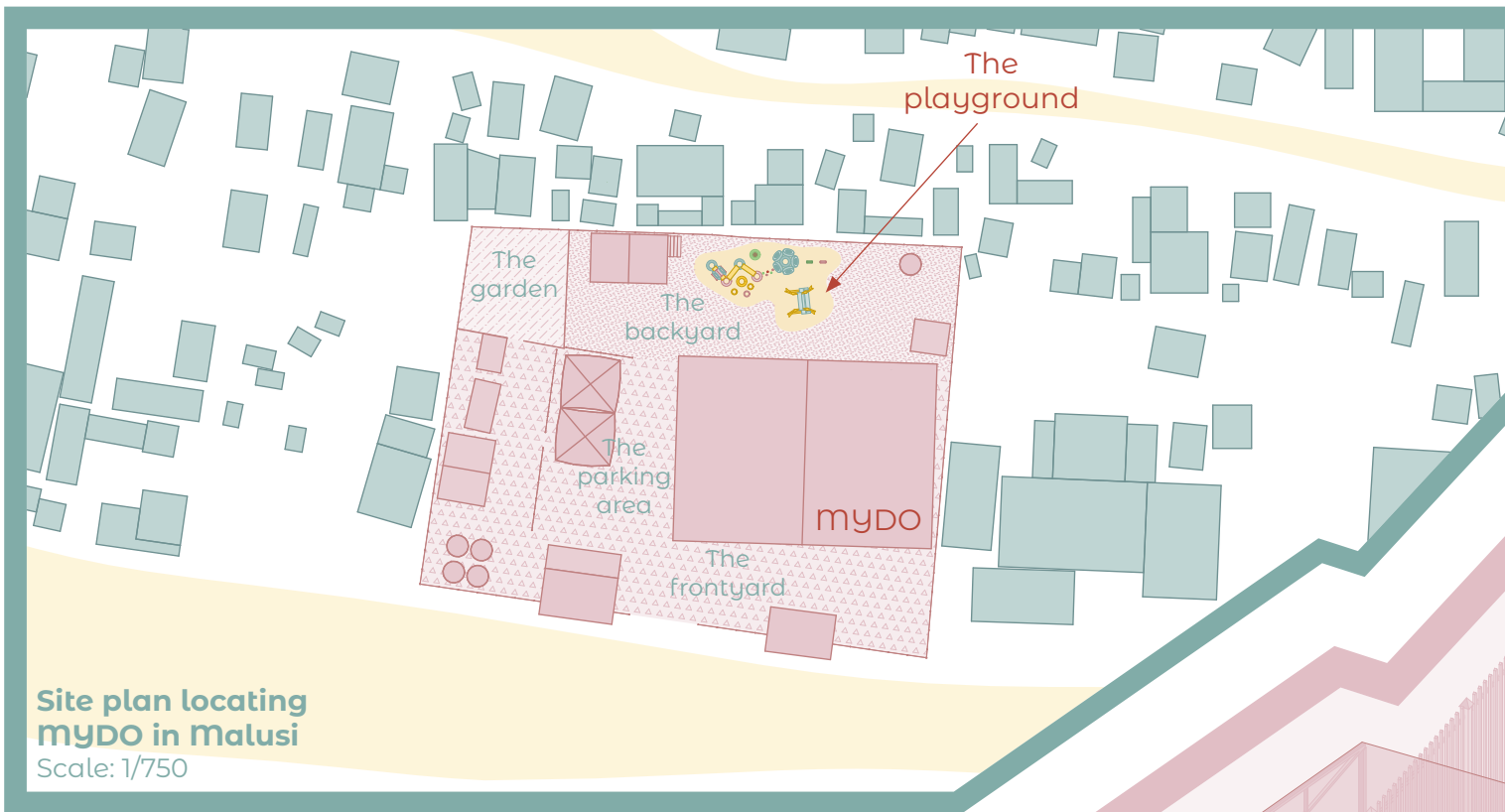

Site plan locating myDO in Malusi
Scale: 1/750

Building and laughing together

After the co-design phase, came the co-building phase. During our numerous workshops and after a lot of brainstorming together, we found out that myDO's backyard was lacking a place for the kids to play and sit. In order to bring some life in this area, a playground was created. Since our project relied mostly on a frugal approach, the project evolved as the days passed by depending on what materials we were able to find, how much time we had to complete each element of the playground and, of course, the project was shifting according to the inputs and discussions we had with our stakeholders. The final design proposal is therefore the result of a close collaboration between our group and our stakeholders from the very beginning of the design process and we can clearly acknowledge that the final outcome of the project is a combination of ours and our stakeholder's ideas. Everyone who worked on this colorful playground can thus clearly see themselves reflected in certain details and some specific elements of the final result.

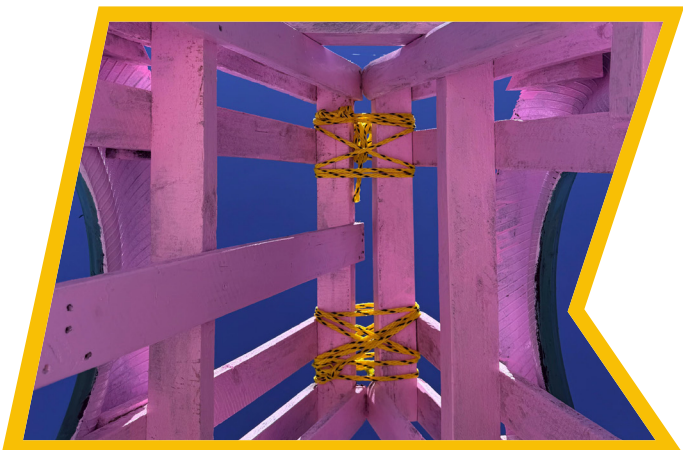
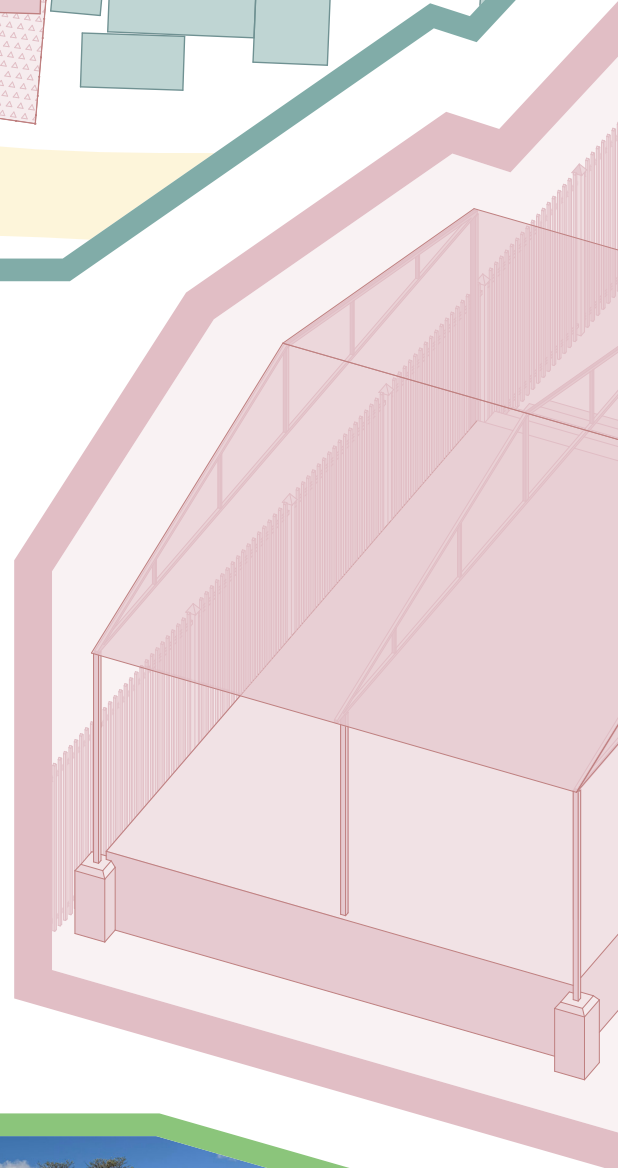



Where is the fun ?

The location of the final outcome of the prototype, situated in MYDO's backyard, was determined by practical parameters that were specified by the stakeholders during workshops.

An inspiration for all ages

In total, the playground took 5 working days to complete and was built in collaboration with Shane, Gladys and Thompson. The playground aims to inspire the kids and the stakeholders to dream big and see that, by using discarded materials already laying around, it is possible to create a colorful and fun project. Sometimes, all you need is a good idea, some tyres and a lot of smiles to build a simple (yet very cool) playground ! By using their imagination, the kids will take ownership of the project and use the different elements in accordance to the games they will play.



Additional fixing

Fixing the stage

The stage was one possible intervention project to work on, as MYDO uses it a lot for events and theater classes. While we decided against expanding it, we wanted to fix the broken textile at the back of the stage, as it was completely ripped up. Especially Gladys, who is responsible for the theater group, was very happy about our effort.

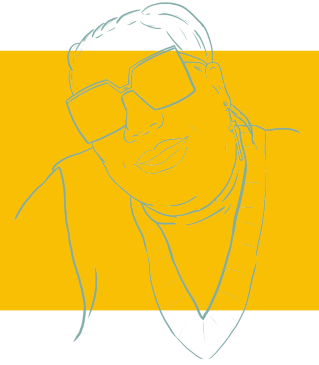

BEFORE



The stage is one of the prominent structures when entering the MYDO site and is used for representative events. Unfortunately, in the condition we found it in, it was obvious that the left side textile needed changing. When taking the ripped up side off, we realized that all individual textiles were fixed with the same cords. To enable easier fixing of single sheets, we fixed them individually.



As the textile got ripped up by the spikes on the fence behind it, we fixed a wooden plank on the inside of the fence, to protect the textile. As we had a bit of textile left over, which we purchased together with the other group working at MYDO, the staff was already thinking about also fixing parts of the right side of the stage.

AFTER



THIS IS THE FUTURE

Workshop 5

WHAT: Asked for feedback of the playground to MYDO's staff and hand the project over

WHOM: myDO Staff: Shane, Gladys & Thompson

WHEN: Thursday 7th of May 2026, Week 5 in South Africa

GOAL: To get a better understanding on what we could improve in the process and in the future.

FEEDBACK SESSION

On the feedback session we handed out this sheet with different questions. Gladys, Shane and Thompson could then answer with the smiley bar. We got very positive feedback on all the questions. Another feedback that we got was that all the skills they learnt will not go to waste and we feel the same way. Last but not least, we all really liked the final result and learnt that we had to trust the process.

FINAL HAND OVER

On the last Thursday we had a final presentation as well as a hand-over of the project to MYDO. We organized this day with the two other groups working in Melusi: the Water management group and the Clinic group. We inaugurated the projects by cutting the red band, offering flowers and gifting a photo collage to the stakeholders. This was a day full of emotions, and happiness. The whole experience was a learning curve for us all, sharing the knowledge and ideas throughout the project. We were all very thankful to have had the opportunity to work with each other as well as creating such nice friendships.

Evaluation Reality Studio 2026
MYDO Playground

The playground fits well into the space. [Smiley bar: 4/5]

The playground is safe. [Smiley bar: 5/5]

The playground fulfills the needs of children. [Smiley bar: 5/5]

The playground is easy to monitor. [Smiley bar: 5/5]

The playground will be easy to maintain. [Smiley bar: 5/5]

I am happy with the design and building process and felt included by the students. [Smiley bar: 5/5]

I am happy with the end result.
Yes I am happy with the result because when you finish something it's the little things but when we get into action it's when we see the final result.

Additional notes and comments:
I just want to thank you and Mydo also off a team for this opportunity because I learned a lot but I love to be creative and I also like to thank you guys for the team.

THANK YOU!!! [Signature]

Feedback Sheet



Clinic team, water team, playground team, MYDO staff and Sara

Evaluation

Reactions of myDO's Children

TESTING OUT THE PLAYGROUND

The kids had finally the chance to play on the playground and they loved it. The tires became taxis, the tuckshop was selling a lot of ice cream and the parkour was getting jumped over by a lot of little feet. They used it in a way that the playground functions like a mini settlement.

Some observation we made about things that worked well was that the tyre structure didn't smell bad anymore because there was no more stagnating water. The white paint on the metal sheets were ruff and therefore not slippery. The kids jumped from the eiffel tower down to the higher grass, which was acting like soft landing.

On the other hand some improvement could be made. The bucket on the front of the tuckshop could be better fixed because the kids are hanging on it. The dug in tyre should not be painted in the middle strip in order to have more grip. The metal sheet is very jumped on and should therefore be reinforced with more woodstrips underneed.



Future visions

We planned our project in a very modular way, so that single modules would be easily reproducible and future extensions would be easy to accomplish. Three interventions were already discussed when we were in Melusi; Adding more seating tyres, Extending the parkour with extra tyres, also adding a new height element by stacking them, and adding another table and bench to the Eiffel Tower seating structure. Ideally, the structure is an inspiration to similar organisations in other settlements, but also to the Melusi community.

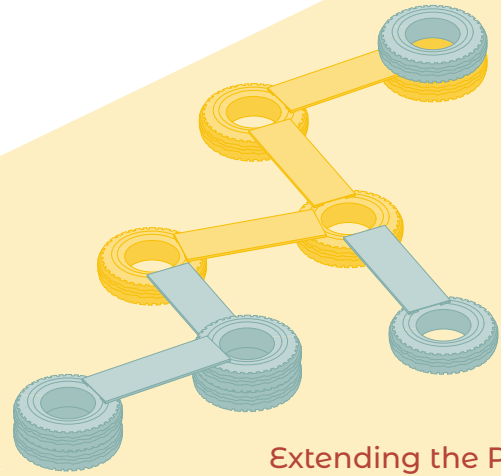

Extending the Parkour

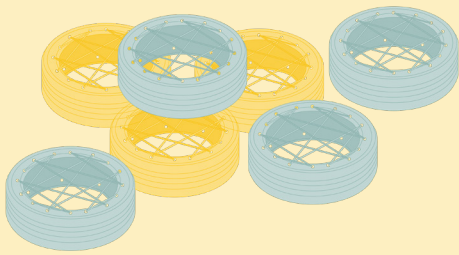

Adding more seating tyres

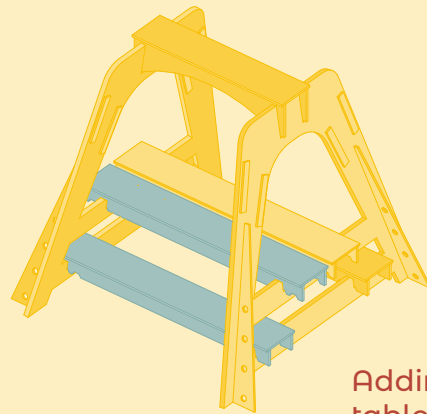

Adding another table and bench to Eiffel Tower

now



FUTURE

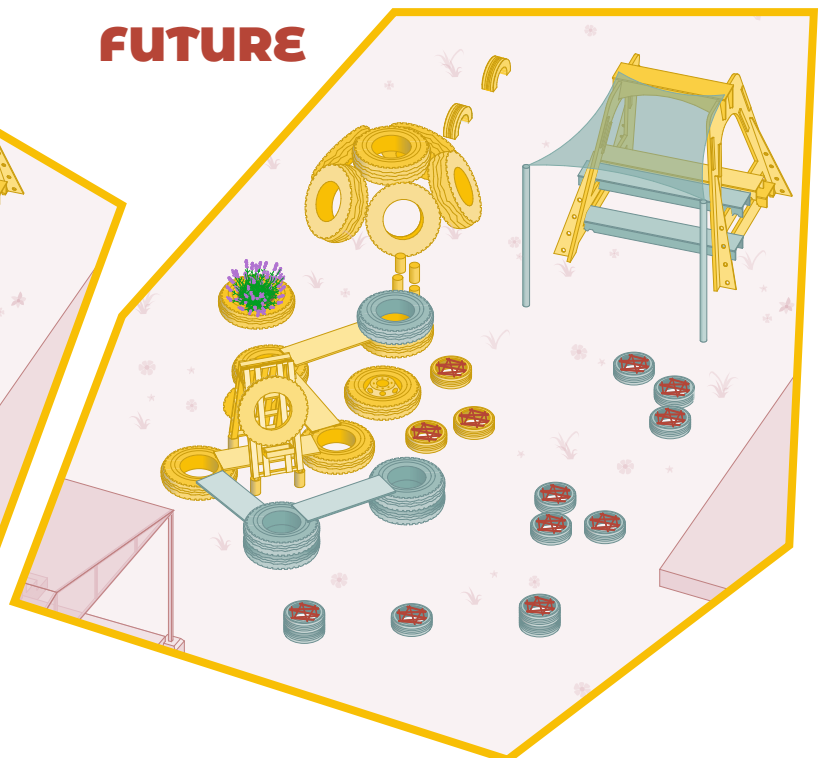

Personal reflections

Our takeaways

To reflect on our time in Melusi and South Africa is more challenging than we imagined. We had a great time in Pretoria and the surroundings, and were very happy with our project outcome and the process we took to arrive there.

South Africa in itself is a deeply unequal country, which is something you realise from the day you arrive. The proximity of wealth and poverty is so extreme, and sometimes experienced inside same day and these different contexts are sometimes hard to stomach.

We as a group take away so many learnings from the project work, with the following lessons being the knowledge we will cherish and build on.

The material is already there.

When we started material hunting, we did not expect to source very important parts of our project directly on site at MYDO. Especially when you work with a frugal approach, basing your design on what you find on site can make the process a lot easier. Using what you have in creative ways is a great way to create an affordable and reproducible project.

Relationships are not built in a day.

We wanted to include our stakeholders fully in our design and building phase. Especially in the design phase, we were lucky to experience a lot of trust from the MYDO team, which was based on a close and productive relationship in and outside of the project work. Getting to know each other, sharing meals and also doing activities outside of Melusi with the team really helped us to build a great relationship. Workshops are also a great way to listen and learn. They do not need to give you a tangible design or study outcome to be successful, the big strength of workshops is the time you can give to people to just express themselves in a safe space.

Knowledge comes from experience.

As we were a team of architecture students, we of course bring some knowledge to the context from our studies, but academic knowledge only gets you so far. In the design phase we had an abundance of great inputs from different members of the MYDO staff, all of them without an architecture or design education. Experiencing the context every day gives you an insight to what is doable, what would be appreciated by the kids and what material has worked with other projects in the past.

You have no idea.

In architecture, we are often very focused on spatial analysis from a far, two hour site visits and statistics. While all of these will give you insights, it still does not leave you with a full picture. Going to a context like Melusi taught all of us, that without experiencing it, we would have never been able to grasp the essence of the place. The people, the challenges and problems, but also everything that is great about Melusi. The community in the settlement is so close and happy to help. A lot of people you meet have a real drive to not only achieve great things for themselves, but also to help the community through their success.

THANK YOU

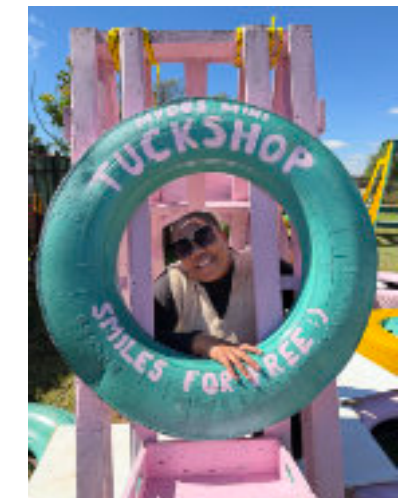
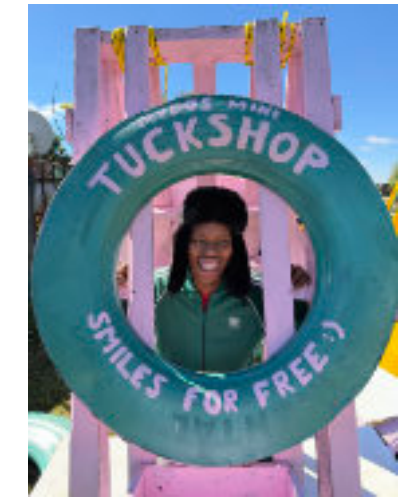

FOR EVERYTHING!

References

Architecture Sans Frontières UK (2014). *Change by design: Building communities through participatory design [Workshop report]*. <https://www.asf-uk.org/>

Ferguson, K. & Candy, S. (2014). *Participatory Design Handbook*. Co design Studio.

Malatji, H. (2026). *Malusi Youth Development Organisation*. [Presentation]. Held at MYDO Youth Center. Pretoria, South Africa.

Malusi Youth Development Organisation (2026). <https://www.mydo.org.za/>

Malusi Youth Development Organisation MYDO. *Home MYDOyouth*. Facebook. Retrieved April 2026, from <https://www.facebook.com/MYDOyouth/>

Moreno, E. (2026). *How to build childrens playgrounds from tyres*. Playgroundideas.org. <https://playgroundideas.org/how-to-build-childrens-playgrounds-from-used-tires/>

Oberholster, J. (2026) *Unit for Urban Citizenship. Innovating our tomorrow*. [Presentation]. Held online from Pretoria, South Africa.

Appendix 1

Us with the Playground

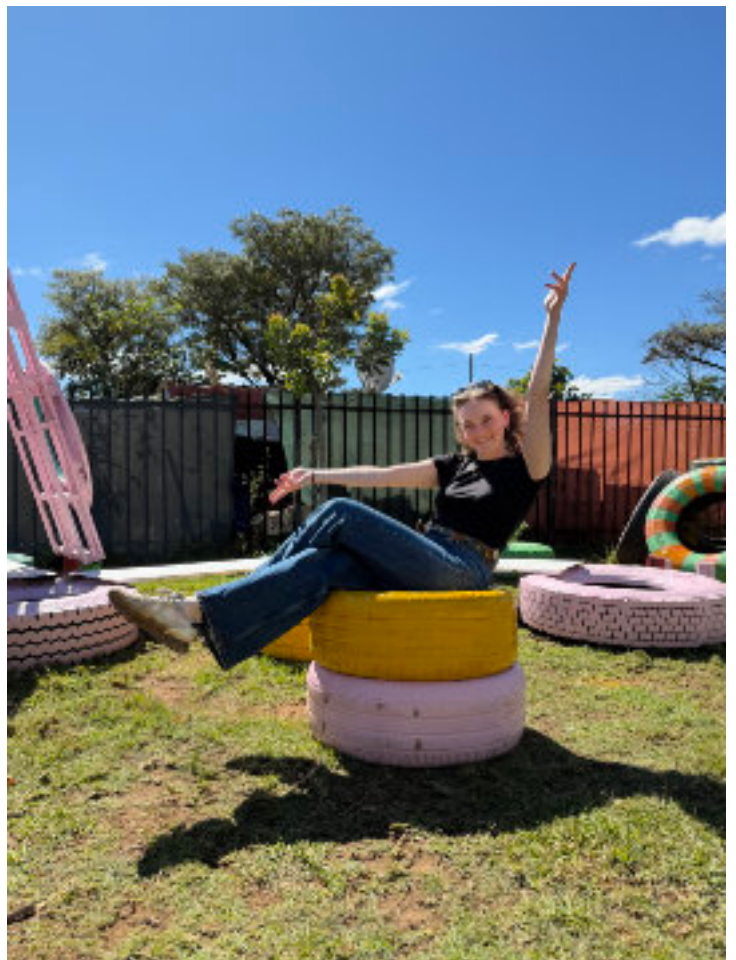

Appendix 2

Vibes pictures



Kids playing with the playground



View of the playground from MYDO's kitchen



Kids playing with the playground

Appendix 3

Relationship building

This are activities that we did outside the project to enjoy a good time with eachother



Zebra Hike



Hanging out after the workshop



Cheering for MYDO's Netball team



Having popcorn at the tuckshop



Having snacks the last day





Having dinner together

Appendix 4

Feedback Sheets

Evaluation Reality Studio 2026
MYDO Playground





The playground fits well into the space. 

The playground is safe. 

The playground fulfills the needs of children. 

The playground is easy to monitor. 

The playground will be easy to maintain. 

I am happy with the design and building process and felt included by the students. 

I am happy with the end result. 

Additional notes and comments:
I had a massive **FEEL** to work with you guys and I have learned how to manage
THANK YOU !!!

Evaluation Reality Studio 2026
MYDO Playground



The playground fits well into the space. 

The playground is safe. 

The playground fulfills the needs of children. 

The playground is easy to monitor. 

The playground will be easy to maintain. 

I am happy with the design and building process and felt included by the students. 

I am happy with the end result. 

Additional notes and comments:
I really want thank the team for the love and how they share us working with them. I felt so special & thankful to be part of the process.
THANK YOU !!!
You are welcome



Appendix 5

Building Process



Before the building phase



During the building phase



Finished Project

Appendix 6

Project Calendar

Banyana
Bafama

	MONDAY	TUESDAY	WEDNESDAY	THURSDAY	FRIDAY	SATURDAY	SUNDAY
Week 1							
Week 2		13 observation UP students	14 Workshop MPDO Staff	16 WORKSHOP WITH TEENAGERS	17 Embassy visit 10 ⁰⁰ -12 ⁰⁰	18 WORKSHOP WITH KIDS? "GAMES & SNACKS"	19
Week 3		20 DAY OFF	21 Material Research at MUSEUM	22 DESIGNING	24	25 SAFARI !! 😊	26
Week 4	27 HOLIDAY	28 CO-ORDINATE WORKSHOPS	29	30	1 HOLIDAY	2	3
Week 5	4	5	6	7	8	9	10

Pool Party !!

Botanical garden
Pizza night

Sterkfontein
Caves
Apartheid
Museum

Appendix 7

Inventory and Costs

Inventory:

Paid:

Cosave Powerbuild Hardware store	
Bio Fertilizer 5kg	27 R
Garden Soil 30l	88 R
2x Argyranthemum plant	118 R
2x Lavender plant	122 R
2x Paint roller	78 R
Paint brush pack	35 R
2x Nylon rope 10mm x 20m	138 R
Nails 50mm 200g pack	22 R
Screws pack	42 R
Africa Scrap Yard	
3x Metal sheet	150 R
TOTAL	820 R

Recycled materials:

MYDO

5x car tires

6x truck tires

2x truck tire walls

9x wooden poles d=15 cm, 60 cm

wooden tray

ca. 100l Soil

donated by Cosave Powerbuild Hardware store

5x Paint bucket 5l

2x wooden pallets

6x wooden plank 220 cm

2 wooden planks 120x15x8 cm

Appendix 8

Notes of Workshop 2

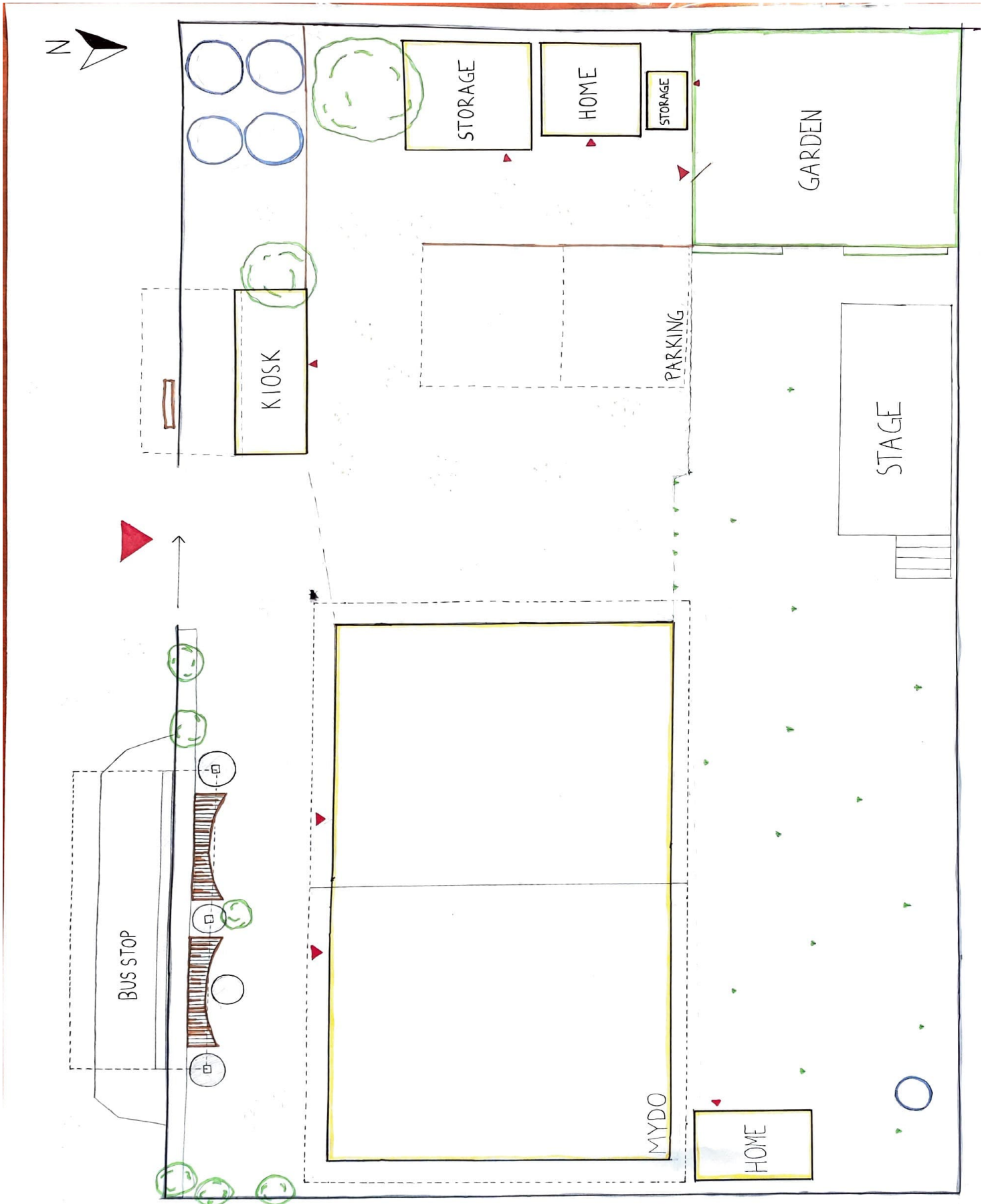

Before the workshop

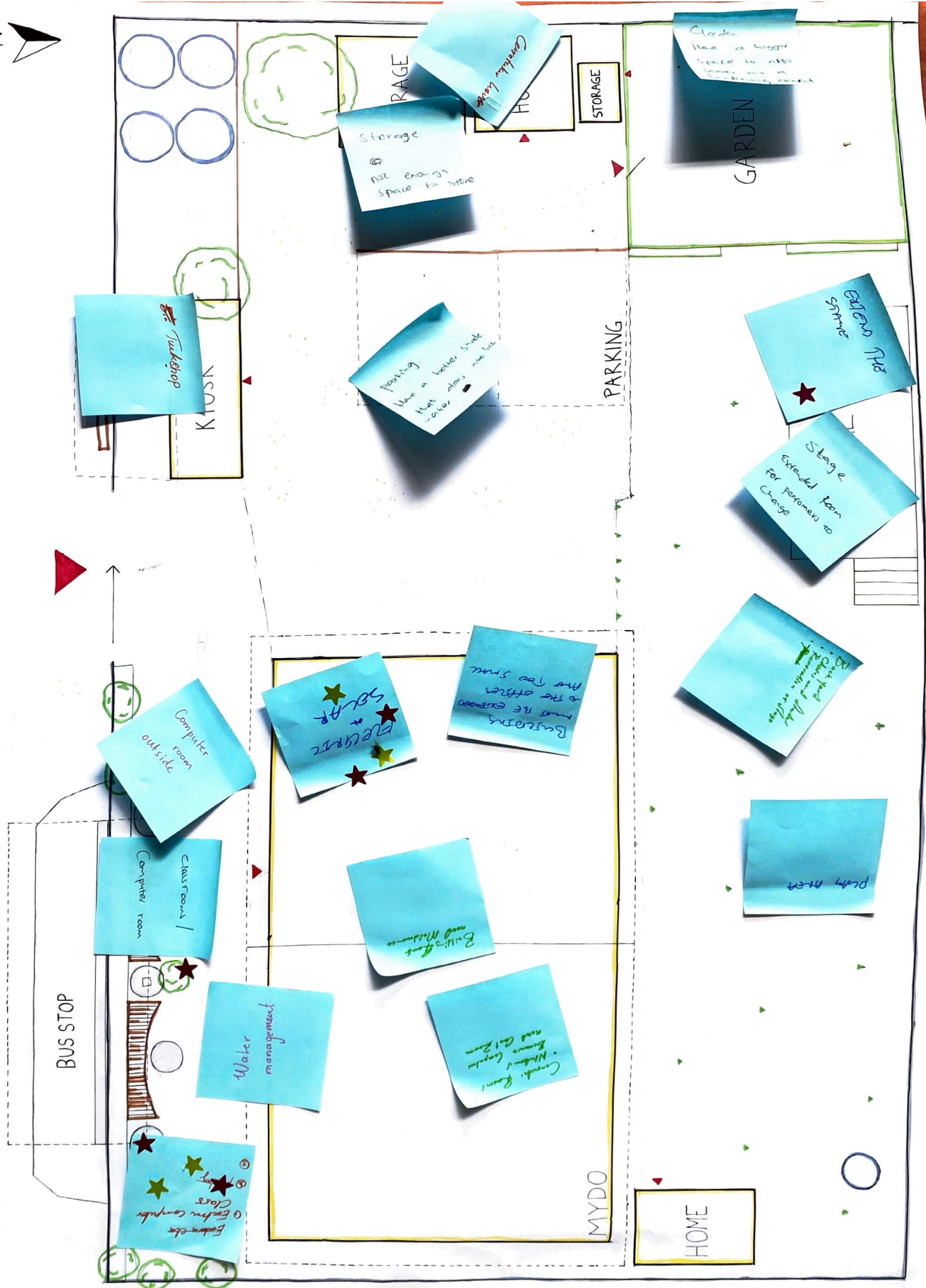

After the workshop

Staff workshop notes

16/4

meeting fire in front of tuck shop/entrance
↳ might be too small as they've grown

rain everyone's inside
↳ nets outside

events

↳ chairs

↳ electricity from windows to stage,
from kitchen or office window (Glady's)

↳ events once per season

Feb, June, Sept

other too, indoor, smaller, collabs

↳ check spelling

Dohanne, Thomson, Shane, Glady's
attending, Kijabo, Shaila

What is

(came later kitchen

Building

facilitator, teacher

↳ add containers in backyard to have
space for more classes

• Pavement

↳ muddy bc. of rain

↳ everywhere until the grass

- Backyard
 - ↳ put stuff to play with
 - ↳ good bc. grass
- Front side
 - ↳ announcements
- Garden
 - ↳ too small → enough for a week
 - ↳ minimizing costs
 - ↳ spruce 2 years ago

What could be

Dreaming

- Stage
 - ↳ changing room closeby to not have to go in MUDs
 - ↳ renovation
- Backyard
 - ↳ place to chill, seating area
- Computer room
 - ↳ too hot? not functioning well
- Roof leaking
 - ↳ office Makudi, conference room
 - ↳ too small and hot office

- Front area ← safer outside
 - ↳ expanded computer room container
 - ↳ ^{Double studios} one big there, less hot more air flow
 - ↳ many people want to do computer, can't have them all with the rooms they have → +15-20 people/container (3 month course)
 - ↳ old computers ⇒ proper computer lab!

- Tuck shop ~~for~~

- ↳ too small for the people working. cooking etc
- ↳ sometimes have to go outside → no space

- Next to Jaco's house

- ↳ a lot of stuff
- ↳ septic tank - sewer site

- Front area

- ↳ ~~the~~ rain water runs towards the house → issue

Appendix 9

Collage as a gift to the myDO team



PROJECT BOUNDARY DEFINITION (NAIL)

Project Name/Title:

Participatory design: Smiles for free

Team Members:

Baïka Fournier

Joshua David Hahn

Juliane Luise Freitag

Matilda Johansson Santana

Ingress: (Do this last)

MYDOs first playground shows how collaboration, trust, creativity and a bit of paint can improve children's equality, while making techniques accessible to the community. Our playground combines frugal design, local estatique and provides the kids with a place to dream that still feels close to home.

Project Background & Context

The project is set at the MYDO Youth Center in the Melusi neighborhood, in the city of Pretoria in South Africa. The center is located in an informal settlement area and is willing to expand its infrastructures in order to help more kids and improve the operating hours of the facility. We all chose to work with MYDO, the children and the youth, as that seems very rewarding. We all think that we could learn a lot from many different perspectives, from the youngest minds, still idealistic and full of dreams, to the most experienced adults with a firm grasp of reality. We think that working with this project will be challenging but will undoubtedly help us understand the culture and its people better. Overall, the project will give us the opportunity to work with a wide scale of stakeholders from very different age groups and experiences and a real view into the community in Melusi. Improving the day to day of the MYDO staff and the children is a highly rewarding framework for our project.

1. (N) Need Finding

1.1. Primary Stakeholder/User Groups

- MYDO, Melusi Youth Development Organization
- Managers of MYDO
- Volunteers working at MYDO
- Kids coming to learn at MYDO
- Parents
- University of Pretoria
- Melusi community

1.2. Guiding Questions

- What makes a good learning environment for kids between 6 and 12 years old ?
- How can the kids thrive with afterschool care and academic mentorship ?
- How can kids in settlements get access to recreational spaces?
- What would a good multi-purpose space where art, sport and culture programmes meet each other look like ?

- How can a space support kids in their imagination?

1.3. Needs

1.3.1.Expressed

- The Youth at Mydo need an outside space to learn interactively with nature. This space could take the form of an outdoor kiosk.
- The space behind MYDO should be sufficiently used as a play area.
- The existing seating structure is supposed to be moved and refurbished.

1.3.2.Latent

- MYDO might need more toys and diverse playing/ working areas for the different age groups
- MYDO might need structures for shade in the outside spaces
- MYDO might need a common garden area with some vegetation to help with the educational farming idea

2. (A) Aim & Methods

2.1. Aim (consists of 3 pieces; objective, purpose, result)

- *What is the overall objective(s), purpose(s) & result(s) of your project? (max 250 words)*

The main goal is to learn how to work together in participatory workshops in this multicultural space. We want to find out the needs and the purpose is to fulfill these with our result. We hope that the result will benefit MYDO and will encourage everyone there to keep improving and changing their space according to their own needs.

- *Overall Objective- what long-term societal benefit(s) will your project address (this may be larger than your specific project)*

We hope that our project can encourage more people to help MYDO to grow their space and improve their infrastructures in order for every kid in the area to get the opportunity to go there and benefit from the help the organization is offering. Our collaboration is supposed to give the children and youth in the settlement easy access to recreational spaces like a playground in order for them to have somewhere to use their imagination and spend their free time in a safe space.

- *Purpose- what/how will your project contribute to the overall objective*

Our project will give encouragement for future projects and fulfill the needs that we discovered. The playground improves MYDOs infrastructure and gives the organisation a further layer to provide the kids with a good experience, while taking the weight of entertaining the kids off the staff. As MYDO likes to hold events to improve visibility in and beyond the community, the playground provides another space for holding these events and acts as a representation of MYDOs values.

- *Results-What tangible results will your project produce/create to achieve the purpose and/or objective*

Our playground was well received by staff and kids alike. The playground combines imaginative playing with very simple structures and learning through the planting bed. The staff stated that our work inspired them to further improve the playing area at MYDO with frugal and simple solutions and the material already available on the MYDO site.

The playground will be used through events and hopefully provide a good representation beyond the community.

2.2 Methods & Design Criteria

In the process we used multiple methods and design principles to achieve true inclusion of all stakeholders. In the needs finding phase we did a walk-and-talk, to get to know the area and overall needs of MYDO, but also the whole community. We then had a needs-finding and dreaming workshop with the staff to find out specific areas of intervention. After defining the playground as our intervention, we held a drawing and dreaming workshop with the kids at MYDO, to get their input on how they imagine their perfect playground. Finally we held a co-design workshop with the MYDO staff, where we brought the design towards a buildable state. Here we brought a scale model of the design area and undefined material to give the staff freedom to imagine materials and building techniques.

2.3 Timeline

See appendix.

3 (I) Impact

3.1 Indicators

- The playground is regularly used by the kids and becomes a part of the daily process at MYDO.
- The playground is in usable shape in the coming years.
- The playground is expanded through interventions by the MYDO staff.
- The playground is used when events happen at MYDOs stage.

3.2 Sustainability goals (UNSDG, National, Local)

UN SDGs

3. Good health and well-being

The playground supports and encourages the kids in getting the necessary movement.

4. Quality education

The playground inspires the kids to play with their imagination. The urban gardening gives MYDO an opportunity to do gardening classes on a small and manageable scale.

10. Reduce inequalities

Children in the settlements do not necessarily have the same access to playgrounds and space to play in general. Providing this at MYDO gives them very easy access and a controlled and safe space to play.

11. Sustainable cities and communities

Making the playground modular, frugal and easily manageable provides the community with an easy source of inspiration to keep the playground functional and to expand it with recycled materials.

12. Responsible consumption and production

The playground is largely made from scrap material found at MYDO itself. There are no pieces specifically produced for the making of a playground and designed on the spot.

National and Local

The project is in line with the 2030 South Africa Development Plan and the City of Tshwane Regionalised Spatial Development Framework.

4 (L) Logical Framework Matrix (modified for Reality Studio)

See appendix.

4.1 Stakeholder Analysis Matrix

See appendix.

LOGICAL FRAMEWORK MATRIX (MODIFIED FOR REALITY STUDIO)

Project Name/Title: Smiles for free

Team Members: Baika Fournier, Matilda Johansson Santana, Juliane Freitag, Joshua David Hahn

- See the 'Guide to Logical framework' PDF for more clarifications. Attach to NAIL Draft.

	Project Description (Strategy of Intervention)	Performance Indicators <i>Indicators measure whether the objectives on each level are achieved</i>	Monitoring (Means of Verification)	Assumptions (Risk Assessment)
	<i>What the project intends to do (strategy of intervention)</i>		<i>Means of verification indicate where and in what form information on the achievement of objectives/indicators can be found</i>	<i>Assumptions are conditions which could affect the progress of the project but which are not under direct control of project management.</i>
Overall Objective	<p>The project is supposed to increase the quality of the outdoor spaces at MYDO Youth center in Melusi.</p> <p>The aim is to improve the childrens free time after their homework.</p> <p>The children in the settlement should have an equal access to recreational spaces.</p>	<p>Is the access to recreational spaces improved?</p> <p>Is the quality of outdoor spaces at MYDO improved?</p>	<p>Development reports of City of Tshwane and Pretoria</p> <p>Reports by MYDO</p>	
Project Purpose	<p>The project is supposed to increase the quality of the outdoor spaces at MYDO Youth center in Melusi.</p> <p>The space behind the primary building is currently not used to its full potential and should be upgraded.</p> <p>While the garden space is used by the kids for playing, a supporting structure like a playground would improve usability and relevance for MYDO and improve the day-to-day for the MYDO staff.</p>	<p>The space behind the building is used for more time by the kids.</p> <p>The MYDO staff has to spend less time on entertaining the kids.</p>	<p>Reports by MYDO</p> <p>Feedback by the MYDO staff</p>	<p>Access to waste water tank and other accesses have to be kept even with future additions to the structure.</p>

<p>Results (Outputs)</p>	<p>Introduction of a Parkour-Playground structure made from re-used materials, including seating made from tires, a roof and tuck shop structure from palettes and jumping poles.</p> <p>Refurbishment and relocation of big seating structure.</p> <p>Refurbishment and painting of the existing tire structure and inclusion in overall concept.</p> <p>Fixing the background of the stage and making it more future proof.</p>	<p>Plans for reproduction and extension are in place already.</p> <p>Our project inspires the MYDO team and other student teams working on site.</p>	<p>Feedback sheets of the MYDO staff</p> <p>Communication with MYDO staff after project completion</p>	<p>Sufficient interest and time of supervision have to be provided by the MYDO staff.</p> <p>As the structure is a partly wooden structure, repairs will be needed in the future in order to keep the structure functional.</p> <p>The structure does not define the way of playing on it, to evoke imagination, but there is the risk of unforeseeable uses which could be unsafe.</p>
<p>Activities</p>	<p>Our project very directly influences the funding opportunities of MYDO, as it further formalizes the Youth center. The project can be extended with little funds.</p> <p>Knowledge from our Handbook has to be transferred to the community to have an impact.</p>	<p>Resources (means)</p> <p>Material: string, screws and nails, paint, textile, cable ties, plants</p> <p>Recycled: wood, tires, metal sheets, palettes, soil</p> <p>Tools: Saw, Screwdriver, Brushes, Sanding device, Drill, Knife, Hammer</p> <p>Parts of the project require power tools, for most parts they are not necessary. As the structure is modular, whole parts are not dependent on power tools and can be done with very simple tools.</p>	<p>Costs</p> <p>Material cost: 820 R / 475 SEK</p>	<p>No indication if the community in Melusi will put value to the ideas we brought or if they have sufficient time and resources to reproduce it.</p>

Appendix 11

Model Pictures

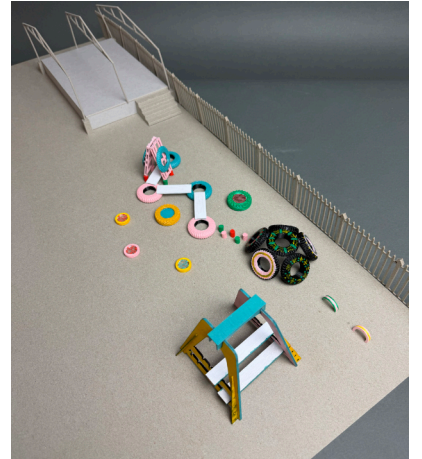
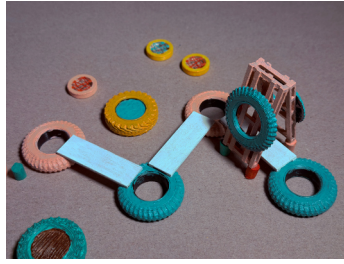
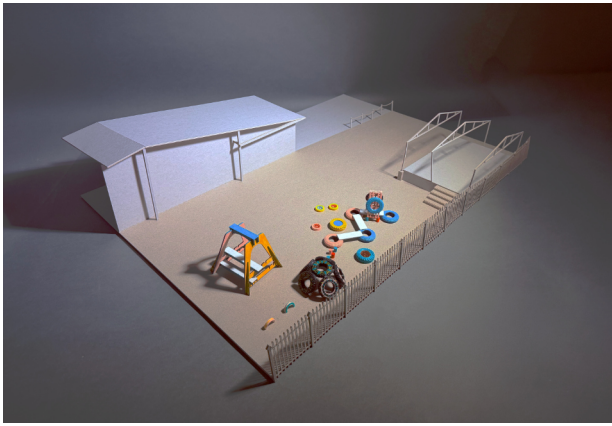

Appendix 12

The Building Handbook

The following pages Show our Building Handbook for the playground and possible extensions. It is a step by step guide for every intervention we did. This Handbook will be sent to the MYDO organisation.



HANDBOOK

SMILES FOR FREE

MYDO'S PLAYGROUND

CONTENT TABLE

The Eiffeltower	1
The mini Tuckshop	5
The Parcour	9
The tyre seats	13
The tyre plant	15

THE EIFFELTOWER

What you need:

- Wood
- Paint
- Paint brushes
- Paint roles

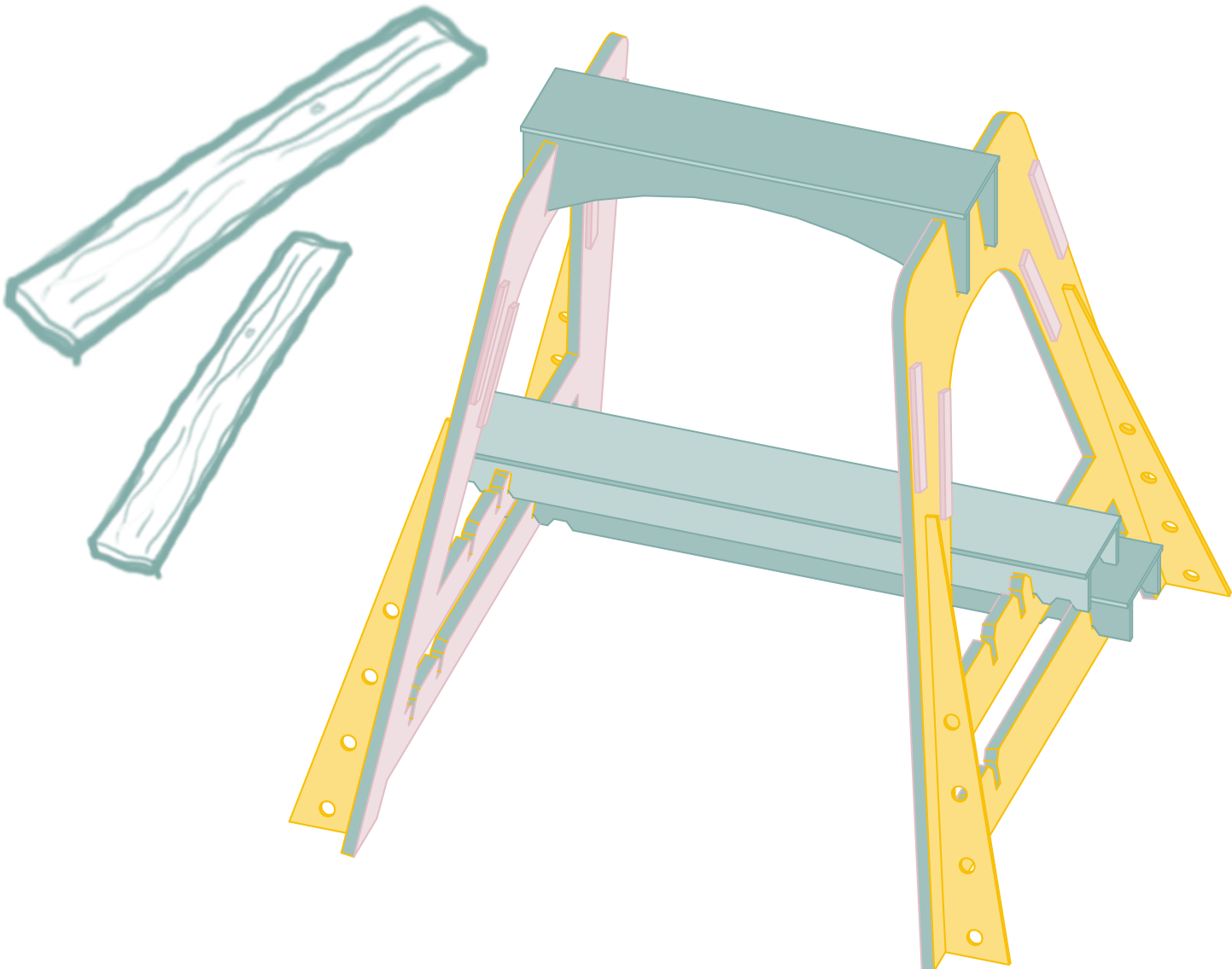

How to build

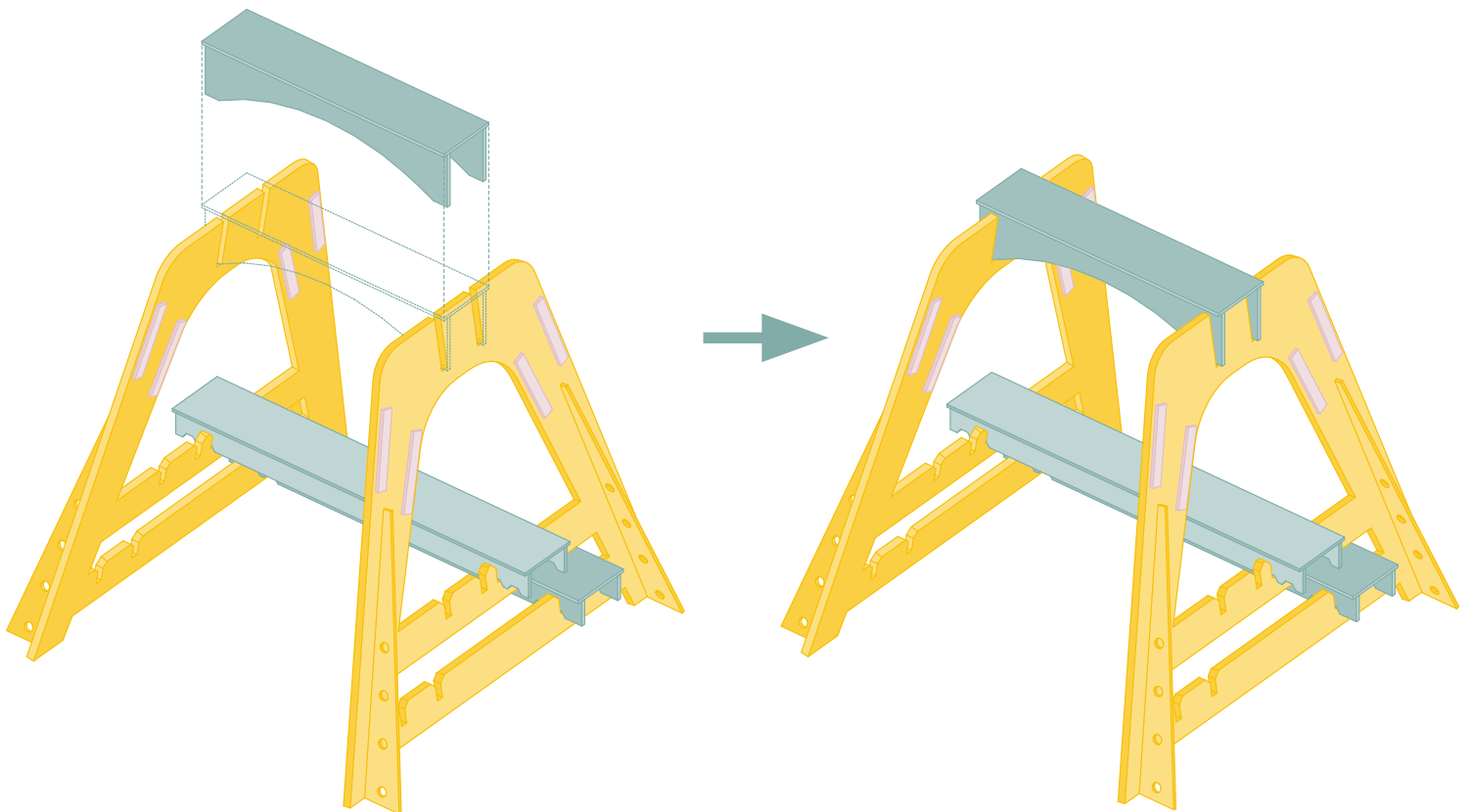
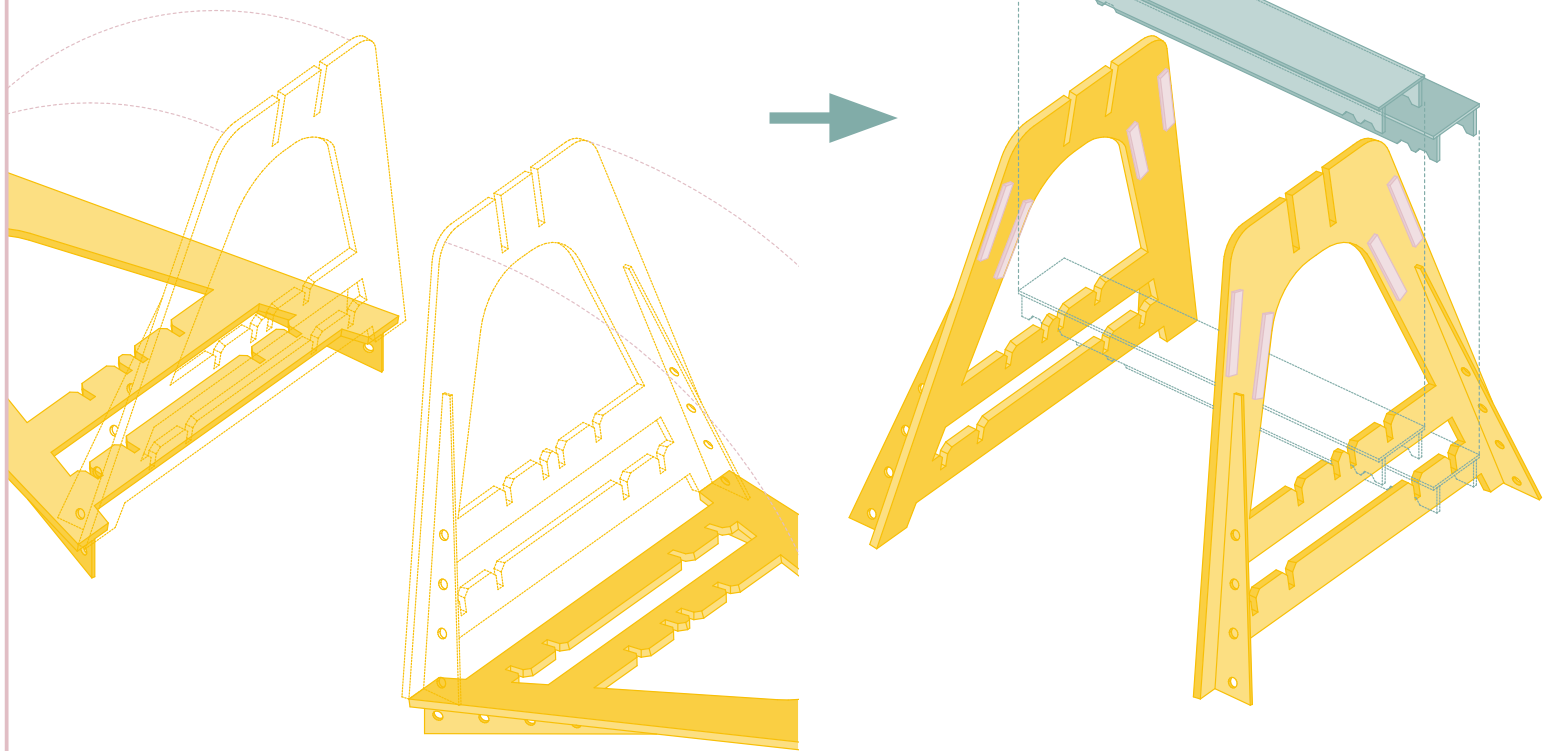

How to scale up

The Eiffel Tower can easily be scaled up by adding a bench and a table to the structure. The wood required for this is already on the MYDO site. If the beams are not long enough, they can be joined together as shown in the drawing.

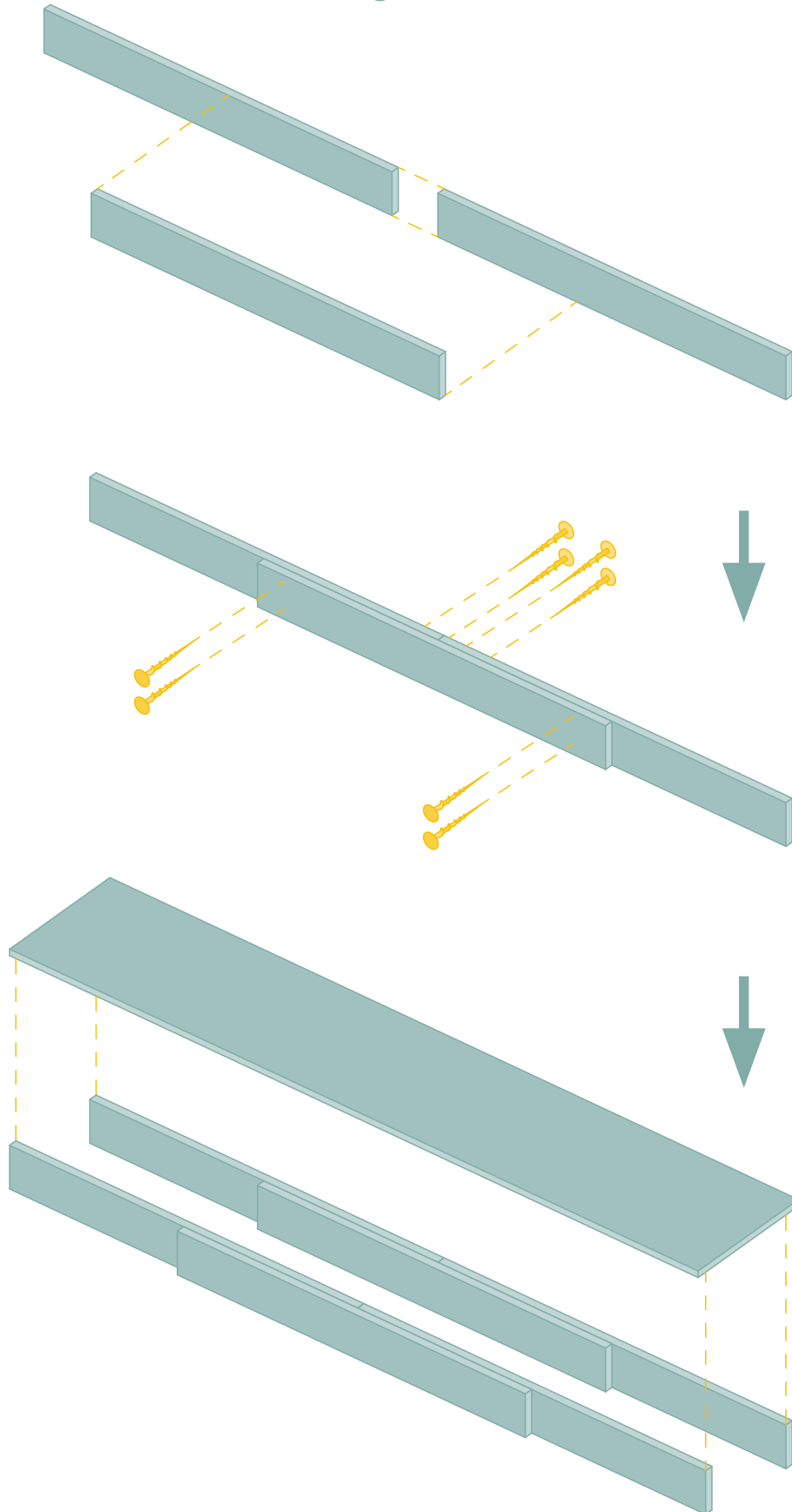

The Eiffel Tower has fittings that allow an extra table and an extra bench to be attached. Beams can be placed in two slots in the wood on each side. A panel can then be placed on top of these to serve as a table or bench. The wood required for this is already on the MYDO site. If the beams are not long enough, they can be joined together as shown in the drawing.



THE MINI TUCKSHOP

What you need:

- Wood pallets
- Paint
- Wooden box
- Screws or bolts
- Cut-up tyres
- Round wood

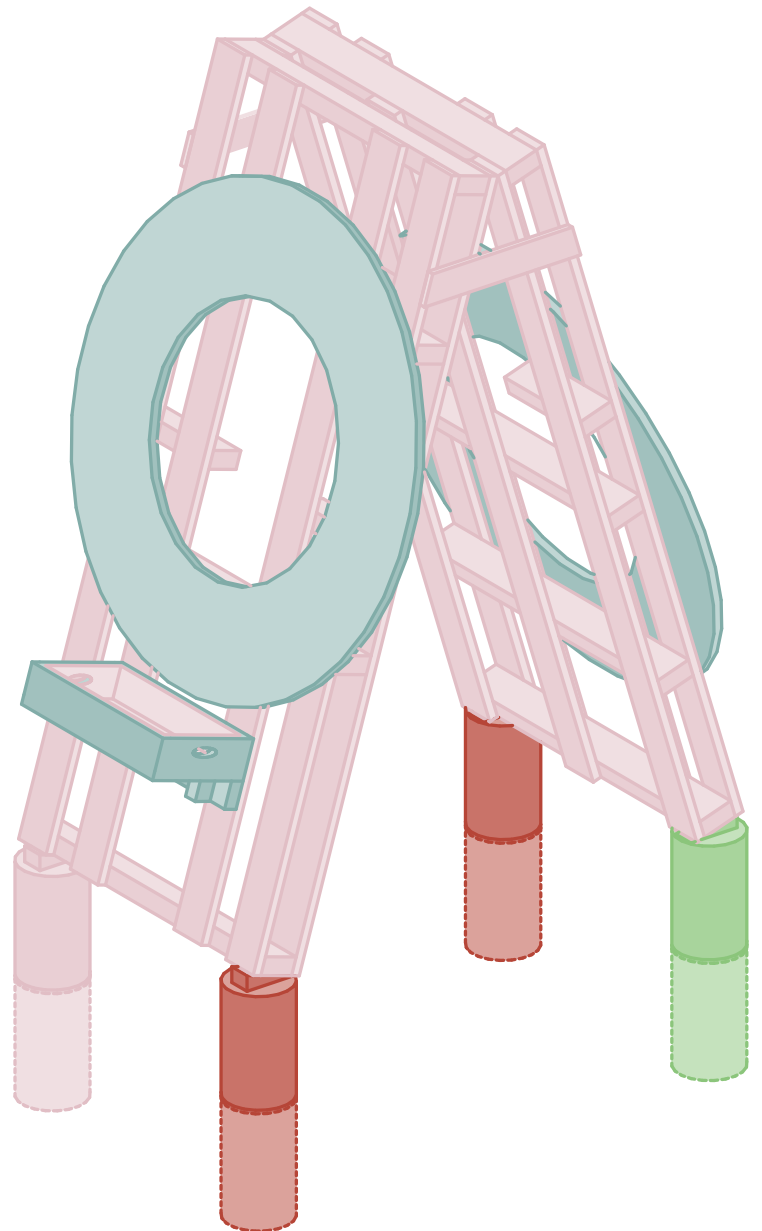
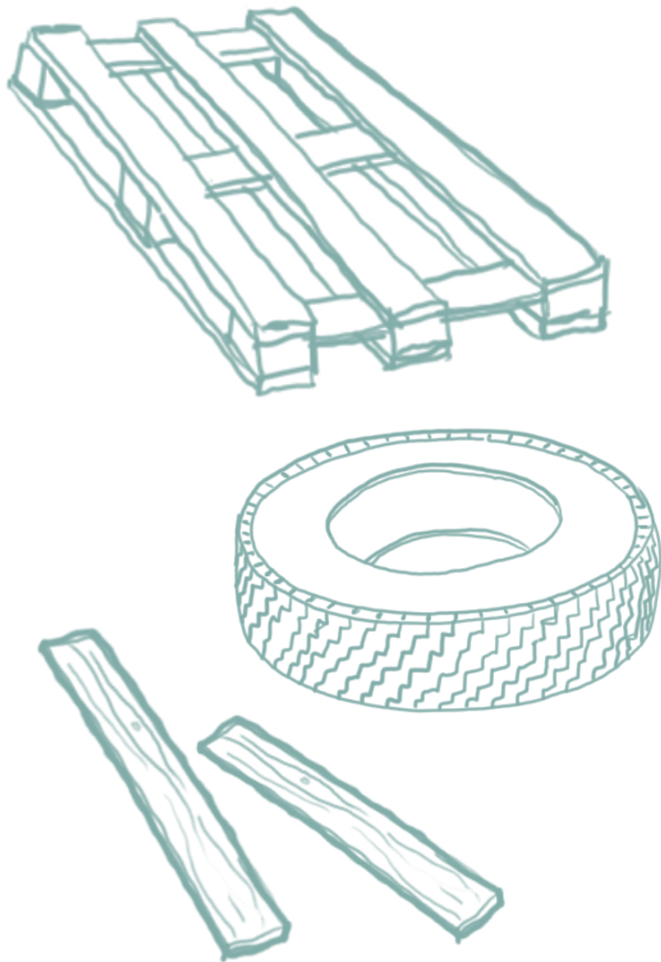

How to build

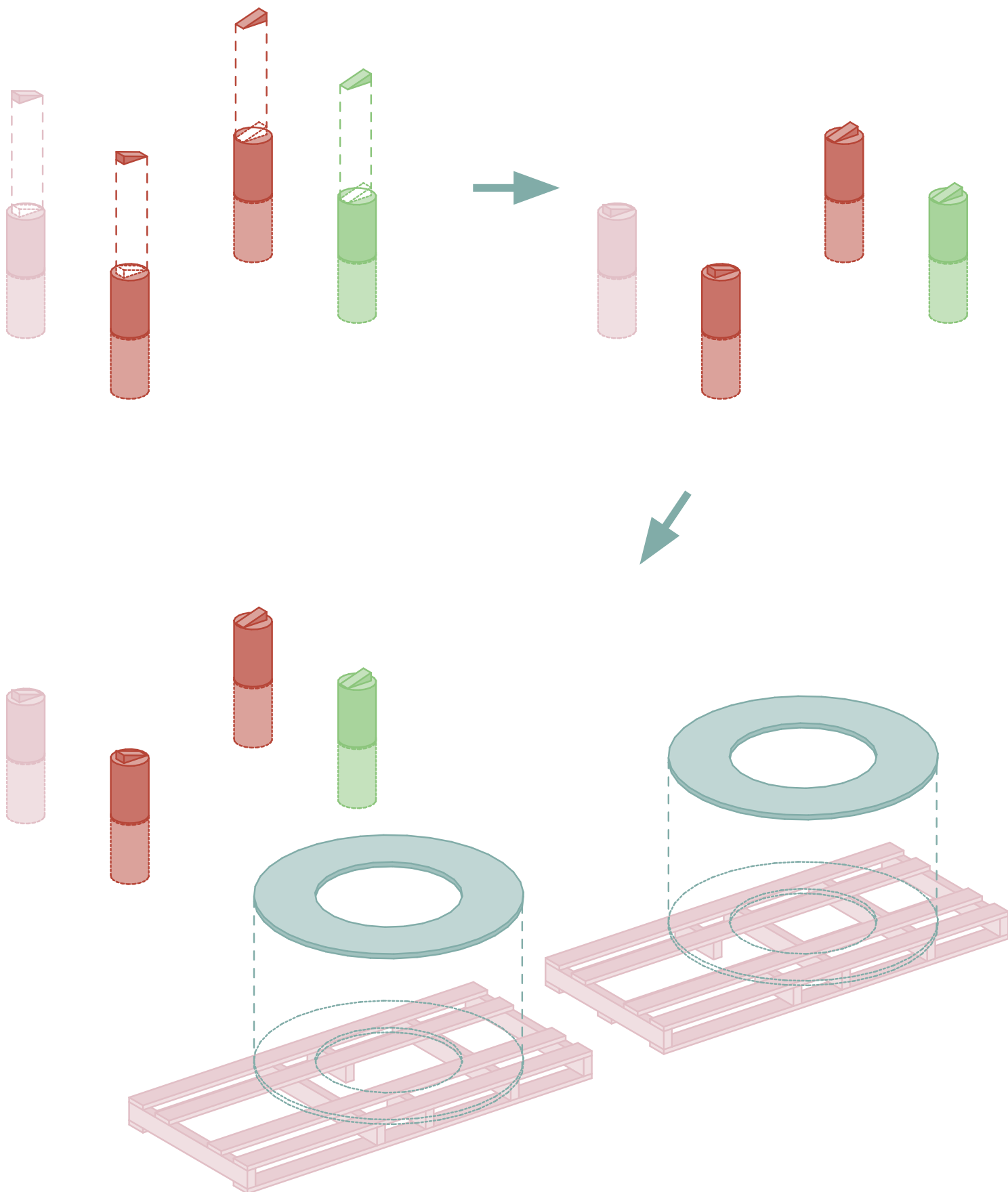

THE PARKOUR

What you need:

- Wood panels
- Metal sheets or similar
- Paint
- Truck tyres
- Screws or bolts

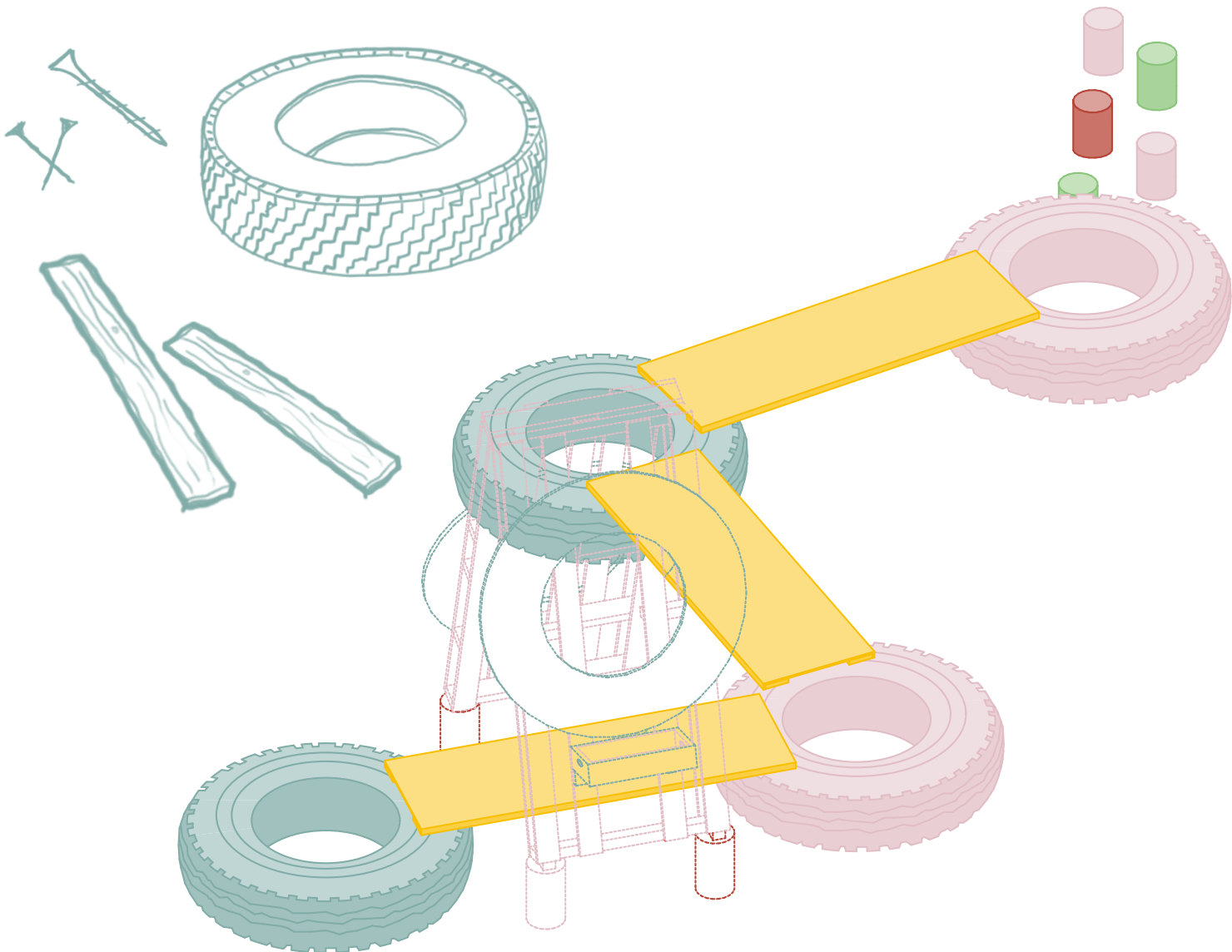

How to build

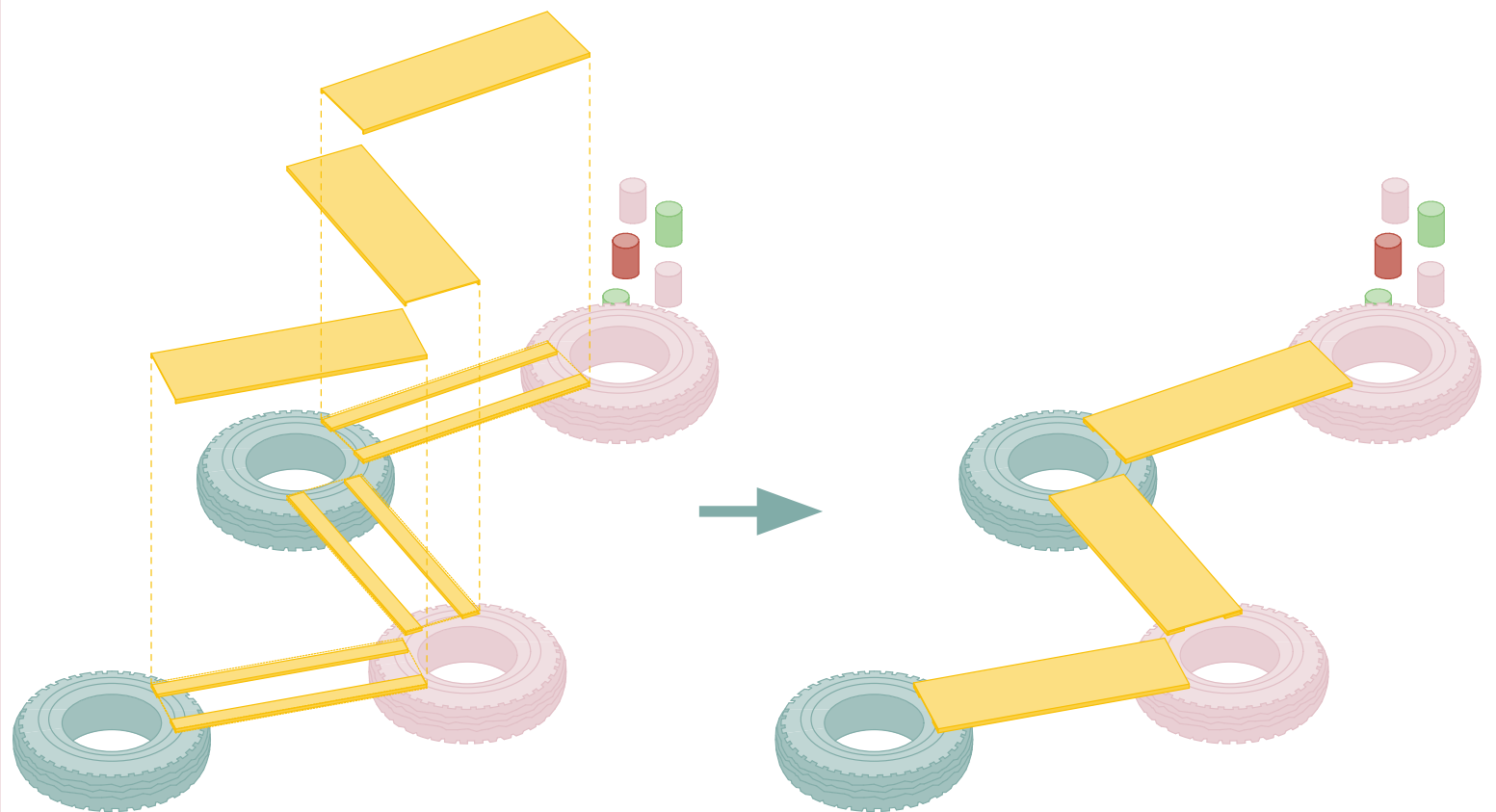
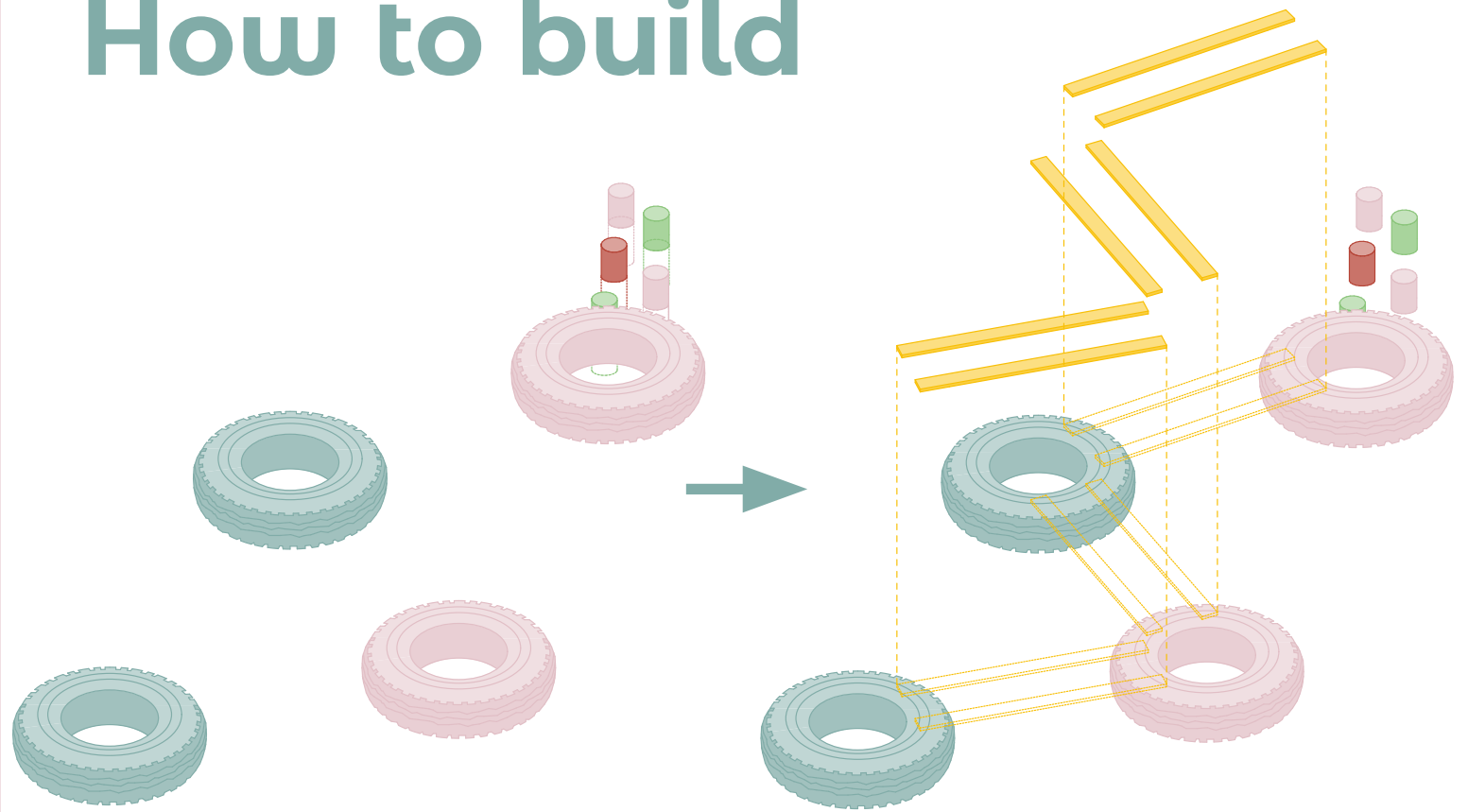

How to scale up

Attaching the wood to the tyres requires only some wood and screws or bolts (bolts with nuts last longer). The wood is then screwed onto the tyres as shown in the sketch below.

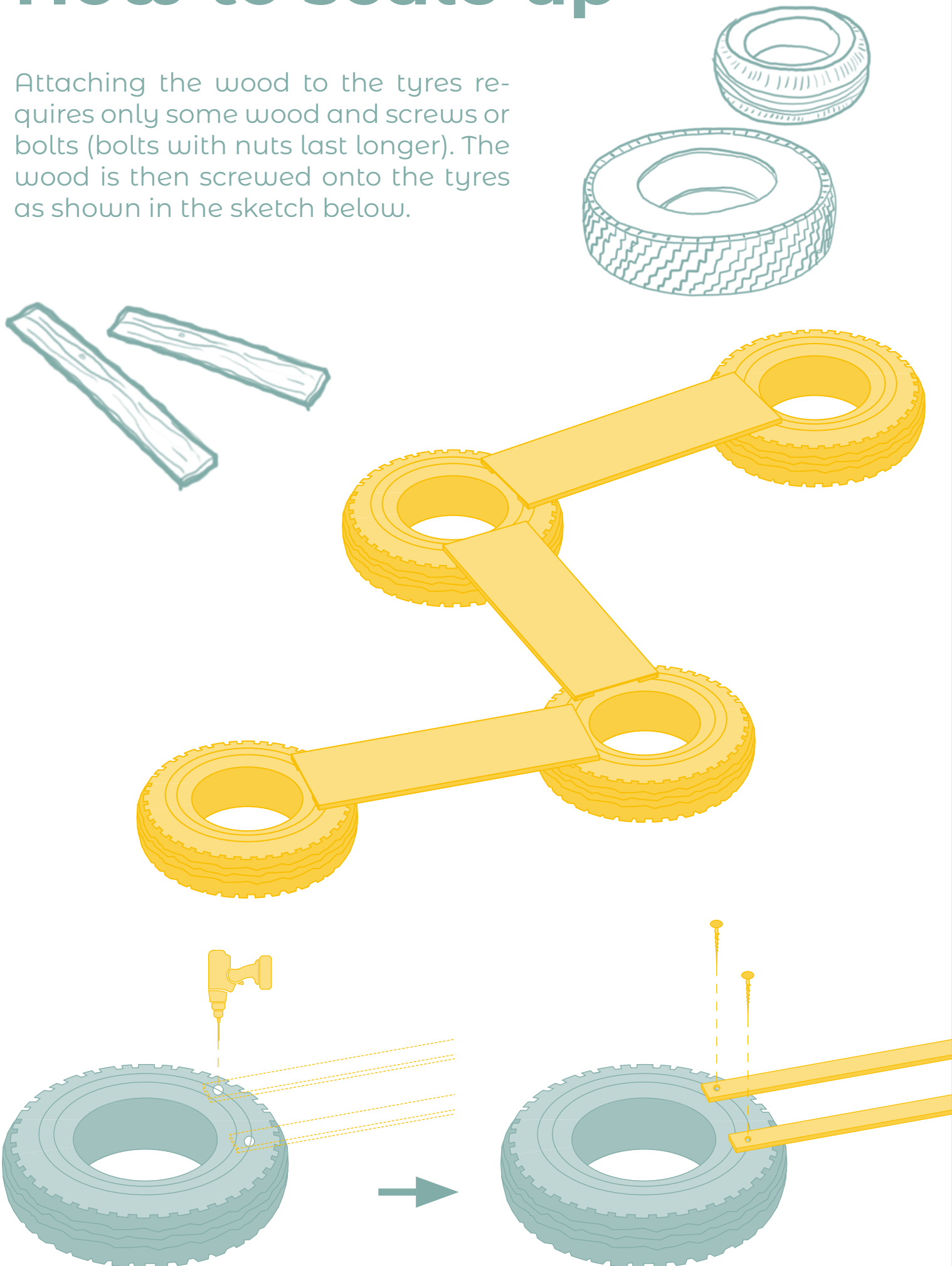

The parkour course can easily be extended and scaled up in various directions. Additional bridges can be added. You can also stack several tyres on top of one another to create a higher bridge. This could then even be used as a table or a place to sit. Below you can see an example configuration.

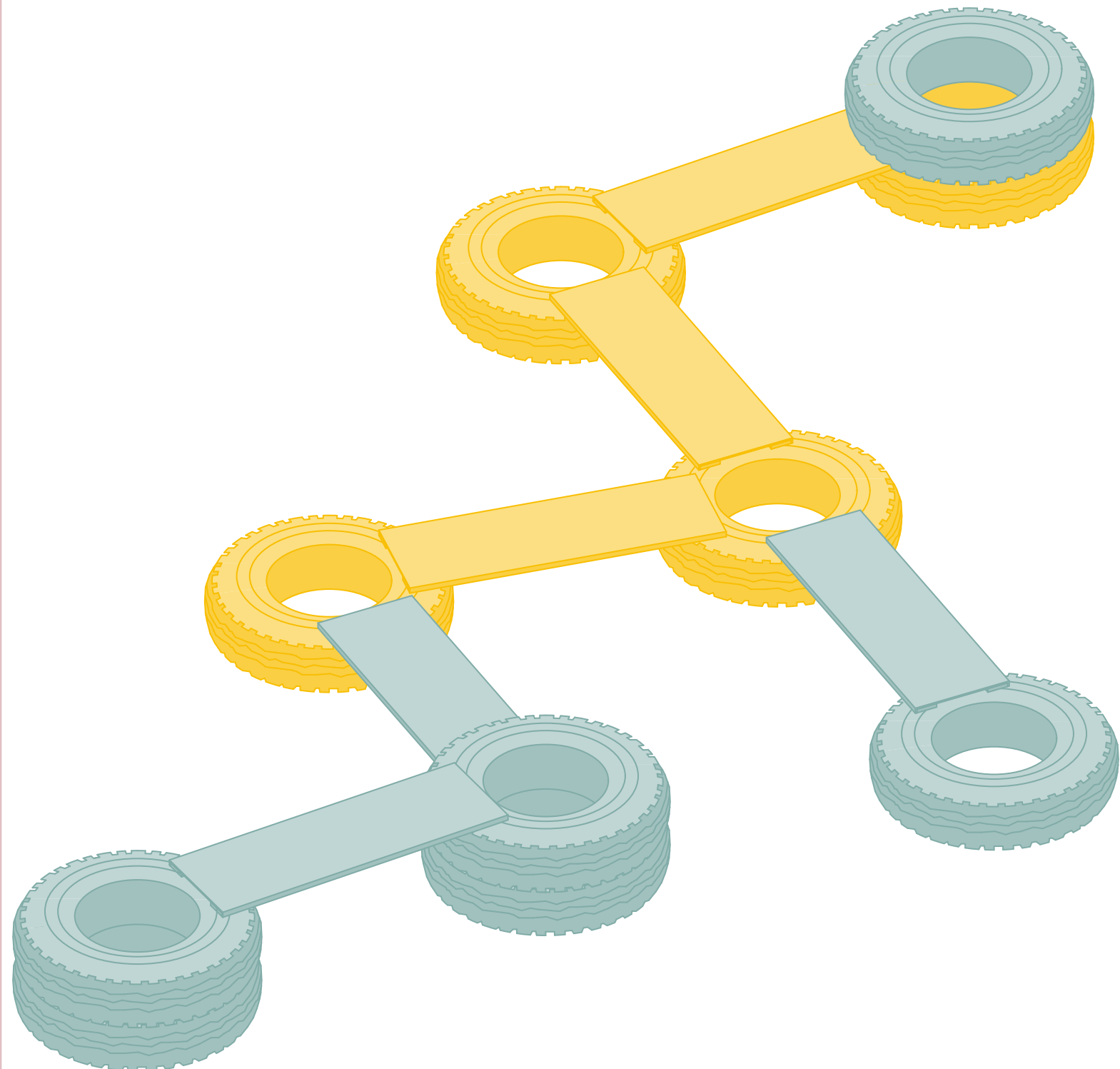

THE TYRE SEATS

What you need:

- Car tyres
- Paint
- Paint brushes
- Rope

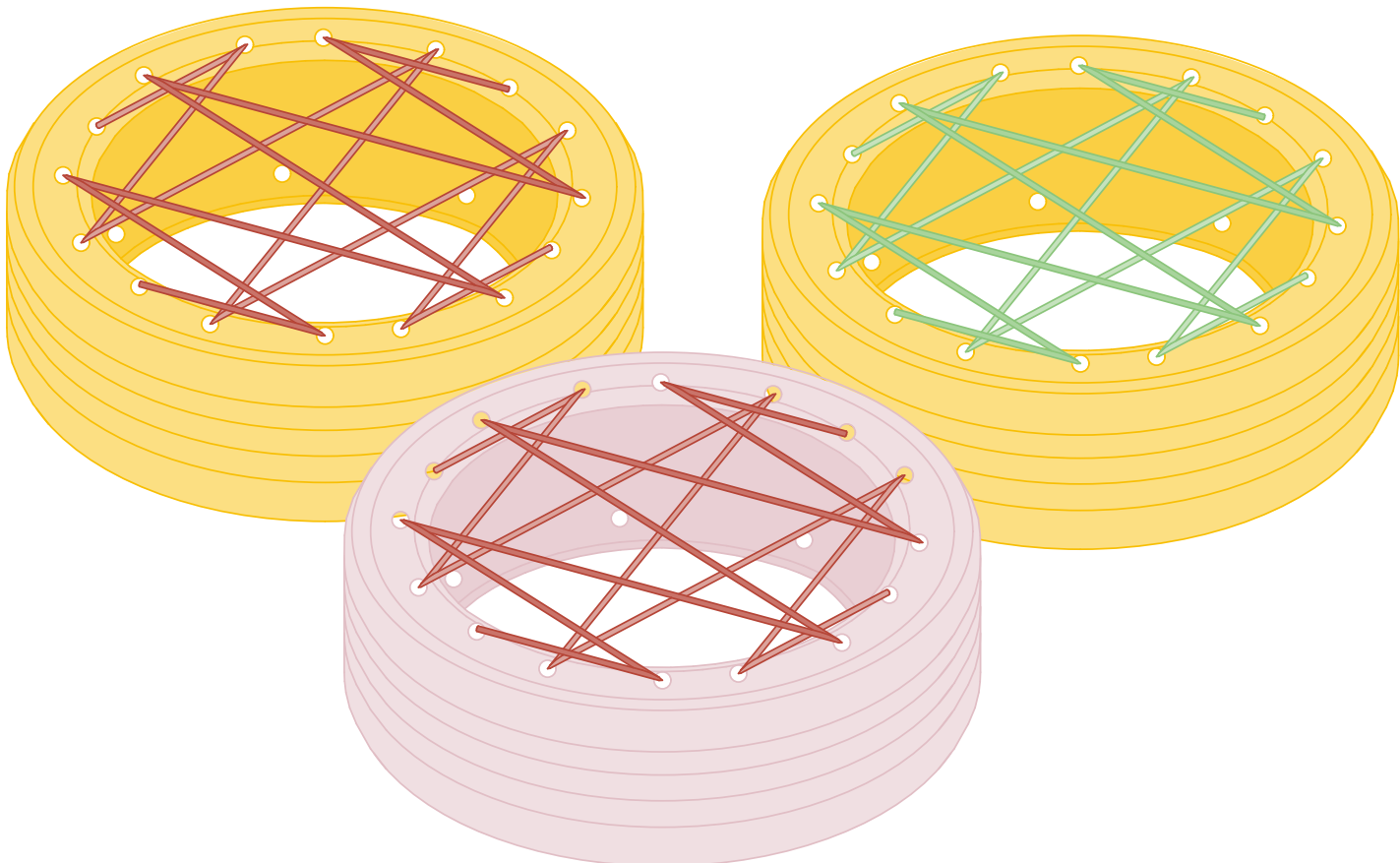
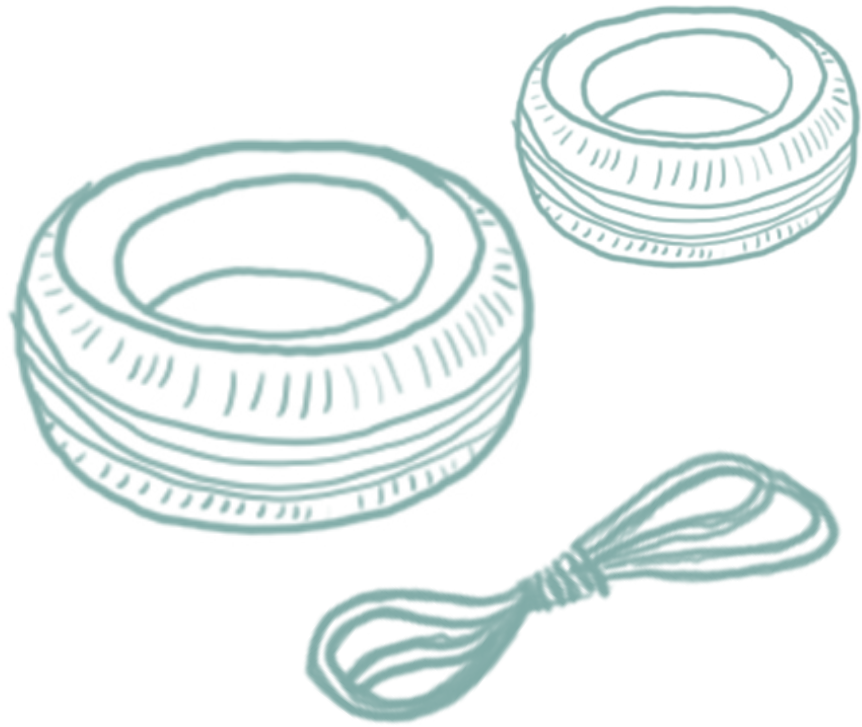

How to build

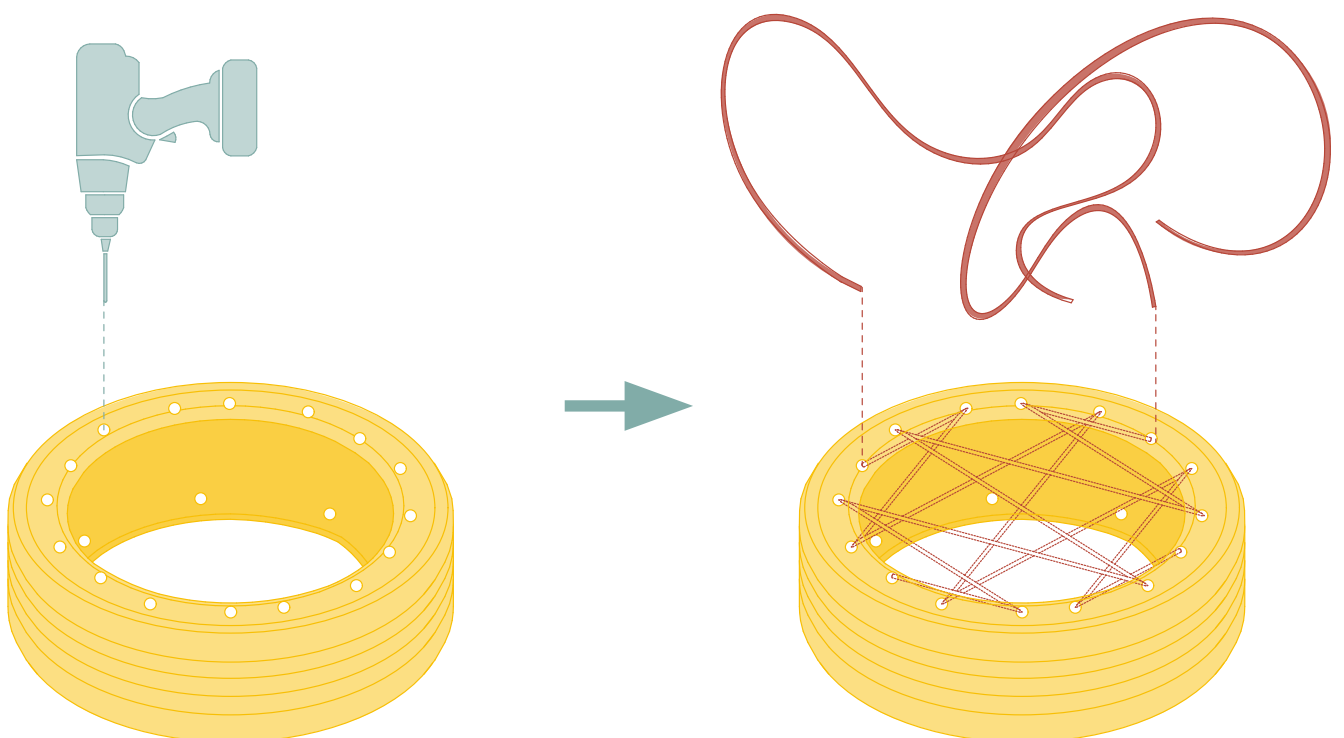
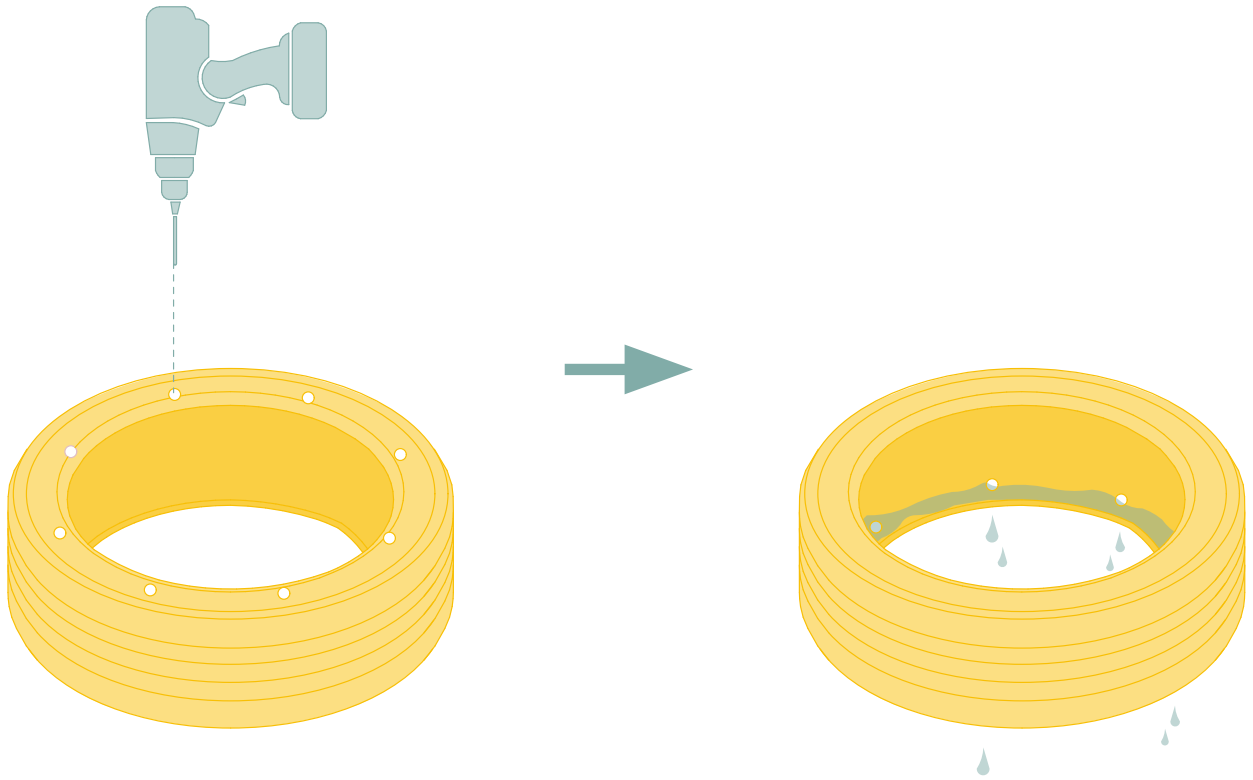

THE TYRE PLANT

What you need:

- Truck tyres
- Soil
- Fertilizer
- Plant

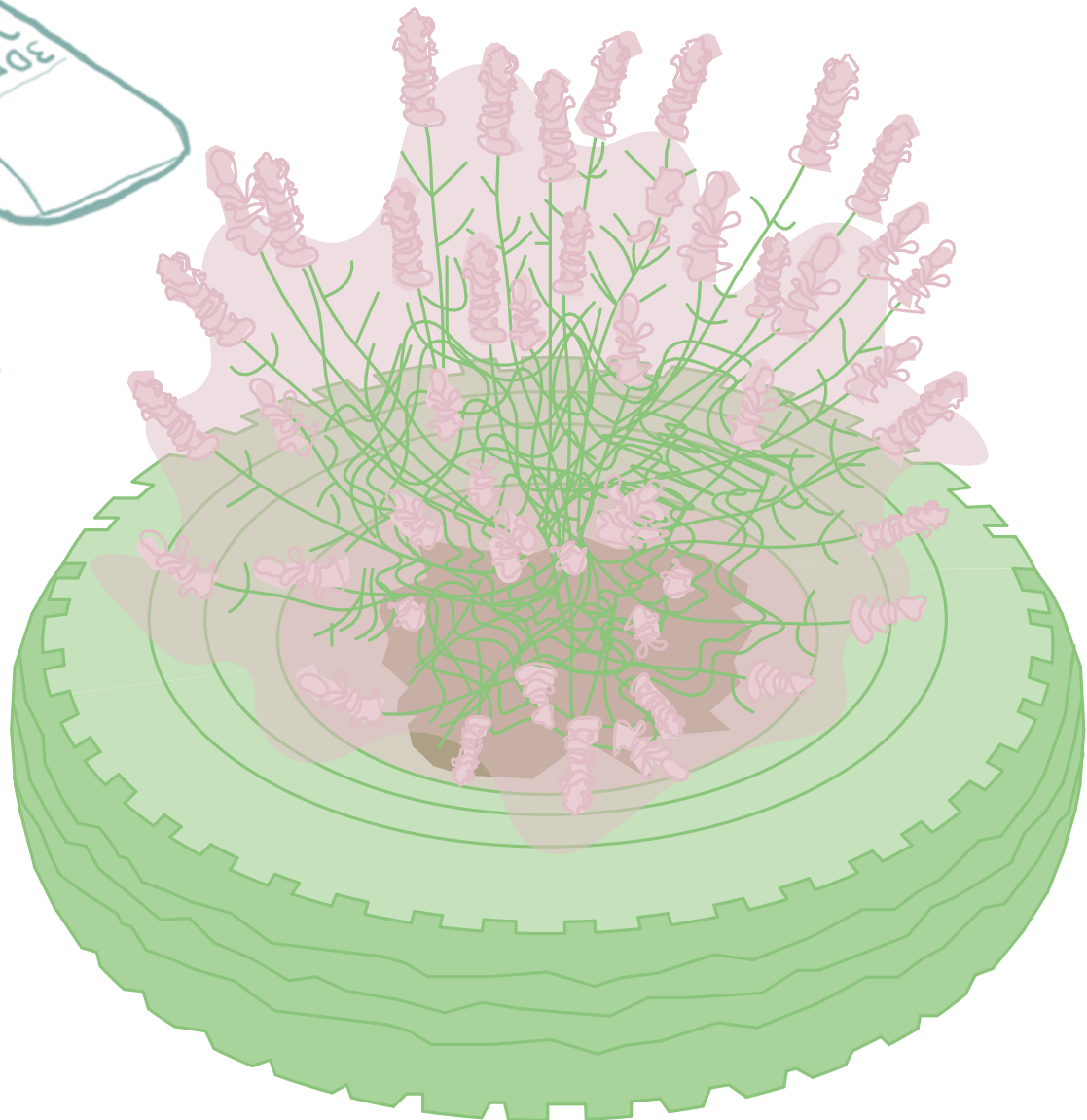
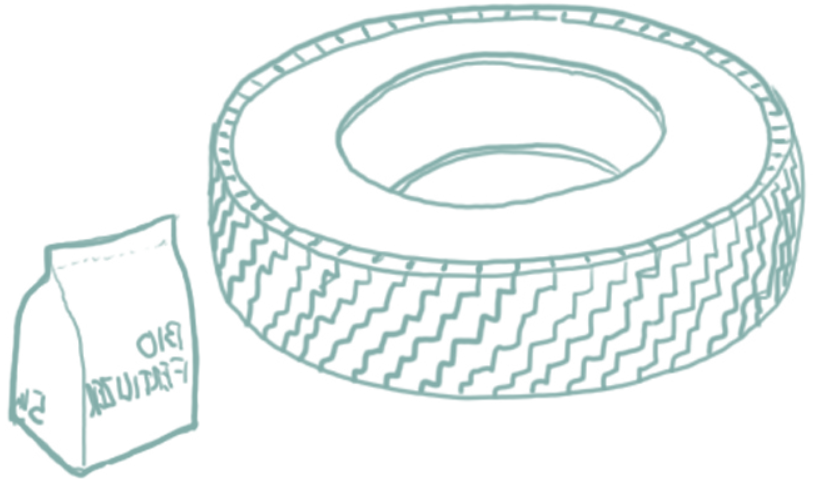

How to build

