

A CIRCULAR HOME



- Investigating tools for resilient architecture -

Sandra Richardson

*Chalmers School of Architecture
Department of Architecture & Civil Engineering
2024*

*Examinor: Mikael Ekegren
Supervisor: Björn Gross*



A CIRCULAR HOME
By Sandra Richardson
Spring 2024

Chalmers School of Architecture
Department of Architecture & Civil Engineering

Master's Programme of Architecture and Urban Design
Building design and transformation

Examinor: Mikael Ekegren
Supervisor: Björn Gross

ABSTRACT

Our society has urgent challenges with water supply, food production and electricity availability, due to environmental issues and wars. Architects can contribute more conscious to all these fields by letting our architectural tools be based on nature's resources and its conditions. By considering one of the main tasks of architecture, keeping us warm, already in the sketch phase the buildings get less dependent on mechanical systems, and by seeing water and food more as circular systems our architecture becomes more resilient.

To get background knowledge, literature and built references was studied. The knowledge was then translated to design strategies, to act as a toolbox in the design phase. As a complement to the design strategies, references have been studied and a building program was created, that also inspires and imposes demands on the building. The result is a prototype house for one family, which in this case was tested on a plot outside Gothenburg. A detailed sun study was carried out for the site as it impacts several design principles.

In the proposal, rooms are placed according to the time of day they are used and temperature requirements for each room in relation to the sun movement. The common spaces are allowed to expand and shrink while need and season changes, further the user can experience different zones within the home, ranging from colder rooms to different greenhouse zones, thus blurring the boundaries between outside and inside. The house is designed with solid materials such as wood and brick, and through its thoughtful placement, they contribute to the heating of the house as well as the architectural expression. The tricky part is to do pre-calculation of how it impacts the indoor climate when trusting nature.

If there were more time, an investigation of putting several units together would have been interesting. The tools can be implemented on a larger scale than a single-family house, thus contribute to a more sustainable construction sector with resilient architecture.

Key words: Climatic architecture, design tools, crisis preparedness

STUDENT BACKGROUND



- 2023- **MSc, Architecture & Urban Design**
Local context, 15 credits
Chalmers University of technology
- spring 2023 **Livscykelanalys för samhällsbyggare**
5 credits, Borås Högskola
- fall 2022 **Internship**
Norconsult AB
- 2021- 2022 **MSc, Architecture & Urban Design**
Residential healthcare, 22,5 credits
Housing inventions, 22,5 credits
Nordic Architecture, 4,5 credits
Dealing with inequalities, 3 credits
Chalmers University of technology
- 2018- 2021 **Bachelor in Architecture**
Chalmers University of technology

TABLE OF CONTENT

INTRODUCTION 6

Problem statement
Aim & purpose
Research question
Delimitations & assumptions
Method

BACKGROUND 10

Bottom-up projects
Traditional buildings
Passive house
Nature house
Nudging
Consequenses of smart homes
Detached houses as typology

DESIGN STRATERGIES 20

Temperature regulation
Floorplan design
Geothermal heat
Water & sewage
Use of resources

REFERENCES 32

Ankis naturhus
Villa Idun-Lee
Program comparison

DESIGN PROPOSAL 38

Building program
The site
Sun study
Floorplans
Facades
Section
Details

DISCUSSION 58

The process
The proposal
Conclusion

BIBLIOGRAPHY 68

Literature
Built references
Pictures, Figures & Tables

INTRODUCTION

” *As architects and planners we work daily with visions and projects that should be sustainable, but the result often contribute to the opposite.*“

(own translation of Hagelberg, Henriksson, & Lindberg, 2022)

PROBLEM STATEMENT

The life we, architects, design for often relies on already set patterns, and they are usually resource intense. The latest rapport from IPCC announced the environmental situation as urgent (Hagelberg, Henriksson, & Lindberg, 2022). The construction sector was during 2019 responsible for 38 % of CO2 emissions. 1/4 of this is from the production of materials together with the building process and 3/4 is from operating the building, mainly heating and cooling (Rahm, 2023). Since 31st of December 2020 all new buildings done in EU should be close to zero energy building to make sure energy is used in a more efficient way (Linton, 2020). Still, one of the main tasks for architecture is to keep us warm, to maintain the human body temperature constantly at 37 degrees (Rahm, 2023).

During the winter 2022 Swedish authorities described the energy situation in the country and rest of Europe as forced. Sweden do have a surplus of energy, seen to the whole year, but during the coldest part, when we consume most, we do not have enough. At the same time, it is harder to import from Europe as they also lack energy due to the situation with Russia and Ukraine

(Krisinformation, 2023). Russia is one of the worlds' biggest producers of oil, gas and artificial fertilizer that EU was dependent on. Besides that, the Russian war against Ukraine has also caused issues with food production, as Ukraine is one of the worlds' best places for farming. This have made us aware of the vulnerability in our society. In a historic perspective when crises like this arise, we tend to aim for a piece of land, instead of having large monetary assets. This to be able to provide ourselves with food and clean water, such things that we have been taken for granted for decades but now the fear of lacking this is realistic. This is most likely also contributing to the trend of more people moving out from cities compared to before the Covid-19 pandemic (Hagelberg, Henriksson, & Lindberg, 2022).

The energy crisis has made the electricity price increase dramatically. Measurements by the authority shows decreasing consumption as many have evaluated their needs, but studies also show that we produce less energy than a few years ago. Lack of energy can lead to a need for planned disconnection for some areas to prioritize businesses

especially important for society as hospitals, telecommunication operators, internet service providers etc. Generally everything in our society needs electricity, so to avoid disconnection it is necessary. This is done by decreasing our demand for electricity. What usually consume most electricity in our homes is heating and the production of hot water (Krisinformation, 2023).

Climate changes also make it essential for us to think about how to handle sewage water (Alpman, 6-2022). Access to clean water is a necessity and a human right, otherwise there is a big risk for conflicts. In Sweden, many municipalities have problems with low water levels, the reason why it is common with watering restriction during spring and summer (IVA, 2021). 95% of the sewage water is grey water from bath, dish and laundry, water that easily can be reused locally for watering and flushing toilets (Granmar, 2021). By doing so, the risk of lacking water will be reduced.

Based on this, a circular mindset can help,

the reason for the title of this thesis *A circular home*. In this context, a circular mindset is seeing the situation as a part of a larger whole and attempt to find solutions, for example how to create your own resources such as electricity and food. Solutions that can continue to function and develop over time. Make sure the resources get used as efficient as possible and then recycle whenever possible, so it becomes something more. A circular lifestyle to support independency and resilience. It relates to how we prepare ourselves and the architecture we live in to support another future we do not know what to expect from. We need to have a plan how to handle different scenarios. It can be a storm creating an energy supply disruption, a dry period causing crop failure, floodings shutting of infrastructure and other fearsome scenarios.

So, what kind of house will support us the most?

AIM & PURPOSE

The thesis aims to design a more independent dwelling where architecture act in symbiosis with nature by using given resources in a more efficient way. The purpose is to investigate how we can live in tune with the surrounding in a more resilient way and through that give an answer to how architecture can respond to environmental issues such as water- and energy supply and how our homes can contribute to a more circular lifestyle.

RESEARCH QUESTION

How can building design and its materials contribute to resilient architecture, utilizing the resources from nature?

DELIMITATIONS & ASSUMPTIONS

Usually, the architect has great help from an engineer to analyze the indoor climate and energy demand of buildings, but as it is a thesis in architecture it will focus on the architectural tools and not dig deep into advanced calculations. Today there are plenty of technical solutions on the market to create a good indoor climate all year around and they probably create a more even temperature, but it will not be evaluated in this thesis. Furthermore, the design implementation will enable farming, but the thesis will not include guidelines for farming or how to be self-sufficient. The investigation focuses on a climate like Gothenburg and the design phase will result in a single-family home, to rather give time to put focus on the exploration of tools.

METHOD

Research

The thesis started with finding references and literature studies to get background knowledge that the research is built on. During literature studies I took notes, summarized, and then analyzed and compared it with other references.

Site analysis

The site was analyzed to understand the conditions as the orientation, the terrain, and connection in small and bigger scale but also if there is a local plan and municipal water.

Sun study

The movement of the sun during different seasons and times of the day was thoroughly studied, to guide the design work.

Study visits

I have also visited one project to observe how the house works, how indoor and outdoor spaces are connected and take photos. Observations were analyzed and compared with other built references and some of the findings are implemented in the design project of this thesis.

Interviews

During the study visit I did spontaneous interviews and got thoughts about the advantages and challenges with living like this. I have also had extra tutoring with one experienced in the field.

Building program

The functions and its connections within the building is described through a building program, which gave me important information for the design phase.

Diary

During the process I have been writing a diary for myself to informally write down reflections.

Architectural tools

The design phase included volume experimentation through sketches and digital models. The building volume with its interior spaces, layout and materials was developed with climatic architectural tools in mind.

BACKGROUND

The following chapter introduces existing typologies in the field and methods for how to think about sustainability and resilience. It starts with inspiring projects, outside architecture, and then continues to built example, both contemporary and traditional vernacular architecture of the Swedish countryside hundreds of years back. The chapter ends with an important discussion of the field.

BOTTOM-UP PROJECTS

To create a sustainable future, more resilient in relation to both environmental and societal challenges we need to start from a single house or a cluster of units. The inspiration for this thesis comes from a wider context than architecture, the reason to introduce them briefly. The following are examples of how this have been done in energy supply, both in Sweden and in other countries.

The first example is from Bangladesh. Neil Tamana studied Alternative energy technology. Afterwards he returned home to help power his country. He made a solar home system where the inhabitants bought a solar panel, a battery and a device, he calls a solbox. The solbox connects the houses together and makes it possible to buy energy from others. If you have less money, it is enough to just buy a solbox and expand the system later. It all becomes a decentralized microgrid that can grow bigger and bigger. The goal is to make it the country's primary energy source (Gameau, 2019).

The next example is Simris, a small town in the southern Sweden. The town have been pilot project for local energy production, a part of InterFlex EU project. The project is to shut it off from the national energy system and make them power self-sufficient. They have three different sources of energy: sun, wind and an emergency power unit driven by renewable fuel. The project has several advantages: the user gets more aware, and hopefully use power more efficiently; the energy supply can be made more reliable and energy losses due to long transportations can be reduced. This can beneficially be used for isolated places, for example an island (E.ON, 2024).

TRADITIONAL BUILDINGS

There are lots to learn from older building traditions, here with a focus on Sweden. The architecture of the countryside is closely connected with the surrounding nature and often described as picturesque and romantically structured. The easiest cottage just contains one room, squared shaped, with four to six meter long walls. It is built with materials they found nearby and has the stove placed in the middle. All of life took part in this room- they gave birth, worked, and died here. Later, the cottage was built with several rooms such as vestibule, chamber, and kitchen. The living room was still an important common space. During the coldest months, everyone gathered here and slept in the same room to stay warm. When constructing those houses the social norms put unwritten demands on loyal architecture, no bragging constructions. They choose either a single house or a duo house. The

duo cottage belonged to a farm of medium or big size and the single houses belonged to smaller farms. The duo house could be shared between two household living together and the single houses were for example usual for soldiers to live in (Werne, 1997). During the late 19th century there was a reformation towards higher quality on buildings in rural areas. The architects Adolf Vilhelm Edelswård and Charles Emil Löfvenskiöld made several prototype drawings. The raised quality resulted in buildings that was easier to heat, gave a more economic use of materials and was more practical. The building was divided into four squared rooms and the stove in the middle. Some of the typologies, especially the single house and duo house, are still common in the Swedish countryside, thanks to its adoptability to changing needs (Palmqvist, 1995).

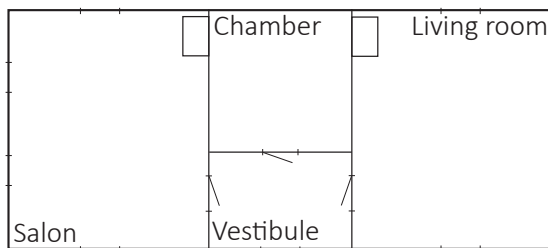

Figure 1 - an example of a duo cottage

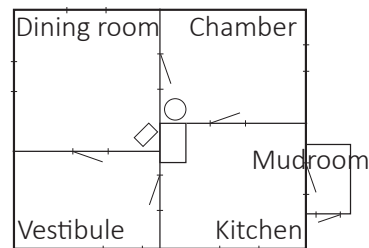

Figure 2 - an example of a single cottage

PASSIVE HOUSE

A building typology, developed for being energy efficient, is the passive house. It was done in Germany during the 90's by building physicist Wolfgang Feist. The concept was then firstly done in Sweden in the beginning of the century. 2018, Sweden had 35 multifamily houses and 50 villas certified as passive houses (Passivhuscentrum, n.d).

The building construction is well insulated and airtight to minimize heat leakages for example around doors and windows. The building has most of its insulation in the roof, where hot air automatically gathers. The heat mostly comes from the sun and therefore bigger windows should be placed towards south. As it is more airtight than a traditional building there is a risk for overheating during the

summer and the big windows towards south benefit from being complimented with some kind of shading. The building is also heated by surplus heat from the users and electronics. Furthermore, those building are usually equipped with a mechanical ventilation system, which distributes indoor air and makes sure every room stays warm. During the coldest days of the year in the Nordic climate, it is sometimes not enough, and the heating system benefits from a complimenting fireplace or heat pump. The typology is approximately 10% more expensive, but the investment pays off in the long run thanks to its low operating cost. In addition to that, passive houses have better air quality than traditional houses (Passivhuscentrum, n.d).

NATURE HOUSE

The last one is called *naturhus*, or nature house, translated to English. It was developed as new sustainable building type during the 70's by the architect Bengt Warne, when the oil crisis was one of the hottest global topics. It is defined as a dwelling which interacts with nature in a circular flow. It borrows resources from nature and gives it back in the same condition (Warne, 1993).

A nature house has some kind of core house with usual living functions and then a surrounding glass construction. This solution decreases the demand for heating up to 30%. One nature house was measured during a year and while the outside temperature span was -29 to +34, the span inside the greenhouse was 0 to +27. The mediterranean climate inside the greenhouse gives 25% more hours for farming and having a temperature over zero degrees all year around makes it possible to grow things that usually does not fit here (Granmar, 2021).

Granmar (2021) explains that the surrounding greenhouse also makes it possible to use a wide range of different materials for the core house; traditional timber construction, modern timber construction, straw bales etc. and there is no need to treat or paint it as it is not exposed to rain and wind. Another advantage of the greenhouse is that you can stay in the sun without being exposed by dangerous UV-light.

But it took until 2006 before the concept was used again. Now there are around 20 houses in Sweden. Most of them are built from scratch. There is also one example of transforming an existing house into a nature house, by capsulating it with a glass construction and adding a circular system. People living in nature houses also experience it changes their behaviors and makes them conscious about what they flush in the toilet, not doing half-filled laundry machines, what detergent they are using, etc (Granmar, 2021).

LIVING OFF THE GRID

The concepts described are closely connected to off-grid living and self-sufficiency. Traditional buildings are linked as it was their prerequisites, but nature houses and passive houses were developed because people so desired. So, what are we looking for? Bradbury (2019) establishes reasons for why people want to live off the grid.



Figure 3 - Sustainability

One person is wishing for a more sustainable future and therefore starts on a personal level by reducing the own environmental footprint. This person probably wants a real understanding of our resources and have a will to use them respectfully (Bradbury, 2019).



Figure 4 - A place

Next person have fallen in love with a special place as the off-grid concept gives the possibilities to live wherever you want, even on isolated place, just because you serve yourself. To be able to fulfill the off-grid-dream the house needs to reduce its energy and water requirement and use different techniques (Bradbury, 2019).



Figure 5 - Farming

The last person has green fingers and loves to farm and wants to become closer to self-sufficient (Bradbury, 2019). A nature houses could then be the solution as they have a surrounding glass construction creating a Mediterranean climate and you can pick exotic fruits and vegetables inside your home (Granmar, 2021).

The common motivation is the special sense of freedom, to liberate from traditional network, both physical and social, if one wants to and instead be a part of the nature. To clasp the calmness and actualize one's true appreciation of nature and a wish to have a meaningful connection with the surrounding (Bradbury, 2019). The design work of this thesis has sustainability aspects as its starting point.

NUDGING

As the environmental situation is urgent, we need to rethink what life we are designing for, without relying on previous patterns. We need to make sustainable and resilient choices in our design and facilitate a lifestyle that is less resource intense. Then nudging can be a tool to use.

Nudging is commonly used for commercial purposes, but also to promote sustainable behaviors. It includes strategies encouraging the user make a certain choice or action in a predictable way without taking away any options or significantly change the economic prerequisites. By conscious design decisions it is possible to utilize our trained pattern to promote a behavior. For example, in architecture we can change how things are placed and thereby change the default option, and it is called choice architecture (Löfgren &

Ylenfors, 2023). As Granmar (2021) explains, nature houses have a nudging impact. By placing the water handling system onsite, the user gets more aware.

Humans have two cognitive systems, one automatic and one reflective. The automatic system is used for quick decisions, made without considerations. When taking those decisions there are some default patterns to keep in mind. For example: we are lazy by nature and choose what requires minimal effort and what is presented in most appealing way, and nudging goes hand in hand with social norms- we tend to follow the big group of people. 95% of our behavior is controlled by the automatic system, so if nudging can influence this part there is a great potential to utilize (Löfgren & Ylenfors, 2023).

CONSEQUENCES OF SMART HOMES

An important topic rarely discussed is the possible consequences of technical controlling systems.

Many manufacturers of the systems envision the monitoring to have an amazing impact on life in the house, like reduced energy consumption, but there are as well some risks to keep in mind. One risk with smart homes is security. Some systems are not protected by any password and therefore outsiders potentially can hack the system and use the consumption data to determine if anyone is in the home, for example before committing a burglary. Secondly, the social consequences of smart home technology. By installing a smart home system, the control of the home turns to the most tech-engaged

household member, typically the man, which creates an imbalance between the household members. The reasons for less participation can either be lack of access to the software, for example knowledge about passwords, or lack of interest and skills (Nicholls, Strengers, & Sadowski, 2020).

By designing homes that passively, without numbers of remote controls, adapts its climate according to time of the day and day of the year reduces the risk for this imbalance.

Other questions of smart homes that is important in the long-term perspective is, what happens when you move, will the new user get problems?

DETACHED HOUSES AS TYPOLOGY

The single-family house is nowadays a debated typology. The critique is that it takes huge areas compared with how many that can live there, and it enhances the car dependency. Usually there are two ways of developing an area. Either high and sparsely, or low and dense. Garden city planning, with detached houses can belong to low and dense, if well designed (Nordström, 2024).

Several surveys through the ages have shown that a majority wants to live in a house with an own garden. But, sometimes the surveys are answered without keeping the cost and the location of the site in mind. When asking people where they want to live, a majority says centrally, where small houses are hard to find or build (Nordström, 2024).

On the other hand, the request of small houses is raising, also as an effect of the pandemic, while the number of smaller houses built in Sweden today is at its lowest point seen to the last 100 years. This, even though we are one of the countries in Europe with best access to buildable land. Single house areas are often perceived as safe. One third of the million homes program was single family houses and none of them are an exposed area today. Having an own garden is good for families with kids as it enhances the opportunities to regular contact with nature, which research shows improve kids' development (Söder, 2021).

DESIGN STRATEGIES

To maintain the human body at 37 degrees the surrounding need to be slightly cooler, between 20 and 28 degrees. This temperature is rarely found outside and therefore this space needs to be built artificially, by encapsulating air, and raise its temperature to a comfortable atmosphere (Rahm, 2023). A house also needs to handle sewage water and get fresh air and more. Lots can be solved with mechanical systems such as ventilation units, radiators, and fans. Those are electrically powered, in need of maintenance and replacement. It can also be solved with passive, vernacular solutions, without on and off-switches, as tools for the architect to take care off. Then the building does the work and correctly designed, little can go wrong (Day, 2016). Those design tools are the theme of exploration in this chapter. The following quote is not necessary to understand in detail, but it showcases another mindset of creating architecture, and sets the basis for this study.

” *Can we base a section on a convective flow?
Establish a plan based on gradations of light insolation?
Choose a material according to its thermal effusivity,
design a facade according to its thermal emissivity?”*

(Rahm, 2023)

Glossary

Convection: The air movement caused when heat is released from a hot surface, for example a radiator. Hot air is light and will therefore rise, repelling cooler air downwards (Rahm, 2023).

Effusivity: Two materials of different temperature, placed in contact with each other, transferring heat between. The hotter material will heat the cooler. Effusivity affects the perceived temperature - if two materials have the same temperature, wool or earth will still be perceived hotter than ceramic or aluminium (Rahm, 2023).

Emissivity: How much heat a material obtains, the opposite to reflect. The emissivity is closely connected to its radiation. It depends on the type of material, its roughness and color (Rahm, 2023).

TEMPERATURE REGULATION

Orientation

One of the main resources is the sun. The sun shines on every home, many days during a year and if the designer have the right tools this energy can be used in an efficient way. The first thing to pay attention to is the orientation of the house. True south is preminent for gaining as much solar benefit as possible. When a house is turned it quickly loses sun benefit (Kachadorian, 2006).

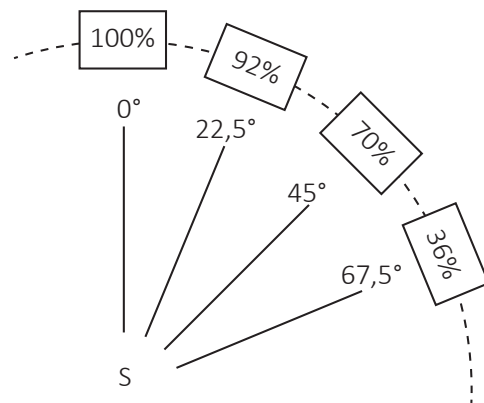

Figure 6 - Solar benefit related to angle & orientation

Angle of the sun

The amount of sun striking the house depends on the season, the time of the day and the latitude of the site. The sun angle is steep during daytime in the summer while it penetrates the house deep at the same time during winter (YR Architecture Design, n.d).

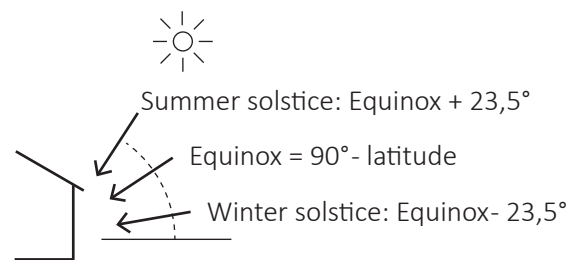

Figure 7 - Calculation of sun angle

Blocking the sun

When designing with the sun there is a notable risk of overheating the building during the summer. Cooling a house by using electricity takes three times more energy than heating a house, so by blocking the sun during the summer there are energy and money to save. Following are design strategies to block the sun.

Roof overhang can be used to block the sun from getting in during midday in the summer.

The temperature can also be regulated with shading elements by the windows, either inside or outside. They can be used for keeping the sun out, but also to avoid heat to leak from the house during night.

For the surrounding, trees are a good way to regulate the house temperature as it shadows during the summer, when the leaves are there, and let the sun shine on the house during winter season (Day, 2016).

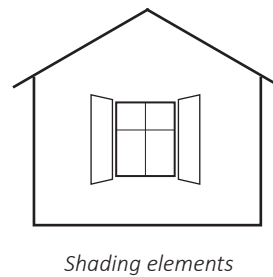
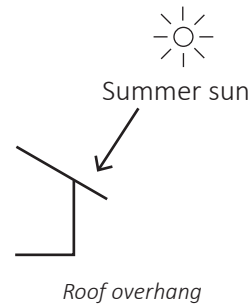

Figure 8 - versions for blocking the sun

Materials

The choice of materials makes a big difference for the indoor climate. When sunlight hits a surface, it is transformed to energy, in form of heat (Kachadorian, 2006). How the material handles this heat depends on three criteria:

- Its ability to transfer heat
- Its heat storage capacity
- Its density (Rahm, 2023)

Materials with slow heat transfer, high heat storage capacity and high density will further on be called massive materials. Examples of massive materials are concrete, stone and raw earth. Heat will always travel from hot to cold, but the time it takes varies according to material. With concrete or stone the process is slow and therefore it gathers heat during daytime when the sun is shining through the windows. The heat is then released back into the house during nighttime (Kachadorian, 2006).

Massive material can be placed in the slab or in the wall, the principle is the same. It requires ventilation gaps, where the warm and the cool air can circulate. The relation between the massive materials and the amount of windows is sensitive and determines the indoor temperature. A guideline is 10-20% of the wall should be windows. The further north a house is located, the area of windows towards east and west can be decreased to get more morning and afternoon heat gain. To do calculations of solar gain and heat storage the following values are needed:

- R-value (heat resistance) for wall and roof materials, and for the windows.
- The shade coefficient of the windows (how much sunlight gets through).
- Annual percentage of sun on the site. (Kachadorian, 2006).

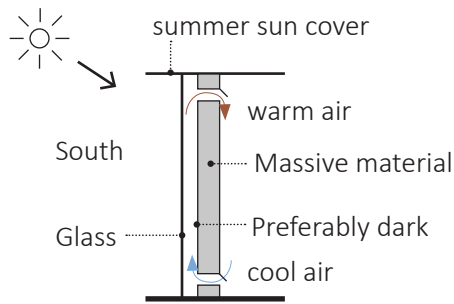

Figure 9 - Tromb wall

Tromb wall is a design principle for exterior walls. The sun hits a south facing glazed wall and the energy is transformed to heat in the massive wall behind. It is even more efficient if the wall is dark on the outside. To avoid the reverse to happen, the openings need to be closed during night (Kachadorian, 2006).

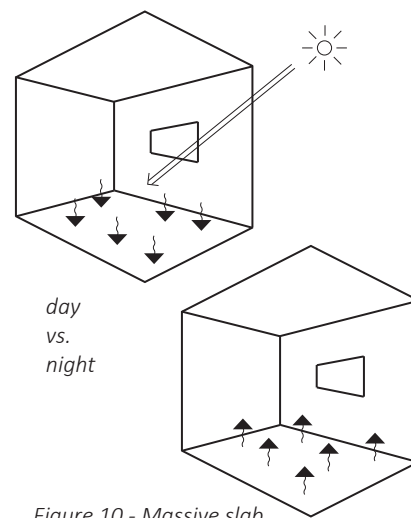

Figure 10 - Massive slab

The massive material can also be placed in the slab. When the principle was done in a slab, measurements showed that the temperature only varied 4,5 degrees during a day in February (Kachadorian, 2006).

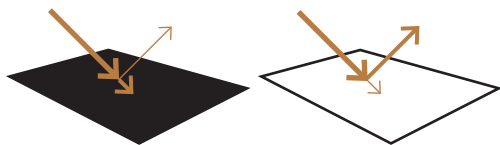

Figure 11 - Coloration

Another aspect, except the massiveness of materials, is the color of it. Black surfaces absorb heat whereas white surfaces reflect it away. This can be used to keep the heat away, gather more heat or transfer light further into a building with a light flooring (Rahm, 2023).

FLOORPLAN DESIGN

In the initial scenario the southern wall and the roof gets lots of sunlight, while the northern side remains cold, especially in the lower part (Rahm, 2023). The heat distribution inside the building can take advantage of this pattern in several ways.



Figure 12 - natural heat distribution

Diurnal rhythm

Rooms can be organized according to sun movement and what time during the day we preferably use the space. By doing so, both the heated space and the sun follows our pattern. We start our morning in the bedroom, then go to the toilet and afterwards we are heading to the kitchen for eating breakfast. Therefore, it is good to have the

kitchen and dining area placed on the eastern side, where the sun rise, and it becomes warm first. The northern side is coldest most suitable for storage and communication. The woodstove should be placed centrally to best distribute its heat, in a room where the houseowners hang out a lot (Day, 2016).

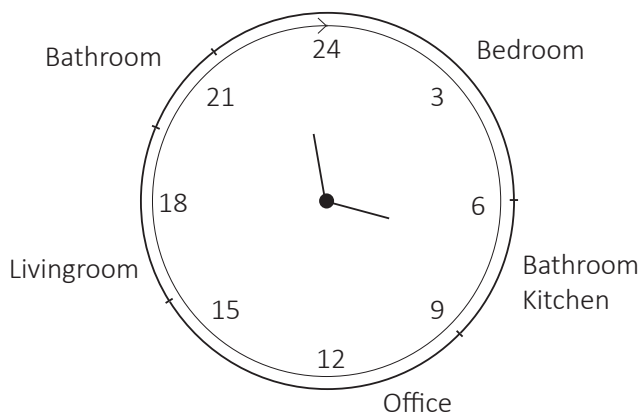

Figure 13 - Occupance of spaces

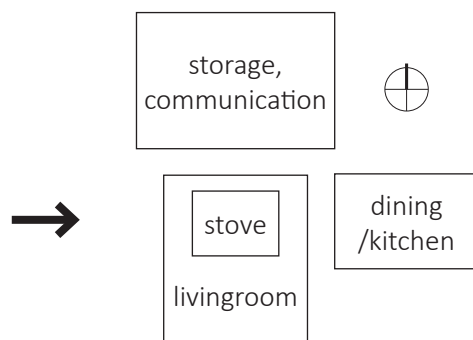

Figure 14 - Floorplan configuration accoring to orientation

Vertical temperature grading



Rooms can also be organized according to air flow and what temperature we want in different rooms. The comfortable temperature depends on our level of activity and nudity. The room where we take a shower should be hottest and communication zones where we maybe run up and down a staircase can be colder. Since hot air rise, a house preferably has several stories. Then, hot air can be reused further up in the building. By having different temperature requirements on different rooms, it is possible to be more energy efficient. A layout can then be designed in different levels related to appreciate temperatures and take advantage of physical laws (Rahm, 2023).

Figure 15 - Temperature and space

Microclimate

Wind is transporting heat, cold and moisture. The wind from north and east is cold and dry, while the wind from south and west is warm and wet. The northern wall is therefore good to give thicker insulation, but also suitable for storing logs. Rooms that need higher temperature should be placed in the middle or along the hottest wall. The building can be protected by the typography of the site, trees, hedges and surrounding building acting as windbreaks. They create a microclimate around the house, increasing the outdoor comfort and reducing the energy need inside (Day, 2016).

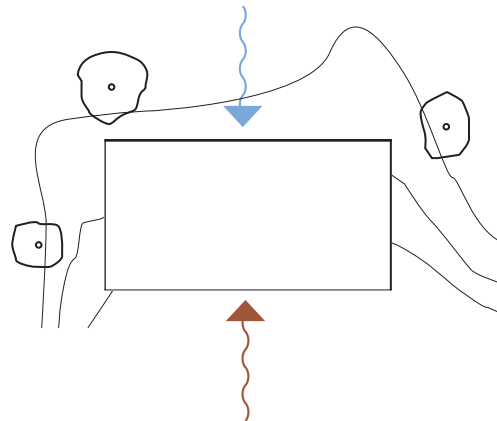

Figure 16 - Building microclimate

GEOTHERMAL HEAT

One energy saving method for heating and cooling buildings is to use an earth tube; the fresh air intake goes through a pipe dug down to change the temperature of the incoming air. It preheats the air during the winter and pre-cools it during the summer, thanks to the more even temperature in the ground around the year. The effect of earth tubes as heat exchangers depends on the type of soil and climate as well as the radius and length of the pipe and what depth it is placed on. The longer tube, the larger is the effect,

which can be used to get different effect for different rooms according to temperature requirements for each room (Grygierek & Ferdyn-Grygierek, 2022).

The study made by Grygierek & Ferdyn-Grygierek (2022) are done in southern Poland. The system they evaluate have pipes made of plastic with a radius of 0,055 m and it is placed 1,6 m down, while Rahm (2023) says the pipe can preferable can be put 5 m down.

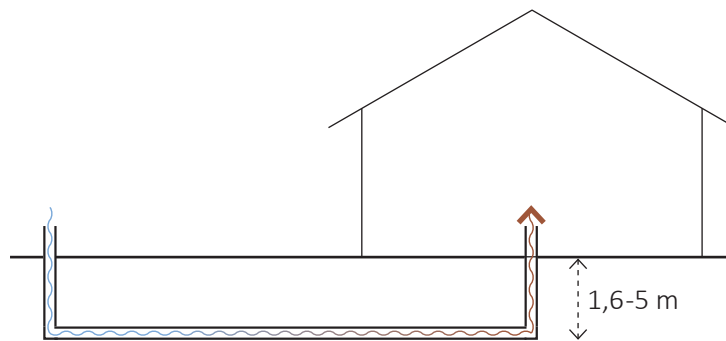

Figure 17 - Earth tubes when it is colder outside than inside

WATER & SEWAGE

Incoming water can be from a private well or from the municipal water system, depending on where the house is placed. Municipalities often demand all houses inside their water system to be connected, but even though it is possible to reuse it before (Granmar, 2021).

Reusing sewage water is a way to handle lack of water. An urban developing project in Helsingborg, Oeanhamnen, is testing a new way to handle sewage. The only difference for the inhabitants is vacuum toilets and a compost mill installed in the kitchen. Vacuum toilets use 0,5-1 liter per flushing, compared with 6 liter per flushing for a normal toilet. Their sewage is then divided into three pipes; one from the toilet, one for compost and one for grey water. Grey water is cleaned through biological cleaning and filters. Afterwards, it is clean enough to drink, but not according to regulations. Therefore, it is just used for watering plants, but it can also be used for flushing toilets and filling pools. Water from toilets and compost gives nutrients to be used as fertilizers (Alpman, 6-2022). Depending on which parts is reused the volume of nutrients will differ and thereby the size of farmland it can feed.

Another part of using water is to gather rainwater. It can be used for watering, flushing toilets, shower, do the dishes, and for laundry. Rainwater gathering requires big tanks and those can beneficially be dug down (Granmar, 2021). Gathering rainwater locally also help during heavy rains and reduces the risk for floodings.

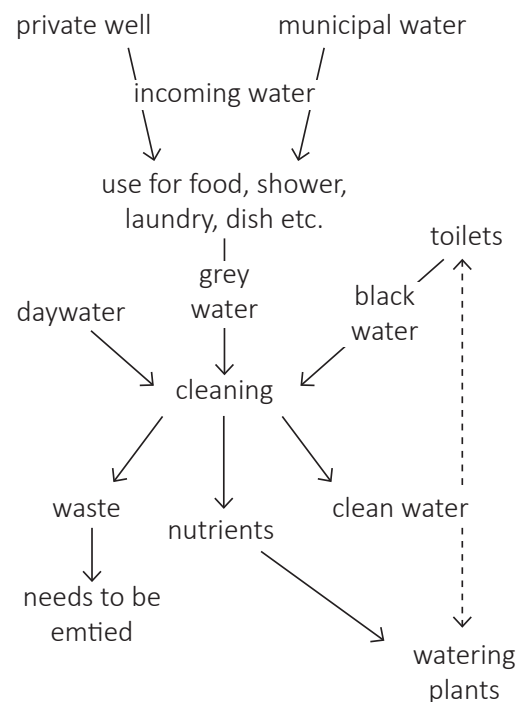

Figure 18 - The water circle

USE OF RESOURCES

Some of the resources from nature that we can take advantage of in architecture are water, sun, and wind. With conscious design decisions they can cover most of our basic needs as food, fresh water, heat and today it can also be argued electricity is one of them. But, according to challenges with creating a sustainable future there is a need to handle the resources sensitively. The waste hierarchy can therefore be implemented on the design strategies.

The waste hierarchy contains five steps: prevent, re-use, recycle, recover, and dispose. Prevent is about minimizing the amount of waste by producing less potential waste. The waste hierarchy then distinguish between by-products and waste. The re-use and recycle stage can be clustered as by-products. By-products can be created by giving it some love, a new function, or a new user. If none of the previous steps is not possible, the energy from the material can be recovered or the last alternative, deposit it (European Union, n.d).

PREVENT

*Use the resources given by nature as efficient as possible, for example by correct orientation of the house and calculate the amount of windows to get the most out from the solar energy.
Prevent can also be to not grow more vegetables than needed or have greenhouses big enough to utilize the fertilizers from the water.*

REUSE & RECYCLE

*The built up heat should then be kept inside the building by insulation, heat storage and an optimized volume.
Also, have places to store grown food and gather daywater for coming needs.*

RECOVER

*Use the they greywater (and the black water) as fertilizers.
Sort waste and make compost of food leftovers.*

Summary of design strategies arranged in relation to the waste hierarchy.



ORIENTATION

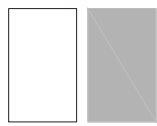

COLORATION

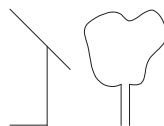

SHADING

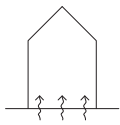

GEOHERMAL HEAT

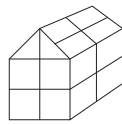

GREENHOUSE

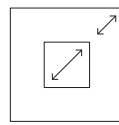

OPENING RATIO



FLOORPLAN

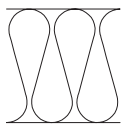

INSULATION



AVOID LEAKAGE

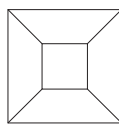

SPATIAL VOLUME

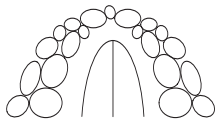

FOOD STORAGE

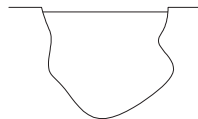

GATHER DAYWATER

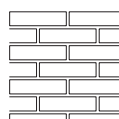

HEAT STORAGE



COMPOST



REUSE WATER

→ **DISPOSE**

REFERENCES

ANKIS NATURHUS

This house is designed by Tailor Made Architects and was finished 2021. The wish of the client was to get a calm place in the nature, an energy efficient home and a Mediterranean climate zone where she could plant. Being self-sufficient was not a driving force. Her house consists of two modules she

found second hand. Those were merged with an orangery and covered by a greenhouse. One module includes the private bed- and bathroom and the other one contains a kitchen and a guest room. The orangery is the common space binding them together (Gullbring, 2022).

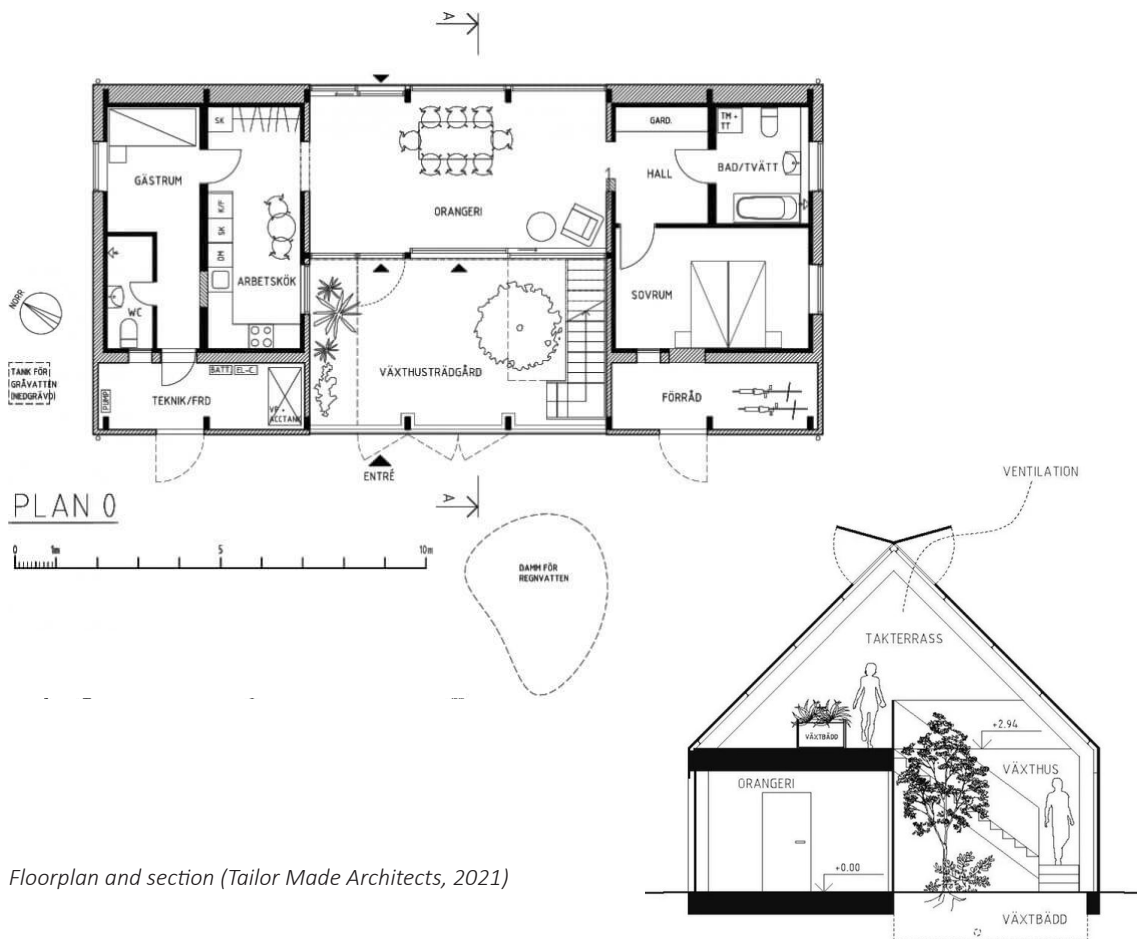

Floorplan and section (Tailor Made Architects, 2021)

The limit between inside and outside is almost transparent with the glass roof which lets you see trees turn according to season, stars shine bright during night and the sliding doors make it possible for the air flow through the house. Textiles and trees are softly shadowing the house a gives harmonious light inside. The only thing blocking the view is the solar panels along the ridge, but they also help shadowing the plants.

The greenhouse is built with cross laminated timber, 4 mm glass and aluminum profiles between. Rainwater is gathered in a pond in front of the house and reused for watering plants and flushing toilets. Only 10 % of the grey water is left to the municipal system (Gullbring, 2022).

The facade is covered with larch panel with bottoms cut like a v, which both contributes to a softer landing on the ground but also makes rainwater drop off, so the panel lasts longer. The door into the technical room is smoothly hidden in the larch panel to give prominence to the entrance. When entering the house, you reach a spacious room with double ceiling height and plants on both sides.



Top floor



The entrance, side towards the street



The view outside, standing in the orangery

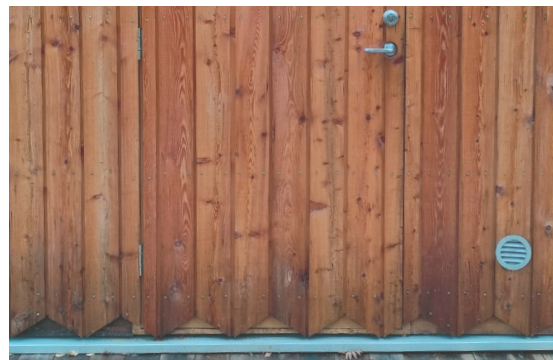

The larch panel and the hidden door

VILLA IDUN-LEE

The house is made by architect Per Nadén and Anton Kolbe in collaboration with their client, Axel Von Friesen and Marika Vaccino. It is built on Saltsjö-Boo, in the archipelago of Stockholm, 2016. During 2020, the architecture was honored with *Träpriset* (Svensk trä, n.d), a price for its use of wood as a material.

When standing on the outside it looks like a wooden building, melting together with its surrounding pines. The gable has an unusual panel with some planks on its short side, which gives dynamic to the otherwise quite closed side. Despite the volume's variety in closed and open towards different directions and its playful positioning of windows, it has a coherent attitude.



Exterior (Per Nadén, 2016)



Interior (Per Nadén, 2016)



Front window (Per Nadén, 2016)



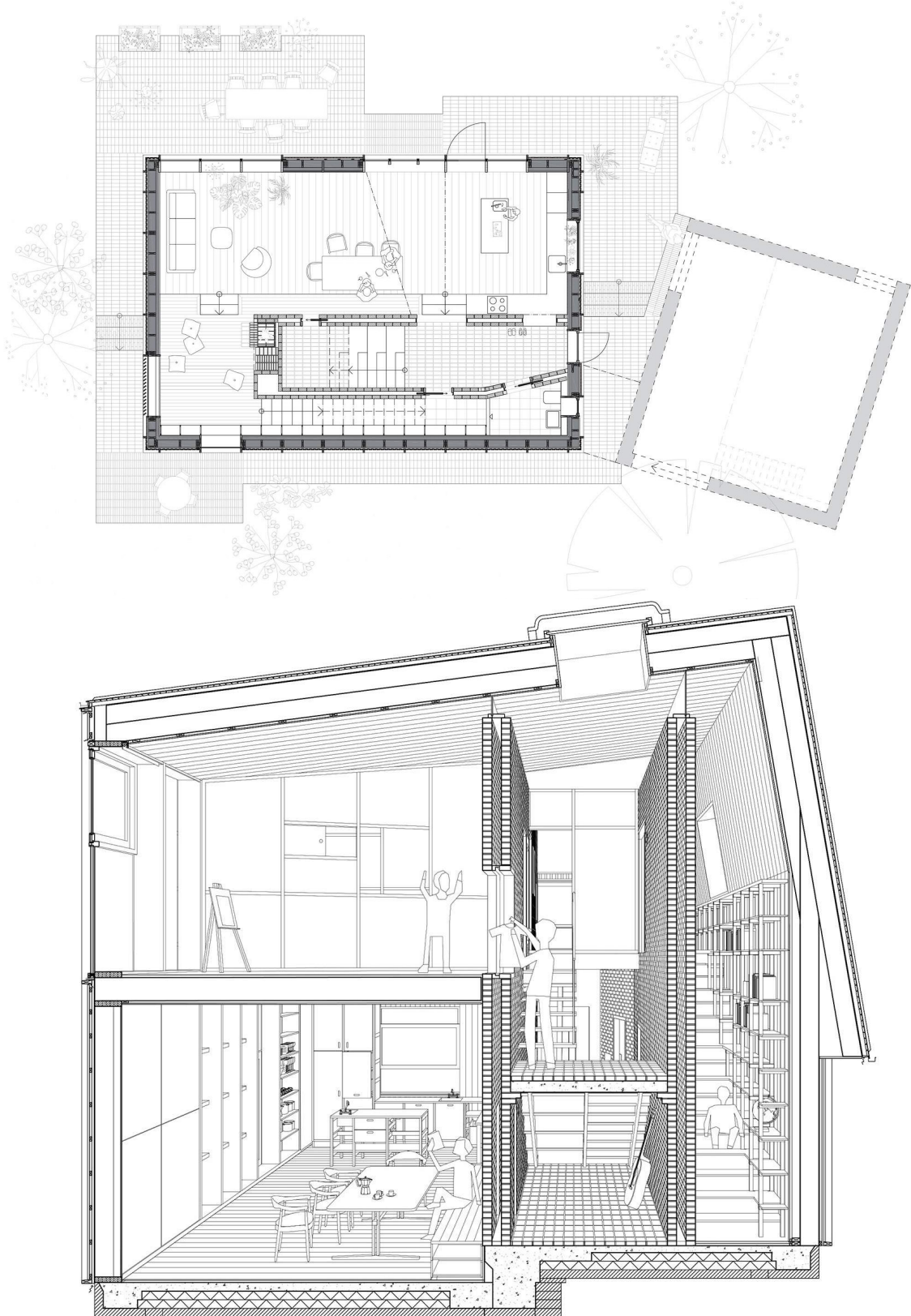



Going inside, the material palette is complemented by bricks, stabilizing the construction (Svensk trä, n.d). The heavy material beautifully interacts with wood and glass. Towards south a high window from floor to ceiling trough two levels welcomes the visitor. The common area is placed two steps down. The steps continue as a bench, specially built for this project, like many other furniture here.



Floorplan and section (Per Nadén, 2016)

CHAPTER IV - REFERENCES

PROGRAM COMPARISON

Room	Area	Ankis nature house	Villa Idun-Lee
 Kitchen + dining + livingroom		70	87
 Bathroom		9	7
 Bedroom + office		20	28
 Communication + hallway		14	22
 Storage + tech		16	3
 Farming		25	

Ankis Naturhus

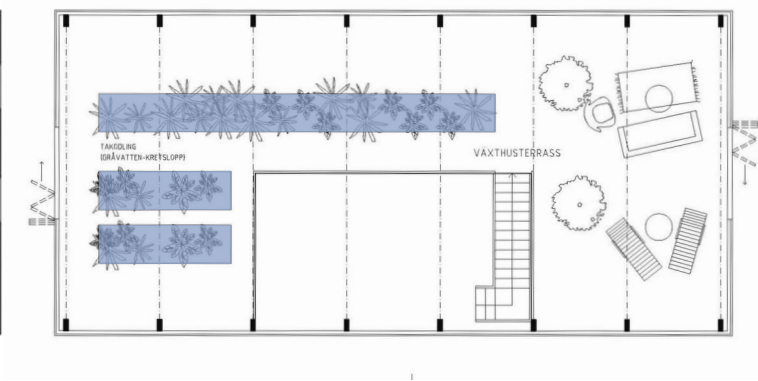

Villa Idun-Lee

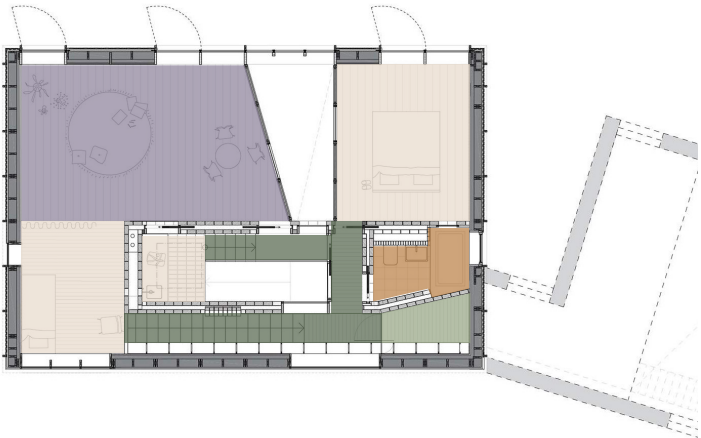

DESIGN PROPOSAL

BUILDING PROGRAM

Core house

Entrance	6 sqm
Living room	15 sqm
Kitchen	10-15 sqm
Three bedrooms	8-10 sqm
Bathroom	3-4 sqm
WC	2 sqm
Laundry	8 sqm
<hr/>	
	68- 80 sqm
With communication area & walls >	GFA: about 100 sqm

Winter garden

Cultivation	min 20 sqm
Seating	10 sqm
<hr/>	
	30 sqm
With communication area >	GFA: about 40 sqm

Other

workspace	5 sqm
Storage for wood	5 sqm
Storage for food	10 sqm
Water tank for rainwater (outside)	
Possibility for solar panels (roof)	10 sqm
Possibility for solar collectors (roof)	10 sqm*
Tech-room	5 sqm
pump, battery, water cleaning	
accumulation tank- solar heat- 800 liter*	
accumulation tank- pellet or wood- 600 or 2000 liter*	<i>*(combiheat, 2023)</i>

core house

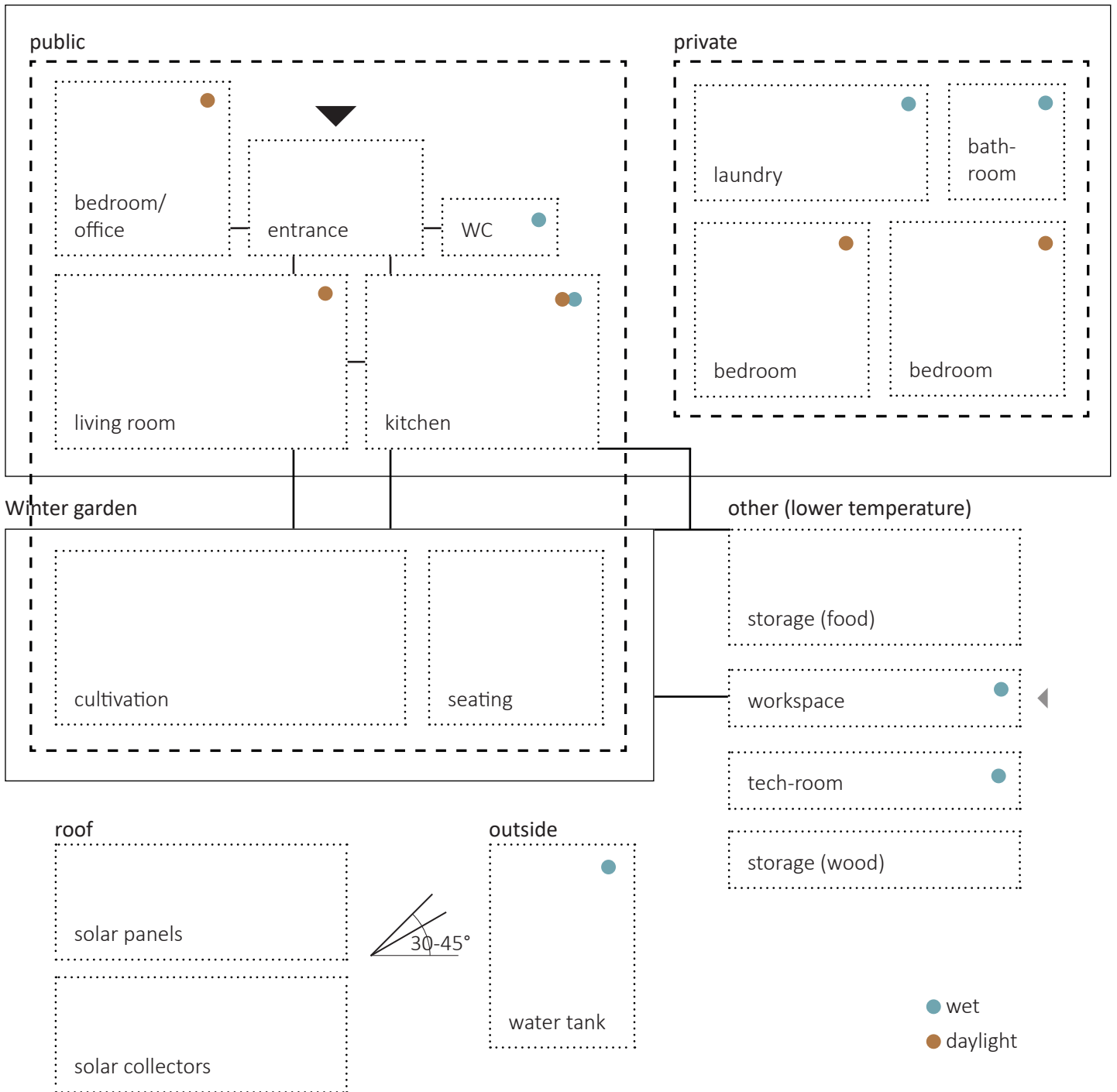

THE SITE



Description & analysis

The site of the project is located in Härryda municipality, a neighbor to Gothenburg city. It is approximately half an hour to the city center with bus or car. The closest bus stop is just 300 meters away. Here passes the bus between Mölnlycke and Bollebygd, and the bus from Landvetter to the airport. From Landvetter there are three alternative buses to the city of Gothenburg.

Except for the things pointed on the site plan there are grocery shops, restaurants, a hotel etc. within 5 km. The place offers great recreational potential where you can walk, take the bike, or pick blueberries and mushrooms.

The area has no municipal water connection and there is no detail plan. The site is open and therefore has good conditions for utilizing the sun and also sloping a little bit towards southeast.

The highway has heavy traffic, but the distance is far enough to avoid it as a problem. What is more substantial is the noise from the airplanes. A future potential for the site is the frequently discussed train stop in Härryda or Landvetter, but no decisions are made yet.

CHAPTER V - DESIGN PROPOSAL



SUN STUDY

Here is an extensive analysis of the sun movement during summer and winter solstice, spring, and autumn equinox. Summer solstice is the brightest day of the year, and it happens when Swedes celebrate midsummer. Then the sun is at its highest point, and it takes the longest loop from east to west. Winter solstice is the opposite, the darkest day of the year, with the lowest angle and

shortest loop. It occurs some days before Christmas. Equinox happen two times a year, both in the spring and the autumn, and it is when the light part of the day is equally long as the dark part of the night. The analysis also explains what time of the day the sun rises and sets. The sun study is made for north latitude $57,7^\circ$, where the site is located.

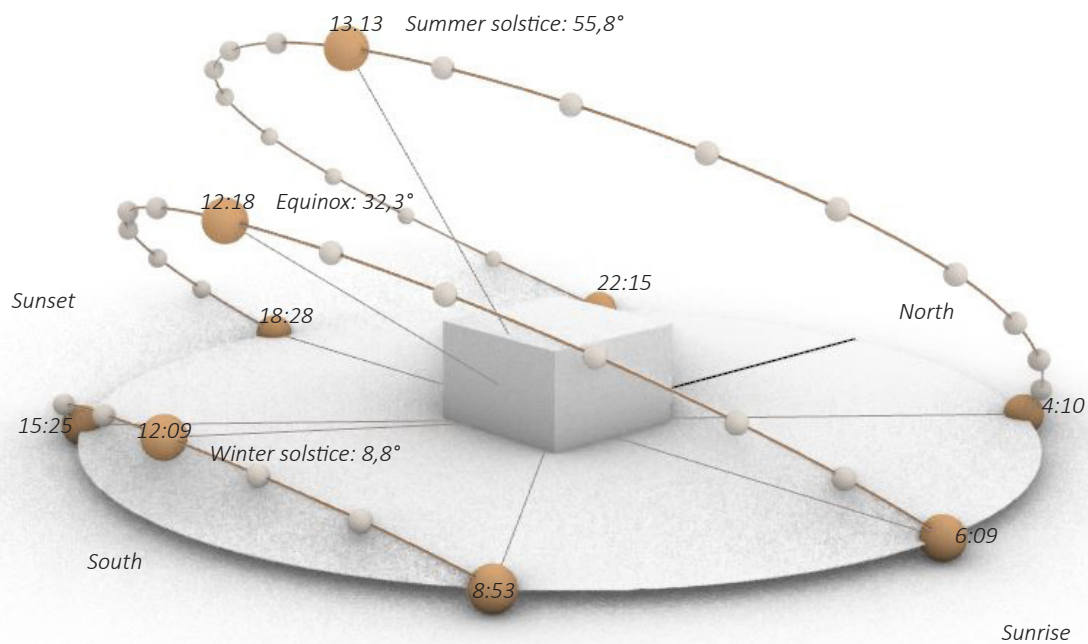

CHAPTER V - DESIGN PROPOSAL



The site from west



The site from north



Mölnalsån



The road where the bus stops



Surrounding buildings



View towards the golf course

FLOORPLANS

The design strategies with the references together made the starting point. The proposal is somewhere between a passive house and a nature house, while it also has elements from traditional buildings. It gives opportunities to farm and reuse water, like a nature house, but it is not enclosed in glass. Rooms are placed according to what time of the day they are used and temperature requirements in relation to sun movement. The rooms are mostly squared shaped, like the traditional building examples. The entrance to the building is on the northern side together with the staircase, the all-round room for doing the laundry or replanting and a bedroom. The kitchen is on the eastern side and the living room towards west. The

common spaces are allowed to expand and shrink into the wintergarden between according to need and season, thus blurring the boundaries between outside and inside. The tube from the kitchen fan is hidid within the brick wall and extra heat can be produced in the stove and delivered to other rooms through the core wall. On the second floor there are two more bedrooms and a bathroom. The spatial experience of the greenhouse is extended through two entresols stretching out on top of the living room and kitchen. The space can be shut off for a wider scope of use. Either it can be a social area, or a possibility to grow greenery in need of a hotter surrounding. The house is totally 166 sqm.



Rendering from the kitchen

15th May, 1pm

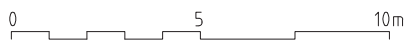
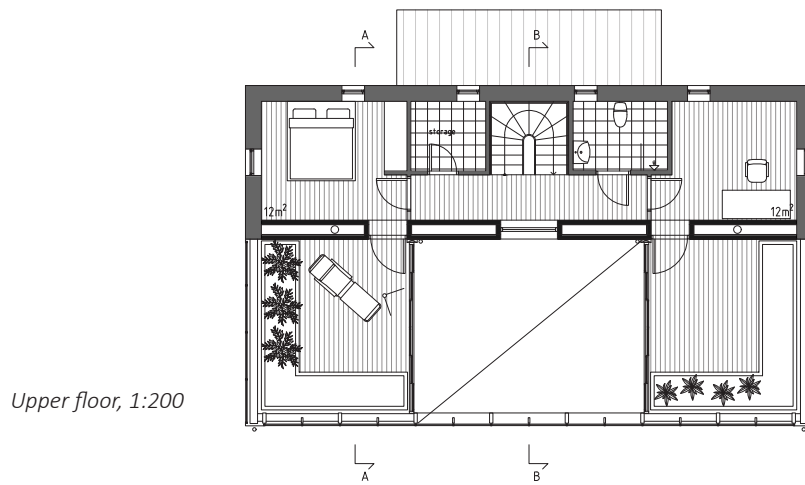
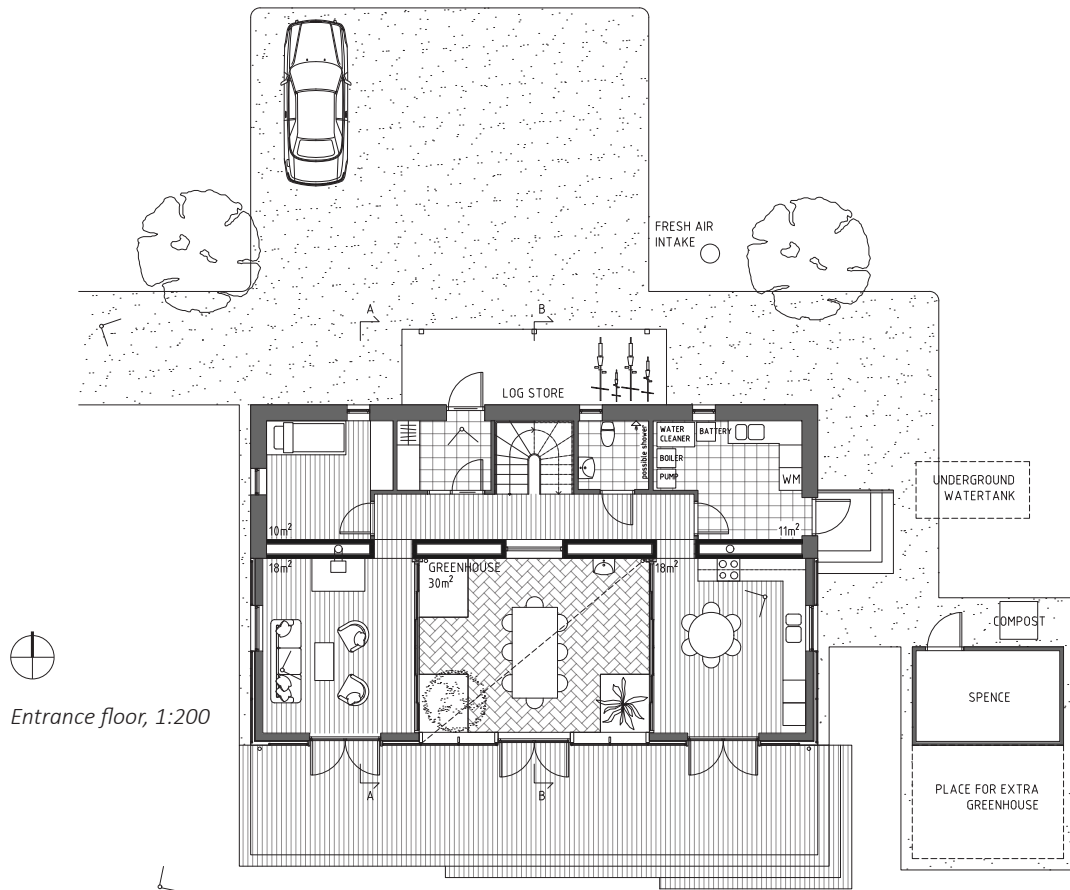

FACADES

The expression of the facades is similar to passive houses with most windows placed towards south, some towards west and east, and small ones on the northern side. The northern volume has a traditional wooden construction with proportions like a double cottage, flirting with surrounding buildings. On the southern side, the greenhouse construction continues outside the kitchen and living room, allowing an untreated CLT-construction behind. The roof angle is 30 degrees, allowing solar panels and solar collectors.



Facade towards south, 1:200

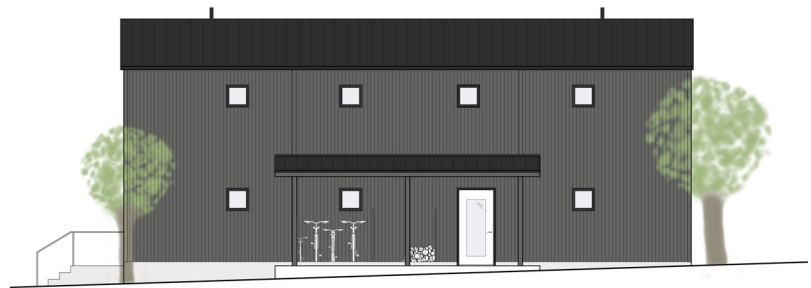

Facade towards north, 1:200

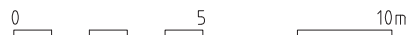

Rendering from northwest

15th May, 1pm



Facade towards west, 1:200



Facade towards east, 1:200

Wall - opening - ratio

	Facade	Windows	Doors
East	39,0	2,7	2,0
West	39,0	4,5	-
North	76,1	2,6	2,0
South	29,4	7,6	-
Totals	183,5	17,4	4,0

Windows: 9,5%

Doors and windows: 11,7%



Rendering from southwest

15th May, 1pm

SECTION

The construction has three layers: bricks, wood and glass. With thoughtful placement, they contribute to the heating of the indoor climate as well as the architectural expression. The bricks are placed as a massive core wall. The inspiration comes from traditional building techniques, having a chimney in the middle that helps heating the house. In this project the chimney is a longer wall, reaching from gable to gable. The glass lets sun through to the bricks, which then help heating the house. Another well tested solution for heating and cooling houses, implemented in the project, is to use the even temperature in the ground for supply air.

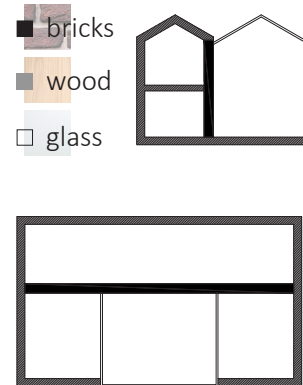

Rendering from the living room

15th May, 8pm

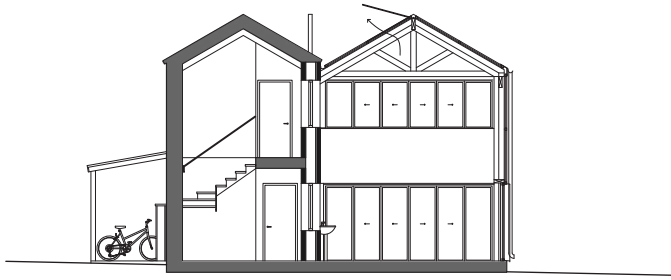

Section A-A, 1:200



Day water is gathered in gutters and brought down to an underground water tank through drainpipes. Gutters and pipes are embedded on both the roof and in the wooden panel, while the glass roof has exterior ones. Where the roof construction meets, the day water is brought down through pipes in the greenhouse.

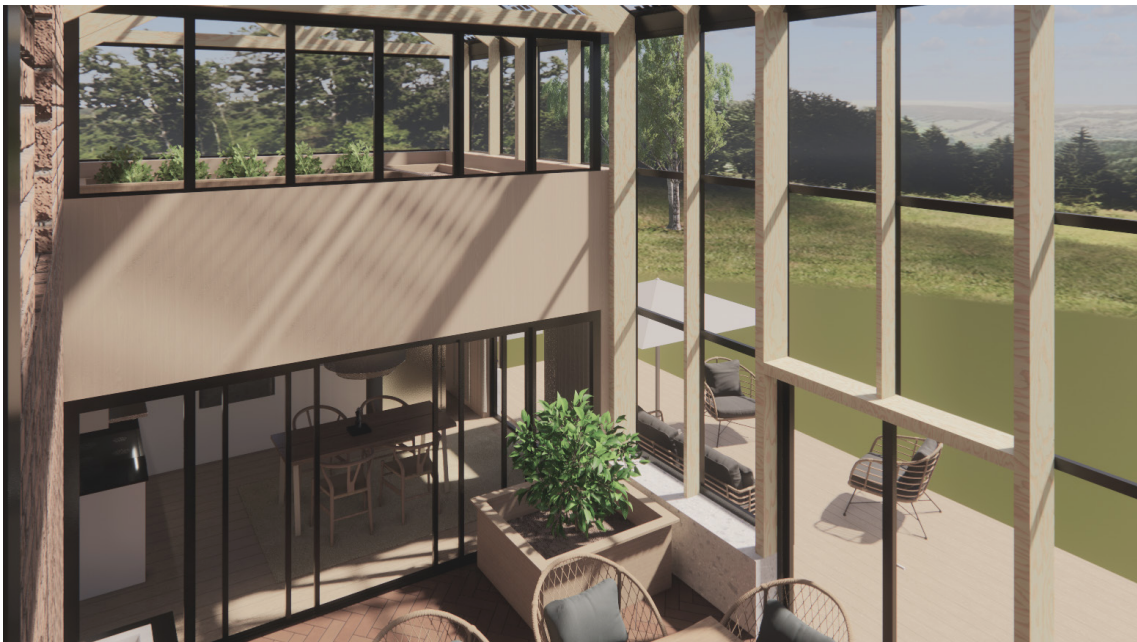

Rendering from one entresol

15th May, 1pm

DETAILS

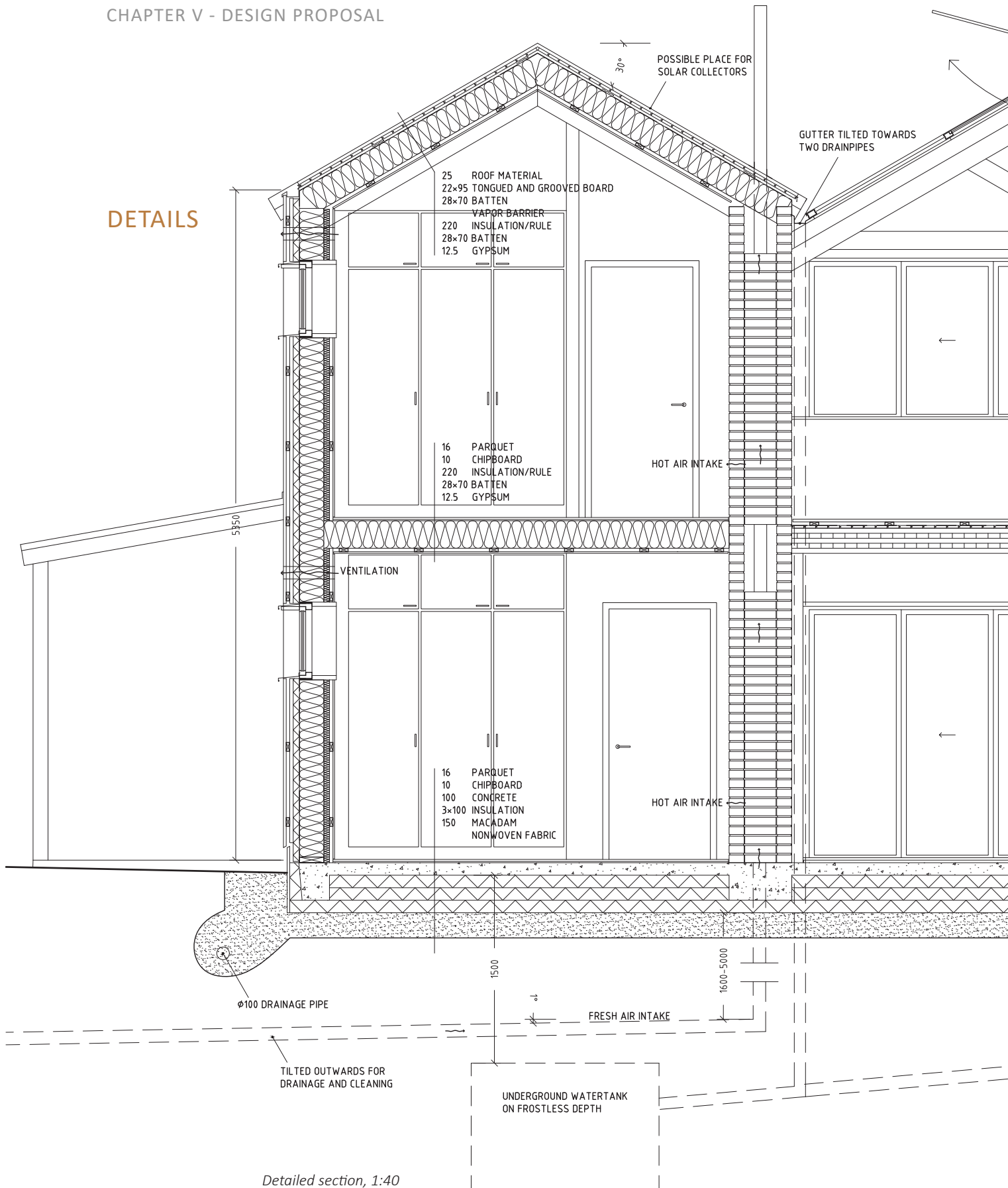

Detailed section, 1:40

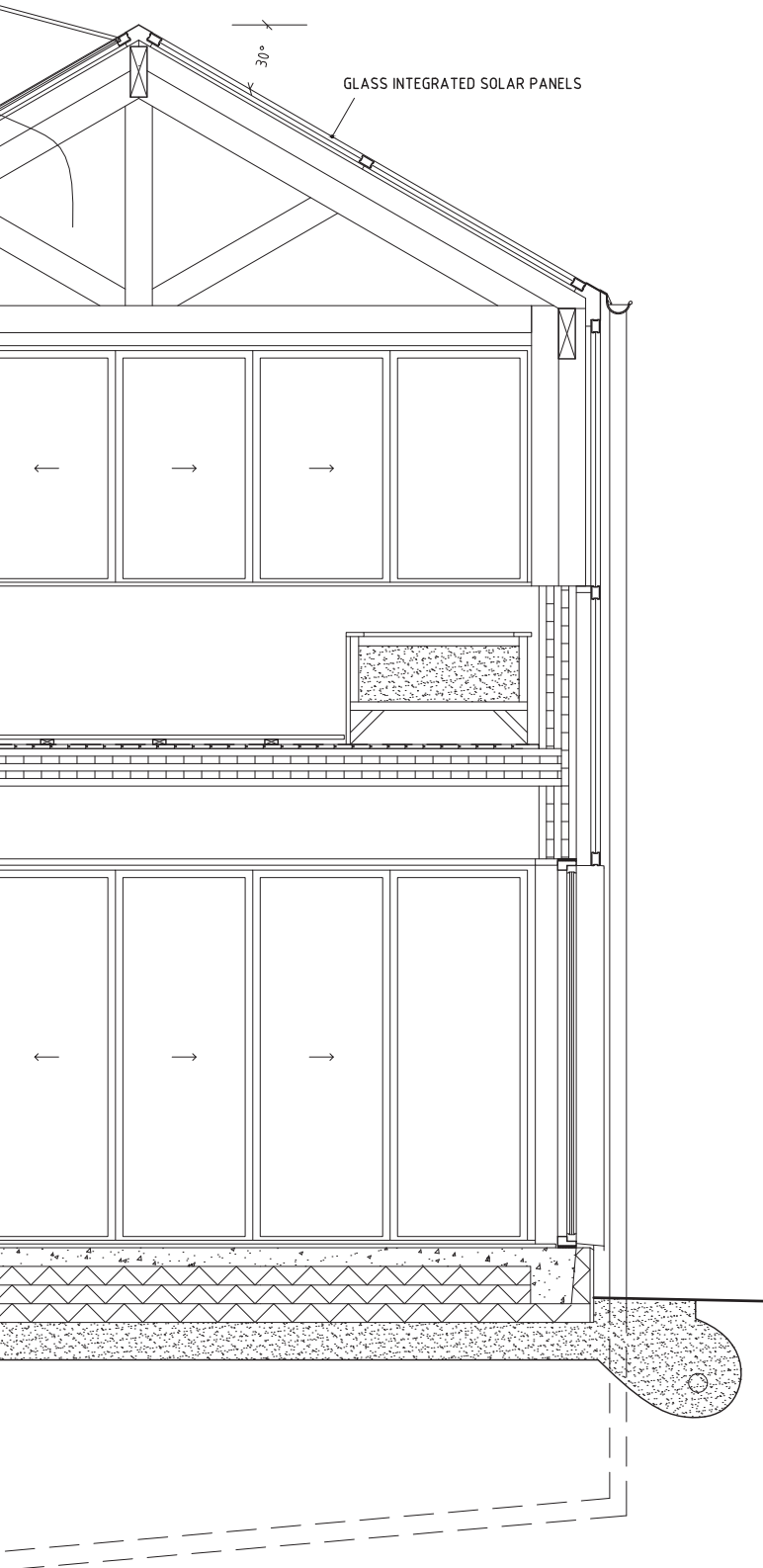

CHAPTER V - DESIGN PROPOSAL

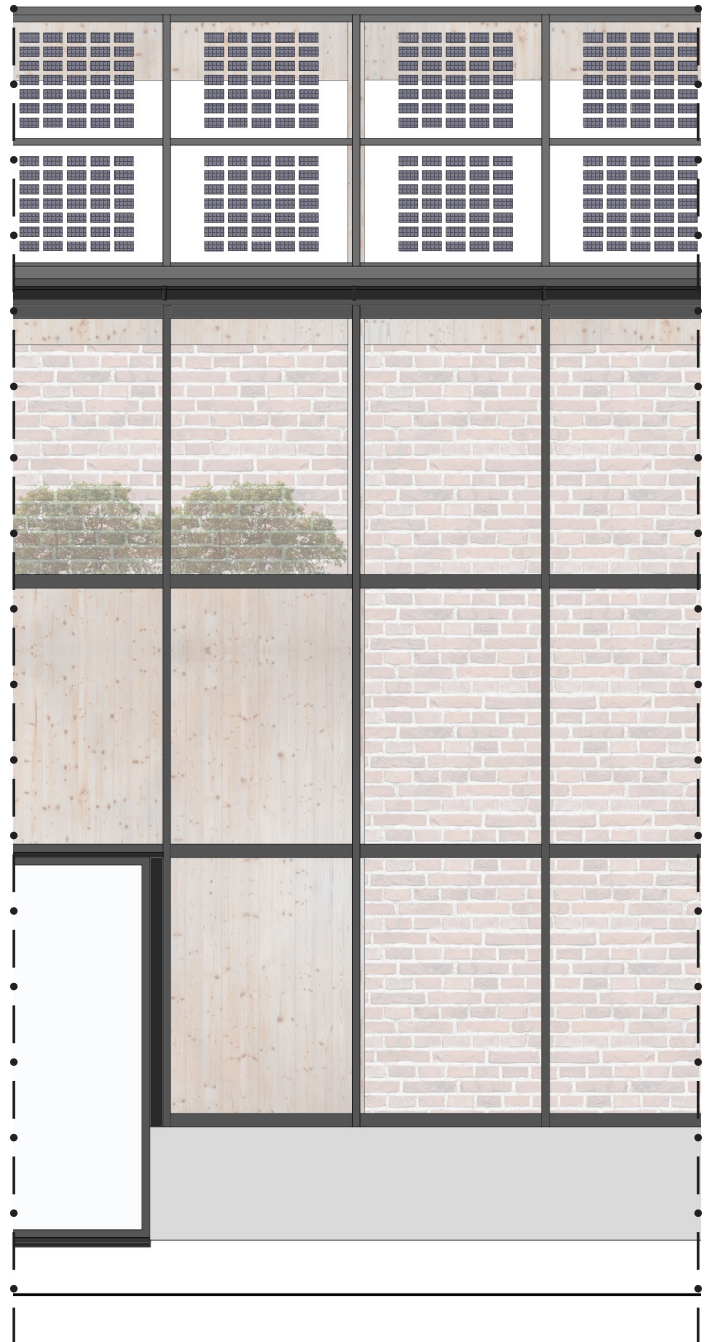

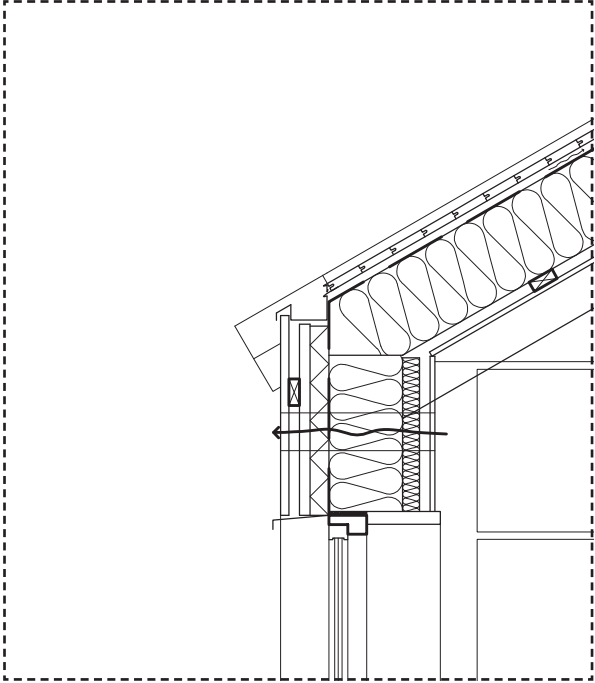

Roof construction, 1:20

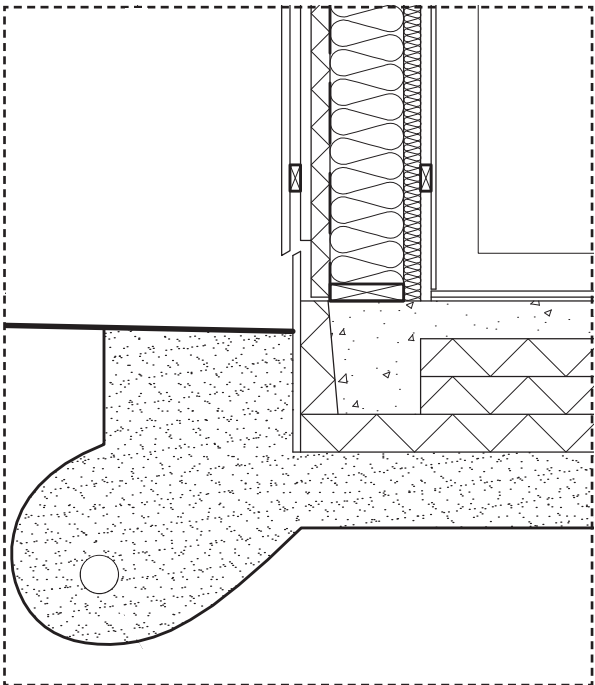
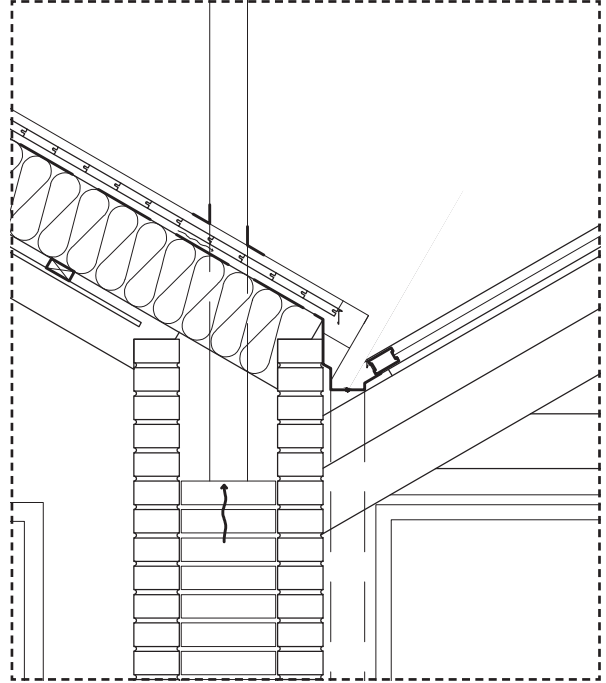

Ground construction, 1:20

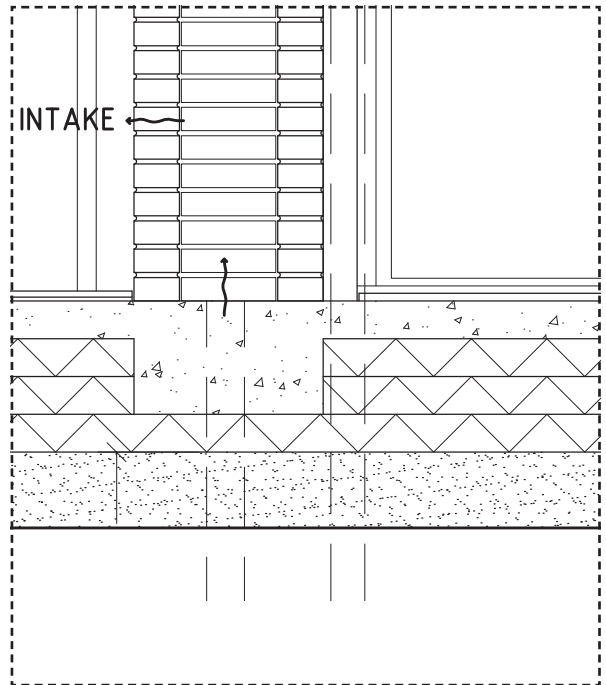

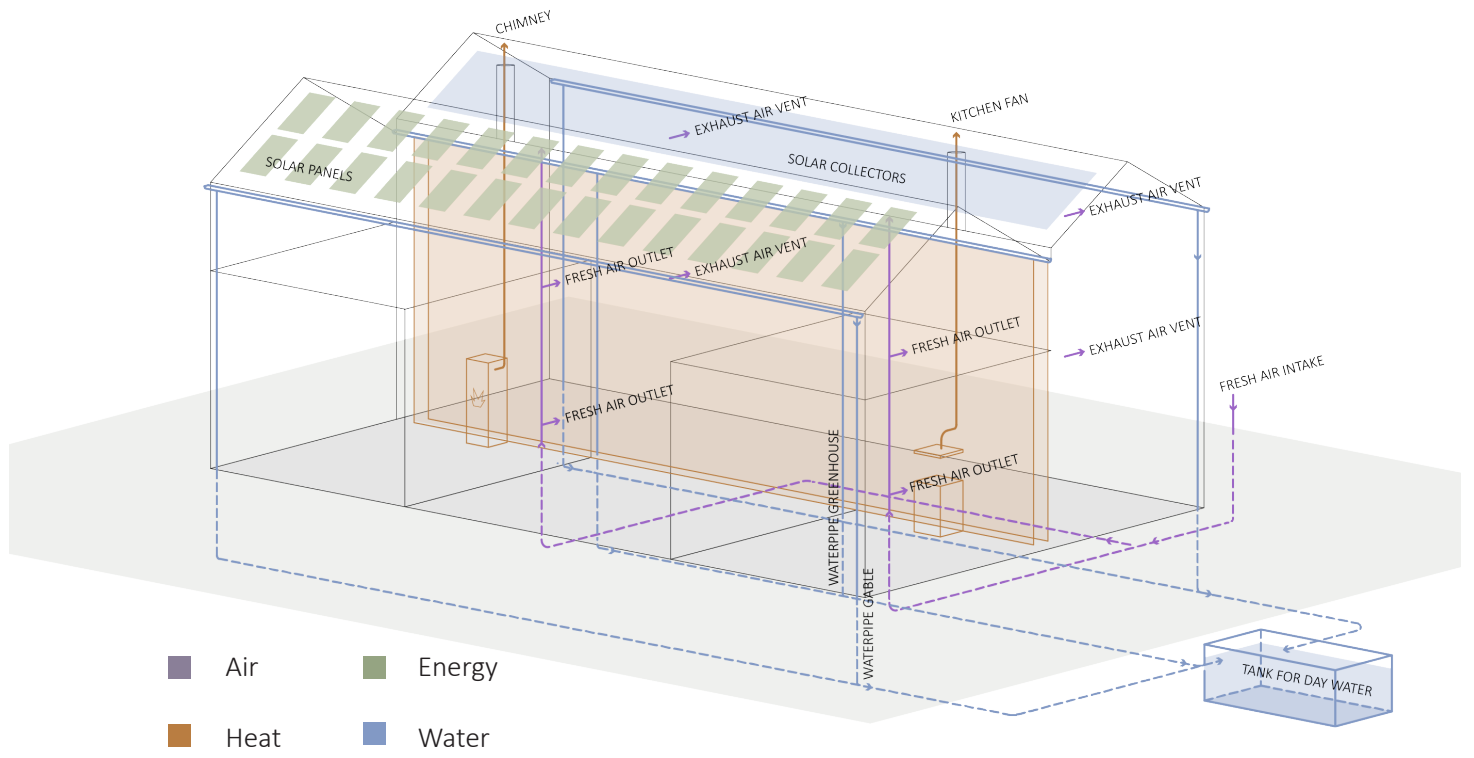

Diagram showing systems in the house

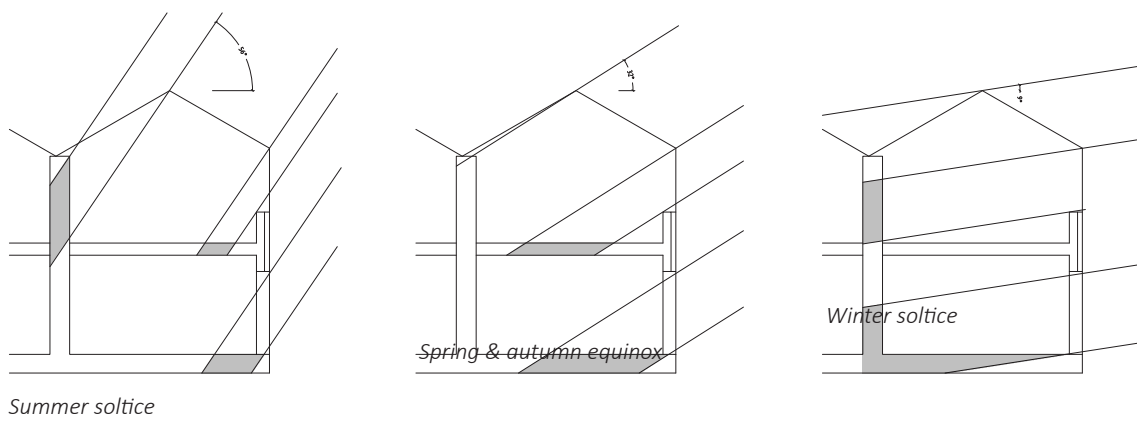
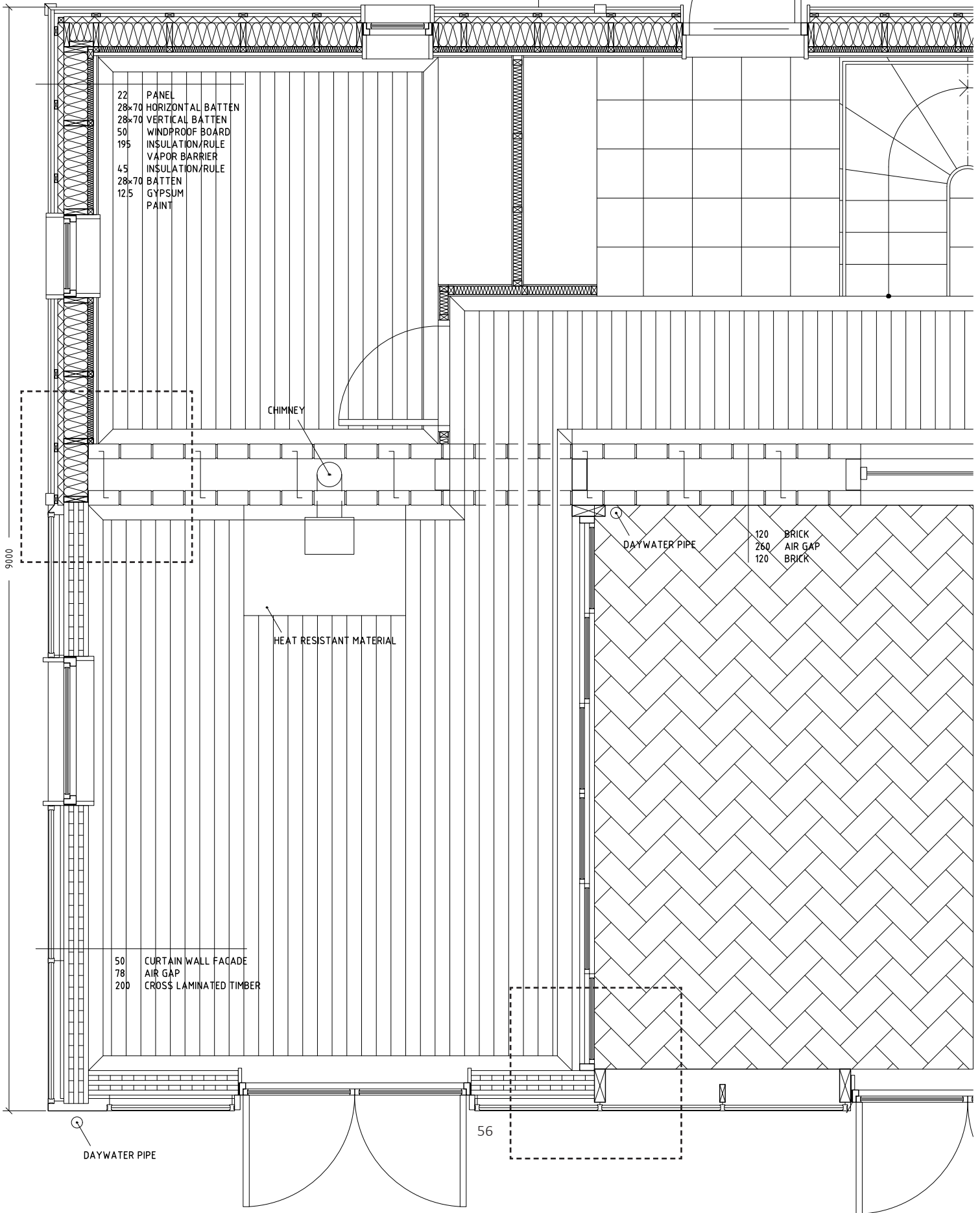
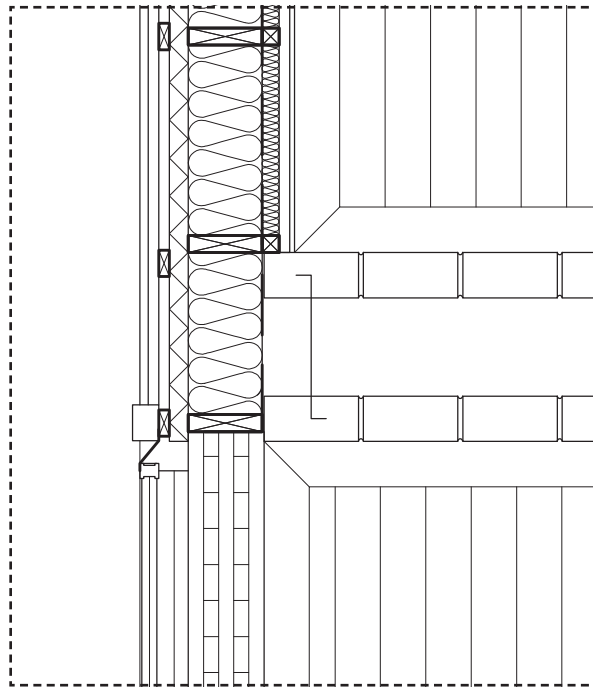

Diagram showing where the sun hits during different seasons

CHAPTER V - DESIGN PROPOSAL

Detailed plan, 1:40





1:20

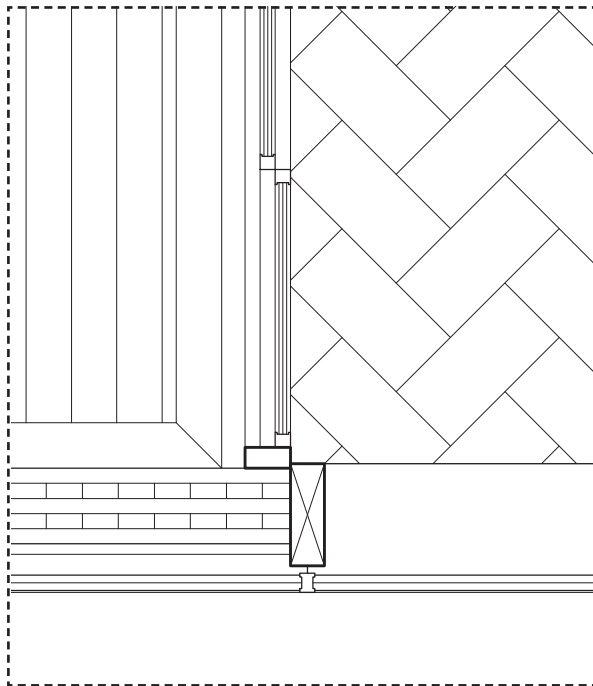

1:20

DISCUSSION

THE PROCESS

The process started with choosing a site for testing out my proposal. The choice of site is mostly based on how open it was and thereby how much sunlight it gets, as many of the design strategies benefits from using the sun. In addition to that one could also argue that a site nearby water is desirably to power the house with water energy as a complement to solar panels. When the sun is shining there is usually less wind and the other way around. By so, they can complement each other good.

The choice of site also affects how to handle sewage water. If the house is built inside a municipal detailed plan, it is often required to connect to their water- and sewage system. Even if the house is connected to the municipal water system it is possible to reuse nutrients, especially from the grey water. If the house is built on a site without municipal water, the owner is responsible for both getting fresh water and handle sewage. Reusing just greywater, or both grey- and black water, results in totally different

amounts of nutrients and therefore supplies different sizes of farmland. Luckily, it is more common that a plot outside municipal water is bigger than plots inside. Consequently, there are good circumstances to adapt the farmland to the volume of nutrients. If reusing the sewage, it probably also reduces how many times a year the sewage tank needs to be emptied. This master thesis is done on a site with no detailed plan, the reason it is complimented with an extra greenhouse.

One thing opposing the possibilities of handling water locally is Swedish laws. Even if the sewage water is cleaned enough for drinking once again, it is not allowed, according to the experiences from the project in Helsingborg. Probably, the law is there to protect the health of Swedes and for not putting more facilities on the responsibility of the municipality. One solution could be a certified facility possible for neighbors to use for having a local water cycle.

1st sketch: The horizontal

The design phase started by using the building program to arrange the different functions in a floorplan layout. By merging the functions more playful and less strict to the program, seeing it more as a guideline, the process started getting forward. One key was to try a version where the greenhouse was merged with the workshop, and sometimes even the wood storage. Those spaces can be colder, and the workshop was programmed for being a working area, helping the greenhouse.

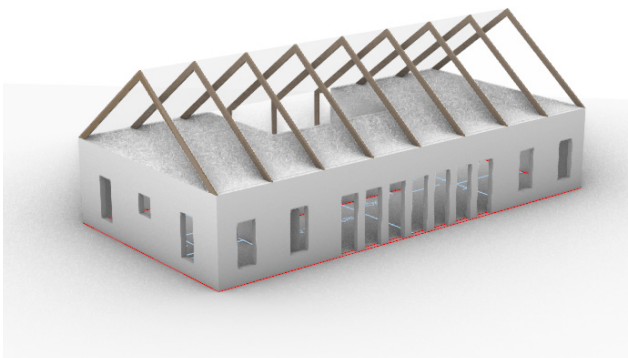
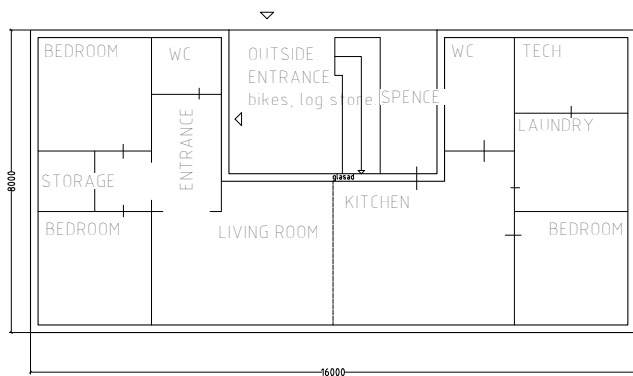
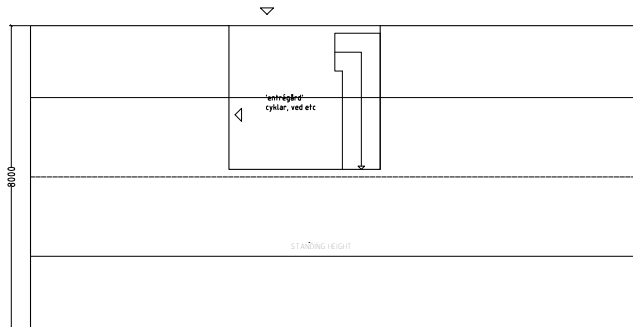

One of the first sketches was similar to Anki's nature house, all living functions on the first floor and a greenhouse on top as it automatically gets a lot of sun having it there and the footprint of the building gets smaller. A good thing with this proposal was the entrance garden towards north, where it was possible to store bikes and have a cold spence.

2nd sketch: The vertical

After some further research it seemed important to have at least two stories, for energy efficiency. At the same time the relationship between preferred temperature of different rooms was found. This was the reason for testing to stack the functions on top of each other in several stories, also here with the greenhouse on top. As warm air raises, the coldest room is placed in the basement and hottest in the upper floor. The concept generated a too high volume and therefore extensions was added on both sides to lower the building height. But the extra space was not required in the building program and the extensions were removed on the first floor. Instead, the idea was to use the overhang for summer shading on the south side and to create a sheltered entrance on the north side, but also as balconies buffering heat. The disadvantage was that only having the greenhouse on top takes away the opportunity to experience a greenhouse in different levels as the climate differs.



Figure 15 from page 27

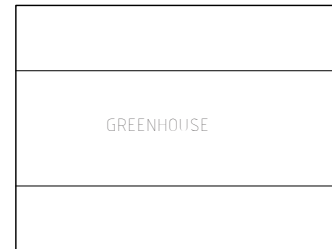

Top floor

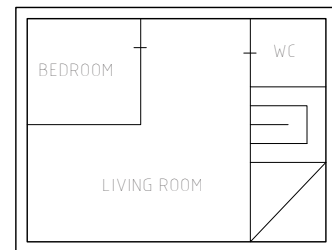

Second floor

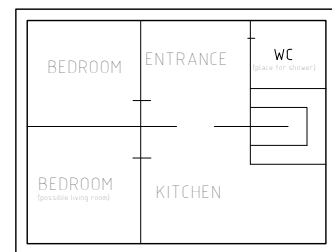

Entrance floor

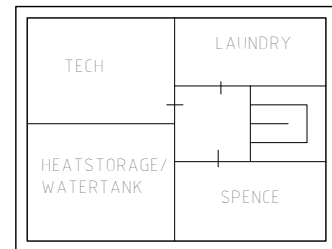

Basement

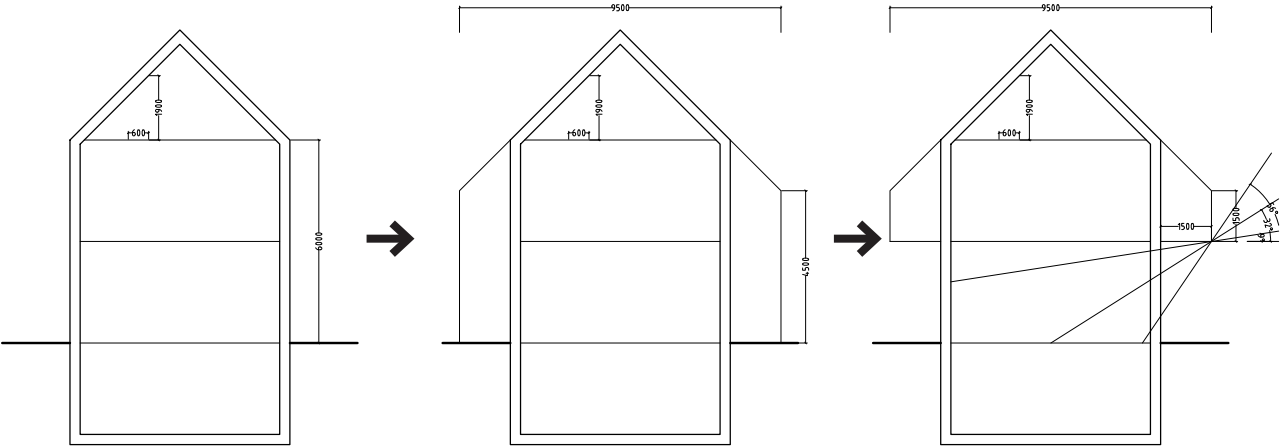

3rd sketch: Two stories

After the first two sketches the work with the final proposal started. Before this, the idea was to have the massive materials along the facades, like a Tromb wall, but no references was found where it was done in Nordic climate. Instead, the massive material was moved to the middle of the house. Putting it as a core wall hopefully better adapts to colder climates. It also contributes to the experience of the different rooms and moving between them, trough the brick wall.

One of the initial thoughts was to make it as a prototype house, possible to place on many

different locations. A common requirement in detail plans is a limitation of building height at 4,5 meters. This was a demand on the project until here, but it became a limitation obstructing good architecture. The ceiling height was too low on the second floor for especially the bathroom. The building height is also a bit a question of definition, partly where the base of the measurement should be if there for example is a terrace on one side, and partly because almost every plot has some kind of angle if it is not manually flattened. The reason this requirement was removed.

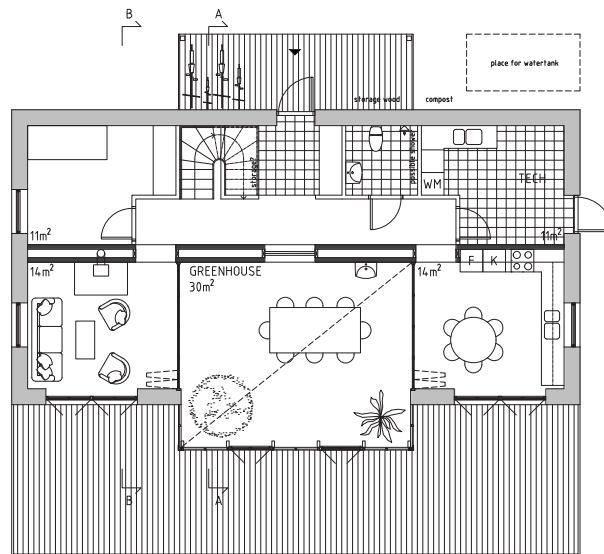

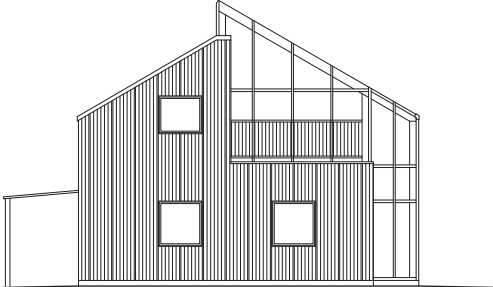
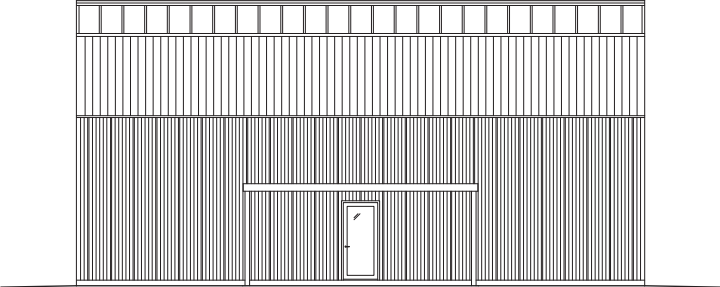
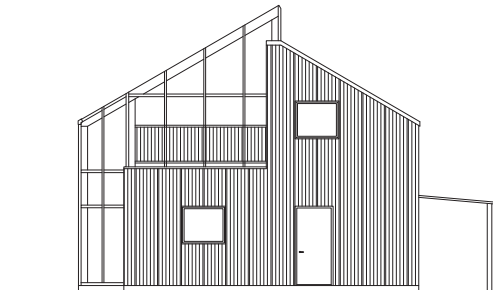
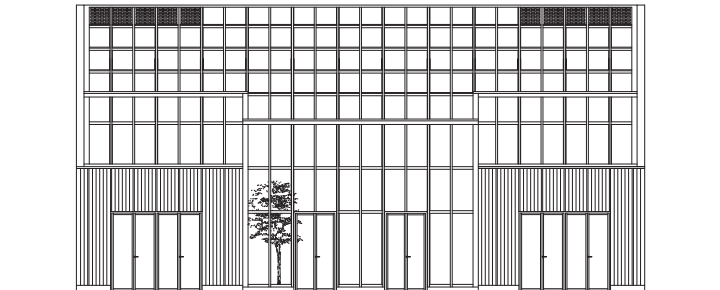

THE PROPOSAL

The final proposal has almost the same floorplan layout as previous sketch, but the exterior has got a new package, with a more clear gable picture, and a worked trough handling of the different components: bricks, wood and glass.

One can discuss how well the plan follows the design strategies. The toilets should then have been better placed along the core wall, as that is a warmer location. The challenge was then the communication zone along the northern facade became so long. Also, the other functions such as the staircase, the storage and the laundry suit this side well, so it is a compromise. As the toilets have its location along a facade it was then an opportunity to have a smaller window allowing to ventilate the room. Even the bedrooms and the laundry room have got smaller windows towards north to vent the rooms and create natural ventilation.

Windows on the northern facade can be discussed. If the building should stick to passive house principles it should have few or no windows towards north, as there is no sun to gain from there. In contrast to that older building traditions puts windows on both sides for natural ventilation, and probably also to get light in if the house has no electricity. As the house is going to be as self-sufficient as possible, without several mechanical solutions, the decision is to have windows towards north.

The core wall is containing two brick layers and an air gap between, and the thought is that it should be able to heat the house. One issue is that it is hard to evaluate this type of houses because the system is complex. Even people skilled in using simulation tools witness about simulations getting a too big error margin to provide trust.

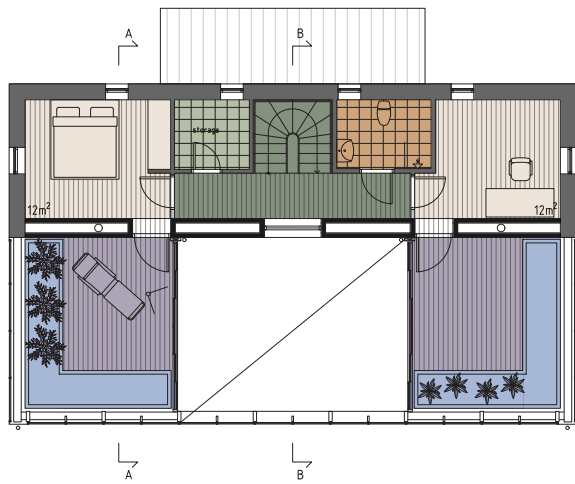
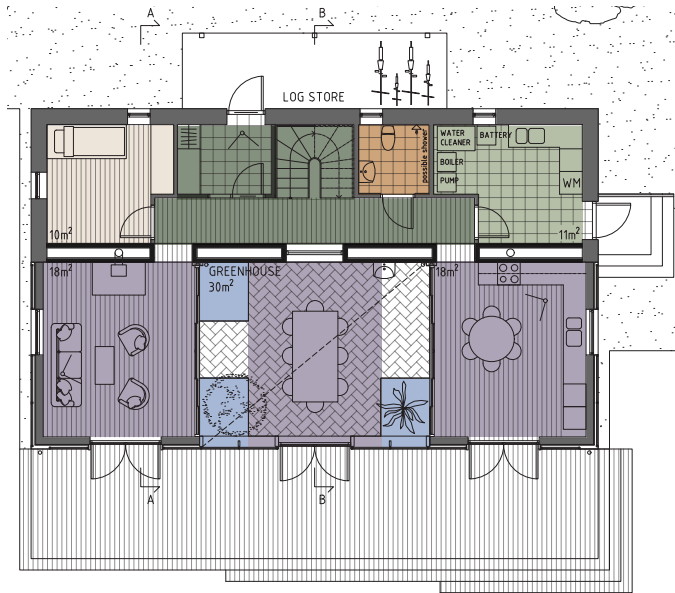

Program analysis

Room	Area	References		Master thesis proposals		
		Ankis nature house	Villa Idun-Lee	The horizontal	The vertical	The final proposal
■ Kitchen + dining + livingroom		70	87	68	48	64
■ Bathroom		9	7	8	7	8
■ Bedroom + office		20	28	27	26	34
■ Communication + hallway		14	22	12	35	30
■ Storage + tech		16	3	23	38	14
■ Farming		25		31	9	22

CONCLUSION

It has also been a question about how extreme the lifestyle happening in the house should be, or if should adapt to a wider target group, nudging those who did not thought about living in this kind of home initially. There were thoughts about making it an off-grid solution, not connecting it to national energy system. But that would require calculations of how much power the house needs, and how to best match it with solar panels, wind turbines etc. As it is a thesis in architecture the decision was to have it connected. Instead, the building design allows solar panels, by ensure a roof towards south angled good for solar power.

In this thesis the project is a single-family house, which is sometimes criticized as unsustainable as it takes so much land and resources to just create one home. At the same time villa areas usually have stronger social sustainability. When crisis arises, we tend to rather invest in a piece of land instead of having a large monetary asset on the bank, so the project is somehow an answer to how we usually respond to crisis. Having an own plot gives better conditions for being self-sufficient. A continuing project could have been to try put several units together,

sharing some functions such as a greenhouse and produce for example electricity together. Then the units can be smaller, requiring less building materials to make. The project would then rather be to investigate how to place the units together, which functions that can be merged and how it affects a possible life there. Sharing is usually a good way for being more sustainable, but there is always a tricky question of responsibility that needs to be solved.

The purpose of the thesis was to investigate design strategies for architects and test them out in a project. The proposal of the thesis could have gained from doing more study visits to get more perspective and interviews on the experience of living in those kinds of houses. Nevertheless, the master thesis has given knowledge about how to treat a building volume, facade expression, floorplan layout and choice of material with a specific target in mind: how to make building design and its materials contribute to resilient architecture, utilizing resources from nature. A house that takes a step towards self-sufficiency and architecture supporting its inhabitants if a crisis occurs.

*Thank you for reading my master thesis!
I hope you found it inspiring and interesting.*

*All the best,
Sandra*

BIBLIOGRAPHY

LITERATURE

Alpman, M. (2022). Dags att ta vara på vattnet i avloppet. *Forskning Framsteg*. (nr 6), 28-33.

Bradbury, D. (2019). *Off the grid - Houses for Escape*. Thames & Hudson.

Combi Heat Värmeprodukter. (2023, September 21st). *Kombinera solångare med ackumulatortank*. <https://www.combiheat.se/info/kombinera-solfangare-med-ackumulatortank/>

Day, C. (2016). *The Eco-Home Design Guide*. Cambridge: Green Books.

E.ON, e. (2024, January 16th). *Vad är lokala energisystem?* Hämtat från E.ON: <https://www.eon.se/om-e-on/innovation/lokala-energisystem/vad-aer-lokala-energisystem>

European Union. (n.d). *Waste Framework Directive*. Environment: https://environment.ec.europa.eu/topics/waste-and-recycling/waste-framework-directive_en

Gameau, D. (Regissör). (2019). *2040* [Film].

Granmar, M. (2021). *Naturhus - bygg, bo och odla för en hållbar framtid* [Nature house- build, live and farm for a sustainable future]. Natur & Kultur.

Grygierek, K., & Ferdyn-Grygierek, J. (2022, November 12th). Design of Ventilation Systems in a Single-Family House in Terms of Heating Demand and Indoor Environment Quality. *Energies*, 15, 8456. <https://doi.org/10.3390/>.

Gullbring, L. (2022, January 28th). *Kretsloppsanpassat hus i hus - Ankis Naturhus*. <https://www.byggahus.se/kretsloppsanpassat-hus-i-hus-ankis-naturhus>

Hagelberg, L., Henriksson, P., & Lindberg, J. (2022). *Arkitektens roll på landsbygden - en förstudie om urban norm och rurala alternativ*. <https://rurark.se/forskning:RURARK>.

IVA. (2021). *Klimatförändringar och hållbar vattenförsörjning* [Climate changes and sustainable water supply]. Kungl. Ingenjörsvetenskapsakademien.

Kachadorian, J. (2006). *The passive solar house*. Chelsea green publishing.

- Krisinformation. (2023, February 2nd). *Energiläget*. <https://www.krisinformation.se/energilaget>
- Linton, S. (2020, October 12th). *Nära-nollenergibyggnader*. <https://www.energimyndigheten.se/energieffektivisering/program-och-uppdrag/nara-nollenergibyggnader/>
- Löfgren, S., & Ylenfors, I. (2023). *A nudging home*. Gothenburg: Chalmers.
- Nicholls, L., Strengers, Y., & Sadowski, J. (March 2020). *Social impacts and control in the smart home*. *Nature Energy*, ss. Vol 5, 180-182.
- Nordström, N. (2024, March 7th). *Regeringens satsning på småhus får kritik*. <https://arkitekten.se/nyheter/regeringens-satsning-pa-smahus-far-kritik/>
- Passivhuscentrum. (n.d). *Passivhus*. <https://www.passivhuscentrum.se/passivhus/>
- Rahm, P. (2023). *Climatic architecture*. Actar Publishers.
- Svensk trä. (n.d). *Villa Idun-Lee*. <https://www.svensktra.se/inspiration/trapriset/trapriset-2020/villa-idun-lee/>
- Söder, L. (2021, August 16th). *Småhusområden skapar social hållbarhet*. <https://www.bostadspolitik.se/2021/08/16/smahusomraden-skapar-social-hallbarhet/>
- Tailormade Architects. (2023, September 21st). *Ankis Naturhus*. <https://www.tailor-made.se/anki-greenhouse>
- Warne, B. (1993). *Naturhuset*. In *På akacians villkor - att bygga och bo i samklang med naturen* [On acacias condition- to build and live in harmony with the nature] (p. 13-33). Warne Förlag.
- YR Architecture Design. (n.d). *An intro to solar orientation*. <https://yr-architecture.com/an-intro-to-solar-orientation/>

BUILT REFERENCES

Olson, F. G. (2021). Ankis Naturhus. Ljungbyhed, Skåne.

Nadén, P. Kolbe, A. Von Friesen, A. Vaccino, M. (2016). Villa Idun-Lee. Saltsjö-Boo, Stockholm.

PICTURES, FIGURES & TABLES

All figures are made by myself and all pictures without source are taken by myself. I have got permission for using the following pictures in the document.

Nadén, P. (2016). *Front window* [photograph]. Villa Idun-Lee.
<https://antonkolbe.se/idun-lee>

Nadén, P. (2016). *Exterior* [photograph]. Villa Idun-Lee.
<https://antonkolbe.se/idun-lee>

Nadén, P. (2016). *Interior* [photograph]. Villa Idun-Lee.
<https://antonkolbe.se/idun-lee>

Nadén, P. (2016). *Floorplan and section* [drawings]. Villa Idun-Lee.
<https://antonkolbe.se/idun-lee>

Tailormade Arkitekter (2021). *Floorplan and section* [drawings]. Ankis Naturhus.
<https://www.tailor-made.se/anki-greenhouse>



Master's Thesis in Architecture