

THE STRAW PROJECT

Urban re-densification with low impact- & residual materials



- Exploring the use of prefabricated straw walls for housing in an urban, Nordic context

*Jessica Börjesson
Master Thesis 2024*

*Examiner: Paula Femenias
Supervisor: Walter Unterrainer*

*Chalmers School of Architecture
Department of Architecture and Civil Engineering*



CHALMERS
UNIVERSITY OF TECHNOLOGY

THE STRAW PROJECT

Jessica Börjesson

Master Thesis 2024

Examiner: Paula Femenias

Supervisor: Walter Unterrainer

Chalmers School of Architecture
Department of Architecture and Civil Engineering
Architecture and Planning Beyond Sustainability

ABSTRACT

When “business as usual” and the untenable amount of resource extraction and CO₂ emissions within the building industry is no longer an option if we are to have any chance of reaching the SDGs and turn the critical climate development, we need to seek for other sources to resources.

The context of the thesis is the urgent need to counteract climate change and make a transition to a more sustainable use of resources, energy and space as well as answering to the housing situation in Gothenburg. Statistics shows an increasing influx of inhabitants concentrated to the metropolitan area with steadily growing housing queues and the estimated population growth until 2040 is +120 000 inhabitants.

The focus of the thesis has therefore been to explore how upcycling of residual straw from the agriculture and other natural, low-impact materials can play an important role in this transition together with strategies for sustainable urban re-densification. By focusing on prefabrication techniques for straw wall elements the traditional material meets modern housing standards and the efficiency required on an urban construction site.

The design proposal acts as a pilot project and a testbed for all the research and explorations gathered throughout this process. It displays aesthetic and architectural possibilities of the materials and highlights the paradigm shift needed within the building industry by reducing CO₂ emissions, resource extraction, land exploitation and energy use through its significantly reduced environmental impact compared to conventional building materials and sequestration of about 76 tons of CO₂. The result is a 4-storey residential building on an infill-site in the urban setting of Gothenburg, adding a new layer in the cityscape that tells us how we, by questioning and breaking conventions, shifted to a more long-term sustainable use of resources.

Keyword: Straw, Low-impact materials, Urban re-densification, Vertical extension, Infill, Renewable materials, Circular economy, Upcycling, Prefabrication

“ *Reducing embodied carbon in building materials to net zero is achievable by 2060, if we promote the development and use of best available technologies for decarbonising conventional materials, combined with a major push to advance the increased use of regenerative, circular biomaterials from forest and agriculture streams.* ”

(UNEP, 2023, p.10)

AUTHOR

STUDENT BACKGROUND

BACHELOR

KTH- Royal Institute of Technology, Stockholm
B.Sc. in Architecture 2018-2021

PRACTICE

Internship at Kaminsky Architecture, Stockholm
2021-2022

MASTER

Chalmers University of Technology, Gothenburg
Master Program: Architecture and Planning
Beyond Sustainability
M.Sc. in Architecture 2022-2024



Contact:
Jessica Börjesson
jessicaborjesson@live.se

Thank you!

Walter Unterrainer for your valuable knowledge, support and guidance throughout this whole process

Paula Femenias for your support, encouragement and feedback throughout the thesis work

Torsten Lendt for your generosity in sharing your valuable knowledge and inviting me to your production in Tidaholm

Jenny Nyström for sharing your knowledge with me and discussing my thesis topics

Paul Lynch/EcoCocon for providing me with a straw module and valuable knowledge about prefab straw panels

Alexander Hollberg for supporting me with technical questions regarding the LCA

Dear family & friends who has unconditionally supported me and cheered for me throughout the whole time

This wouldn't have been either possible or as enjoyable without you!

TABLE OF CONTENTS

<i>Abstract</i>	I
<i>Student background</i>	II
<i>Acknowledgment</i>	III
Chapter 1: Introduction	I
<i>Background & discourse</i>	I
<i>Purpose and exploration of straw</i>	5
<i>Thesis questions</i>	6
<i>Delimitations & Focus, glossary</i>	7
<i>Method</i>	8
Chapter 2: Material knowledge	11
<i>Low-impact materials: The importance of material choices</i>	11
<i>Theory & preconditions - straw</i>	12
<i>The straw module</i>	15
<i>Study visit: Swedish prefab straw producer</i>	20
<i>Case studies- reference projects</i>	22
Chapter 3: Design project	25
<i>Context of the project: site & analysis</i>	25
<i>Program</i>	34
<i>Spatial intervention strategies</i>	35
<i>Design principles</i>	36
<i>Architectural explorations: process</i>	37
<i>Final building design</i>	40
<i>Material discussion</i>	54
<i>Daylight analysis of the final design</i>	56
<i>Environmental impact of the final design</i>	58
Chapter 4: Discussion & references	63
<i>Discussion & Conclusion</i>	63
<i>List of references</i>	66
Appendix	68

1.

INTRODUCTION

- Background & discourse
- Purpose & exploration of straw
- Thesis questions
- Delimitations & focus, glossary
- Method

BACKGROUND & DISCOURSE

EMISSIONS IN THE BUILDING SECTOR AND A CALL FOR NEW STRATEGIES:

The context and focus of the thesis is the urgent need to counteract climate change and make the transition to a more sustainable use of energy, resources and space as well as answering to the housing situation in Gothenburg, confronting an increasing influx of inhabitants concentrated to the metropolitan area with growing housing queues.

In The sustainable development goals report (UN, 2022) it's stated that global greenhouse gas emissions are currently estimated to increase by almost 14% until 2030, instead of what's needed: a peak in global gas emissions before 2025 and a decline by 2030 of 43% before reaching net zero in 2050.

The urgency in starting to respect the planetary boundaries and work towards a transition to low-impact materials within the building sector is evident in the report 'Building materials and the climate: constructing a New Future' (United Nations Environment Programme [UNEP], 2023) which presents that as much as 37% of the global greenhouse gases is emitted from the building sector, making it undoubtedly the largest contributor. A significant carbon footprint comes from producing and using materials like steel, aluminum and cement. The focus

has up until now been to reduce the operational carbon whereas the main part of potential emissions to cut now can be found in the embodied carbon, i.e. how we construct buildings and for what purpose. There has been a shift since the middle of the previous century when cities were still built mostly with renewable materials and old structures were reused for new projects. Now we need a shift again, towards an approach of regenerative use of materials. One of the three outlined important main paths & strategies to implement now is to:

"Shift to regenerative material practices wherever possible by using ethically-produced low carbon earth- and bio-based building materials (such as sustainably sourced bricks, timber, bamboo, agricultural and forest detritus) whenever possible." (p. 9)

An important task from now on is to rethink the way of designing, producing and choosing materials, or deselecting high-impact materials. Due to the increasing urbanization a shift towards regenerative methods for building material life-cycles is needed and this requires urgent policy actions (UNEP, 2023).

GLOBAL GREENHOUSE GAS EMISSIONS:

Source: The sustainable development goals report (UN, 2022)

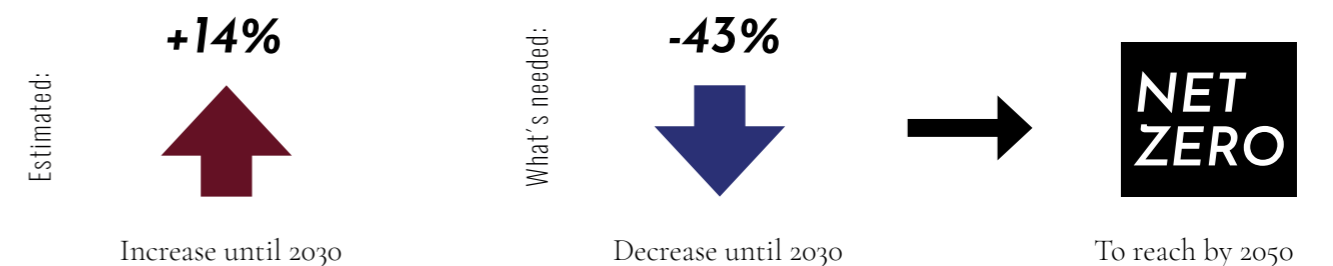

GLOBAL GREENHOUSE GAS EMISSIONS IN THE BUILDING SECTOR:

Source: Building materials and the climate: constructing a New Future (UNEP, 2023)

Largest contributing sector to global emissions with:

37%!

Main focus up until now:

Reduce:
Operational carbon

Main part of potential emissions to cut from now on & 3 outlined strategies:

Reduce:
Embodied carbon

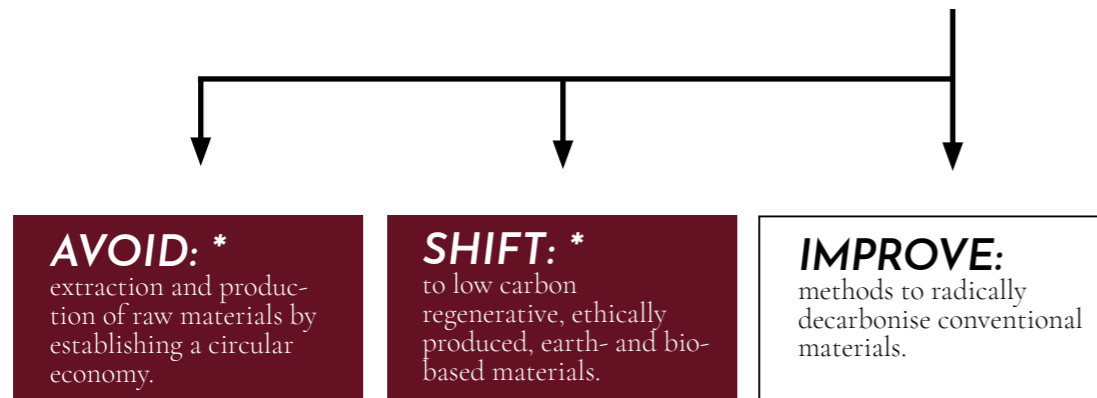

**This thesis is applying the two strategies “avoid” and “shift”.*

AVOIDING AND SHIFTING: WOOD VS. RESIDUAL STRAW

Aiming for “net zero” means, in contrast to, zero emissions, to compensate for unavoidable GHG emissions in a construction by employing carbon dioxide removal, i.e. negative emissions, through biobased materials. These materials are characterized by, through photosynthesis, removing carbon dioxide while its growth/ regrowth after harvesting the biomass. Wood, a relatively slow-growing bio-material, has to date been the most applied material for replacing GHG-intensive building structures, giving the benefits of both cutting off the emissions connected to concrete or steel production but also working as a carbon sink in the form of a building.

Potential risks connected to drastically expanding the use of wood in buildings is the consequence of reduced carbon sinks from forests, a phenomenon that’s been seen lately in Europe. Recent studies has shown that more efficient ways of replacing GHG-intensive materials can be achieved by using fast growing alternatives such as bamboo and straw which has a good carbon removal potential as well as reduced emissions during their life-cycle. The major difference between these and wood is their quick regrowth, giving a higher yield. As these are usually byproducts of croplands, the avoiding of land use competition between food production and building construction is an important advantage (Carcassi et al. 2022).

INHABITANT GROWTH AND HOUSING SUPPLY:

At the same time as the building industry is straining the planetary boundaries we’re facing the challenging situation in Sweden with a shortage of affordable housing and ever growing housing queues concentrated to the metropolitan regions. This, I would argue, means we must continue to generate housing but find new means to limit the pressure on the planetary boundaries such as transform existing, underutilized or obsolete parts of the building stock and when building new, materials should be reused or of a radical low-impact sort.

According to Gothenburg city’s status report “Lägesrapport 2022 bostadsförsörjning” (Fastighetskontoret, Göteborgs stad 2022) estimations show that Gothenburg’s population will continue to increase by 120 000 until 2040 and that the housing construction so far haven’t been sufficient to meet the continuous growth. The report also shows that newly-built apartments are significantly more expensive, where the annual average rent per m² for a 3-room apartment is 56% higher than for an equivalent apartment in the existing stock.

According to the survey “Bostadsmarknadsenkäten” from 2023 as much as 92% of the 13 municipalities in Greater Gothenburg (Storgöteborg) stated that they have a shortage of housing and near two-thirds of them indicate that high production costs is something that limits the housing constructions. (Boverket, 2023).

Preliminary data from SCB presented in Boverkets survey “Bostadsmarknadsenkäten” from 2024 shows that about 40% fewer housing constructions started in Gothenburg during 2023 than during 2022, and the prognosis for 2024 is that it will decrease further with about 35% compared to 2023 (Boverket, 2024).

FINDING NEW WAYS FORWARD:

This highlights the challenging and paradoxical situation with the need for a continued housing construction in the Swedish metropolitan areas which constantly expands, but increasing construction- and material costs is considered an obstacle and in the end many newly produced apartments become too expensive for those who actually need them. This is a larger societal and political matter specific to the Swedish context where for example social housing isn’t a model applied like in other European countries. The thesis will not focus on changing these political conditions, but rather focus on decreasing the environmental impact from the housing construction combined with a certain degree of sharing economy through shared facilities and resources to reduce the need for private owning.

92%

Of the municipalities in Storgöteborg state that they have a shortage of housing

40%

fewer housing constructions started in Gothenburg during 2023 compared to 2022

35%

fewer housing constructions are estimated to be started in Gothenburg during 2024 compared to 2023



We must continue to build housing, but start respecting the planetary boundaries by rethinking our material choices and take urgent actions.

WHY DENSIFY THE CITY, AND HOW?

The share of inhabitants living in metropolises is steadily growing around the globe which calls for strategies to deal with this development. Through re-densification we can utilize existing infrastructure and urban quarters and avoid splinter the development onto the landscape. Still, these strategies can also generate problems such as overload on existing public transport, increased air- and noise pollution and a concern for gentrification (Kramer 2018).

Gothenburg has a relatively low-rise city center with most of the buildings being between 3-5 stories high thus the city is already covered with large parts of non-permeable surfaces and buildings despite the low density. For that reason the green areas are of highest importance to keep in favor of biodiversity, water management, heat mitigation and recreation. Therefore urban re-densification combined with natural, low-impact materials is an interesting strategy to explore for future sustainable urban development and a chance to rethink unsustainable

building conventions.

Through vertical densification in "urban gaps" such as infill plots in the cityscape or on flat roofscapes the re-densification potential could be explored and alternative ways of developing the city in a low-impact and sustainable way manifested. For these preconditions it's a criteria to work with relatively lightweight materials.

Urban re-densification can arguably be a sustainable strategy applied in a balanced amount in order to save resources and prevent ground exploitation and biodiversity loss. Two important factors to look at when deciding is scale and cultural historical values to see which areas and quarters that can accommodate a denser built environment and for example how it affects and change the cityscape and light situations in every specific case which will be examined in the thesis. The illustration below shows different strategies of re-densification as well as a hybrid situation which is the case in this project & site.

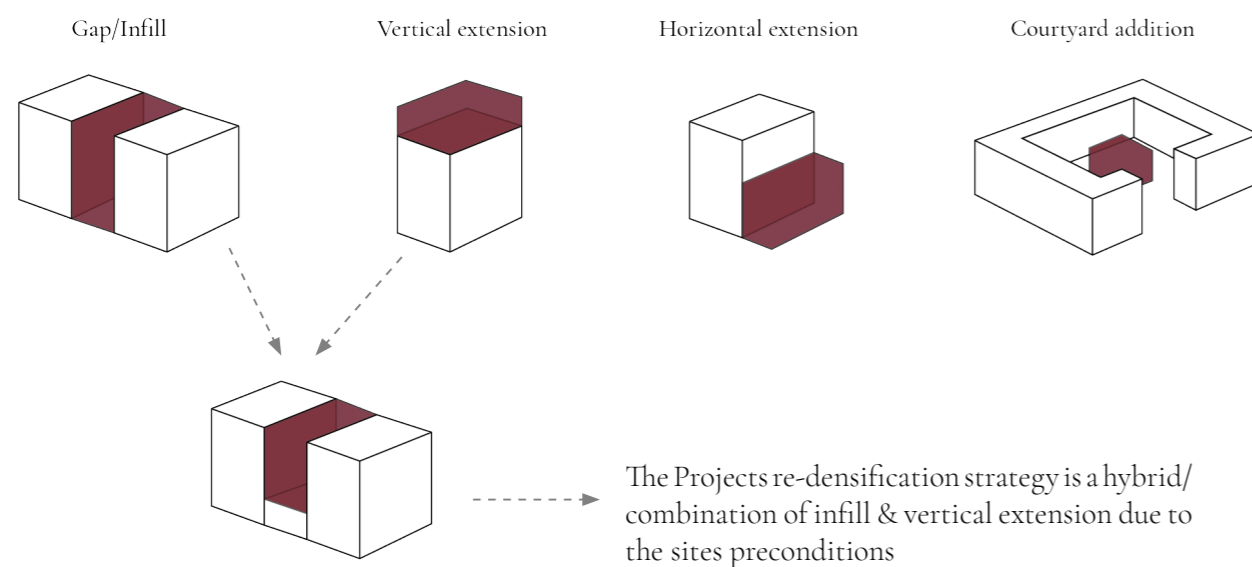

Figure 1: Illustration of urban re-densification strategies

PURPOSE & EXPLORATION OF STRAW

Straw is often considered an old-fashioned material solely for private homes in rural areas, in developing countries or in warmer climates and made by self-builders or grass-root initiatives. What have been examined through this thesis is how it could also be a viable material for buildings in a colder, Nordic climate, and in an urban context. The aim has been to explore new contexts and scales where it could have the possibility to generate an even larger positive impact for future urban development. Except from the theoretical and practical material explorations itself, this thesis have used the final design project as a test bed for the design possibilities and environmental impact of the materials.

-Pilot project'

The aim of the design project have been to explore and showcase the potential of natural/residual materials and display it in a centrally located building in the urban context. To raise awareness, curiosity and develop knowledge within the field of low-impact architecture have been an important aspect of it. By revealing challenges and opportunities connected to building with straw in the Nordic, urban context, some questions/obstacles in relation to current building regulations/policy's and site specific preconditions have been identified but have nevertheless been considered as important learning and knowledge generation along the way.

THESIS QUESTIONS

1. *How can residual straw be used for housing construction on an urban infill site to support a circular economy and counteract the current unsustainable resource use & CO₂ emissions?*
2. *How can this specific infill site with occupied ground floor be transformed to enable housing and thereby support the vitality of the area?*

SUB-QUESTIONS

- What are the design related constraints and possibilities building with prefabricated straw-elements?
- What other natural, low impact materials can complement the building as viable construction materials to support these goals?

DELIMITATIONS & FOCUS

//DEFINING WHAT THE THESIS:

WILL

- Build on existing knowledge and emerging technical development of prefabricated straw-modules .
- Examine the possibilities building with straw and complementary low-impact bio-based materials in an Nordic urban context.
- Examine urban redensification and land-saving through an infill strategy.
- Use existing research and examples to identify strategies for the implementation of a straw-based structure in the Nordic context.
- Be material focused: explore low-impact materials, their properties and qualities in relation to aesthetics and design.
- Focus on ecological sustainability and reduction of CO₂ emissions as well as energy-/ resource use and use a LCA tool to measure and analyze the impact of the design.

WILL NOT

- Specifically aim to generate new knowledge in terms of technical development of the prefabricated straw bale modules.
- Examine or propose self-building with straw or other materials.
- Focus on the technique of manual, on site-straw bale building which is too labor and time consuming in a larger implementation and in an urban context.
- Constrain the architectural design to fully comply with all provisions in the current detail plan.
- Focus primary on economic aspects or aim to solve the shortage of affordable housing nor execute comprehensive economical calculations.
- Focus on optimizing technical systems in the building as a part of the strategy to decrease the impact of the building.

GLOSSARY

- SDG - Sustainable development goals
- LCA - Life cycle assessment
- GWP- Global warming potential
- GHG- Greenhouse gases
- CDIR- Carbon dioxide intensity ratio
- SOM- Soil organic matter

METHOD

RESEARCH METHODS

Throughout this thesis a mixed method research has been employed, combining quantitative and qualitative research approaches to achieve a comprehensive understanding of the research problem and to obtain optimal results.

Qualitative data

Interviews: included talking to/have e-mail correspondence with experts in building with low-impact/natural materials: prefab straw producer EcoCocon and Halmhus AB as well as the owners/ users of the existing building: Göteborgslokaler AB (the property owner) and the store manager at systembolaget.

Literature studies: was conducted on topics such as straw bale building theory & practice, urban redensification, low-impact materials/research, climate reports and building industry impact.

Site analysis: analyzed prerequisites of the site within the context of the city both historically and physically, influencing the design project.

Building analysis: studied the floor plan of the existing building on the ground floor (Systembolaget) to analyze how the existing premises could be adapted to facilitate the addition.

Case studies: included studies of existing- and planned projects built with straw and bio-based low-impact materials.

Site visit: visited the Swedish prefab straw producer Halmhus AB in Tidaholm to see the production technique as well as the prototype house they're building.

RESEARCH CONCEPTS & APPLICATION

Both research for design and research by design have been conducted, starting off with research for design to generate a basic knowledge base on the main topics before moving into the design phase. The two phases were then carried out in parallel to overlap and inform each other and carry the project forward. This enabled iterations to be done throughout the project and resulted in a circular rather than linear process, building up a solid design proposal embodying the research findings and knowledge generated throughout the thesis project.

Quantitative data

Research on statistics: was conducted to do research on inhabitant growth, Swedish housing market situation and local material availability in Sweden.

Environmental impact assessment/LCA: was conducted to measure the environmental impact of material- and design choices as a guiding tool for design and final assessment.

Daylight analysis: was carried out through daylight simulations to assess the sufficiency of daylight for different design options in the process as well as optimizing the final design.

METHOD DIAGRAM

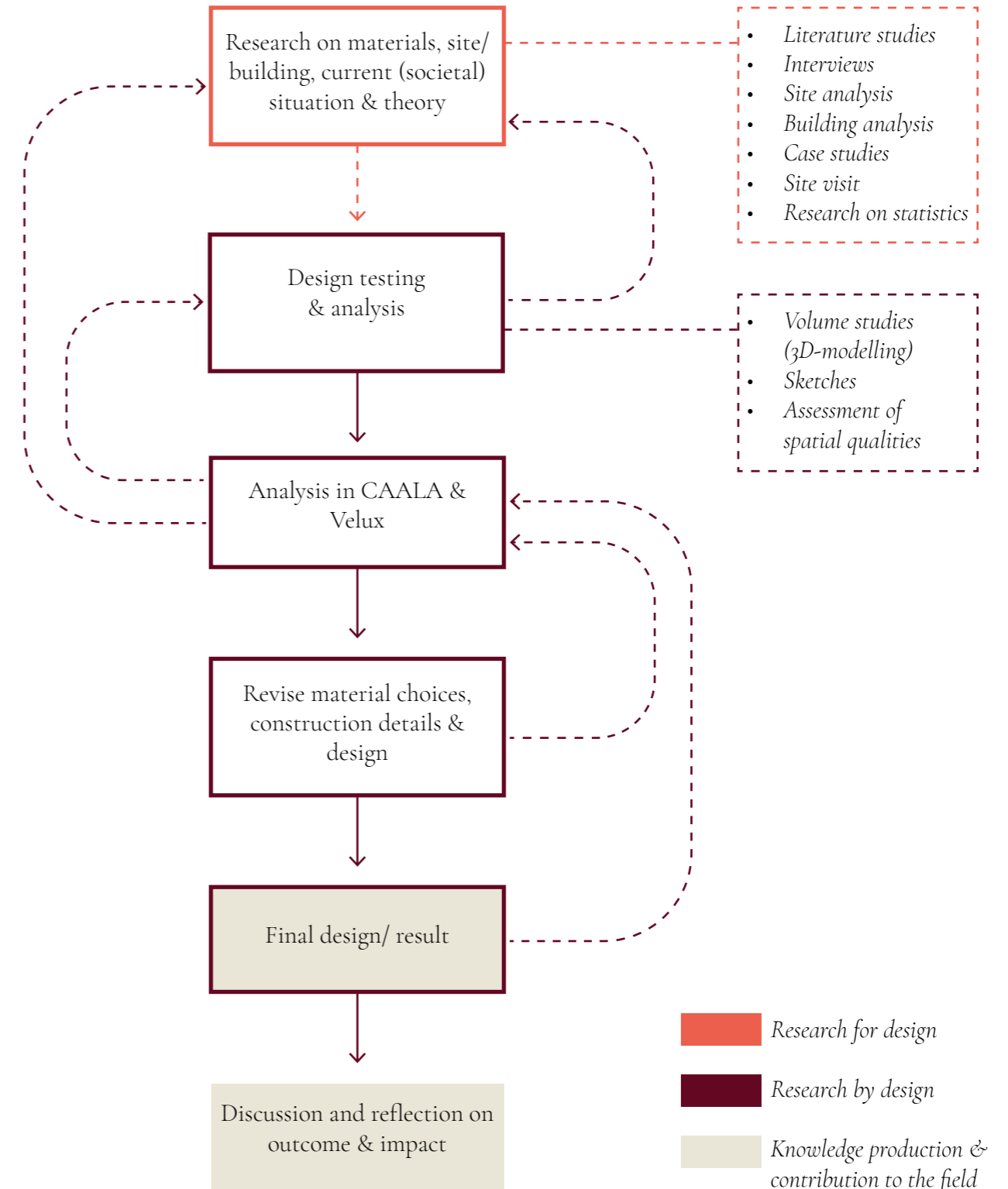

Figure 2: Method diagram

2.

MATERIAL KNOWLEDGE

- Low-impact materials: The importance of material choices
- Theory and preconditions -straw
- The straw module
- Study visit: Swedish prefab straw producer
- Case studies - reference projects

LOW-IMPACT MATERIALS

EMBODIED CARBON - THE IMPORTANCE OF MATERIAL CHOICES

As outlined in the UNEP report “Building Materials and the Climate: Constructing a New Future” it is of highest importance to deselect high-impact materials and shift to low-impact alternatives for new constructions in order to immediately and drastically decrease the emissions from the building industry. Comparing the impact of different material choices is a complex and comprehensive task since it's not only the emissions from the material itself, but also the impact from transportation to the building site. Therefore local availability and choice of transportation is important to consider too. However, to get an indicator of the impact from different materials, carbon dioxide intensity ratio (CDIR) can be measured and compared.

CDIR is the ratio between emissions minus storage (net upstream CO₂ impact) for a material and the material weight. A positive CDIR means a net CO₂ source whereas a negative CDIR means a net CO₂ sink, which is a material containing a greater amount of carbon in its mass than the amount being released in the upstream stages of the life cycle for the material. The potential for “zero impact” in terms of CO₂ contributing to global warming from the buildings useful life may be achieved if the share of carbon from CO₂ stored in the building is greater than- or equal to the total amount of carbon released in the form of CO₂ during the upstream stages of the life cycle for the material. (MacMath & Fisk, 2020)

CDIR: Net CO₂ pollutions (kg) emitted by the production of 1 kg building material

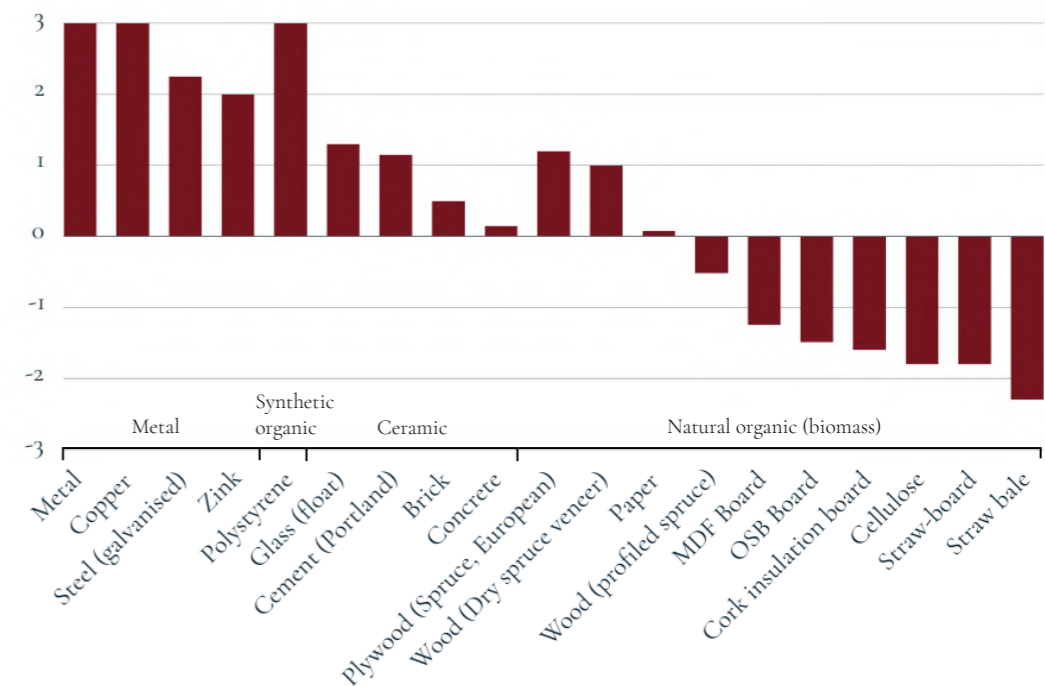

Figure 3: 'Carbon dioxide intensity ratios' data from MacMath, R & Fisk, P (2000) re-visualized by author.

THEORY AND PRECONDITIONS -STRAW

WHAT IS STRAW AND WHAT IS IT USED FOR

Straw is the stalks of cereal grasses/grains such as rye, barley, wheat, oats and buckwheat and the product being left after drying and threshing the grain. Straw from harvested crops is used for maintaining topsoil balance (when it's returned to the soil), animal bedding, cattle forage, heating fuel, ethanol production, building materials, and feedstock for emerging bio-based industries.

BIO-BASED & CRADLE TO CRADLE

Straw is a biogenic and nontoxic material with the ability to absorb large amounts of CO₂ during its growth phase, where between 40-50% of the straw mass is carbon. The procedure of harvesting and baling the straw doesn't involve any chemicals, industrial processes or additions to the straw making it a sustainable alternative to conventional building materials (Magwood, 2016). This also allows for a circular material flow where straw walls can be dismantled if desired and basically put back to the ground where it came from to serve as mulch to the soil, generating new harvests of grains.

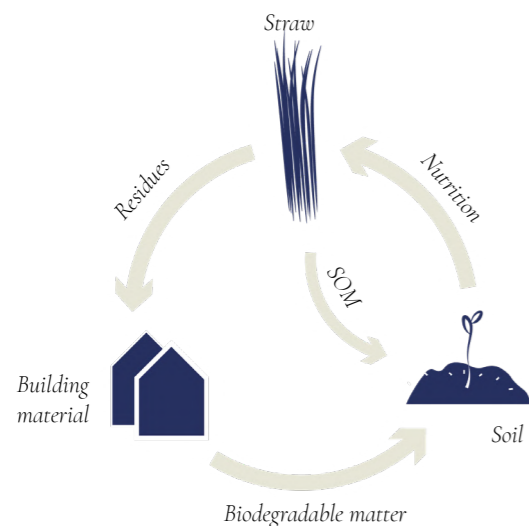

Figure 4: circular flow of resources (straw)

CHEMICALS IN STRAW/ TOXICITY

The relative non-toxicity of the material compared to many conventional construction materials is beneficial for the users of the building as well as the people working in the construction phase. When building with straw the required safety precaution is to wear a face mask to not inhale dust/particles from the straw.

In recent years a connection has been seen between the use of too much fertilizer in modern grain crops and an increased level of nitrates in the straw making it more prone to decomposing if exposed to wet conditions. This applies more to thatch than to walls but could be a potential risk during storage and transportation. Organically grown straw on the other hand doesn't contain chemical residues but is much harder to find an excess of. This straw is less prone to rot and can be beneficial for allergy sufferers but tend to contain a lot of weed which isn't desirable so the choice needs to be carefully considered (Jones, 2015).

Since conventionally grown straw contain some pesticides & fertilizers it could potentially, in the long term, impact the indoor air and health. This would require thorough analyzes and measuring over time and won't be a part of the framework for this thesis.

STRAW FOR THE BUILDING INDUSTRY

As with all changes in balance of material extraction or use, consequences and impact of using straw in a large scale for the construction industry should be critically evaluated and considered. Aspects such as different uses and sustainability goals, with sometimes conflicting interests, is further described in the next paragraph. Since straw has the capacity to store large amounts of CO₂ and is a fast growing resource with an annual surplus there are great benefits of "storing" the carbon in buildings instead of releasing it into the atmosphere immediately again. This is one of many advantages of using straw for buildings, where a healthy indoor climate and reduced energy use are some others.

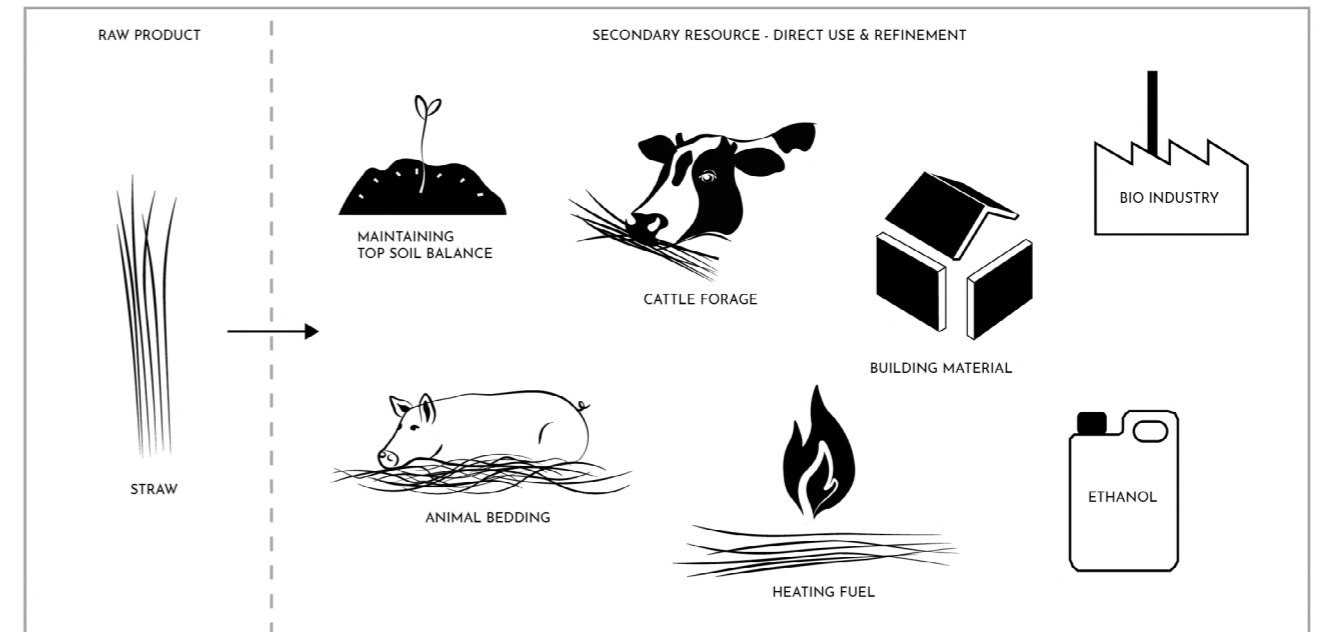

Figure 5: different uses of straw

EU-RESTRICTIONS FOR STRAW EXTRACTION

In EU there are restrictions for how much straw removal that's allowed in the agriculture with the objective of preserving the fertility and health of the soil. This is related to soil organic matter (SOM) which implies decomposed biomass residues. Even though in Europe, cereal straw is an abundant by-product it's important to ensure that a certain percentage of biomass is brought back to the soil to keep these levels stable. The consequences of SOM degradation could be a threat to the food security but also lead to a transfer of carbon sequestered in the soil out to the atmosphere in the form of carbon dioxide which would urge on climate change. There are currently conflicting sustainability goals in Europe between soil incorporation and removing straw for use in the emerging bio-based chemical industry where it has been identified to be the most promising and currently underutilized agricultural feedstock. The main driving force behind the current transition from fossil-based to bio-based feedstock is climate change and the reduction needed of greenhouse gas emissions in the production chain (Björnsson & Prade, 2021).

ACCESS TO LOCAL STRAW IN SWEDEN

In general it's hard to find updated numbers on how much excess straw that's available in Sweden for potential use within the building industry. The general opinion talking to architects with experience in straw building or reading in straw building association discussions is that there's a large excess of straw in Sweden and that it isn't an obstacle in terms of material availability.

The report "Straw as fuel -Part 1: Available resources and harvest times" (Nilsson & Bernesson, 2009) made at SLU (Swedish University of Agricultural Science) shows that the middle- and south regions in Sweden had a surplus of a total of nearly 1 million ton/year. The report was locating where in Sweden there's an surplus of straw and how much, with the purpose of investigating how much straw could be used for bio fuel. The calculation is based on physical availability multiplied with a harvest coefficient taking into consideration practical circumstances such as low levels of soil organic matter and precipitation during the period of harvesting. Then deductions has been made of the usage for cattle forage and animal bedding.

BUILDING WITH STRAW -THREE MAIN METHODS

The original straw-building technique is called Nebraska/load-bearing method which was initiated by settlers in Nebraska, USA, and dates back to the late 1800's when the baling machines were invented. Nebraska technique means that you manually stack straw bales on top of each other, working as load bearing walls that support the roof construction. The technique is straight forward and well suited also for self-builders. Rounded shapes and corners are possible to make and as with all methods it's of highest importance that the construction site is protected from precipitation until the bales are protected and clad, otherwise the straw is ruined. The second technique is the "post and beam construction" or "infill" method where the straw is put into a load-bearing wooden structure and only works insulating. This method requires more material (wood) than the load-bearing method but is beneficial if you're working with big windows or open spans in a room. Another version of the infill construction is the 'lightweight frame' that makes use of the straws structural properties together with (the need for a much thinner dimensioned) wooden frame. (Jones, 2015).

The third method is the more recently developed prefabricated module consisting of a wooden frame/"box" filled with packed straw bales made in advance and assembled quickly on site. There are also examples of hybrid methods where a combination of the load-bearing and infill method have been applied. The choice of method depends on the projects requirements and properties.

PREFABRICATION

There are different levels of prefabrication available today and some of the advantages is that less time is needed at the construction site, making it more efficient and safe since the construction is protected against precipitation as far as possible. Both the load-bearing and infill method to some extent include prefabricated elements where self-builders or contractors produce parts in advance,

often during winter either on site or off site, and build when the weather and climate is the most stable.

THE PREFAB STRAW PANEL

This more industrialized process results in more conventional aesthetics with straight and square panels with sharp corners and not the characteristic curved corners (Jones, 2015). The prefabricated panels can be clad in either lime/clay plaster or with permeable boards such as wood giving it different expressions and protection against local weather conditions. Since this thesis is exploring straw in an urban context and for vertical extension of a building, this method is most suitable and can provide the efficiency and safety needed for this type of urban construction site.

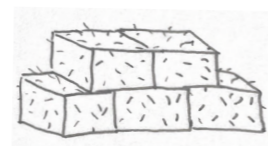

Nebraska style, load-bearing

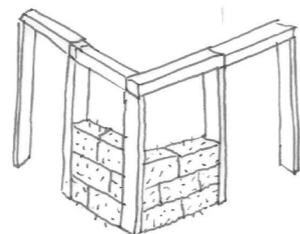

'Post & beam' Infill construction

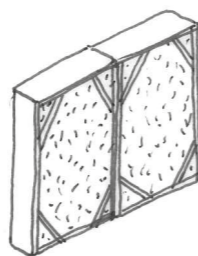

Prefab-panels (straw in timber frames)

THE STRAW MODULE

//TECTONICS & PRINCIPLES OF PREFAB MODULES

THE PREFAB PANEL

The modules/wall elements can vary in size depending on the scale of equipment and facilities of the producer. They can either be built on-site & tipped into place or be prefabricated off-site and built in a production facility, transported on a truck to the construction site and lifted into place with a lifting crane. One of the big advantages with the prefabricated straw panels is the efficiency in the building phase on site and the tidiness on the constructing site making it significantly safer in terms of fire risks with less loose straw laying around.

FABRICATION METHODS

There are a variety of fabrication methods to choose from when producing the panels depending on the desired properties and performance of the wall. The 4 main ones will be described together with some advantages and disadvantages of the technique.

Wet Process: This is the most similar method to site-built straw walls and consists of a coating of clay-/lime plaster on both the interior and exterior side of the wall element.

Advantages:

- Exceptional air tightness and sealing reducing the risk for thermal convection loops.
- Exceptional fire rating & moisture handling.
- Reduces workload on site since the plaster on its own can work as the final finish both interior and exterior.

Disadvantages:

- Resulting in a relatively heavy panel with an average weight of 145-170 kg/ m² depending on the thickness.
- The plaster requires time to cure before being able to move the panel.
- Connecting the joints between the panels requires some additional work on site

(Magwood, 2016)

Dry Process: This method includes no plaster on the panel, instead the straw is encapsulated in an inner and outer layer of a structural sheathing with permeable properties.

Advantages:

- The panel becomes more light weight.
- Requires no curing time and shorter time for assembly.
- Easier to connect the panels.

Disadvantages:

- Sheathing materials and requirements of a thicker frame resulting in potential higher costs.
- Requires an additional rainscreen layer exterior.
- Larger risks of thermal convection loops, reduces thermal performance and issues related to moisture in the wall.

(Magwood, 2016)

Dry Process:

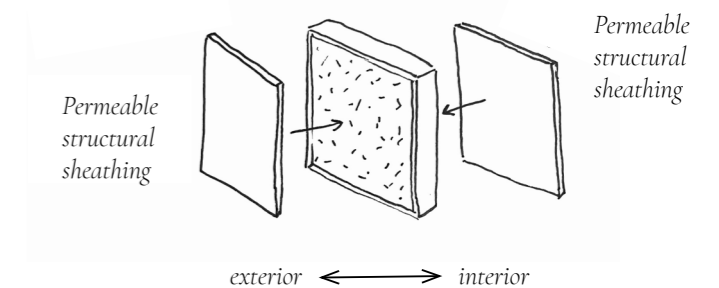

Wet Process:

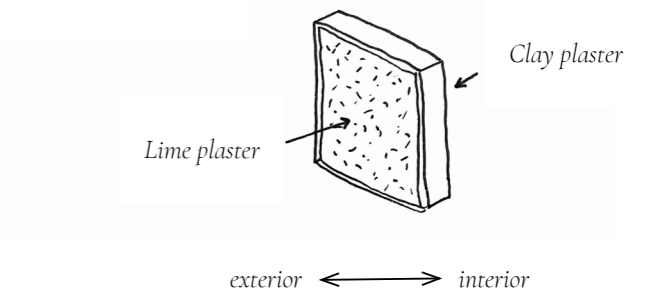

Mixed Process: This method includes both a thinner layer of plaster on the straw and an additional layer of permeable sheathing, bonding with the plaster, on both the interior and exterior side of the wall element.

Advantages:

- Exceptional air tightness and sealing reducing the risk for thermal convection loops.
- Exceptional fire rating & moisture handling.
- Easier to connect the panels.

Disadvantages:

- Resulting in a relatively heavy panel
- The plaster requires time to cure before being able to move the panel.
- The combination of sheathing and plaster materials will increase the costs.
- Requires more labor hours to add both plaster and installing the sheathing.

(Magwood, 2016)

Hybrid Process: This method includes a layer of plaster on both sides, and a layer of permeable sheathing covering the straw and plaster on the exterior side.

Advantages:

- Entails the advantages of a plastered interior wall in terms of the low cost of clay plaster, its good durability and distinct aesthetics.
- Exceptional fire protection.

Disadvantages:

- Entails disadvantages from both the dry- and wet processes.
- The risk of bending increases if the structural properties of the interior and exterior sides differ a lot and will require further analysis.

(Magwood, 2016)

“ The straw wall seems, quite by chance, to solve the dilemma sparked by the oil crisis. What initially began as an ecological experiment, could lead to a new architectural style of “baroque plasticity”. ”

(Deplazes, 2018, p.142)

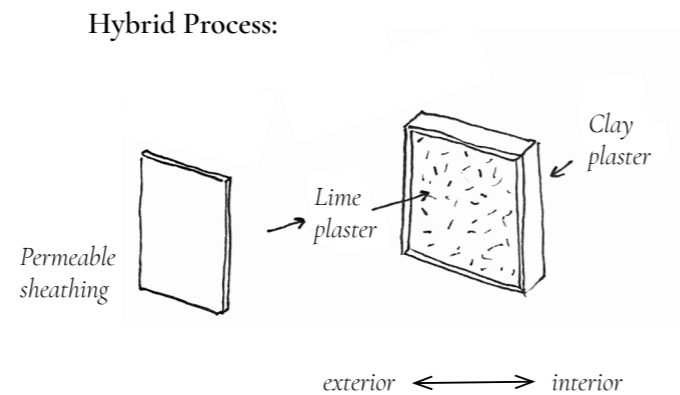
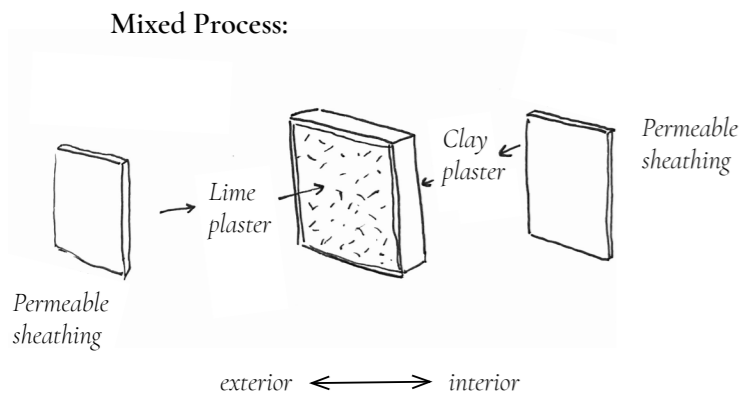

//LARGE SCALE PRODUCTION OF PREFAB STRAW PANELS

SCALABILITY & PROSPECTS

Prefabrication of straw wall panels can include more or less manual work. Smaller producers usually have smaller machines/tools and less means to invest in expensive equipment which results in a higher degree of labor input. The larger producers have more large scale equipment and production facilities giving them preconditions for a more industrial-scale production and efficiency. EcoCocon is one of the most prominent producers operating in Europe. They are currently building a new factory in Slovakia powered mostly by solar energy and with an automated production line as a blueprint for replicating in other countries worldwide. The new factory will have the capacity to produce up to 60.000m² of straw walls annually, which corresponds to approximately 450 new houses of 100 m² each. If the factories and production would become more widespread this would give preconditions for locally sourced and produced straw homes reducing the environmental impact from transportation and also possibly reducing the costs. Putting this in the Swedish context it could be one of several strategies to help supporting the transition to a reduced environmental impact from the building industry.

TECHNICAL SPECIFICATIONS & PANEL COMPOSITIONS

As mentioned there are different ways of composing the panels including different sheathing materials. The original one used for Nebraska style buildings as well as the Swedish prefab panel only consists of straw (+ a wooden frame in the Swedish one), lime plaster and clay plaster, whilst some incorporate wood fiber boards and give the building a wooden facade. Both the wood- and lime plaster facades are viable in terms of weather resistance but requires normal maintenance such as re-painting, strengthening or replacing weather worn parts.

The EcoCocon panels contains 400 mm straw with a density of 115kg/ m³ mounted in a timber frame and covered with 30 mm clay plaster interior & an airtight membrane + 60 mm wood

fiber board exterior. The facade is then clad with a facade diffusion open material and on the interior side the clay plaster is exposed. This gives a wall with a U-value of 0.12 W/(m²k). The complete panel is fire tested and has a fire resistance of 120 min whilst the bare straw panel in frame without any sheathing has a greatly reduced fire resistance.

The Prefab-panel composition:

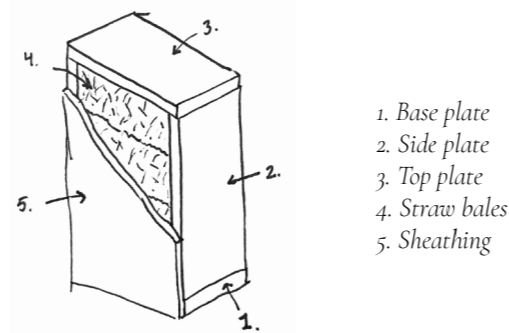

INSTALLATIONS AND FIXINGS IN A STRAW WALL

Installations such as plumbing and electricity in straw walls doesn't differ significantly from conventional buildings. Most common, and recommended, is to primarily install water-carrying pipes in internal, non-straw walls. This is due to the potential risk of water-leakage. However, it's possible to do as long as the pipes are enclosed by a larger insulated plastic pipe. Electrical cables can easily be installed in PVC-free conduits in or on the straw walls. Most common is to surface-mount it on the straw wall and cover it with the interior clay plaster, giving extra fire protection. Wall sockets and switches are mounted a bit further into the straw and fastened in the clay plaster. Internal fittings such as kitchen cupboards/ bookshelves can be attached to walls by using a larger equivalent to plastic rawplugs, but in wood. These are then used as an attachment point to screw the interior into. (Jones, 2015).

The panels from the larger producers comes in standard types and measurements but can be adjusted according to design requirements to a large extent. The maximum number of storeys that can be built with this system is currently set to 6, but depends on the load-bearing capacity of the internal wall structure together with the exterior walls. Pre-assembly of modules are possible making the assembly on site even more efficient. The dimensions for these wall segments are determined by weight/crane lifting capacity, truck trailer length and space required on site and the average construction speed is 120 m² of wall per day with the help of a crane.

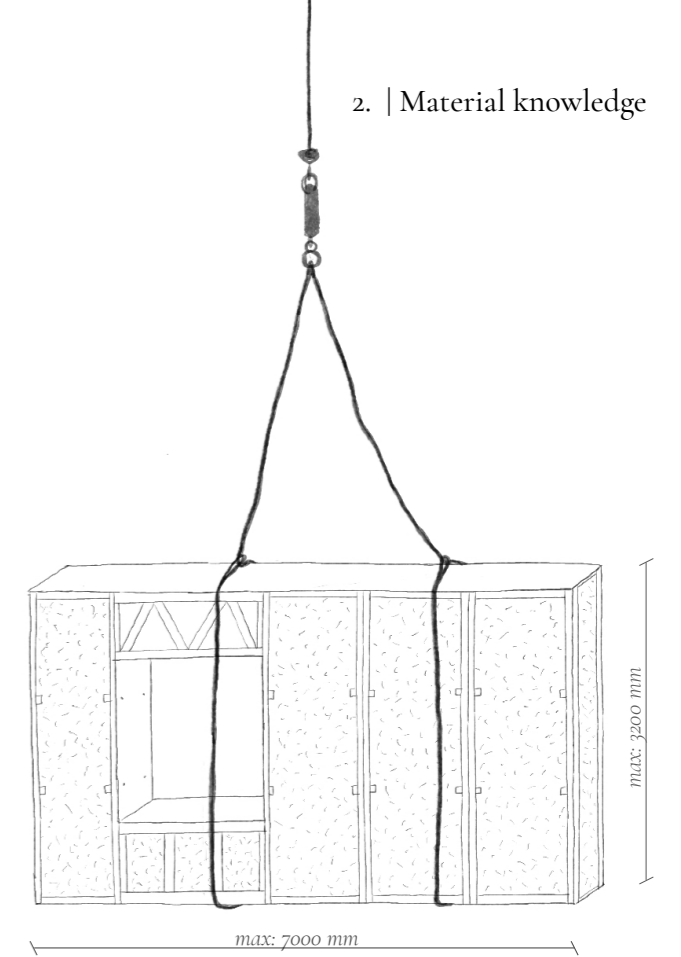
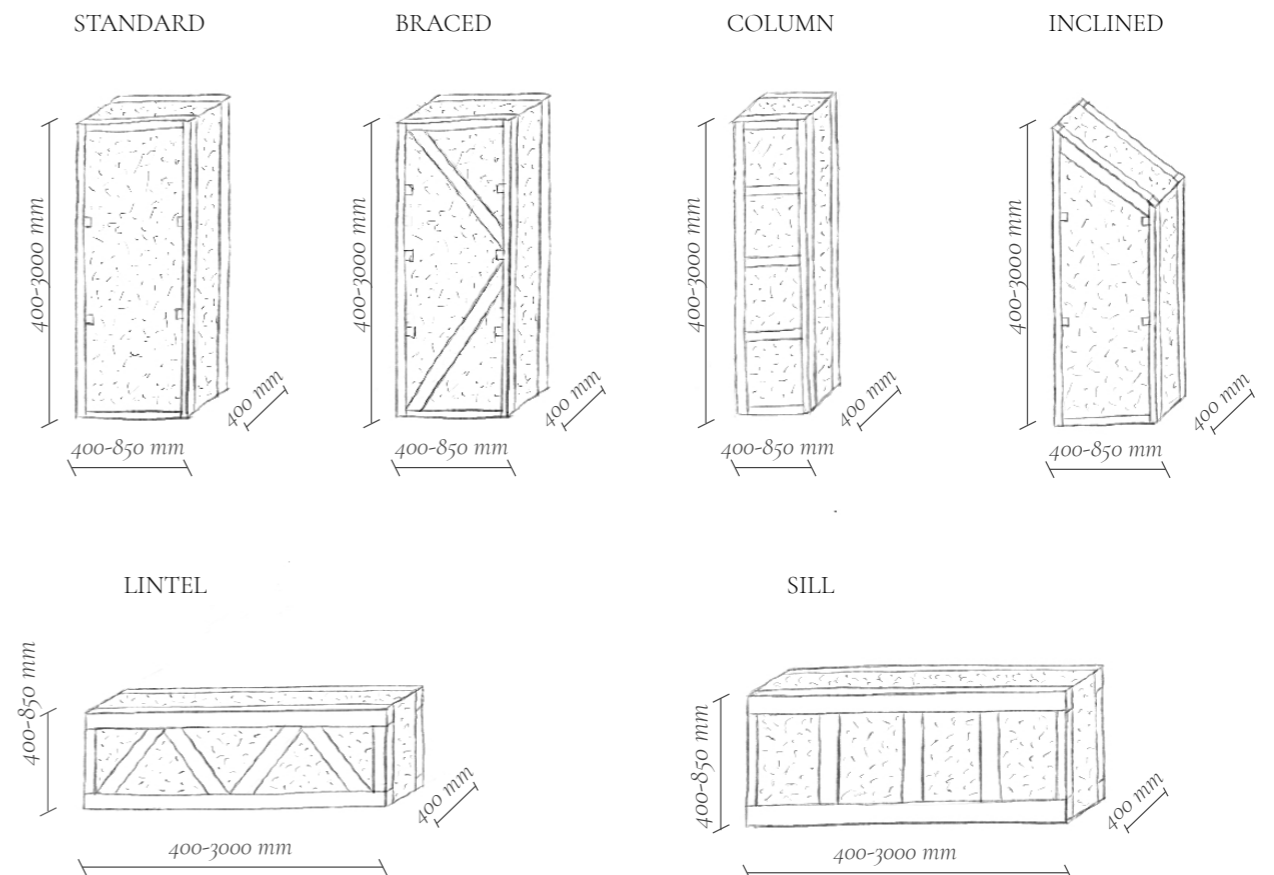

Illustration: Pre-assembled wall element

Measurements for bare panels:



//STUDY VISIT AT A SWEDISH PRODUCER



Image 1. The barn - "factory"
Image 2. Pressed straw bale
Image 3. Section of prefab panels

LOCALLY PRODUCED PREFAB PANELS

In Sweden there is currently one producer of prefabricated straw wall modules, located in Tidaholm about two hours drive northeast from Gothenburg. Early in the process I decided to visit Torsten Lendt, the founder of Halmhus AB with ten years experience in working with natural & ecological building materials and who's an educated straw bale builder since 2017. Together with his wife who's an interior architect, 2 trainees and subcontractors such as carpenters and a constructor he's producing the modules in a barn in Tidaholm and is currently building a prototype house/villa a few minutes away. During our meeting and interview Torsten told me that the straw used is from locally sourced crops in the surrounding fields making the supply chain as short as possible before going into production. The newly harvested straw on the field is controlled in terms of moisture before collecting and baling it on site. The moisture percentage must not be above 18% which would generate a risk for mold or fungi to grow in the wall, around 12-14% is an optimal percentage. In the southern and middle parts of Sweden there is a good supply of residual straw from the agriculture and the best qualitative straw for building with according to Torsten is conventionally grown crops. The ecological straw has a higher amount of hay which isn't desirable in order to ensure a homogeneous structure and quality of the

straw bales. The dimensions of the bales he presses on the field is 360x480x800-850mm compressed to a density of 85-115kg/ m2 wall module. The direction of the straw is important when baling in order to achieve the lowest lambda value. Longitudinal or standing direction in the wall gives a value of 0,046-0,048 whilst if the straw is horizontal from inside to outside the value goes up to 0,06-0,08. When it comes to fire safety and testing of the panels Sweden is lacking behind compared to for example Germany or Lithuania where the large international producer EcoCocon is operating. In Germany corresponding panels with 30mm clay plaster interior and 30 mm lime plaster exterior meets 60-90 minutes of fire resistance whilst EcoCocons panels are tested and approved for 120 minutes with clay plaster on the interior and a 60mm wood fiber board exterior. To test the panels and ensure the fire resistance here in Sweden is a very costly and comprehensive process which would need to be initiated, financed and executed by some higher instance for example the state-owned RICE (The research institute of Sweden). He doesn't see it as profitable enough in Sweden, as for now, to expand the production and invest in a large production facility as long as there's no financial support from the state (like for example in France) and the general interest/ demand for the material increases, but hopefully in the future.



1.



2.



3.

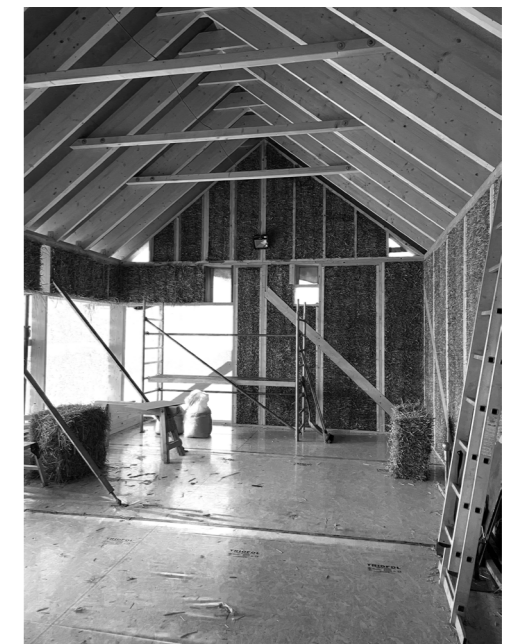

4.

Image 1. Storage of straw bales in the loft
Image 2. Extra densely packed straw (105kg/bale)
Image 3-4. The prototype house in the building phase

CASE STUDY - VERTICAL EXTENSION & URBAN STRAW

Project name: Karper!
Architects: Hé Architectuure
Area: 330 m2
Location: Brussels, Belgium

The project is located in Brussels and focuses on circular economy, co-housing and densification. Through adaptive reuse and additions the former industrial building was transformed into a mixed-use space for townhouse-like residential and co-working spaces on the street level. An infill-method where applied were two added storeys in a wooden frame with straw insulation (loose bales) and brick cladding was built on top of the existing structure. The low-tech approach meant to carefully source materials locally such as straw bales from a nearby farm, and waste soil from building sites in Brussels that became material for the finishing such as clay plaster and rammed earth. Recycling of products and interior was another strategy to prevent extraction of new materials and additional emissions. The project exemplifies a transition from conventional building materials to low-tech and bio-based material with low environmental impact. It simultaneously manifests that these materials and qualities are not solely for rural contexts but also has it's place in the urban setting. Except from the environmental benefits this project shows the inherent qualities and aesthetics of 'back to basic' materials such as straw, wood, rammed earth & clay.

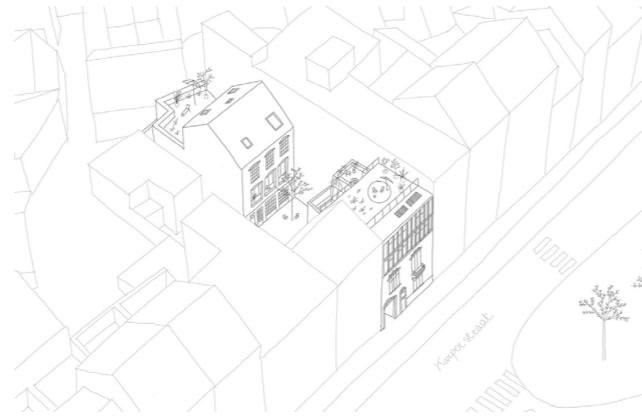

Illustration- Hé Architectuur



Images/illustrations retrieved from Hé Architectuur. Photographer: Van de Velde Tim

CASE STUDY - MULTI-STOREY PREFAB STRAW HOUSING

Project name: LILAC
Architects: Whitedesign
Area: 1500 m2
Location: Leeds, England

The project which was finished in 2013 is located in Bramley- West Leeds, England and consists of a community of 20 households, a community garden and shared facilities. The project comprises a mix of 3-storey multifamily houses with 1-2 bed apartments and some 3-4 bed houses built in prefabricated straw modules from the UK company ModCell developed in collaboration with researchers at University of Bath. The main materials in the buildings are straw, timber and lime render, locally sourced and produced. LILAC stands for Low Impact Living Affordable Community and is a member-led, non-profit cooperative society initiated by a small group of Leeds inhabitants that wanted to change their environmental footprint and live in an alternative, low-impact way. The LILAC development stores about 1080 tonnes of CO₂ and reduces the energy demand by making use of the insulating materials capacity to store solar heat during winter time and reject solar heat during summer in combination with solar thermal energy from PV's for the hot water- and space heating. The community shares facilities and resources such as cars, a workshop/ tools and laundry. Additionally the shared allotments in the garden generates locally produced food to the residents.



Images retrieved from ModCell. Photographer: unknown

3.

DESIGN PROJECT

- Context of the project: Site & Analysis
- Program
- Spatial intervention strategies
- Design principles
- Architectural explorations: process
- Final building design
- Material discussion
- Daylight analysis of the final design
- Environmental impact of the final design

CONTEXT OF THE PROJECT

//SITE & ANALYSIS

LOCATION AND HISTORY OF THE SITE

In the central location of Lorensbergsgatan 3, right behind Avenyn there's currently a 1-storey building owned by the municipal Göteborgslokaler Förvaltnings AB and used by Systembolaget for goods reception and warehouse connected to their store facing Avenyn at Kungsportsavenyn 18. Research on the current and historical detail plans as well as documentation of the property shows that the city plan from 1934 still is the basis for the area and that there was previously a 4-storey building at Lorensbergsgatan 3, built in 1882. The building was used partially as a boarding house (438m²) and five additional apartments of which there was one 1-room apartment, one 3-room apartment and

three 4-room apartments. The building was later mainly evacuated from 1965 until its demolition for unknown reasons in 1974, except from a group of architecture students called "Alternativt samhälle" (translated: "Alternative society") that was renting 3 floors of the premises on Lorensbergsgatan 3 from Systembolaget for 4 months in 1969, before it's demolition, for multi generational gatherings with a anti-commercial agenda, with elements of cultural activities and discussions. This was supported by the city's social administration, showing an interesting history of grass root initiatives and societal engagement. The building was made out of bricks (load bearing walls) and wood (non load bearing



Open source map: Lantmäteriet.se

● Site, Lorensbergsgatan 3

walls + intermediate floors). In the planning matters and detail plans on the property it shows that after the demolition and construction of the current 1-floor building in 1974 there has later been ideas and initiatives to vertically extend the building with 3 additional floors for housing, offices and shops towards Lorensbergsgatan. This was initiated by the property owner at the time, AB Kungsporsavenyn 18, equally parts owned by Göteborgs stads bostads AB and Systembolaget and resulted in a change in the detail plan in 1990.

LATEST DETAIL PLAN FROM 1990 & CURRENT PLANS

The adjustments in the detail plan allows for 4 storeys in total, two more than the original city plan from 1934 allowed. The first floor was proposed for commercial activities, second floor for offices and/

or residential and 3rd-4th floor for residential. The maximum building height was set to +31,9 meters and the maximum total height to +33,0 meters (both from the zero plane). It also regulates that additions needs to be adapted to the adjacent buildings with plastered facade in light colors, tin roof and a mansard roof shape facing the street with a roof angle of 45° for the lower roof pitch and maximum two dormer windows are allowed. The roof surface on top of the 1-storey building are permitted to be covered with a surface that can be grown on. There are currently an investigation going on for changing the detail plan and allow for additional floors to be added on the buildings of Lorensbergsgatan 1-5. The potential permission would then allow for 2 additional floors on Lorensbergsgatan 1 and 5 and a total height of 5 floors on Lorensbergsgatan 3.



LOCAL SERVICES & CLIMATE DATA

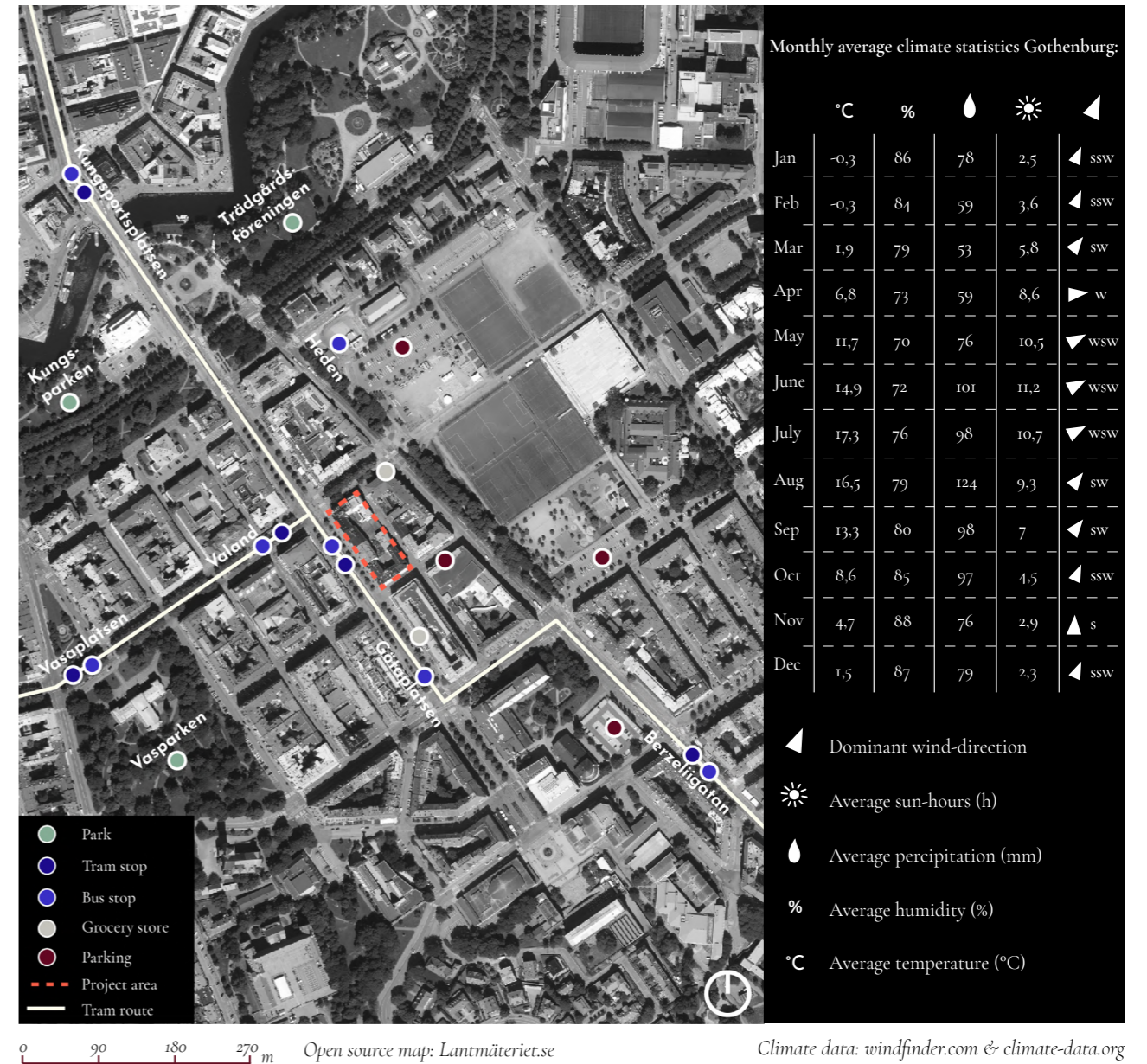

CULTURAL ENVIRONMENTAL VALUES

The building on Lorensbergsgatan 3 is not covered by Göteborgs bevarandeprogram (translated: Historic environment program) and considered particularly valuable but is part of the story of the later, modern, development of the area. The Character and cultural environmental values of the street Lorensbergsgatan and its surroundings is described and analyzed in the report 'Kulturmiljöutredning Kvarteren omkring Lorensbergsgatan' (translated: Cultural environment investigation The neighborhoods around Lorensbergsgatan) made by Fredrik Badh at Göteborgs Stadsmuseum in 2022. The report was initiated and executed in parallel with an investigation for a new detail plan for the area facilitating housing etc. It describes how ideals of the 'stone city' such as an increased protection towards fire as well as improved light- and air conditions was achieved through regulating the build environment. These ideals was applied when the city center expanded according to the 1866 city plan and the districts Vasastan and Lorensberg was built, with main flows directed to Kungsporsavenyn and Vasagatan. The narrowest streets was the 12m wide backstreets Lorensbergsgatan, Teatergatan and Bellmansgatan which functioned as supply streets, subordinated to the main streets in terms of building heights, exclusiveness and facade detailing. Parts of the late 19th-century buildings in the area came to be demolished or modernized during the 20th-century giving the area a today mixed character, but Lorensbergsgatan has to a large extent kept its character of a backstreet with clearly lower building heights. The distinction between the main streets and the backstreets reflects both a social differentiation as well as pure logistic aspects and the silhouettes of Lorensbergsgatan is characterized by accentuated, higher corner buildings with chamfered corners, meeting the more prominent surrounding main streets Vasagatan and Kristinelundsgatan. During the 1960's-80s several individual houses from the 19th-century was demolished on Lorensbergsgatan in the quarter 53 Örup and the 'stone city' quarter

structure with open inner courtyards and readable facade divisions that broke up the scale was removed, not just here but throughout the city, and replaced with bigger complexes of deeper building. The new buildings on Lorensbergsgatan related to the older structures in terms of a lower building height and facade divisions but the expression was modernistic or postmodernistic, moving away from the previous artisanal construction and reflecting the large-scale industrial building seen at the time. New features in the cityscape was plinths in concrete, plastered facades in simple geometrical patterns/decorations, glass concrete, french balconies and bay windows. During the 21st century the ideals has rather been to densify and create scale-wise uniform blocks also on the more narrower streets, focusing less on the functionalistic ideals of light and airy quarters. The Building on Lorensbergsgatan 3 from 1974 that replaced the former 4-storey building from 1882 has more or less been kept unchanged except from a door that replaced a former window. This is an example of when the new building built away the former quarter structure and covered the courtyard since it's now attached to the building on Kungsporsavenyn 18. The buildings conformation also clearly reflects its purpose as a supporting function and warehouse.

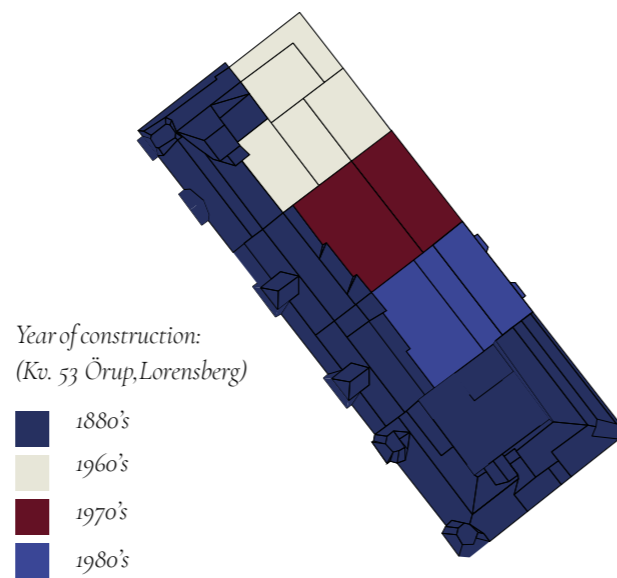

Photographs from 1974 of the previous buildings on Lorensbergsgatan 1-7.
Photos: Göteborgs stadsmuseums open archive.



Photographs from 2024 of the current building on Lorensbergsgatan 1-7 (Authors).

The change over a 50-year period

SITEPLAN & CURRENT PRECONDITIONS

The longitudinal side of the block is positioned predominantly in an ENE respectively WSW direction. The total area of the roof which will be partially built on is 554m² and the distance to the building on the opposite street of Lorensbergsgatan is 12 meters.

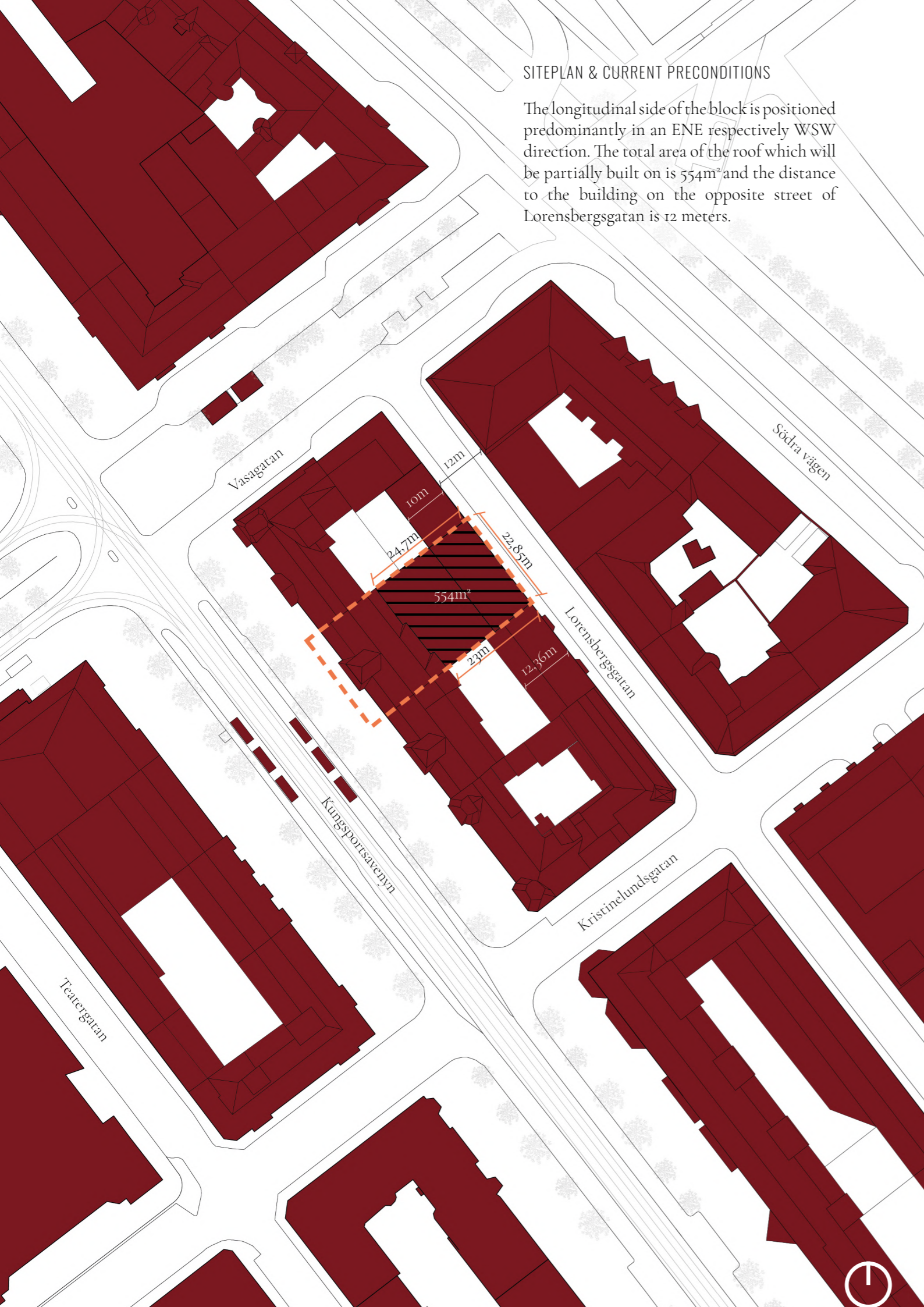

CURRENT USE & PRECONDITIONS

The total area of the infill plot (the existing roof of the 1-storey building) is approximately 549 m². The distance to the opposite building within Örup 53:3 on Kungsporsavenyn 18 should minimum be 8m in terms of fire safety regulations and daylight conditions must also be considered and further analyzed. Initial analyzes gives a buildable area of approximately 280 m² on Lorensbergsgatan.3 between the two adjacent buildings. When a new volume is added on the site an inner yard is created

in the void between the two houses on the first floor level which can advantageously be used as a secluded green common outdoor space/ courtyard for the residents. Lorensbergsgatan is calmer than Avenyn with only a few restaurants, one small hotel, some offices, housing and a grocery store. Car traffic is prohibited on the street between 23-05 all days except for goods delivery vehicles. Systembolaget receives deliveries 4 days a week, which takes place indoors in their loading dock.

Elevation Lorensbergsgatan no.7-1
Scale 1:500

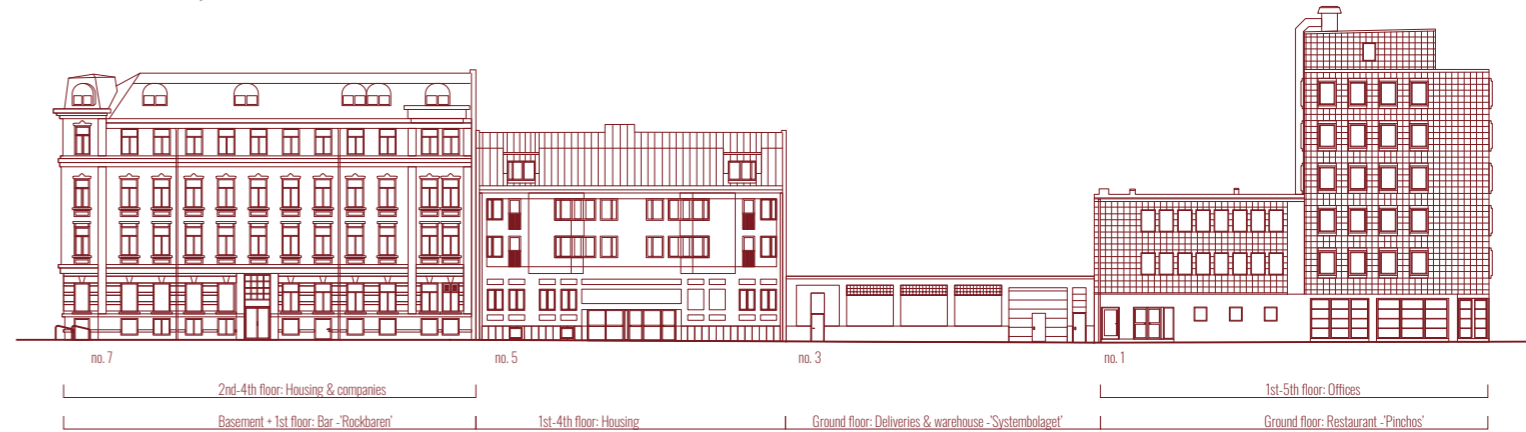

Elevation Lorensbergsgatan no.2-8
Scale 1:500



//SITE & ANALYSIS -SOLAR STUDY

VERNAL EQUINOX
20th March 2024

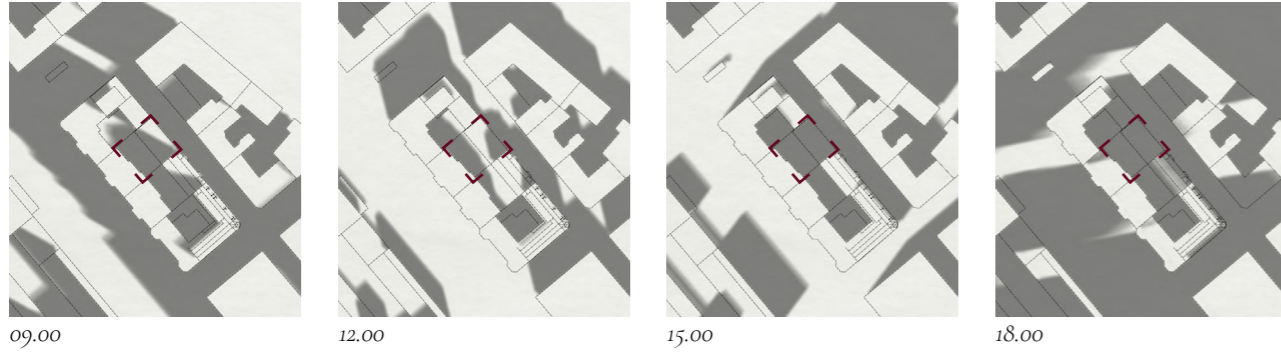

SUMMER SOLSTICE
20th June 2024

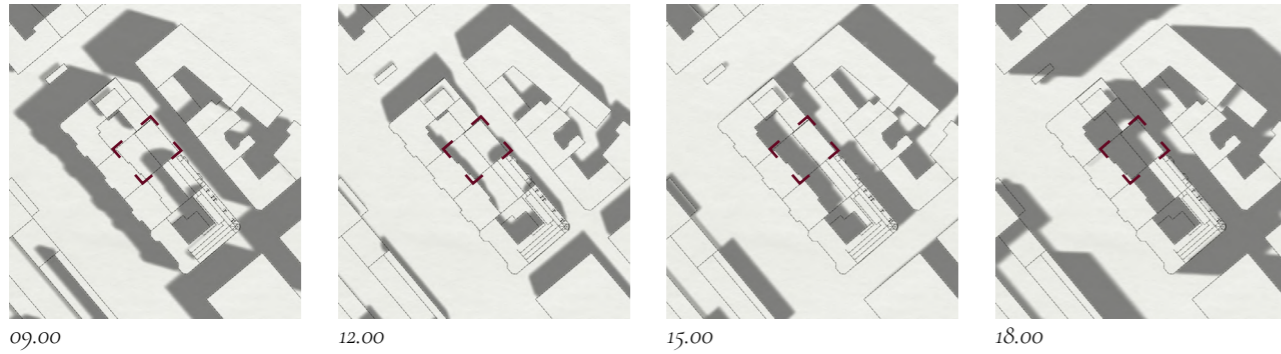

AUTUMNAL EQUINOX
22nd September 2024

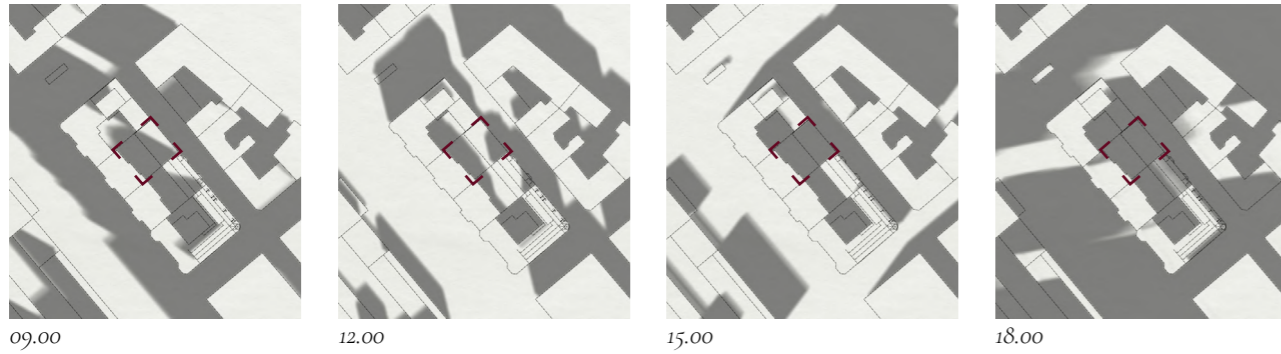

WINTER SOLSTICE
21st December 2024

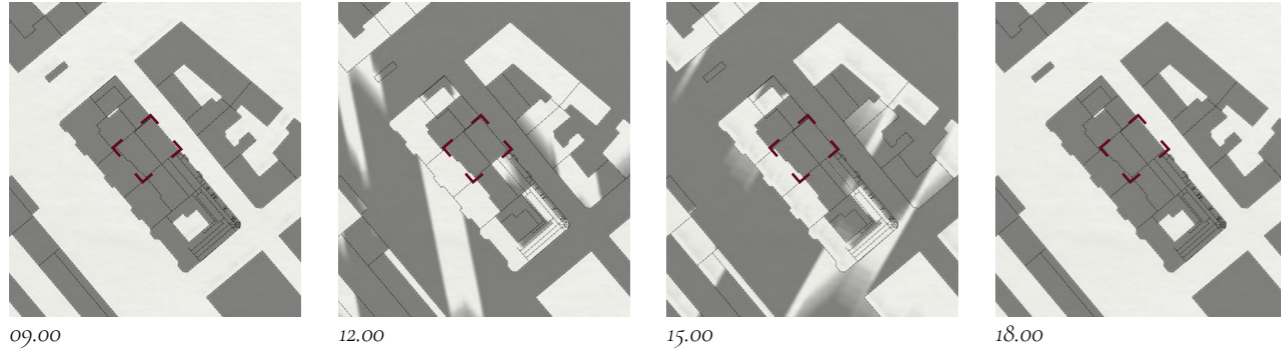

//PHOTOS OF DETAILS ON SITE



Entrance garbage room

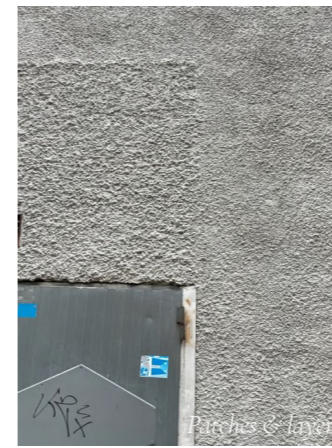

Patches & layers



Facade - materiality & textures



Facade - openings



Meeting with adjacent building

Author's photographs, 2023

PROGRAM

The program consists of housing with an emphasis on smaller apartments (mainly 1-rooms) targeting a younger user group, along with a few 2- and 3-room apartments to facilitate a mix of users. Interior apartment dividing walls are placed according to a rational grid creating 'modules' of repetitive sizes on each floor. Some of these could be removed to create larger apartments but in order to generate more apartments rather than larger apartments this grid was followed, except for on the 4th floor where the apartments has individual terraces and the floor plan layout differs a bit.

Special preconditions given by the specific site is that there's not an ordinary ground floor available since this is the premises used by systembolaget. This results in a less conventional solution where entrance with stairs/elevator and postboxes as well as a technical room and garbage room is located on the ground floor, whilst the bicycle- storage and pool, a shared laundry, a shared workshop/"tool-pool" and the common courtyard is located on the first floor and the storages are located on the roof together with the common roof terrace.

Several floor plan layouts, typologies and circulation options were tested and evaluated during this process and the final design comprises an exterior entrance balcony, giving the benefits of reduced dark interior corridors as well as 2-way daylight and outlooks in all the apartments as well as the circulation area. The balcony also functions as a semi-private outdoor space for every apartment where neighbors meet and can overlook the courtyard facing southwest.

PROGRAM AREAS:

Number of apartments: 14
 Number of 1-room apartments: 10
 Number of 2-room apartments: 1
 Number of 3-room apartments: 3
 Total BOA (apartment area): 594,1 m²

Shared facilities includes: laundry, bike- storage/ pool, workshop/"tool-pool"
 Total area shared facilities: 57,8 m²

Total area entrance balconies: 111,8 m²

Total area shared roof terrace (walkable) : 150 m²

Total area individual terraces: 41 m²

Total area storages: 51,6 m²

Total BTA (gross area): 1011 m²

BTA 1st floor: 237 m²

BTA 2nd floor: 246 m²

BTA 3rd floor: 246 m²

BTA 4th floor: 202 m²

Bta 5th floor/roof: 80 m²

Total BYA (building area): 0 m² (since the building stand on top of the existing building/ roof and occupies no new ground)

SPATIAL INTERVENTION STRATEGIES

//DIAGRAMS

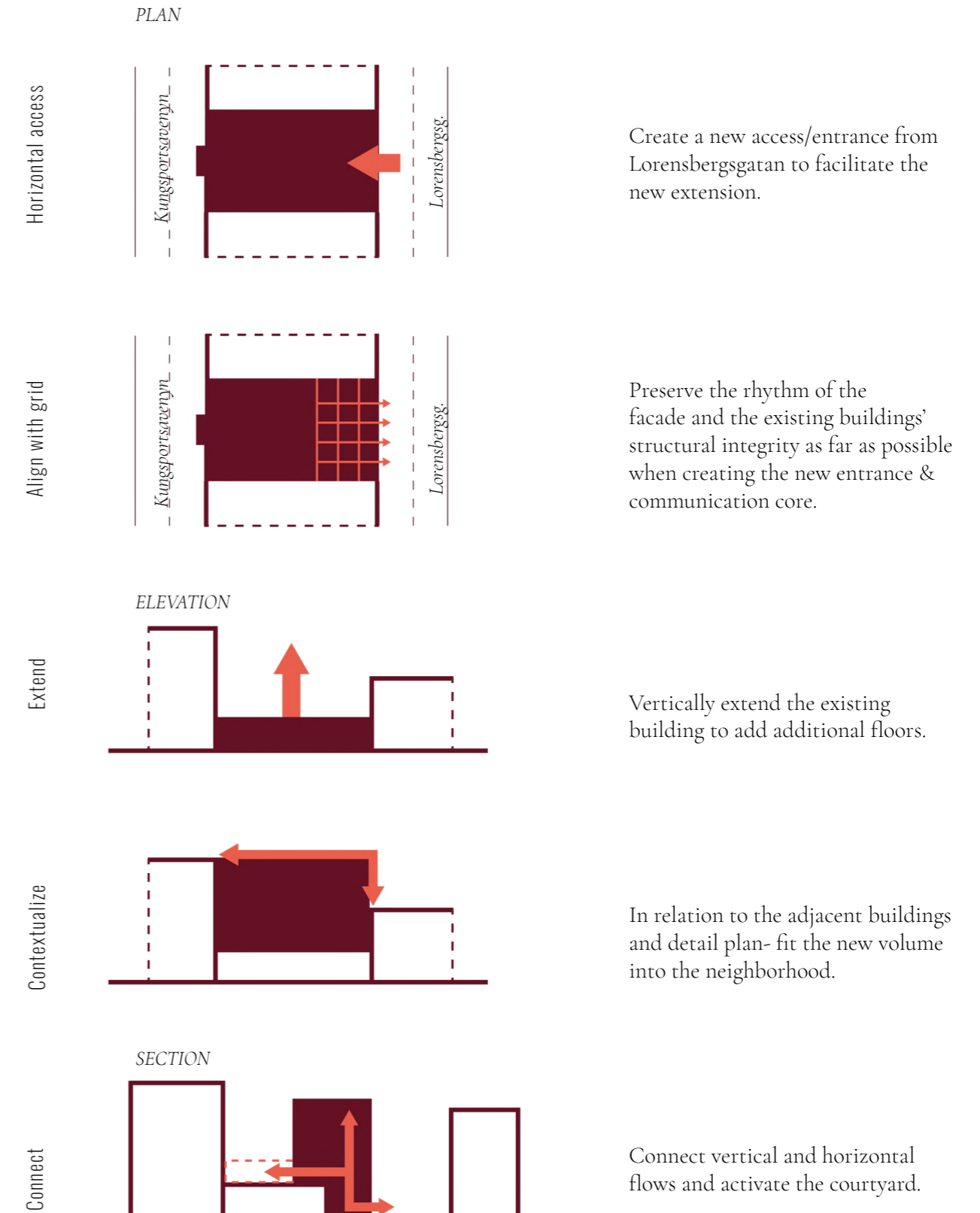

DESIGN PRINCIPLES

//DIAGRAMS

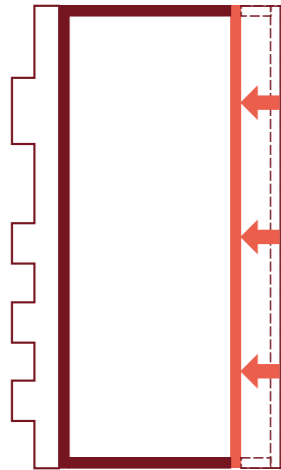

1. Push back: the facade on the 4th floor is pushed back, aligning with the stairwell in order to lower the perceived height of the building and generate private outdoor spaces to the apartments.

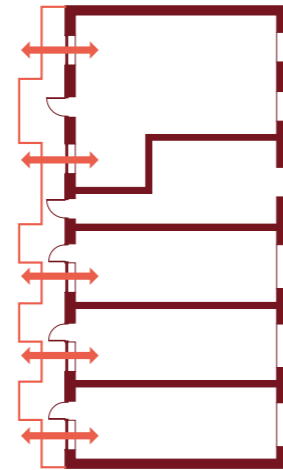

2. Align: The windows and the shape of the entrance balcony are carefully shaped and placed in order to maximize daylight in the apartments and to have an balcony directly outside the entrance door.

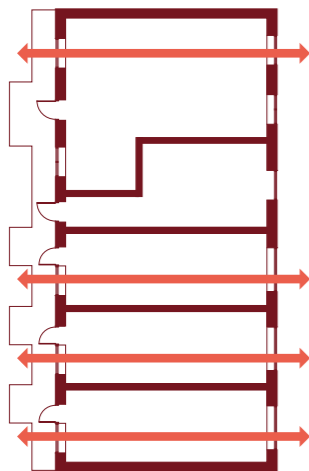

3. Pervading apartments: By moving the internal corridors/circulation to the exterior entrance balcony all apartments receives 2-way daylight and outlooks from the apartments.

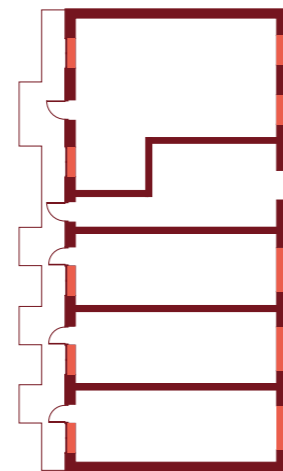

4. 2-in-1: By actively working with the design of the window sills in terms of height/placements and making use of the wall depth, the 40cm deep window sills works as niches to sit in.

ARCHITECTURAL EXPLORATIONS

//THE PROCESS

ENTRANCE SITUATION

The warehouse building on site consists of a concrete structure with load bearing exterior walls and pillars/ beams to support the open floor plan. The interior floor level height is 1,2 meters above the exterior street level high towards Lorensbergsgatan which requires an intervention of lowering a part of the slab that will become the new entrance hall for the housing. This creates a generous entrance hall with a ceiling height of ≈5m and the strategy is to follow the grid of the existing structure and facade when placing the entrance in the building. In order to minimize the reduction of usable space and floor area in the premises of the warehouse the entrance is located next to the goods delivery. The tests below (A & B) show two alternative layouts for the entrance, stairs and elevator. In this early stage garbage room and technical room was not added yet, but came to be located in connection to the entrance in the final design.

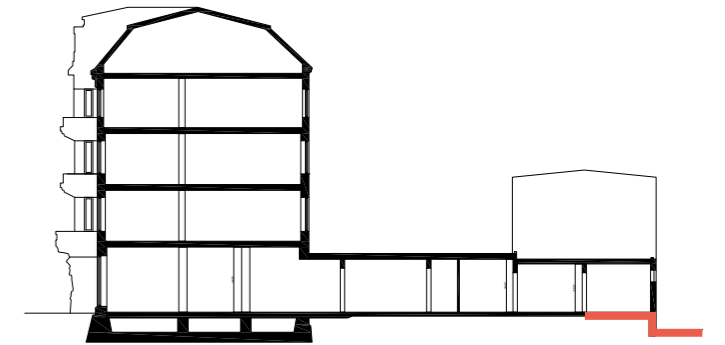

Section A-A showing height difference (in orange)

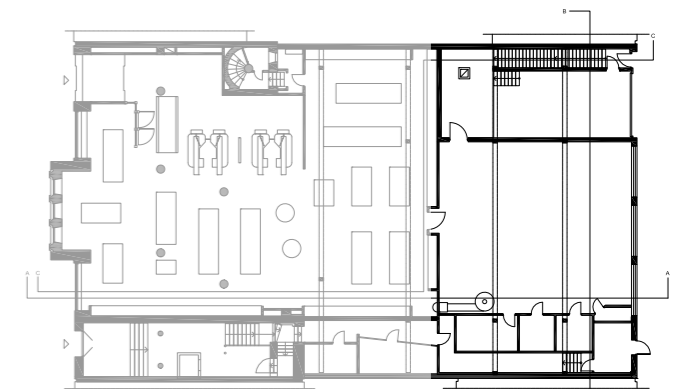

Current ground floor plan of Systembolagets store (left) and warehouse (right)

TESTING OF ENTRANCES

Entrance/communication

Alternative A)

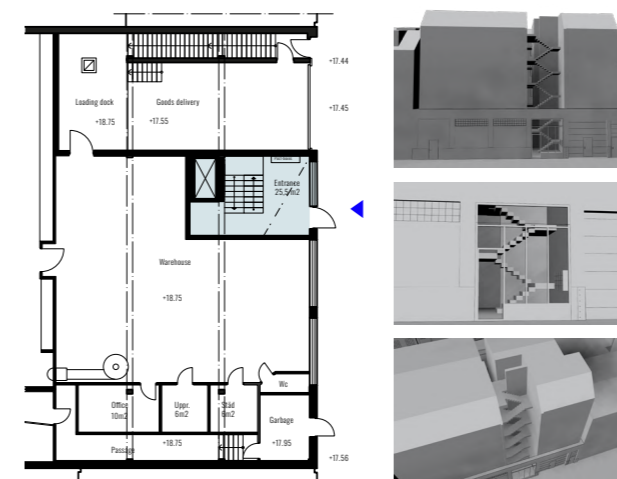

Alternative B)

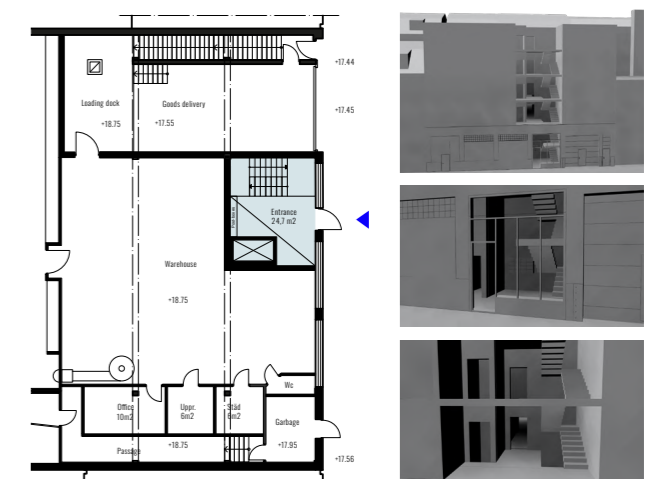

APARTMENT TYPOLOGIES, CIRCULATION & SIZES

With a point of departure in the mapping of apartment typologies, target groups and different concepts of housing, various design solutions and site specific tests were carried out. The different alternatives went through iterations, daylight analysis and an initial GWP- (Global Warming Potential)/energy analysis to evaluate the options which led to the decision for the volumetric concept and floorplan layout. The design option tested out was:

- **#1:** Autonomous 1-storey apartments with entrance balcony (Reducing dark interior corridors, maximizing rentable space and offering balconies & 2 way daylight/outlooks to every apartment)
- **#1.5:** Autonomous 1-storey & duplex apartments with entrance balcony (Same as above but also some apartments with double ceiling height resulting in fewer apartments/rentable space).
- **#2:** A mix of autonomous duplex + 1-storey apartments including 4 student apartments (Large apartments suitable for families but problems with daylight, some dark interior corridors and difficult floor plans to solve in a good way, private roof terraces for apartments on the top floor)
- **#3:** A mix of autonomous duplex apartments with an extra entrance, 1-storey apartments & student rooms with shared facilities (Focus on sharing economy and economic resilience, generous double height space in duplex apartments resulting in less rentable space)

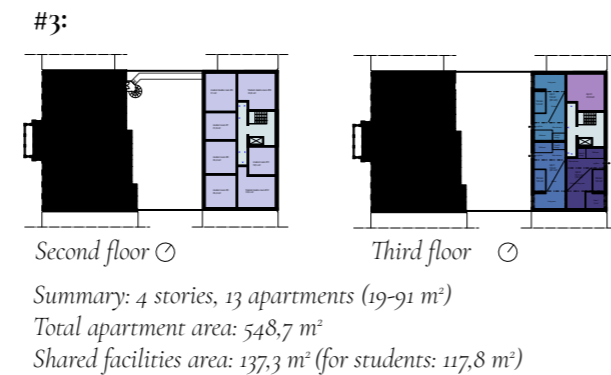
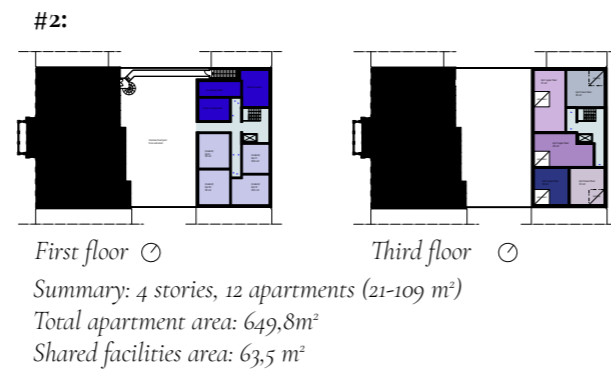
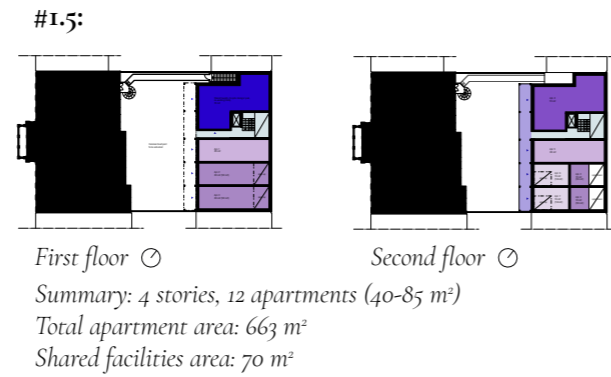
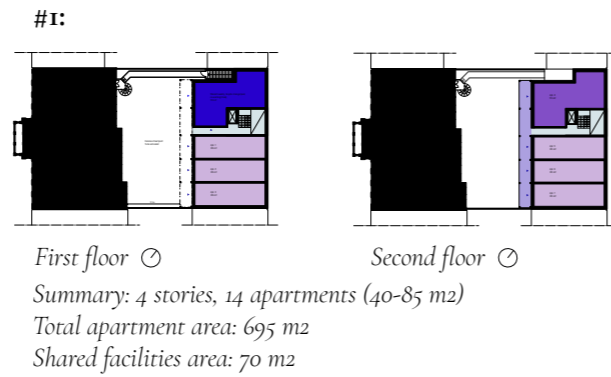

VOLUMETRIC STUDIES IN 3D

When modeling the options I've worked with two scenarios. The first one is showing the current state of adjacent building heights, and the second is showing the suggested new building heights with two storeys added on each of the two buildings. This development is currently requested from the building owners and under processing and is therefore a likely scenario to relate to in the future.

SELECTION

Alternative #1 with its rational and flexible structure, maximized rentable space, two way outlooks & daylight with possibility for cross ventilation as well as good preconditions for developing additional qualities were chosen as the option to continue with and develop further in the design process.

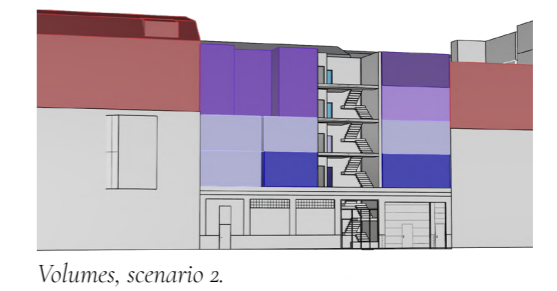
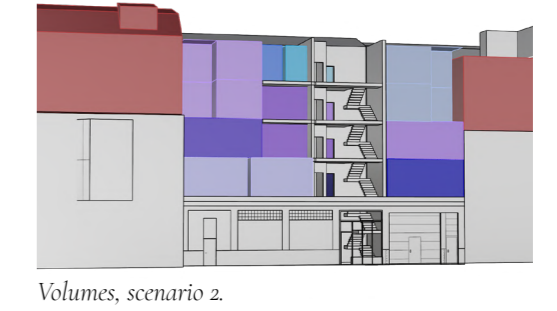
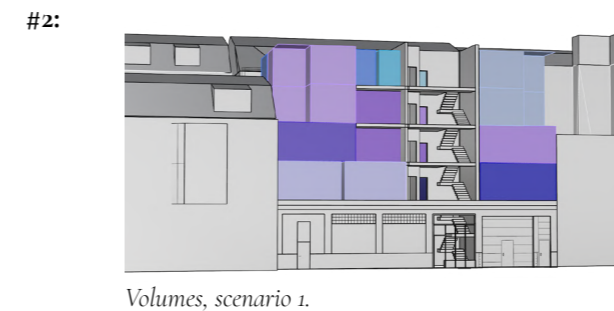
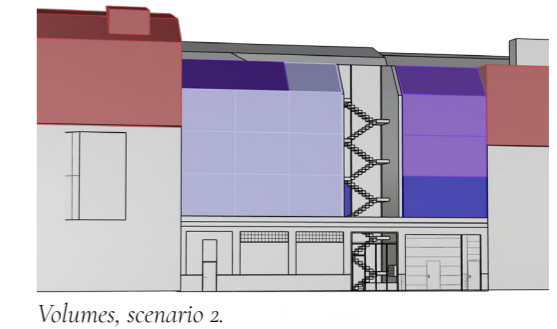
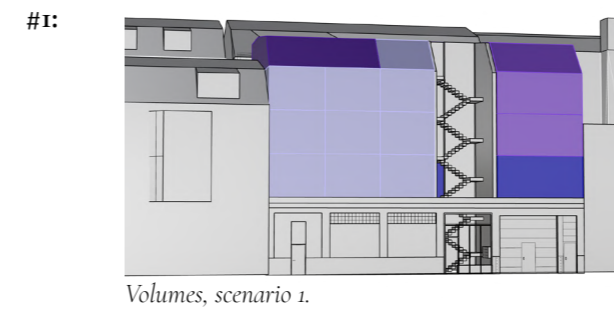

FINAL BUILDING DESIGN



Exterior perspective (street)

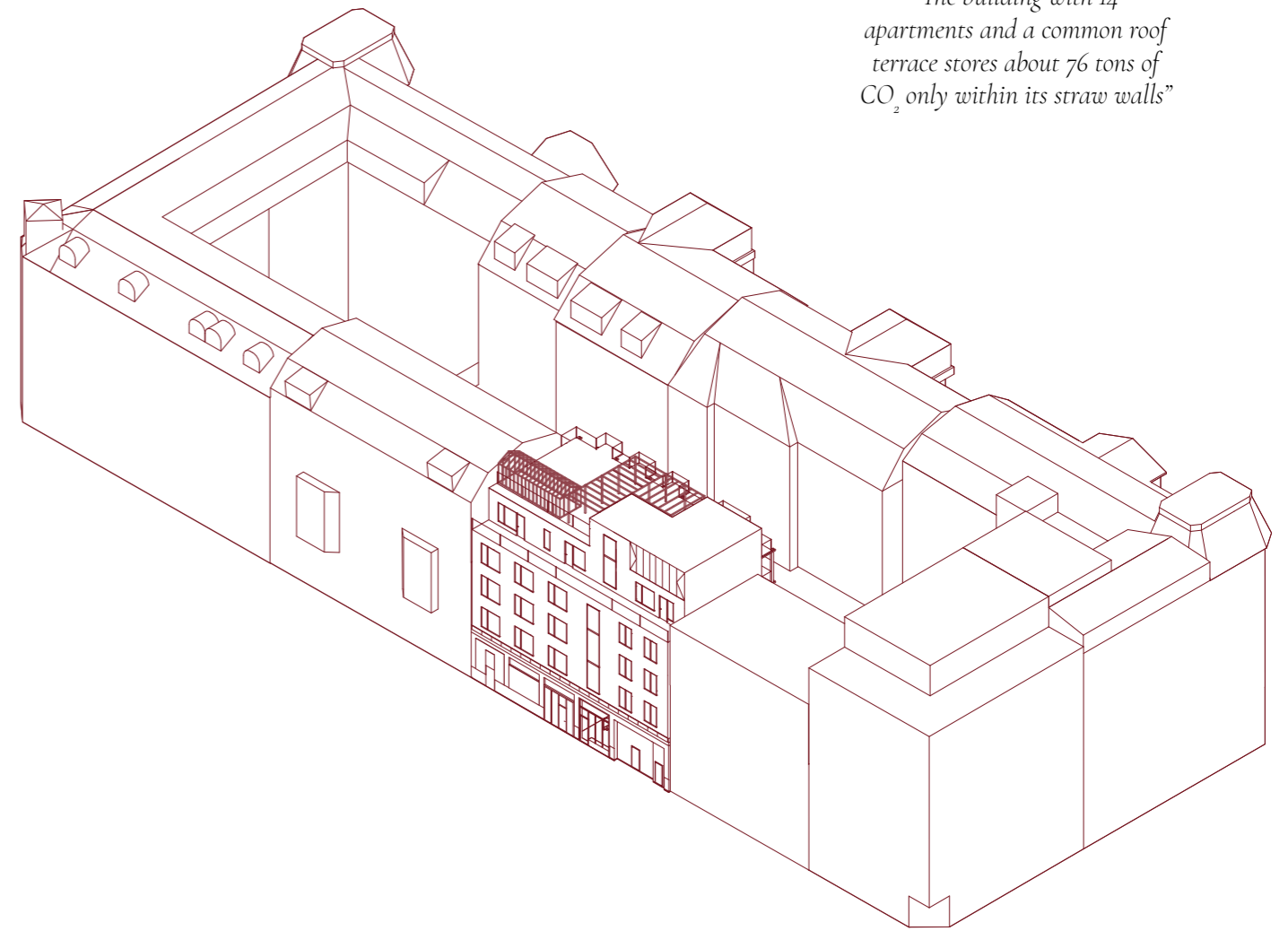

“The building with 14 apartments and a common roof terrace stores about 76 tons of CO₂ only within its straw walls”

Axonometry from Northeast -The building in its context

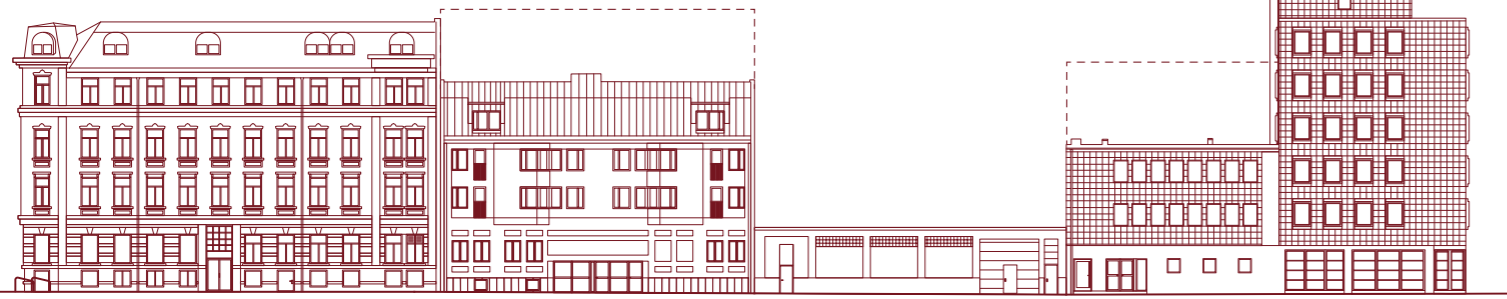

Before: Elevation Lorensbergsgatan (street) 1:500



Elevation (street) 1:200



After: Elevation Lorensbergsgatan (street) 1:500

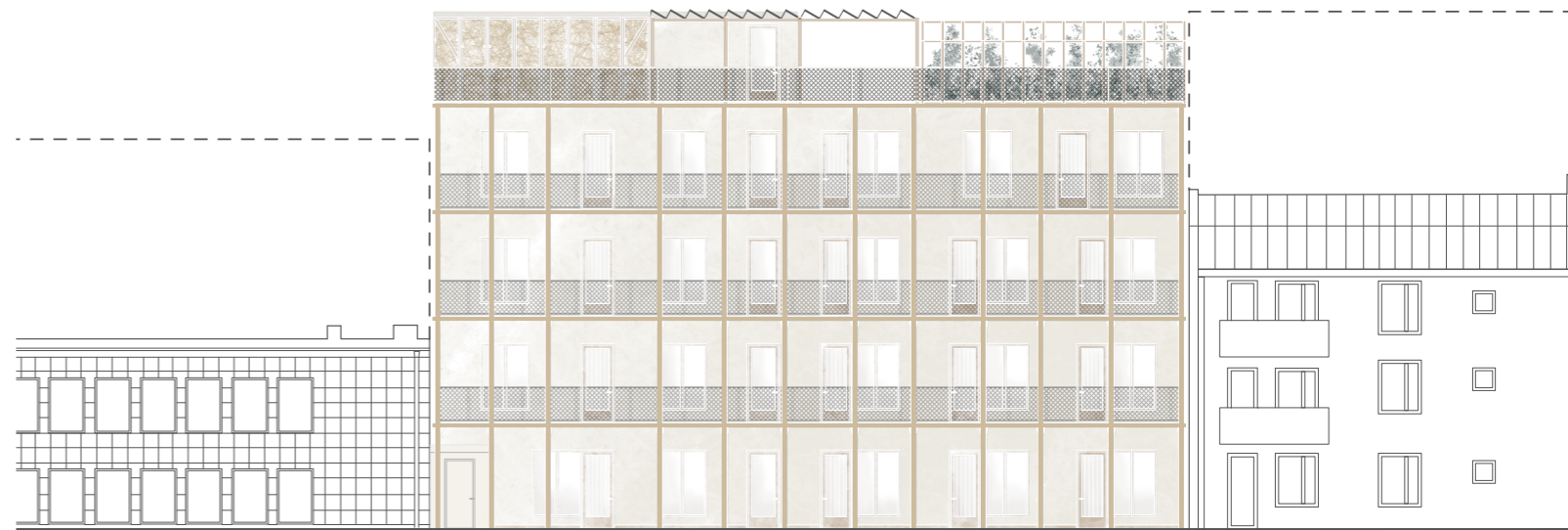

Elevation (courtyard) 1:200

warehouse

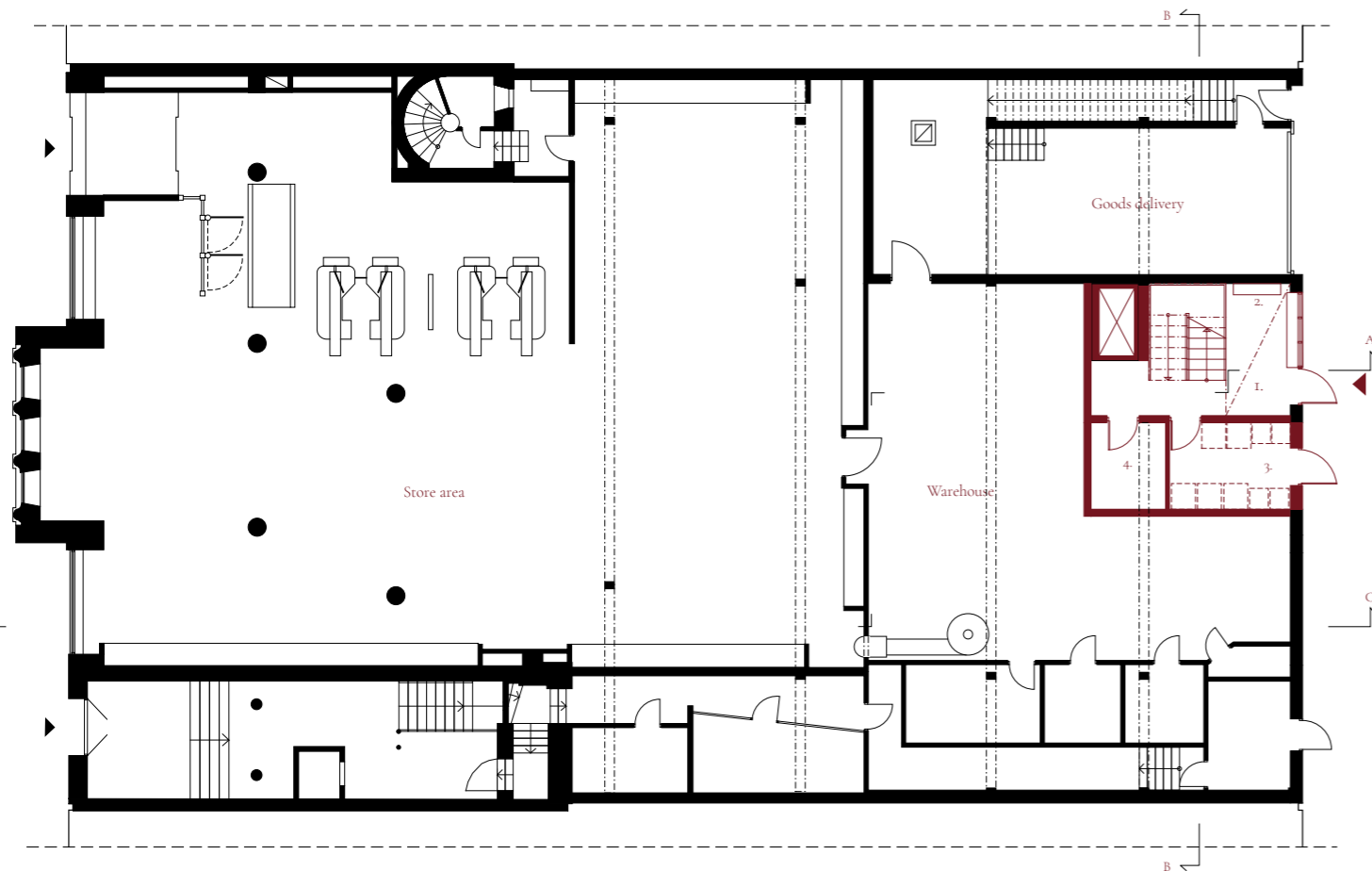

0 1 5 m
Ground Floor 1:200

Existing
New

1. Entrance hall
2. Postboxes
3. Garbage room
4. Technical room

A transformation of a part of the current warehouse into an entrance was necessary for the residents to reach the apartments. Postboxes, garbage room, stairs and elevator as well as technical room is located on the ground floor.

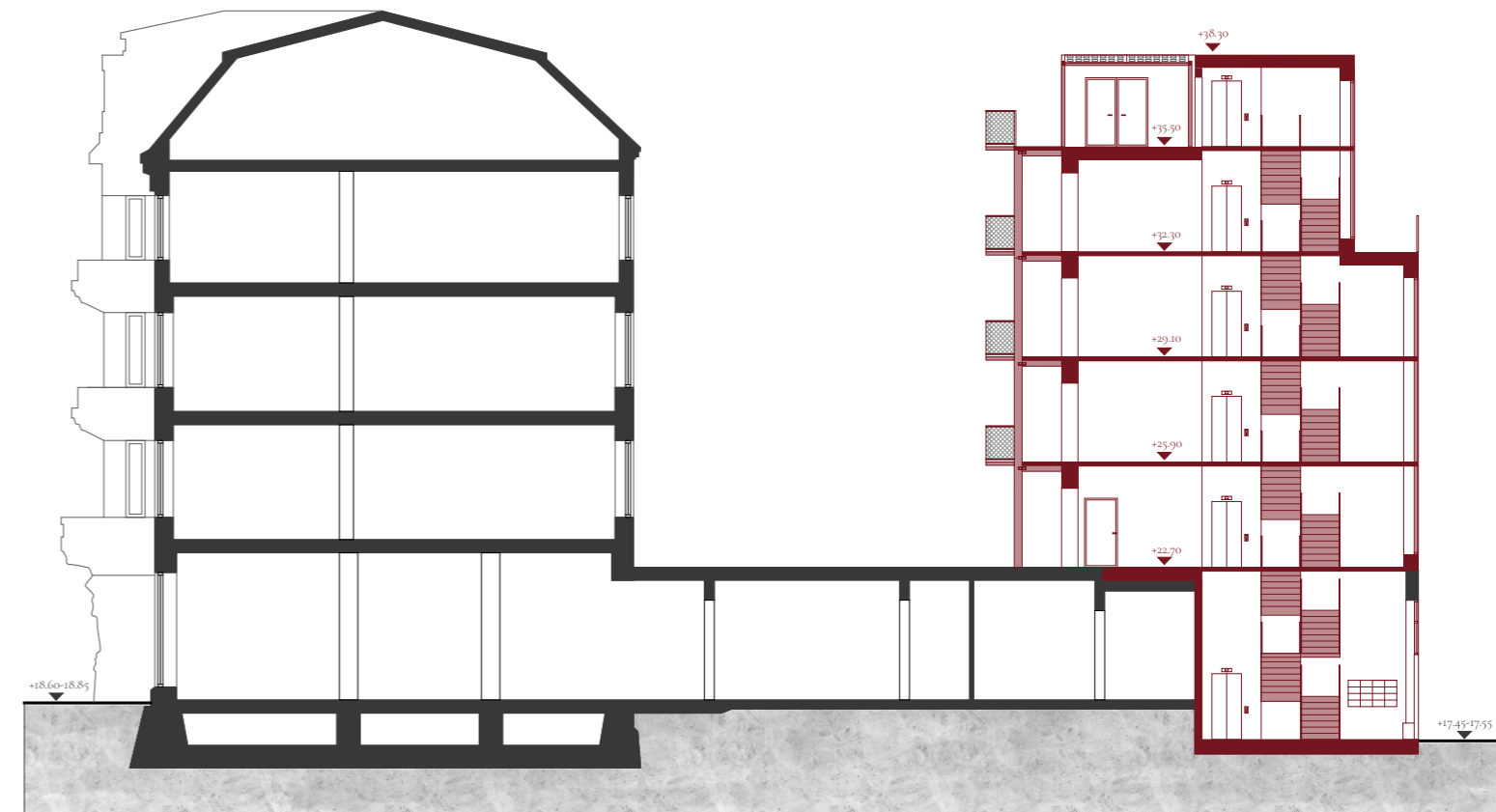

0 1 5 m
Section A-A 1:200

Existing
New

The apartments are reached by an exterior timber structure, the entrance balcony, facing south-west and the common courtyard.

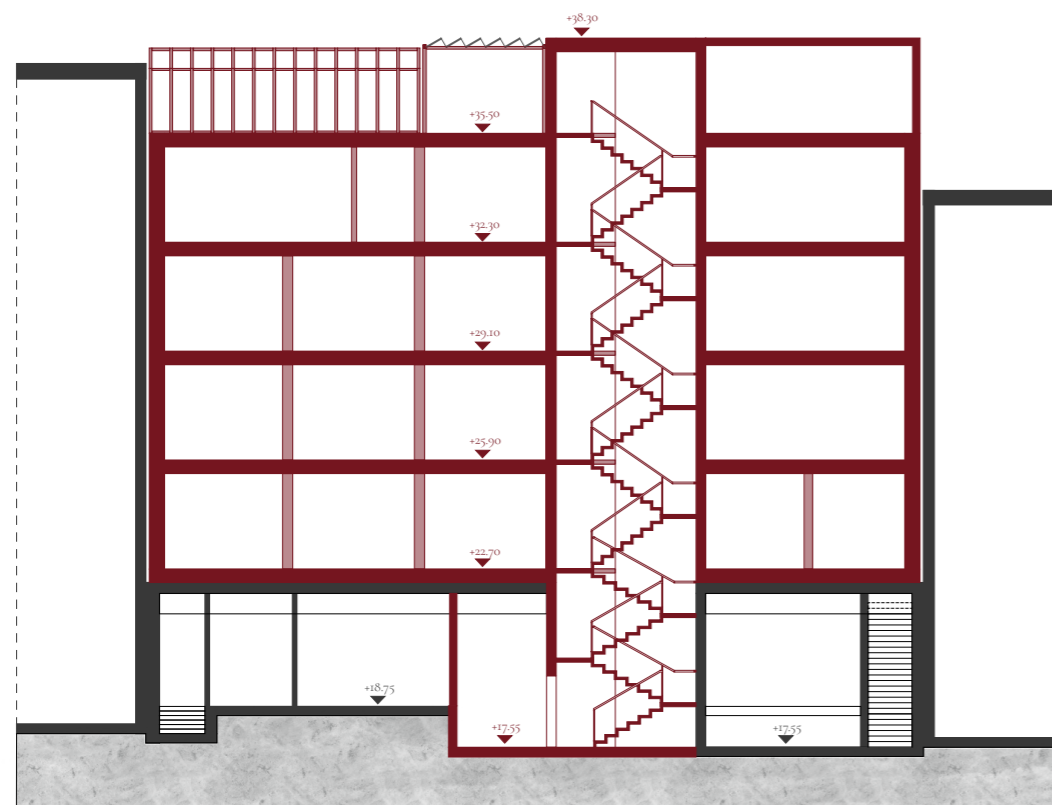

0 1 5 m Existing
Section B-B 1:200 New

By lowering the floor level to match the street level in the part where the new entrance is located, access to the new extension is provided. The ceiling height in the apartments are 2,8m giving a quite airy space even for the small typologies.

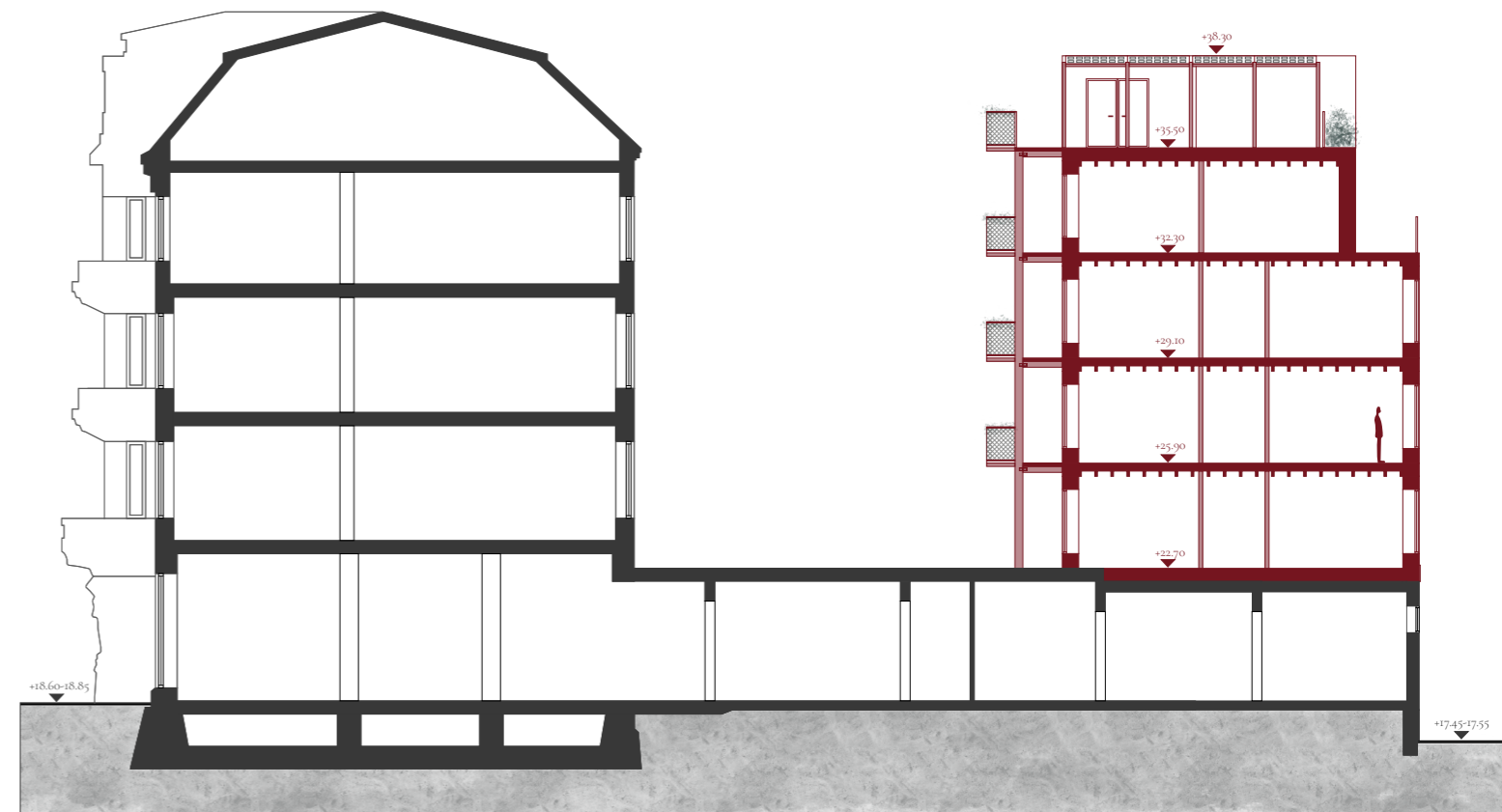

0 1 5 m Existing
Section C-C 1:200 New

By gradually stepping back the volume towards the street, a more humble and small-scale appearance of the building is achieved in the streetscape. This also gives private terraces to the apartments on the 4th floor and the 1m deep vegetation zone and the greenhouse on the roof contributes to the feeling of an oasis in the city and provides additional privacy to the terraces underneath.

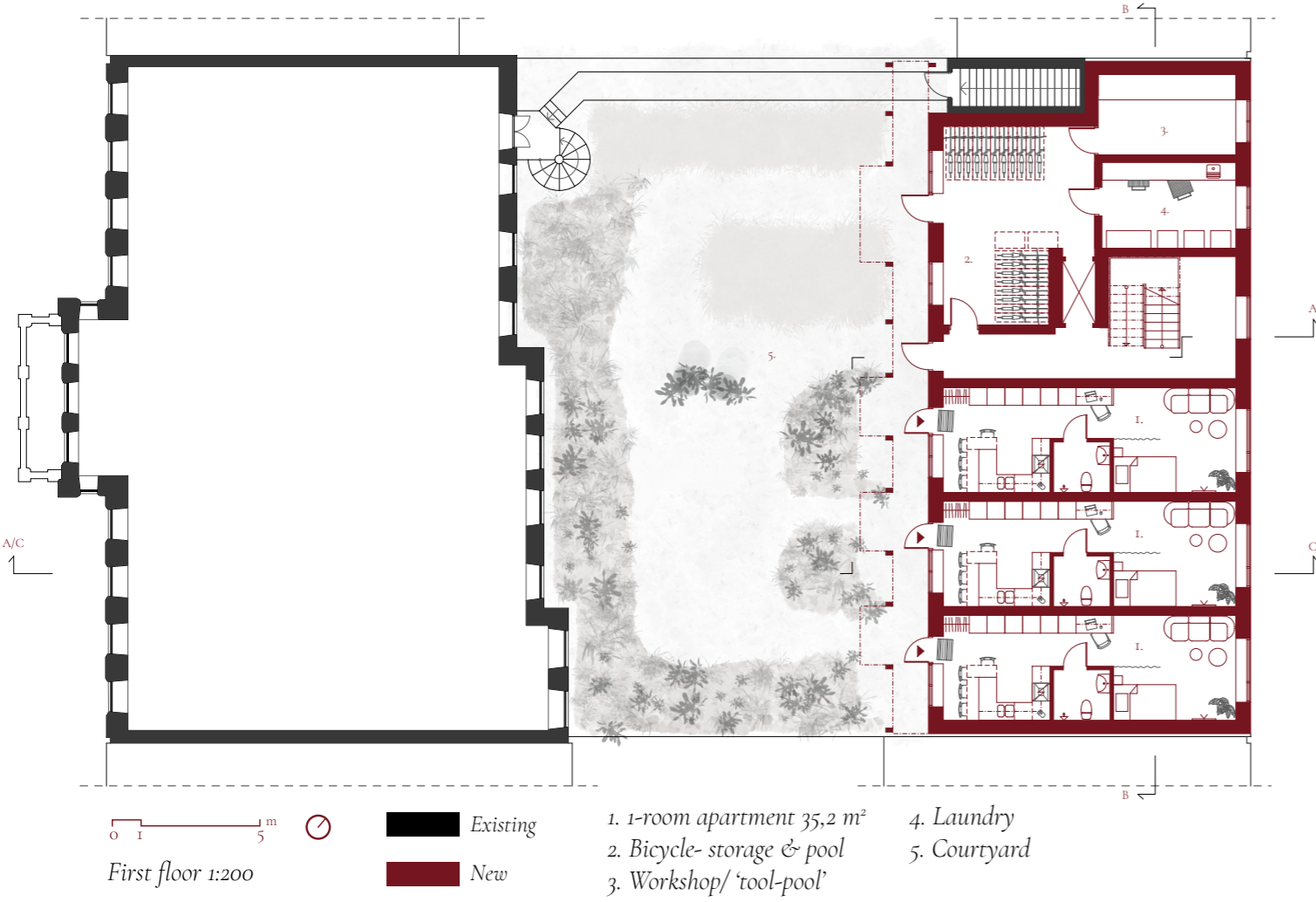
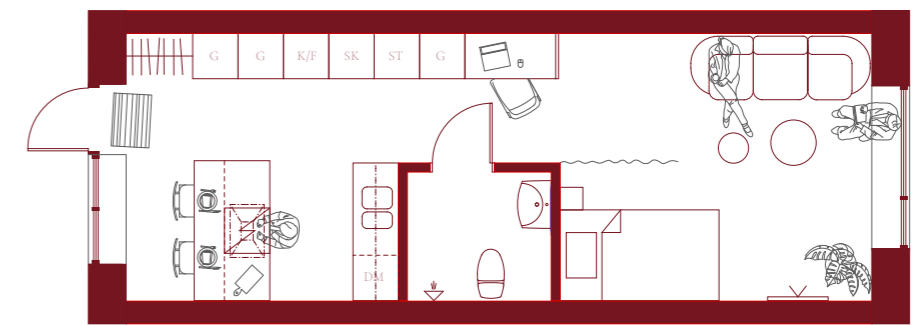
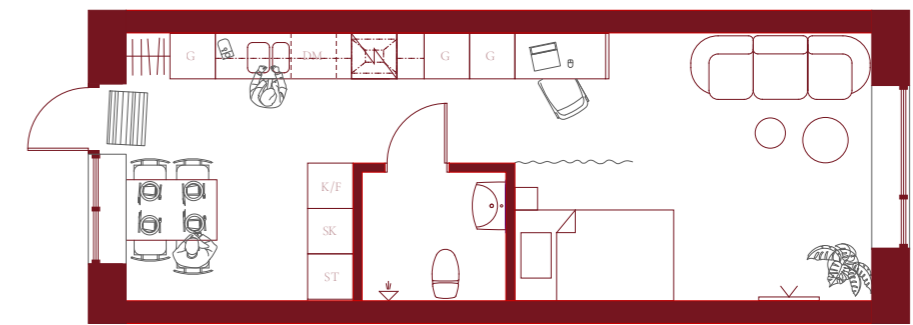
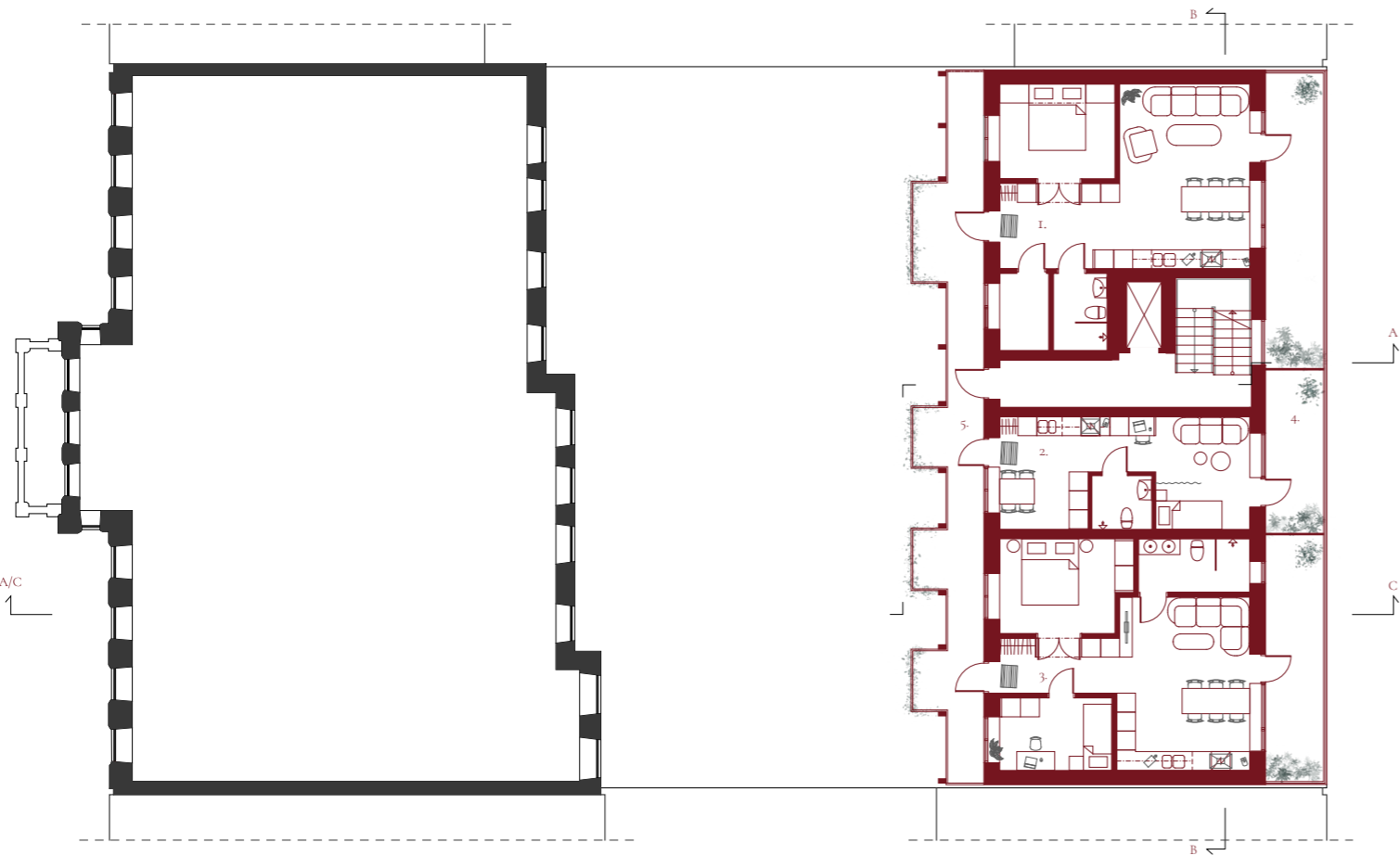

Figure 6: Exterior perspective (courtyard)



Alternative layouts for the 35,2 sqm 1-room apartment, 1:100



- 0 1 5 m
- Existing (black line)
New (red line)
- 1. 2,5-room apartment 55,5 m²
 - 2. 1-room apartment 28,9 m²
 - 3. 3-room apartment 58,5 m²
 - 4. Private terraces
 - 5. Entrance balcony
- 4th floor 1:200

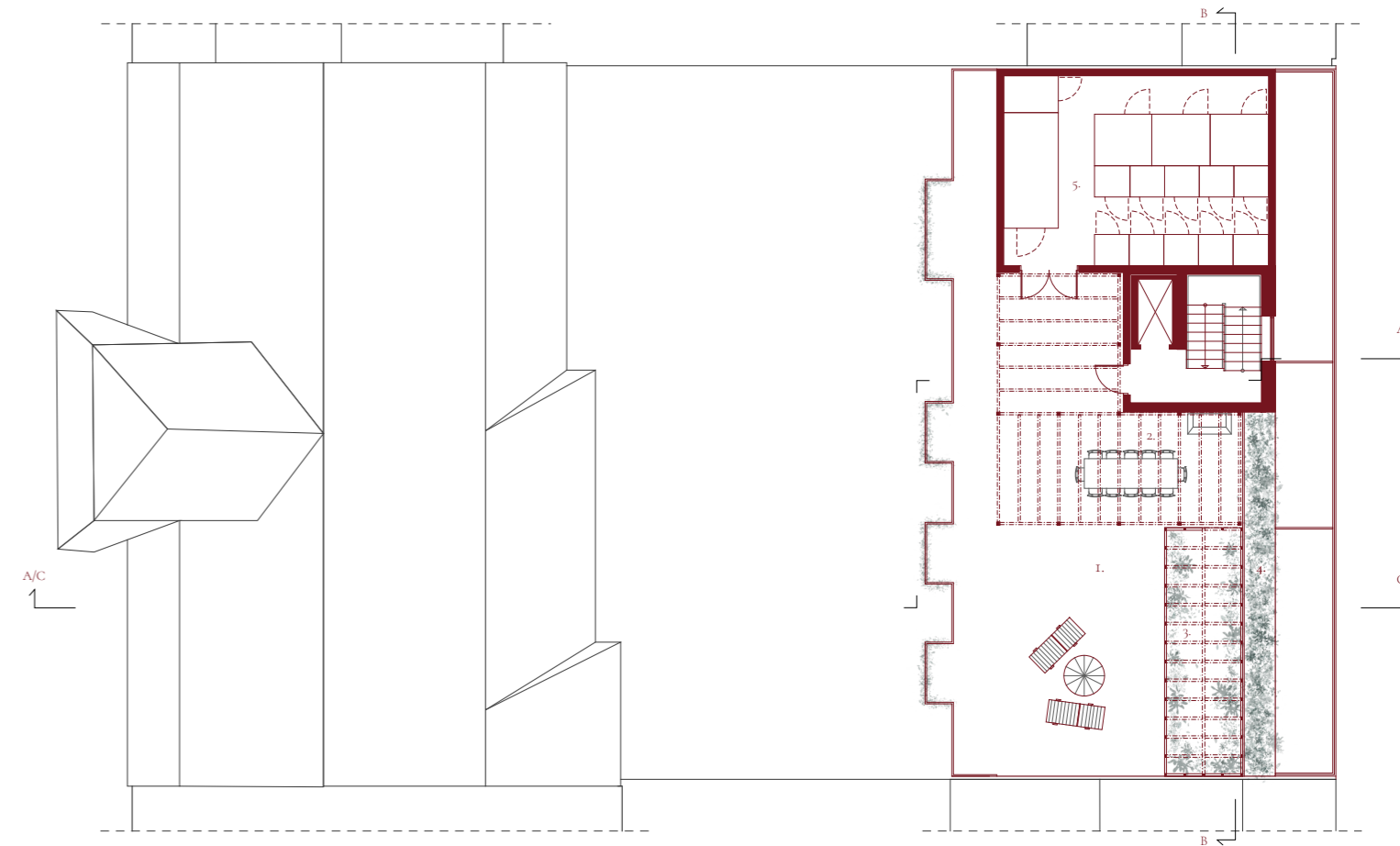

- 0 1 5 m
- Existing (black line)
New (red line)
- 1. Common roof terrace 150 m²
 - 2. Pergola & grill
 - 3. Greenhouse
 - 4. Vegetation zone
 - 5. Storages
 - 6. Solar panels on pergola- stairwell- and storage roof (approx. 120 m²)
- 5th floor/ roof 1:200

Roof terrace: The common space on the roof is a place for neighbors to meet, cultivate herbs and vegetables, enjoy the warmer days of the year and throw a barbecue together. From here you can overlook the roofscapes of the surrounding buildings and the pergola with PV's provides shading during sunny summer days.

4th floor:: Each of the apartments have access to a private terrace and the entrance balcony, extending the living-space during the warmer months. On the entrance balcony facing south-west residents can enjoy the sun even during colder periods, protected from precipitation and can inhabit the space as they wish.

Interior perspective: Inside the apartments the natural materials are highly present. Exposed ceiling beams, plywood ceiling, clay rendered walls and wooden floorboards in an earth-tone palette gives a calm atmosphere to the space. The window sill with a transparent polycarbonate cladding reveals the essence of the building & what its made of.



Figure 7: Interior perspective (1-room apartment 1st-3rd floor)

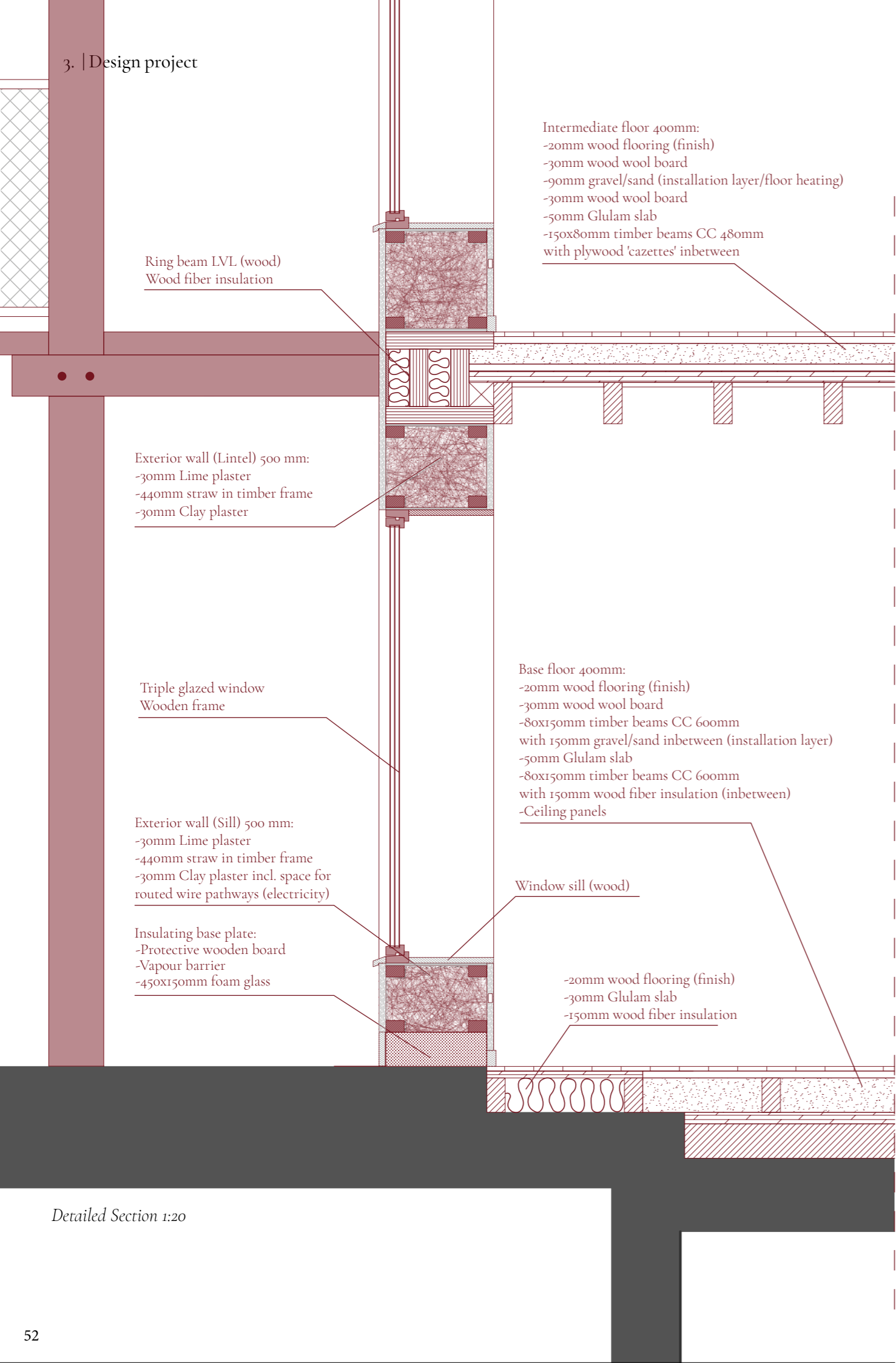

Detailed Section 1:20

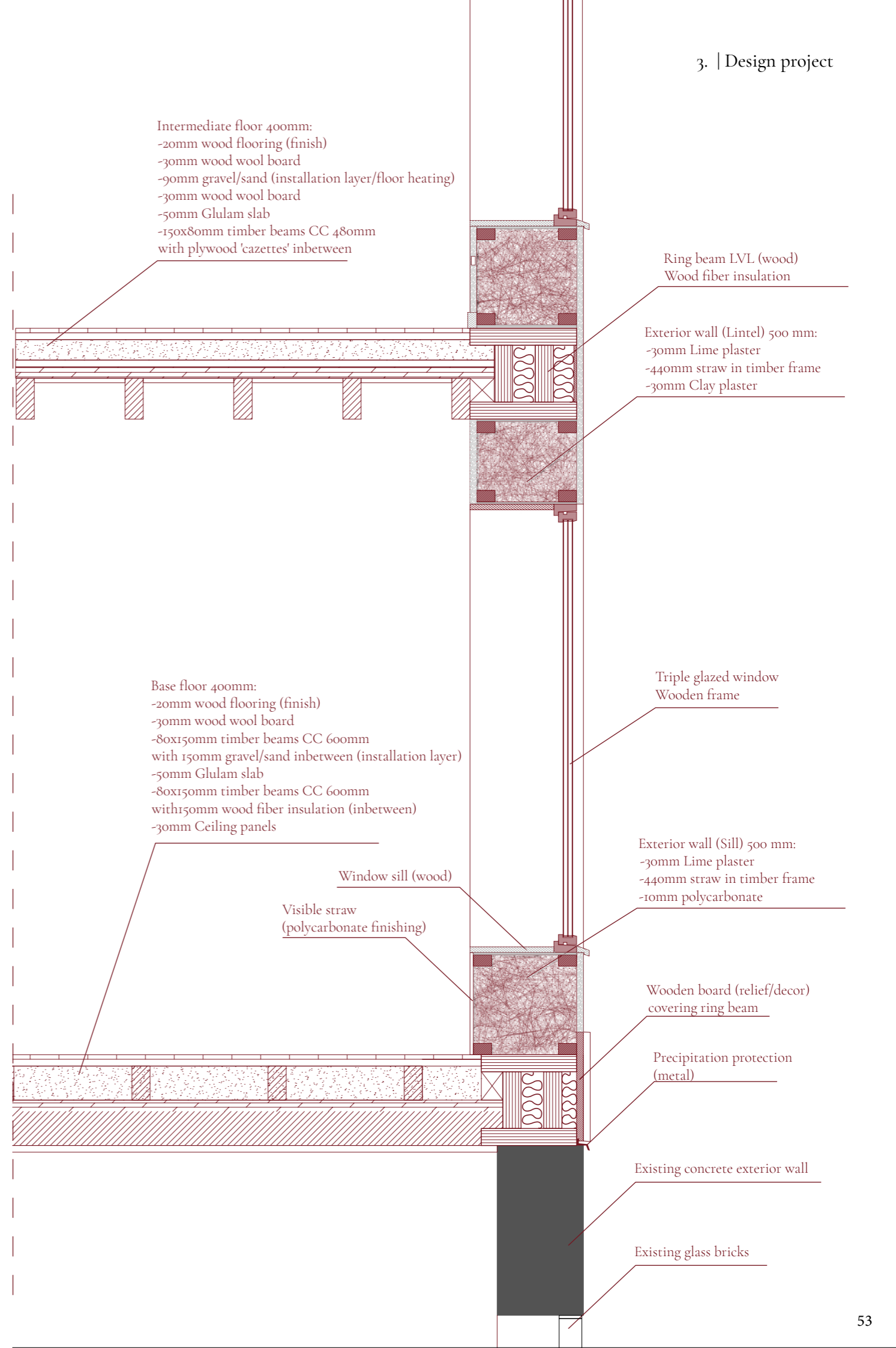

MATERIAL DISCUSSION

THE SELECTION OF MATERIALS

With the aim of reducing the buildings embodied energy and CO₂ with a main focus on straw in combination with wood as the structural and insulating material additional materials to complement the building has been mapped and selected. By studying built reference projects in combination with research on low-impact building materials, architectural visions and testing in CAALA the decisions were grounded and taken.

It has been of high importance to choose materials that are diffusion open in order to ensure a healthy indoor climate as well as right conditions for the straw walls to breathe, absorb and release humidity. This is important for them to not rot or decay. When this is done right straw walls have proven to last for over 100 years. The choice of cladding for the straw walls are earth-based lime render and clay render that excellent fulfill these requirements, but other viable options to choose from is wood fiber boards and wood paneling or vapor-permeable facade bricks. Choosing a wooden facade could actually have decreased the environmental impact a bit compared to using lime but would on the other hand require the use of more raw material because of the 60mm thick wood fiber panels that is needed in combination with a wooden facade and would of course have changed the architectural impression of the building.

The intermediate floors are composed of wood in combination with sand and gravel to achieve better sound-insulating properties and a more robust slab. In the gravel/sand layer installations can be made and floor heating is integrated.

Gypsum-boards has been completely avoided by using clay render interior, giving a more lively surface with more texture. In the bathrooms clay boards are used as structural sheathing for the surface finish tadelakt. This is an ancient technique used for over thousands of years in for example hamams and is a lime based render that is polished to harden it and finally treated with olive soap or beeswax, resulting in an water resistant surface. The material gets a stone-like feeling and appearance

and can be colored with pigments.

As a design choice as well as educational purpose some parts of the facade has been clad with transparent polycarbonate instead of the lime render in order to expose the straw, making it visible from the street and the surrounding buildings.

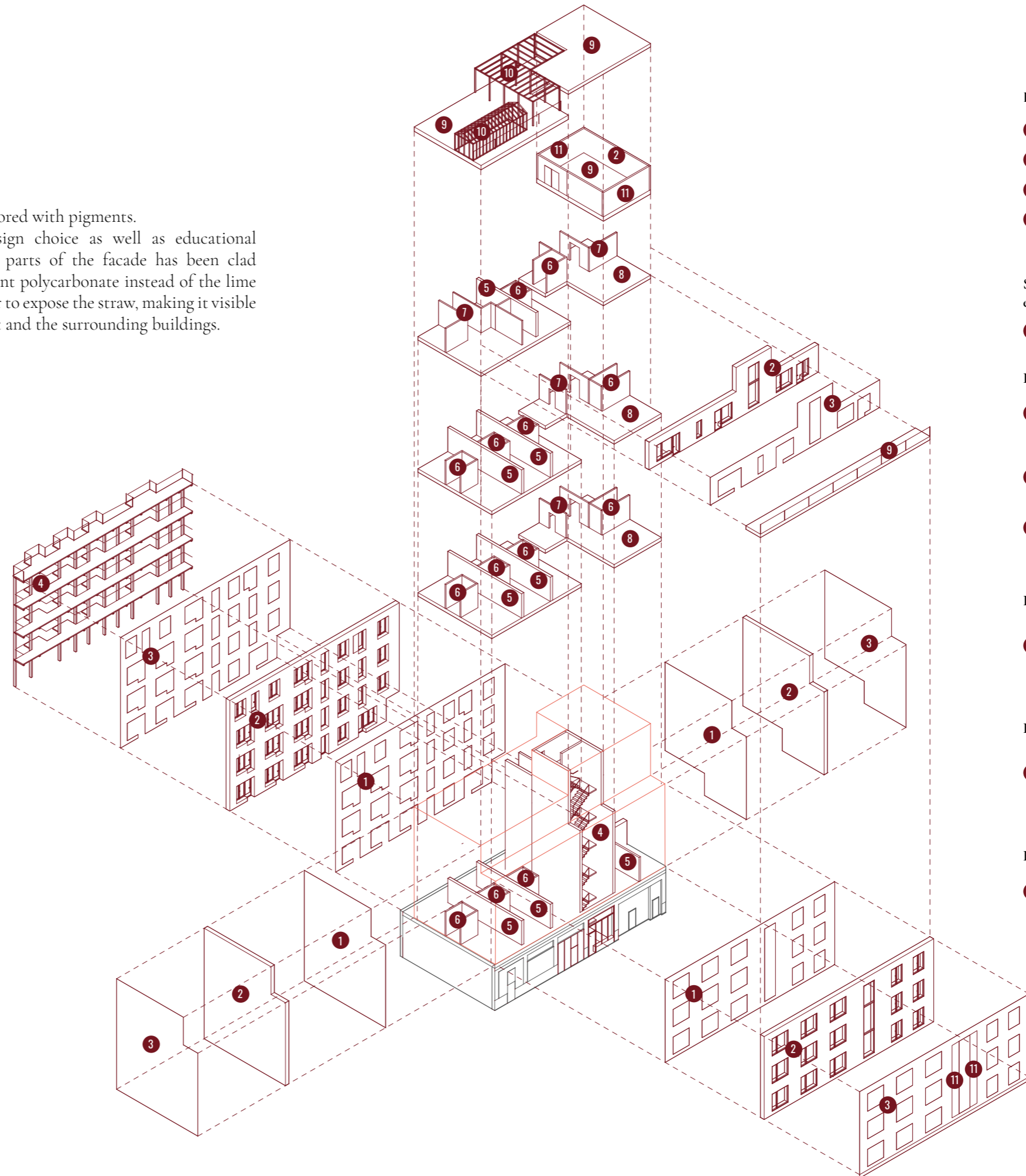

Exterior walls:

- 1 Clay render
- 2 Straw modules
- 3 Lime render
- 11 Polycarbonate facade (transparent)

Stairwell core & entrance balcony:

- 4 CLT (wood)

Interior walls:

- 5 Straw modules (apartment dividing walls)
- 6 Wooden stud walls, clay boards and interior tadelakt finish (bathrooms)
- 7 Wooden stud wall, wood fibre insulation, clay render (room dividing walls)

Intermediate floors:

- 8 Wooden joists, Glulam slab, gravel/sand fill, wood wool board & wood flooring

Roof:

- 9 Wooden joists, wood fibre insulation, sealinglayer (metal), wooden terrace floor where walkable area

Roof terrace pergola & greenhouse:

- 10 Timber

DAYLIGHT

SWEDISH DAYLIGHT REQUIREMENTS FOR HOUSING

Daylight factor (DF) is a way to measure the amount of daylight inside a building to make sure sufficient daylight can be guaranteed from a health-perspective in the parts of a home where people stay more than temporarily and is regulated in Boverkets Byggregler (BBR). This means that rooms for sleep/rest, cooking/eating and socializing is covered by the requirements whereas hygiene rooms, storages or shared facilities where people only stay temporarily don't have the same demands. The requirements for daylight in BBR is based on the requirements in Plan-och bygglagen (PBL) saying that a building must not originate risks for people's health. (Boverket, 2022).

There are different methods for measuring DF: as a mean-value for the measured area, median value or a value for a specific point located in the room. The value differs depending on which method that's employed but for the later one, measuring a set point in the room the requirement is to reach a DF of 1%, which is equivalent to a mean value of 1% for the total measured area. Other guidelines is that a good amount of daylight is achieved if more than 50% of the floor area has a DF of minimum 1%, or that the window area should be at least 10% of the floor area. (SBUF, 2018).

The standard SS-EN 17037 "Dagsljus i bostäder" recommend even higher values for housing with the aim that rooms should be perceived as light, but this is higher than required in BBR. (Boverket, 2022).

ANALYZING DAYLIGHT CONDITIONS IN VELUX

Throughout this design process multiple volumetric tests and apartment typologies have been analyzed with the program Velux Daylight Visualizer to evaluate qualities or deficiencies for the different options in terms of daylight as one of several parameters to guide the design. The tool has also later on been used to optimize the final design and ensure that all the apartments meet the Swedish requirement. The aim has been to achieve a median DF of minimum 1%, and a DF of 1% for

at least 50% of the apartment area, excluding the bathrooms.

When setting up the model a reference plane was used, offset 500mm in from all 4 apartment defining walls and on a height of +850mm from the floor level. The report from Velux compares the values (in % of the measured floor space that reaches certain DF target values) to the standard SS-EN 17037 which no longer is a requirement but still can be seen as an indicator of how the daylight situation in the specific apartment matches the higher aims for daylight in housing.

CONSEQUENCES/ IMPACT ON THE DESIGN

7 of the total 14 apartments were analyzed and chosen by the criteria: poorest daylight conditions, best conditions and some in between. Two apartments on the lowest (1st) floor were tested, as they are the most critical ones to achieve sufficient daylight for. From these tests I concluded that in addition to the windows, which had already been increased in size throughout the whole building, the entrance doors needed to be partially glazed too in order to achieve sufficient daylight on the side facing the courtyard. Furthermore two apartments on the second floor and two on the fourth floor were tested which naturally could achieve higher values of daylight factors since they're located higher up in the building. On the 4th floor where the apartments are shallower than on the floors below due to the push-back of the facade with terraces there might rather be a potential risk of overheating and/or glare which could be solved by external or internal sun shading, but this would require further analyzes and lies outside the framework of this thesis. The apartments on the 3rd floor were not tested since the sufficiency of them could be proved based on the sufficient results on the 2nd floor. The final daylight simulation report shows that the median value for the tested apartments span from 1.11%-3.42%.

Zone 01A - 35,2 m² apartment on 1st floor

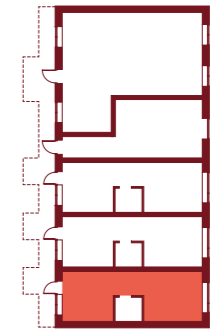

Zone 02B - 35,2 m² apartment on 2nd floor

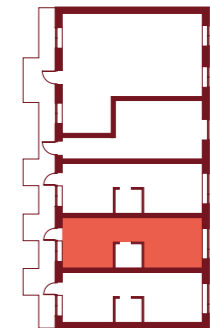

Zone 02D - 67,2 m² apartment on 2nd floor

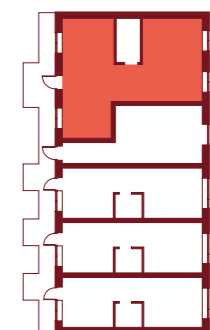
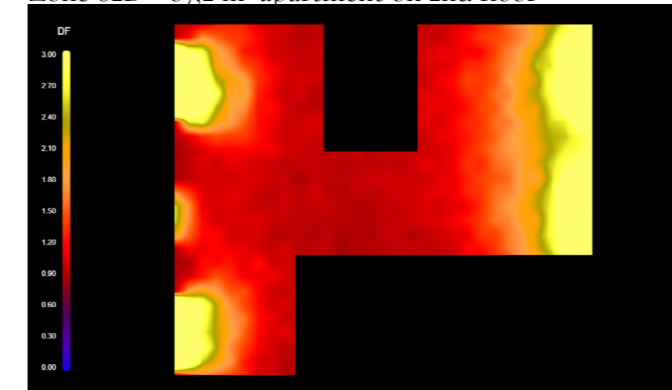

zone 04B - 28,9 m² apartment on 4th floor

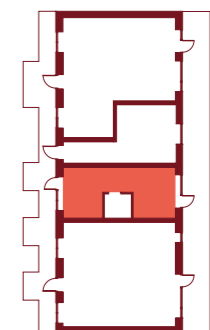

ENVIRONMENTAL IMPACT -LCA

ANALYZING THE ENVIRONMENTAL IMPACT OF THE DESIGN

As an evaluation tool as well as a guiding tool throughout the design process the program CAALA has been used to measure the climate impact of the design through a Life cycle assessment (LCA). By first testing different volumetric alternatives in the “Preliminary planning” phase in CAALA (where you exclude the interior walls and doors) the results showed some initial numbers for Primary energy demand and Global Warming potential (GWP) which could be used as an indicator for the following design process. The program was, in this project, not intended to primarily be used as a guiding tool to optimize the design of the volume or the apartment typologies/floor plan layout, but rather for testing and optimizing the choice of materials and constructions for the final design option.

In the final LCA analysis a more comprehensive analyze was carried out in CAALA in the “Blueprint planning” phase, where also the interior walls and doors are included. Additionally, I wanted to be able to compare the results from the LCA with conventional construction materials and therefore made an analysis for the exact same geometry, replacing it with conventional materials such as structural concrete with a brick facade, mineral wool- and plastic (EPS) insulation. Some materials and parameters were fixed and the same in both versions, such as triple glazed windows with a U-value of 0.7, door materials, district heating as energy source as well as thermal bridges- and air tightness settings for the building envelope. By doing this it became possible to compare the numbers and easier put it into its context to see the actual differences in environmental impact. The conventional building was used as the baseline scenario which the straw building was then compared to.

FULL LCA VS. FOCUS AREAS OF ASSESSMENT

A full LCA in CAALA consists of multiple different ‘modules’ that takes into consideration the different phases in a buildings lifetime from material production including raw material extraction

(module A1-A3) to the final waste treatment and disposal (module C3-C4). Replacements of components when their service life has reached an end (module B4) and energy demand during operation (module B6) is also included. Other, optional, parameters can also be included such as future scenarios which may include burdens or benefits from reuse or recycling of the building materials after the end of life cycle (D1) or electricity generated from PV’s on the building that is exported to the national grid (D2). Benefits or loads from module D1 or D2 doesn’t affect the current buildings results within its system boundary since the effects are considered to be outside the system boundary, thus the benefits from e.g. reusing the wall elements would accrue to the next building, resulting in lower impact in that buildings production phase(A1-A3).

CHOSEN METHODS AND FOCUS FOR THIS THESIS

For this LCA three different comprehensive comparisons with different focuses was formulated and tested where A) is the first assessment to be presented and also the most comprehensive one, followed by B) that in the best way shows the results according to the focus of this thesis, and finally C) which is a less comprehensive LCA. The three comparisons was:

A) A full analyze including all the modules (A1-A3, B4, B6, C3+C4, D1, D2).

B) is focused on the full life-cycle of the materials and excludes module B6 & D2 (‘Energy demand in use phase’ and ‘Benefits from exported energy’) and thereby also puts the focus on the impact of the materials, but not the operational or produced energy. This alternative gives a good indicator on how the material choices specifically impact the environment through its whole life-cycle.

C) is focused on the impact of extracting/producing the materials, including replacements and potential benefits from recovery outside the system boundaries as well as the energy performance of the building in use phase and benefits from

exported energy, but excludes C3+C4 (End-of-life phase). This option was formulated to get a focused analysis specifically on the differences in material impact without considering the impact/CO₂ that’s released from the materials in the end-of-life phase since it is a debated topic whether the biogenic CO₂ in biomass should be counted as emission or a part of the constant flow in the biogenic carbon cycle. However, this can be considered a less scientifically correct comparison since it only counts the benefits/burdens in the production and operational phase and excludes the consequences in the end-of-life which tends to clearly reward bio-materials and result in an overly optimistic calculation. Having that said, this comparison was still tested since the thesis is about using residual straw as building material, which works as a carbon storage in the building instead of immediately decomposing or burning it, releasing all the stored CO₂ back into the atmosphere or even worse, extract virgin materials for new materials and process them using energy-intensive processes or fossil fuel.

RESULTS FROM THE LIFE CYCLE ASSESSMENT

The report from the full LCA (A) shows that the straw building results in a decreased GWP of -203% in the production phase whilst the overall total decrease in GWP is -29.7% due to the significant higher estimated impact in the end of life phase(C3+C4) for the bio-based building. Additionally, the results show a decrease of -49.9% in Primary energy Non-Renewable Total (PENRT) for the production phase. The decrease in GWP from Greenhouse gases in case of recycling (D1, outside the buildings system boundaries) is -289.5%, whilst if the material go to end-of-life the GWP for the straw building instead result in a significant increase of +898.8% compared to the concrete building. On the next page the results from comparison B and C is presented, showing a more focused analysis of the impact from the materials itself which is the best representation for this thesis focus.

LCA RESULTS FROM COMPARISON A:

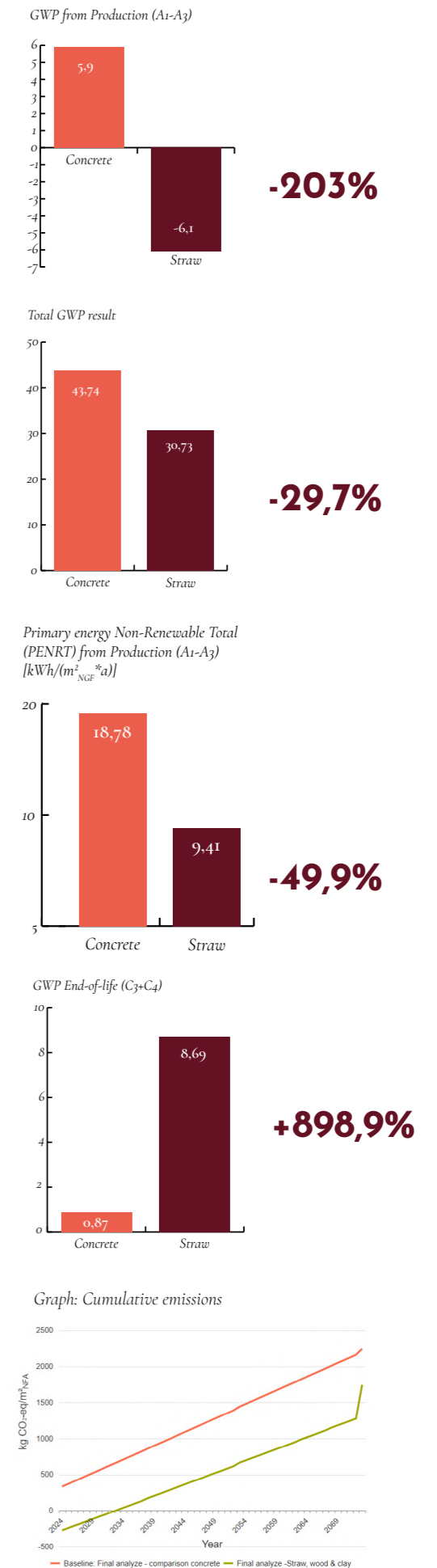

Comparison B includes the production, replacements, end-of-life and benefits/burdens from reuse or recycling of building materials after the end of the buildings life cycle. It shows that the straw building results in a decreased GWP from production of -198,4% compared to the conventional building and an overall total decrease in GWP of -105,8% and has a negative total Global Warming Potential result of -0,42 which means the building actually is a carbon sink. This result is based on the sum of the stored CO₂ accounted for in the production phase plus the CO₂ emissions from end-of-life phase and replacements, minus the greenhouse gas potential recycling from outside the buildings system boundaries (if benefits/burdens from outside the system boundaries is turned off both of the buildings are NET+ emitters with a GWP of 4,22 for the straw building, a decrease of 50,4% compared to the concrete building with a GWP of 8,51). Additionally, the results show a -46,1% decrease in Primary energy Non-Renewable Total (PENRT) for the production phase, a slightly lower (3,8%) decrease compared to in comparison A.

The decrease in GWP from Greenhouse gases in case of recycling (D1, outside the buildings system boundaries) is -286,7%, whilst if the material go to end-of-life the GWP for the straw building instead result in an increase of +884,2% compared to the concrete building, these numbers are very similar to the ones in comparison A.

Comparison C without the end-of-life phase shows an even more significant difference between the conventional materials and the straw building. This is evident in the Total GWP result where the straw building has 272,5% lower impact than the conventional one and a negative result of -10,71 meaning the building is a distinct carbon sink.

LCA RESULTS FROM COMPARISON B:

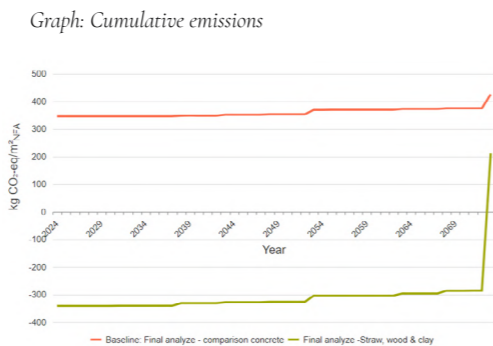
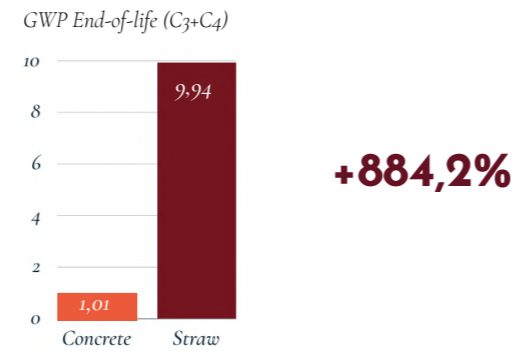
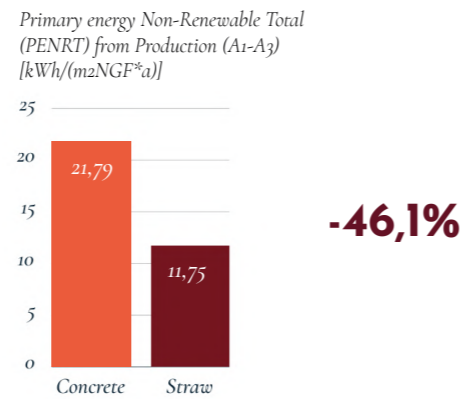
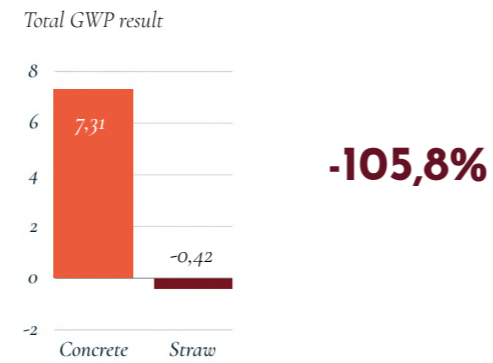
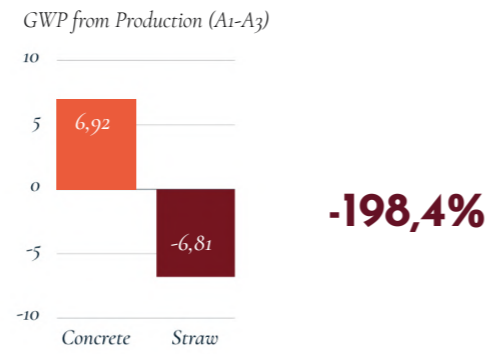

LCA RESULTS FROM COMPARISON C:

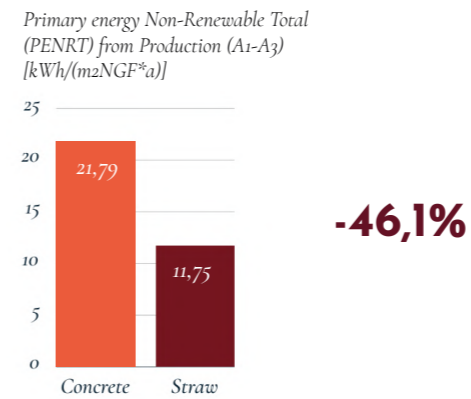
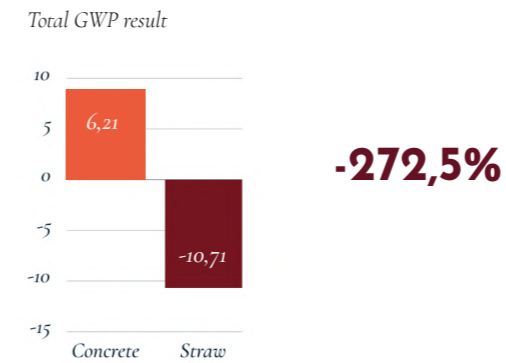
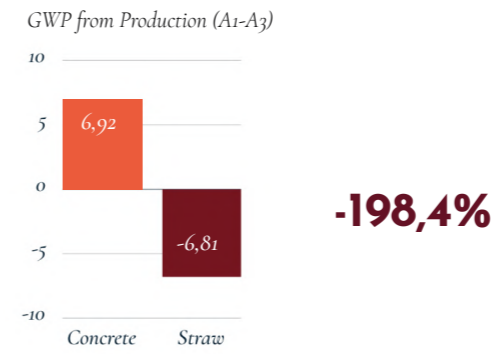

GWP End-of-life (C3+C4)
Not measured

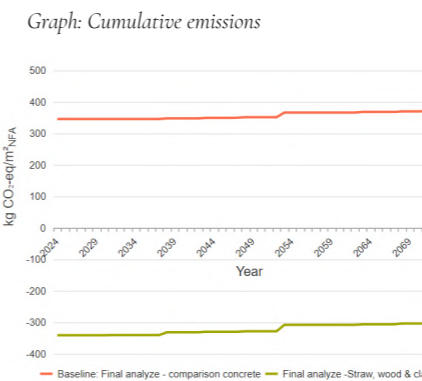

4.

DISCUSSION & REFERENCES

- Discussion & Conclusion
- List of References

DISCUSSION & CONCLUSION

THESIS SUBJECTS & RESULTS

That fact that we drastically need to reduce the environmental degradation and climate change caused by the building industry is evident. The solutions can be found in multiple strategies that might vary depending on local conditions such as resources, knowledge and economy. Shifting from high-impact materials to “low-tech” and low-impact materials is one of them, and I believe there’s a lot to gain from historical retrospects, looking at how we built houses before with local materials and techniques, if we also take the learnings from the past and transfer the knowledge, adapting it to the present and future.

If this approach is combined with technological optimization and development of materials, energy and transportation the impact would be even greater, and could potentially work as a road map for the building industry in the future. This must also be supported by a circular economy where life-cycles are extended and resources are valued higher. There lies the interesting aspect of making use of residual straw from the agriculture and up-cycle it for a industry where we need to take urgent actions. The research as well as the results from the LCA clearly highlighted that straw is an efficient and fast-growing CO₂ sequester, containing as much as 40-50% of its mass in carbon, and that burning or decomposing the material releases it into the atmosphere once again which should be avoided as far as possible.

Since straw is still an underutilized material for building in an urban context, especially in Sweden, this project could contribute to dissemination of knowledge and highlight the potential with- and gains of building efficient and environmental conscious with “urban straw” to reduce the shortage of housing in urban areas. With the process of prefabrication the material can reach out to a larger mass, and thereby contribute to a more large scale positive change.

The findings from this thesis shows that as a smaller actor and producer in Sweden there’s not enough general demand or financial support from

the state at the moment which would facilitate an expansion, standardization and certification of the prefab-production. The result of such support could enhance the credibility and acceptance of the material and thereby the interest for building with it. However, I do believe the knowledge and interest in Europe in general and in the Nordic countries especially is increasing and that this development will be seen also in Sweden within the upcoming years, but in order for that to happen we must make sure that key-stakeholders and decision makers are on board to shift from conventional practices to more sustainable ones.

The results from the LCA’s that was carried out in the program CAALA during this process should be seen as guiding values and an indicator, rather than exact numbers, of the climate impact from our material choices. There were some bugs/glitches experienced when using the program resulting in shifting values from time to time and numbers that increased along the process even though no changes were made to the input data, leaving a certain margin of error to the LCA results. Additionally the LCA reference study period was set to 50 years which is a common period to measure, however, in this case a 100 year reference study period might have been more beneficial and realistic since straw structures has proven to stand for 100+ years.

The environmental benefits of specifically replacing conventional, carbon- and energy intense building materials to bio-based, residual and low-processed materials shows best in the LCA analysis ‘B’ where module B6 (“Energy demand in use phase”) is switched of. In this way the GWP results shows a focused comparison of the impact specifically from the material choices, excluding the more static impact from the operative energy use. This shows a more significant difference between the conventional- and bio-based building percentage wise, but still include some parameters that have equal and unavoidable environmental impact in both buildings such as production and replacement of windows and doors (which are the same types).

If these were to be excluded the comparison would be even more focused on the structural and insulating materials itself but evidentially isn't a holistic approach in terms of LCA.

The LCA without module B6 shows that the concrete building has a GWP value of 8,51 whilst the straw/wood building has a value of 4,22. This is a reduction of 50.4% in GWP, a significant reduction of environmental impact. Furthermore, if module D1 ("Benefits from recovery outside the system boundaries") is included in the LCA the results show an even more significant reduction in environmental impact for the straw building. The GWP value for the concrete building in this case is 7,31 whilst for the straw building the GWP is -0,42, a reduction of 105,8%. The GWP for "End-of-life" (C3+C4) still shows a significant distinction between the two buildings where the straw building has a value of 9,94, 884% higher than the concrete building with a value of 1,01. These analyzes highlights the comprehensiveness of the LCA tools which in one way could be considered to generate a holistic assessment of a buildings impact, but on the other hand, according to me, diminishes and subordinate the importance of taking immediate action towards climate change. Because of this, comparison C is a relevant analyze to do, despite its incompleteness and focused lens. I believe that locking in" carbon in the building stock is one of many efficient and necessary strategies to implement in order to soon reach a turning point and finally the net-zero goal set for 2050.

This leads to the topic of biogenic- vs fossil carbon and the "carbon cycle". The difference between fossil carbon and biogenic carbon is that emissions from fossil carbon adds carbon to the biosphere-atmosphere that has been buried in the ground for millions of years resulting in an accelerated warming process, unlike biogenic carbon that is in a circular cycle, sequestered and released by biological matter. Burning of fossil fuels, extraction of cement and clearing of land are some of the anthropogenic actions that perturb the natural carbon cycle and

speed up the warming process. Deforestation in favor of replacing carbon intense building materials for example leads to reduced areas of carbon storing plants which has a long "payback period", up to decades, whilst the more fast growing crops/plants may be a better alternative to promptly break the global warming and its irreversible consequences by utilizing buildings as a "carbon bank".

The purpose of this project and comparison is not to blacklist or reject the use of concrete. It rather aims to suggest and encourage a smarter and more conscious choice of materials to not routinely stick to conventions or "business as usual" practices. "Right material in the right place" one could say, using heavy and structurally sound concrete when absolutely needed and deselect it in favor of bio-based low-impact materials whenever possible.

For urban re-densification/vertical extension projects, the material should be relatively light-weight to rest on top of existing structures and for this straw is a viable option (even though each specific case must be assessed and calculated in terms of loads). In this project the structural loads of the new addition was not calculated and assumptions where made that some reinforcements/additional support pillars in the existing structure might be necessary. Estimations in this thesis based on quick calculations of straws sequestration potential multiplied with the m2 of straw walls in the building showed that this 4,5 storey building would "lock up" approximately 76 tons of sequestered CO₂. If vertical densification with straw were to be implemented in a larger scale in Gothenburg by for example adding 1-2 storeys on flat roofscapes, it would result in a huge positive environmental impact as well as generate more housing in an efficient way.

THESIS QUESTIONS, PROCESS & METHOD

While doing this thesis two main aims have been central: 1. to deepen my knowledge about straw as a building material in the search of more sustainable and alternative practices for my future career and 2. to learn how the material works construction-wise and how to design a building with prefabricated straw-panels.

The design project was used as a test-bed for ideas and implementation of gathered knowledge and trough that I gained insights and knowledge about the opportunities and challenges connected to designing with prefabricated straw modules. To work with an existing building and its context was helpful in the sense that it gave me a clear framework and some set parameters to work with, guiding me forward in the process together with continuous research and analyses. This of course influenced the final design which to a certain extent is site specific and would have looked different on another site and context. However the main learnings about how the walls are composed and protected from rot or fire, how the current preconditions and prospects look for straw building in a Swedish context and how installations are incorporated are some of the more generic knowledge gained that can be applied to other straw projects as well.

Some of the design related constraints/challenges I was facing during the process was that the straw wall shouldn't be placed directly to the gable wall of the adjacent building since that may cause moisture issues and rot. The solution to this was to offset the two exterior straw gable walls by 100 mm from the existing building, creating an ventilated and precipitation protected air gap. This is a solution that, if built, would need further development and analysis in collaboration with a building physicist and since the facade wouldn't be reachable in this gap, another more durable and maintenance free material than lime render would probably be more feasible such as vapor-permeable facade bricks. A reflection made on the material choices in terms of the lime render as the facade material is that it reduces the positive climate

impact of the exterior straw walls (as can be seen in the LCA report in the appendix). This is due to the impact from the production and the estimated intervals for replacements of the lime render which has a negative environmental impact. When I tested to change the facade material for some of the walls to wood in CAALA the GWP result for the exterior straw walls improved, but not the overall GWP result, and if this was observed earlier in the process I might have developed the design and elevations with a wooden facade instead. However I decided to go with the plastered facade since I considered it to in a better way have a dialogue with the existing buildings in the area. It would be interesting though to make another iteration of this design with a wooden facade and see how the LCA results and architectural expression would change.

Another insight gained was that the design of the facade and placement of windows to some extent is influenced by the measurements of the panels, which needs to have certain dimensions in order to have their structural stability. This, on the other hand, can of course be compensated for by "acupunctural solutions" for these parts where other materials can be implemented as a sort of hybrid construction. In my case I wanted to stick to solely a prefab-straw exterior wall and therefore worked with the preconditions it brought.

It was important to me to give the project and myself the freedom to speculate, go beyond conventions and by doing that bring the low-tech material into the urban context as a way to explore and exhibit the potentials with it, but also to encourage a discussion about its future potential. I hope to get the opportunity to work more with this material and technique in the future and I also hope that we soon will see straw buildings appearing in the cityscapes of Swedish cities, buildings that adds new annual rings to the urban environments, encapsulating both the history and the future (and CO₂).

REFERENCES

Badh, F. (2022) *Kulturmiljöutredning Kvarteren omkring Lorensbergsgatan; Inom projektet Detaljplan för bostäder och kontor inom Lorensberg 53:3, 55:8 m.fl. inom stadsdelen Lorensberg.* (Kulturmiljörapport 2022, nr 02). Göteborgs Stadsmuseum. https://samlingar.goteborgsstadsmuseum.se/carlotta/digitalt_dokument/web/image/blob/2216012/Kulturmilj%C3%B6rapport%202022_02.pdf

Björnsson, L., Prade, T. (2021). *Sustainable Cereal Straw Management: Use as Feedstock for Emerging Biobased Industries or Cropland Soil Incorporation?*. Waste Biomass Valor 12, 5649–5663. <https://doi.org/10.1007/s12649-021-01419-9>

Boverket. (2022, 11 mars). *Dagsljus*. <https://www.boverket.se/sv/PBL-kunskapsbanken/regler-om-byggande/boverkets-byggregler/ljus-i-byggnader/dagsljus/>

Boverket. (2023). *Läget på bostadsmarknaden i riket*. <https://www.boverket.se/sv/samhallsplanering/bostadsmarknad/bostadsmarknaden/bostadsmarknadsenkaten/region-kommun/riket/>

Boverket. (2024). *Fortsatt underskott på bostadsmarknaden i storstadsregionerna*. <https://www.boverket.se/sv/samhallsplanering/bostadsmarknad/bostadsmarknaden/bostadsmarknadsenkaten/region-kommun/storstadsregionerna/>

Carcassi, O. B., Habert, G., Malighetti, L. E., & Pittau, F. (2022). *Material Diets for Climate-Neutral Construction*. Environmental science & technology, 56(8), 5213–5223. <https://doi.org/10.1021/acs.est.1c05895>

Deplazes, A. (red.) (2018). *Constructing architecture: materials, processes, structures*. (Fourth, revised edition.) Basel: Birkhäuser.

EcoCocon. (2023). *Technical Specifications*. [Product sheet]. <https://ecococon.eu/assets/downloads/ecococon-technical-specifications.pdf>

Fastighetskontoret, Göteborgs stad. (2022). *Lägesrapport 2022 bostadsförsörjning*. <https://goteborg.se/wps/wcm/connect/9c081eb3-6518-4357-bfda-200c96edd37a/Bostadsf%C3%B6rs%C3%B6rjning-i-G%C3%B6teborg-1%C3%A4gesrapport-2018.pdf?MOD=AJPERES>

Jones, B. (2015). *Building with straw bales: a practical manual for self-builders and architects*. (Third revised and expanded edition.) Cambridge, England: Green Books.

MacMath, R., Fisk, P. (2000). *CARBON DIOXIDE INTENSITY RATIOS: A Method of Evaluating the Upstream Global Warming Impact of Long-Life Building Materials*. https://www.researchgate.net/publication/238116420_CARBON_DIOXIDE_INTENSITY_RATIOS_A_Method_of_Evaluating_the_Upstream_Global_Warming_Impact_of_Long-Life_Building_Materials

Magwood, C. (2016). *Essential prefab straw bale construction: the complete step-by-step guide*. Gabriola [British Columbia]: New Society Publishers.

Nilsson, D & Bernesson, S. (2009). *Straw as fuel -Part 1: Available resources and harvest times (Report 011)*. [Report, SLU department of Energy and Technology]. https://pub.epsilon.slu.se/4854/1/nilsson_d_et_al_100630.pdf

UN. (2022) *The sustainable development goals report 2022*. <https://unstats.un.org/sdgs/report/2022/The-Sustainable-Development-Goals-Report-2022.pdf>

United Nations Environment Programme. (2023). *Building Materials and the Climate: Constructing a New Future*. <https://wedocs.unep.org/20.500.11822/43293>.

SBUF. (2018). *Moderniserad dagsljusstandard* (SBUF ID: 13209). <https://www.bau.se/wp-content/uploads/2018/12/SBUF-13209-Slutrapport-Moderniserad-dagsljusstandard.pdf>

IMAGES & GRAPHICAL MATERIAL

Figure 3: MacMath, R., Fisk, P. (2000). *Carbon Dioxide Intensity Ratios [Diagram]*. Researchgate. https://www.researchgate.net/publication/238116420_CARBON_DIOXIDE_INTENSITY_RATIOS_A_Method_of_Evaluating_the_Upstream_Global_Warming_Impact_of_Long-Life_Building_Materials

Figure 6: Scale humans in collage from studioalternativi.com. Product creators: Maria Laura Manrique (Ilustramery), Noel Florance (RIGA ilustraciones), Sinem & Danae (Archbuddies)

Figure 7: Scale humans in collage from studioalternativi.com. Product creator: Noel Florance (RIGA ilustraciones)

Images Karper! : Hé Architectuur. (n.d). *Karper!*. Retrieved January 24th 2024, from <https://he-architectuur.be/karper-1>

Images LILAC : ModCell (n.d). LILAC affordable ecological co-housing. Retrieved May 19th 2024, from <https://www.modcell.com/projects/lilac-affordable-ecological-co-housing/>

(All figures/photographs excluded in this list is the authors own work)

APPENDIX

TABLE OF CONTENTS:

Velux Daylight simulation report.....69-74
 01 Apartments on 1st floor.....69
 02 Apartments on 2nd floor.....71
 03 Apartments on 4th floor.....73
 CAALA Environmental impact report.....75-89
 04 CAALA - Screenshots of 3D-model.....75
 05 CAALA LCA/ Summary of report (B).....76
 06 CAALA LCA/ Summary of report (C).....78
 07 CAALA LCA/ Extended summary of report (A).....80

VELUX DAYLIGHT REPORT

APARTMENTS ON 1ST FLOOR

Daylight Visualizer

Calculation on zones

Project name: untitled
 Simulation type: Daylight Factor
 Daylight Visualizer version: 3.1

Select Country

Sweden

Select Report Options

- EN17037
- Active House
- Fractions of Work Planes
- Percentiles

EN17037 For Sweden the target daylight factors (D_T) are 2.5% (300 lux), 4.1% (500 lux) and 6.2% (750 lux). The minimum daylight factor target (D_{TM}) is 0.8% (100 lux). The standard is available for purchase from the National Standardization Body in your country.

w_zone 01 A

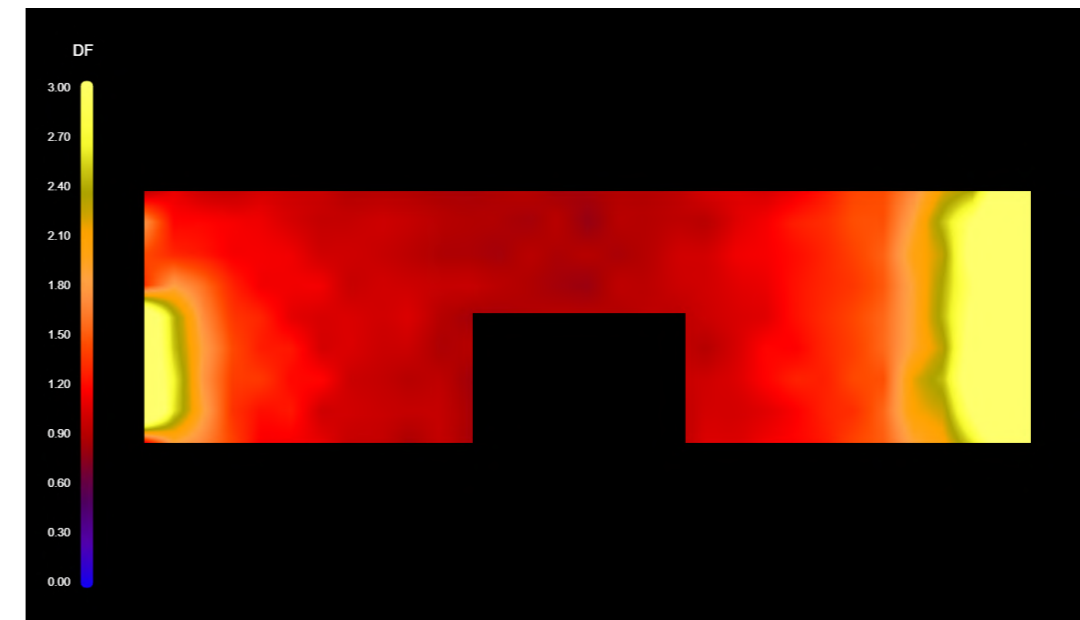

Average	D	1.61%
Median	D	1.15%
Minimum	D	0.80%
Maximum	D	6.84%
Uniformity 1	D_{min}/D_{avg}	0.4956
Uniformity 2	D_{min}/D_{max}	0.1164

EN17037

$F_{plane, \%} \geq 0.8\% D_{TM}$	100%	Pass ($\geq 95\%$)
$F_{plane, \%} \geq 2.5\% D_T$	13%	Fail ($< 50\%$)
$F_{plane, \%} \geq 4.1\% D_T$	6%	Fail ($< 50\%$)
$F_{plane, \%} \geq 6.2\% D_T$	1%	Fail ($< 50\%$)

APARTMENTS ON 2ND FLOOR

Daylight Visualizer

Calculation on zones

Project name: untitled
 Simulation type: Daylight Factor
 Daylight Visualizer version: 3.1

Select Country

Sweden

Select Report Options

- EN17037
- Active House
- Fractions of Work Planes
- Percentiles

EN17037 For Sweden the target daylight factors (D_T) are 2.5% (300 lux), 4.1% (500 lux) and 6.2% (750 lux). The minimum daylight factor target (D_{TM}) is 0.8% (100 lux). The standard is available for purchase from the National Standardization Body in your country.

w_zone 01 B

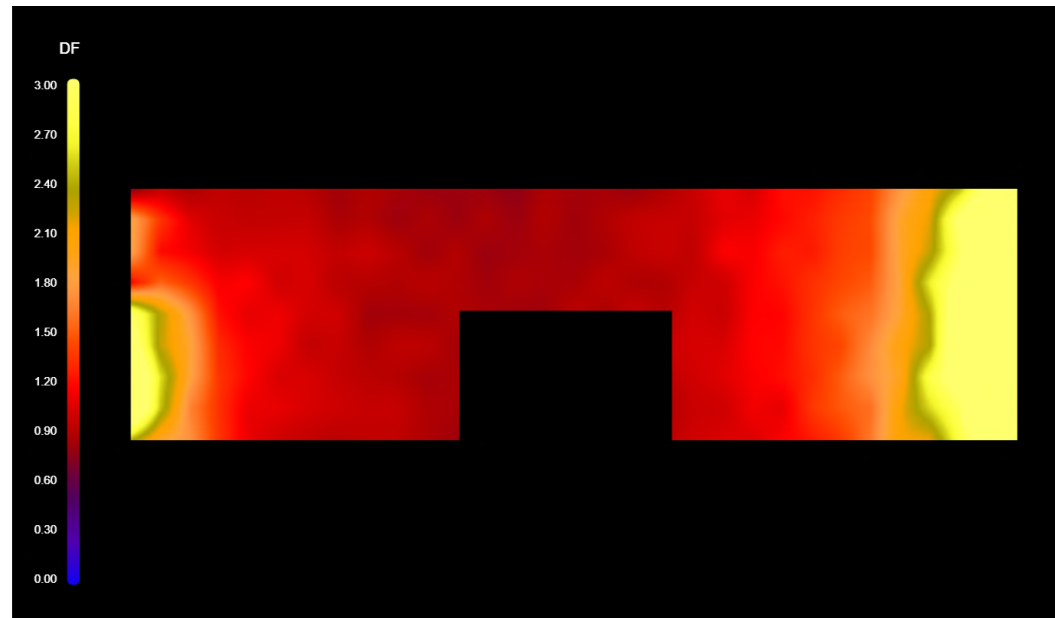

Average	D	1.58%
Median	D	1.11%
Minimum	D	0.72%
Maximum	D	6.45%
Uniformity 1	D_{min}/D_{avg}	0.4556
Uniformity 2	D_{min}/D_{max}	0.1114

EN17037

$F_{plane, \%} \geq 0.8\%$	D_{TM}	99%	Pass ($\geq 95\%$)
$F_{plane, \%} \geq 2.5\%$	D_T	14%	Fail ($< 50\%$)
$F_{plane, \%} \geq 4.1\%$	D_T	6%	Fail ($< 50\%$)
$F_{plane, \%} \geq 6.2\%$	D_T	0%	Fail ($< 50\%$)

w_zone 02 A



Average	D	2.04%
Median	D	1.40%
Minimum	D	0.86%
Maximum	D	8.00%
Uniformity 1	D_{min}/D_{avg}	0.4195
Uniformity 2	D_{min}/D_{max}	0.1072

EN17037

$F_{plane, \%} \geq 0.8\%$	D_{TM}	100%	Pass ($\geq 95\%$)
$F_{plane, \%} \geq 2.5\%$	D_T	25%	Fail ($< 50\%$)
$F_{plane, \%} \geq 4.1\%$	D_T	11%	Fail ($< 50\%$)
$F_{plane, \%} \geq 6.2\%$	D_T	3%	Fail ($< 50\%$)

w_zone 02 B



Average	D	2.07%
Median	D	1.45%
Minimum	D	0.87%
Maximum	D	8.22%
Uniformity 1	D_{min}/D_{avg}	0.4225
Uniformity 2	D_{min}/D_{max}	0.1063

EN17037

$F_{plane, \%} \geq 0.8\% D_{TM}$	100%	Pass ($\geq 95\%$)
$F_{plane, \%} \geq 2.5\% D_T$	25%	Fail ($< 50\%$)
$F_{plane, \%} \geq 4.1\% D_T$	10%	Fail ($< 50\%$)
$F_{plane, \%} \geq 6.2\% D_T$	2%	Fail ($< 50\%$)

w_zone 02 D

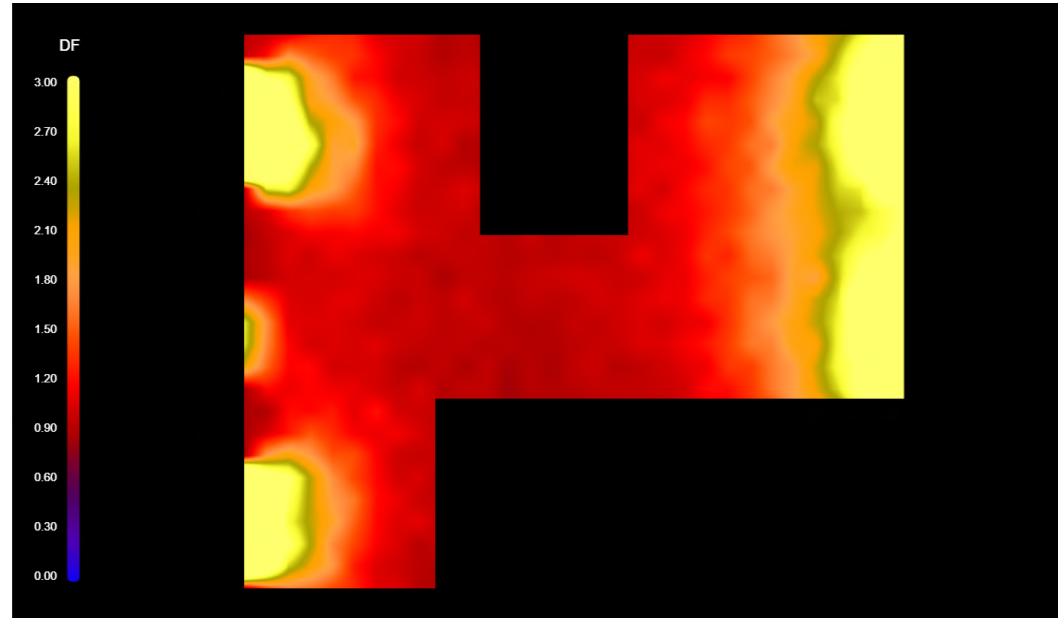

Average	D	1.75%
Median	D	1.20%
Minimum	D	0.83%
Maximum	D	7.28%
Uniformity 1	D_{min}/D_{avg}	0.4733
Uniformity 2	D_{min}/D_{max}	0.1135

EN17037

$F_{plane, \%} \geq 0.8\% D_{TM}$	100%	Pass ($\geq 95\%$)
$F_{plane, \%} \geq 2.5\% D_T$	18%	Fail ($< 50\%$)
$F_{plane, \%} \geq 4.1\% D_T$	7%	Fail ($< 50\%$)
$F_{plane, \%} \geq 6.2\% D_T$	1%	Fail ($< 50\%$)

APARTMENTS ON 4TH FLOOR

Daylight Visualizer

Calculation on zones

Project name: untitled
 Simulation type: Daylight Factor
 Daylight Visualizer version: 3.1

Select Country

Sweden

Select Report Options

- EN17037
- Active House
- Fractions of Work Planes
- Percentiles

EN17037 For Sweden the target daylight factors (D_T) are 2.5% (300 lux), 4.1% (500 lux) and 6.2% (750 lux). The minimum daylight factor target (D_{TM}) is 0.8% (100 lux). The standard is available for purchase from the National Standardization Body in your country.

w_zone 04 A



Average	D	3.61%
Median	D	2.89%
Minimum	D	1.64%
Maximum	D	12.09%
Uniformity 1	D_{min}/D_{avg}	0.4538
Uniformity 2	D_{min}/D_{max}	0.1355

EN17037

$F_{plane, \%} \geq 0.8\% D_{TM}$	100%	Pass ($\geq 95\%$)
$F_{plane, \%} \geq 2.5\% D_T$	79%	Pass ($\geq 50\%$)
$F_{plane, \%} \geq 4.1\% D_T$	22%	Fail ($< 50\%$)
$F_{plane, \%} \geq 6.2\% D_T$	9%	Fail ($< 50\%$)

w_zone 04 B



Average	D	4.16%
Median	D	3.42%
Minimum	D	1.57%
Maximum	D	11.66%
Uniformity 1	D_{min}/D_{avg}	0.3776
Uniformity 2	D_{min}/D_{max}	0.1347

EN17037

$F_{plane, \%} \geq 0.8\%$	D_{TM}	100%	Pass ($\geq 95\%$)
$F_{plane, \%} \geq 2.5\%$	D_T	86%	Pass ($\geq 50\%$)
$F_{plane, \%} \geq 4.1\%$	D_T	38%	Fail ($< 50\%$)
$F_{plane, \%} \geq 6.2\%$	D_T	15%	Fail ($< 50\%$)

CAALA

3D-MODEL FOR CAALA LCA

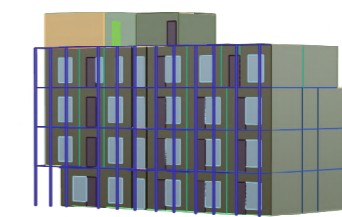
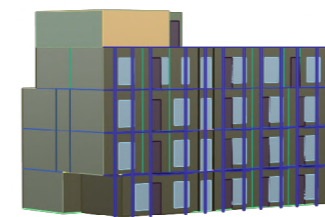
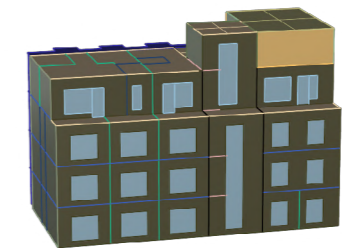
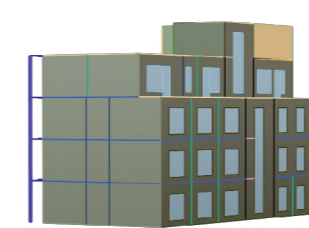
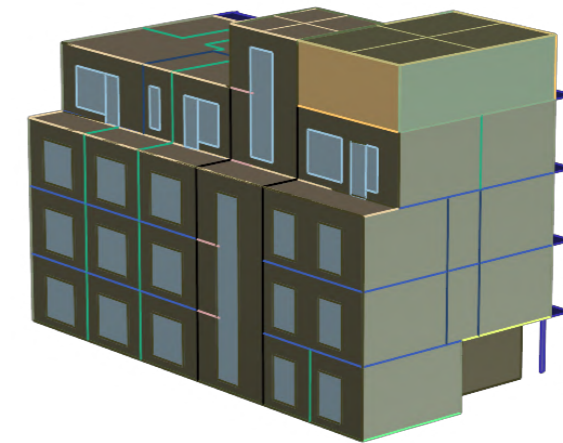

CAALA LCA

SUMMARY OF CLIMATE IMPACT REPORT, COMPARISON B

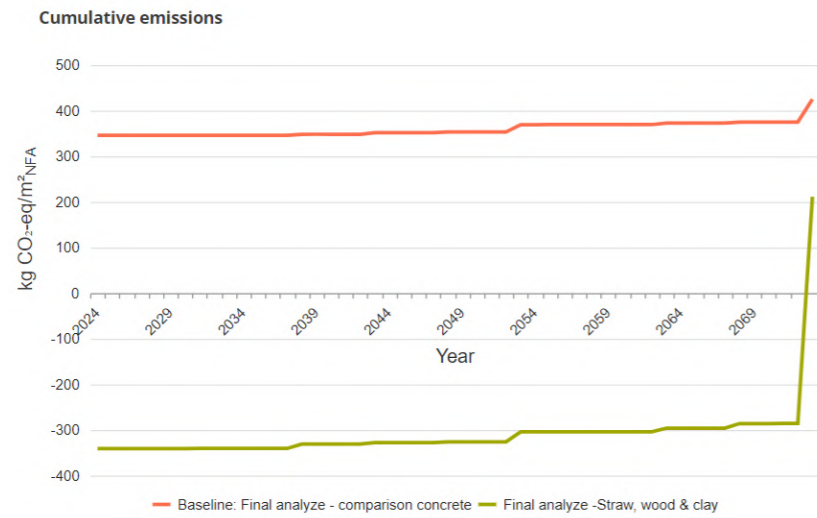

		BASELINE MODEL	FINAL ANALYZE -STRAW, WOOD & CLAY
Variant Name		Final analyze - comparison concrete	Final analyze -Straw, wood & clay
Variant Information			
NFA	[m ²]	707.85	707.85 ~ No Change
GFA	[m ²]	884.81	884.81 ~ No Change
Energy reference area	[m ²]	771.55	771.55 ~ No Change
Volume	[m ³]	2831.39	2831.39 ~ No Change
Energy parameters			
Primary energy demand	[kWh/(m ² _{AN} *a)]	65.64	53.77 18.08%
End energy demand (Heating + Aux Electricity)	[kWh/(m ² _{AN} *a)]	129.61	106.25 18.02%
Space heating	[kWh/(m ² _{AN} *a)]	68.95	51.09 25.9%
Hot water	[kWh/(m ² _{AN} *a)]	8.50	8.50 ~ No Change
Transmission heat losses H _t ¹	[W/(m ² *K)]	0.38	0.26 31.58%

Life cycle assessment			
Primary energy non renewable (PENRT)	[kWh/(m ² _{NGF} *a)]	20.80	-3.48 116.73%
Global warming potential (GWP)	[kg CO ₂ -Äqv/(m ² _{NGF} *a)]	7.31	-0.42 105.75%
Primary energy renewable total (PERT)	[kWh/(m ² _{NGF} *a)]	6.50	27.67 325.69%
Ozone depletion potential (ODP)	[kg R11-Äqv/(m ² _{NGF} *a)]	1.40e-9	2.57e-8 1735.71%
Photochemical ozone creation potential (POCP)	[kg Ethen-Äqv/(m ² _{NGF} *a)]	2.22e-3	9.78e-4 55.95%
Acidification potential (AP)	[kg SO ₂ -Äqv/(m ² _{NGF} *a)]	0.01	6.41e-3 35.9%
Eutrophication potential (EP)	[kg PO ₄ -Äqv/(m ² _{NGF} *a)]	2.33e-3	2.23e-3 4.29%
A1-A3 Production (PENRT)	[kWh/(m ² _{NGF} *a)]	21.79	11.75 46.08%
B4 Replacement (PENRT)	[kWh/(m ² _{NGF} *a)]	2.78	3.01 8.27%
B6 Energy demand in use phase (PENRT)	[kWh/(m ² _{NGF} *a)]	0.00	0.00 ~ No Change
C3+C4 End-of-life (PENRT)	[kWh/(m ² _{NGF} *a)]	0.71	0.38 46.48%
D1 Greenhouse gas potential recycling (PENRT)	[kWh/(m ² _{NGF} *a)]	-4.47	-18.62 316.55%
D2 Greenhouse gas potential recycling (PENRT)	[kWh/(m ² _{NGF} *a)]	0.00	0.00 ~ No Change
A1-A3 Production (GWP)	[kg CO ₂ -Äqv/(m ² _{NGF} *a)]	6.92	-6.81 198.41%
B4 Replacement (GWP)	[kg CO ₂ -Äqv/(m ² _{NGF} *a)]	0.58	1.10 89.66%
B6 Energy demand in use phase (GWP)	[kg CO ₂ -Äqv/(m ² _{NGF} *a)]	0.00	0.00 ~ No Change
C3+C4 End-of-life (GWP)	[kg CO ₂ -Äqv/(m ² _{NGF} *a)]	1.01	9.94 884.16%
D1 Greenhouse gas potential recycling (GWP)	[kg CO ₂ -Äqv/(m ² _{NGF} *a)]	-1.20	-4.64 286.67%
D2 Greenhouse gas potential recycling (GWP)	[kg CO ₂ -Äqv/(m ² _{NGF} *a)]	0.00	0.00 ~ No Change
Life cycle costs			
Total life cycle costs	[€/m ² _{BGF}]	0.00	0.00 ~ No Change

CAALA LCA

SUMMARY OF CLIMATE IMPACT REPORT, COMPARISON C

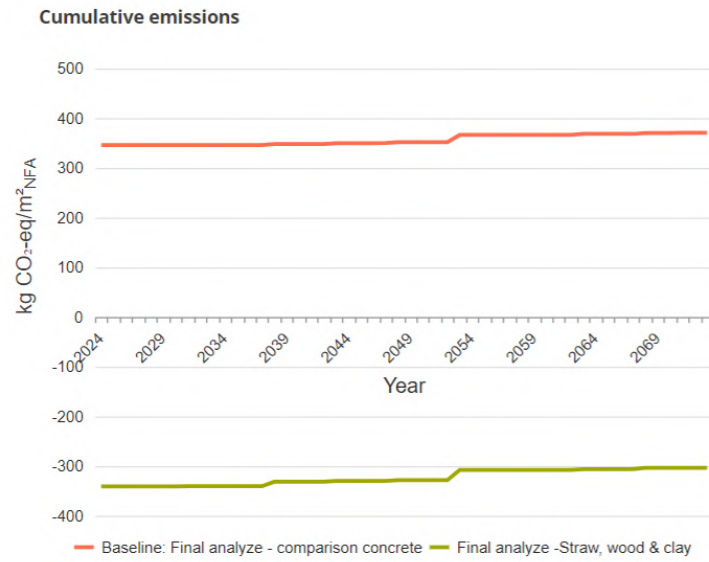

	BASELINE MODEL		FINAL ANALYZE -STRAW, WOOD & CLAY	
Variant Name	Final analyze - comparison concrete		Final analyze -Straw, wood & clay	
Variant Information				
NFA	[m ²]	707.85	707.85	~ No Change
GFA	[m ²]	884.81	884.81	~ No Change
Energy reference area	[m ²]	849.42	849.42	~ No Change
Volume	[m ³]	2654.43	2654.43	~ No Change
Energy parameters				
Primary energy demand	[kWh/(m ² _{AN} *a)]	59.54	48.80	18.04%
End energy demand (Heating + Aux Electricity)	[kWh/(m ² _{AN} *a)]	117.58	96.44	17.98%
Space heating	[kWh/(m ² _{AN} *a)]	60.01	43.85	26.93%
Hot water	[kWh/(m ² _{AN} *a)]	8.50	8.50	~ No Change
Transmission heat losses H _t '	[W/(m ² *K)]	0.38	0.26	31.58%

Life cycle assessment				
Primary energy non renewable (PENRT)	[kWh/(m ² _{NGF} *a)]	20.06	-4.00	119.94%
Global warming potential (GWP)	[kg CO ₂ -Äqv/(m ² _{NGF} *a)]	6.21	-10.71	272.46%
Primary energy renewable total (PERT)	[kWh/(m ² _{NGF} *a)]	7.86	52.32	565.65%
Ozone depletion potential (ODP)	[kg R11-Äqv/(m ² _{NGF} *a)]	1.40e-9	2.50e-8	1685.71%
Photochemical ozone creation potential (POCP)	[kg Ethen-Äqv/(m ² _{NGF} *a)]	2.17e-3	8.82e-4	59.35%
Acidification potential (AP)	[kg SO ₂ -Äqv/(m ² _{NGF} *a)]	0.01	5.43e-3	45.7%
Eutrophication potential (EP)	[kg PO ₄ -Äqv/(m ² _{NGF} *a)]	2.21e-3	1.90e-3	14.03%
A1-A3 Production (PENRT)	[kWh/(m ² _{NGF} *a)]	21.79	11.75	46.08%
B4 Replacement (PENRT)	[kWh/(m ² _{NGF} *a)]	2.74	2.87	4.74%
B6 Energy demand in use phase (PENRT)	[kWh/(m ² _{NGF} *a)]	0.00	0.00	~ No Change
C3+C4 End-of-life (PENRT)	[kWh/(m ² _{NGF} *a)]	0.00	0.00	~ No Change
D1 Greenhouse gas potential recycling (PENRT)	[kWh/(m ² _{NGF} *a)]	-4.47	-18.62	316.55%
D2 Greenhouse gas potential recycling (PENRT)	[kWh/(m ² _{NGF} *a)]	0.00	0.00	~ No Change
A1-A3 Production (GWP)	[kg CO ₂ -Äqv/(m ² _{NGF} *a)]	6.92	-6.81	198.41%
B4 Replacement (GWP)	[kg CO ₂ -Äqv/(m ² _{NGF} *a)]	0.49	0.74	51.02%
B6 Energy demand in use phase (GWP)	[kg CO ₂ -Äqv/(m ² _{NGF} *a)]	0.00	0.00	~ No Change
C3+C4 End-of-life (GWP)	[kg CO ₂ -Äqv/(m ² _{NGF} *a)]	0.00	0.00	~ No Change
D1 Greenhouse gas potential recycling (GWP)	[kg CO ₂ -Äqv/(m ² _{NGF} *a)]	-1.20	-4.64	286.67%
D2 Greenhouse gas potential recycling (GWP)	[kg CO ₂ -Äqv/(m ² _{NGF} *a)]	0.00	0.00	~ No Change
Life cycle costs				
Total life cycle costs	[€/m ² _{BGF}]	0.00	0.00	~ No Change

CAALA LCA

EXTENDED SUMMARY OF CLIMATE IMPACT REPORT, COMPARISON A
 (For access to full report -contact author)

Caala Bericht erstellt am 29.4.2024 um 12:17:46



Caala Report

For Project: The Straw Project - Final Analyze

Variant Name: Final analyze -Straw, wood & clay



Caala Bericht erstellt am 29.4.2024 um 12:17:46



1. Object data

1.1. Object

Model	Final design_adjusted elevator_metres(lastest)
Scope of analysis	Full Life Cycle
Level of detail	Blueprint planning
Building type	Apartment building
Energy standard	GEG
Reference study period	50 Jahre
Climate region - reference location	Region 10 - Hof
Database	Oekobaudat version 2020

1.2. Geometry

Number of floors	4
Average floor height	3.20 m
V	3117.12 m ³
GFA th.	974.10 m ²
NFA	779.28 m ²
Reference area	849.42 m ²

2. Overview

2.1. Primary energy demand

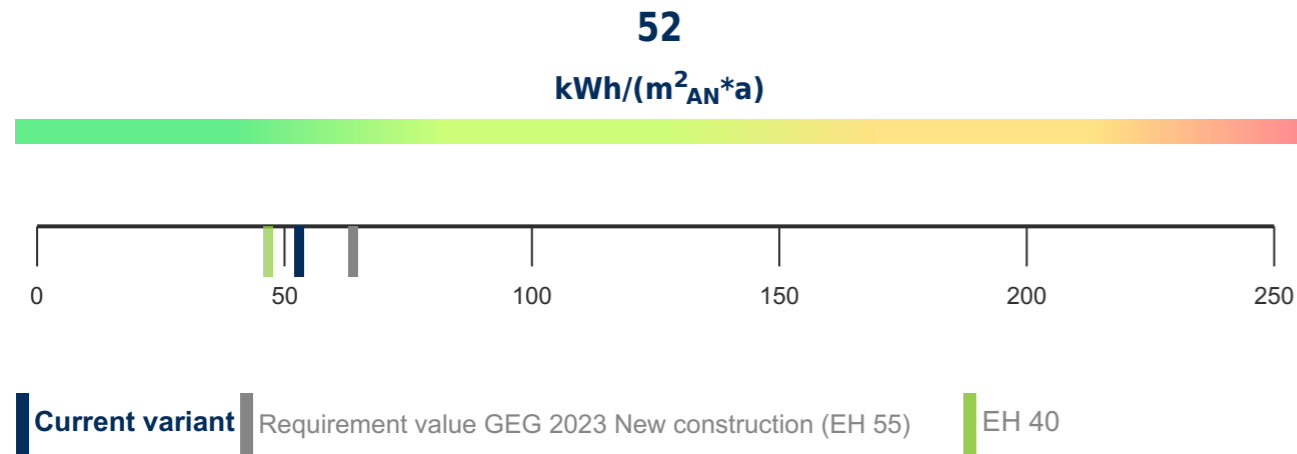

2.2. Life Cycle Assessment

Primary energy non renewable (PENRT)

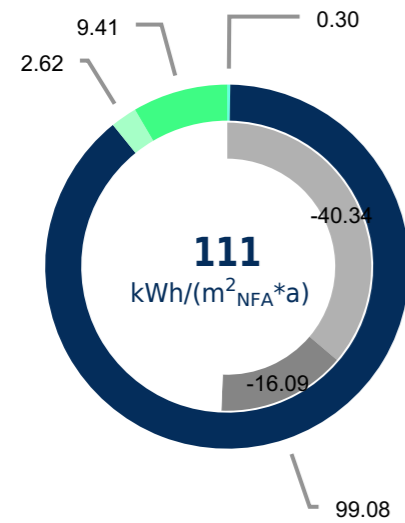

Global warming potential (GWP)

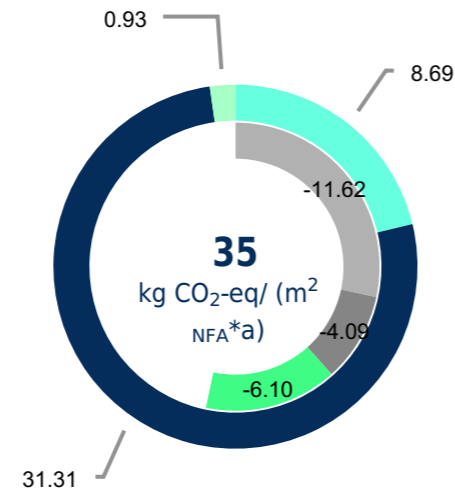

- A1-A3 Production
- B4 Replacement
- B6 Energy demand in use phase
- C3+C4 End-of-life
- D1 Benefits from recovery outside the system boundaries
- D2 Benefits from exported energy

Life cycle costs

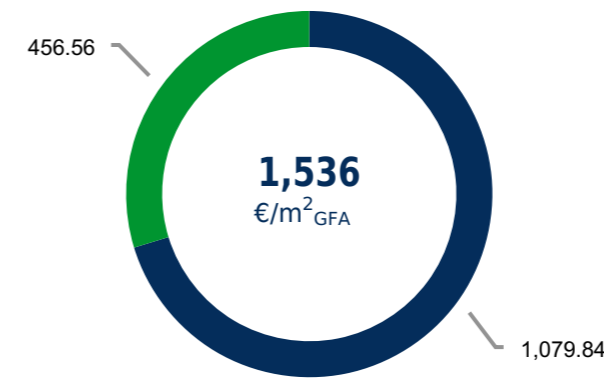

Mass Balance

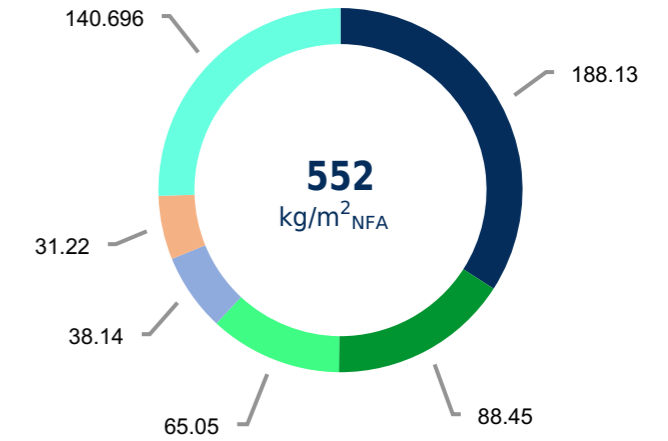

- Investment costs
- Energy costs
- Maintenance & Replacement
- Repair
- CO₂ Cost

- CAALA_B01 Ceiling
- CAALA_A10 Floor to unheated space
- CAALA_A01 Exterior wall load-bearing
- CAALA_A05 Wall to unheated roof
- CAALA_B03 Interior wall non-load-bearing
- Others

3. Mass Balance

3.1. Masses per material

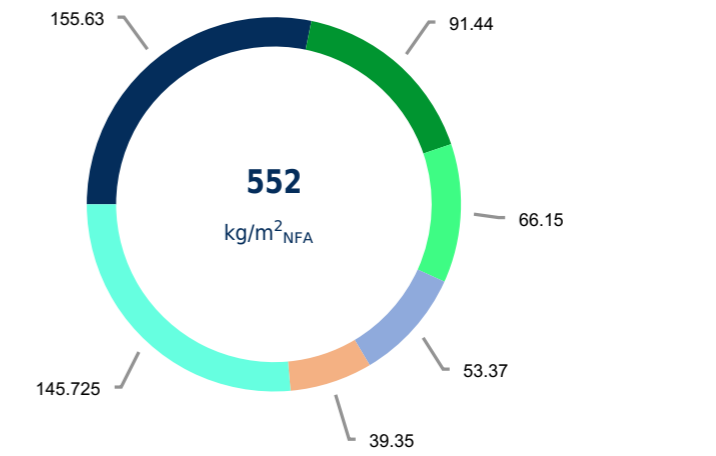

- Gravel 2/32 dried
- Konstruktionsvollholz (Durchschnitt DE)
- Lime plaster
- Clay plaster
- FASBA e.V. Baustroh
- Others

4. Life cycle assessment

4.1. Boundary conditions

Assessment period	50 Jahre
Net floor area (NFA)	779.28 m ²
Database	Oekobaudat version 2020
Assessed life cycle modules	A1-A3, B4, B6, C3+C4, D1, D2

4.2. Overview of the results

	MODULE	GWP	ODP	POCP	AP	EP	PENRT	PERT
Embodied	A1-A3, B4, C3+C4, D1	-0.58	1,782e-8	7,968e-4	5,408e-3	1,917e-3	-3.75	23.99
Operational	B6	31.31	2,737e-14	3,094e-3	3,215e-2	5,939e-3	99.08	17.78
Total		30.73	1,782e-8	3,891e-3	3,756e-2	7,856e-3	95.33	41.77

7.3. Building Technology

420 Heat generation equipment	District heating CHP
Primary energy factor electricity	1.8
Investment costs KG	0.00 €
Investment cost for ventilation system	0.00 €
Performance coefficient _p	0.91
440 Photovoltaik	
Investment costs	0 €
Celltype	Monocrystalline silicon manufactured after 2017
Ventilation type	Highly ventilated or freestanding modules
Photovoltaik 1	
Orientation	South-west
Inclination	30°
Area	150 m ²
460 Conveyor systems	Not available

7.4. Other input values and boundary conditions

Thermal bridge	Optimized (Category B) 0,03 W/m ² K
Air tightness	With verification: n50 = 2 h ⁻¹

4.3. Results for integrated environmental impacts

Global warming potential (GWP)

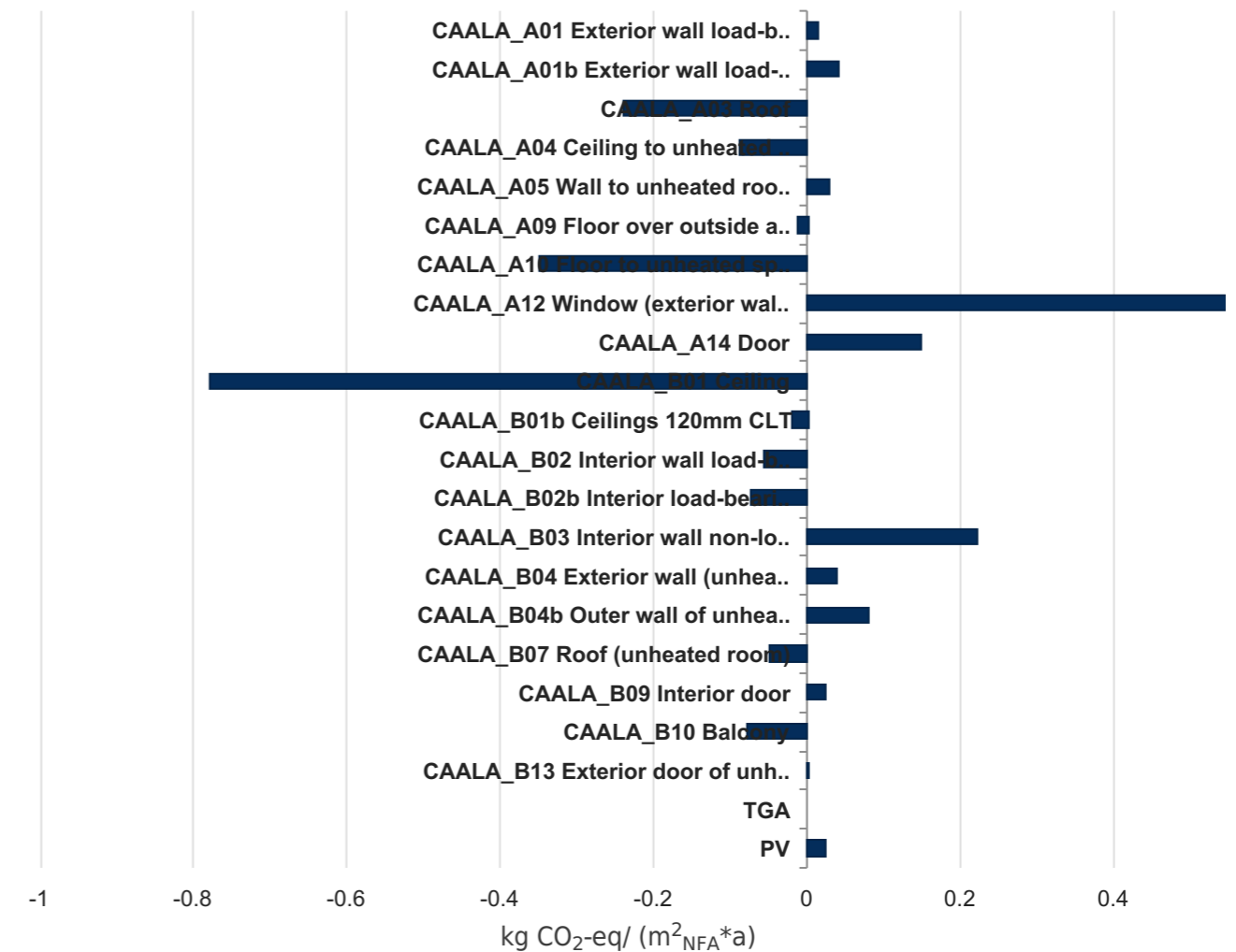

Primary energy non renewable (PENRT)

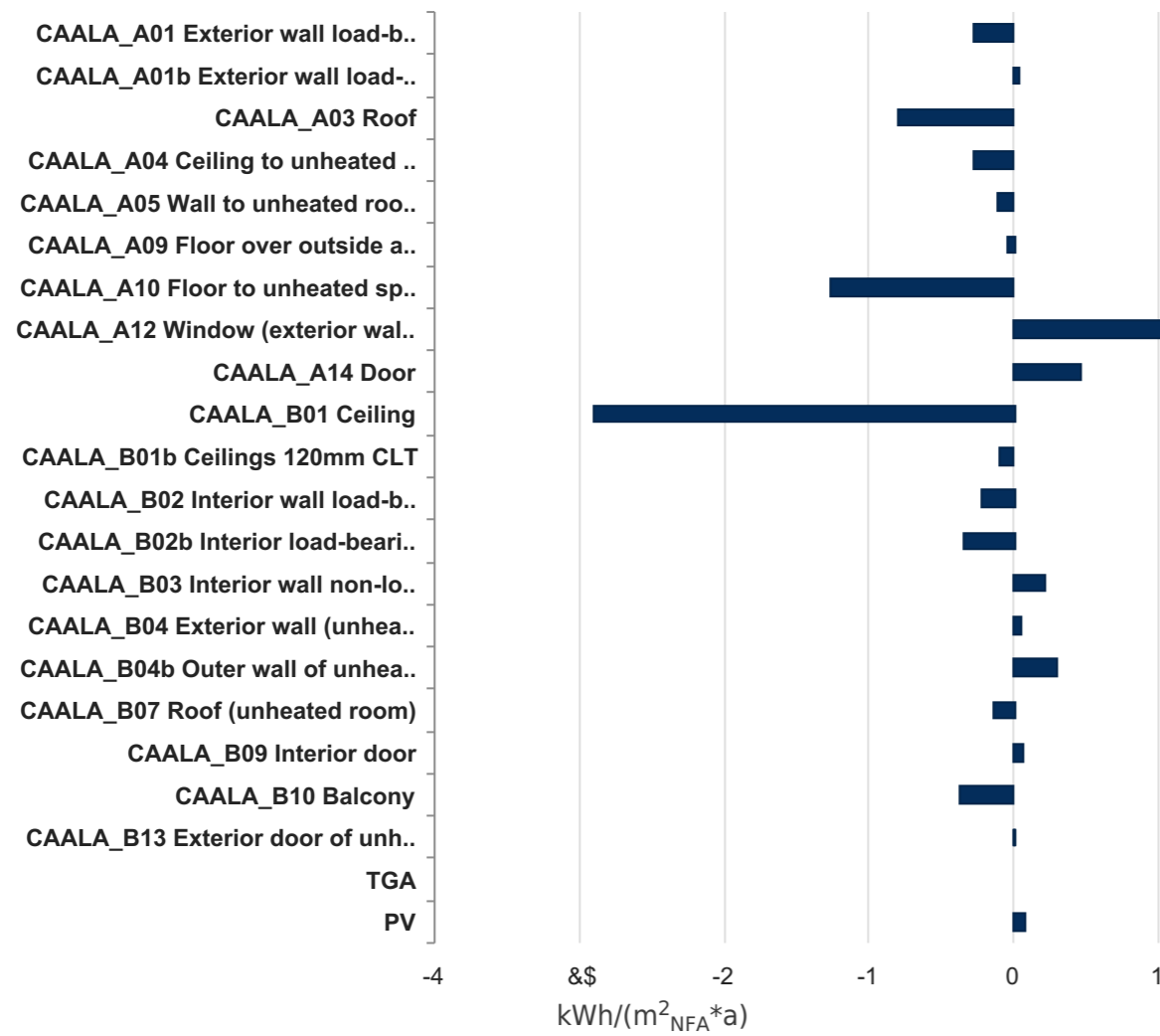

5. Cumulative emissions & costs

5.1. Cumulative emissions

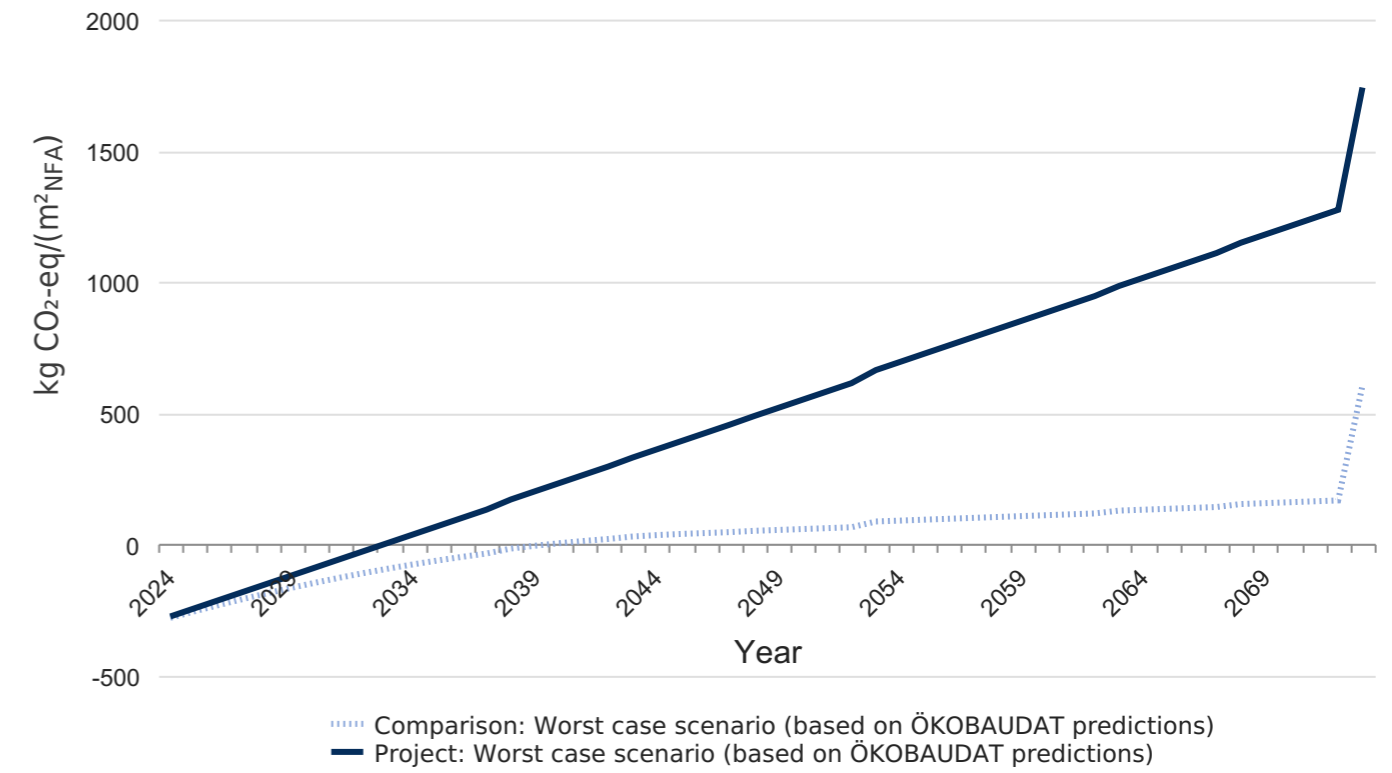

5.2. Cumulative costs

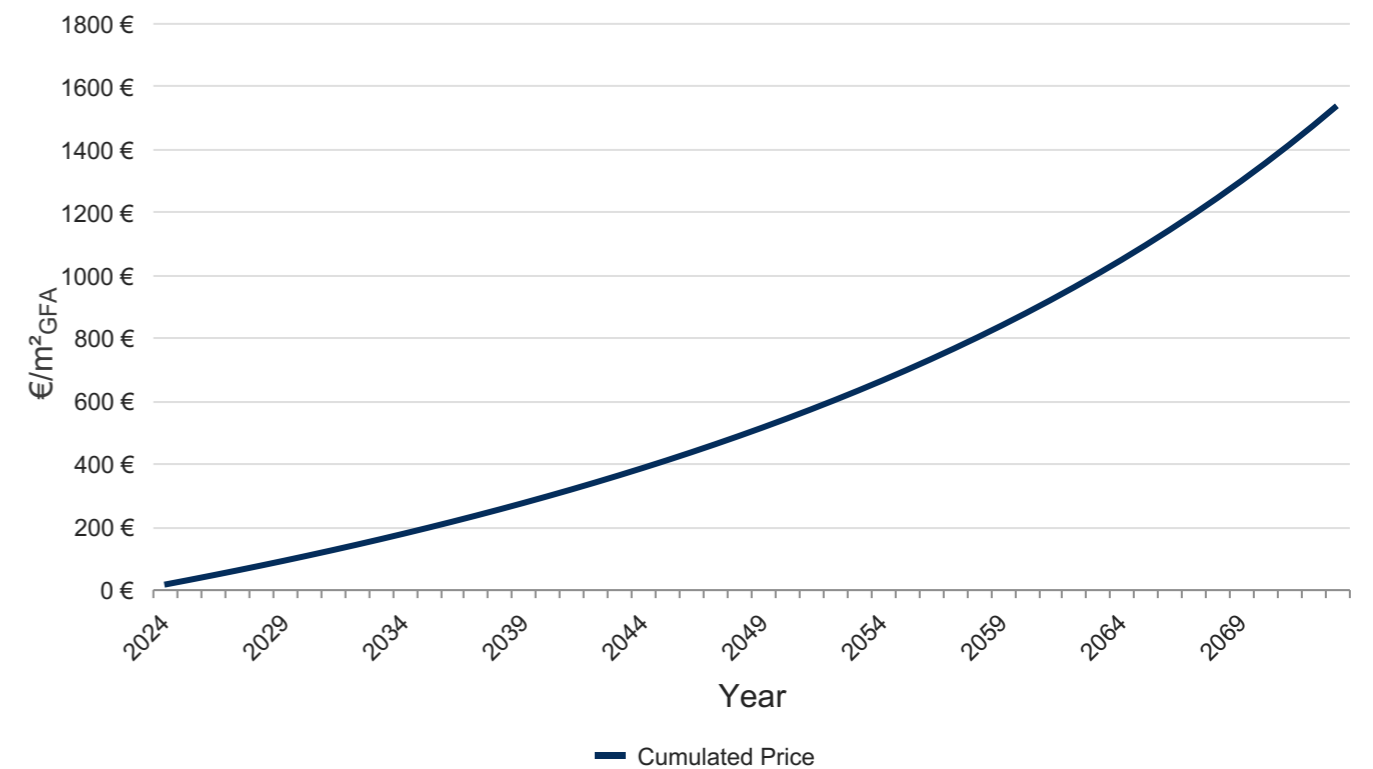

5.3. Decarbonization Pathway

Decarbonization Pathway according to CRREM methodology

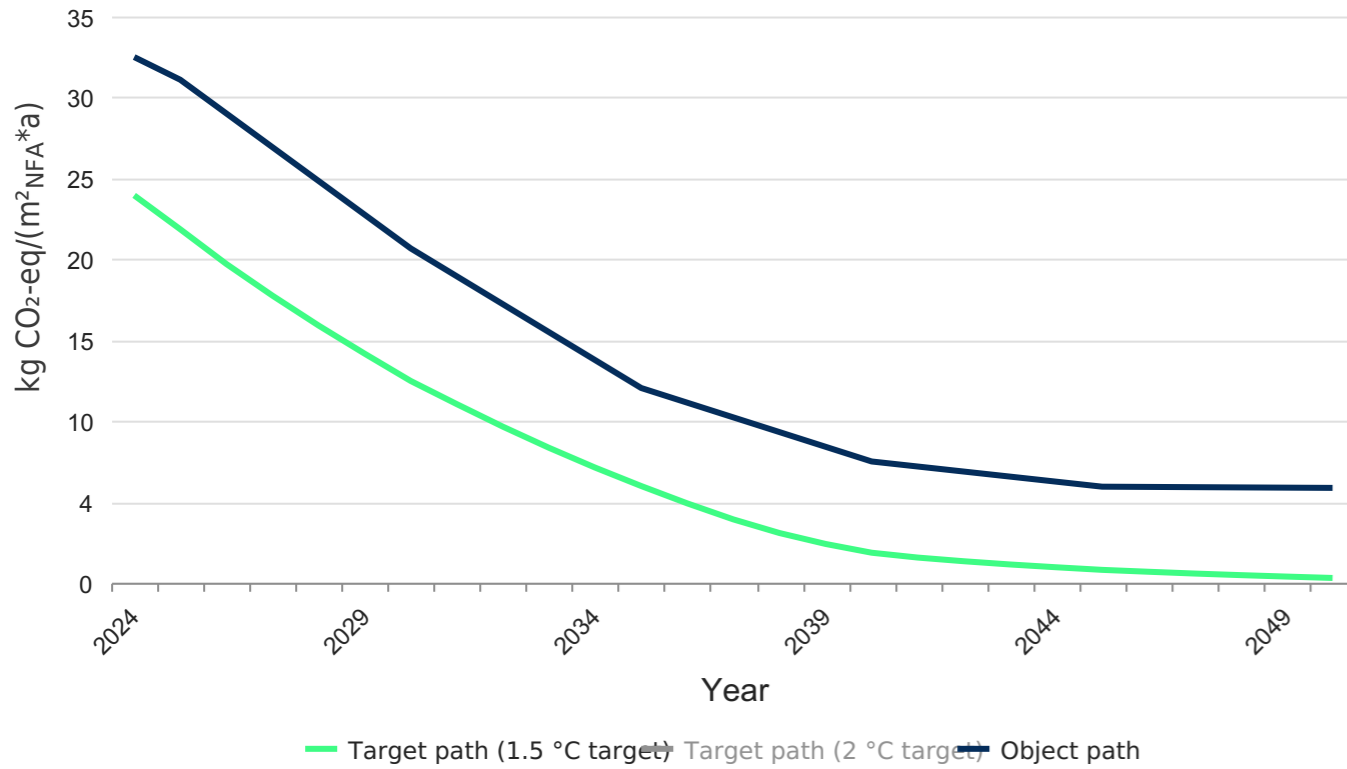

Energy Efficiency Pathway according to CRREM methodology

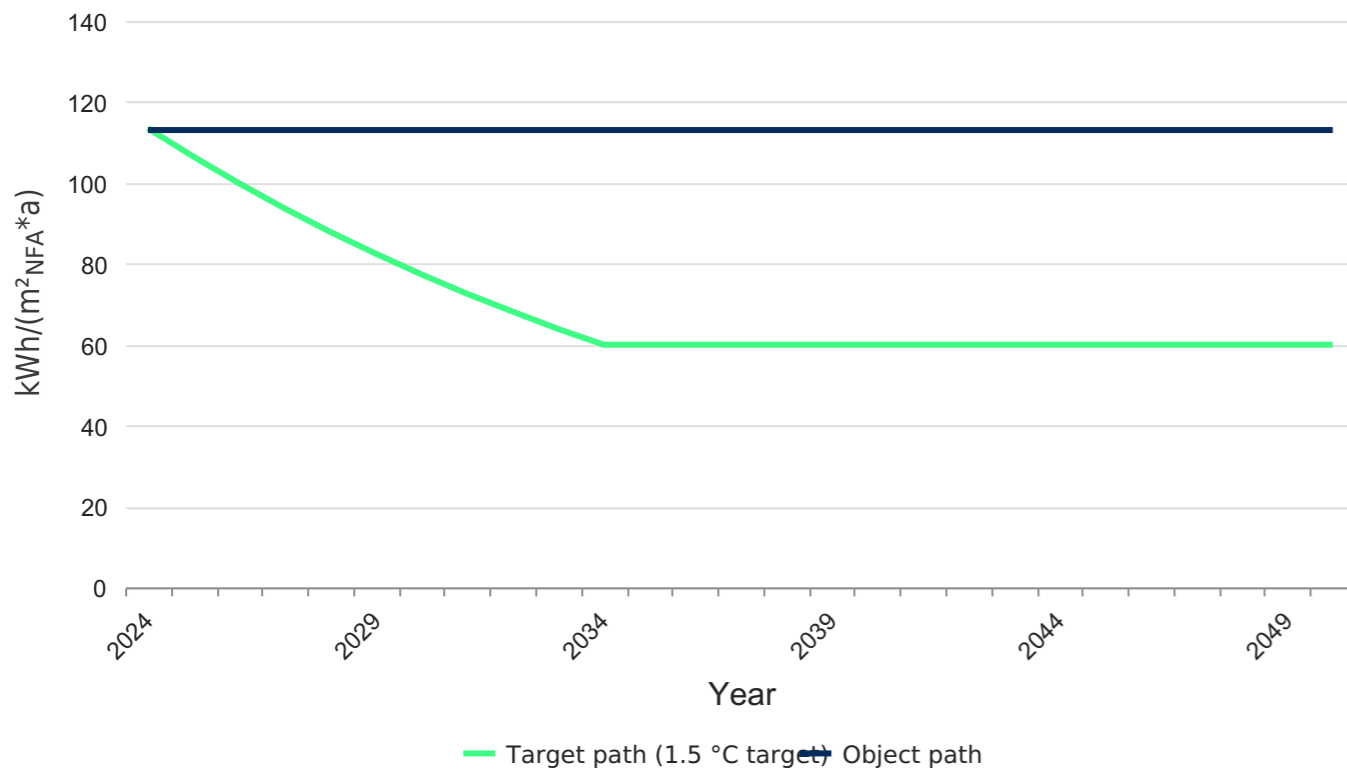

Decarbonization Pathway according to LCA methodology

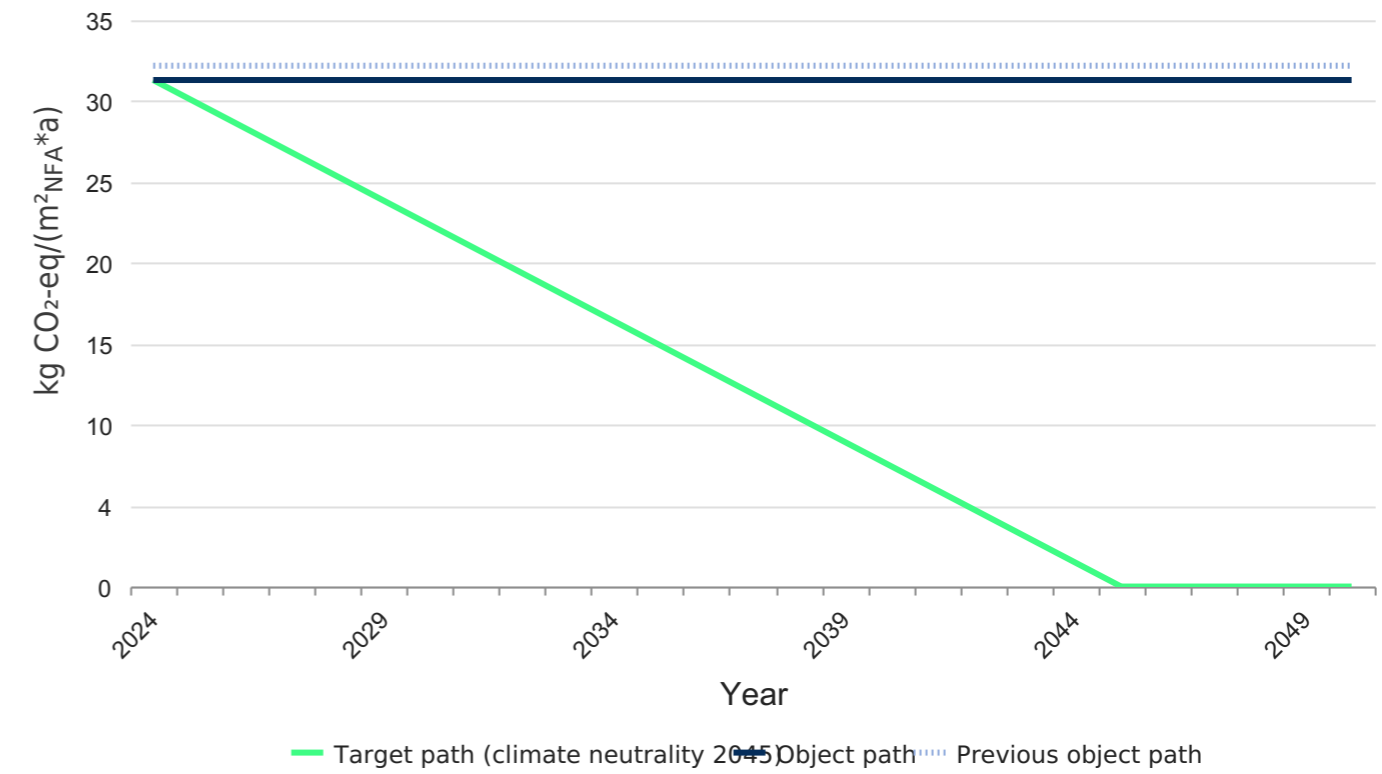



CHALMERS
UNIVERSITY OF TECHNOLOGY

THE STRAW PROJECT

Jessica Börjesson

Master Thesis 2024

Examiner: Paula Femenias

Supervisor: Walter Unterrainer

Chalmers School of Architecture
Department of Architecture and Civil Engineering
Architecture and Planning Beyond Sustainability