

VITREUM

GLASSWORK AND EXHIBITION CENTER



Sophia Andersson

Chalmers University of Technology
Department of Architecture and Civil Engineering

Examiner: Mikael Ekegren
Supervisor: Björn Gross

VITREUM
GLASSWORK AND EXHIBITION CENTER



CHALMERS
UNIVERSITY OF TECHNOLOGY

Sophia Andersson

Chalmers University of Technology
Department of Architecture and Civil Engineering
Master's Programme of Architecture and Urban Design (MPARC)
Graduation and publication year: 2023

Examiner: Mikael Ekegren
Supervisor: Björn Gross

All drawings and images are copyrighted by the author unless otherwise stated.

ABSTRACT

What makes a place, and what contributes to its identity? Gothenburg has a long history as a port city, with industries along Göta älv. However, in recent years these places are no longer used in the same way, which has contributed to empty premises and run-down areas. But if we were to remove these buildings, the city would have a different character and identity. By observing the existing character that gives Ringön its identity, a new building can emerge with inspiration from the history of the site. In this way, the area's unique character can be preserved, and at the same time, developed and enriched with new architecture.

Ringön is a centrally located place, but still on the edge of the inner city of Gothenburg. During the latter part of the 19th century, the land was bought up by the city of Gothenburg, where they began to build the harbor facility Ringön. In 1939, the Göta älv bridge was built, a new town plan was established, and the area was transformed into an industrial area.

Today, everything from music to concrete is produced on Ringön, and there is a sense of settler spirit that permeates the area. After a site analysis and a review of the development project *Saltet*, the idea of a glasswork with an associated exhibition center arose. Letting the old meet the new is the keyword, where traditional craftsmanship and artistry are combined with new design ideas. Through analyzing theoretical and built references, the thesis aims to investigate Ringön's identity and develop a modern glasswork with an associated exhibition center, with inspiration from the area's industrial character. Additionally, explore how the movement and flow of a glasswork can be designed, as well as to investigate the architectural experience of an exhibition hall. The design proposal aims to answer, *How can a modern glasswork and exhibition center be constructed with inspiration from the industrial character at Ringön?*, with the sub-question, *In what way can different room compositions vary the architectural experience of an exhibition space?*

TABLE OF CONTENTS

| | |
|--|--------|
| BACKGROUND | 8-9. |
| CV | 8. |
| Aim | 9. |
| Research question | 9. |
| Methodology | 9. |
| Delimitation | 9. |
| Keywords | 9. |
| CHAPTER 1 - CONTEXT | 10-19. |
| Glasswork | 12. |
| Ringön | 14. |
| Industrial buildings | 18. |
| CHAPTER 2 - MATERIALS & GENERIC SPACE | 20-29. |
| Theoretical References | 22. |
| Built References | 24. |
| CHAPTER 3 - THE SITE | 30-37 |
| Site Analysis | 32. |
| Architectural observation | 36. |
| CHAPTER 4 - PROPOSAL | 38-69. |
| Concept | 40. |
| Proposal | 42. |
| Site | 44. |
| Section | 47. |
| Program | 48. |
| Plan and section | 50. |
| Elevations | 54. |
| Construction & detail | 60. |
| CHAPTER 5 - ANALYSIS, ARCHITECTURAL EXPERIENCE | 70-75 |
| Original floor plan | 72. |
| Enfilade | 73. |
| Visual continuum | 74. |
| Flowing space | 75. |
| DISCUSSION | 76-77. |
| REFERENCE LIST | 78-79. |

CV

2015 Social psychology, University of Gothenburg

2017-2020 Bachelor's degree, Chalmers University

2020-2021 Internship, Liljewall, Gothenburg

2021-2023 Master's program, Architecture and Urban Design
Chalmers University

Studio, fall term 2021: AUT164
Future visions for healthcare, housing and work 1: Residential
healthcare - housing for seniors

Course, fall term 2021: ARK650
Sustainable Development and the Design Professions

Course, spring term 2022: ARK079
Nordic architecture

Studio spring term 2022: ARK137
Future visions for healthcare, housing and work 2: Housing
inventions

Course, spring term 2022: ARK615
Norm-critical perspectives in architecture and urban design

Course, fall term 2022: ARK636
Masters thesis preparation Part 1

Course, fall term 2022: ARK641
Masters thesis preparation Part 2

2022 Participating junior architect, Liljewall, Gothenburg

AIM

The purpose of the master's thesis is to create a design proposal for a new glasswork with an associated exhibition center on Ringön. Ringön, located by Göta älv in Gothenburg, has a long history as an industrial area, hence the design proposal follows this spirit of production. The thesis aims to investigate Ringön's identity and develop a modern glasswork with an associated exhibition center, with inspiration from the area's industrial character. Additionally, explore how the movement and flow of a glasswork can be designed, as well as investigate the architectural experience of an exhibition hall.

RESEARCH QUESTION

How can a modern glasswork and exhibition center be constructed with inspiration from the industrial character at Ringön?

SUB-QUESTION

In what way can different room compositions vary the architectural experience of an exhibition space?

METHODOLOGY

This thesis has a research by design approach. To be able to answer the thesis questions, theoretical references that deal with flexibility, general spaces, and dramaturgy in architecture, as well as how we can interpret the built environment have been read. The theoretical references have contributed to a broader understanding of different design tools and approaches in architecture. Built references of similar typology have been analyzed to create a deeper understanding of the different building functions and design layouts. Additionally, interviews with glass artists and people who are active in the development of Ringön have been carried out, as well as a study visit at Skruf glasswork. Together with built and theoretical references, the work takes its point of departure in Ringön and its history and development. The design proposal was developed simultaneously with the analysis work.

DELIMITATION

The main focus of this project is primarily design and development of architectural qualities. The project follows to some extent the detailed plan, with a deviation regarding the building height. Furthermore, the design proposal, glasswork and exhibition center, is speculative and the economic aspect is not considered at this stage. In addition, the thesis will not deal with urban planning and how existing buildings can be affected by the design proposal. Due to the scope of the thesis, the room compositions analyzed have been limited in number, and consist of configurations of walls.

KEYWORDS

Exhibition, glasswork, historical context, identity, industrial character

CHAPTER 1
CONTEXT



Hand-blown glass

GLASSWORK

Glass is a historical material, which can be dated back to 5000 years ago. Around 1700-1600 BC glass began to be made in eastern Mesopotamia and Egypt (Ballard Bell & Rand, 2006). As early as the 5th century in Sweden, people began to melt and recycle glass to make pearls. However, it took until the 13th century before glass for windows in churches began to be manufactured (The Glassery, 2022a). The manufacture of glass in Sweden took off at the end of the 19th century, with Småland being one of the leading places in the country. Until the end of 1990, there were roughly three hundred different glassworks around the country (The Glassery, 2022b).

Glass consists of three different components, glass formers, fluxes, and stabilizers (The Glassery, 2022c). The glass former is the basic glass material, in the past quartz sand was used for glass production, but in traditional glass today silicon dioxide is used instead, which gives a greater purity. The fluxes are substances whose task is to lower the melting temperature of the glass material and give increased viscosity. The task of the stabilizers is to counteract the effect of the flux on the glass's firmness, as well as to affect the glass's shine, gloss, and how the light is refracted. What determines what types of ingredients used in the manufacture is what the glass is to be used for. Depending on the type of glass former, flux, and stabilizers used in the process, the glass and quality differ (The Glassery, 2022c). According to Kent Elm, the owner of Skruf glasswork (personal communication, January 27, 2023), it is more common to use glass pellets in the production today, instead of different glass components. The pellets are mixed into a desired combination, which contributes to a reduced need for extra storage space.

According to the glass artist Helena Gibson (personal communication, November 7, 2023), a glasswork is divided into two different workspaces, consisting of a cold, and a hot part. In the hot part of the workshop, the melting of glass takes place, where a melting furnace heats glass or glass blanks to a temperature of around 1400 degrees. The glass is then processed by a glassblower, in some cases machines, when the glass is around 1100 degrees, she says. In the cold part of the workshop, the finished glass object is then treated. In these spaces, the objects are painted, sanded, and engraved to achieve their final appearance. An important part of the cold section is the cooling oven, where the objects are cooled down slowly to minimize stress and cracking.

To create glass art, there are several different types of techniques. One technique is called Överfångsglas (Over-catch glass) and is originally an oriental art glass technique, where an uncolored glass object receives one or more layers of color which are then removed, creating a relief pattern. Another technique is called Graal and is a development of the previous technique, here, however, a colored glass object is processed into a layer of clear glass, which gives the illusion that the colored object inside is floating in the glass object. Other techniques are, among others, the milk glass technique, the net wire technique, Kraka, Ariel, and Ravenna (The Glassery, 2022d).



Workshop at skruf



Basic material - Glass pellets



Cold-Technical workshop



RINGÖN

Ringön, formerly called Tingsstadsvassen, was originally a wetland and grew through the construction of a nearly two-kilometer canal at the end of the 19th century. The canal was called Ringkanalen and went like an arc from Göta älv to Kvillebäcken, which also gave Tingsstadsvassen its new name, Ringön (Nylander, 2017). With the city of Gothenburg's new harbor facility, quays and four harbor basins were built facing the river. Dockyards were established, and a new station was built, with railway tracks that were laid to the new port. However, it was mainly next to the harbor basins that there were buildings at this time, the northern part was still undeveloped says Nylander.

Ringön is today centrally located but was formerly Gothenburg's outskirts in several ways. From an article in Göteborgs-posten (2017), Nylander says that only two connections from Hisingen went to Ringön, which contributed to the isolation of the area. Since the area was isolated from the rest of the city, the area became a place for people who sought to get away from the general public and an unregulated shantytown was developed, he says. Furthermore, in 1922 the first part of Frihamnen was ready, which contributed to a reduced need for Ringön. Ringön never achieved any great success as a harbor area. One of the reasons was that new larger boats required deeper harbors, says Nylander. When the Göta älv bridge was built in 1939, the western part of Ringkanalen was closed again. A new town plan was established, where Ringön was to be transformed into an industrial area. In the coming decades, Ringkanalen was filled in again and the shantytown was demolished (Nylander, 2017).

Although Ringön is no longer an island, its name has been retained. Today, Ringön is part of the urban development in the city of Gothenburg, where the project *Saltet* is one of Gothenburg's jubilee initiatives and part of the 400th-anniversary celebrations. The starting point with the project was the conviction to set Gothenburg in motion with the help of Ringön, where Ringön can become a living place that allows for a variety of activities, old and new ones (Business Region Göteborg, 2022). A discussion was held at the beginning of the project that would contribute to ideas about culture. The discussion led to questions about why the city of Gothenburg has such difficulty in seeing the value between subculture and establishment, even though these are important factors for a city to be experienced as alive, contemporary, and exciting. The discussions resulted in the pilot project *Tillåtande Oaser*, which had the intention of preserving and strengthening the identity of Ringön. One of the reasons why this project ended up on Ringön was above all the many empty premises that could be found in the area, with low rents. In addition, today there are no residents in the area to consider, which makes it possible for several different activities, which would otherwise not be able to fit in a city (Business Region Göteborg, 2022).

The result of the project *Saltet* ended up in a checklist with three points (Business Region Göteborg, 2022 p.49) (translated from Swedish):

1. Do not demolish anything on Ringön.
2. Support the businesses that already exist on the island.
3. Add new creative activities to vacant spaces."

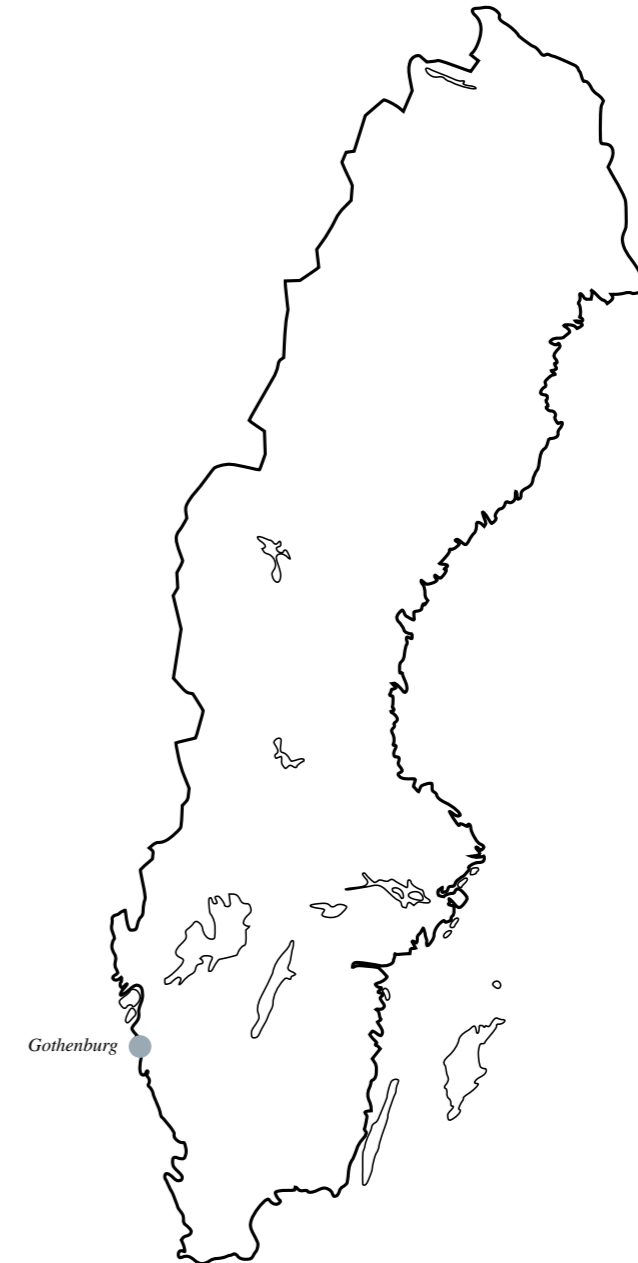



RINGÖN, SCALE 1 : 10 000

INDUSTRIAL BUILDINGS

According to *Skatteverkets allmänna råd* (SKV A 2021:24), an industrial building is defined as a building that is set up for industrial activity, where industrial activity refers to the manufacture of goods, which are produced with mechanical aids. Today, there are several different types of industrial buildings, ranging from truss buildings to insulated tent structures. The sizes vary and are usually based on its purpose. Depending on the purpose, as well as how long the building is expected to stand on the site, different building concepts are used (Hallgruppen, n.d.).

The materials used for industrial buildings today are many. If you search for “industrial buildings and materials”, there are several different companies that specialize in different types of materials and building concepts. According to *the Swedish Institute of Steel Construction, SBI* (2023), the most common type of steel building today are industrial buildings. What characterizes an industrial building is above all its large span. An industrial building made of steel can look many ways, where the steel frame is usually adapted to the function the building is to accommodate. The basic principle of the building system is steel beams, steel roof trusses, and steel columns. Usually, the roof truss spans the entire width of the building. However, there are examples where the building is divided into several naves, with rows of columns in between (SBI, 2023). An example of a common industrial building today is the traverse building. This building can be characterized by its simplicity and is assembled through modules. The advantage of the traverse building is that it can be constructed in several ways, where the width can vary between 18 to 30 meters, and the length between 24 to 78 meters (Northpower, 2023). Furthermore, the outer wall can be built up in different ways, usually some kind of sandwich element made of sheet metal is used, with intermediate insulation. Alternatively, the outer wall can be built with a framed construction, with profiled sheet or sheet cassette as a facade material. The roofs are often covered with sheet metal and are usually supported by a profiled sheet that is screwed directly onto the roof beam (SBI, 2023).

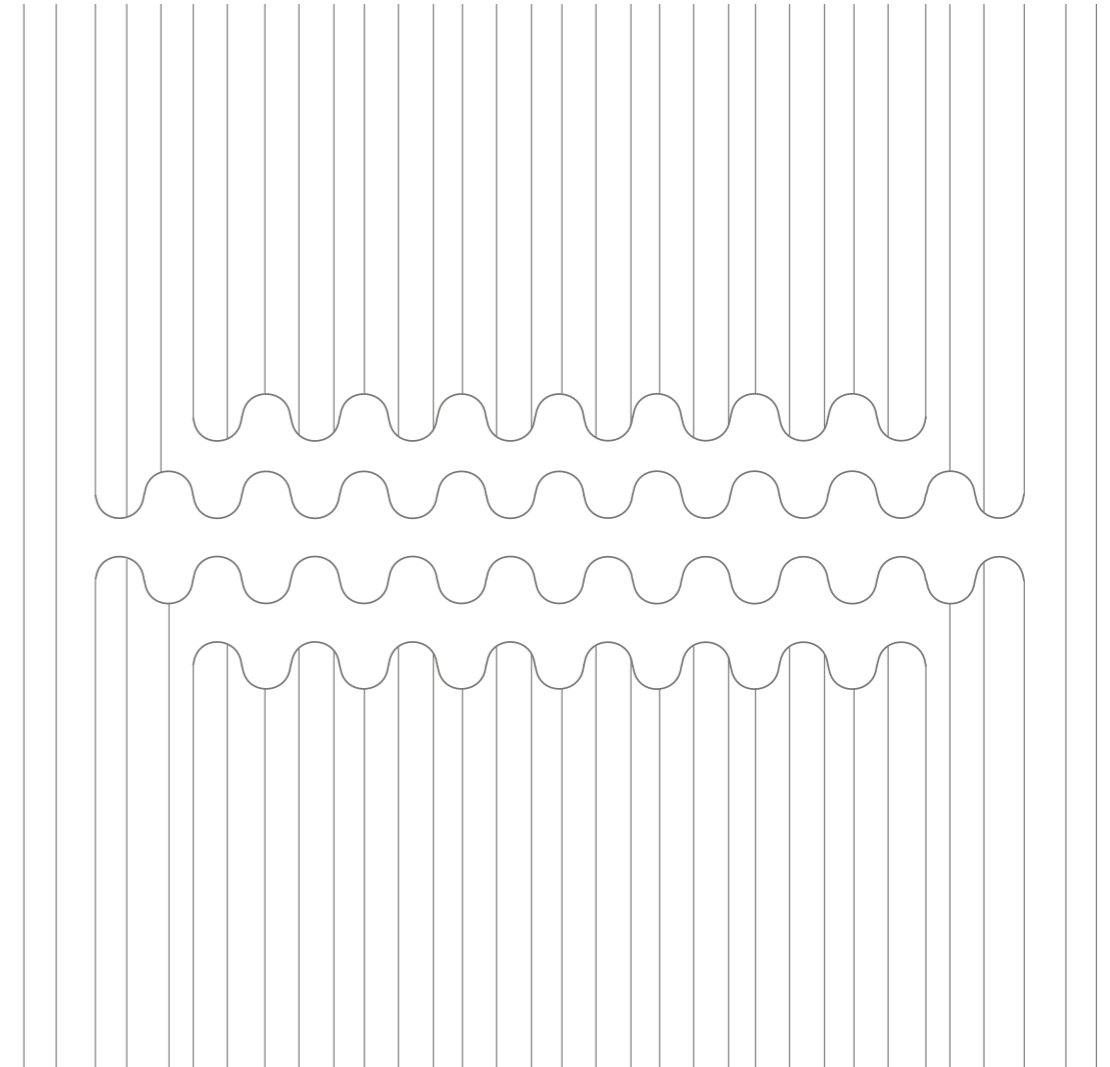

CHAPTER 2
MATERIALS & GENERIC SPACE



Hand-blown glass

THEORETICAL REFERENCES

FRAME AND THE GENERIC SPACE BY BERNARD LEUPEN, 2006.

To be able to answer the aim of this thesis, theoretical sources that deal with how we interpret the built environment, flexibility and general spaces, as well as dramaturgy in architecture have been read. This, to create a deeper understanding of how buildings and spatiality can be experienced and interpreted, as well as how general spaces can enable a wider use. In addition, to find tools to be able to investigate how the experience of a space can change with the help of different room compositions.

LEARNING FROM LAS VEGAS BY VENTURI R., SCOTT BROWN D., & IZENOUR S, 1972.

“*Learning from the existing landscape is a way of being revolutionary for an architect. Not the obvious way, which is to tear down Paris and begin again, as Le Corbusier suggested in the 1920s, but another, more tolerant way; that is, to question how we look at things.*” (Venturi, Scott Brown & Izenour, 1972, p.3).

In the book *Learning from Las Vegas* (1972), the authors highlight one statement from Jane Jacobs which was about not looking for the answer in the key element of a building. Jacobs meant that it is the mixture in the city that is the king pin, and its mutual support in the order. The authors emphasize the fact that our surrounding environment is saying different things to us and in their examples, they are analyzing the built environment in Las Vegas. Buildings that often, as they call it, are decorated sheds. From big signs and lightning, the buildings behind are highlighted, but when looking at the architecture it is nothing more than a shed, a decorated one.

In the book, the authors analyze, among other things, two different residential buildings. One that is described as a decorated shed, with its ironic ornamental-symbolic elements, whereas the other is described to be more truthful in its design. Furthermore, the authors discuss what really is a decorated shed and symbolic architecture. One of the buildings described above, first appears to be a truthful building, honest to its structure and function. However, according to the authors modern architecture has become a dry expressionism, in other words empty and boring. For example, by limiting the building to its strict articulations of the pure architectural elements of space, program, and structure. They argue that today’s modern architecture, which rejects obvious symbolism and ornamentation, consequently, has misrepresented the whole building into one big ornament itself.

To summarize, the authors believe that today’s architecture has evolved to either be decorated sheds or symbols in themselves. Where they believe that it is time to reevaluate the statement, that architecture is a decorated construction, but to remember the difference between decorating a construction and constructing a decoration.

By analyzing the built environment on Ringön, with the help of the theories explained above, a simpler division of the built environment was made possible. In addition, created a broader perspective on the area, as well as clarified Ringön’s architectural identity. With the help of the authors’ theories, their approach contributed to inspiration and innovation of the design proposal.

The book *Frame and the generic space* (2006) addresses different definitions of what makes a generic space, that is, a room that can be used for multiple purposes and is flexible to change. Leupen believes that what provides the conditions for a generic space is the *frame*.

Leupen’s frame concept describes, among other things, how the frame, with the help of its independence, contributes to the other parts of the building becoming free from permanence. For example, by the frame being the load-bearing structure in the building, it can expose the walls from being load-bearing and thus also enable its flexibility within the building’s frame. “... *it is the unchangeable that creates the conditions for changeability, the permanent that frees the temporary*” (Leupen, 2006 p.23). However, he believes that even if the frame exposes the other components of a building, it is by creating a space from the start that requires minimal adaptation for flexibility that an optimal use of the building can occur. Leupen divides a building into five different layers, *the structure, the skin, the scenery, the services, and the access*. All of these layers can function as the frame. By deciding which one of these that needs to be the permanent, the other layers can shift. Five layers five frames. In summary, Leupen believes that the more we can formulate what it is that is permanent within a building and give it meaning, the more space the changing aspect has in which to expand. He says, to design for the unknown, is to design out of the permanent.

To reach an answer to my purpose regarding movement and flow, Leupen’s theories about what is permanent and what is changeable have been useful. Leupen emphasizes that it is at the beginning that you give the building its prerequisites, which has been a valuable tool in the design process. His theory can be applied in several ways, which also has been a useful tool for analyzing the built references.

THE DRAMA OF SPACE BY HOLGER KLEINE, 2018.

According to Holger Kleine (2018), the experience of architectural spaces is shaped by how they are staged. By using different methods in architectural design, varying experiences of a space can be obtained. In the book *The drama of space*, the author and architect Kleine develop a systematic approach to architecture, where the approaches are based on the concept of “dramaturgy”. The book is divided into four parts and begins with *sequences of surfaces*, in which Kleine establishes the basic principles of dramaturgy. This is followed by *the formation of rooms*, where he exemplifies different delimiting surfaces, which he calls archetypes, such as the cave, portal, basin, and the hood. The third part is called *sequences of rooms*, here he examines the dramaturgy in sequences of rooms. Lastly, Kleine introduces *spatial configurations*. In the last chapter, he discusses spatial configurations and how they affect the architectural dramaturgy. Within each chapter, several categories follow, which analyze different components of the building’s composition. In the last section, Kleine goes through various elements that can serve as frames for designing “the drama of space”, he divides these into space, time, and body.

To reach an answer to my sub-question, Kleine’s theory has served as a design tool in the investigation of architectural experience. By applying his theories from the sub-chapter on configurations, proportions and paths, interesting analyzes of the exhibition hall were made, which contributed to a deeper understanding of dramaturgy in architecture, as well as a greater understanding of the importance of the basic layout of an exhibition space.

BUILT REFERENCES

To reach an answer to my thesis question, it was important to study specific examples to create a greater understanding of its complexity. As the project consists of a glasswork, and an exhibition hall, it was essential to study both building typologies. In addition, a modern industrial building has been analyzed to provide inspiration for the project and contribute to a broader perspective. The specific buildings that have been analyzed were chosen after the building volume was determined to create a deeper understanding of the flow and movement in and between the different functions. In addition, the buildings' choice of materials was also analyzed, and how the choice of materials can simplify the work in a workshop and enhance the experience of an exhibition.

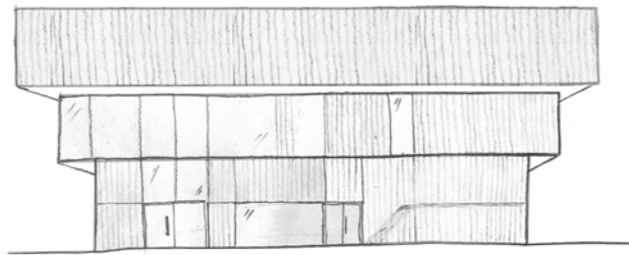

REFERENCE BUILDING

Pavilion Z / A8000, 2021

This building is an exhibition center in České Budějovice, called Pavilion Z renovated by the architectural studio A8000 in 2021. Pavilion Z has undergone various changes over the years, but when architects A8000 took over, they restored the original minimalistic appearance of the pavilion. The design is based on the building's original shape and consists of three enlarged blocks. The two lower blocks contain the floor levels, with a transparency in the facade, while the upper block is closed and functions as a roof (A8000, 2022)

The building's shape is characterized by airiness, with both open and closed parts. To the west one will find the more enclosed parts, while the open and freer spaces are to be found in the east. The large exhibition hall is designed as a multifunctional space and can be viewed from two levels. To enable a more flexible use of the open sections, these can be separated with curtains, which also enables the exhibition hall to function as a black box (A8000, 2022). The interior follows a white-and-black color concept, which according to the architects allows freer use. In addition to the color concept, the building consists of profiled glass, which creates a soft and warm impression in the premises. The floors are made with polished concrete. Externally, the building is perceived as clean and uniform in its expression, while a more modern expression is found in the interior.

By dividing the building into open and closed spaces, the architects created a freer and greater flexibility for the open spaces, which inspired the project's exhibition hall. In the reference project, the multifunctional space can be seen as the "frame", where the other parts of the building can change. In addition to the flexibility of the exhibition hall in Pavilion Z, there is a circular movement on the upper floor that invites one to explore more spaces. The circular movement has inspired design choices in the project proposal.

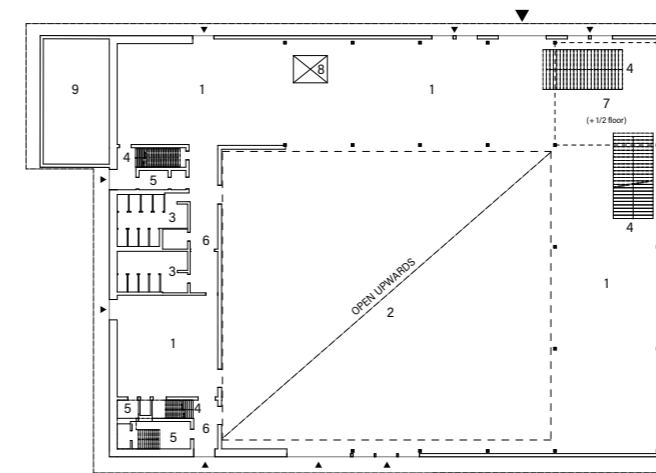

FIRST FLOOR

1. Entrance hall/foyer
2. Exhibition/multifunctional space
3. WC
4. Stairs
5. Storage/Undefined space
6. Corridor
7. Intermediate floor
8. Elevator
9. Undefined space

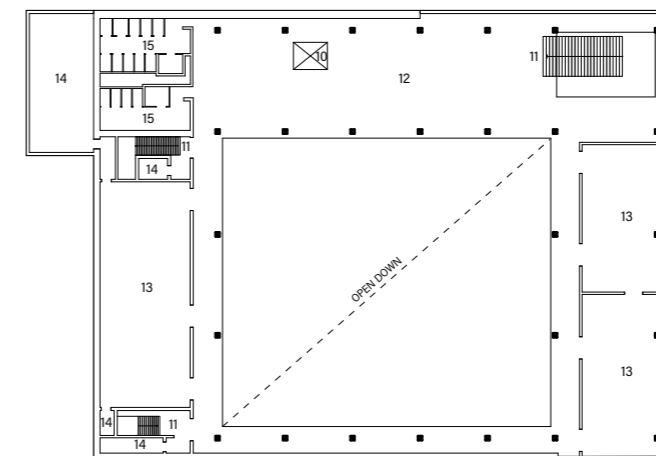

SECOND FLOOR

10. Elevator
11. Stairs
12. Balcony
13. Exhibition/Flexible space
14. Storage/ Undefined space
15. WC

SCHEMATIC FLOOR PLAN
NO SCALE

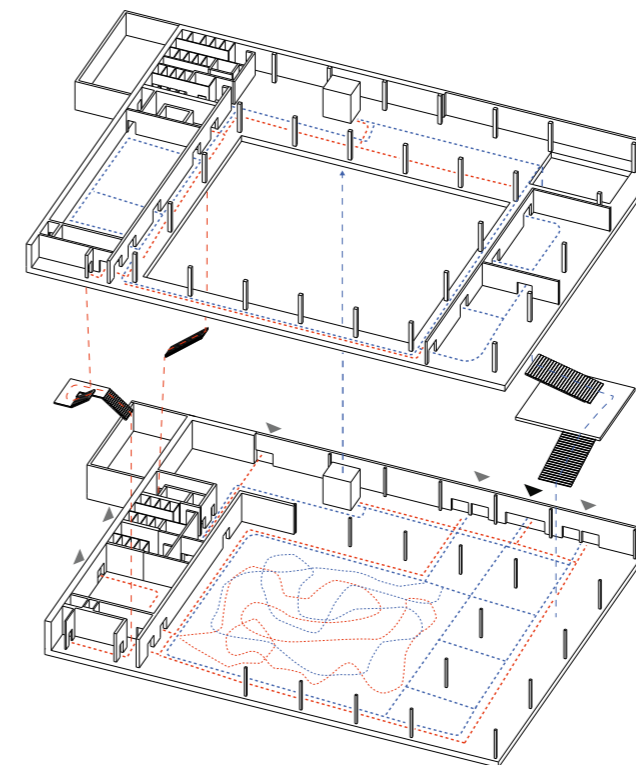

EXAMPLES OF MOVEMENTS
- - - MOVEMENT STAFF
- - - MOVEMENT VISITORS

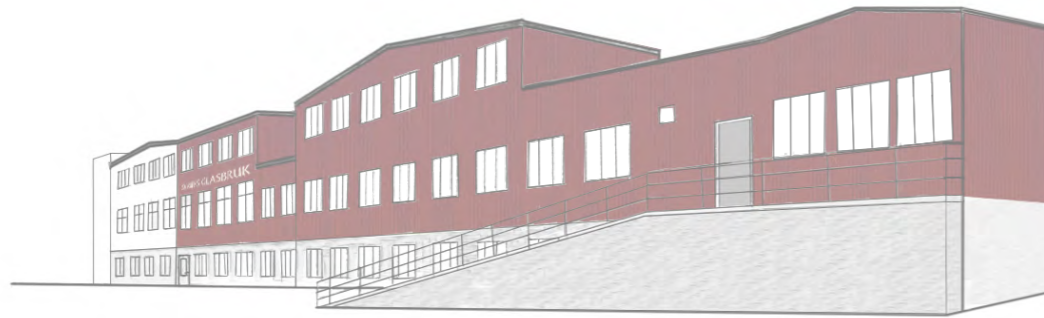

REFERENCE BUILDING

SKRUF glasswork, 1897.

This building is located in the small community of Skruf in Sweden. It was during the late 19th century that the founder Robert Celander chose to develop a glasswork in the area. Today, the glasswork is owned by the Elm family, which carries out modern glass production by hand. All products from Skurf are manufactured here and are shipped worldwide. Skruf has several famous artists, who either work full-time at the glasswork or who come in as guest artists (Skrufsglasbruk, 2023).

According to Kent Elm (personal communication, January 27, 2023), the flow in a glasswork is of great importance. Often it is different people that work in the workshop and in the cold- and technical workshop, hence clear and easy communication between them is important. When Elm took over the glasswork, some relocation of functions took place, to facilitate the flow and contribute to a better work environment for the employees. In addition to production, inventory management and sales are important areas, which also is dependent on good contact with the workshops.

The building is constructed with a concrete frame, which is built with various materials at different stages, from bricks to plaster, and wood paneling. The building mainly consists of concrete floors, where the workshop receives rubber asphalt to contribute to a better work environment. Moreover, windows are an essential part of the workshop. In Skruf's workshop, there are large glass sections to the west, as well as skylights to easily ventilate excess heat from the ovens. Skylights can also be found in the cold- and technical workshop. The energy use of a glasswork is relatively high, depending on the choice of furnaces. To reduce energy costs, Skruf has chosen to use both gas- and electric ovens. The gas furnaces generate more heat, where Elm has applied pipes above the furnaces to transfer heat from the hot workshop to the cold one. The electric oven does not generate as much excess heat, and is more efficient, on the other hand, more energy demanding. Depending on the size of the glasswork and its production, the choice of furnaces differs.

To summarize, in a glasswork, the energy use and the flow between different functions are of great importance, as well as the choice of materials for a good work environment. Since Skruf's premises were built at the end of the 19th century when the use of the glasswork was different, there is much that had been done differently today, says Elm.

The interview with Kent Elm and the site visit at Skruf provided inspiration for the layout of the glasswork. The built reference is a good example to understand the space program of a glasswork, as well as how the movement and flow in a workshop work. In addition, the importance of daylight and ceiling height in the workshop, together with efficient energy solutions.

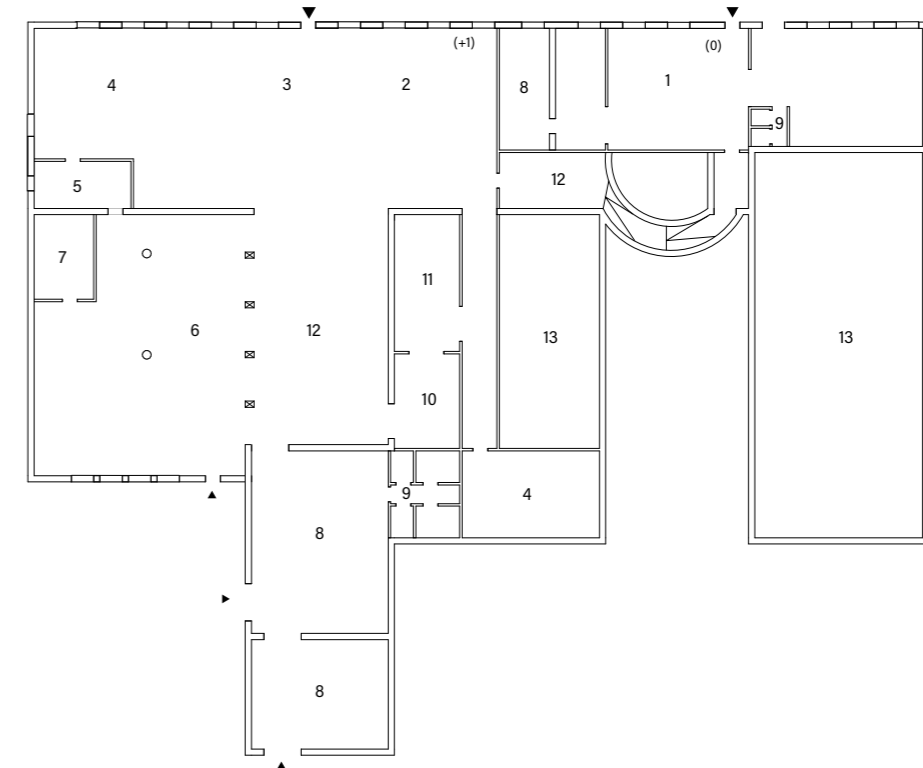

FIRST FLOOR

SCHEMATIC FLOOR PLAN
NO SCALE

- | | | | |
|-----------------------|------------------------|----------------------------|-----------------------|
| 1. Store | 5. Office | 9. WC/shower | 13. Space, not in use |
| 2. Packaging area | 6. Workshop | 10. Tools/storage | |
| 3. Cold workshop | 7. Lunch room | 11. Technical room/storage | |
| 4. Technical workshop | 8. Storage/loading bay | 12. Communication | |

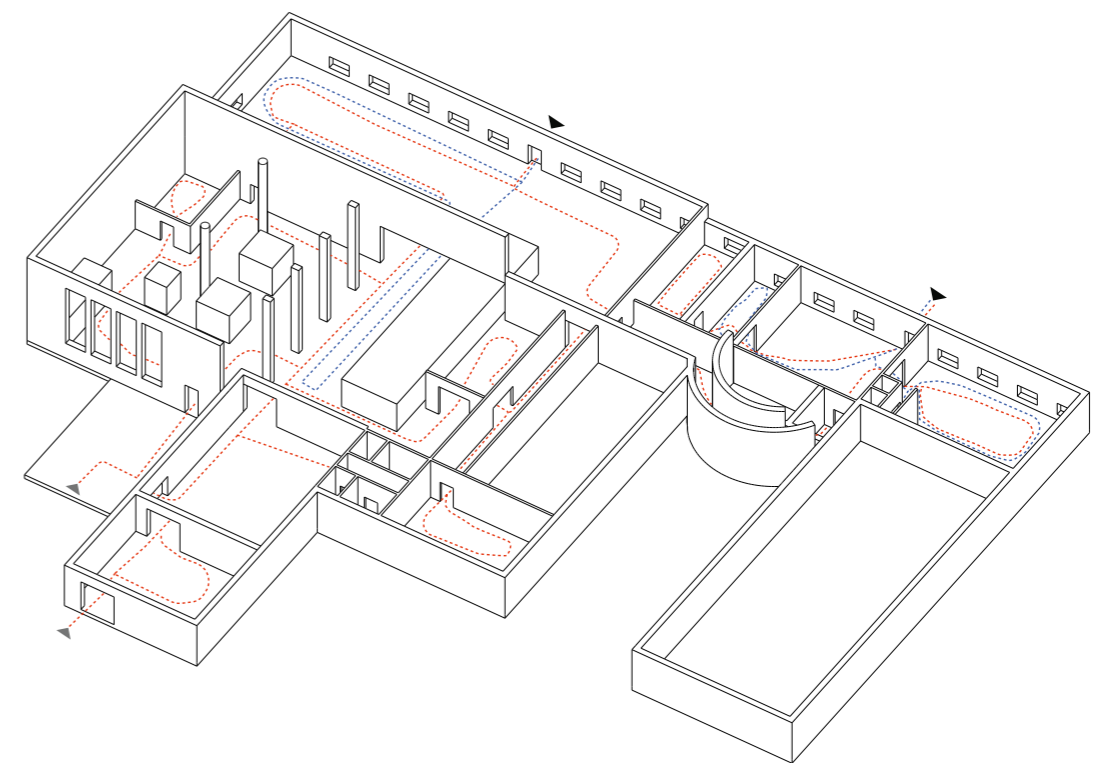

EXAMPLES OF MOVEMENTS
- - - MOVEMENT STAFF
- - - MOVEMENT VISITORS



REFERENCE BUILDING

Vitsø headquarters and production facility, 2017

This building is the headquarters and production facility for the furniture company Vitsø, located in the city of Royal Leamington Spa, in England. The building consists of a modular construction, which allows the building to be easily updated, and with a sawtooth roof. The building is 125 meters long and 25 meters wide, with a building height of 6 meters. The pillars are placed at a distance of 7.2 meters in the longitudinal direction and 4.8 meters towards the center (Griffiths, 2017).

The furniture company is best known for its modular storage systems, where “systems thinking” is one of their concepts. This concept was applied to the building, to create an extension between their business and the building’s design. According to the company, the facility is the first of its kind in the UK to use a framework made from beech laminate-veneer lumber (LVL). The advantage of the laminated structural timber of hardwood is that a greater strength in the beams can be obtained, as well as the possibility for neater columns (Griffiths, 2017). According to the company is the choice of material and construction not only an environmentally conscious choice, but also to facilitate modifications in the future. Beams, columns, and joists can be dismantled and reconfigured, where parts can be added or removed. The walls and roof consist of cross-laminated wood, which gives good thermal properties. The steel used in the glazed roof structures was chosen for its structural properties as well as its industrial feel (Griffiths, 2017).

The building’s design is adapted to have a strong connection to the surroundings, with large windows that frame the view of the landscape, as well as allowing passers-by to catch a glimpse of their production. The skylights face north and allow daylight to flow into the work areas. In summary, the building is inspired by industrial buildings from the past, as well as the production methods of the future. The system building follows the norm of “form following function”, but where function has a broader meaning than before (Griffiths, 2017).

To answer the purpose of the thesis, how the industrial environment on Ringön can contribute to a design proposal, Vitsø was a good example of how a modern, flexible, and environmentally friendly industrial building can be built. The open floor plan allows for flexible use, where the volume of the building allows for future additions of space. The construction materials used provided inspiration for the design proposal and show how a wooden construction can contribute to greater flexibility and changeability.

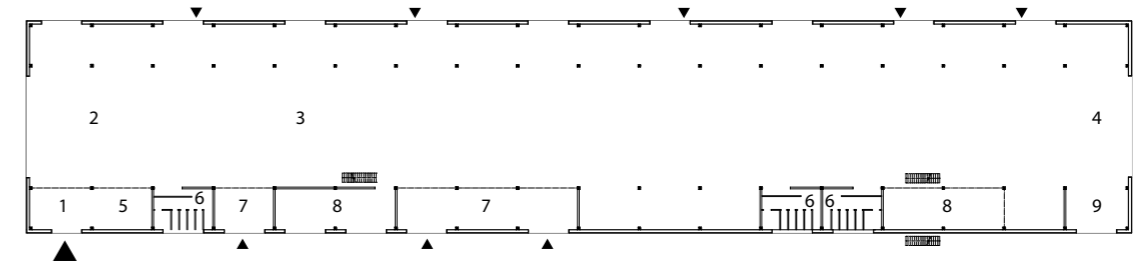

FIRST FLOOR

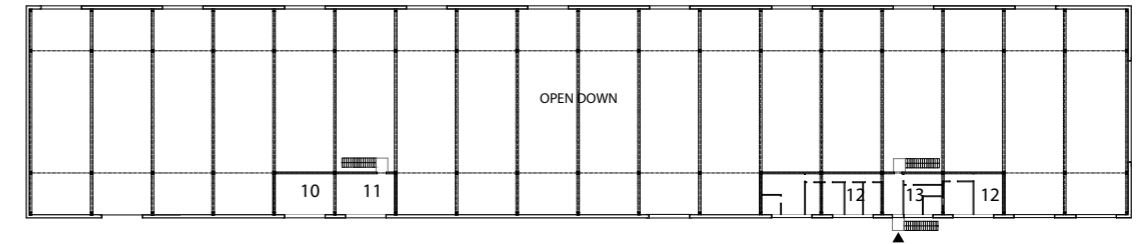

SECOND FLOOR

SCHMATIC FLOOR PLAN
NO SCALE

- | | | | |
|------------------|------------------|-------------------|-------------|
| 1. Main entrance | 5. Cycle storage | 9. Kitchen | 13. Laundry |
| 2. Assembly zone | 6. WC/showers | 10. Plant room | |
| 3. Packing zone | 7. Loading bay | 11. IT-room | |
| 4. Dining area | 8. Archive | 12. Accommodation | |

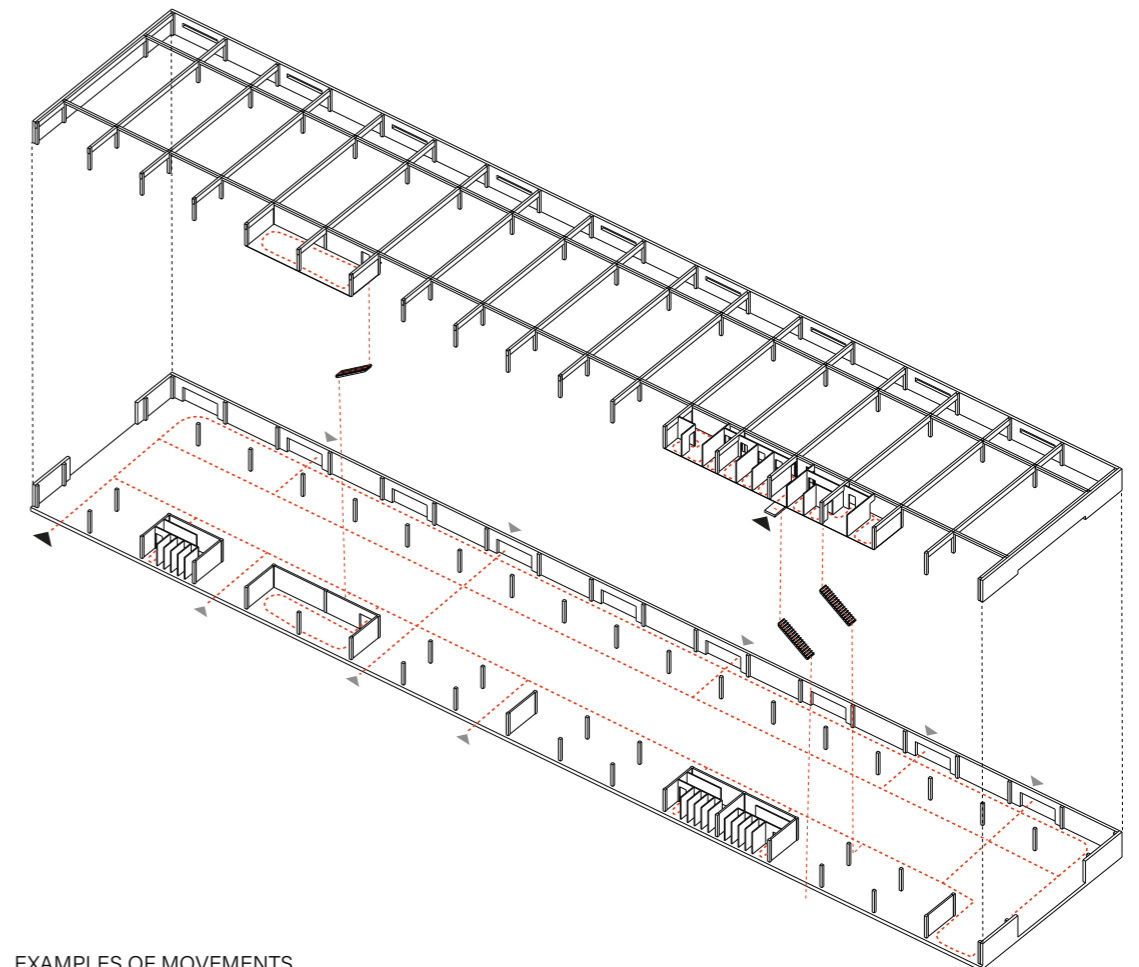

EXAMPLES OF MOVEMENTS
- - - STAFF

CHAPTER 3
THE SITE

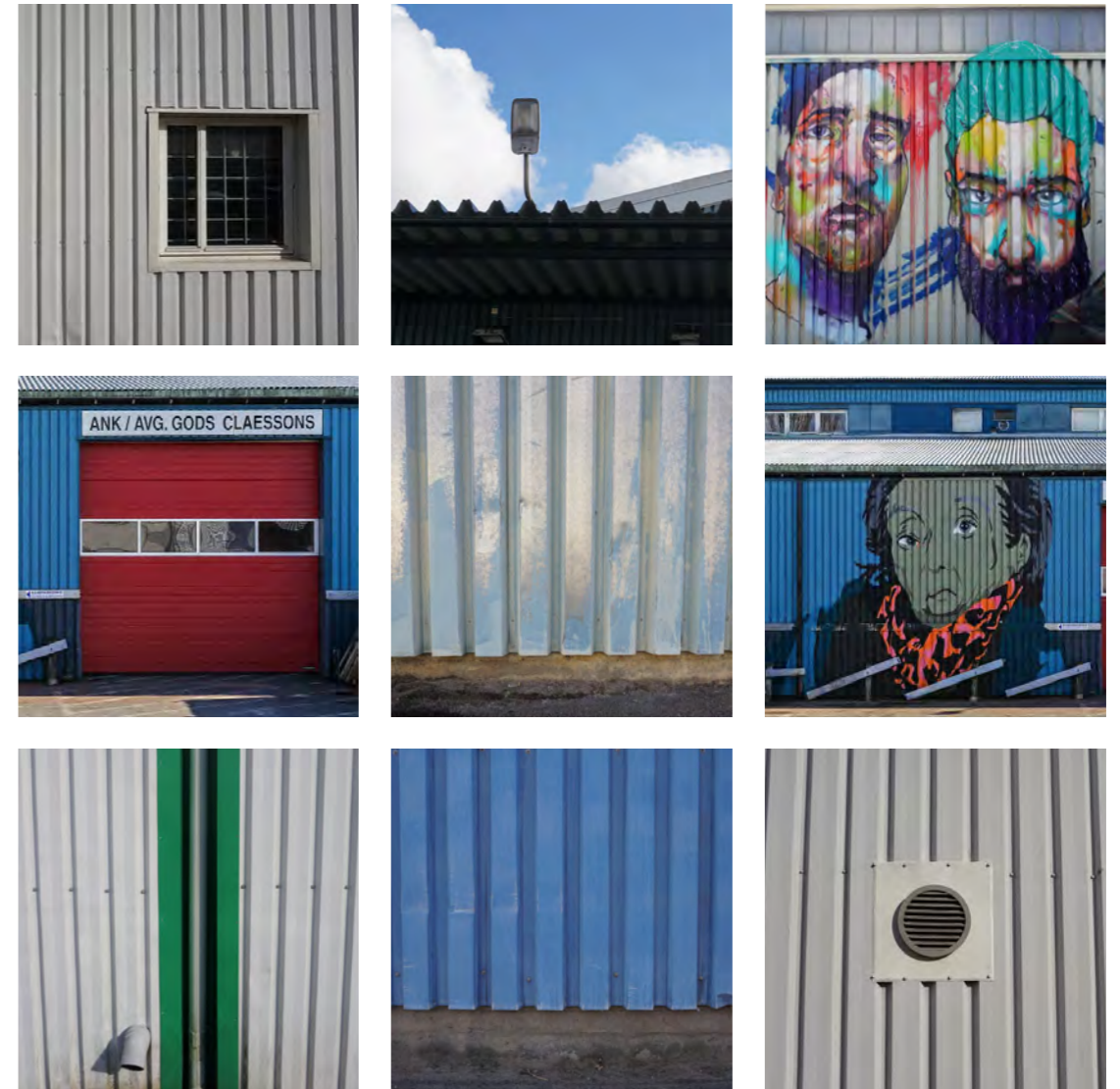

Details from Ringön



RINGÖN OVERVIEW, SCALE 1 : 10 000



SITE ANALYSIS

Today, Ringön is an area that contains a range of different activities and functions. In the area there are, among other things, municipal warehouses for materials and recycling, where some occupy half a block of land. Next to this one can find small creative businesses, from art studios to microbreweries. In summary, everything from music to concrete is produced on Ringön, where some people and businesses have been in the area for generations.

Ringön's character can be summed up as a mix between old and new, organized and chaotic. A mixture that also gives the area its identity.

- — The area, Ringön
- ■ Main path
- Suggested location for proposal
- Public transport, tram
- Public transport, bus line
- ⚓ Marina

From an interview with Åsa Hüffmeier (personal communication, November 8, 2022) at the city planning office in Gothenburg, a challenge for the area is, among other things, communication. Since Ringön is seen as an industrial area, the connection and public transport are also dimensioned for the old need and not for the new ones. Along the main road Ringögatan, formerly Ringkanalen, many new businesses in the area can be reached. However, this street is more adapted to car traffic and higher speed said Hüffmeier. On certain streets, such as Gjutjärmsgatan and Järnmalmsgatan, one can see rows of trees, remnants of what were once avenues. On the smaller streets, there are both large and small businesses, as well as empty spaces and/or spaces cluttered with rubbish or stockpiles of material, places that also have to exist in a city, Hüffmeier said. As part of the development of Ringön, two pocket parks have been designated near the water which was an important approach in the development of the area, she believes.

The topography on Ringön is relatively flat. The land closest to the water is about one meter above the water's surface, while the buildings further away are approximately two to three meters above. The proposed location is currently two meters above the water's edge. In the event of sea level rise, the quay closest to the site can act as a barrier. Furthermore, according to Robert Eriksson at Västprojekt, the plot owner, is the site not prone to flooding (personal communication, November 2, 2022). However, piling is a requirement to be able to build. Another condition is that the new building must contain some form of production. The possibilities for the proposed location are many, says Eriksson. The detailed plan allows a building up to seven thousand square meters, which enables a range of different types of businesses.

SITE ANALYSIS

According to Eriksson (personal communication, November 2, 2022), the site has housed various types of businesses. In recent years, Santa Maria has used the site as a warehouse, after that a bed company took over and used the place for offices and sales. Cleason's Wood Tar was the last business on the location. They used the property for about 20 years before it burned down in 2021. Today, the site is cleared up and empty, waiting for a new business to appear on the plot.





The previous building on the site had a characteristic blue tin facade, which can be found in several places in the area. Pictures sent by Eriksson, clarified the former building's window placement, which was found at the meeting between the eaves and the wall (personal communication, November 2, 2022). The windows provided good daylight but marked that what went on inside the premises would not be visible to the outside, which is a common feature of the industrial development on Ringön. Furthermore, another common feature on Ringön is large doors and gates, something that also was found around the former building. Compared to the hidden windows, the large doors gave the expression of wanting to be seen, with a strongly contrasting color against the facade. Lastly, the construction in the previous building consisted of a wooden frame, of glulam beams, which enabled large spans and flexible use. The foundation was made of cast-in-place concrete, while the joists in the smaller office building consisted of wood.

The sites total area is 3191 sqm and the current building permit is 4500 sqm. Overall is the total buildable area 7000 sqm, where the former footprint was 2990 sqm.

The surrounding buildings contain varying functions and activities. Near the site is a paddle center, and different kinds of shops as well as a car service, a brewery, and a hotel. In addition to this one can also find an art gallery, and a film studio close to the plot. Besides buildings, there are cultivation plots, a pocket park, and a marina near the site.

FUNCTIONS

- | | | | |
|---|----------------------|----|---------------|
| 1 | Art gallery | 7 | Office |
| 2 | Brewery | 8 | Paddle center |
| 3 | Car service/dockyard | 9 | Park |
| 4 | Farming | 10 | Restaurant |
| 5 | Film studio | 11 | Storage |
| 6 | Hotel | 12 | Trade/shop |

-  Main path
-  Secondary paths
-  Boat routes
-  Suggested location for proposal
-  Marina



The previous building

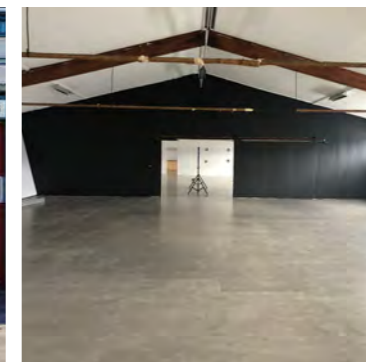

Glulam beams



The small office building

Pictures from Robert Eriksson (personal communication, November 2, 2022)

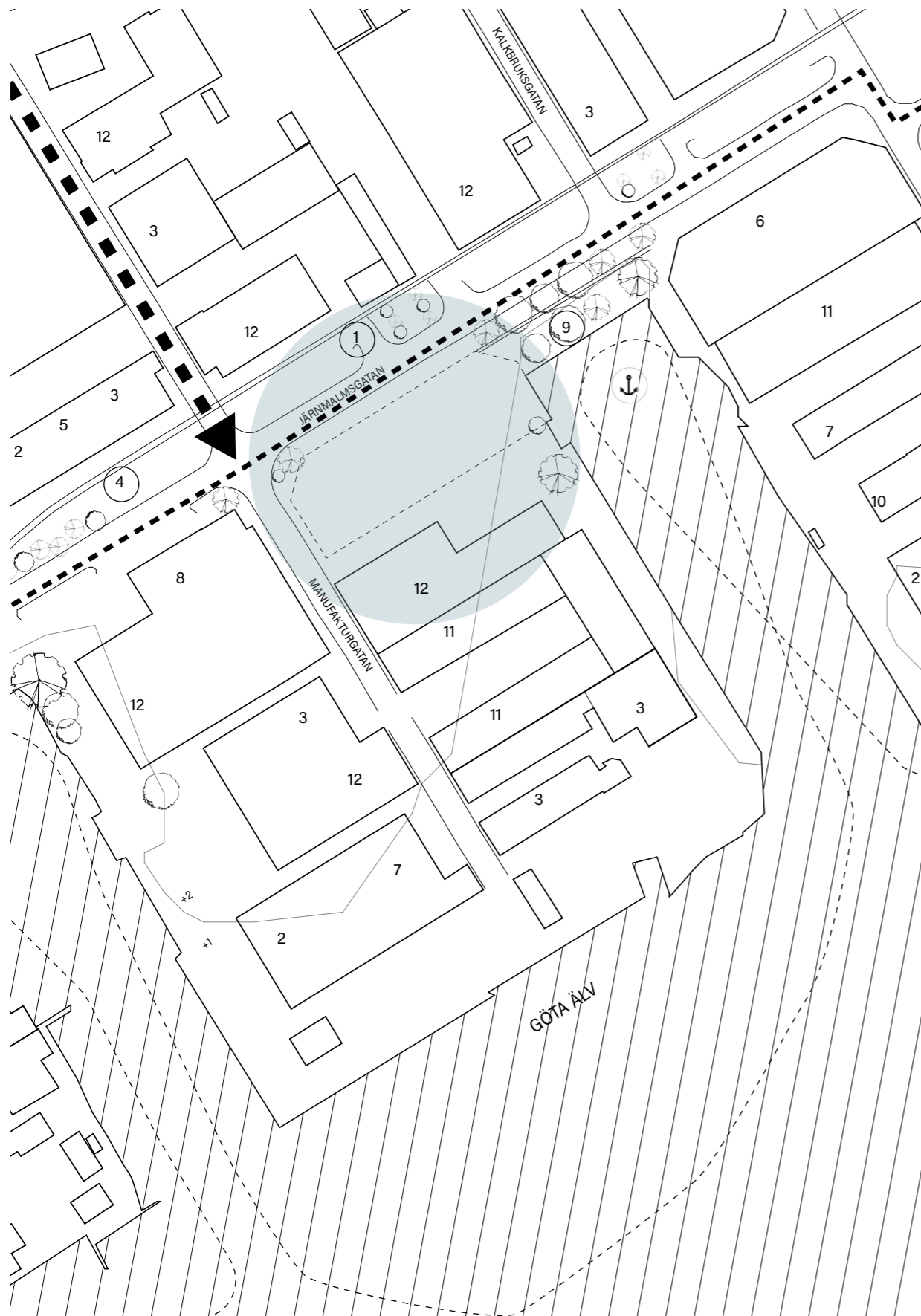

SITE OVERVIEW, SCALE 1 : 2 000



ARCHITECTURAL OBSERVATION

The architecture on Ringön is a mix of large and small buildings, a multitude of variations and additions. There is a certain difficulty in describing the architecture, as many of the buildings mainly look like assembled boxes, adapted to their activities. Projecting canopies, large signs, numerous chimneys and ventilation hoods as well as high fences and gates. From an architectural perspective, it is difficult to describe a type of building in this area that has any kind of exterior architectural quality, it is rather the mix and the history of the area that has any significant role.

When analyzing the architecture, parallels to *Learning from Las Vegas* (1972) were made. Several buildings can be described as decorated sheds, simple volumes with large signs that ornament the buildings. In addition, some buildings are more subdued in their expression, where neither the details nor the volume reveals their content. At a quick glance, you do not know if these buildings are in use or not. These buildings can neither be described as decorated sheds, nor symbols of themselves. Perhaps it is precisely these buildings that are the most interesting in the area.

The building volumes are simple and clean, where the roof ridges vary in placement and create variation in the area. Since the detailed plan for Ringön has a maximum height of eight to twelve meters the development is perceived as relatively low. On the other hand, some buildings stretch over an entire block, which in turn contributes to the size and volume of the buildings being perceived as larger. The placement of windows around the buildings in the area varies. As many of the businesses carry on some form of industrial activity, the windows have been placed higher up from street level. Common window placement is found in the meeting between the wall and the eaves, and or on the roof.

Various facade materials can be found in the area. The most common is sheet metal, where the sheet metal is either bent, corrugated, or sine-corrugated. In addition, brick, wood, and concrete elements can also be found. Just like the variety of materials, there is a variety of colors. Common colors on the sheet metal are blue, white, and yellow, as well as black, green, and grey. The brick varies between yellow and red, and the wooden facades differ between red, gray, or yellow. When you examine the area more closely, you can find even more materials and colors, where creativity has been allowed to flow freely.

Below follows a short listing of characteristic architectural elements, which I took with me as inspiration in the design process.

- *Clean and simple volumes.*
- *A color palette, consisting of grey, white, and blue.*
- *Vertically mounted sine-corrugated sheet metal.*
- *Closed facades, on human scale.*
- *Concrete, as facade material, foundation, and as paving.*
- *Low-sloping roof.*
- *High-set windows, with only a few windows at street level.*
- *Large doors and gate openings.*

VOLUMES AND ROOF ANGLES OBSERVED IN THE AREA

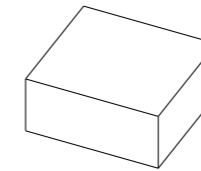

FLAT ROOF

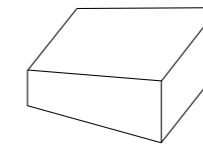

PULPET ROOF

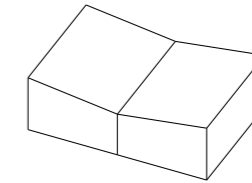

V-SHAPED PULPET
ROOF

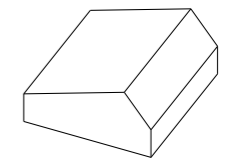

OFFSET ROOF RIDGE

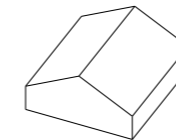

GABLE ROOF

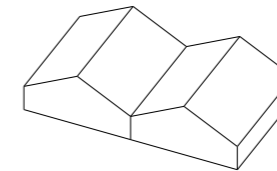

M SHAPED - GABLE ROOF

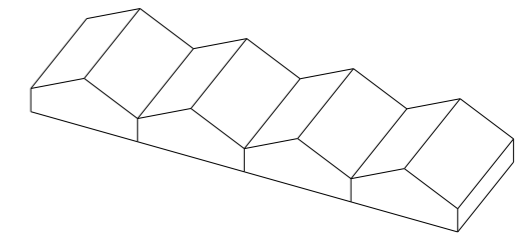

REPEATED - GABLE ROOF

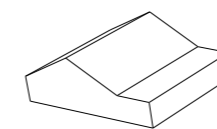

GABLE ROOF
+
FLAT ROOF

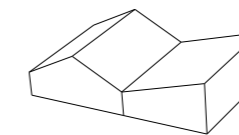

GABLE ROOF
+
PULPET ROOF

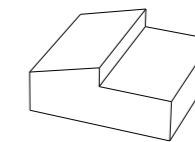

OFFSET GABLE
CLERESTORY
ROOF

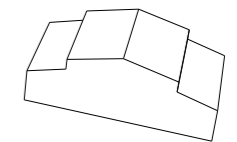

CLERESTORY
GABLE ROOF



ARC PROFILE

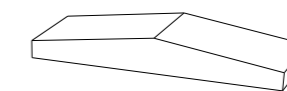

EXTENDED GABLE ROOF

CHAPTER 4
PROPOSAL



The project proposal - View through the sculpture park towards the entrance

CONCEPT

The concept has been developed with the help of the previously mentioned analyses and the observations made in the area. The shape of the building is designed as a block, with a flexible construction in wood that enables a wide use of the spaces. By working with a grid, the construction can act as the “frame”, the permanent part of the building’s design, where the other parts can change and adapt over time. The rooms can be designed in several ways, where the use of the room is what decides its composition.

The main concept consists of enlarged blocks, where the first floor consists of the basic principle of the building. The second floor is displaced by 1.2 meters and the third floor by 2.4 meters. The cantilevered floor plans are based on the grid and can be dismantled in the future. This is made possible by placing the load-bearing structure within the cantilevered parts, which also contributes to greater flexibility and adaptability for future needs. Additionally, a light yard is created in the middle of the building, to accommodate a good working environment in the workshop.

The secondary concept can be described as *identity creation* and can be explained as a gradient between open and closed. The function of each floor is what determines its transparency in the facade. The first floor receives a more closed façade, connecting to the surrounding areas character, and contains the glasswork, as well as a reception and sales. To enable a connection between the sculpture park and the visitor entrance, one gable side has been given a more glazed facade. On the second floor, the facade is transparent and contains creative functions, education, and a bar. Here, the activities are directed both inwards and outwards. On the third floor, the facade is semi-transparent, where the direction is mainly focused inwards, but with a few openings facing outwards. By working with different transparencies in the façade, the building receives three different identities, as well as contributing to a modern interpretation of the traditional closed industrial building with high-set windows.

The façade has been inspired by the surrounding industrial character. The doors to the main entrances imitate the large gates found in the area, the same applies to the choice of façade material around the ground floor. To create a more closed facade towards the street, these windows have a perforated sine-corrugated sheet metal in front of the openings. On the second and third floor the façade transitions into large glass sections, with vertical aluminum details. The vertical details have been inspired by the sine-corrugated sheet metal, which creates a modern interpretation of the wavy shape of the facade material.

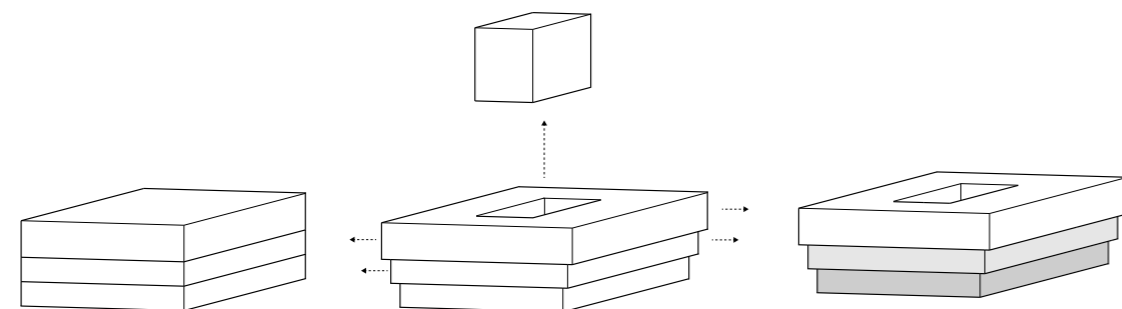

BASIC PRINCIPLE

ENLARGED BLOCKS - LIGHT YARD

IDENTITY

BUILDING CONCEPT

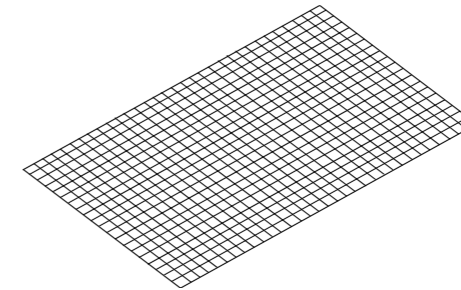

GRID 1,2x1,2 METER

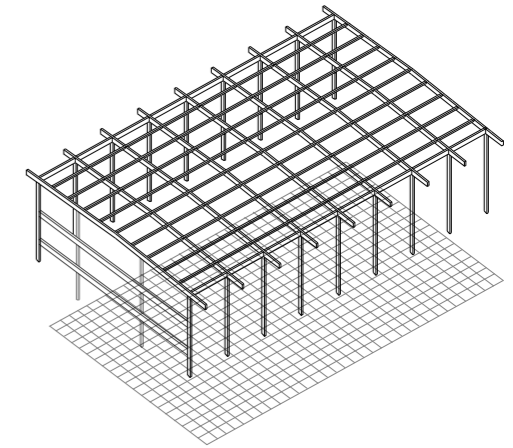

PILLAR AND BEAM SYSTEM

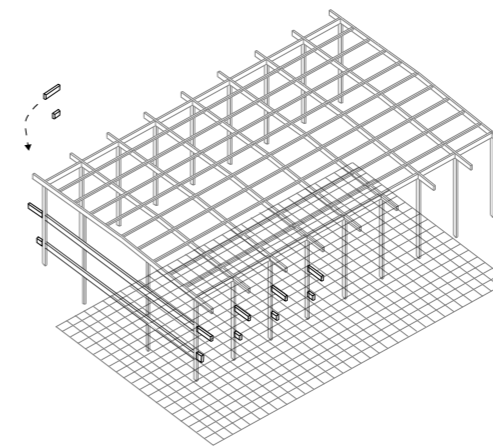

ADDITION OF SUSPENDED CONSTRUCTION

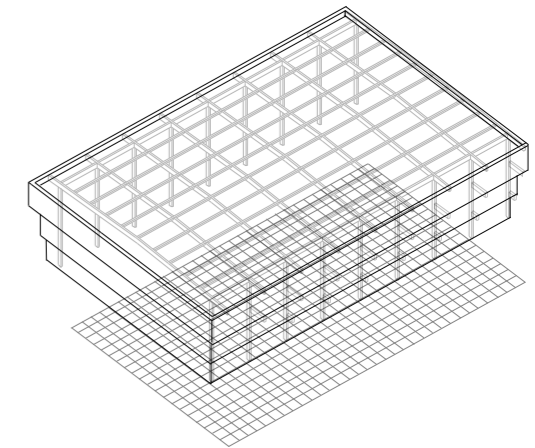

CURTAIN WALL ON LOAD-BEARING STRUCTURE

PROPOSAL

The site of the proposed glasswork and exhibition center is located in the middle of Ringön, near the water. The plot is today empty since the former building burned down in 2021. The location was chosen because Ringön is a part of Gothenburg where production and workshops are possible and has a freer detailed plan. In addition, the area consists of several properties with creative activities, and adding a glasswork with an associated exhibition center was something that felt natural for the place. The building is oriented in a north-west direction, with the main entrance to the north-east.

The exhibition center functions as a link between the production and the other activities on Ringön, as well as a link between other parts of Gothenburg. In addition to the exhibition and glasswork, there are premises for sales, such as a shop and a bar, as well as premises for education. The store is dedicated to the production, while the bar opens the possibility for a collaboration with the microbreweries that are located on Ringön today. The educational rooms are intended to act as a link between the glasswork and the art schools in Gothenburg. In this way, the proposal has a connection within Ringön and its activities, as well as with the city of Gothenburg.

The building's main entrance is located on the gable, in the north-east and has a good connection to the sculpture park, the marina and the pocket park outside. For the visitor, the entrance begins at the street, where one will meet a gravel path with large concrete slabs, partly made of recycled concrete. The concrete slabs are also used to create a sculpture park. The sculpture park contributes to a creative framing of the outdoor environment, and creates a connection to the area's port and industrial character.

Directly inside the entrance, the visitor is greeted by a view towards the glasswork and the staircase. To the right one will find the reception, as well as a wardrobe and toilets. The shop is located to the left of the entrance, where the visitor can take part in the glass art produced in the workshop. The glasswork is located in a light yard, which contributes with good daylight and the opportunity to ventilate excess heat. The workshop's lunchroom and changing rooms are well connected to the glasswork, as well as the staff entrance, which is found on the south-west gable. The remaining part of the first floor consists of storage areas, a small office as well as technical spaces and a garbage room.

As the visitor moves toward level two, they are greeted by a bar with a view down towards the sculpture park, the marina, and the workshop. The second floor contains the glasswork's creative spaces, such as studios and offices, as well as two educational rooms. The educational rooms have a good connection with the glassworks' studios and have a view down towards the glasswork. Additionally, this floor also contains changing rooms, a lunchroom, and storage, as well as spaces connected to the bar.

The third floor consists of a flexible exhibition space, which can be furnished in several ways. Here the windows are frosted, with a few windows in clear glass that contribute to a simplified orientation. The third floor also contains staff communication, emergency exit, as well as storage and toilets for the visitors. Here, too, the visitor has direct contact with the glasswork via windows around the light yard.

In summary, the proposal contains four different parts. An outdoor environment containing a sculpture park that connects the contents of the building with the existing pocket park and marina, as well as a ground floor containing glass production and sales. The second floor contains creative and social spaces, and the third floor consists of an exhibition hall. The glasswork has been the driving force in the design process, where great importance has been placed on each floor being able to take part in the glass production.



The project proposal - Main entrance

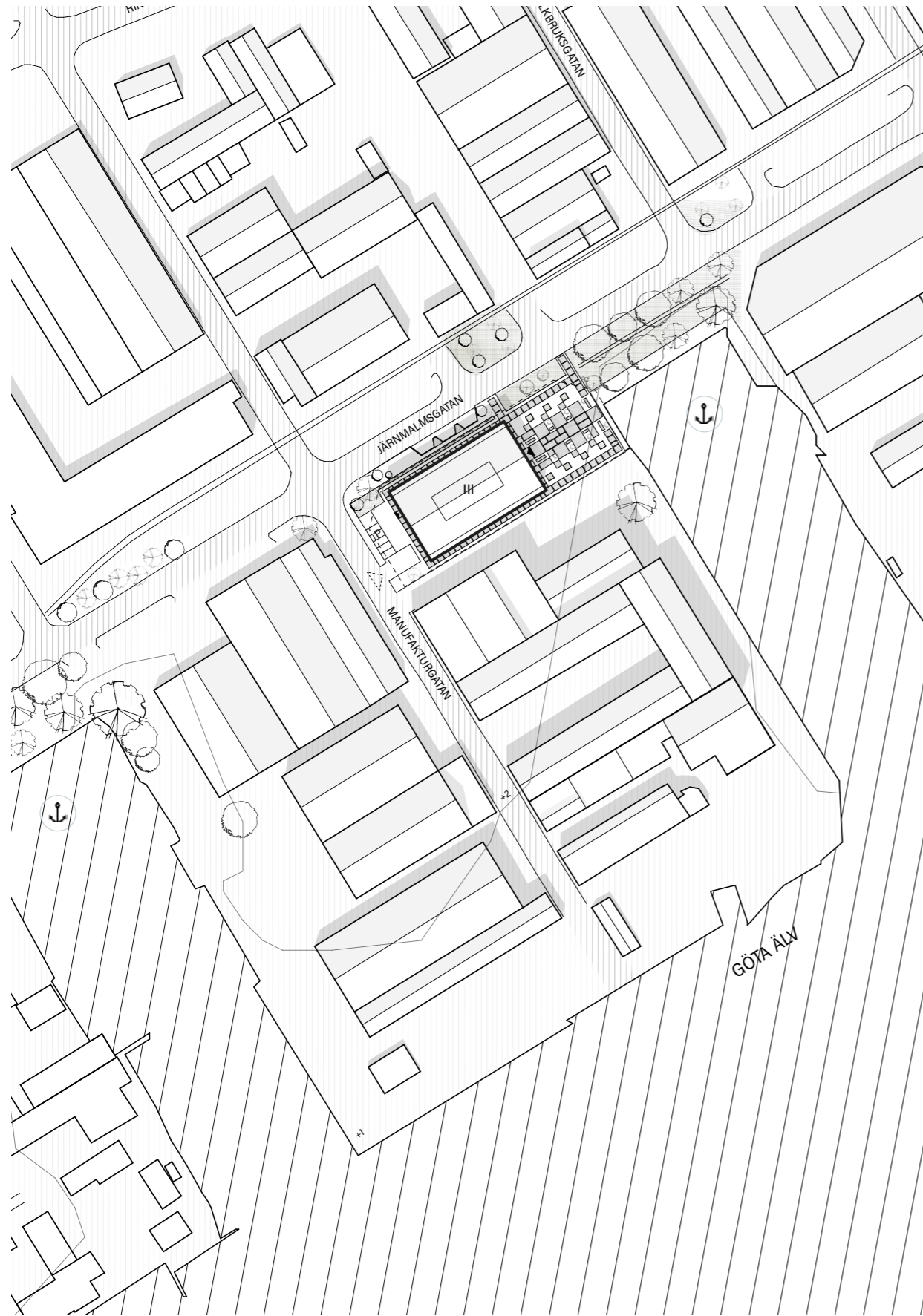

SITE OVERVIEW, SCALE 1 : 2 000



The project proposal - Balcony on the second floor, view towards the bar

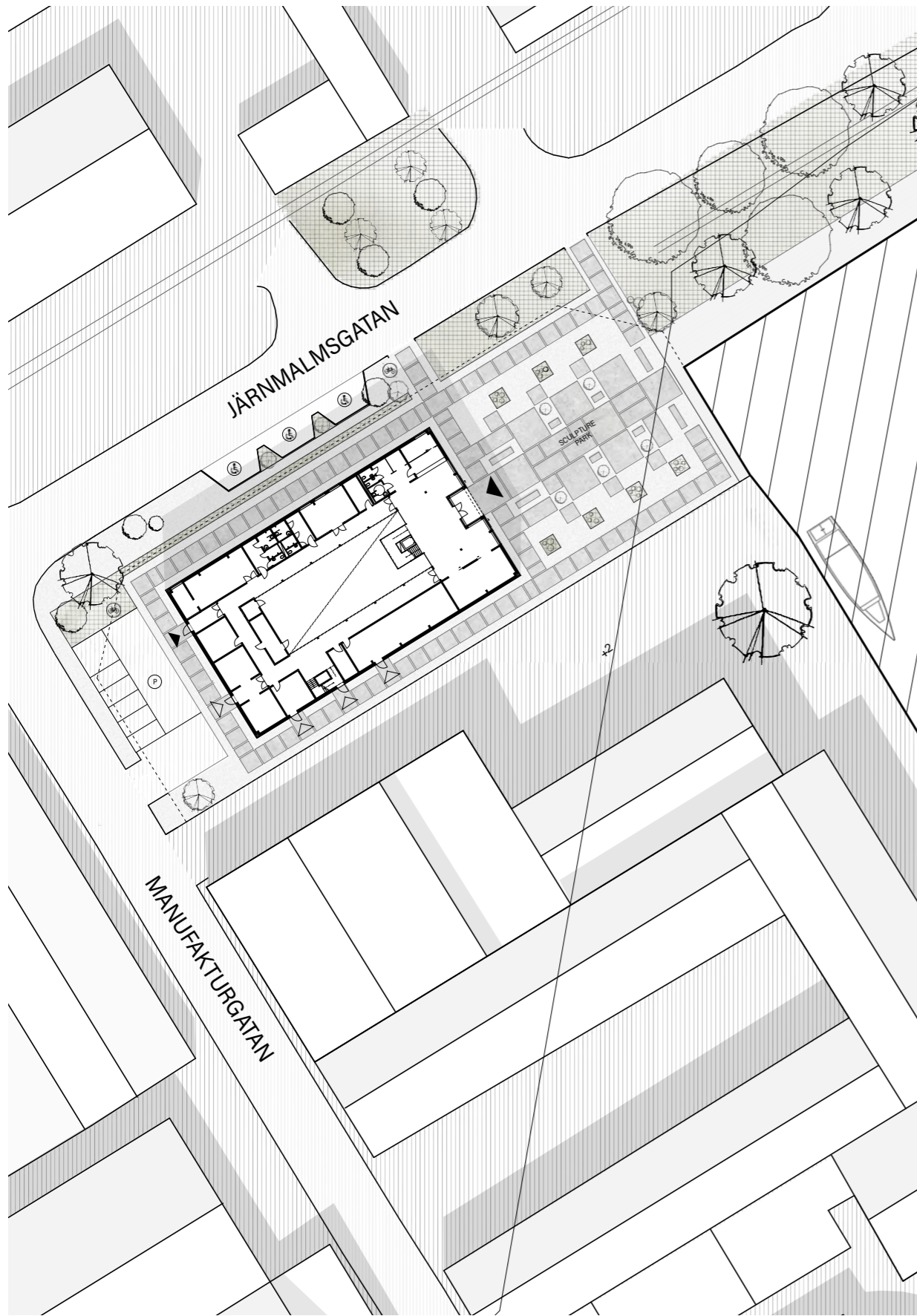

SITE PLAN, SCALE 1 : 800

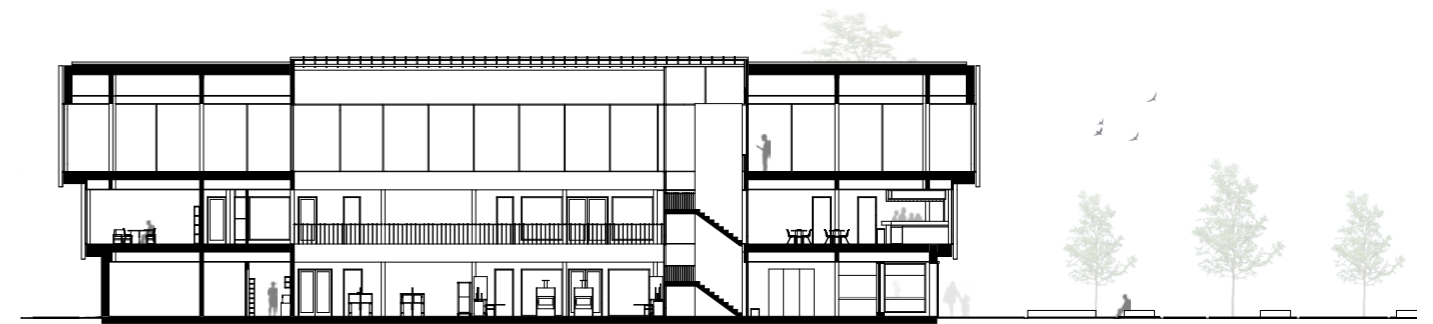

SECTION B-B, SCALE 1 : 400

PROGRAM

| FIRST FLOOR | SQM | | SQM |
|---------------------------|--------|--|----------------|
| 1. Main entrance | 13 | 16. Workshop | 114 |
| 2. Foyer | 121 | 17. Cold workshop | 45 |
| 3. Reception | 11 | 18. Technical workshop | 45 |
| 4. Office reception | 11 | 19. Tools & maintenance | 15 |
| 5. Wardrobe | 22 | 20. Office- workshop | 5 |
| 6. WC | 2 (3) | 21. Inventory glass/packaging store | 56 |
| 7. WC | 3 | 22. Stairs/lift (staff) & emergency exit | 22 |
| 8. Disabled toilet/shower | 5 (3) | 23. Inventory & load | 11 |
| 9. Store | 45 | 24. Storage | 23 (2) |
| 10. Stairs/lift (visitor) | 22 | 25. Cleaning storage | 10 |
| 11. Communication | - | 26. Fire riser room | 22 |
| 12. Entrance (staff) | 11 | 27. Electrical room | 10 |
| 13. Dressing room | 10 (2) | 28. Technical room | 78 |
| 14. Shower | 3 | 29. Garbage | 22 |
| 15. Lunch room | 33 | | |
| | | TOTAL FIRST FLOOR | 837 sqm |

| SECOND FLOOR | SQM | | SQM |
|---|--------|------------------------------|----------------|
| 30. Stairs/Lift (visitor) | 22 | 42. WC | 2 (4) |
| 31. Bar | 101 | 43. Shower | 2 (2) |
| 32. Lounge | 63 | 44. Lunch room | 41 |
| 33. Pre room WC | 12 | 45. Education/flexible space | 55 (2) |
| 34. Disabled toilet/shower | 5 (3) | 46. Studio (large) | 49 (2) |
| 35. WC | 2 (2) | 47. Studio (small) | 27 (2) |
| 36. Storage bar | 27 | 48. Office (large) | 27 |
| 37. Scullery bar | 21 | 49. Office (small) | 13 (2) |
| 38. Cleaning storage | 3 | 50. WC | 1 (2) |
| 39. Stairs/lift (staff), emergency exit | 27 | 51. Storage | 4 |
| 40. Communication | - | 52. Storage | 13 |
| 41. Dressing room | 13 (2) | 53. Storage studio | 13 |
| | | TOTAL SECOND FLOOR | 721 sqm |

| THIRD FLOOR | SQM | | SQM |
|---------------------------|-------|---|-----------------|
| 54. Stairs/Lift (visitor) | 22 | 58. Disabled toilet | 5 |
| 55. Exhibition space | 1028 | 59. Storage exhibition | 67 |
| 56. Pre room WC | 11 | 60. Stairs/lift (staff), emergency exit | 22 |
| 57. WC | 2 (2) | | |
| | | TOTAL THIRD FLOOR | 1159 sqm |

TOTAL 2717 sqm

(Communication not included)
Areas rounded to whole numbers

FIRST FLOOR

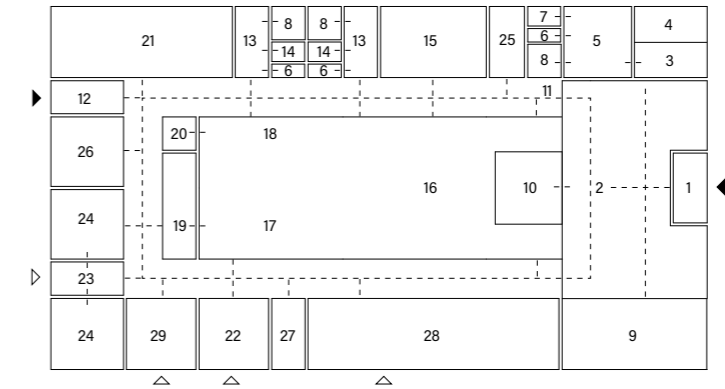

SECOND FLOOR

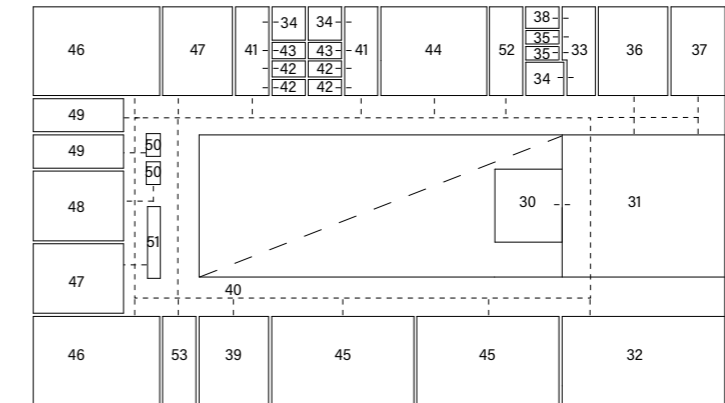

THIRD FLOOR

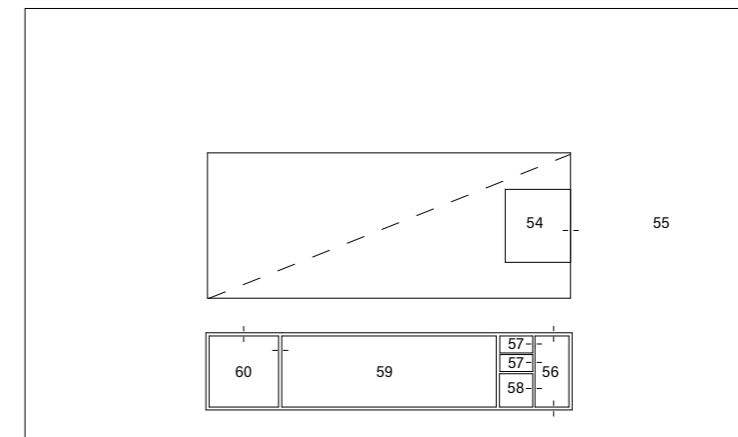

--- CONNECTION

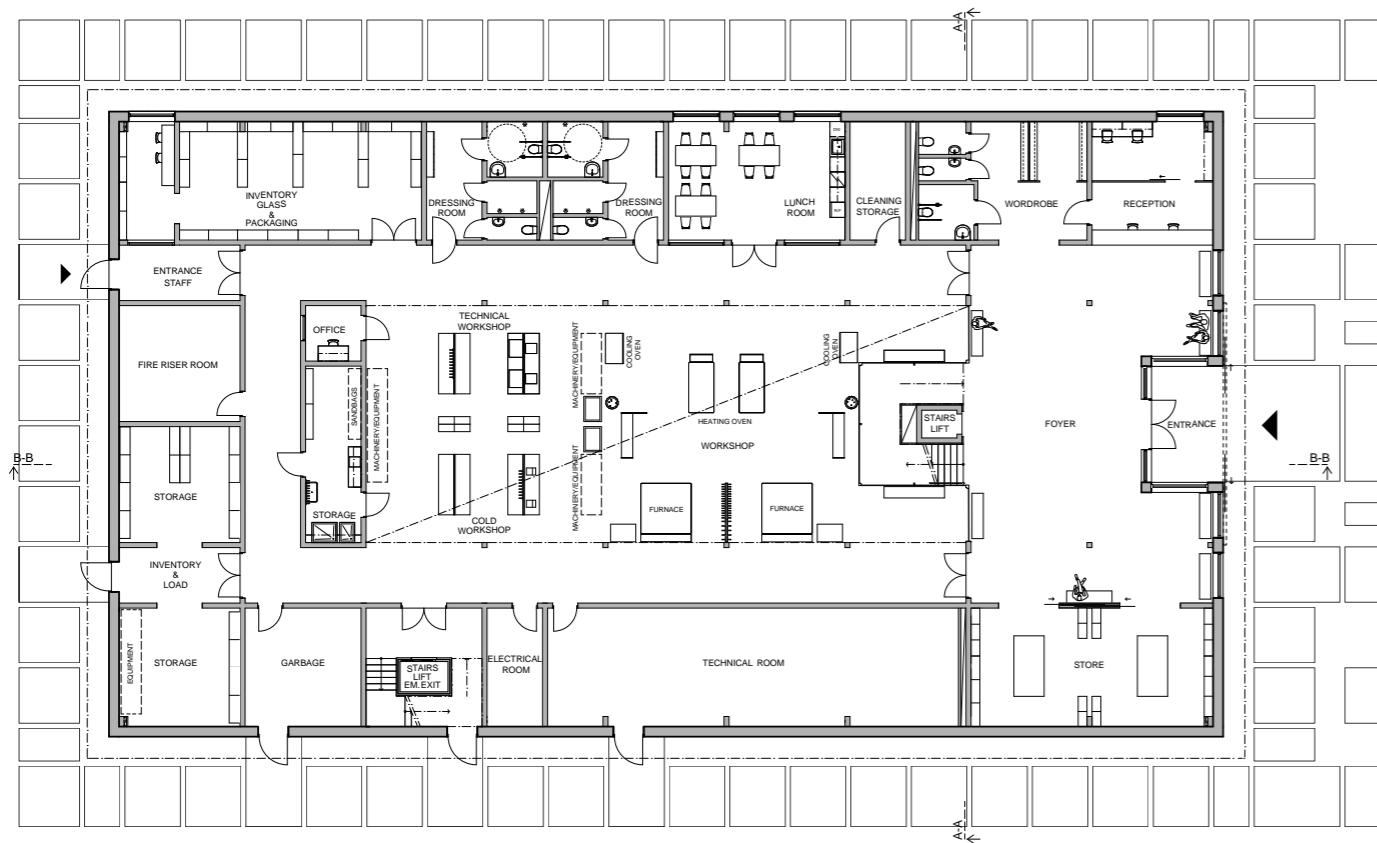

FIRST FLOOR, SCALE 1 : 300

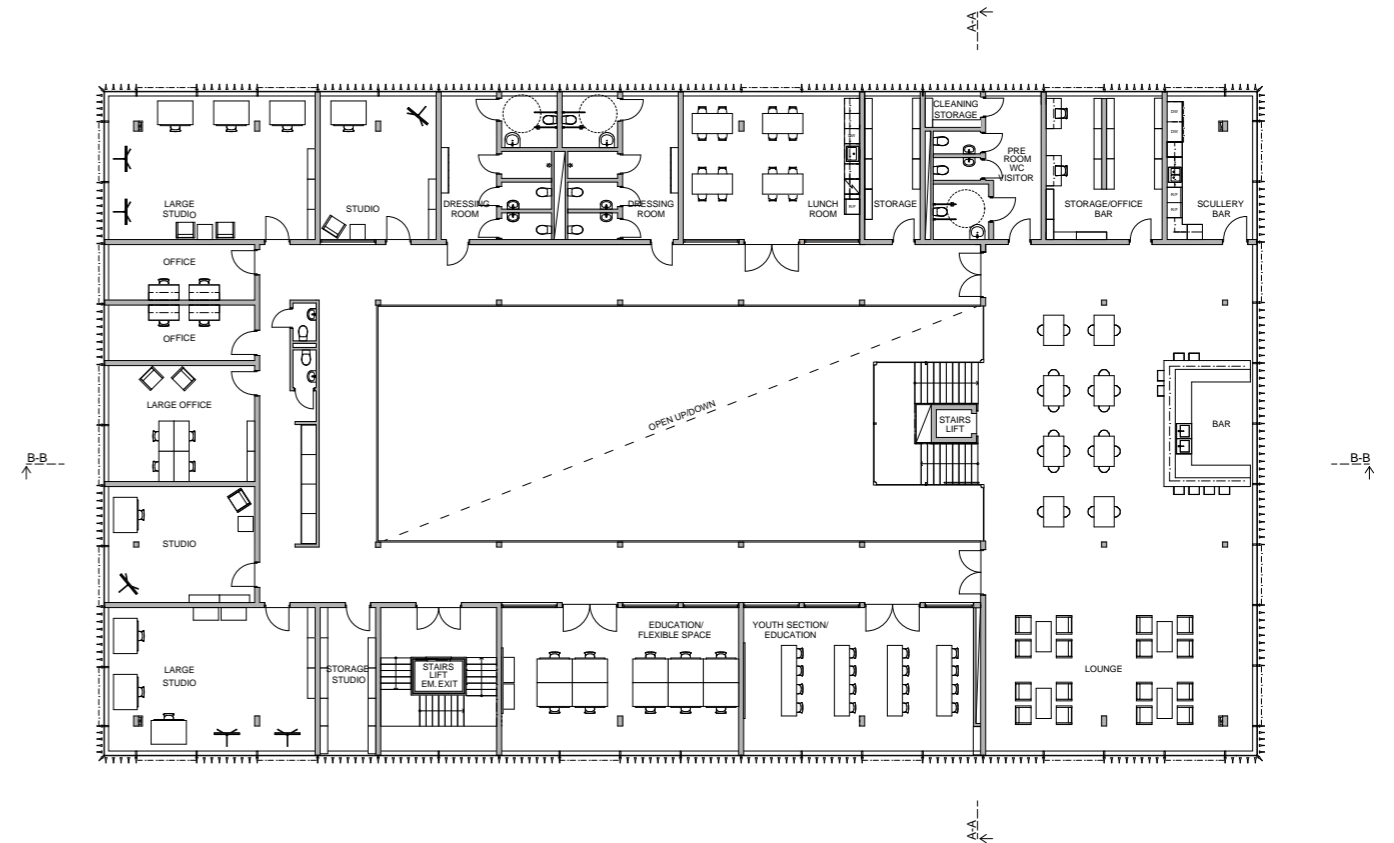

SECOND FLOOR, SCALE 1 : 300



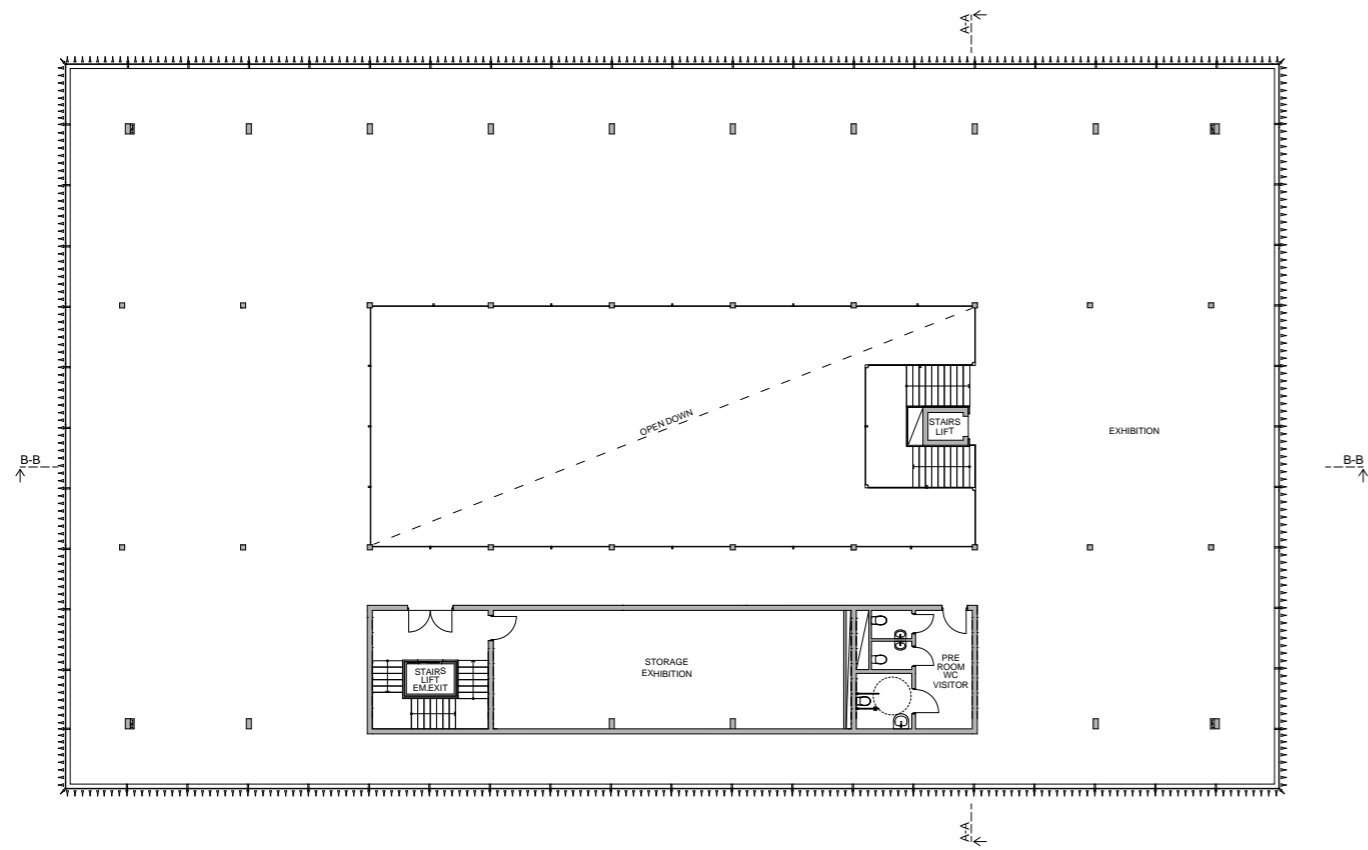

THIRD FLOOR, SCALE 1 : 300

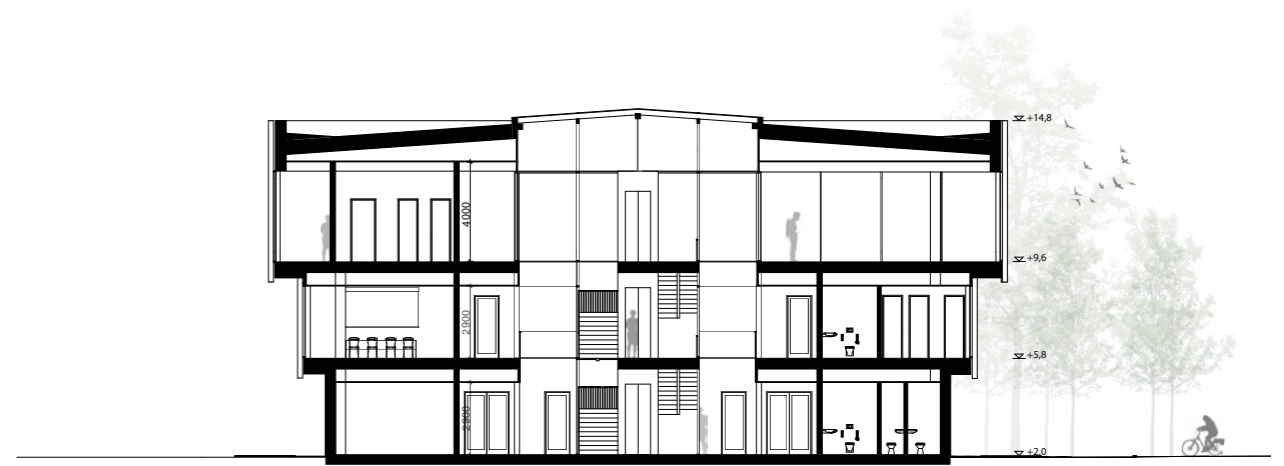

SECTION A-A, SCALE 1 : 300



ELEVATION - NORTHWEST, SCALE 1 : 300

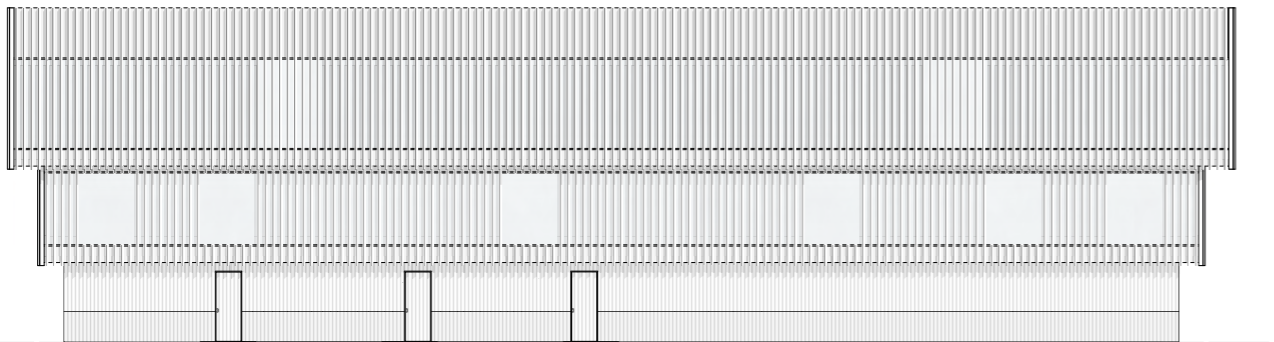

ELEVATION - SOUTHEAST, SCALE 1 : 300



The project proposal - The workshop

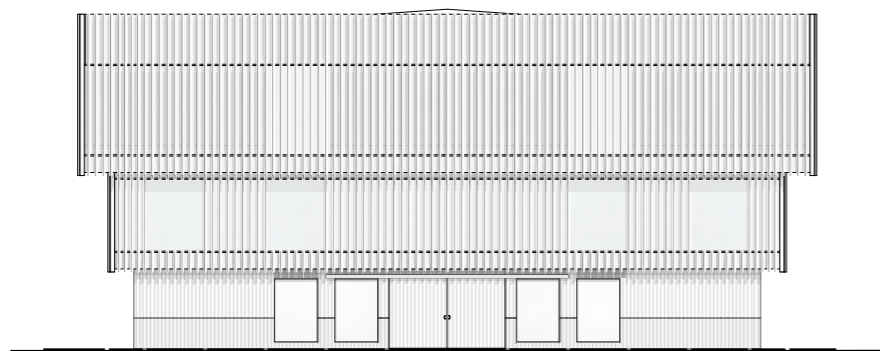

ELEVATION - NORTHEAST, SCALE 1 : 300

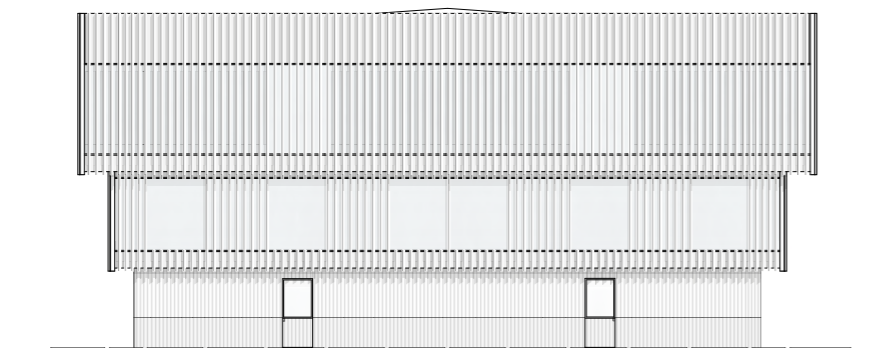

ELEVATION - SOUTHWEST, SCALE 1 : 300



The project proposal - The facade on the south-west gable



The project proposal - The bar with a view of the sculpture park



The project proposal - The reception

CONSTRUCTION AND DETAIL

The building's load-bearing system consists of a column and beam system of glulam, with a stabilizing joist layer of CLT-boards. The bottom slab is made of cast-in-place concrete and is piled, the other two floors, are built with CLT-boards, with hidden installations and a thin suspended ceiling of perforated wooden boards. The roof chair consists of a symmetrical double-pitched beam, which spans 28,8 meters and contributes to an open space on the third floor. To enable the cantilevering of the upper floors, these joists have been reinforced with an HSQ-beam. The pillar system is based on the basic grid of 1,2x1,2 meters, where the placement of the pillars spans between 4,8 meters in the longitudinal direction and 7,2 meters towards the center. To create an invisible meeting between the columns and the inner walls, the inner wall consists of CLT-panels of the same width as the columns, which also enables future reconstruction. To stagnate the volume, one of the walls by the emergency exit is used, as well as tension rods by the light yard near the staircase.

The outer wall is constructed as a curtain wall in two layers. The inner layer is built with wood, concrete, and glass, while the outer layer consists of vertical aluminum slats. The facade material on the first floor consists of an inner layer of prefabricated concrete, with an outer layer of cast-in-place concrete in a sine shape, as well as a sine-corrugated sheet of untreated zinc. As the zinc sheet ages, the surface gets a more matte finish and moves towards a lighter gray tone, which meets the concrete in a soft way. Around the roof as well as on the outside of the joists one will find a bent zinc sheet, where the bending is hidden behind the vertical details. The two upper levels have a suspended glass facade, where most of the glass panes on the third floor are frosted. Additionally, the curtain wall has been equipped with internal solar shading, which enables wider use of the spaces as well as the possibility to determine the amount of light admission. Furthermore, the aluminum slats act as sun protection and can be dismantled and reused. The vertical details also serve as a transition between the closed ground floor and the transparent upper floors. With the help of the vertical details, a lightness is given to the building, as well as contributing to a desire to discover its content.

Moreover, the roof consists of a low-sloping gable roof, which is hidden behind the facade. The roof's material consists of roofing felt, with solar panels in the south. The water from the roof is led down through downpipes that are placed inside the building, parallel to the pillars at the outer edges. The ground floor has only a few openings and faces inwards toward its activities. To enable a good amount of daylight and the possibility to ventilate excess heat from the workshop, part of the roof consists of a glass roof, with openable glass sections. The glass roof is constructed with a steel structure, connecting to the industrial character.

The facade materials are partly selected for their reusability and their possibility for recycling. Zinc as a material has a long durability with high recyclability, as does aluminum and glass. The prefabricated concrete can be reused, whereas the cast-in-place concrete can be recycled, for example, as filling material. The construction is made of wood, which was chosen due to its reduced climate footprint. To contribute to a more carbon-neutral environment, the roof is equipped with solar panels. The solar panels used in this project are manufactured in Sweden and receive a 90% lower carbon footprint compared to traditional solar panels (Midsummer, 2021). Depending on the geological conditions at the site, different geothermal energy sources can be used. By using the natural heat from the ground, energy consumption can be reduced and thus contribute to a more climate-friendly heating system. Furthermore, the wastewater can be used to reduce the total energy consumption, by installing a waste heat exchanger in the building. In addition, there is an opportunity to reuse waste and process heat from the furnaces in the glasswork. By making use of the waste heat from the electric ovens, the heating of the building can also be reduced.



The project proposal - Vertical details

CONCEPT
VERTICAL DETAIL

The vertical details take their inspiration from the sine-corrugated sheet metal, with a distance of 150 mm between each wave. The depth of each detail is about four times the depth of the sheet metal. To enable a view from the inside, the vertical details end up 300 mm from each other, with a few openings in the facade. Which gives the impression that every other sine wave is linear with the vertical detail.

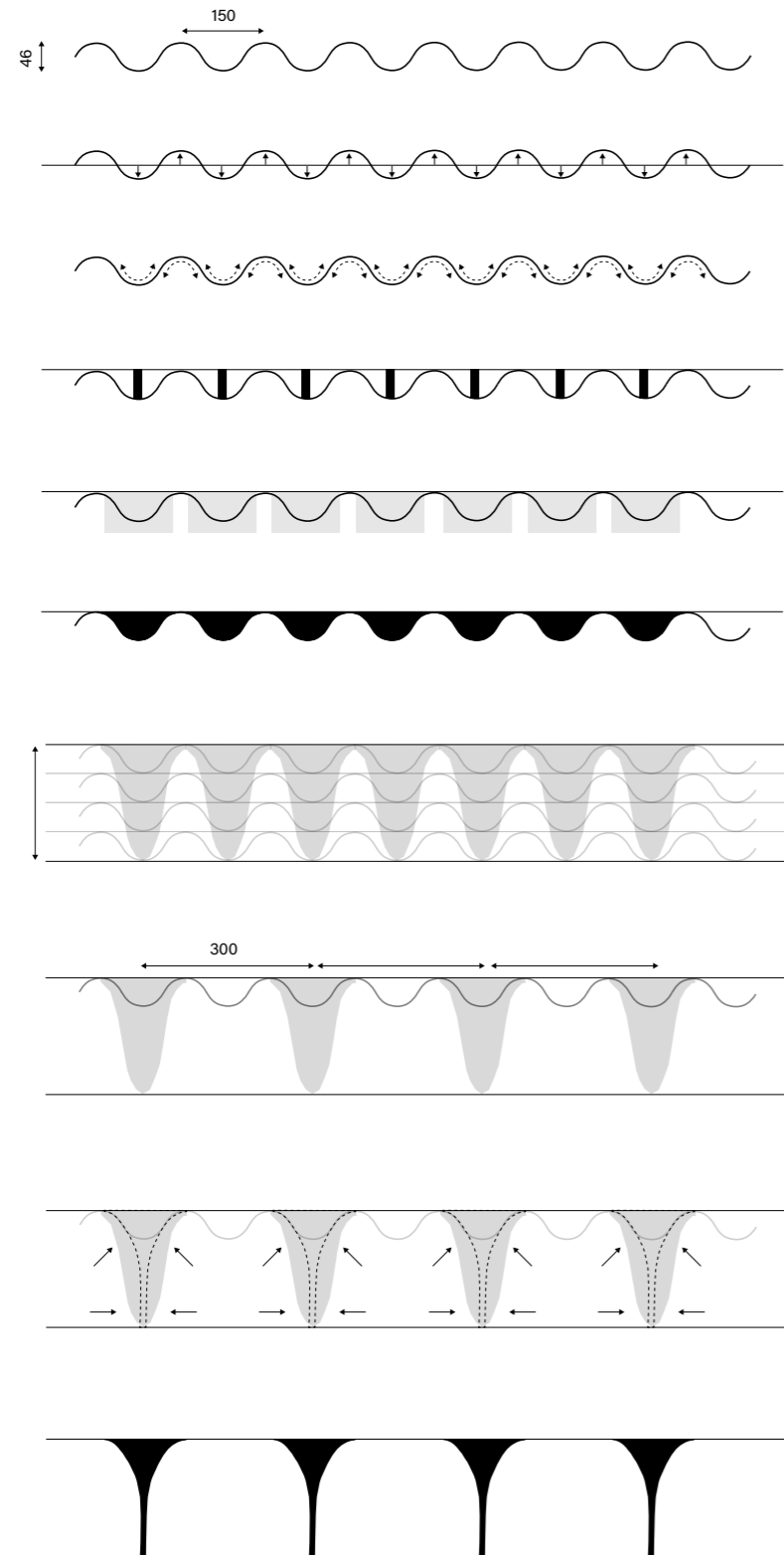

The project proposal - Physical model of the facade at ground level, scale 1.10

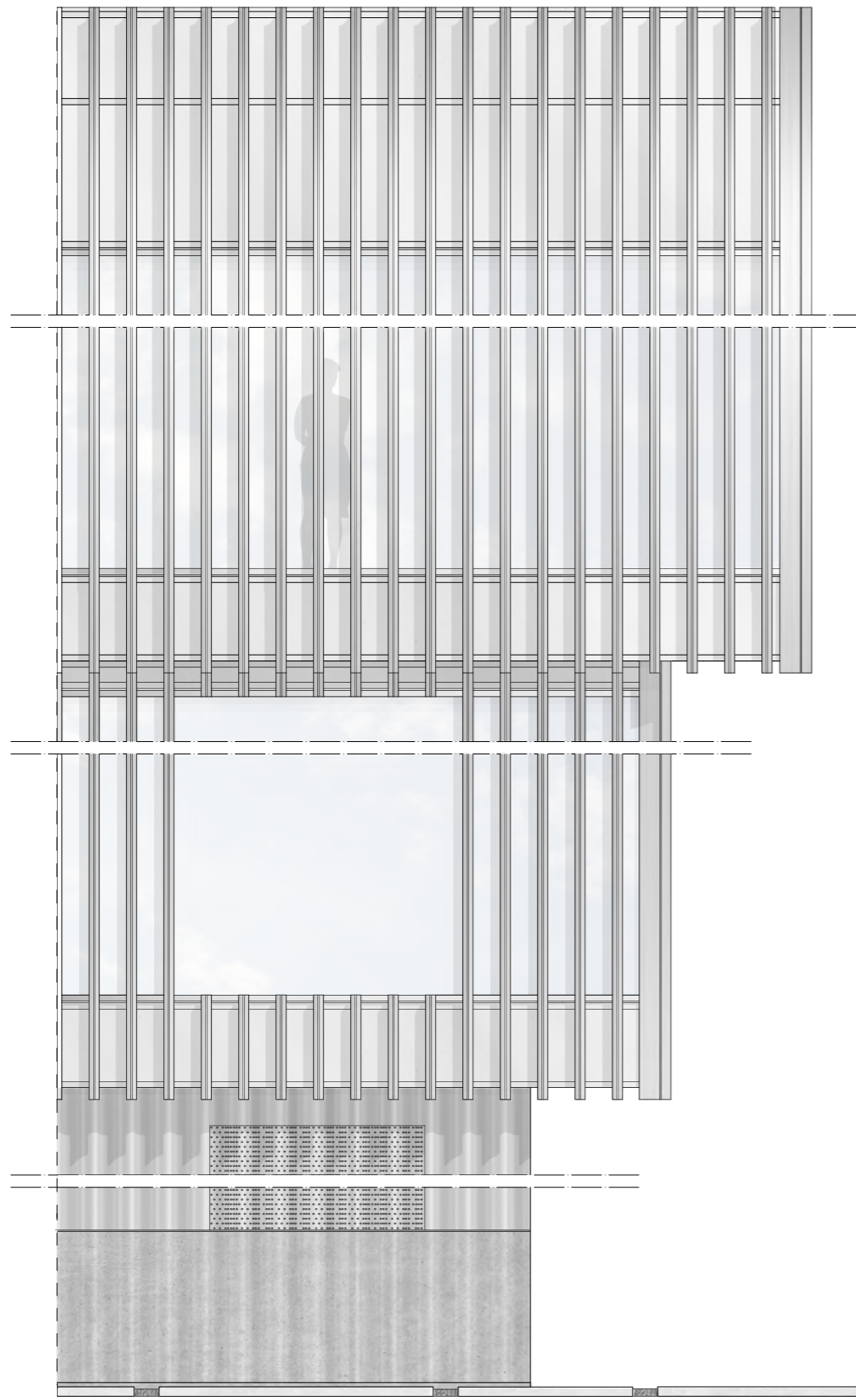

ELEVATION, SCALE 1:50

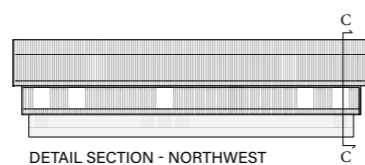

DETAIL SECTION - NORTHWEST

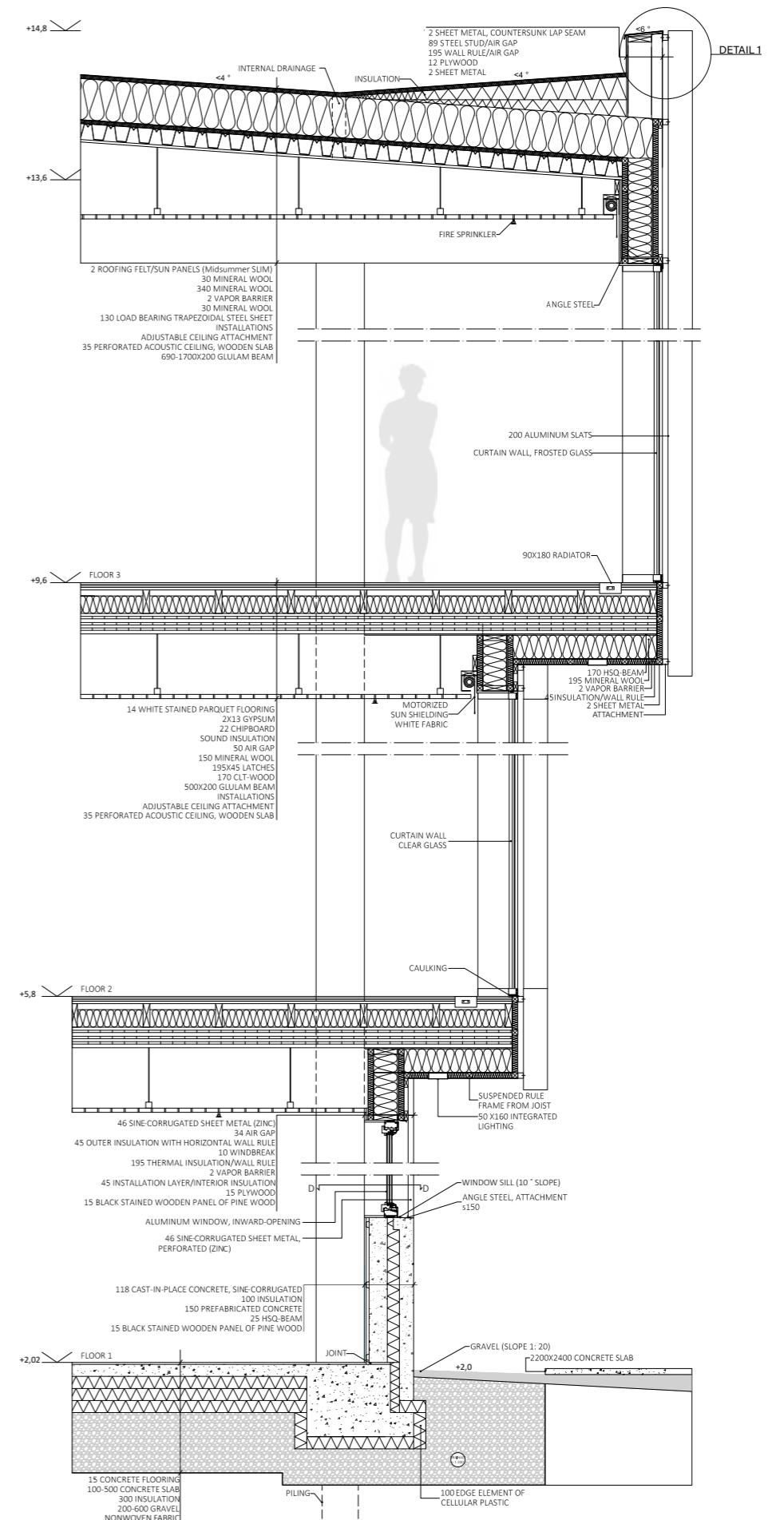

DETAIL SECTION C-C, SCALE 1:50

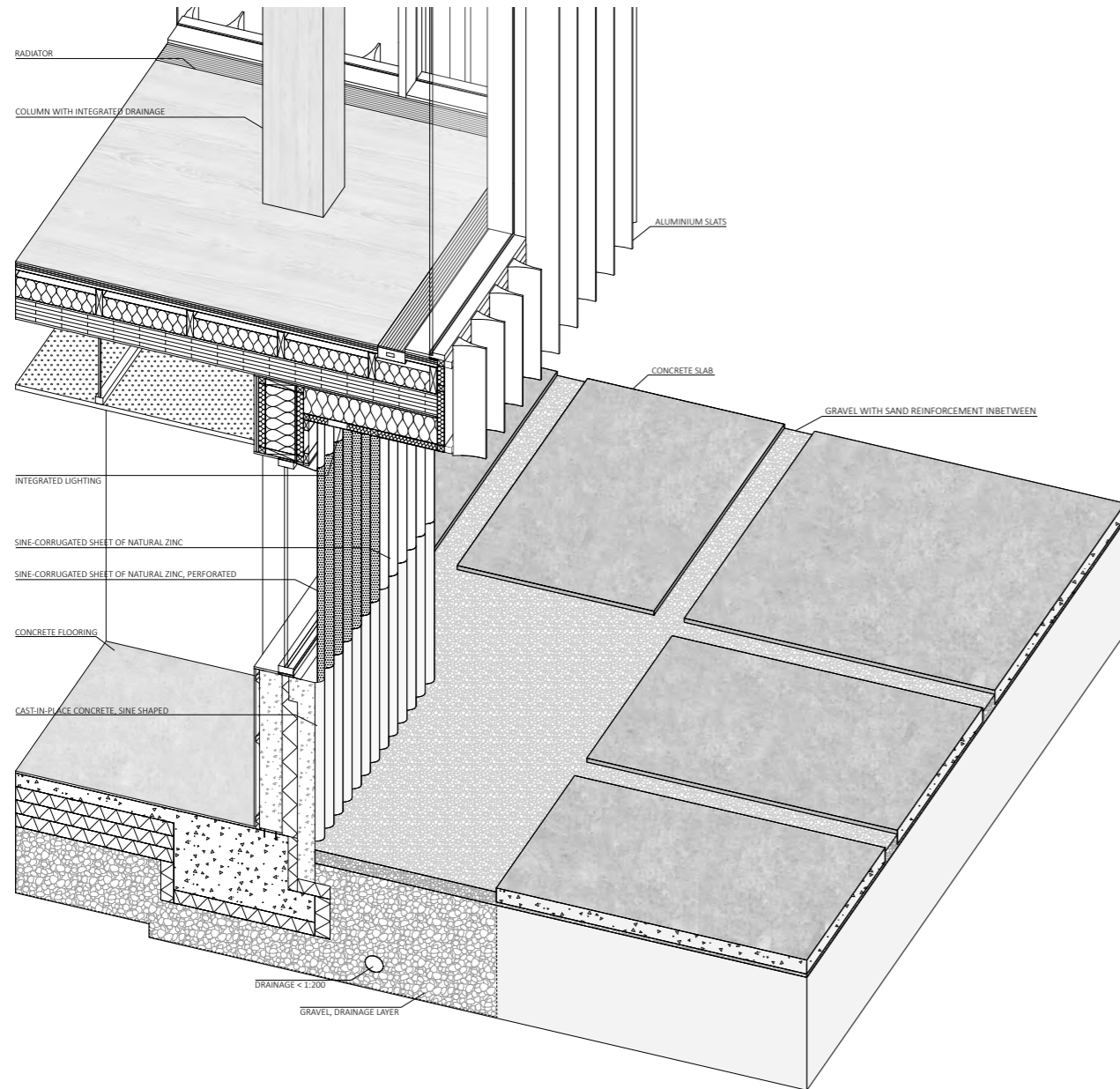

ISONOMETRIC DETAIL - FIRST FLOOR, SCALE 1:50

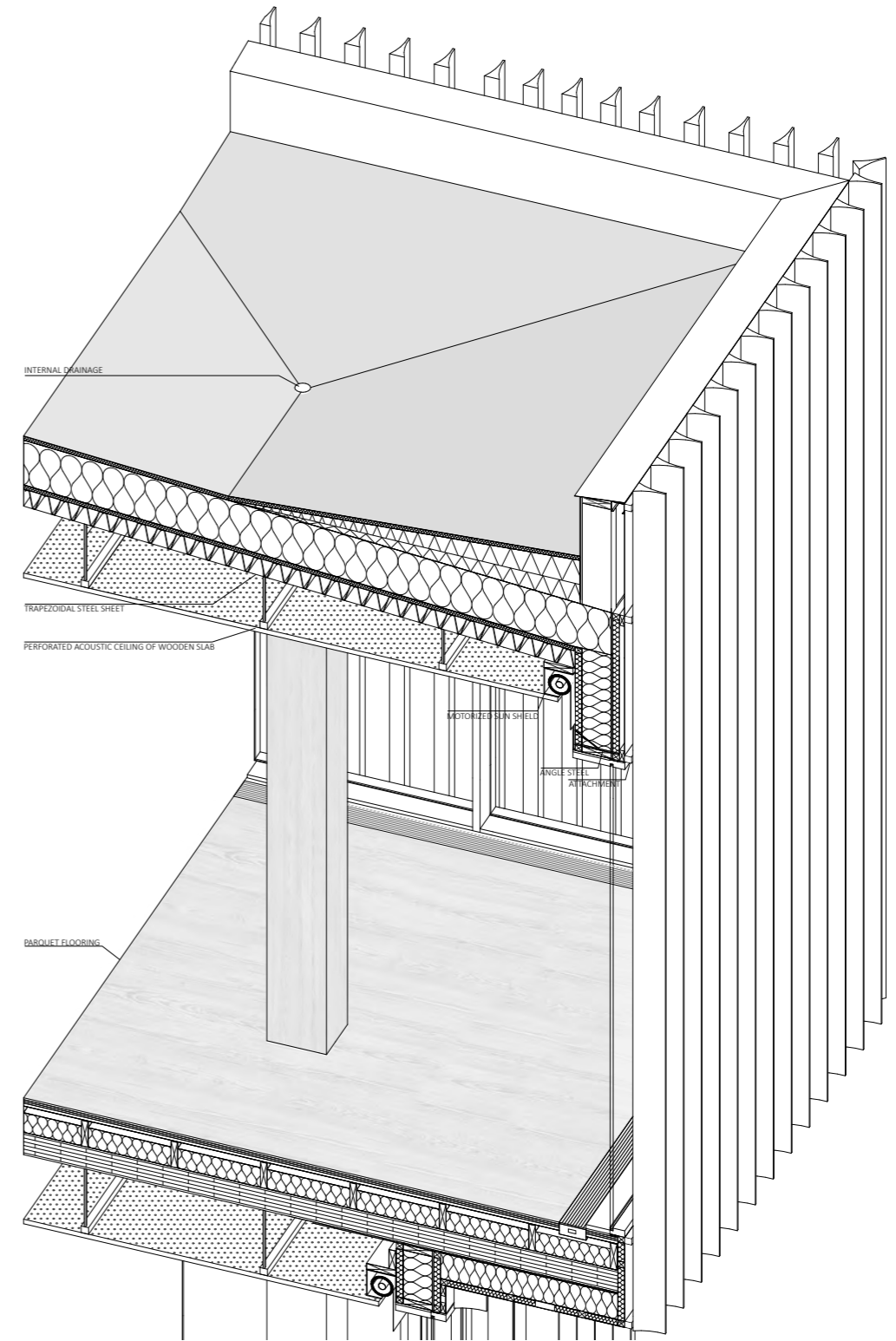

ISONOMETRIC DETAIL - THIRD FLOOR, SCALE 1:50

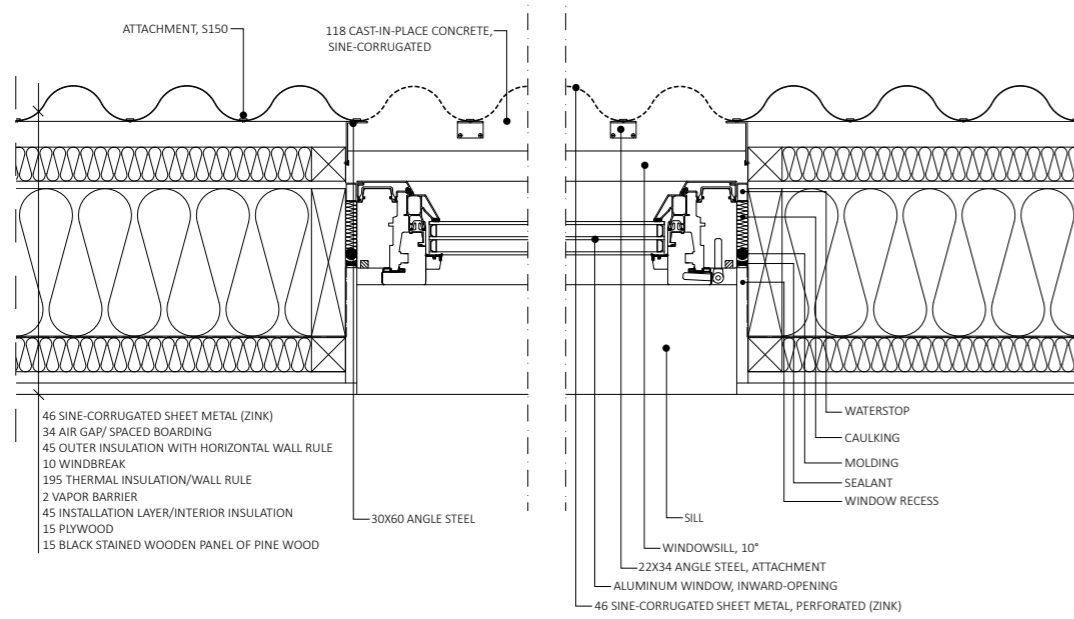

HORIZONTAL DETAIL D-D, SCALE 1:10

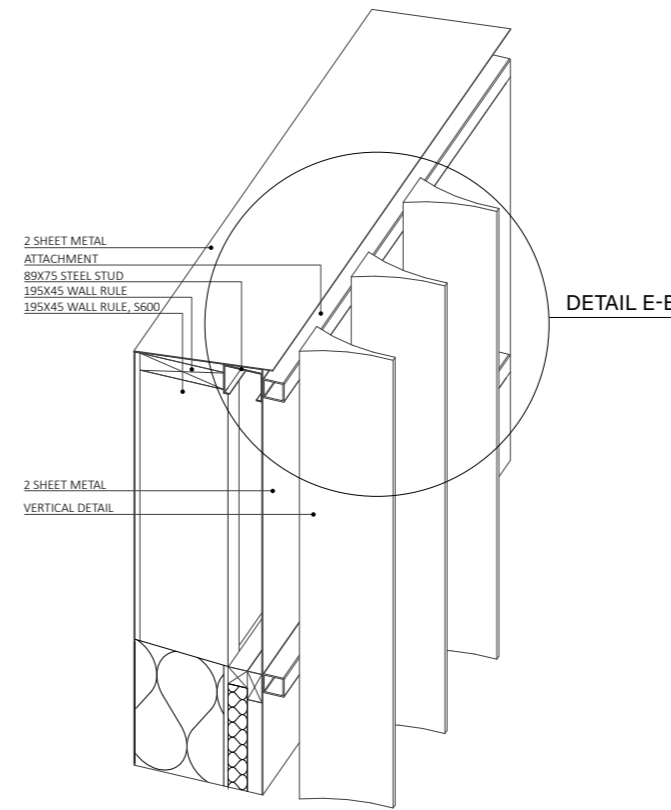

ISONOMETRIC DETAIL 1, VERTICAL DETAIL, SCALE 1:20

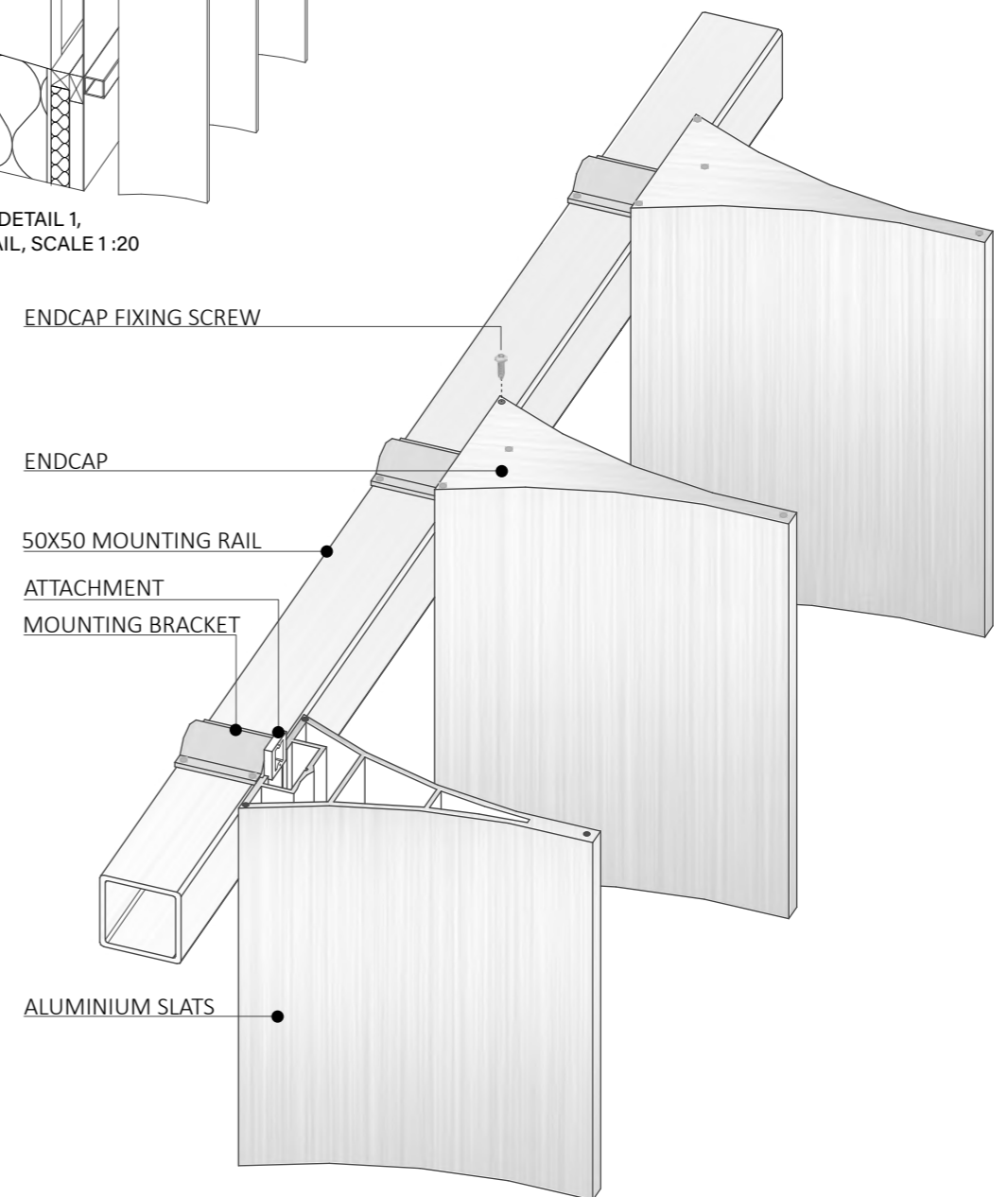

ISONOMETRIC DETAIL E-E - ATTACHMENT OF VERTICAL DETAIL, SCALE 1:5

CHAPTER 5
ANALYSIS
ARCHITECTURAL EXPERIENCE



The project proposal - Physical model, scale 1.50

ANALYSIS - ARCHITECTURAL EXPERIENCE

In the following part, three different room compositions are analyzed on the original floor plan, with the aim of answering the sub-question. The analysis is inspired by Kleine's theories from the book *The drama of space* (2018). First is the original layout presented, followed by *enfilade*, *visual continuum*, and finally *flowing space*. A principle followed is to enable movement around the light yard, regardless of the room composition.

ORIGINAL FLOOR PLAN

When the floor plan consists of the original layout, without adding exhibition walls, the direction of the movement is free. The movement found is around the light yard and the room volumes, which creates a circular movement. This type of directed movement Kleine (2018) describes as *body within space*. To orientate in the space, one can use the direction of the clear glass found in the facade, along the longitudinal direction, and on the gable sides. The advantage of the open floor plan is that the space can be used in several ways. On the other hand, is the architectural experience of the exhibition space more fragmented, where the exhibition has neither a clear beginning nor end.

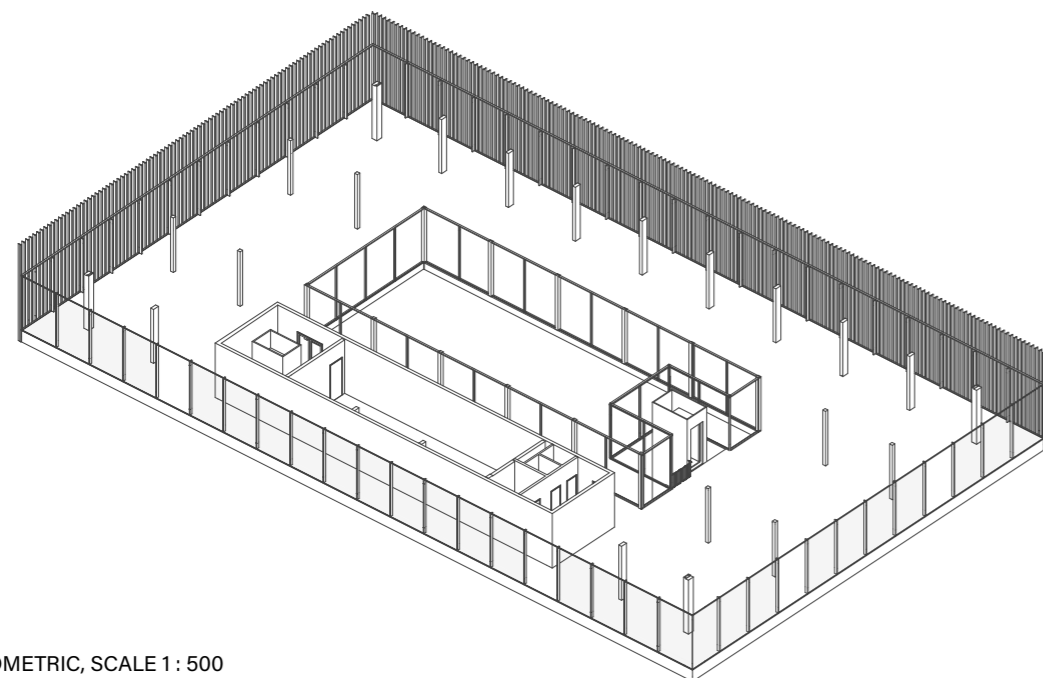
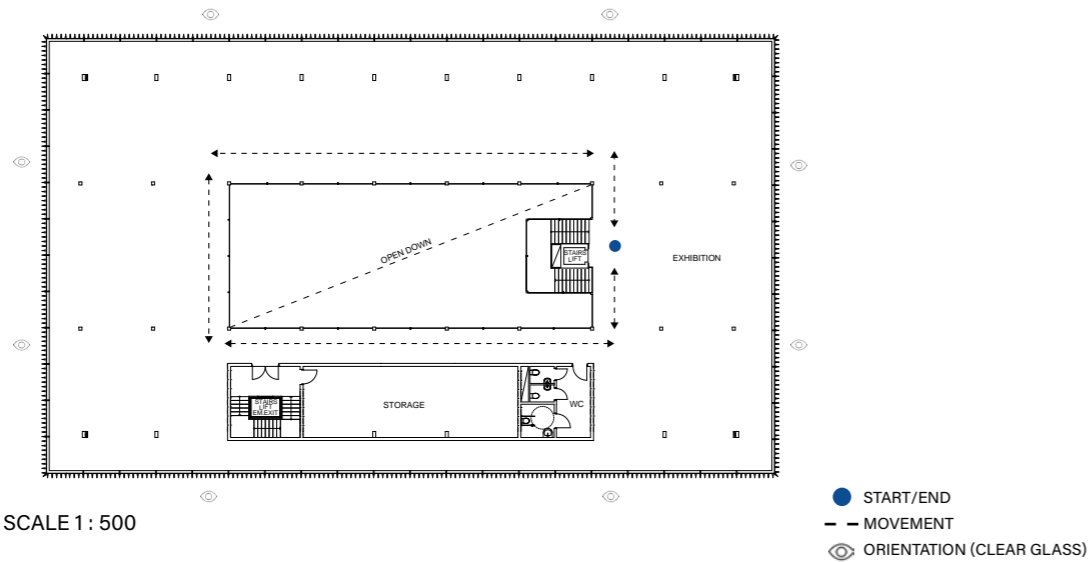

ENFILADE

According to Kleine (2018), is enfilade the simplest form of room composition. Here the dramaturgy takes place through sequences of spaces along a line. The rooms are announced one after the other in a linear development through openings. In this configuration, the wall is the dominant surface and where the opening has little impact on the atmosphere of the space.

By using the layout of the original plan as a basis, as well as following the principle of walking around the light yard, a variant of enfilade is created. Here the room composition consists of four different linear sequences, that work together. The architectural experience is relatively controlled, where the walls dominate, and the movement is linear. The clear glass openings in the facade do not have any effect here, the views rather become part of the exhibition.

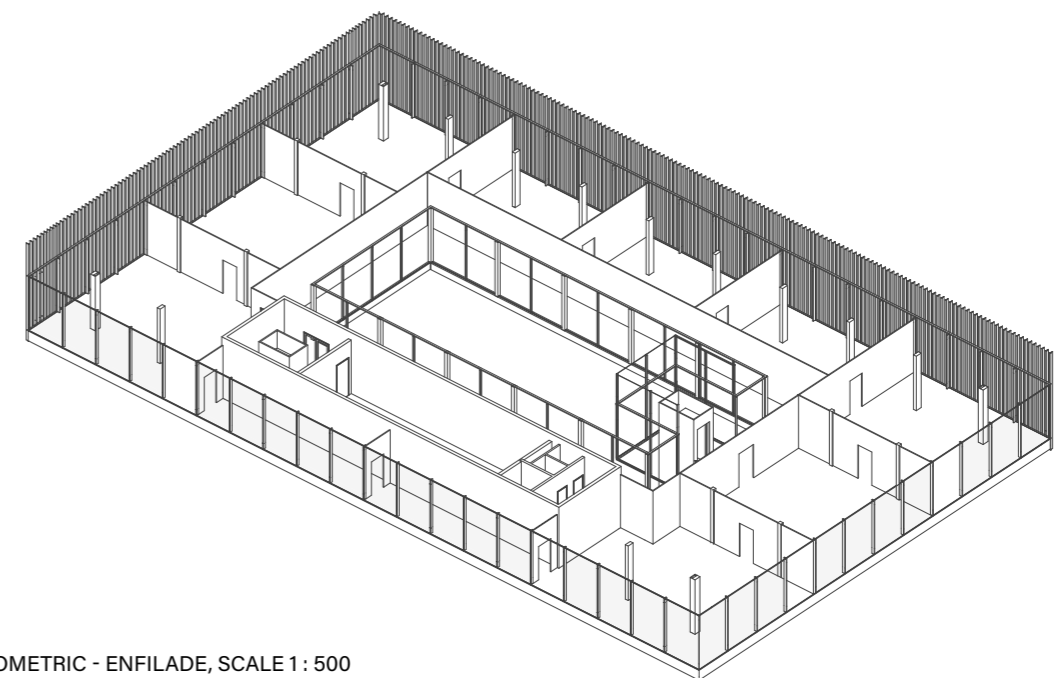
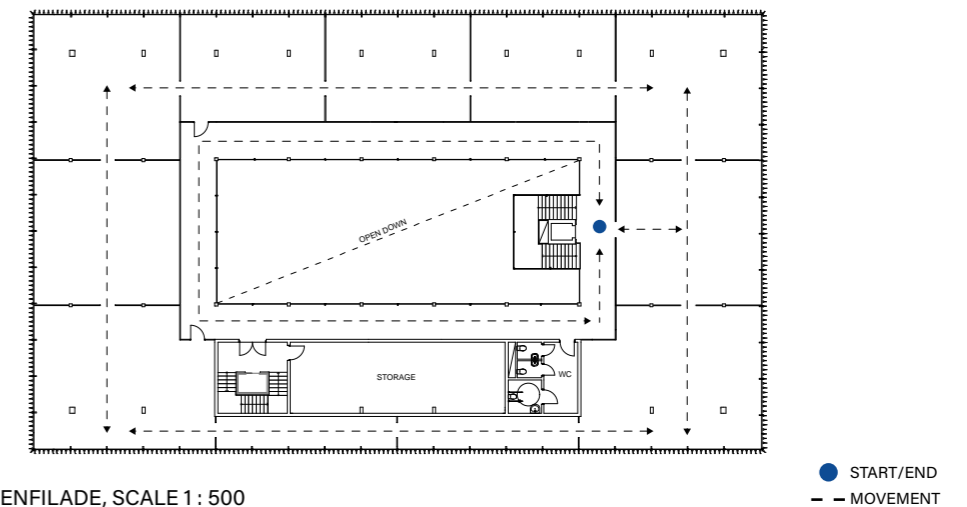

VISUAL CONTINUUM

Visual continuum can be described as simultaneity, unlike enfilade where the temporal experience is successive. To achieve visual continuum, the “fourth wall” is opened towards the adjacent room (Kleine, 2018). According to Kleine, the spaces are connected without physically intersecting and thereby influencing each other’s atmosphere. Here it is the opening that dominates the wall, but where even small openings can signal visual continuity. The greater the contrast between the surfaces, the more attention the space attracts says Kleine, which in turn affects our movement and architectural experience.

This room composition was more adapted to the original layout, with a more natural movement. In addition, there are further possibilities to divide the exhibition space. The architectural experience varies between being within smaller zones that flow into larger ones, where the connection between them flows together and defines each other. In addition, the light yard got a more obvious part of the exhibition. Finally, in this room composition, the clear glass contributes to direction and orientation of the space.

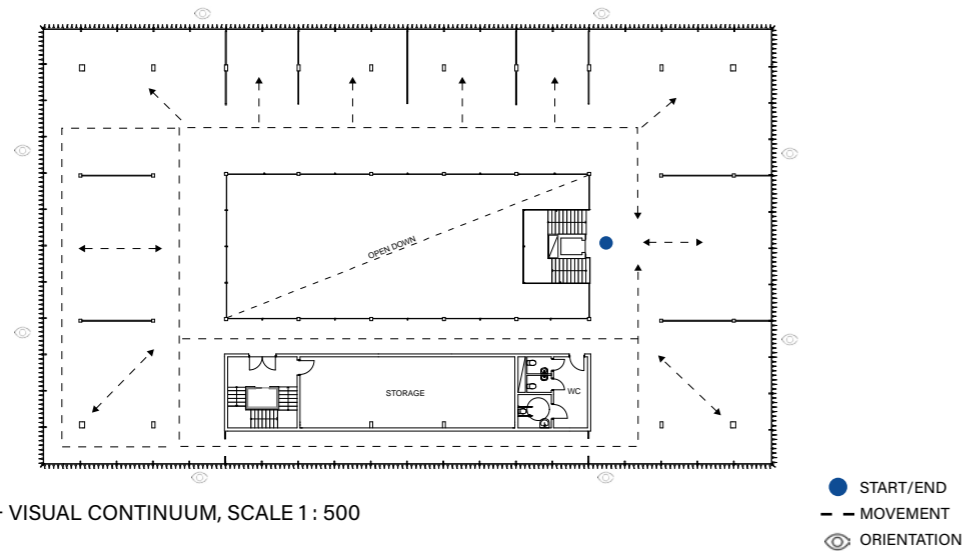

THIRD FLOOR - VISUAL CONTINUUM, SCALE 1 : 500

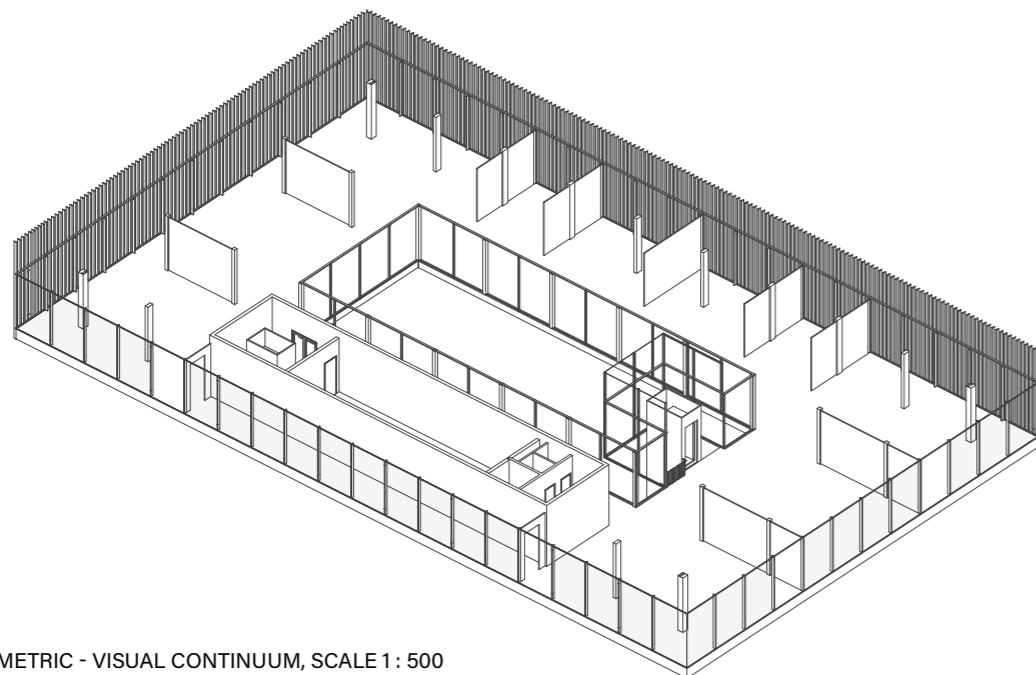

ISOMETRIC - VISUAL CONTINUUM, SCALE 1 : 500

FLOWING SPACE

Flowing space can be described as a seamless transition between different spaces, where the movement takes place freely between them (Kleine, 2018). As we move, the space we experience is constantly changing. Flowing space can look in several ways and consist of different types of “influencing elements”, such as guiding walls or rows of columns. According to Kleine, can this room composition be described as unclear, a spatial continuum, but which also contributes to a contemplative experience. Common archetypes within flowing space are mirrored and or adjacent walls, as well as angled and staggered walls that alternate in calm but irregular rhythms. Usually, narrow passages avoided.

This composition was well adapted, where several solutions were possible. The free-standing walls provide different experiences depending on the direction of movement. In addition, the clear glass could here function as a tool in reinforcing the direction of movement. The architectural experience can be described in different ways, where the viewer’s position is what determines the experience of the space. The advantage of flowing space is its flexibility and its relationship to the permanent parts of the building.

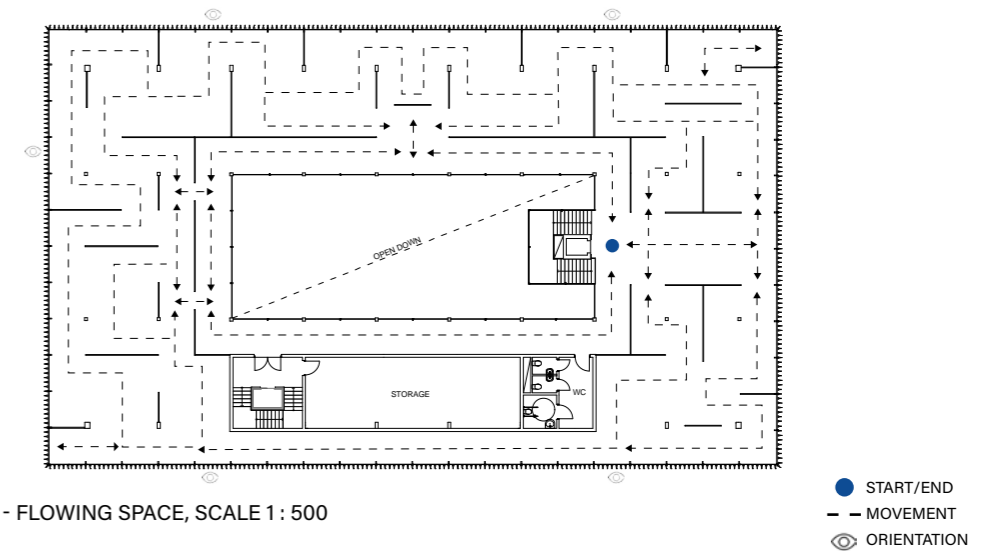

THIRD FLOOR - FLOWING SPACE, SCALE 1 : 500

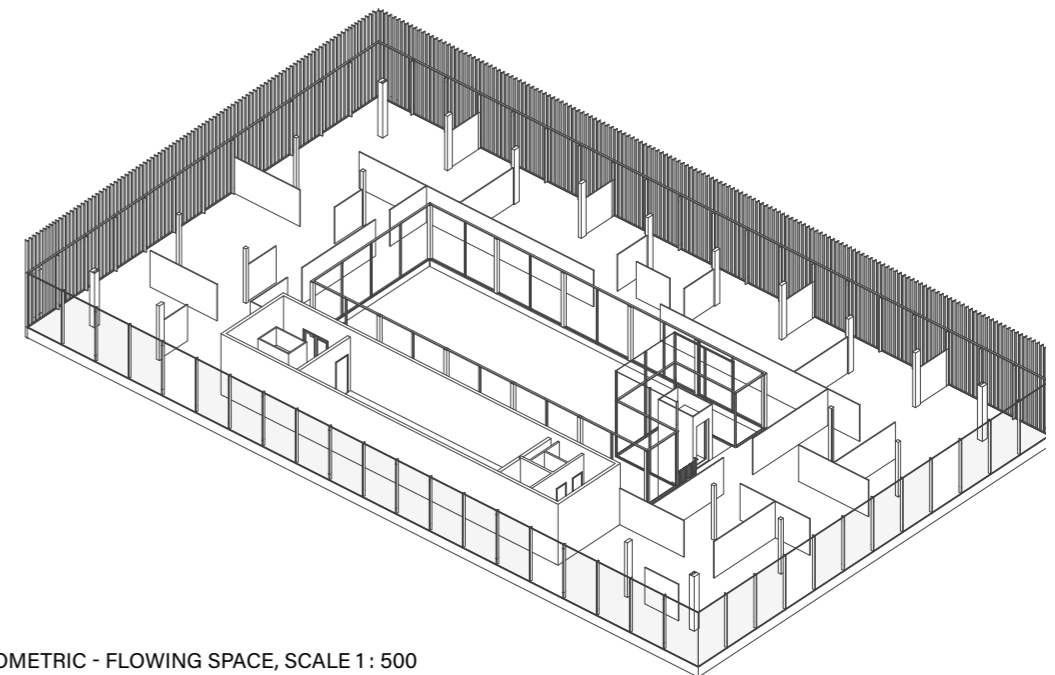

ISOMETRIC - FLOWING SPACE, SCALE 1 : 500

DISCUSSION

What makes a place, and what contributes to its identity? Ringön has a long and varied history, which arouses curiosity about architectural identity. By examining the area and its character and analyse the current activities that exist, as well as take part of Ringön's prospects, the idea of a new glasswork and exhibition center arose. A strong characteristic feature of Ringön is its production spirit, as well as its artistic and unique atmosphere. By adapting the content of the building to the the existing identity, a further development of the area's identity can be created, which in turn can strengthen the area's unique character. This idea, in turn, formulated the thesis' question, "*How can a modern glasswork and exhibition center be constructed with inspiration from the industrial character at Ringön?*". The sub-question, "*In what way can different room compositions vary the architectural experience of an exhibition space?*", arose during the investigation of the exhibition hall.

To answer the purpose of this thesis, built- and theoretical references have been used as a basis during the work, as well as analyses of the area and the City of Gothenburg's development plans for Ringön. A study visit to Skruf glasswork has been carried out, to create a greater understanding of what a glasswork is and how it works, as well as create a framework for the project proposal. Additionally, interviews with glass artists and people who are active in the development of Ringön have been carried out. Initially, the project started by visiting Ringön and identifying different characteristics of the area, inspired by the theories from the book *Learning from Las Vegas* (1972). The identified industrial character, in turn, created the framework around the building's size, orientation on the site, and the building's materials and construction.

The project proposal has intended to answer the thesis question, by using the characteristics of the area as inspiration. Where the project both strengthens and develops the area's identity. The cantilevered floors contribute to a new design element in the area and give the project proposal its own identity, inspired by the built reference, Pavilion Z (A8000, 2022). After an architectural observation of the area, various characteristic elements were listed, which inspired the design process. The building has a clean and simple volume, with a low-sloping roof, and large gates as the main entrance. The outdoor environment connects to the area's identity and frames the building's content. The first floor is more closed and focuses inwards, while the upper floors consist of a gradient of transparency. Here, the building's expression has been inspired by the area's high-set windows, with only a few openings at street level. The building's facade has been inspired by the area's materials, its vertical mounting, and its color palette. Around the ground floor, concrete and sine-corrugated zinc sheet are used to reinforce the character. The upper floors, on the other hand, receive a more modern expression. Where the facade consists of a suspended glass facade, with vertical aluminium details, which takes its inspiration from sine waves. In this way, an abstract connection is created between the first and the upper floors. Where the keyword has been, letting the old meet the new.

Moreover, the aim of the thesis has also been to create a deeper understanding of the movement and flow in a glasswork. Through a study visit and interviews, an additional framework was given. The framework of the glasswork contributed to the building's flow and movement, as well as the building's light yard, to accommodate good daylight, ceiling height, and the possibility of ventilating excess heat.

The sub-question have been investigated through theoretical references and an analysis of the proposed exhibition space. To create the prerequisites for an exhibition hall, where several scenarios could exist, the choice of construction was important. By working with a grid, with a column and beam system, freer surfaces were made possible, inspired by Leupen's *frame concept* (2006). Which contributed to the exhibition space being able to adapt to several room compositions of varying character. To reach an answer to the question, Kleine's theories from the book *The drama of space* (2018) were used as a basis in the analysis. It was an effective way to test different room compositions and see the differences between the various designs. Due to the scope of the thesis, the choice was made to only analyse architectural configurations consisting of walls. Because of this, only a limited answer is given to the question, which might have shown different results if other elements had been analysed as well. The first room composition, Enfilade, in my opinion, did not fit the layout of the exhibition space. The movement that was created became controlled and monotonous, and the architectural experience had to stand aside. Enfilade might have worked better if the light yard had not existed, or if the stairs had been placed elsewhere. Now a circular movement, which should be linear, was created. The second room composition, Visual continuum, was more adapted to the layout, where the light yard contributed an additional dimension of the space, with a more interesting architectural experience. Lastly, was an analysis of Flowing space performed. In my opinion was this room composition best suited for the exhibition space. Here, the architectural experience took center stage. Through the placement of the walls, the direction and movement could change, which created new experiences and room sequences. The advantage of flowing space was above all its flexibility and versatility.

In summary, the project has intended to answer, "*How can a modern glasswork and exhibition center be constructed with inspiration from the industrial character at Ringön?*" and "*In what way can different room compositions vary the architectural experience of an exhibition space?*". By identifying Ringön's character, a proposal was created that both shows inspiration, as well as contributes to an additional dimension in the area. It has been an interesting and difficult project, where the building's appearance and size have been examined from several angles, from detail to the whole. For further studies it would have been interesting to see how the project could have been developed over time, with a greater focus on changeability for future needs. In addition, conduct a deeper analysis of the built environment with a larger inventory, which could have contributed to other ideas about the buildings' design and layout. Furthermore, to summarize the result from the sub-question, the analysis showed that different room compositions can vary the architectural experience of the same space. From a repetitive architectural experience, to a more fragmented one, where the viewer's position and direction determine the experience. In addition, some of the room compositions were better suited in the original floor plan than others, which may have contributed to the results. Moreover, it would have been interesting to conduct further studies on the room compositions' impact on space, as well as a study on how objects, colors, and other elements could have further enhanced the architectural experience. Additionally, it would have been interesting to see how the analyses would have changed if the building's main staircase had been moved, and or if the light yard had existed in a different size or shape.

Finally, being inspired by our surrounding environment, as a way to strengthen the city's identity, is what I believe contributes to a more diverse and sustainable city. Because what would we be without our history.

REFERENCE LIST

ARTICLES AND PUBLICATIONS

Business Region Göteborg. (2022). Saltet, *Tillåtande Miljöer*. (Pp. 47-49).

Nylander, O. (January 1, 2017). "Kanal som gjorde Ringön till en ö." *Göteborgs-Posten*. <https://www.gp.se/kultur/kultur/kanalen-som-gjorde-ring%C3%B6n-till-en-%C3%B6-1.4135121>.

BOOKS

Ballard Bell V., & Rand P. (2006). *Materials for architectural design*. Princeton Architectural Press, New York.

Kleine, H. (2018). *The Drama of Space – Spatial Sequences and Compositions in Architecture*. (Transl. Julian Reisenberger). Basel: Birkhauser

Leupen, B. (2006). *Frame and generic space*. 010 Publishers. Rotterdam.

Venturi R., Scott Brown D. & Izenour S. (1972). *Learning from Las Vegas*. MIT press.

WEBB

A8000. (January 7, 2022). "Exhibition centre Pavilon Z / A8000." ArchDaily. Accessed: 2023-01-15, at <https://www.archdaily.com/974697/exhibition-centre-pavilon-z-a8000>.

Griffiths, A. (November 12, 2017). "Vitsø completes "intentionally unfinished" cross-laminated-timber headquarters". Dezeen. Accessed: 2022-11-27, at <https://www.dezeen.com/2017/11/12/vitsoe-intentionally-unfinished-cross-laminated-timber-headquarters-england-uk-architecture/>

Hallgruppen. (n.d.). *Industri & produktion*. Hallgruppen. Accessed: 2023-04-27, at <https://hallgruppen.se/bransch/industri-produktion/>

Midsummer. (2021). *Midsummer SLIM*. Midsummer. Accessed: 2023-04-26, at <https://midsummer.se/midsummer-slim/>

Northpower. (2023). *Travershall*. Northpower. Accessed: 2023-04-26, at <https://www.northpower.se/stal/standardhallar/travershallen/>

SBI, Stålbyggnadsinstitutet. (2023). *Hallar och industrier*. SBI. Accessed: 2023-04-26, at <https://www.sbi.se/hallar-och-industrier/>

Skatteverket. (August 27, 2021). *Skatteverkets allmänna råd (SKV A 2021:24)*. Skatteverket. Accessed: 2023-04-27, at https://www4.skatteverket.se/download/18.50e9db3181d0f003602224/1661174836663/SKV%20A%202021_24.pdf

SKRUF. (2023). *Om Skruf's glasbruk*. SKRUF. Accessed: 2023-01-27, at <https://skrufsglasbruk.se/om-skrufs-glasbruk/>

The Glassery. (2022a). *Glasets historia i Sverige*. Accessed: 2022-10-12, at <http://theglassery.se/>

The Glassery. (2022b). *Glasbruk i Sverige*. Accessed: 2022-10-12, at <http://theglassery.se/>

The Glassery. (2022c). *Vad är glas?* Accessed: 2022-10-12, at <http://theglassery.se/>

The Glassery. (2022d). *Olika tekniker för konstglas*. Accessed: 2022-10-12, at <http://theglassery.se/>

ACKNOWLEDGEMENT

A special thank you to all of you who have supported and helped me during this process!

Björn Gross

Mikael Ekegren

Emil Göransson

Peter Lindblom

Per Lundström

Tabita Nillson

Kent Elm

Skruf glasswork

Juha Rosenström

Jonas Hermansson

Helena Gibson

Åsa Hüffmeier

Robert Eriksson

Johan "Red Top" Larsson

Friends and family

