

R
O
B
U
S
T

Gustav Kristensson

Master's Thesis in Architecture 2024

DESIGN WITH WOOD

- A case study of a new office building in *Nya Varvet*, Gothenburg

ROBUST DESIGN WITH WOOD

- A case study of a new office building in *Nya Varvet*, Gothenburg

Master's thesis 2024

Building Design and Transformation

Chalmers Technical University

Department of Architecture & Civil Engineering

Architecture and Urban Design

Supervisor: Filip Rem

Examiner: Björn Gross



Gustav Kristensson



Abstract

The usage of wood in buildings is a very old practice but it is still developing. This master's thesis investigates the usage of wood as both construction material and design material to achieve a robust design. Five main subjects are investigated in the context of robustness: Construction, fire resistance, indoor climate, noise reduction and maintenance.

The investigation is made through a case study in the context of a new office building for the client Northern Offshore Services. NOS is a company in need of a new office building and a warehouse and aims for robustness being the identity of the project. The case study is located on a site next to the water in "Nya Varvet" in Gothenburg.

This master's thesis arrives in a proposal of a new office building and a new warehouse using wood both as construction material and design material. The wood is used both exteriorly and interiorly. Solving challenges both in the design of a good office environment but also focusing on creating a robust building.

Student background

	Gustav Andreas Micheal Kristensson
2019 - 2022	Bachelor's degree, Architecture Chalmers University
2022 - 2024	Master's degree, Architecture and Urban Design Chalmers University
	Studio fall term 2022: <i>ARK263 Future visions for healthcare, housing and work 3: Healthcare Architecture</i>
	Studio spring term 2023: <i>ARK137 Future visions for healthcare, housing and work 2: Housing Inventions</i>
	Studio fall term 2023: <i>ACE515 Building Tectonics 2</i>
2021 - 2024	Parallel to education, employment at Design + Development

Table of content

Introduction	8
Aim	8
Thesis question	8
Delimitation	9
Keywords	9
Method	10
Background	13
Theory	14
References	20
Context	22
The client	24
Project ambition	24
Brief	26
The site	28
Proposal	32
The site	36
Adaptability	38
Floor plans	42
Sections	52
Elevations	54
Construction	58
Detailed elevation and section	60
Noise reduction	64
Indoor climate	65
Maintenance	66
Fire resistance	67
The warehouse	68
Discussion	70
Reference list	74
Special thanks	76

Aim

This master's thesis will investigate how to solve different challenges that may occur by using wood in construction and design to develop knowledge of the strengths and weaknesses of using wood. The different challenges can be categorized as construction, fire resistance, indoor climate, noise reduction and maintenance. Solutions to these challenges will be investigated in the context of robustness. The goal of this master's thesis is to determine which method is best suitable for generating a robust design to help future architectural building projects achieve robustness in buildings with the usage of wood.

The investigation will be produced through the context of a case study of a new office building in "Nya Varvet" Gothenburg.

Thesis question

How can a robust design be achieved with wood as construction and design material?

Delimitations

The main material used in this study will be wood and timber. The usage of other material is not forbidden but limited to good reasons behind the usage.

When wood is referenced as a building material it is often used in the context of sustainability. Even though the connection between sustainability and wood will be mentioned in this master's thesis it is not the purpose of the project to deeply study how the usage of wood contributes to lower the climate impact compared to the usage of traditional materials.

Keywords

Robust design, tectonics, constructions, fire resistance, indoor climate, noise reduction and maintenance.

Method

This master's thesis will utilize the methods of research by design. Using the case study as a foundation and a goal in designing. The designing different iterations to achieve the brief in relation to robustness and wood. Using the design as a way to increase knowledge and understanding of how to achieve the purpose.

The methods used in this master's thesis is a common strategy in today's architectural practice which focuses on solving challenges as they arrive. In this master's thesis the main challenges are connected to the five main subjects, Constructions, Fire resistance, Indoor climate, Noise reduction and Maintenance. The methods to solving these challenges that occurs is to look for solutions in different places. This thesis will research solutions through three main ways:

References:

Researching how other projects have solved similar challenges. Gaining knowledge and inspiration from analyzing already built projects.

Experts:

Discussions and interviews with people of professions connected to the challenges. Gaining knowledge on different solutions.

Literature:

Researching studies and literature both scientific and profession based. Gaining knowledge about materials can and are used to solve different solutions.

The next step is to evaluate the different solutions and moving forward with the one best connected to this thesis main subject, robustness with wood.

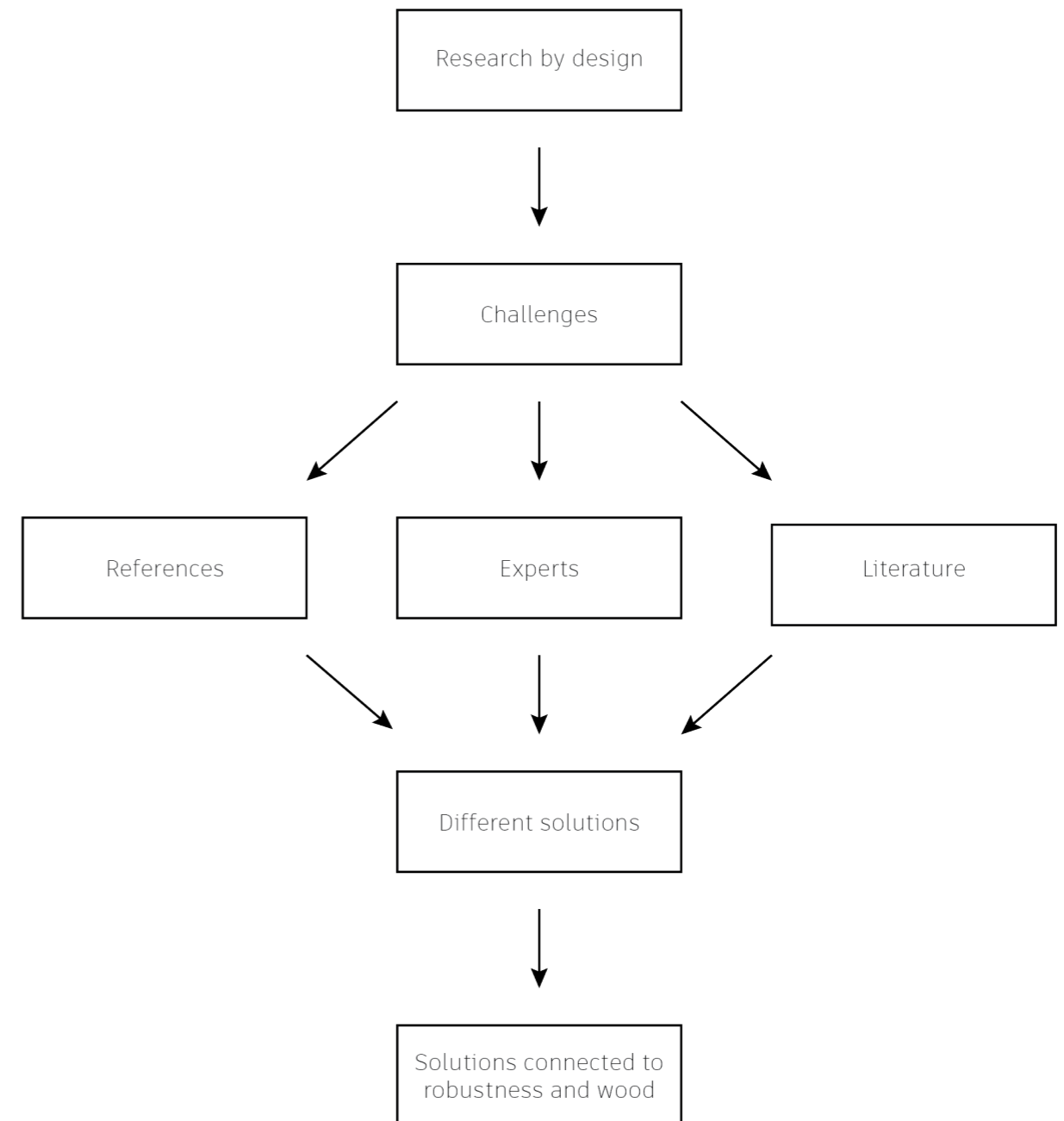

Background

Wood as a construction material has been used for centuries but it is quite recent that larger buildings with more difficult technical solutions started to develop the use of wood. There are many reasons why wood has not been used in larger constructions. The fire resistant as well as the moisture resistant qualities of example concrete have given wood a hard time to keep up with growing cities. The strength of steel made it the clear choice when working with larger distances and heavier loads. But in the last decades a lot of exploring and investigation have been done to develop new and better strategies for working with wood. A big reason for this shift in mindset towards wood as a material for larger construction is the climate challenges our society faces. The climate impact from wood has been shown to be vastly smaller compared to the usage of steel and concrete. Because of the fast development of strategies on wood as a material, new methods to make it both more fire resistant and more moisture resistant have been found. New methods to use wood to better fit different scenarios and be able to carry heavier loads. (Eriksson, 2000)

In many projects the design and structural solutions are divided. The architect is the designer and the engineer solves the structural needs. Usually in the planning process the design is primary and the structure is to be solved to allow the designs. Rarely are the structural solutions primary together with the design. Many architects try to keep a sense of how the building will be built when designing but it often ends in the mindset of “we solve the construction later”. The structure, the internal skeleton, has three main purposes. It is supposed to make the building strong, stable and stiff. In many modern buildings the internal skeleton is not supposed to be visible. It is the design that should be visible. The structural parts of a building are often viewed as the necessary parts and not wanted parts in a design perspective. (Designer 2015)

Robustness

The definition of the word “Robust” according to the Cambridge dictionary (n.d) is “strong” and “not easily breaking”. Robust is a more formal word for something durable. In the context of architecture this often refers to a resilient structure. The buildings should be able to carry themselves and the purpose within. The architecture should contain a load bearing system that is, in a logical way, strong and durable to be able to withstand the environment such as harsh weather to create good livable conditions. The climate impact is often mentioned when discussing robust architecture. Something that will last, without putting too much weight on the climate. The use of climate friendly materials and methods to create architecture that is durable and strong in its independence. (The Municipality of Lindköping, 2023).

“Robust architecture is designed to meet needs; its structures are sufficient, resilient and suited to the location. It embraces the potential of simplicity, traditional building methods and alternative ways of building sustainable architecture, with an emphasis on local building materials, solid craftsmanship, proven construction methods and user participation.” (Detail, n.d).

“Robustness is a key component of resilience, in order to avoid the structure’s disproportionate failure to the original cause” (Koutsomarkos, V, 2023).

Construction

Architectural elements that usually are looked at as separate things such as space and construction or atmosphere and function. But the theory of tectonics seeks to intertwine these architectural elements into something new. To let the design of art and the design of science become one and the same. Tectonics means to let construction and materials influence the architectural expression. To let different building elements join together to create space. Tectonics does not only refer to the methods of creating a structure that answers to certain needs but also creates the structure to a form of art. (Maulden, R, 1986 ; Schwarz, C, 2016).

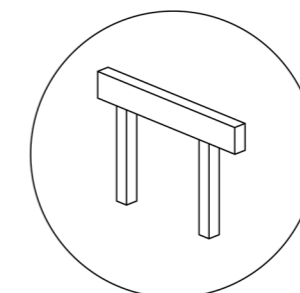

Fire resistance

Fire has for a long time been a vulnerable flaw of wood. The flammable aspects of wood have historically always been a challenge. But according to Birgit Östman there are actually some benefits with wood when it comes to fire resistance. Wood is flammable but it burns in a quite controllable way which allows for preventive measures. Steel for example, which is not flammable, instead gets very hot and starts to melt, losing its load bearing capacity. Wood can keep its load bearing capacity for a long time even when it burns. This means that with the right fire resistance measures, wood is a strong contender to other non-flammable materials.

(Brandt, K, 2014).

Fire resistance is a key aspect of achieving a robust building. The preventive measures are crucial to minimize the risks of a fire incident occurring. But also to prevent as much damage as possible if a fire incident would erupt. There are different aspects on the importance of fire resistance in connection to achieving robustness. One example is that protection of the property allows for a more sustainable long term building. But the most important aspect of fire safety is of course the protection of human life. To ensure the safety of the occupants of the building. To prevent injuries and loss of human life.

(FPC Risk, 2023).

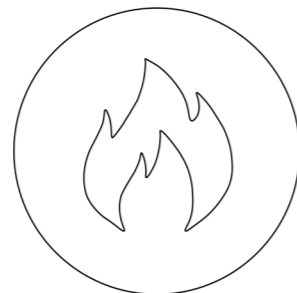

Indoor climate

Ventilation is important in buildings to maintain indoor air quality. Good ventilation generates many positive and important aspects of a good and robust indoor environment. Improving health and concentration for the occupants by providing fresh oxygen. Good ventilation also removes the bad parts in the air such as pollution, odors and moisture.

(Health and Safety Executive, n.d).

Ventilation also helps regulate the indoor temperature. Controlled ventilation provides controllable temperature. Suitable temperature is crucial to achieving a comfortable working environment. There are risks that can affect human health in negative ways. If the temperature is too warm or too cold it can both generate different negative aspects to the indoor working environment. A cold environment can cause different strain injuries. For office work it is common to receive torticollis, also known as wryneck. Too warm indoor temperature increases the risks of headaches and nausea.

One other way to regulate the indoor temperature is by shading for the sun. Direct sunlight can generate a high amount of heat and raise the temperature to an uncomfortable amount. (Arbetsmiljöverket, 2023).

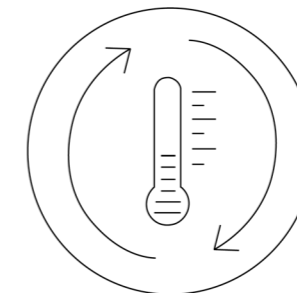

Noise reduction

To use a building to its full potential goes together with robustness. Creating a good environment for people to spend time in. Bad noise quality affects humans in more ways than one. It can reduce concentration, increase stress and generate exhaustion.

To achieve robustness and a good working space, noise reduction solutions should be implemented.

(Efterklang, n.d).

Noise in a building can be divided into two categories.

Impact noise is the noise generated by impacts and are usually transported through walls, floors and other solid objects. Examples for this type of noise are footsteps.

Airborne noise is the noise transported through the air. Examples of this are people talking or phones ringing.

(Baker, I, 2021).

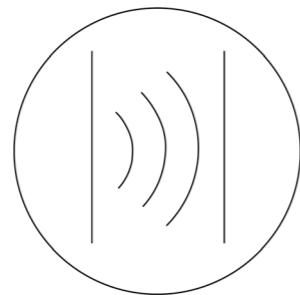

Maintenance

The different systems, structural capabilities and human health aspects of a building, which are necessary to achieve a robustness, can through maintenance operate in higher efficiency for a longer time. This makes maintenance very important in a robust building. Whether it is indoor or outdoor, different maintenance methods can be used to optimize the performance of the building.

Maintenance can reduce the risks of property damage and safety aspects. In the perspective of sustainability, maintenance is very necessary. Continued maintenance measures ensure a longer lifespan of the building, creating a more sustainable project.

(Chapman, S, 2022).

Different materials have different needs of maintenance. Wood is a material that has great potential but has a big need for maintenance. The location and exposure to weather greatly affect the lifespan of wood. The need to protect the wood from exposure to moisture, insects and other forms of conditions is necessary to achieve robustness with wood. There are many different methods used, both in protection of the wood or maintenance of the wood.

(Timberqueensland, 2018).

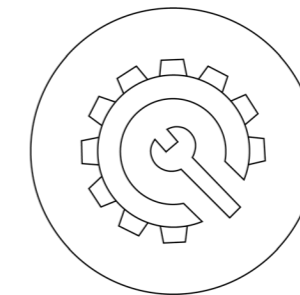



Nodi

Location: Nya Hovås, Gothenburg
Architects: White Architects
Year: 2021

Nodi is an modern office building of five floors with shops on the ground floor. The main concept of Nodi is the usage of wood, both interior and exterior. The facade uses oil treated wood for protection and provide natural sun shading by extending each level outwards. The interior of Nodi is also all wood. High ceiling heights and a tectonic structure of visible glulam.

(White Architects, 2021).

NODI is a reference in this masters` thesis through drawings, a site visit and discussion with an architect involved in this project. The inspiration from NODI has been used both in design and function. The main inspiration used is in relation to floor plan and adaptability.



Habitat 7

Location: Masthuggskajen, Gothenburg
Architects: Krook & Tjäder
Year: 2024

Habitat 7 is an modern office and provide around 8000 m² of office space on nine floors. The usage of wood is one of the main concepts in Habitat 7 both interior and exterior. It uses wood in the facade in different ways, both as panels and as the motive behind large glassed areas. Interiorly it consists of large wooden column and beams where the tectonic structure is visible.

(NCC, 2023).

Habitat 7 is a reference in this masters` thesis through a site visit and discussion with a structural engineer involved in this project. The inspiration has been used both in design and function. The main inspiration used is in relation to structure and construction.

Context

Northern Offshore Services

The Client

Northern Offshore Services (NOS) is a company with strong connections to the sea. Their main business is within the offshore wind industry. With vessels of different sizes they provide transport for different professions out to wind farms in the ocean.

The identity of NOS is very important for the company. They work a lot with what their brand stands for and it is important for them to provide the best services all year around hence the motto "Best 365". Quality, high performance and high standards are words they would use to describe themselves and they proudly work with sustainability and efficiency.

Project ambition

Northern Offshore Services together with their affiliates becomes The Northern Offshore Group. They are today scattered around northern Europe but also scattered around Gothenburg. Their dream is to gather the whole of The Northern Offshore Group and to have one centered headquarters for all their personnel in Gothenburg and have the possibility to grow in staff. The project is a new modern office building together with warehouse storage. N-O-S wants their image to be embedded within the design of their new office. Sustainability and efficiency are two keywords they wish to shine through the building. N-O-S dream to have a timber constructed building with a design of robustness. In this scenario N-O-S has bought a plot in the harbor of "Nya Varvet" - Gothenburg. The buildings on the site are to be demolished and a new office building is to be built. They also aim to provide vessels in their fleet the possibility to berth next to the new headquarters.



Brief

The brief can be divided into two main flows. The office flows and the industrial flows. The industrial flows main need is to be connected to a large warehouse. The warehouse is supposed to be about 1500 m². The industrial spaces can be divided into 1000 m² + 300 m² high storage and 200 m² workshop.

The office flows include both office workers as well as clients and guests to the buildings occupants. The total space for the office space is around 4000 m² with office space to accommodate about 200 people. Some functions connected to the office flows can be separated from the working office space. The project is to house a dining hall with kitchen for about 200 people. The building should also house an inviting lobby, gym for the employees and a small apartment for international employees visiting the office.

The office spaces can be divided into different tenants. Northern Offshore Services (NOS), the largest tenant in the building needs office space for about 200 people. Other than NOS there are other smaller companies included in the brief. Northern Energy Supply (NES) is the second largest tenant with the need for office space for about 30 people. The remaining 70 people are distributed in smaller tenants and office functions that can change overtime.

In this case study the main focus will be put on the office functions. The warehouse functions will be mentioned and designed but not thoroughly studied.

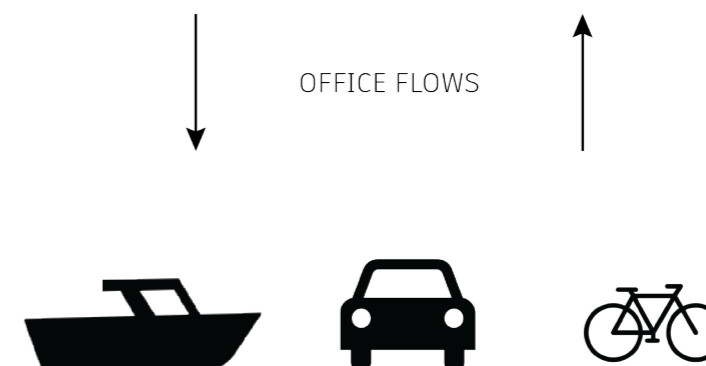
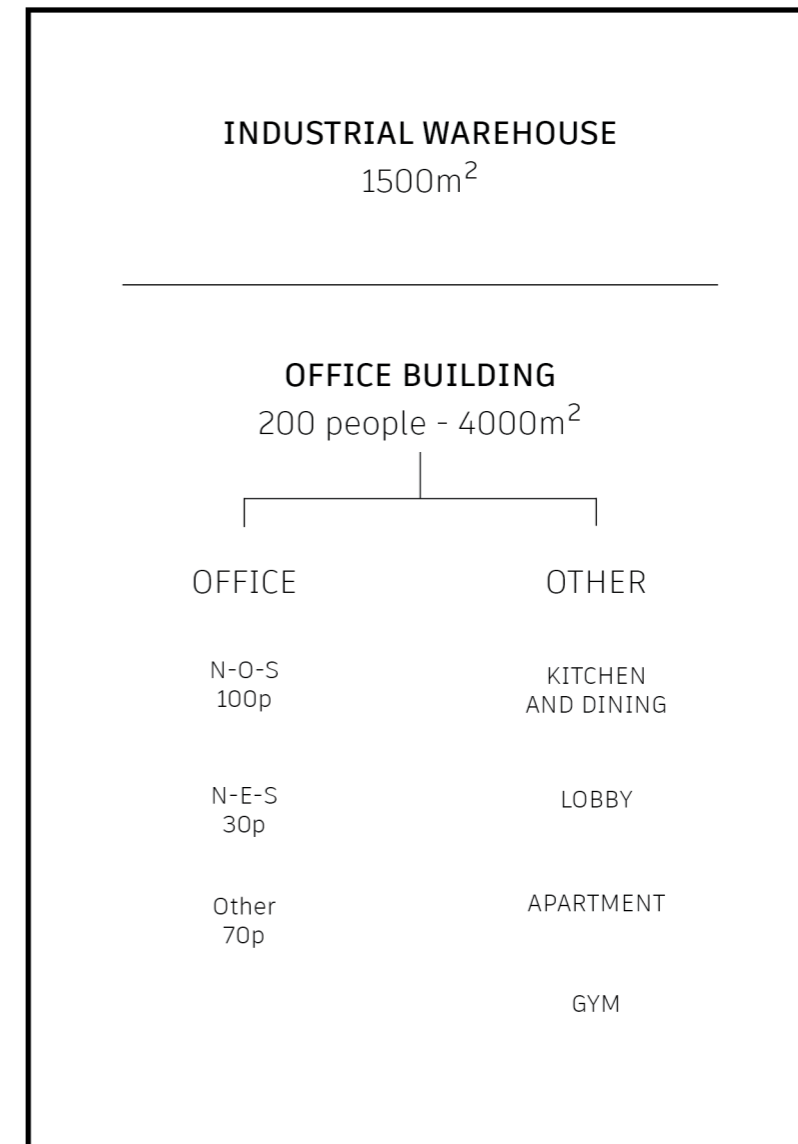
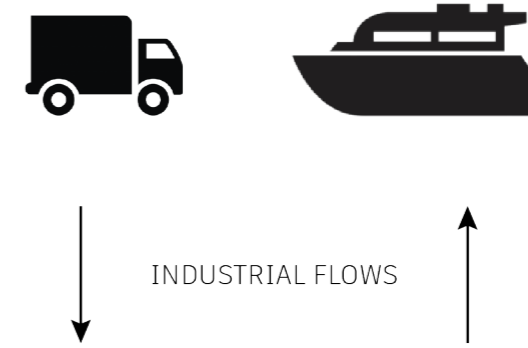

The Site

“Nya Varvet” (The New Shipyard) is an area in the harbor entrance of Gothenburg. Towards land Nya Varvet contains mostly residential buildings but further out towards the water, in the harbor of Nya Varvet, exists a university, some public businesses and many companies with a connection to the ocean. The majority of the facilities in the harbor are offices and warehouses together. Many of the boats and ships in the harbor belong to the different companies working on the ocean in some way. Towboats and research ships are two examples of the industrial ships in the harbor but there are also a few smaller, private boats in the area. The harbor of Nya Varvet has a mixed atmosphere of the cozy marina as well as the more rough industrial harbor. In the past, Nya Varvet was a military area but became public in 1986 but there are still some signs of the military characteristics in the buildings of the area.

The chosen plot

A specific place was chosen to be the plot of this master’s thesis case study. The chosen plot is today used by “Göteborgs Dykeriteknik AB” (Gothenburg diving technology). On the plot there are a small warehouse and a small office building. The current occupants of the plot uses vessels which they berth on the three piers connected to the site. In this fictitious case study the plot is empty.



Landscape

The landscape of the site is clear. A close and smooth connection to water in one direction and a abrupt stop with mountains in the other direction. This gives the site a clear front and backside.

The site also allow for the possibility to use it's relation to water.

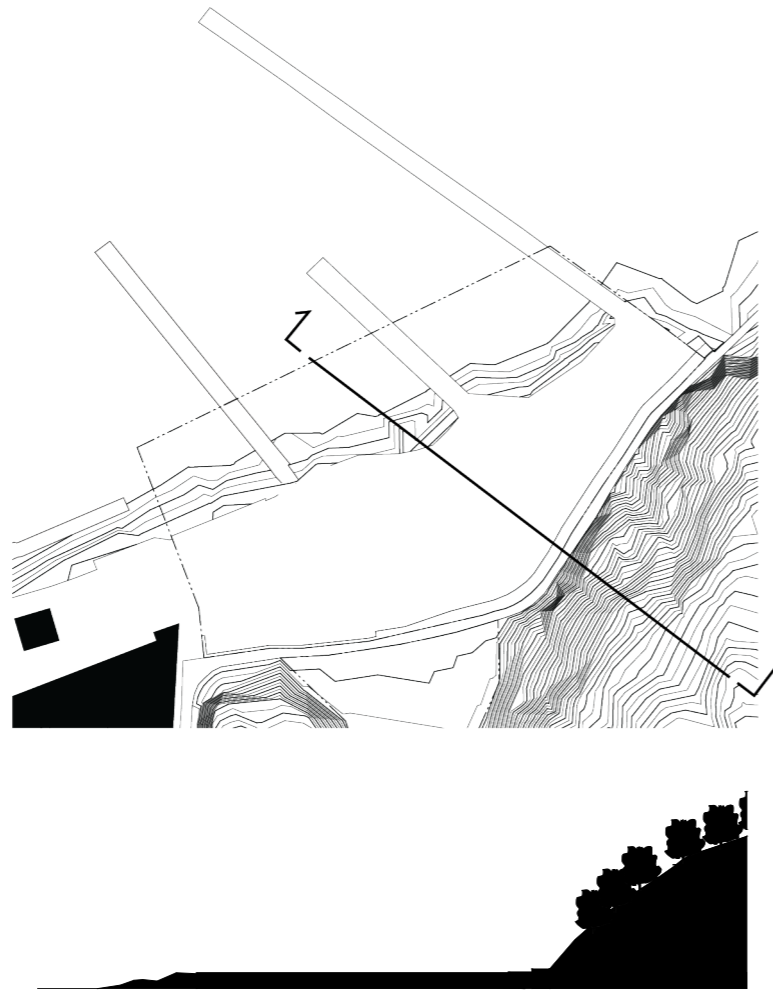

Views

The views from the site is divided into two sides. One side towards the water and one towards the mountain barrier. This further display the clear front side and backside of the site.

The main views are out towards the ocean in the west.

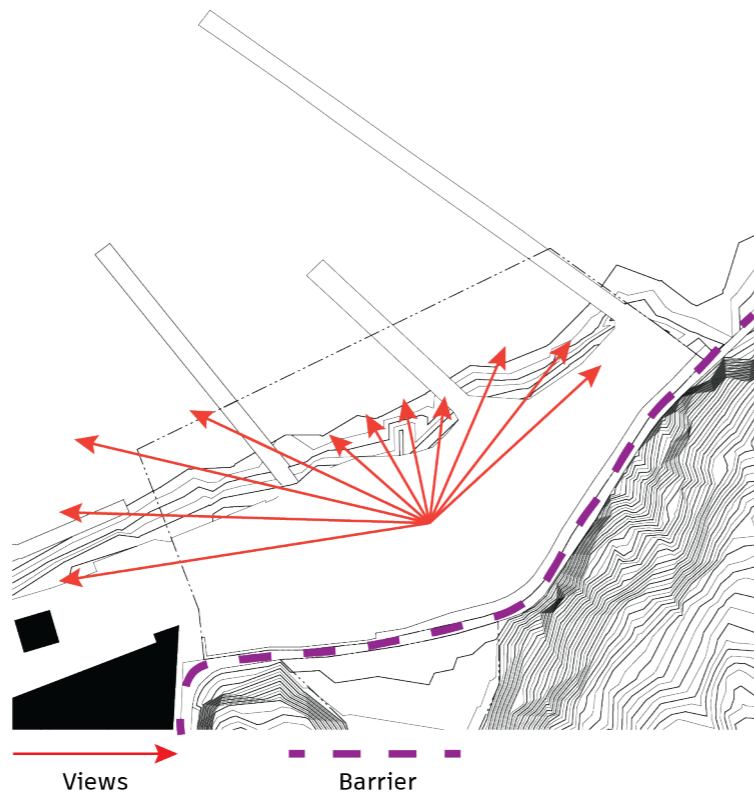

Access points

The plot has one clear access point in the west, not counting the possible access by boat. This makes the west access point important when it comes to managing the flows.

The two eastern piers are made of concrete which allow larger vessels the berth. The pier to the west is made of wood.

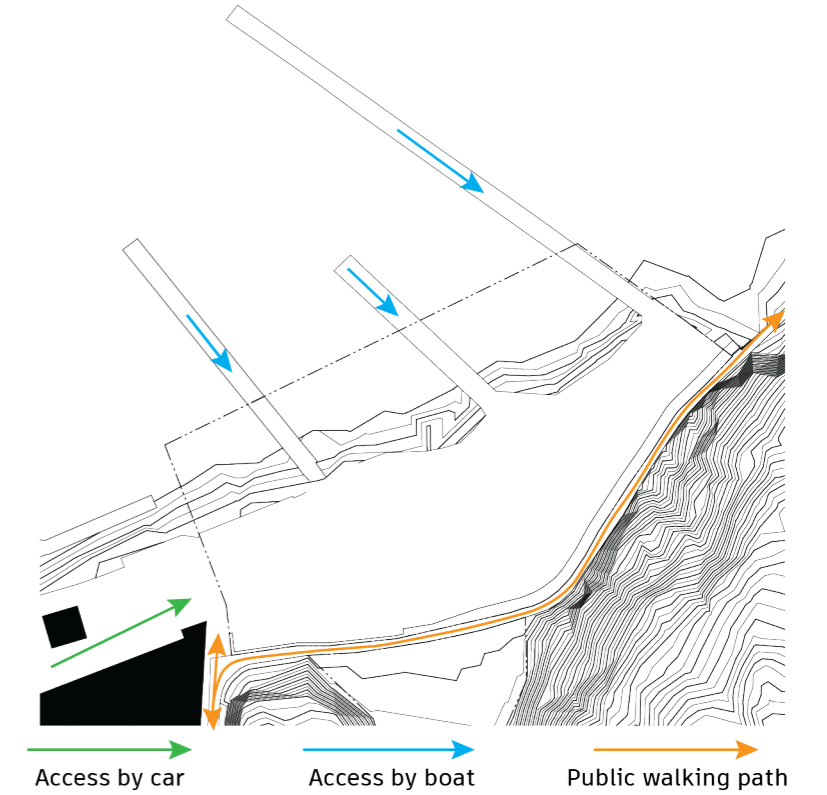

Sun path

In the summer when the sun is high the terrain in on the site will not reduce the amount of sunlight. But in the winter when the sun is low it will take a longer time for the sun to rise behind the terrain in the east and south.

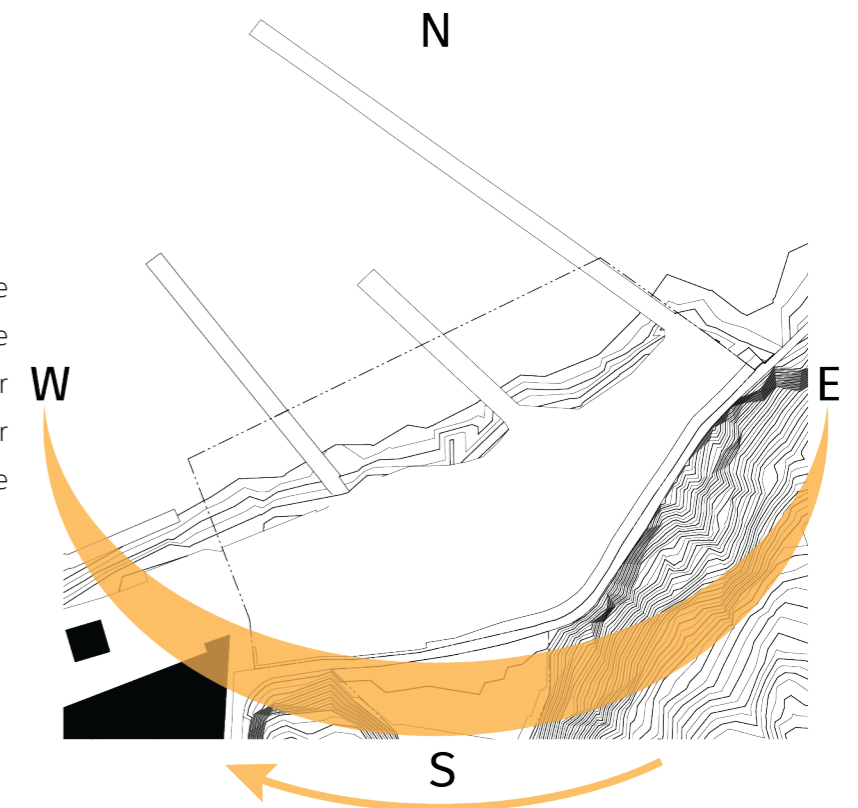

THE PROPOSAL



The proposal

The proposal consists of two buildings next to the water, an office and a warehouse. They are recognized by their blue wooden facades which not only reflects the ocean and the harbor character with a modern look, but also embodies the identity of the householders Northern Offshore Services.

The proposal are designed to use wood in as many places as possible while still leaning into robustness and logical solutions. Using a tectonic structure as a part of the design both interior and exterior. The proposal gives a transparency in both form and function throughout the building.

The office building, a five-story structure with generous views and outdoor spaces for personnel. Great office spaces and a large dining hall on the ground floor for about 200 people. With a footprint of about 900 m² and a gross total area of about 4000 m². An almost symmetrical square building with a smaller floor on top.

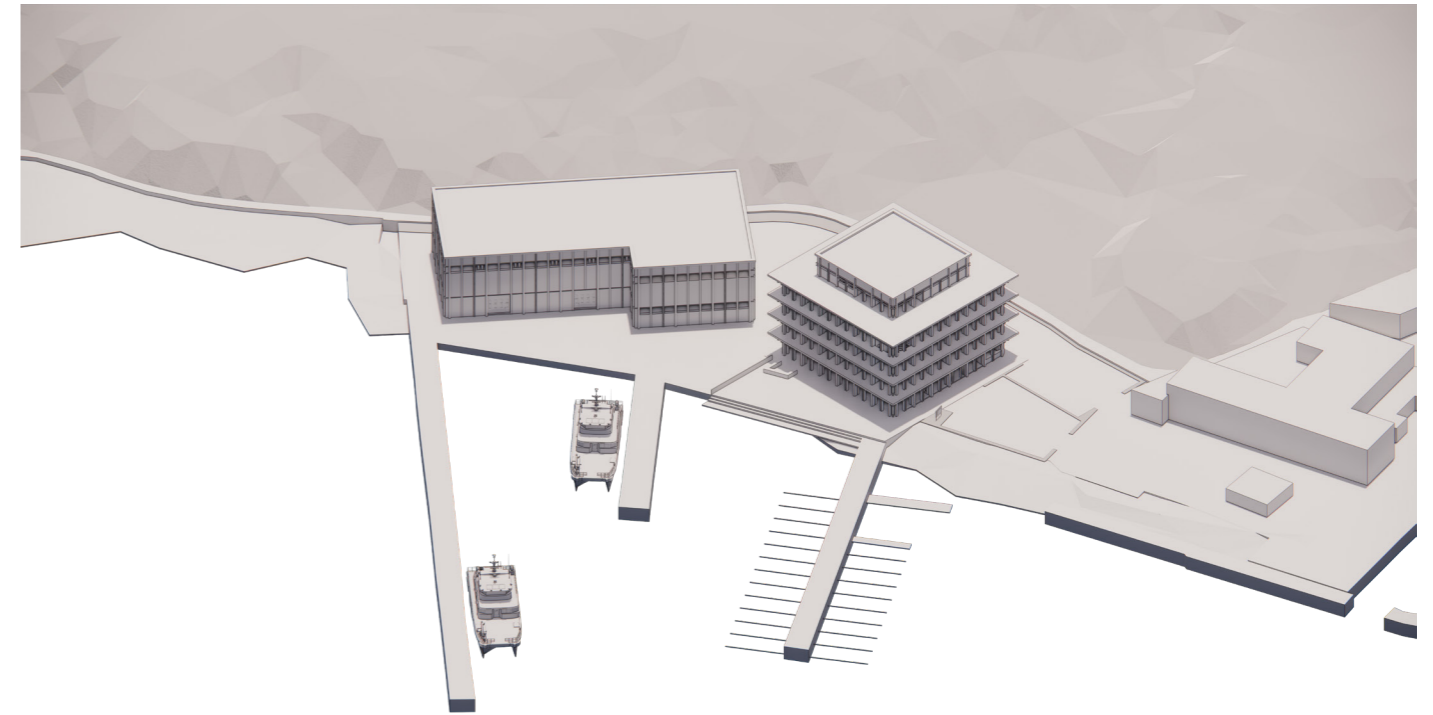

Bird perspective over the site



Ground perspective from the wooden pier

The first step was to separate the brief into two building, one warehouse and one office. With regards for the large difference in high and flows between the different functions, this allowed for the buildings to better manage their specific functions.

The office building was placed in the west and the warehouse in the east. Both because of the positions of the different types of piers managing different flows and because of the ambition to have the office building as the inviting structure close to the access point.

The views to the west was also preferable in relation to the office building.

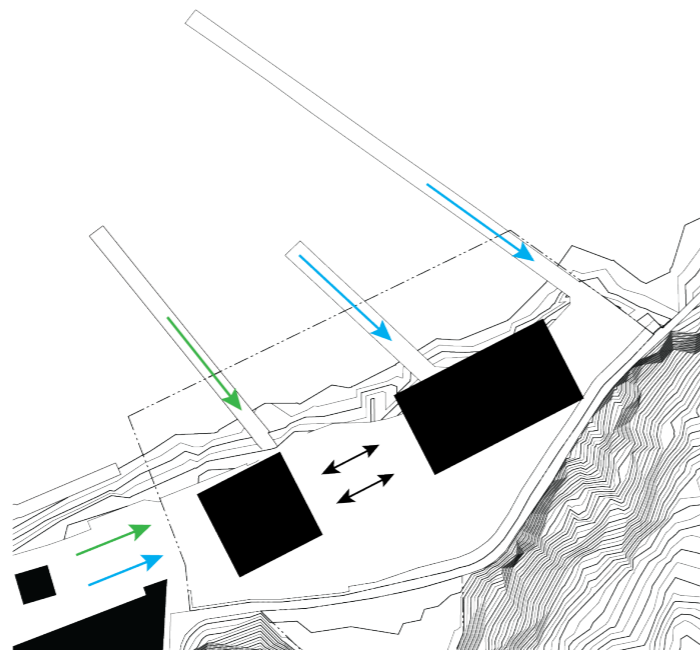

The next step was rotate the buildings to more preferable spots. The warehouse as close to the backside as possible to allow more space in front of it and the office building rotated to better fit the plot and strengthen the views and sun path. The rotation of the office building also better handles the office flows and allows the industrial flow to go behind it.

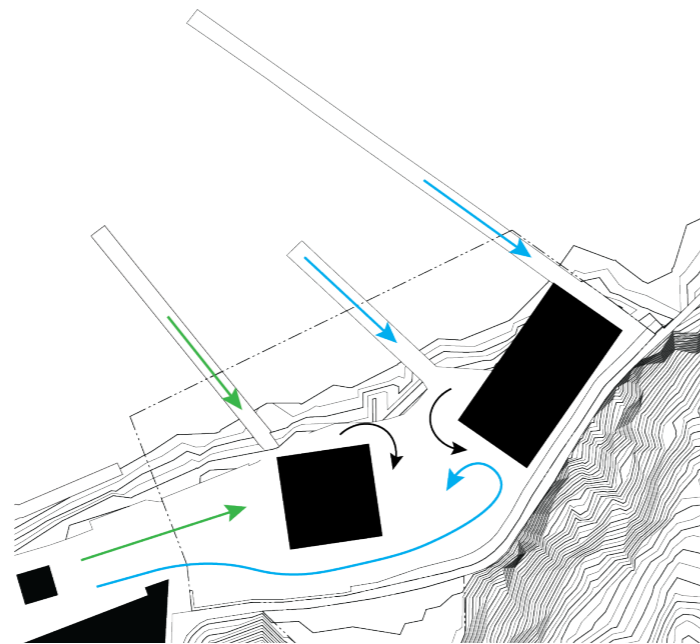

The last step was changing the form of the buildings to fit the brief and increasing the space towards the water. More industrial space in front of the warehouse and a large wooden deck next to the water in front of the office.

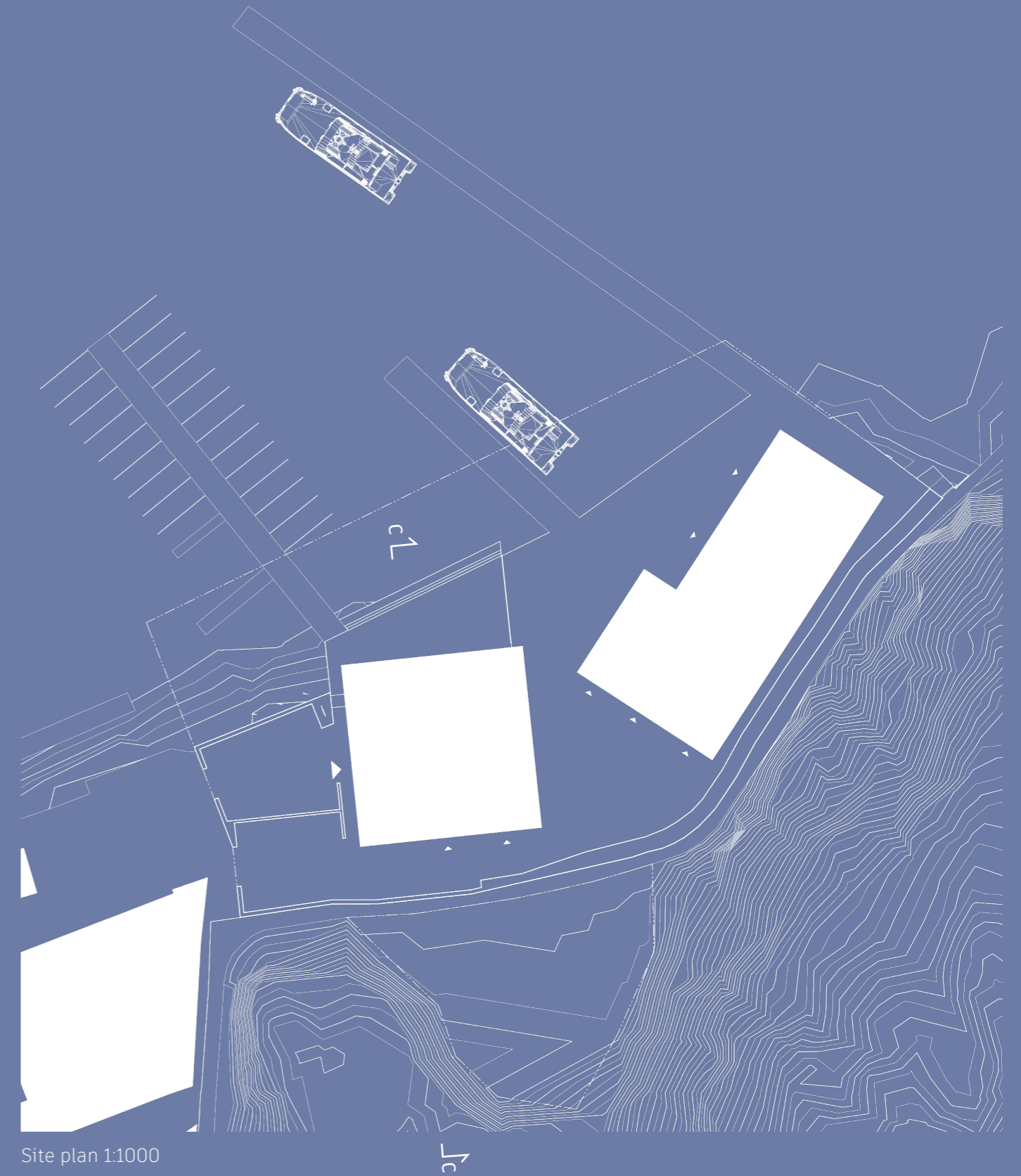
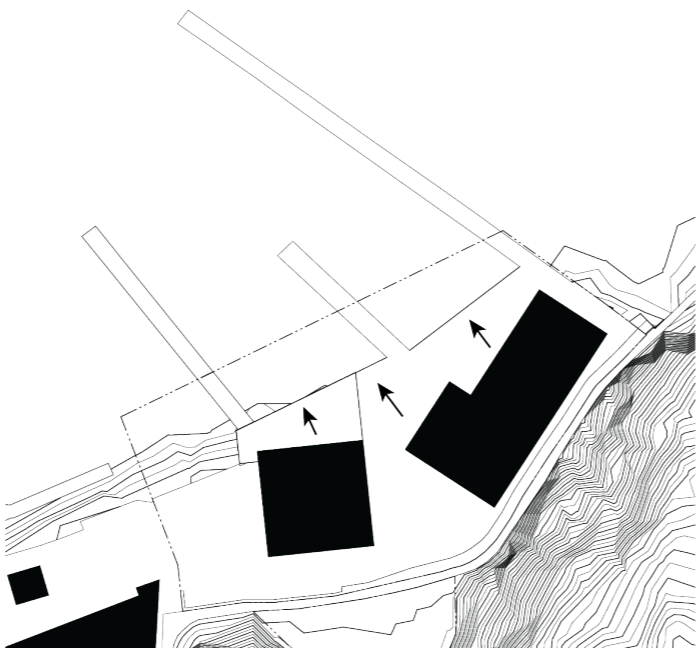

Site plan 1:1000

Section C-C 1:1000

Adaptability

Adaptability in a building is a step towards robustness. To allow for future changes without large renovations strengthens the usability of the building and increases the possibilities with usage. Easily adaptable buildings also benefits the sustainable aspects of the project in long term.

The floor plan is structured around a centered core. This core contains the vertical communication from where people reach each floor and access the office space. The centered core also allows for an easy division between segments in the floor plan. Even if this project is specifically design for one proprietor and one brief, the brief contains offices space for connected businesses but still different companies. Being able to divide the floor plan into smaller segments is a crucial part of this project. The possibility to divide the office floors also gives the proprietor a possibility to rent office space in the future if things change. Adaptable floor plans allows this building to still be in efficient usage even if the proprietor were to move in the future.

The floor plans can be divided into four separate sections. The surrounding balcony makes sure that all tenants have the possibility to reach two different directions.

To maximize the possibility of easy adaptability the choice were made to have the bathrooms inside the centered core. This is an inspired decision from the project Nodi by White architects. By situating the bathrooms inside the center provides many benefits. This solution reduces the amount of accessible bathrooms to one on each floor instead of one per different office tenant. There is no need to construct new bathrooms in the future if the office floor plan changes. During construction and for maintenance this solution is also a strength because it gathers all sewage pips into one shaft.

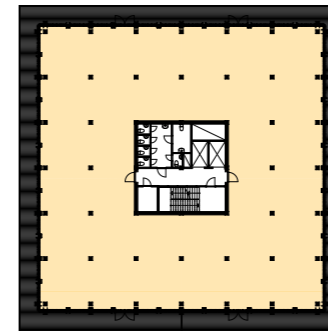

One tenant on one floor.
Dividing the floor into one large office.

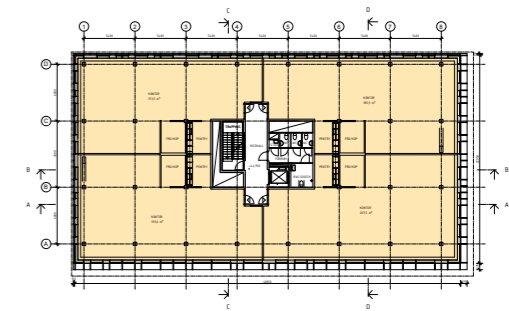

Nodi floor plan example

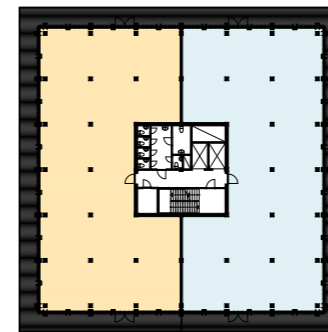

Two tenants on one floor.
Dividing the floor into two sides of the same size.

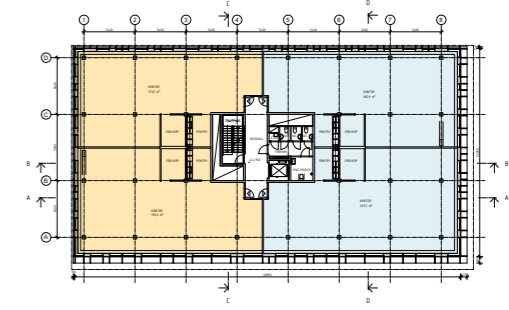

Nodi floor plan example

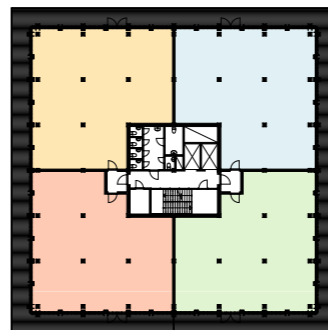

Four tenants on one floor.
Divides the floor plan into four segments of the same size.

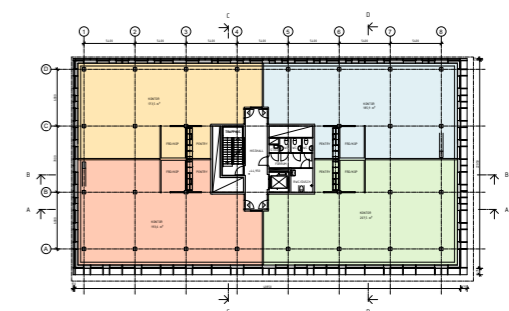

Nodi floor plan example

The project consists of a load bearing and tectonic structure of 4,8 meters between columns. Then the facade divides this dimension into two sections of 2,4 meters each. This gives the plan an adaptable structure of 2,4 x 2,4 meters. The adaptable floor plan can be used in many different ways to accommodate different needs and easily adapt to different tenants.

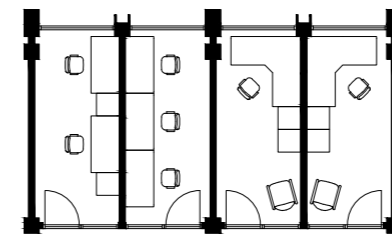
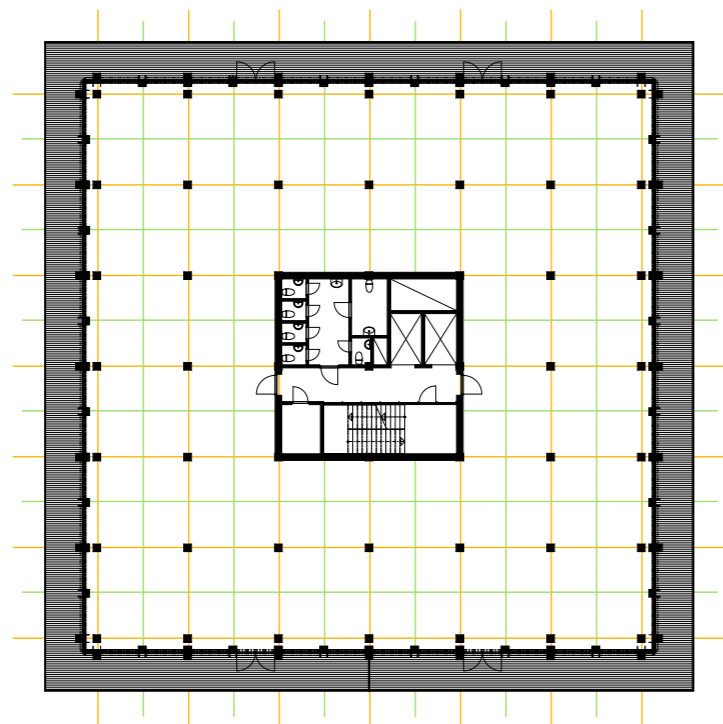

Four office rooms of the same size furnished in different ways.

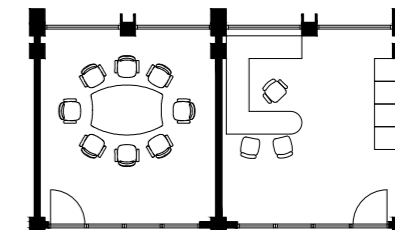

One conference room for 8 people and one larger office.

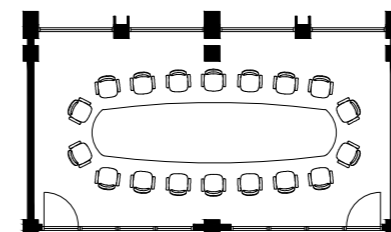

One large conference room for 18 people.

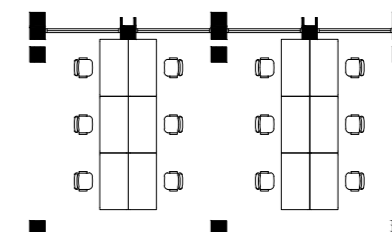

Office with open landscape with no surrounding walls.

The entrance floor

The functions on the entrance floor are mainly functions connected to the whole building and not just a specific tenant. A large inviting lobby for guests and clients visiting the office. The lobby is both designed to be a place of waiting and a place of exhibition. Dividing the space with the columns, creating natural flows and stops. Connected to the lobby is a small office corner for quick meetings with clients.

The main function on the ground floor is the dining space and kitchen. A large open dining space along the whole northern facade. With space for over 200 people and a small stage this hall can also function as a large gathering hall.

The large wooden deck next to the water serves as an extension of the dining space.



Perspective in the lobby

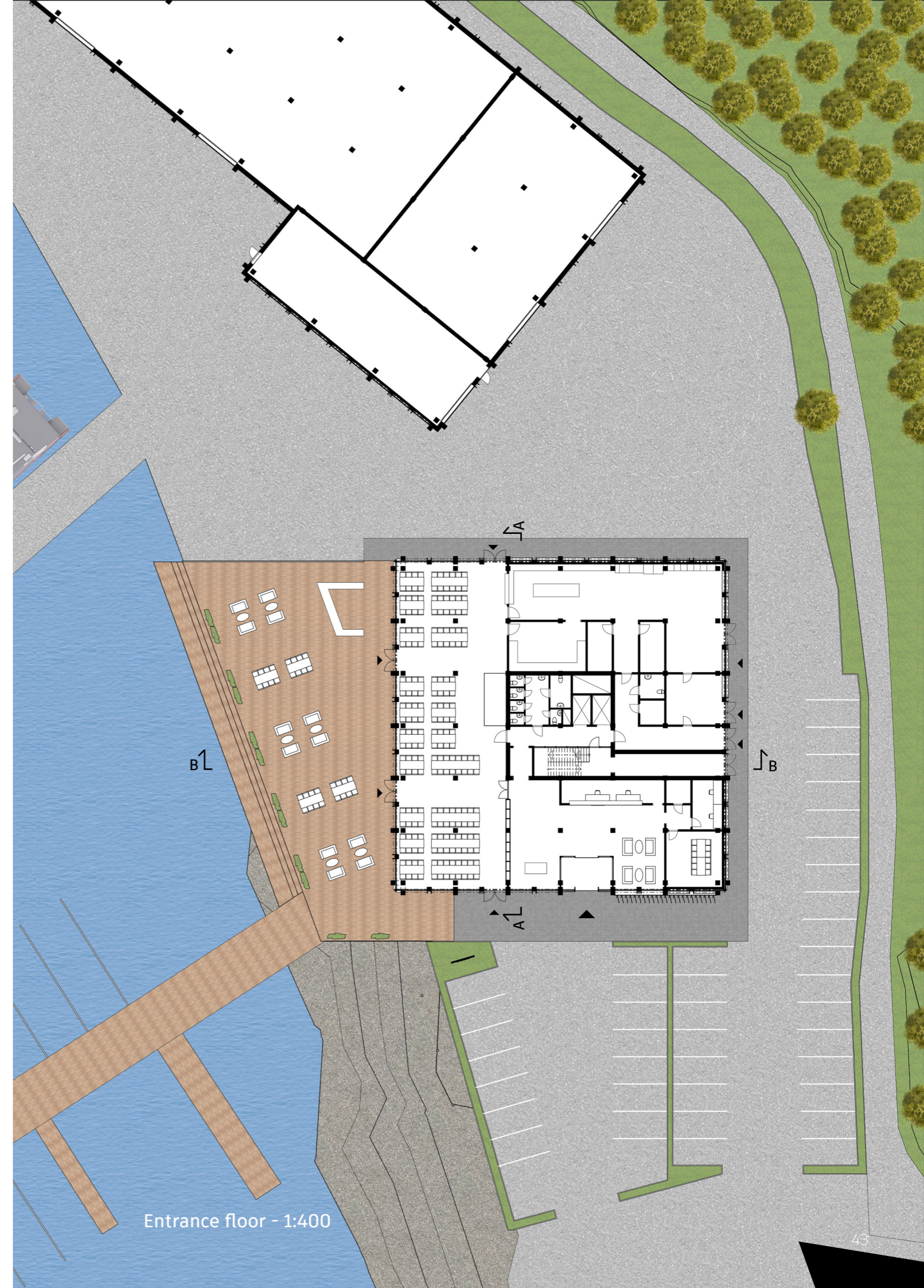

Entrance floor - 1:400



Perspective in an open landscape office

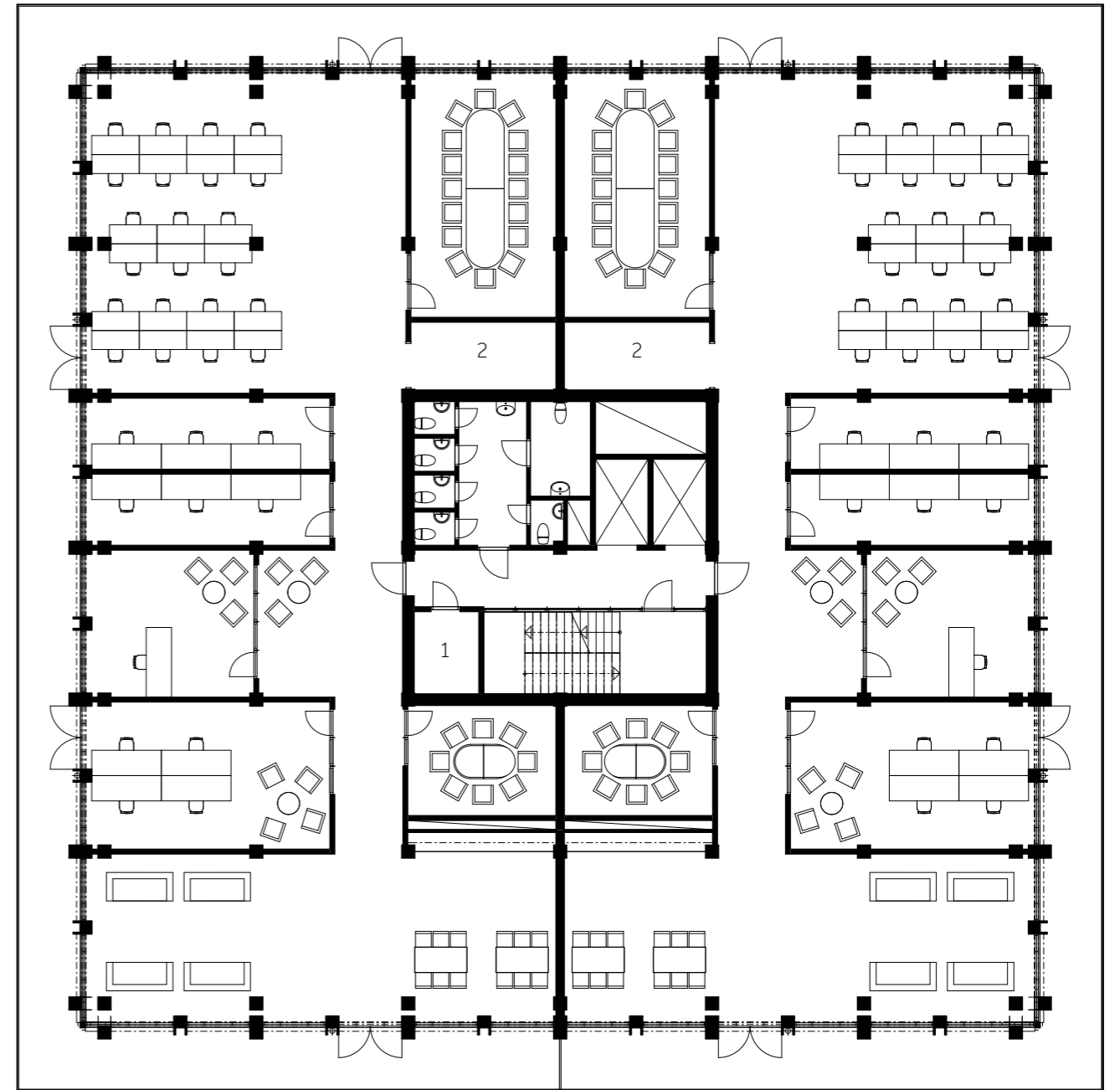

1st floor - 1:200

Divided into two sides, housing NES on one side and other office related function on other side.

- 1 Cleaning storage
- 2 Printer and Server



Perspective on the staircase between the 2nd and 3rd floor.

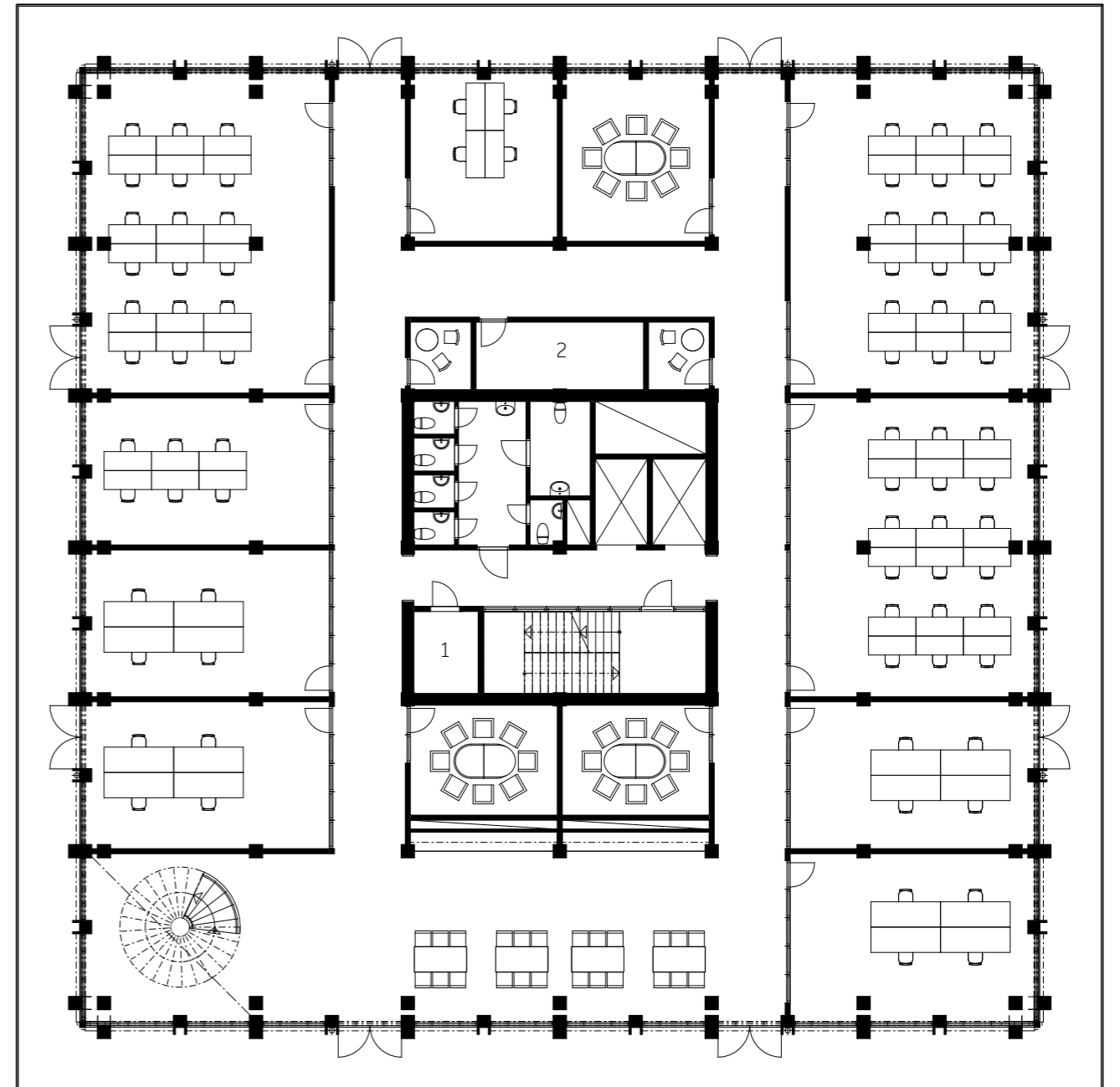

2nd floor - 1:200

Both the 2nd and 3rd floor are housed by NOS, connecting them with an additional staircase.

- 1 Cleaning storage
- 2 Printer and Server

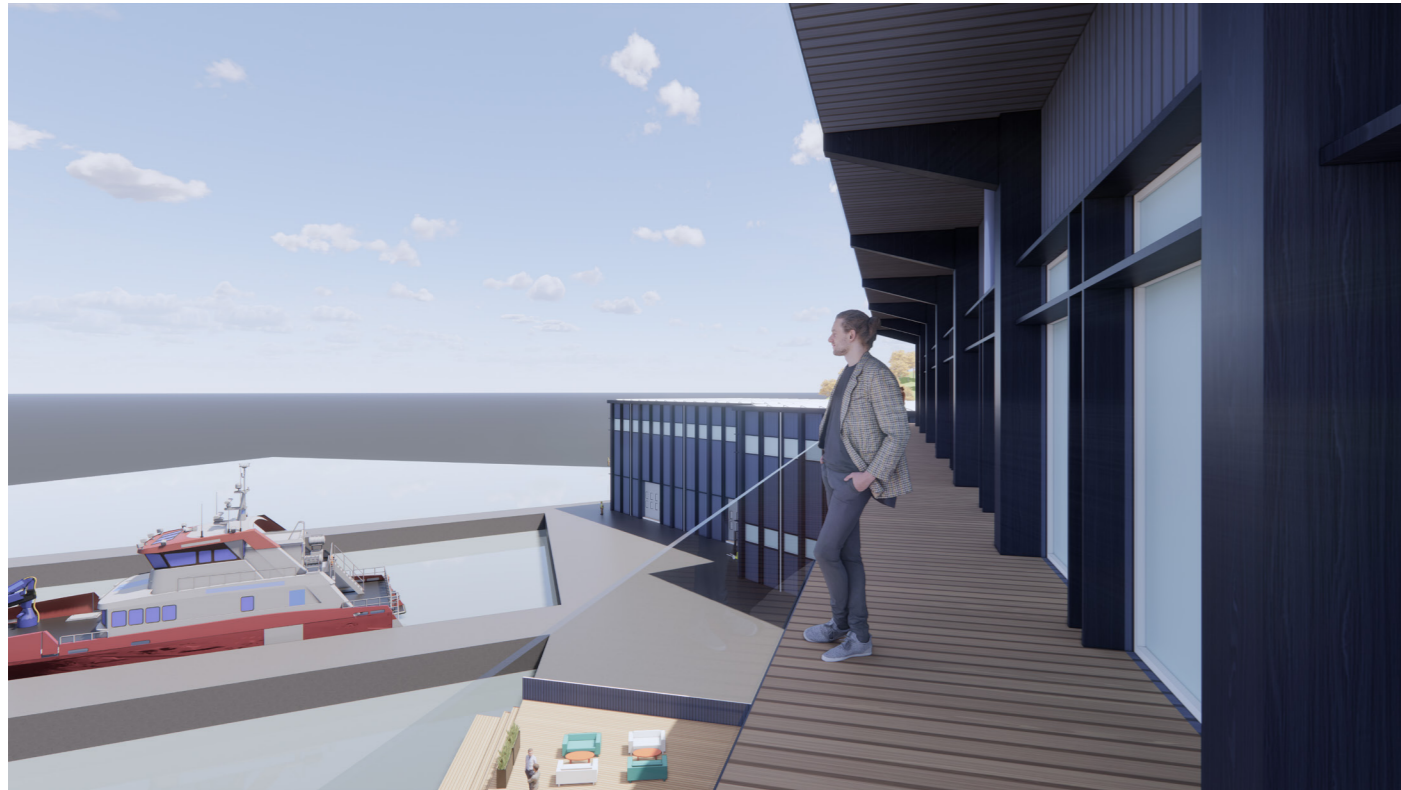

Perspective from the balcony on the north side.

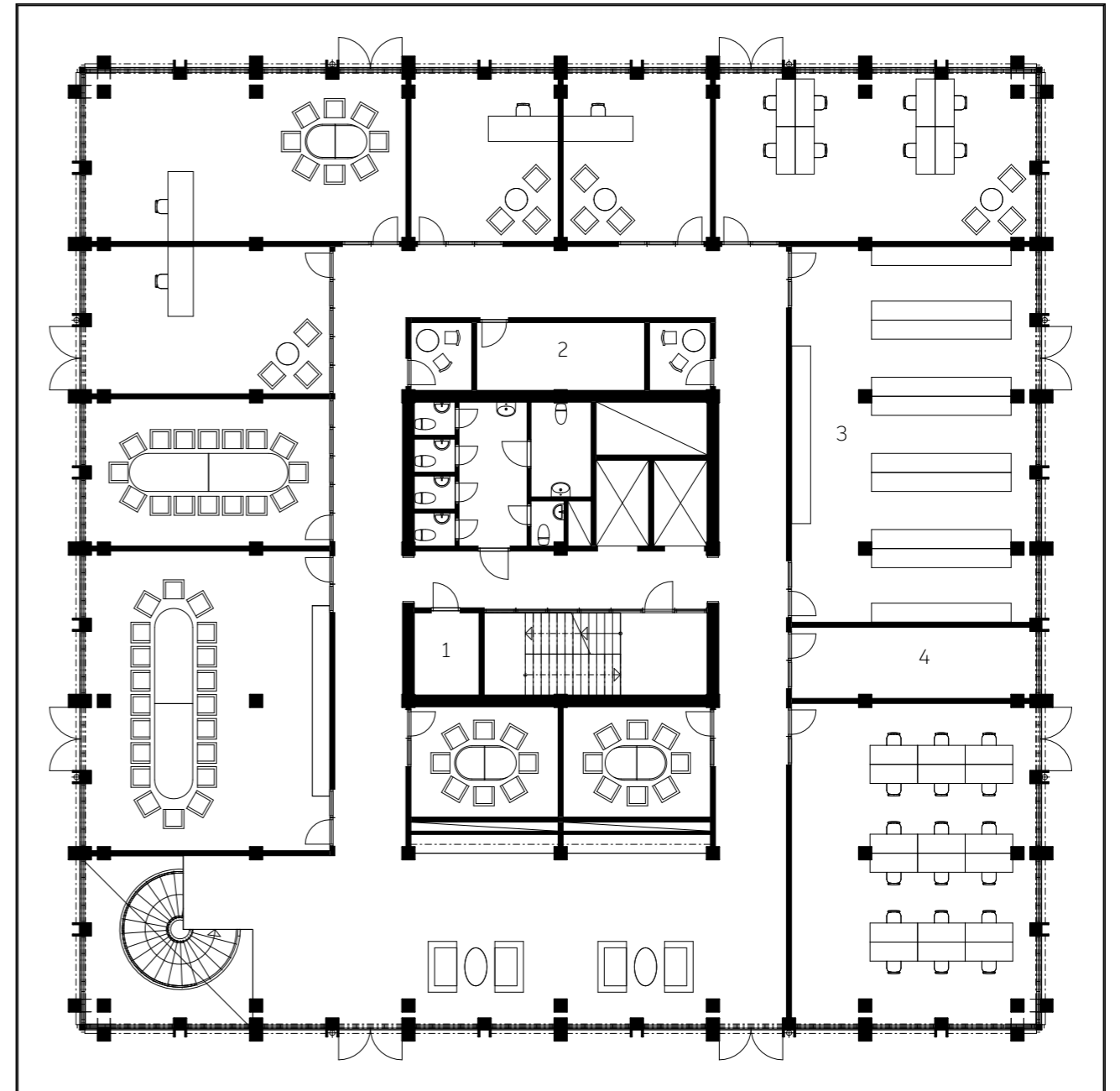

3rd floor - 1:200

Both the 2nd and 3rd floor are housed by NOS, connecting them with an additional staircase.

- 1 Cleaning storage
- 2 Printer and Server
- 3 Archives
- 4 Resting room

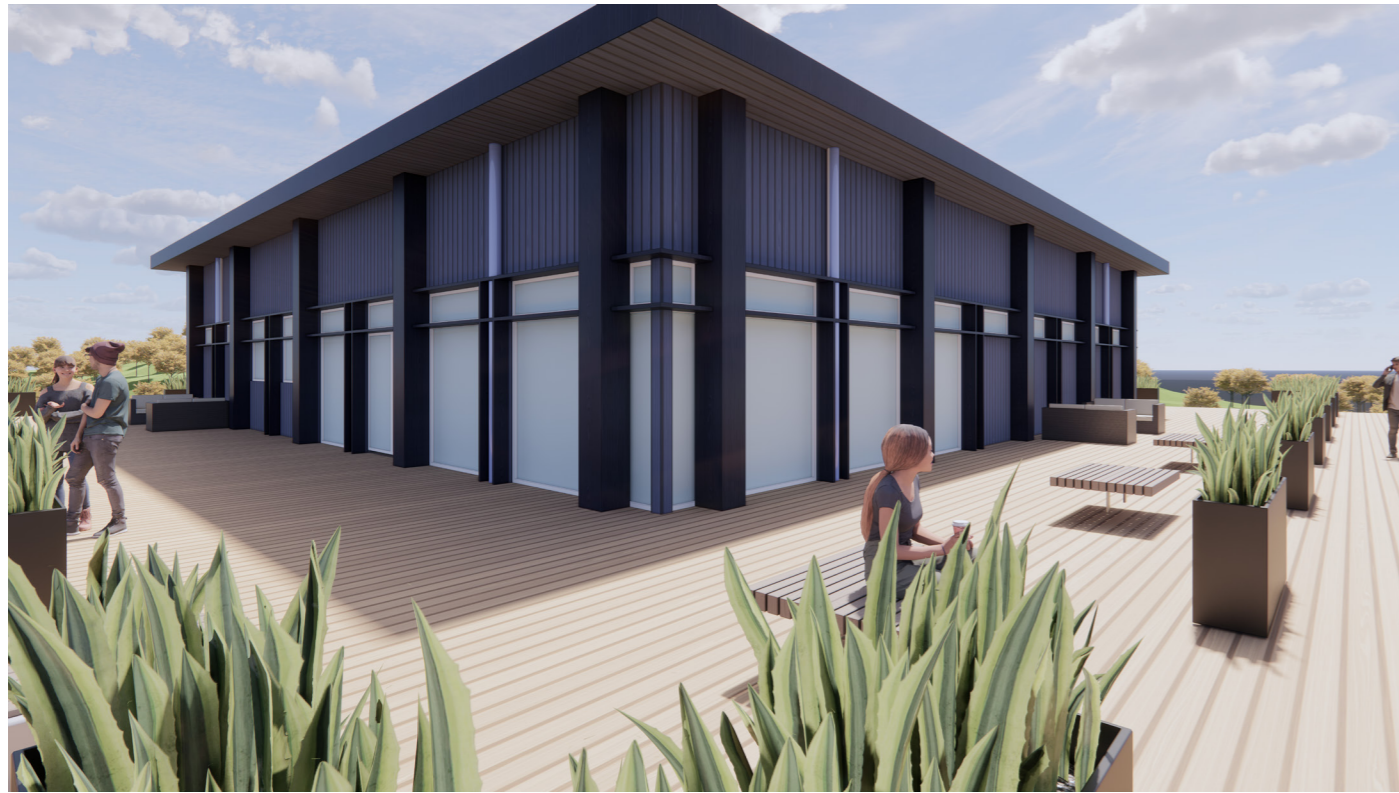

Perspective on the roof terrace

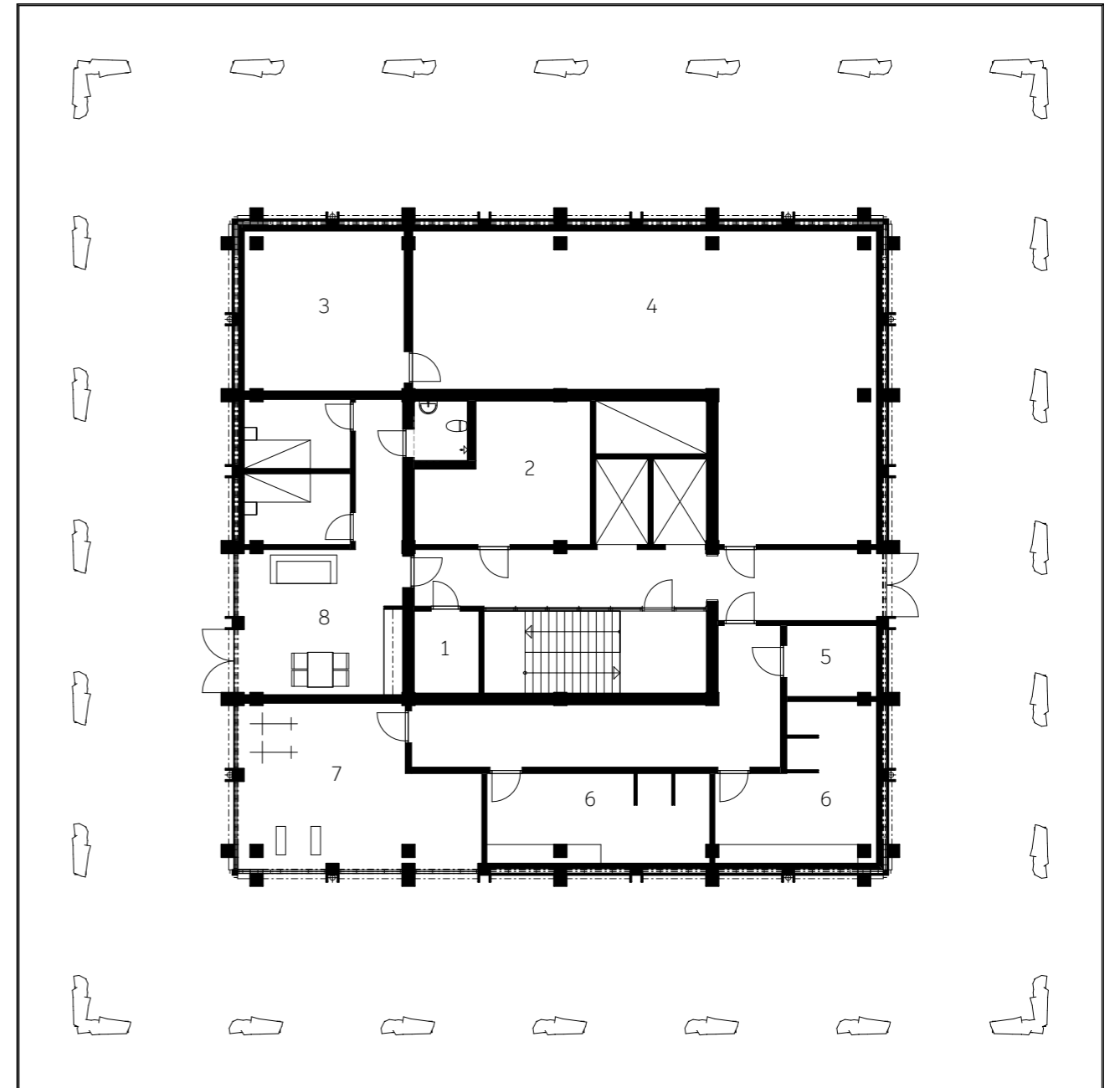

4th floor 1:200

The top floor includes other spaces than office space. Technical space, an apartment and a gym. On the outside there is a large wooden roof terrace.

- | | | | |
|---------------------|-----------------------|------------------|--------------|
| 1. Cleaning storage | 3. Sprinkler system | 5. Storage | 7. Gym |
| 2. Technical | 4. Ventilation system | 6. Changing room | 8. Apartment |



Perspective on the entrance



Section A-A 1:200

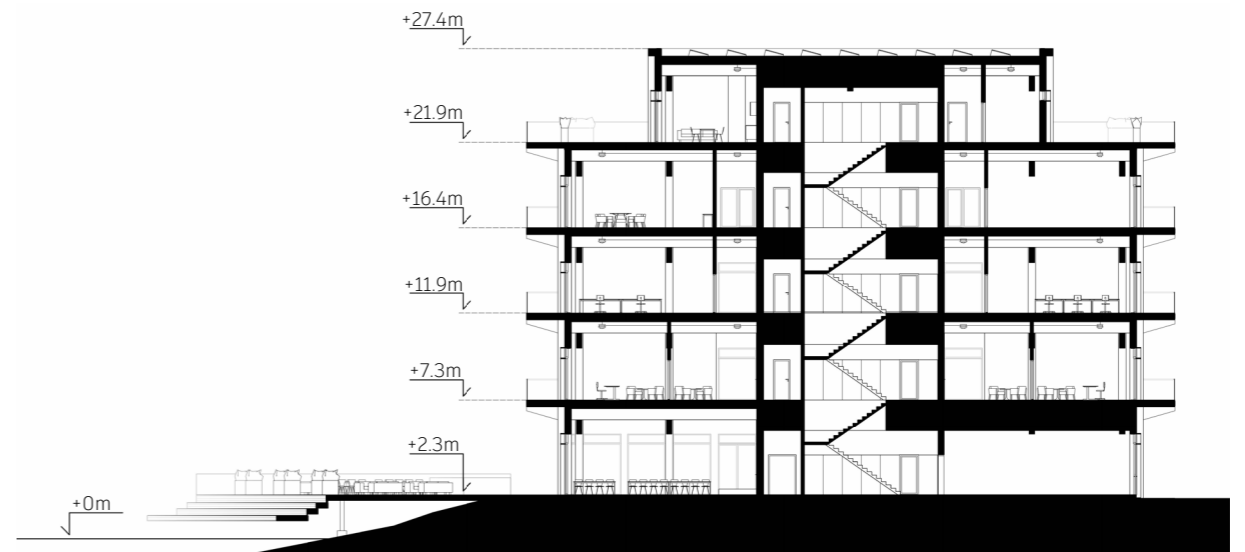

Section B-B 1:200



West Elevation 1:200



North Elevation 1:200

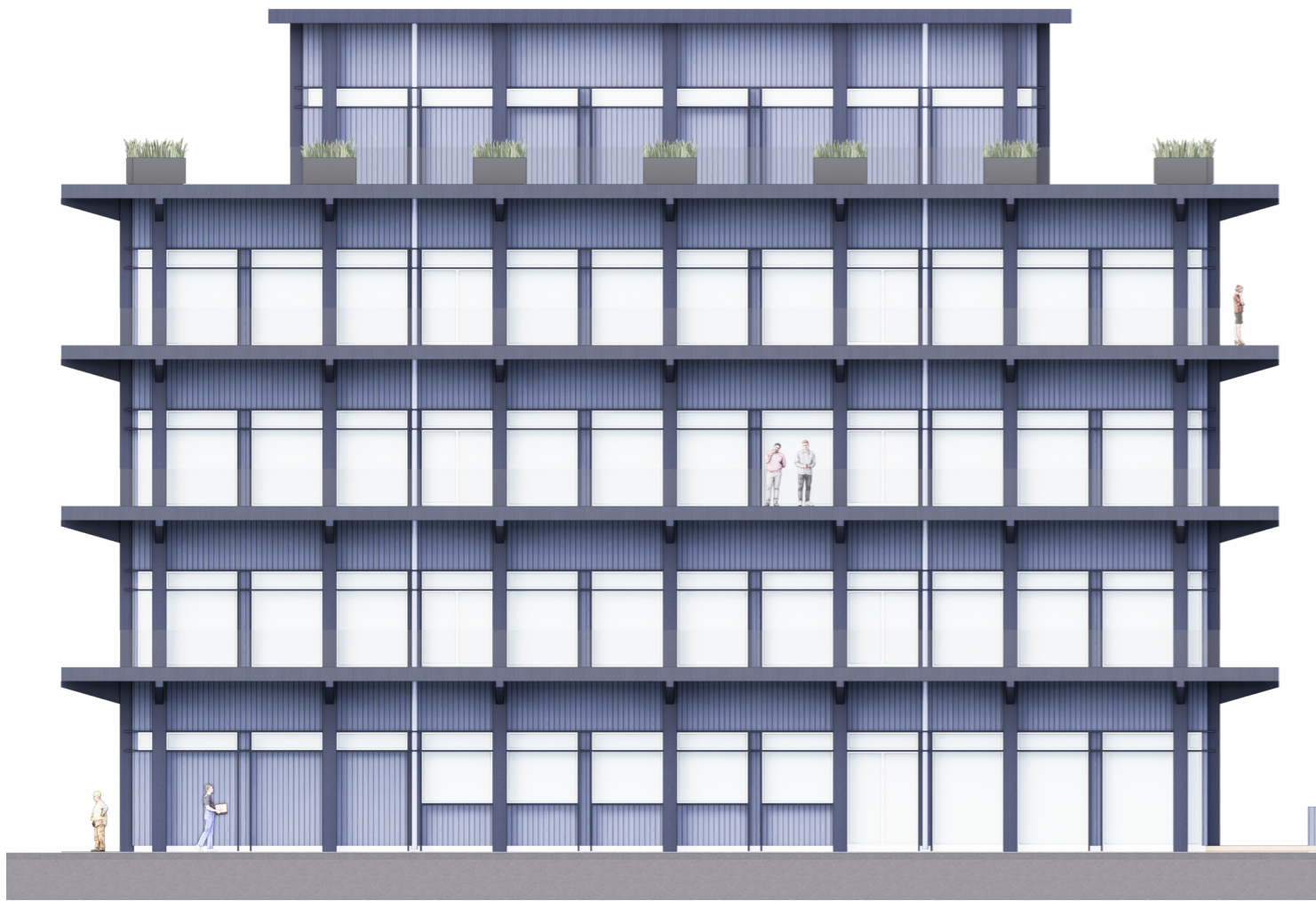

East Elevation 1:200



South Elevation 1:200

Construction

The load bearing parts is inspired by the project Habitat 7. The tectonic hierarchy and the distance between load bearing elements are inspired and produced in discussion with an structural engineer involved in Habitat 7. It uses large wooden glulam columns as the vertical structure. The horizontal structure are divided in two perpendicular glulam beams, a primary below and a secondary on top. The whole skeleton stands on a concrete slab on the ground.

On the outside of the facade there are large blue glulam columns standing on the ground. These blue columns are both design elements but also the structure to carry the balconies around the building together with blue glulam beams. This solution separates the indoor structure and the outdoor structure to reduce the risk of heating and moisture moving through the climate shell.



A picture of the load bearing tectonic structure inside Habitat 7.

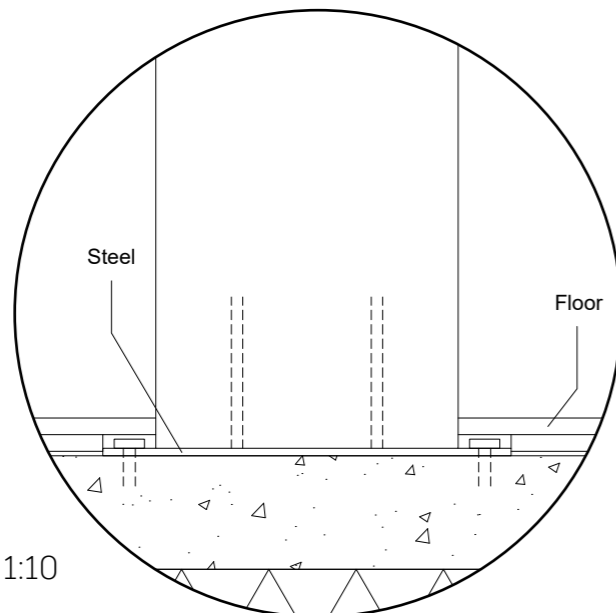

Detailed section 1:10

To reduce the risk of water damage in the wood columns, the columns are not placed directly on the concrete slab. A small steel construction is placed on the slab to separate the wood and the concrete. The steel construction is also a stabilizing solution to keep the column straight on the concrete slab which is not always horizontal. This solution also applies to the blue columns on the outside of the facade.

- 600 x 215 mm glulam beams - 800 mm apart
- 800 x 300 mm glulam beams - 4800 mm apart
- 400 x 400 mm glulam columns - 4800 mm apart

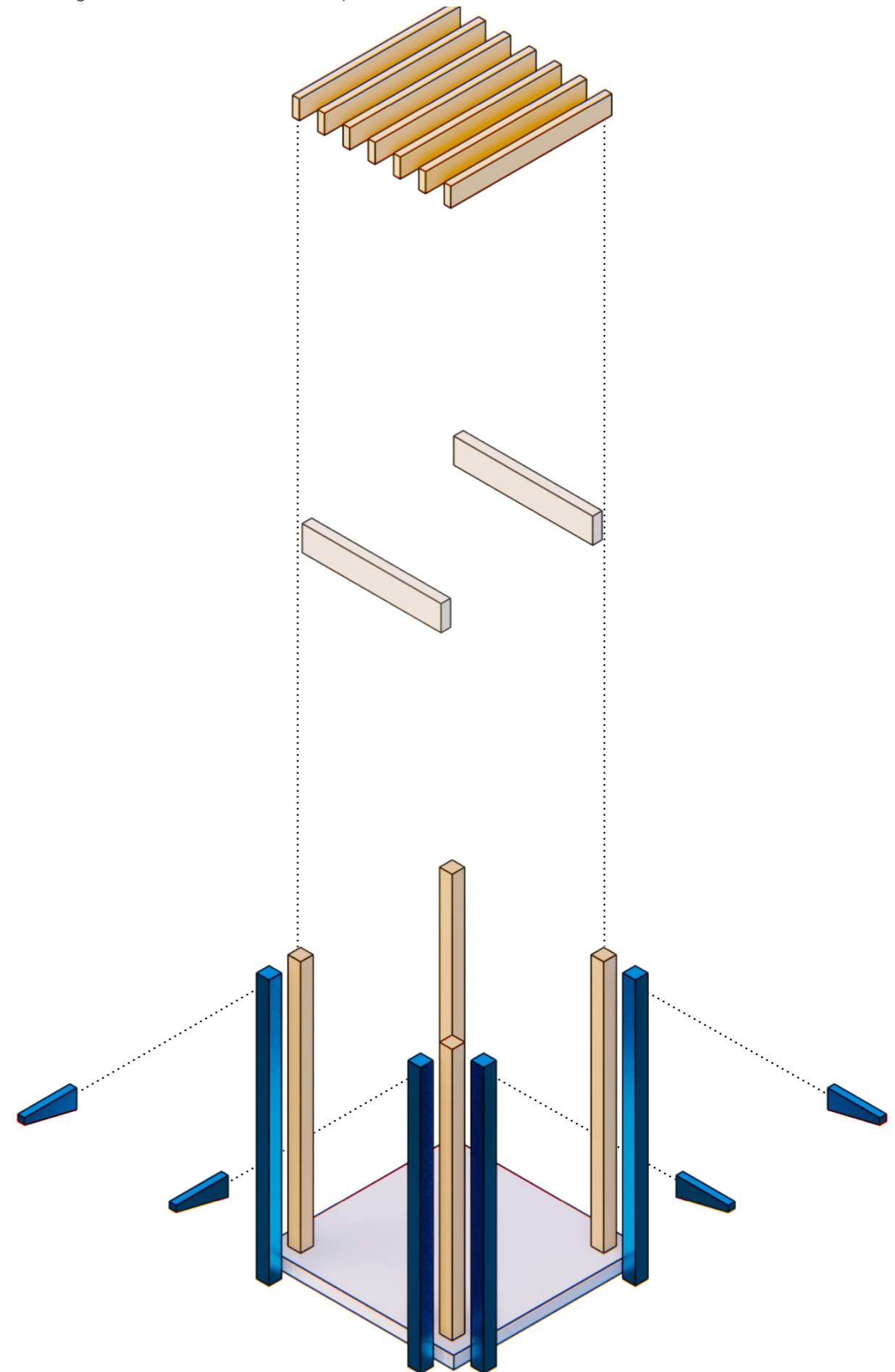

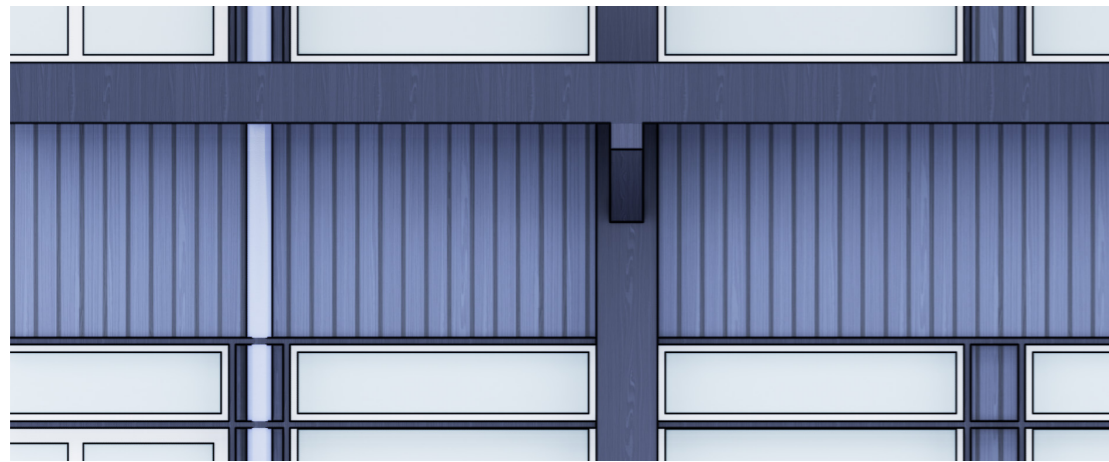

Detailed Elevation 1:50

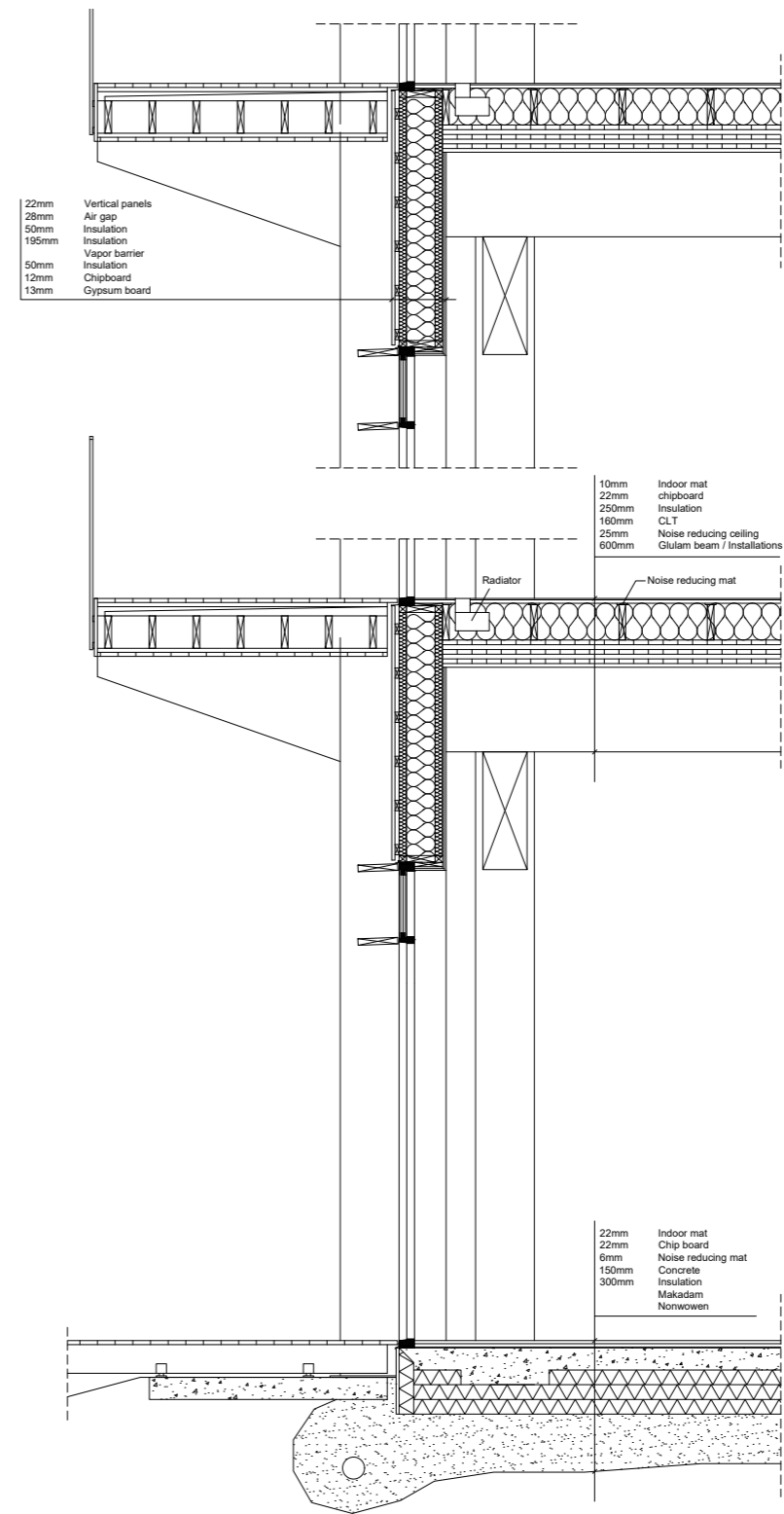

Detailed Section 1:50

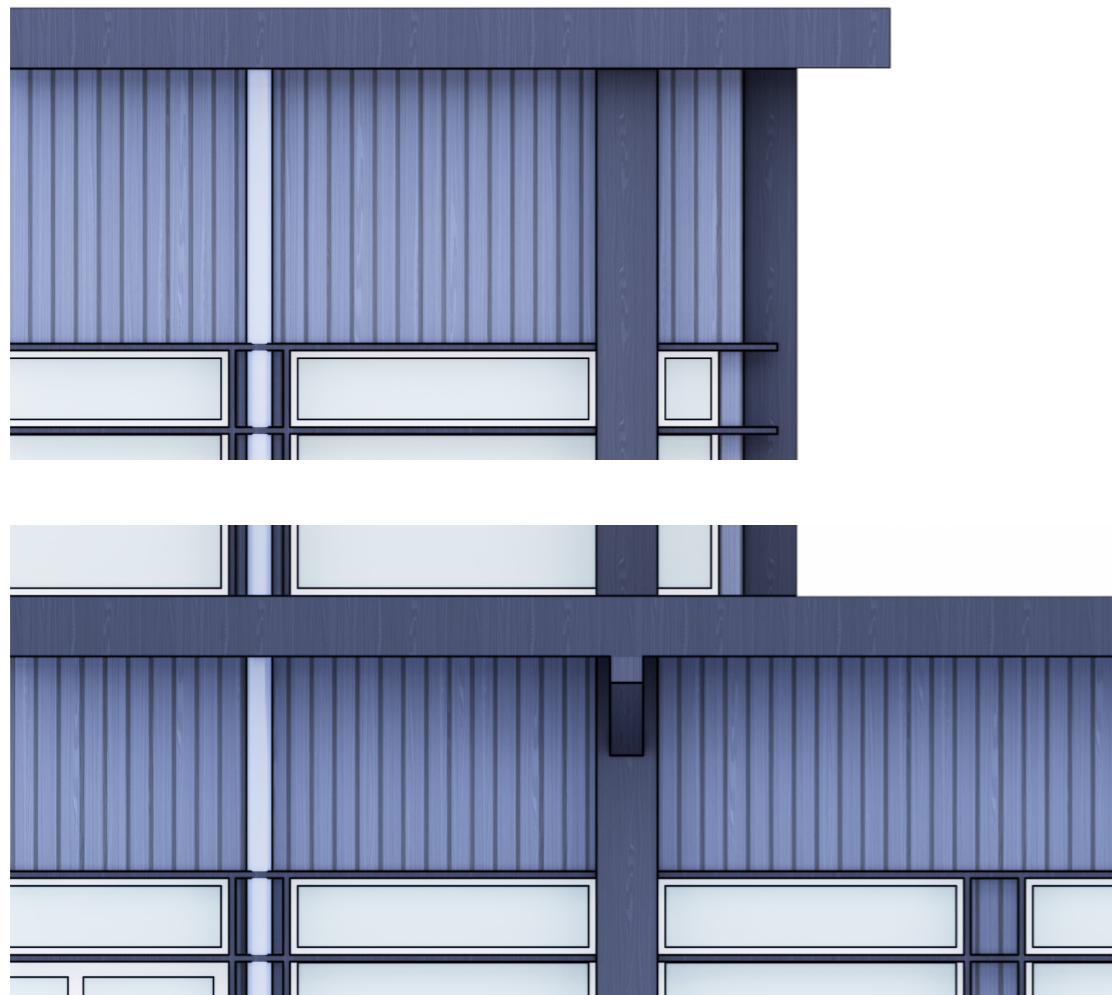

Detailed Elevation 1:50

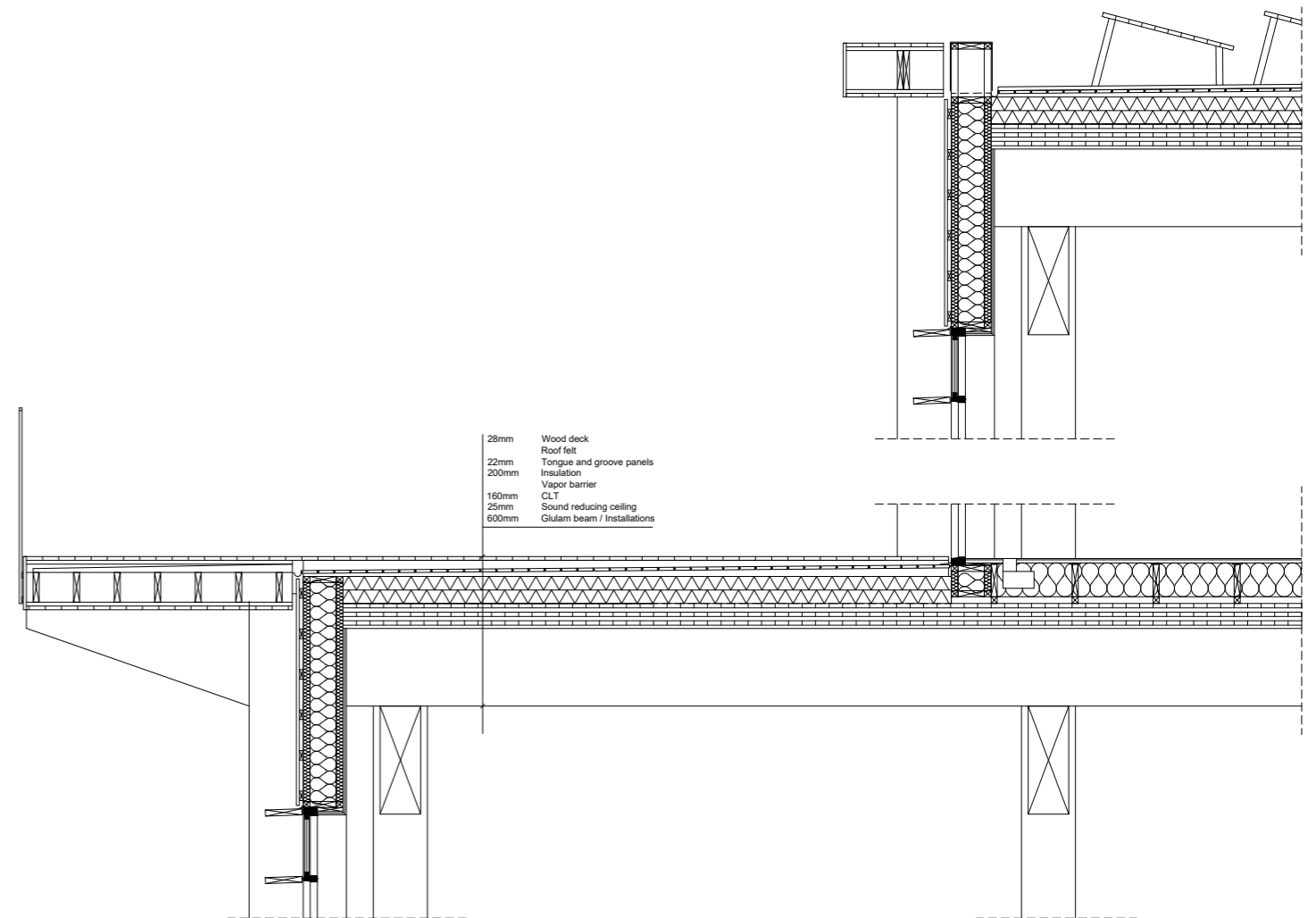

Detailed Section 1:50

Noise reduction

When comparing the weights of wood and concrete, wood is a lot lighter. This makes it so that different frequencies of sound travel differently through wood and concrete. Lower frequencies are challenging for wood to reduce. The main source for these frequencies are impact noise. One common and strategic solution when building in wood is to put a small slab of concrete on top of the wood. To reduce to lower frequencies. To achieve the same noise reduction quality by not using any concrete requires an increase in the height of the floor slab. This makes it so that impact noise does not transfer through the floor slab as easily.

Below shows two examples of the same floor but with different solutions for noise reduction. The detail on the left is very similar to Habitat 7. The detail on the right is used in this proposal.

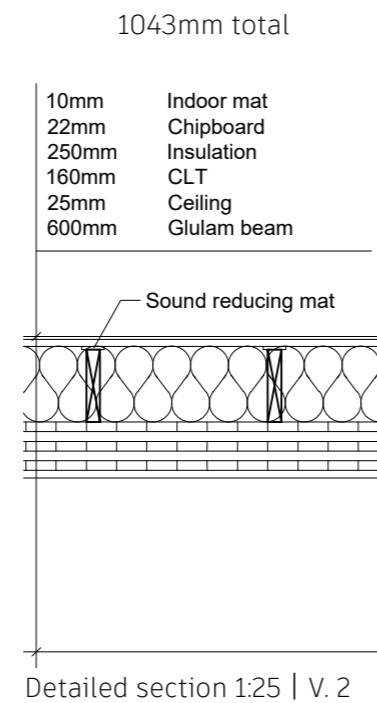
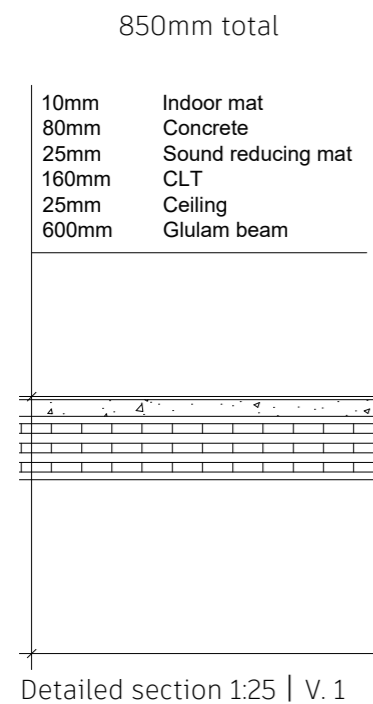

Indoor climate

A large shaft in the middle of the building spreads the ducts effortlessly around the building. The ventilation ducts are strategically placed within the structural grid to allow for efficiently change room sizes in the future, strengthening the adaptability of the proposal. The ducts are visible and used as a part of the robust design.

Below the windows inside the building there are heat radiators hidden in the floor. These radiator heats the cold air next to the windows while still being almost invisible and not taking up space.

The balconies around the building are not only a way for personal to access the sunlight but also a practical way to reduce the amount of direct sunlight into the building. The balconies provide natural shading into the office spaces reducing the overwhelming heat provided by the sun. Creating comfortable indoor areas.

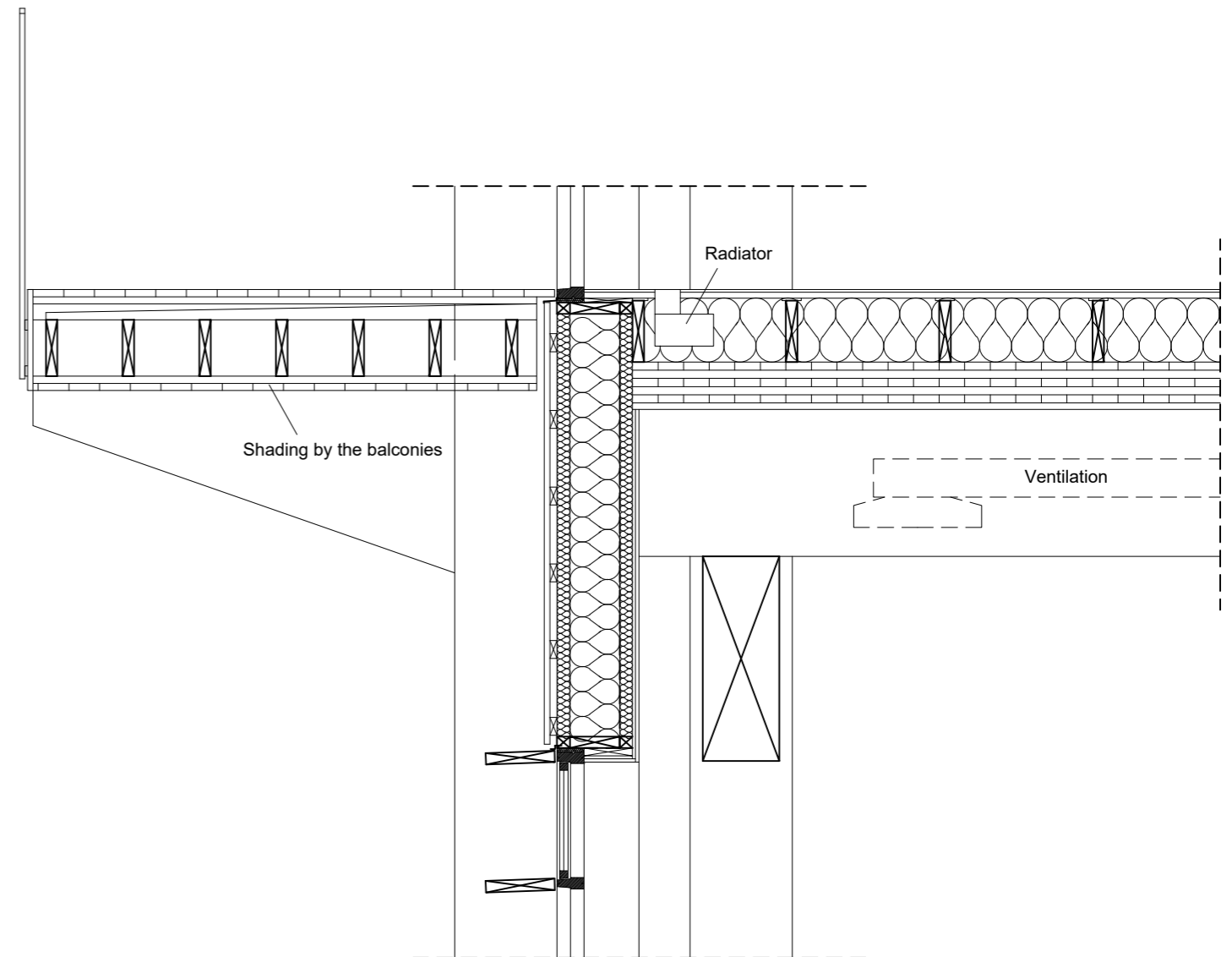

Maintenance

Together in discussion and supervision with a maintenance expert, a maintenance plan were made. The plan mainly involves washing and repainting the facades. After 30 years, there is a threshold to replace the wood panels but with the correct maintenance the life expectancy of the wood are longer.

The north and west facades face the water and are more exposed and vulnerable. This results into these facades needing more care, washed each 5 years instead of each 10 years. The wood panels of Swedish pine are painted with a water based paint for a more sustainable alternative to oil based paint. The paint works as a protective covering to shield the panels from the weather and is necessary to expand the life expectancy of the wood.

Fire resistance

Different measures have been made to achieve a robust building with regards to fire resistance. To increase the amount of time the load bearing structure can manage during a fire without losing it's structural capabilities, a special transparent paint with fire resistant qualities are used. The paint are put on every visible column and beam. To reduce the risk of fire spreading throughout the building, a sprinkler system is present in the whole building. A necessary solution when having visible wood.

To allow all personnel to escape in a emergency the centered core of the building is surrounded by extra thick walls. This measures that the staircase is safe for a long amount of time. The staircase leads directly outside on the ground floor for a quick and easy exit. The balconies surrounding the building can also be used as an escape if a fire truck with a escape ladder are present.

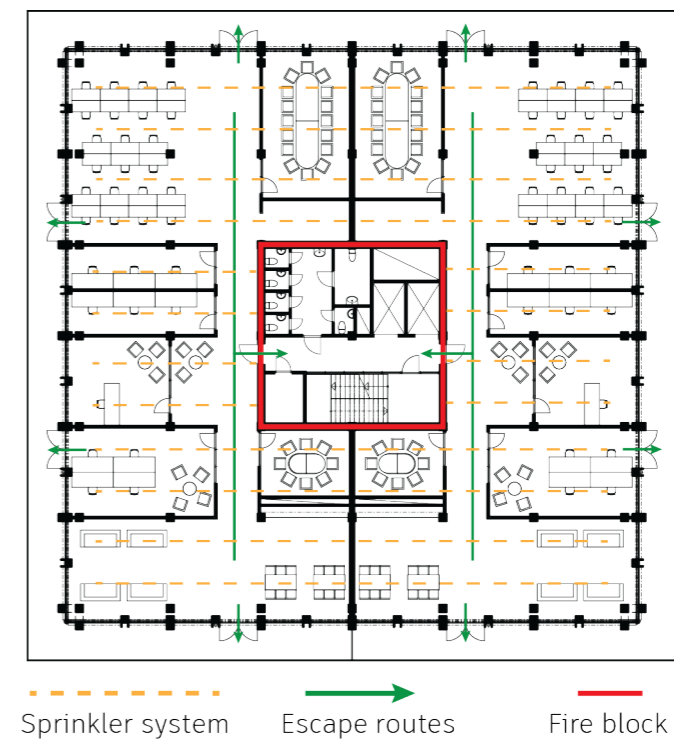
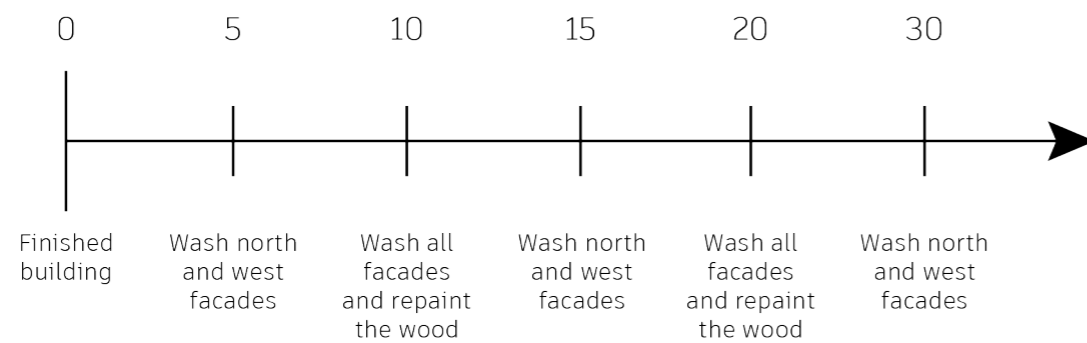

The warehouse

The warehouse, tho not focused on in this proposal, is still an important part of NOS operation. The industrial flows on the site is all connected to the warehouse. The building is divided into three main spaces to separate different forms of stored items. An important part of the warehouse is to have it in close relation to the vessel. The spaces around the structure are design with the intention of enough space for trucks to efficiently unload and rotate.

The facade of the warehouse mimics the office building to connect the two in design. It uses the same color and material. The warehouse also uses the same facade motives but leans more into the vertical elements, emphasizing the ceiling height of the roof inside. The vertical elements also fit the warehouse which is much wider building compared to the office structure, making it feel shorter.

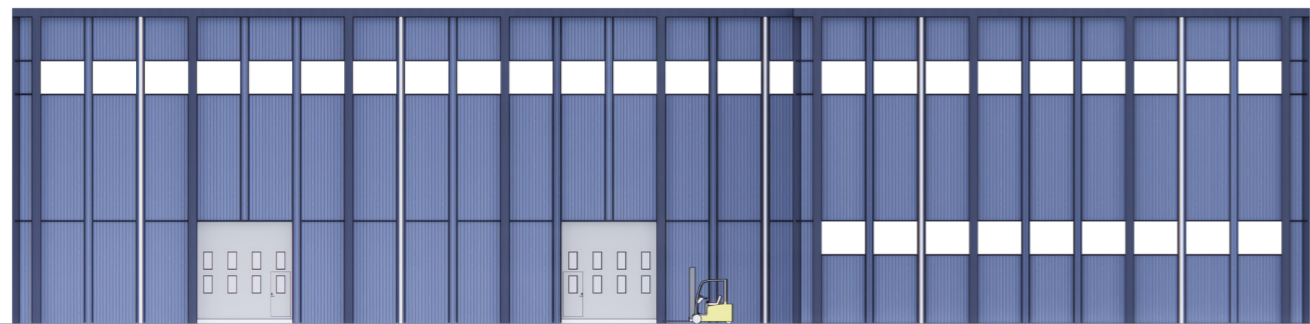

Northeast Elevation 1:200

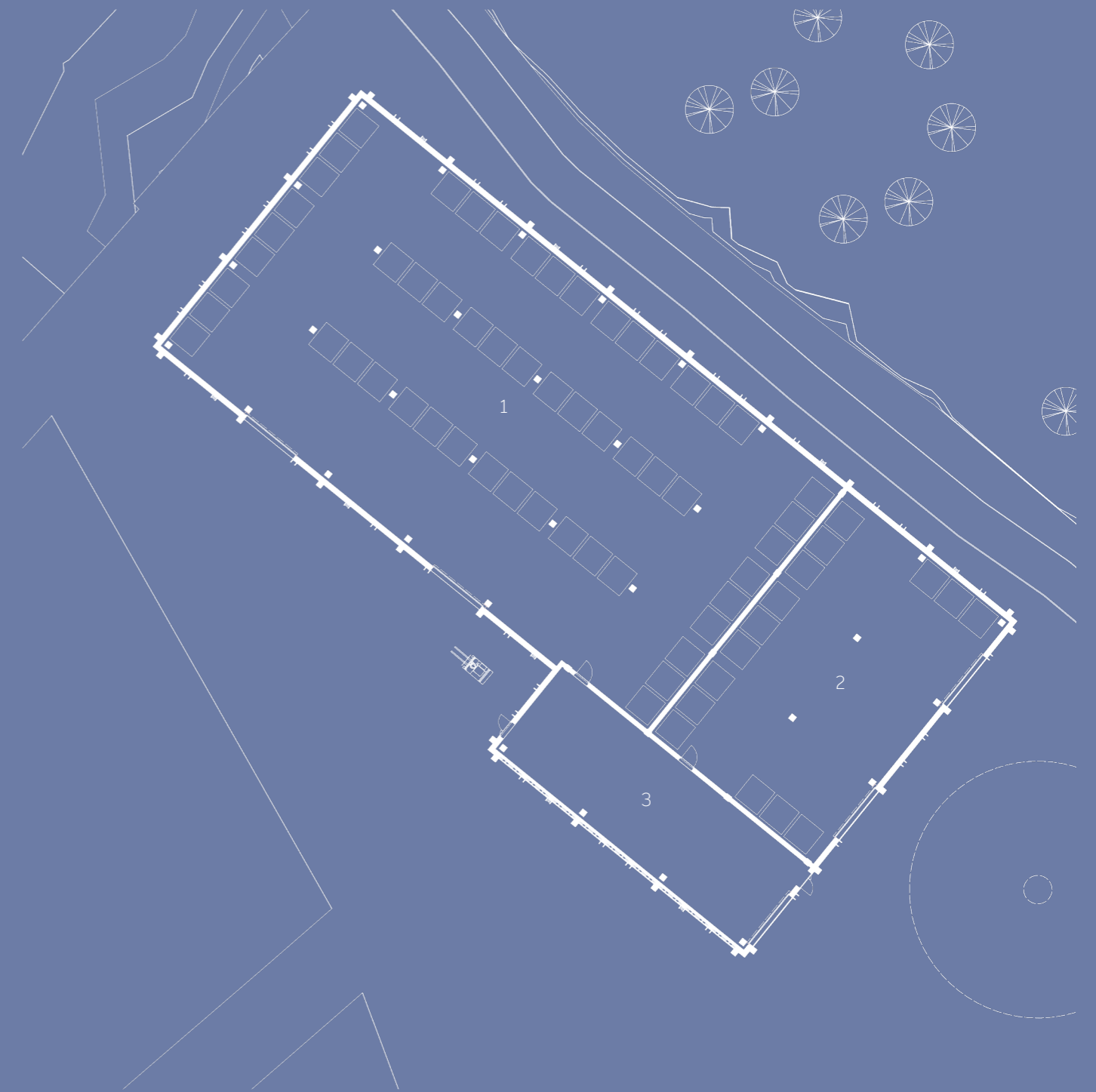

Ground floor 1:200

1. 1000 m² Warehouse
2. 300 m² Warehouse

3. 200 m² Workshop

Discussion

Discussion

An interesting analysis was made through the research of solving and designing the five areas connected to robustness. While trying to solve one area it very often impacted the other areas, both in positive and negative ways. A positive example of this is that the solving noise reduction in walls and slabs often also achieves fire resistance. And with the increased floor height in regards to noise reduction brought forward an opportunity to have the heating inside the floor. A negative example is that trying to achieve an efficient piping system for ventilation almost always creates conflict with the tectonic load bearing structure.

The challenge becomes not only solving these aspects by themselves but also solving them so they coexist within the same building. I think the way to achieving true robustness is to have them help each other to achieve even further strengths and robust qualities.

Having knowledge on how these aspects of robustness works and how they perform with wood creates the opportunity to solve the aspects simultaneously which decreases the risk of disrupting another and increases the ability to coexist and achieve a robust design.

Even if this project was made through a case study I realized that many decisions in relation to robustness were not actually impacted by the case study. Some design choices were of course impacted by the site and the brief but this makes it so that this project could achieve robust qualities no matter the location and proprietor. But it is both necessary and interesting to mention that the usage of the case study paved the way for this investigation.

Wood is a material with both strengths and weaknesses and this project shows that it is possible to use wood and achieve a robust building. It is interesting to also bring forth a discussion about aspects not included in this project in relation to other materials. Economics and efficiency are two aspects that are often very important when designing and constructing new buildings. Other materials as opposed to wood might have strengths in these aspects that wood does not. Both economics and efficiency are aspects that could be related to robustness which raises the discussion of wood against other materials. How can a robust design be achieved even further with more inclusion of other materials?

References

- Arbetsmiljöverket. (2023). **Temperatur och klimat.**
<https://www.av.se/inomhusmiljo/temperatur-och-klimat/>
- Baker, I (2021). **What's the difference between Impact and Airborne noise?**. The Soundproofing Store.
<https://www.soundproofingstore.co.uk/whats-the-difference-between-impact-and-airborne-noise>
- Brandt, K. (2014). Brandsäkert byggande. *Tidningen Trä*, 2014(2)
<https://www.svenskttra.se/publikationer-start/tidningen-tra/2014-2/brandsakert-byggande/>
- Cambridge. (n.d). Robust. Cambridge dictionary. Retrieved November 2023 from
<https://dictionary.cambridge.org/dictionary/english/robust>
- Chapman, S. (2022). **Here's Why Building Maintenance Matters for Safety and Security.** Dormakaba.
<https://go.dormakaba.com/sv/articles/heres-why-building-maintenance-matters-for-safety-and-security>
- Designer. (2015). **Relationship between Structural and Architectural Design.** Civil Engineering Projects.
<https://www.civilprojectsonline.com/building-construction/relationship-between-structural-and-architectural-design/>
- Detail. (n.d.). **Robust Architecture Low Tech Design.**
https://www.detail.de/de_en/robust-architecture-low-tech-design
- Efterklang. (n.d.). **Bra ljudmiljö på kontoret – så lyckas ni.** Arbetsplatsenfokus.
<https://arbetsplatsenfokus.se/kunskapsbank/ledning-och-organisation/bra-ljudmiljo-pa-kontoret-sa-lyckas-ni/>
- Eriksson, P. (2000). Framtidens byggmaterial har alltid funnits. *Träinformation*. 2000(2)
<chrome-extension://efaidnbmninnibpcjpcglclefindmkaj/https://www.svenskttra.se/publikationer-start/tidningen-tra/2000-2/>
- FPC Risk. (2023). **Fire Safety Concept: The Indispensable Link for Uninterrupted Business Continuity and Safety.**
<https://fpcrisk.com/news/article/fire-safety-concept-the-indispensable-link-for-uninterrupted-business-continuity-and-safety>
- Health and Safety Executive. (n.d.). **Ventilation in the workplace.**
<https://www.hse.gov.uk/ventilation/overview.htm>
- Koutsomarkos, V. (2023). **Developing a fire robustness index for the built environment.** The University of Edinburgh.
<https://doi.org/10.7488/ERA/3051>
- Maulden, R. (1986). **Tectonics in Architecture: from the Physical to the Meta-Physical.** Massachusetts Institute of Technology.
<https://dspace.mit.edu/bitstream/handle/1721.1/78804/15434951-MIT.pdf?sequence=2&isAllowed=y>
- NCC. (2023). **Habitat 7 – ett unikt kontorshus byggt i trä.** Habitat7.
<https://habitat7.se/>
- Schwarz, C. (2016). **Introducing Architectural Tectonics: Exploring the Intersection of Design and Construction.** Routledge.
https://www.researchgate.net/publication/322253651_Introducing_Architectural_Tectonics_Exploring_the_Intersection_of_Design_and_Construction#full-text
- Timberqueensland. (2018). Maintenance Benefits. **Benefits of Timber, Fact sheet (8).**
https://www.timberqueensland.com.au/Docs/Benefits%20of%20Timber/Fact%20Sheets/Factsheet_08.pdf
- White Architects. (2021). **Nodi Nya Hovås.**
<https://whitearkitekter.com/se/projekt/nodi-nya-hovas/>

Special thanks

Filip Rem - Supervisor

David Kristensson - Northern Offshore Services

Joakim Hansson - Architect from White Architects involved with Nodi

Linda Cusumano - Structural engineer from NCC involved with Habitat 7

Stanley Arevalo Monge - Maintenance expert

Torbjörn Lindholm - Indoor climate expert

