

TEXTILES

A material exploration of hybrids of
textiles and wood in architecture

Examiner: Daniel Norell
Supervisor: Malgorzata Zboinska
Chalmers School of Architecture,
Department of Architecture and Civil Engineering



CHALMERS

TEXTILE WOOD

Master thesis 2021

Emma Olsson

Chalmers School of Architecture,
Department of Architecture and Civil
Engineering

Examiner: Daniel Norell

Supervisor: Malgorzata Zboinska

Master program in Architecture and
Urban design

ABSTRACT

Textiles and wood have always been important materials in humans built environment. These materials were optimal for us to use in tent constructions in nomadic times, tents that can date back to the early human times. But as the world evolved so did architecture and during the last millenniums textiles have been changed to more static materials like stone, brick, or concrete.

Today in architecture one can most often find textiles as thin membranes to lightweight constructions. In combination with steel, they can create and cover complex forms. The purpose of the thesis is to challenge the idea of how textiles are used as a material in architecture as well as broaden the use of its techniques with wood as a tool. The techniques used stems from current applications of textiles in architecture as well as other fields where textiles are used widely.

The aim and goal of this exploration is to create architectural hybrids of wood and textiles which can be used as architectural materials. This thesis starts by exploring and experiment with textiles and wood to create hybrids between the two materials to be used in architecture. It will investigate its material qualities and how these can be transformed by exploring different techniques. The project will continue by further exploration to create architectural qualities and use cases.

Furthermore this thesis is a process of developing and testing different techniques and methods by using both physical and digital tools. This will be done by working mainly with physical exploration and model making with a compliment of drawings and 3D modelling.

Eight different hybrids of various types of wood and textiles are the result of the studies and exploration. These hybrids are applied in architectural settings and will be exhibited as a catalogue of architectural elements. The results are showcasing a wide variety of qualities and expressions which implies that the uses of the combination of wood and textiles could have a wider implementation in architecture than it has today.

*'The cutting edge in architecture is not sharp,
but sensuous and soft.'*

- Bradley Quinn

CONTENT

| | |
|-------------------------------------|-----------|
| Introduction | 7 |
| Purpose | 8 |
| Aim | 9 |
| Research questions | 9 |
| Methods and process | 10 |
| Delimitations | 12 |
| Reading instructions | 13 |
| Dictionary | 13 |
| Authors background | 14 |
| Thesis theme motivation | 15 |
| Theoretical background | 17 |
| Textiles | 18 |
| Textiles In architecture | 20 |
| Textiles and Wood | 24 |
| Material exploration | 27 |
| Experiments | 29 |
| Mapping and categorizing | 31 |
| Hybrid systems | 35 |
| Architectural Implementation | 45 |
| Façades | 47 |
| Space dividers | 64 |
| Conclusion | 75 |
| Conclusion and discussion | 76 |
| References | 80 |



INTRODUCTION

PURPOSE

Today textiles are often used in one way in architecture, as a lightweight membrane that can work as a protection in complex forms created by steel or aluminium. The purpose of this thesis is to showcase other ways of using textiles in architecture. With this thesis I want to explore textile in combination with wood to try out different techniques and learn more about the two materials together.

By combining different textile and wooden techniques in a way to explore new ways textiles can be used in architecture I hope to shed light on new and different ways to incorporate textiles in architectural design.

AIM

The aim is to showcase different ways of using textiles in architecture by looking in to how it can be combined with wood to form hybrid material system that can be applicable in architectural design. By looking at different ways of using textiles than the traditional ways of lightweight membranes I aim to emphasize unique qualities not present in standard application of textiles as tensile membranes.

By creating hybrids of textiles and wood in architecture the aim is to investigate how the two materials can be combined to be used as materials in construction and an architectural setting. The end result will be a catalogue to show the different systems of textile/wood hybrids. These will be shown as architectural elements with an aim to explore architectural context where the hybrids could be used.

RESEARCH QUESTIONS

-In what ways can textiles and wood be combined to form hybrid material systems?

-Which specific qualities do these hybrid systems bring into the architectural expression?

METHODS AND PROCESS

This thesis is built on material and design studies which will be implemented in an architectural context. The process will contain of parallel research which will be both material exploration and theoretical research. The final result of the thesis-work aims to contribute to a larger understanding of textile materials in architectural uses and scale.

This process will be driven by working with different techniques to manipulate the materials testing a variety of ways and systems of combining them.

MATERIAL EXPLORATION

This thesis will be a material study which will be based on research, collecting references and trying methods and techniques out using digital tools and physical tools.

Physical modelling

To test out different textile and wooden techniques I will mainly work with physical testing and modelling. To try out different techniques and try them in architectural forms. The first step in this is to try out different hybrids that can be developed further to create systems that can be used in architecture.

Digital modeling

To complement the physical modelling I will work with digital tools. To 3D model the physical tests and test them in architectural settings will be done in Rhinoceros and Grasshopper as well as work with collaging and digital sketching. This will be done to do mock-ups in bigger scale as well as testing out the techniques in different ways.

Theoretical research and case studies

In parallel to the design research I will collect references and read up on material properties and qualities. I will do theoretical research by looking in to the process of textile architecture and built examples. There will also be an in-depth look in to the use of textile in buildings as well as other uses that can be linked to our use of architecture. In parallel the more hands on material studies will begin using both digital and physical tools.

DESIGN RESULT

Hybrids

From the test and research textile and wooden hybrids will be developed. They will be showcased by systematic drawings and informational text. These will then be implemented as architectural element as a final design result.

Architectural implementation

The final design result of this thesis will be a catalogue of design implementations of the systems that has been developed with the hybrids of textiles and wood. These will be showcased in architectural drawings, illustrations and physical models.

The aim of the architectural implementation is to showcase different systems and techniques of using textiles and wood. The aim is not to find the perfect hybrid but to showcase a variety of application possibilities

DELIMITATIONS

This thesis aims to be an artistic and architectural experimentation with a focus on expression and functions. It will not dive deep in physical performance or textile technology but will be made out from a general knowledge of properties of textiles today.

It will not go in to specific textiles nor smart textiles but will work with general textiles and textile techniques.

The aim of the thesis is not to find the perfect way of combining textiles and wood in architecture but aims to try different methods and showcase a variety of techniques.

READING INSTRUCTIONS

The thesis is divided in four parts where the first is **theoretical background** to set the base of the thesis with a background on textiles and how it has been used in architecture and together with wood. The second part is the **material exploration** where material tests and case studies are shown. This part ends with the systems of hybrids that have been developed in the exploration. The third part is the **architectural implementation** where the hybrids are exhibited as different architectural elements. Lastly the thesis and the work is concluded.

DICTIONARY

Fabric- when using only the word fabric in this thesis this will refer to a woven fabric if not this will be stated.

Architectural elements- the phrase architectural elements are used as an umbrella term to describe components in architecture such as wall, staircase, floor etc

Textile techniques - techniques typically used within textile fabrication and crafts.

AUTHOR

EMMA OLSSON

Msc. Architecture and Urban design

Chalmers University of Technology

2019-2021

- Architecture and Urban space design
- Material and Detail
- Material models in architecture
- Sustainable development and the design professions
- Architectural competitions
- Master thesis preparation course 1 & 2

Erasmus exchange program

École nationale supérieure d'architecture de Paris-La Villette

Spring 2020

- Public Building
- Rehabilitation/interventions in ancient buildings
- Construction in wood, detail and construction
- Social Housing in France (1850-2014)
- Philosophy of the image and digital transition: perspectives on architectural representations
- BIM for the project

Bachelor program in Architecture

Chalmers University of Technology

2016-2019

Other studies

Clothing and design

Umeå universitet

Autumn 2015

Contact:

emmaldolsson@gmail.com

+46(0) 727186138

THESIS THEME MOTIVATION

I have always been interested in textile materials and its uses. Prior to my architecture studies I have studied clothing design and sewing as well as I do a lot of textile crafts in my spare time. However I have never really found an interest in textile architecture and that is because I find that textile materiality and techniques is often overlooked. With this thesis I want to investigate more of the wide variety of textile techniques that I find interesting as architectural materials and in an architectural setting. With a hope of learning how to work with textile in architecture and broaden its use.

As most students at Chalmers I have started my architecture studies by looking at wooden construction starting with basic structures and classical use of the material in building. My interest for wood has followed me in later years where I have chosen courses and studios to broaden my view on what wood and wooden construction is. I want this thesis to continue that process.

The combination of textiles and wood is not something common in architecture so with this thesis I hope to work as a starting ground for me to incorporate the two materials in my architecture. I also hope that this can inspire other architects to use textiles and wood in their work.



THEORETICAL BACKGROUND

TEXTILES - IN ARCHITECTURE, WITH WOOD

A theoretical base of the thesis that goes in to textile qualities, how its been used and discussed in architecture and how textiles and wood have been combined.

TEXTILES

Textiles is something every human has a reference to. We live surrounded by it, you are probably wrapped in clothing now, maybe sitting on a chair covered by fabric. But in architecture the references aren't that many or that strong.

Textile is a term of materials created by textile fibres. Textile fibres are either **natural fibres**, like cotton, flax, wool or silk, or **synthetic fibres** such as polyester, nylon, viscose or carbon fibres. Normally textile fibres are spun to threads or yarn that can be woven or knitted in to a fabric. There are also so called *non woven fabrics*, like felt, that doesn't consist of threads but fibres pressed together. (Nationalensyklopedin 2021).

Knitted fabric is made by continually connecting loops of yarn or thread in to a flexible, elastic fabric. This fabric is used mainly as a material for clothing but has gotten more popular in interior and furniture making as well as medical and technical textiles (Nationalensyklopedin 2021).

Woven fabrics are stronger, more stable and less stretchable than a knitted fabric. Woven fabrics is the most common fabric and is used as clothing, home textiles and as more durable fabrics on furnitures. A weave is created by having a system of parallel threads which are separate to insert one or multiple crossing threads (Nationalensyklopedin 2021).

One of the key strengths of textiles is its flexibility. Not only is this beneficial in clothing and interior design but also in architecture. Textiles are for example used in tents, small tents for camping or huge tents for circuses or temporary fairs. They share the need for its flexibility in foldability. To be able to carry your home in your backpack or a cover for a football field in a truck.

That a material is soft and pliable is often not the most wanted qualities in architecture where stronger materials like concrete, steel or wood are preferred. But as Pennina Barnett describes it: *"an object that gives in is actually stronger than one that resists because it also permits the opportunity to be oneself in a new way"* (p.183) its softness is its strength (Hemmings, 2012).

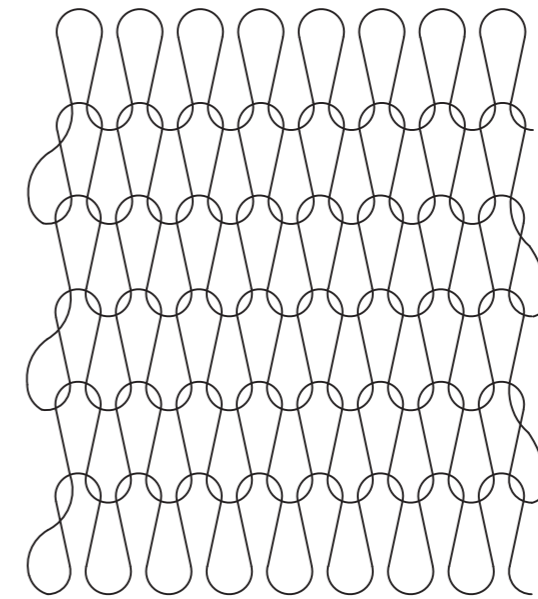

Knit

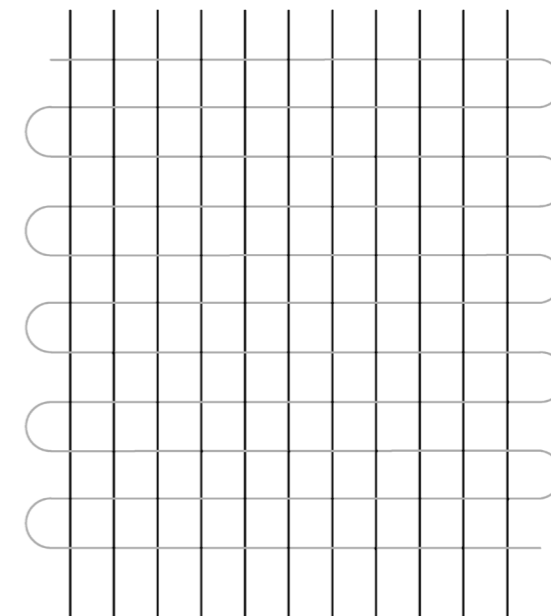

Weave

TEXTILES IN ARCHITECTURE

Textile history is a bit unclear as textile material easily disintegrate and has also long been overlooked by archaeologists. But in more recent years textile fibres, as well as tools such as needles, have been found that dates back approximately 35000 years (St Clair, 2018). However tent-like nomadic constructions made from skins, a material that shares a lot of qualities with textiles, dates back 150 000 years (Kronenburg, 2014).

Since then more static materials such as stone, wood and steel has taken over as the main materials in architecture but textiles has always played a vital role in architecture and space making.

According to nineteenth century theorist Gottfried Semper the original form of walls or enclosures are weaves, either wickerwork as fences or woven wall hangings as space dividers. He describes wall hangings as the true walls, that *“The often solid walls behind them were necessary for reasons that had nothing to do with the creation of space”* (Semper, 2010, p.104).

As textile research and technology goes forward the use for textiles as materials for architecture broadens. In 1851 Semper writes *“precaution should be taken for its exterior preservation”* (p.126, 2010) as textiles in the mid 19th century did not stand the test of the environment as synthetic textiles of today do.

In contemporary architecture textiles is often used outside as a lightweight membrane material as coverings in complex structures. You can see it as roofs in stadiums, as second skin façades or as a protective layer in a lightweight construction. Frei Otto pioneered this use of textiles in architecture in mid to late 20th century with works of tensile structures. An early example of this is the German pavilion at Expo 67 which gave him his international break trough (Pitzker prize, N.D).

The textiles mainly used for these membranes today are made up of coated polyester or glass fibre fabrics, or flouropolymers such as PTFE or EFTE. These materials are high strength and weather resistant. They are light weight and can be as thin as 0.05 millimetres (Peters, 2011).

The use of textiles as membranes are restrictive in the form the material can take. It limits the textiles to primarily be quadric, anticlastic surfaces such as hyperbolic paraboloids. They are most often designed to be static and stretched so that the material is virtually stiff (Hörteborn, Zboinska, 2021).



Image 1: Wildscreen World at Bristol, Dennis Gilbert

Textiles are used in other ways than tensile membranes as well, but not to a large extent. For the purpose of case studies relevant for addressing the questions of this thesis, four projects that explored alternative geometric shaping of textiles were selected and analysed more closely, from the standpoint of three aspects: formal expression, way of textile mounting to the load bearing structure, and function. These projects are discussed below.

We Hotel Toya- Kengo Kuma and associates

A nursing home transformed to a boutique hotel using wood and fabric. The hotel shows a lot of different ways of using textiles to create and form spaces. The restaurant in the hotel is shaped by pleated fabric that is hung by frames from the ceiling and draped around pillars. The material expression is strong with the pleated fabric and the function of the fabric is to create a cosier atmosphere .

Weird sensation feels good - ÈTER

Boxen at ArkDes museum in Stockholm was host for an ASMR exhibition in 2020. The walls are merged with the floor by being covered in a 1km long white pillow where you can sit or lay to view the exhibition. The pillow resembles intestines or folds of the brain and is attached to a substructure placed along the walls of the exhibition space. The environment is created to be soft and comfortable to enjoy the ASMR videos.

Fabric room - Tord Boontje

The fabric room is a room within in a room created by draping fabric hung from the ceiling around glass walls, doors and an elevated wooden floor. The fabric is attached to wooden plates that are wired to the ceiling with hanging points spaced out to control the form of the room. A temporary solution to create a meeting room in a large industrial working space. The heavy draped fabric gives the room a soft but heavy expression.

Aichinger House - Hertl architekten

When renovated in 2007 Aichinger house got a new textile exterior. A white fabric draped over the house with possible openings for windows and doors. The fabric hangs between curtain rods placed on the top and bottom of the façade. It is a building with strong textile expression where the textile softens the look of the black solitaire of building.



Weird sensation feels good, ArkDes 2020

TEXTILES AND WOOD

In contrary to textiles, wood is used broadly within architecture. In Sweden wood has been used as the main material for dwellings for as long as people have been building and living in houses. But the last decades the evolution of wooden construction has evolved and it is a very versatile material that can take on a lot of different tasks.

Wood has the last couple of years often been called the future of architecture. As the world strives to become more sustainable it has started a movement to change out fossil materials in construction to non fossil materials. This has sparked a wider interest in the material and a lot of research and development has been done.

A field where we often see the two materials combine is in furniture design, where the wood creates the structure and textiles are used for comfort. From foldable deckchairs, to luxurious sofas both textiles and wood are often key elements.

Textiles in architecture are most commonly used together with metals, another material that can be quite lightweight. There are of course some built architectural works that combine wood and textiles.

The Japanese architect Kengo Kuma often integrates textile in his wooden constructions, both as a material but mainly with the technique of weaving. He said in relation to his exhibition A lab for materials at Tokyo station gallery in 2018 that weaving with wood and bamboo is common in traditional Japanese architecture and that *“Weaving makes buildings more like our clothes – soft, light and fluid”* (Interaction Green, 2018).



Image 2: Pavillion by Kengo Kuma using wood and flouropolymer membrane.(準建築人手札網站 Forgemind ArchiMedia, 2015)



MATERIAL EXPLORATION

PHYSICAL TESTING, HYBRID SYSTEMS

Physical testing of textiles and wood in combination with case studies of textile projects to create systems of material hybrids to be explored in architecture.

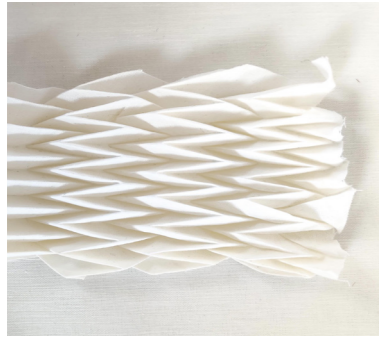

1. Pleating flat



2. Integrated knit



3. Excessive knit

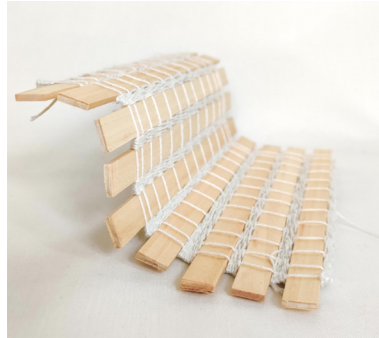

4. Wood weave



5 Ruched fabric



6. Wood knit



7. Roll up



8 Flexible wood



9. Pleated vault



10. Knit together



11. Triangles



12. Soft wood

EXPERIMENTS

To commence the development of material hybrids I started doing tests of combining textiles and wood. With these samples I wanted to explore qualities of textile that isn't commonly looked in to in architecture but also on ways of which the two materials could benefit from each others qualities. The test should exhibit other qualities than the ones found in lightweight membrane use of textiles in architecture.

The tests are made for three different reasons, to give more dimension and weight to the fabric, to make the wood mimic textile technique or/and to let the materials benefit from each others qualities.

I have done some samples to be heavier and more three dimensional, with an excessive amount of fabric. By pleating, ruching or knitting excessively the textile it self gets more dimensions. This gives the textile another expression but can also add some structural stability to the fabric. For example *Pleated vault* where the pleats make the fabric stand for it self.

By weaving or knitting with yarn and wood the two wood has taken the form of the thread but with its more structural stability. When wood mimics the textile it creates a strong textile expression as seen in *Wood knit* where the wood creates the loops of a knit.

When interlinking the two different materials they benefits from each others qualities. The wood assists the textile with stability and gains flexibility from it. Looking at for example *Triangles* and *Roll up* the hybrids two sides possesses the two materials different qualities. Fluidness and foldability in one and stiffness and stability in the other.

Fabric

Wooden sticks

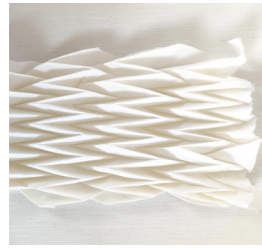

Lasercut plywood



Thread

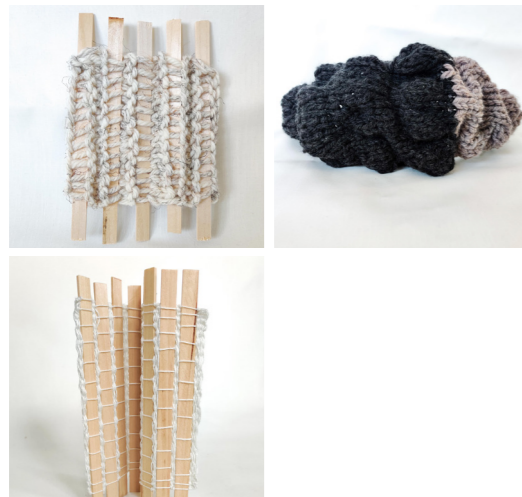

Diagram of materials in the hybrid experiments.

MAPPING AND CATEGORIZING

I have categorized and mapped the test in regards to the questions answered in previous pages. By doing this I hope to find new ways to evolve these tests to architectural design components.

The material tests are evaluated by looking at technical and aesthetic aspects. The evaluation is done by answering questions about *which materials are used, how the wood and textiles are connected, what the main qualities of the test are and how the test can be scaled up and evolved.* The evaluations are made to be a foundation for mapping and categorization of the tests.

The test are mapped and categorized based on its materials, connections and flexibility. On page 32 a diagram on which type of wood and textile techniques are used is shown. The tests are categorized by how integrated and connected the materials are on page 33. A ranking of the tests based on its flexibility are showcased on page 34.

These are steps done to find new ways to evolve these tests to architectural design components. By finding similarities and differences the tests will be developed and combined to create systems of hybrids.

CONNECTIONS



Interlinked
In these three the wood and the textiles are continually interlinked. In Wood knit the wood is formed to mimic the thread and in Wood weave and Integrated knit the wood is merged in to the textile.



Semi interlinked
Bent wood Excessive knit and Knit together are interlinked in the edges. Bent wood extensive knit has the wood knitted in but only in the edges. Knit together the wood and the thread is connected by wholes in the wood where the knit connects to.



On top
These four are less merged than the other. In two of the examples, Triangles and Rollup, the wood and textiles are glued together and the other two, Ruching and Soft wood, The wood is sewn in to the textile.

FLEXIBILITY AND MOVEABILITY

One of the qualities that I find most interesting and important with textiles is that it is flexible enough to be folded and transported easily, like a tent.

Here the test are listed from most flexible and foldable to the least flexible and foldable.

Most flexible



Pleated vault
This is the most flexible due to the fact that there is no wood added yet.



Triangles
This is completely foldable in one direction but this can vary so it can take a bit of different shapes.



Wood knit
The wood in Wood knit is a bit bendable and the thread is very soft.

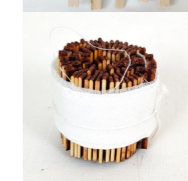

Wood weave, Wood knit and Roll up is quite similar. They are flexible in the direction of textiles but stiff in the direction of the wood. They are ordered in the order of which has the most flexibility in the textile.



Knit together
The wood in Knit together is stiff and the thread is soft. But as this has more of a 3dimensionality it s harder to fold



Soft wood
The wood in Soft wood is laser cut to be flexible but is still stiff.



Excessive knit
The bent wood is quite stiff and the sticks can be a bit pushed together otherwise stiff. The textile is soft.



Ruched Fabric
Here the fabric is placed on top of a wooden slab. This makes the combination completely stiff.

Least flexible

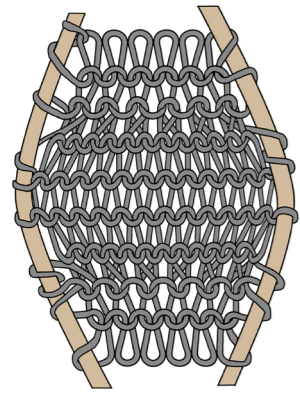

Excessive knit

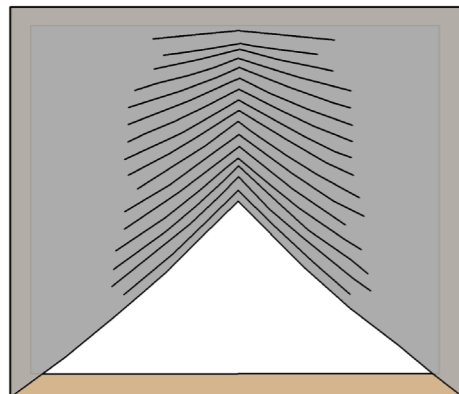

Ruched on wood

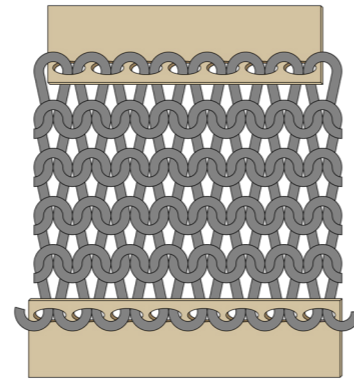

Knit and wood

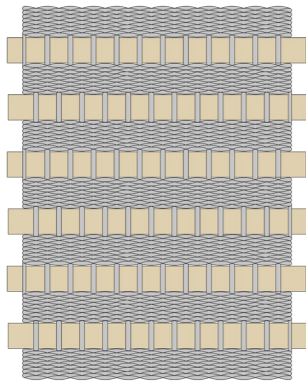

Wood weave

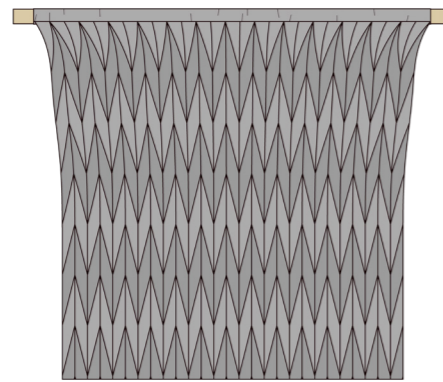

Pleating with wood sewn in

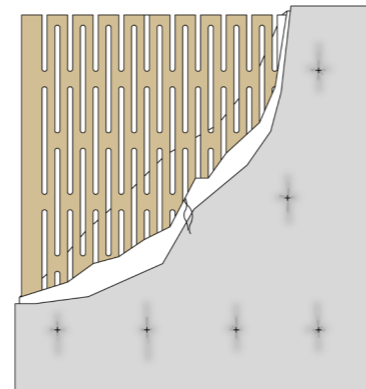

Softened wood

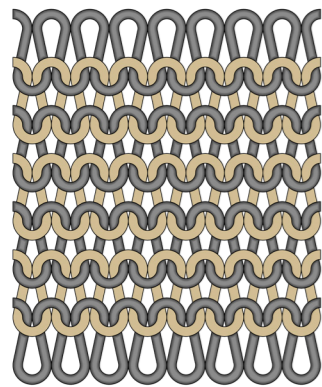

Knitted wood

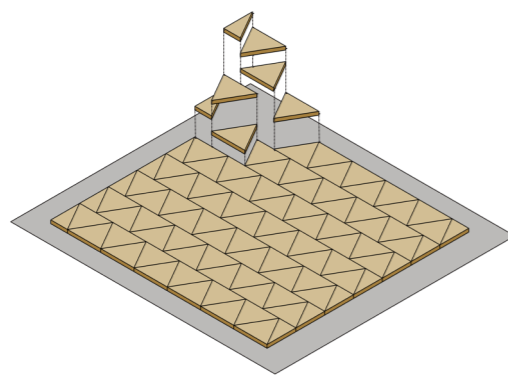

Wood on fabric

HYBRID SYSTEMS

Eight hybrid systems have been developed after evaluating, evolving, and combining the material tests. The hybrids are created to exhibit different wooden and textile material qualities. By displaying the materials in different ways they aim to create different architectural qualities and expressions. With a focus on showcasing multiple ways of using textile materials the hybrids uses different techniques, materials and scales.

Working with woven and knitted fabric as well as yarns and thread the textiles are showcased and used in different ways. Combining the different textiles with different types of wood the hybrids are showcasing a variety of qualities, expressions, and functions.

As the hybrid systems stems from the purpose of using textiles in other ways than the conventional membrane structures it is normally used as today. Therefore, the qualities of the hybrids in this thesis varies from the lightweight uses of today to incorporating more volume, weight, and flexibility. Furthermore, different techniques used in the process will be showcased.

On the following pages the hybrid systems are shown with a focus on how the materials are connected, its flexibility, and its expression. The materials and techniques used in the hybrid is described and shown.

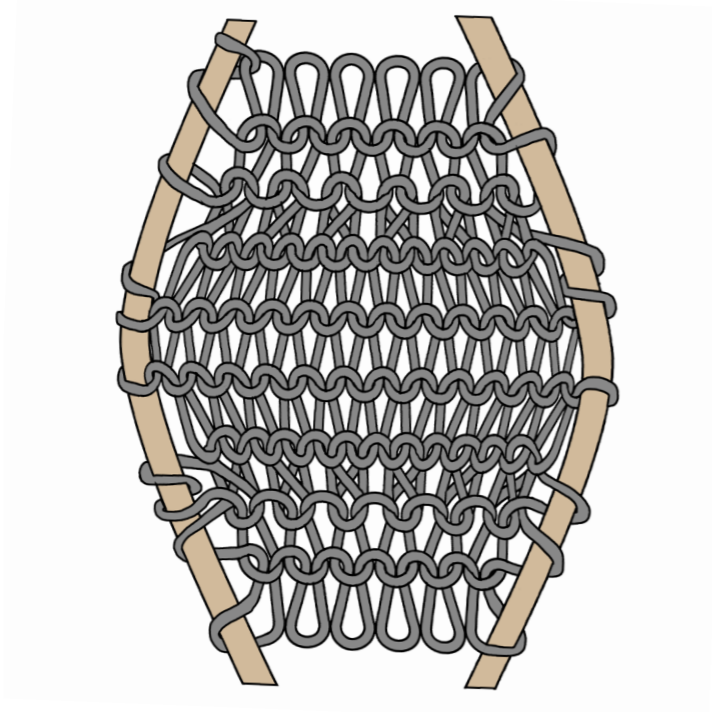

EXCESSIVE KNIT INTEGRATED WOOD

Type of textile

Yarn

Type of wood

Wooden stick or planks

Flexibility



Connection textile and wood

The wood is sewn in.

Weight



Wood knitted together by an excessive amount of thread. The materials are connected by looping the yarn around the wood in the knit.

The knitted fabric is created with a varying amount of loops in the knit, more loops equals more volume in the fabric. This is to create a three dimensional soft look.

The hybrid is semi flexible as the knitted textile is very flexible and the wood gives the hybrid stability. Depending on how the wood is structured the hybrid could be more or less flexible. This makes it possible to tailor-make the flexibility to the current use case

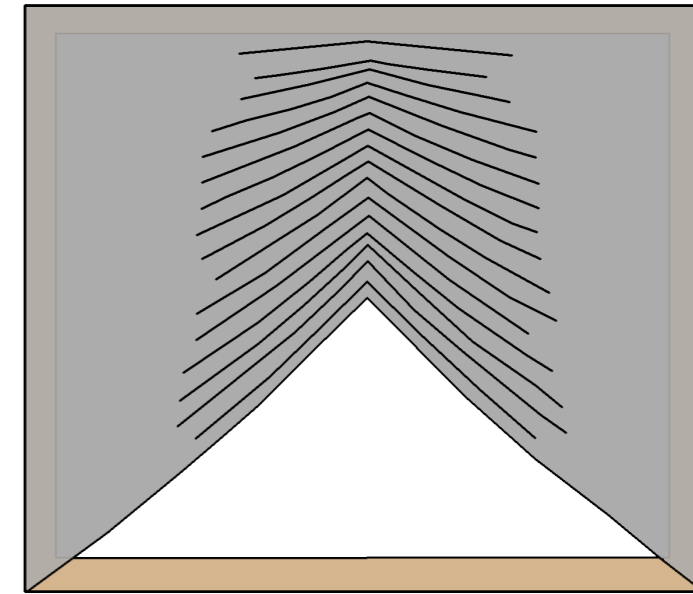

RUCHED ON WOOD

Fabric is sewn around three sides of a wooden rectangle. The fourth side is open and in the middle of the fabric two strings are sewn in to make the ruching.

The textile is flexible and can be opened and closed but the frame is static. By having a larger piece of fabric and/or a stretchable fabric the ruching can open up more.

The ruching creates texture to the fabric and gives it a gathered expression when pulled together.

Type of textile

Fabric

Type of wood

Wooden frame

Flexibility



Connection textile and wood

The wood is sewn in.

Weight



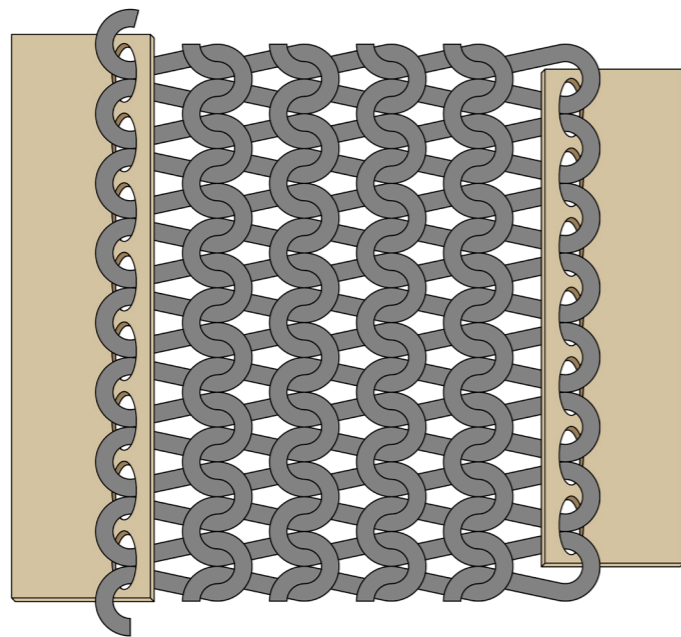

KNIT AND WOOD

Type of textile

Yarn

Type of wood

Lasercut plywood

Flexibility



Connection textile and wood

Connected in the edges

Weight



Knit with wood integrated to stabilize. The wood has holes that is knitted in to the fabric in the knitting process but the fabric could also be stitched in place afterwards.

This hybrid has a stability in the wooden direction but is soft and flexible in the other direction.

By shaping the wood and/or the position of the holes the fabric can be shaped in different ways. Depending on how much the knit is stretched out the textile in this hybrid has different expressions.

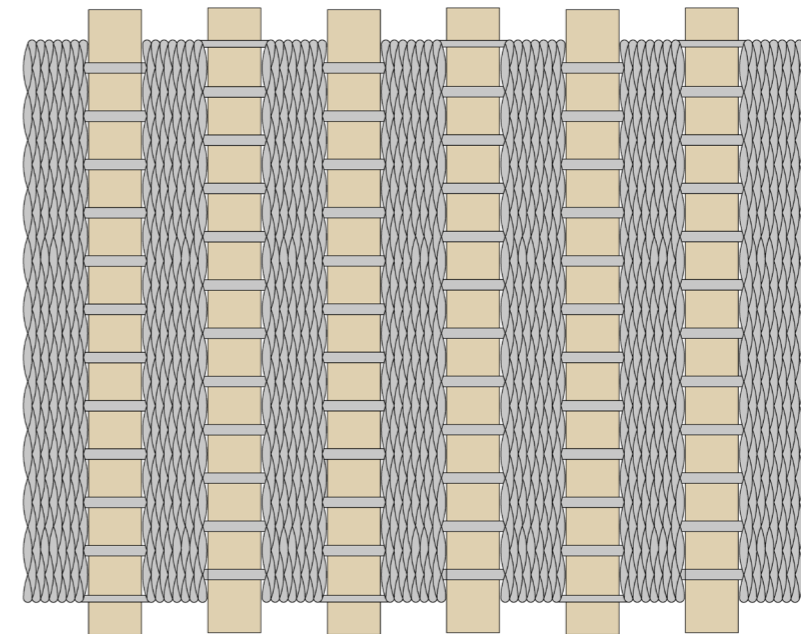

WOOD WEAVE

Wooden sticks weaved together with thread.

By alternating wooden planks with yarn in one direction woven together with yarn in the other creates a hybrid that is stiff in one direction but flexible in another.

The hybrid has a strong woven look. By varying the techniques in the yarn woven part it can have different transparency and expression.

Type of textile

Yarn

Type of wood

Sticks

Flexibility



Connection textile and wood

Both are integrated in technique

Weight



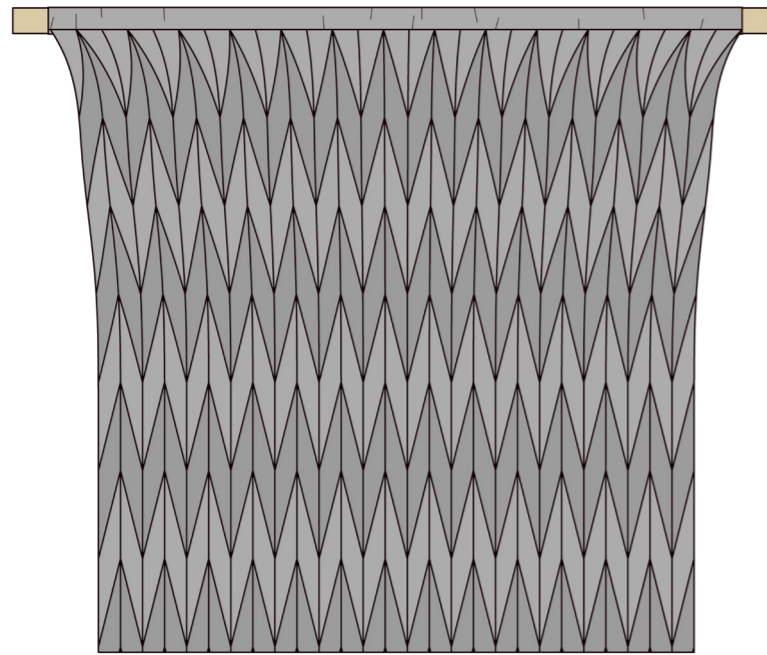

PLEATING WITH WOOD SEWN IN

Type of textile

Fabric

Type of wood

Planks

Flexibility



Connection textile and wood

The wood is sewn in.

Weight



Sewing in wooden planks to the edge of a herringbone pleated polyester fabric. Pleating is a technique that permanently folds fabrics.

These folds creates both a texture on the fabric and some sort of structural stability. When pulling out the fabric and letting go the folds will fall back in to the original place.

The shape of the wood in this hybrid can vary and by bending the planks other shapes can be formed.

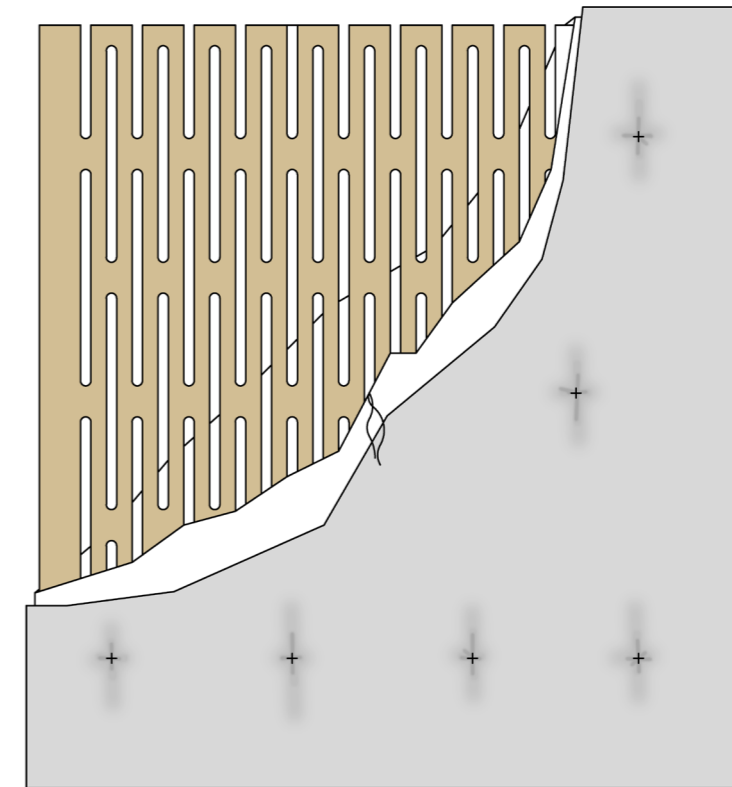

SOFTENED WOOD

Wood cut to be flexible with a cushioned fabric covered surface, with a layer of foam in between the wood and the fabric.

The wood is bendable but still stiff, with a little bit of force the wood will bend but go back to straight if let go.

The hybrid has a soft cushioned expression and is soft to the touch.

Type of textile

Fabric and stuffing

Type of wood

Lasercut plywood

Flexibility



Connection textile and wood

The wood is sewn in to the textiles

Weight



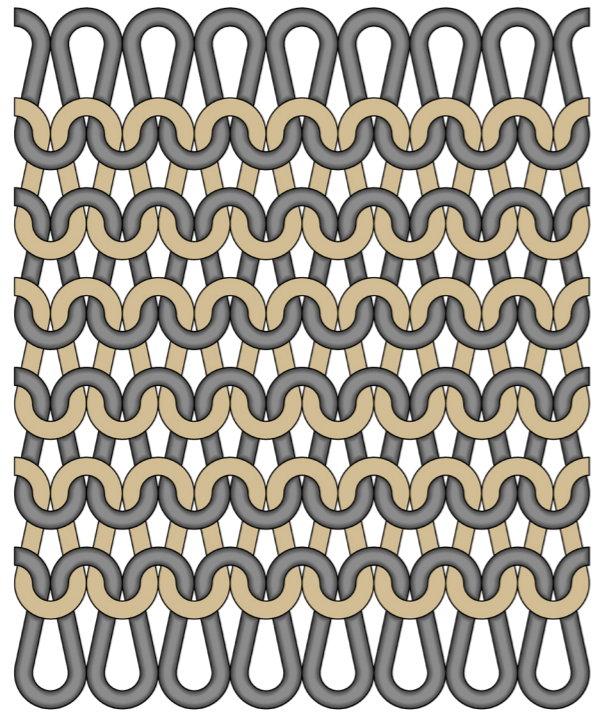

KNITTED WOOD

Type of textile

Thick yarn

Type of wood

Lasercut plywood

Flexibility



Connection textile and wood

Wood and yarn knitted together.

Weight



With laser cut wood mimicking knitted loops mixed with thread creates a flexible structure but with some structural stability. The wooden loops are stiff in contrast to the very soft thread.

The wood and thread is connected throughout the materials as they are mixed in every other row.

The hybrid has a strong knitted expression when also the wood takes on the expression of the textile.

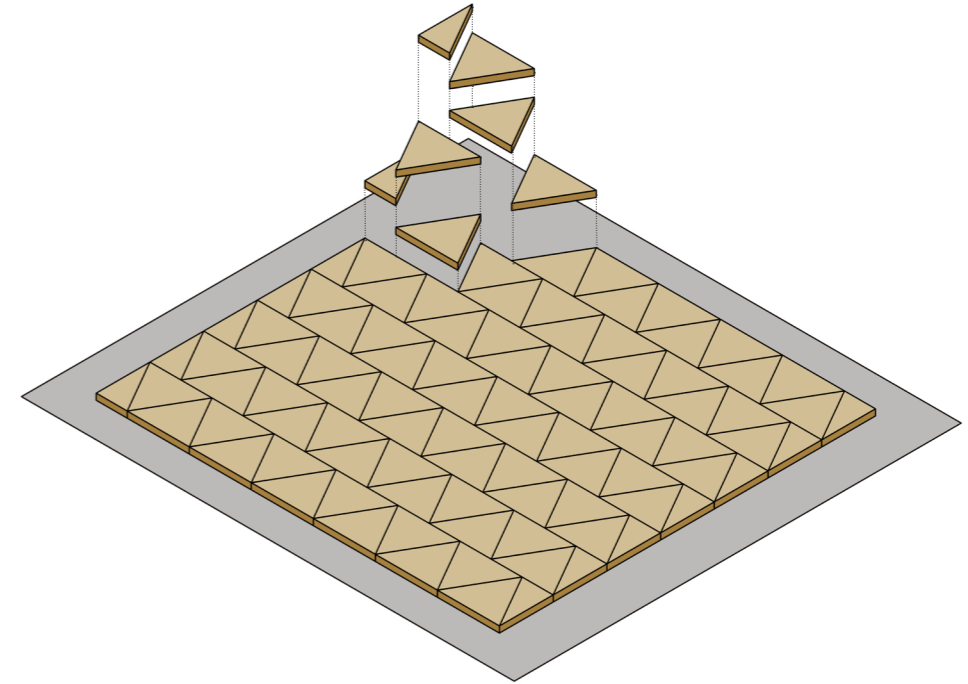

WOOD ON FABRIC

By glueing fabric on a grid of wooden shapes the structure gets bendable in one direction but stiff in the other due to the thickness of the wood.

By changing the spacing in between the CNC milled pieces or the angle on the edge of the wood the wooden side get more flexible.

Using triangles is a way to create complex forms on the hybrid but other shapes of wood is also possible.

Type of textile

Woven fabric

Type of wood

CNC milled plywood

Flexibility



Connection textile and wood

Glued on top of eachother

Weight





ARCHITECTURAL IMPLEMENTATION

FAÇADES & SPACE DIVIDERS

Showcasing the hybrids as architectural elements to explore the materiality, scale and functions of the hybrid systems.

FAÇADES

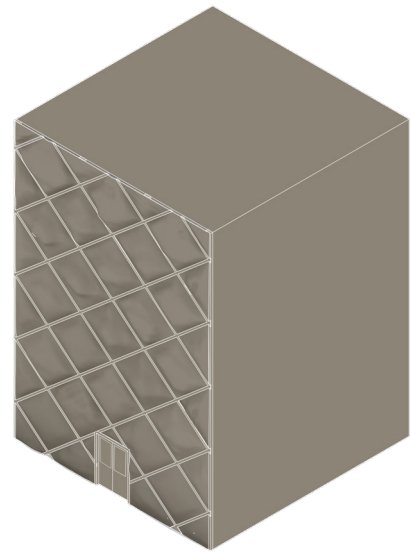

Excessive knit

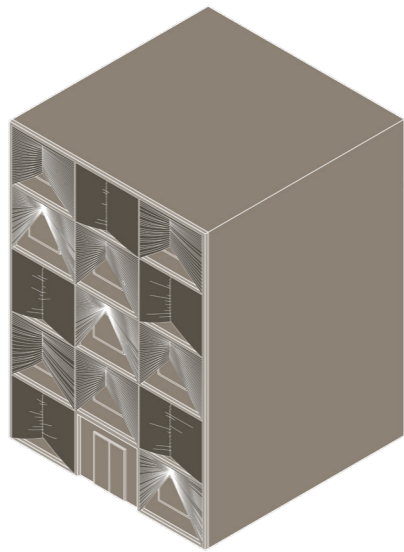

Ruched on wood

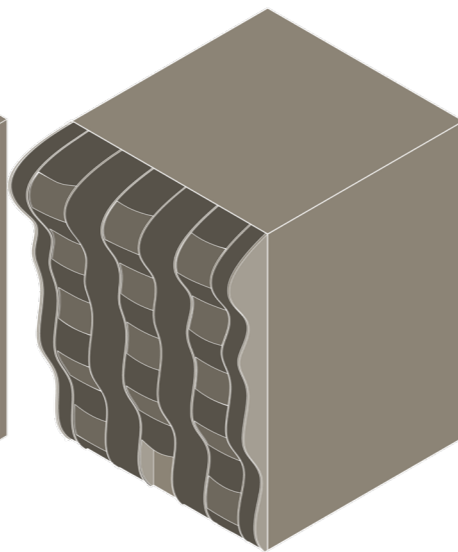

Knit and wood

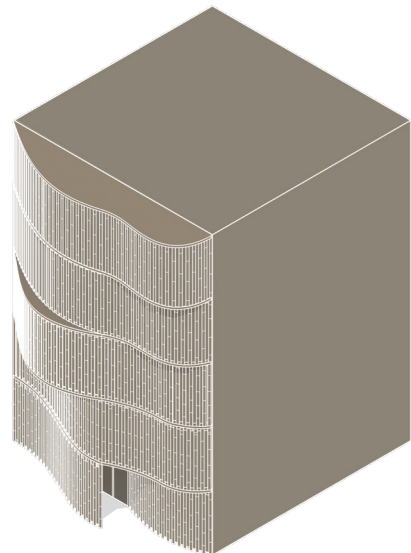

Wood weave

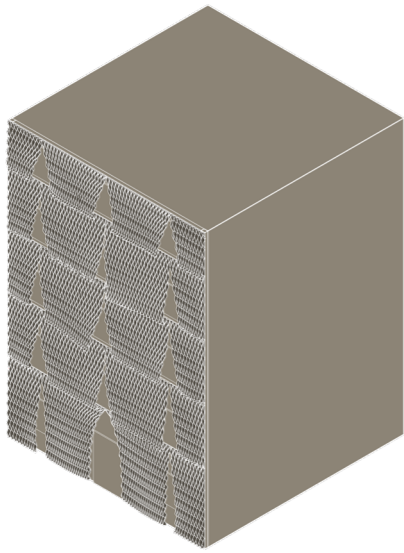

Pleating with wood sewn in

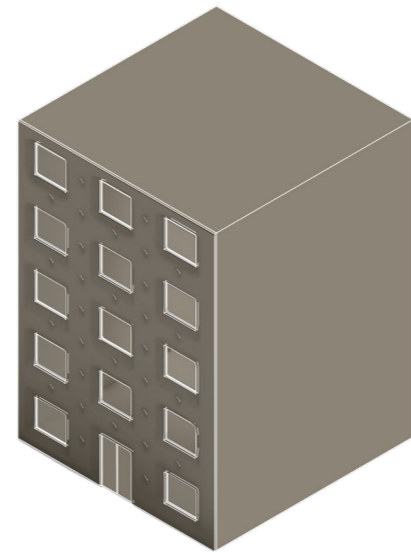

Softened wood

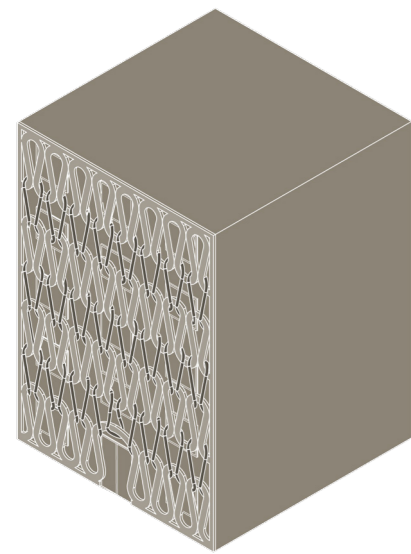

Knitted wood

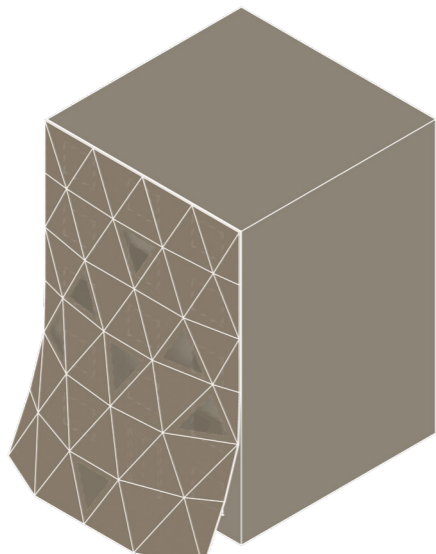

Wood on fabric

In architectural theory about textiles architecture one of the most prominent theorists is nineteenth century theorist Gottfried Semper who describes that textiles has the essence of walls and division of space. He writes about hanging carpets and woven wicker as the original enclosures (Semper, 2010). To reference back to that I decided to do more vertical elements, the façade a large outdoor wall hanging and the space divider.

The systems are first shown as a second skin façade material. They are like the woven wall hangings described by Semper but as textiles today can endure weathering they are showcased outdoors. The façade is added on to a generic five story building with some complexities, such as openings, windows and a door on the first floor.

With the façade I want to exhibit the aesthetic and functional qualities of the hybrids. The material properties, expressions and transformability have been the main focus to show in the façades. The systems also needs to react the openings of the façade with transparency in the materials or openings made in the hybrid.

On the following pages the façade proposals of the eight hybrid systems are exhibited and described.

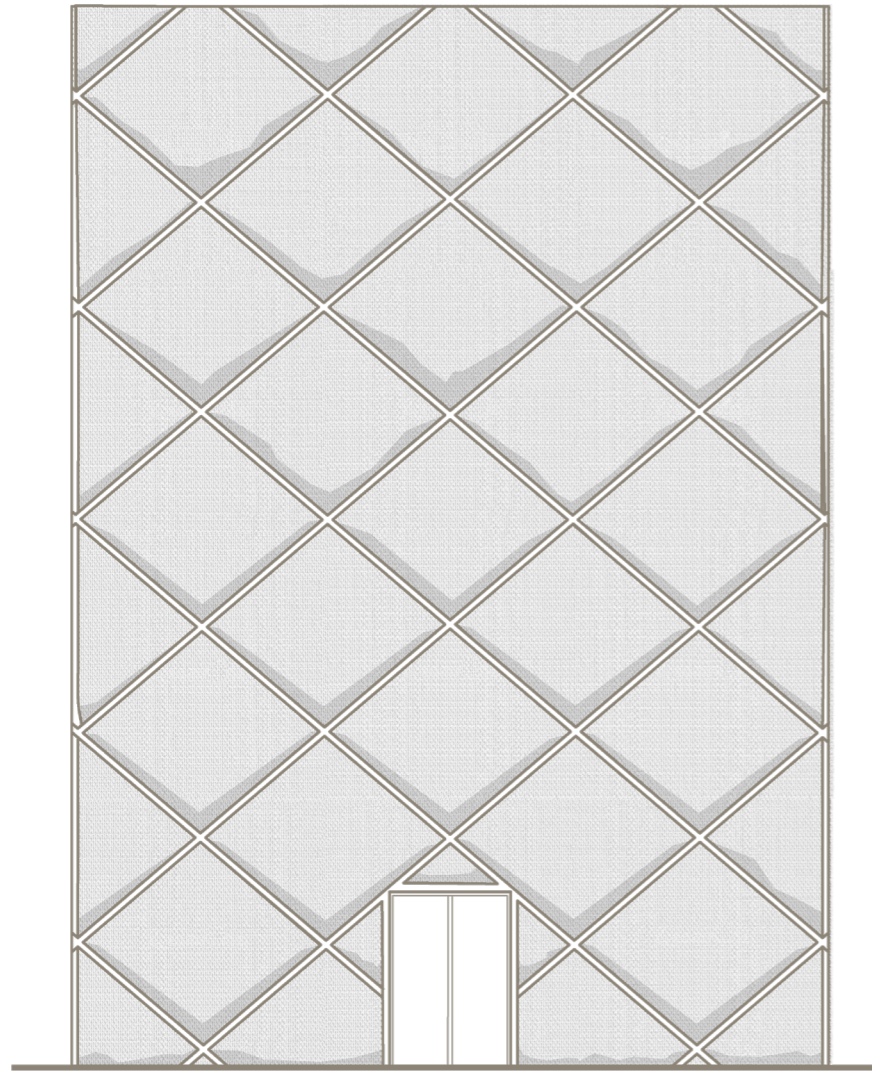

Elevation 1:100

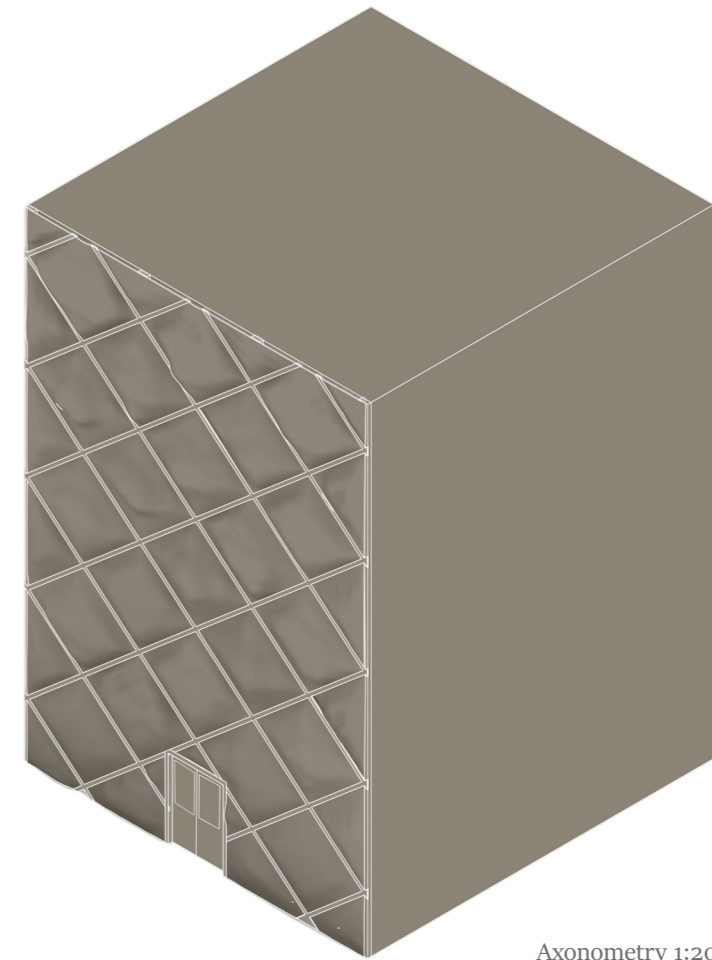

Axonometry 1:200

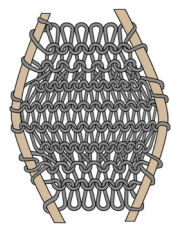

EXCESSIVE KNIT

The façade of *Excessive knit* is constructed by a wooden frame with planks going octagonally in two direction over the façade. The space between the wood is knitted with an excessive amount of yarn to create a bubbly and textured look. The wood is integrated to the edge of the knit.

With a loose knit the textile is fairly transparent to let in light through the windows on the façade.

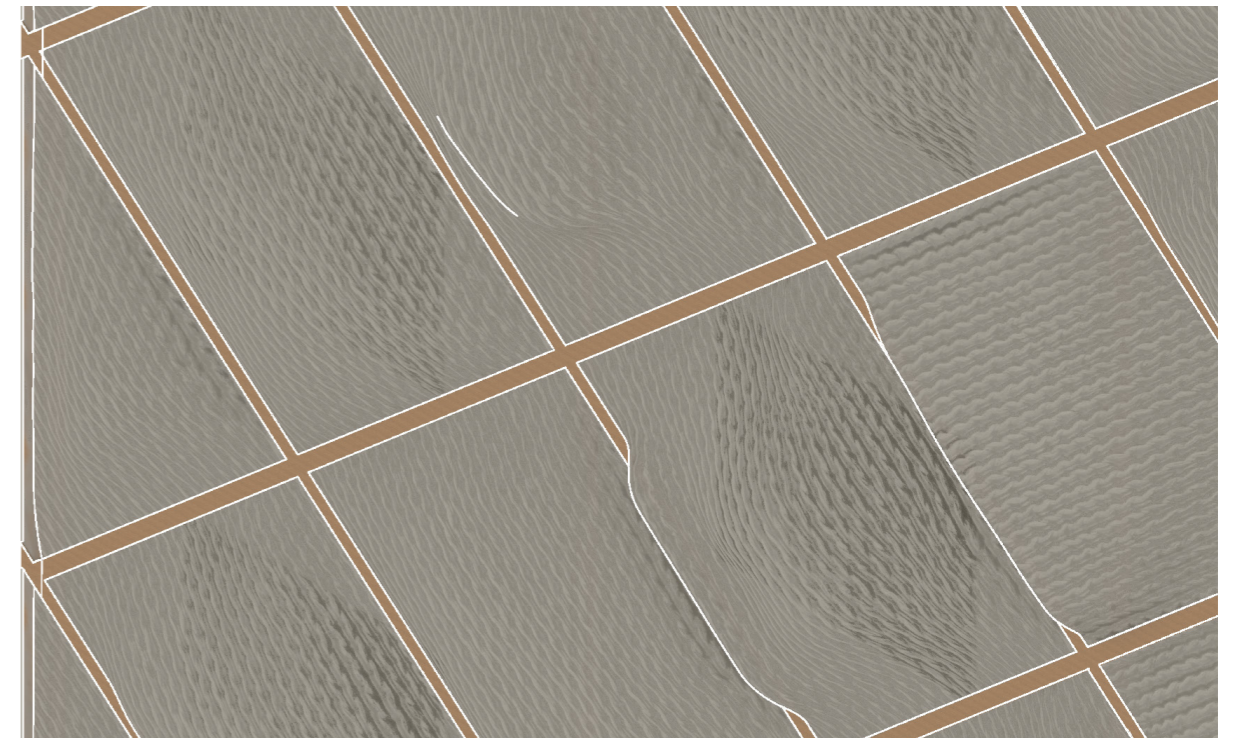

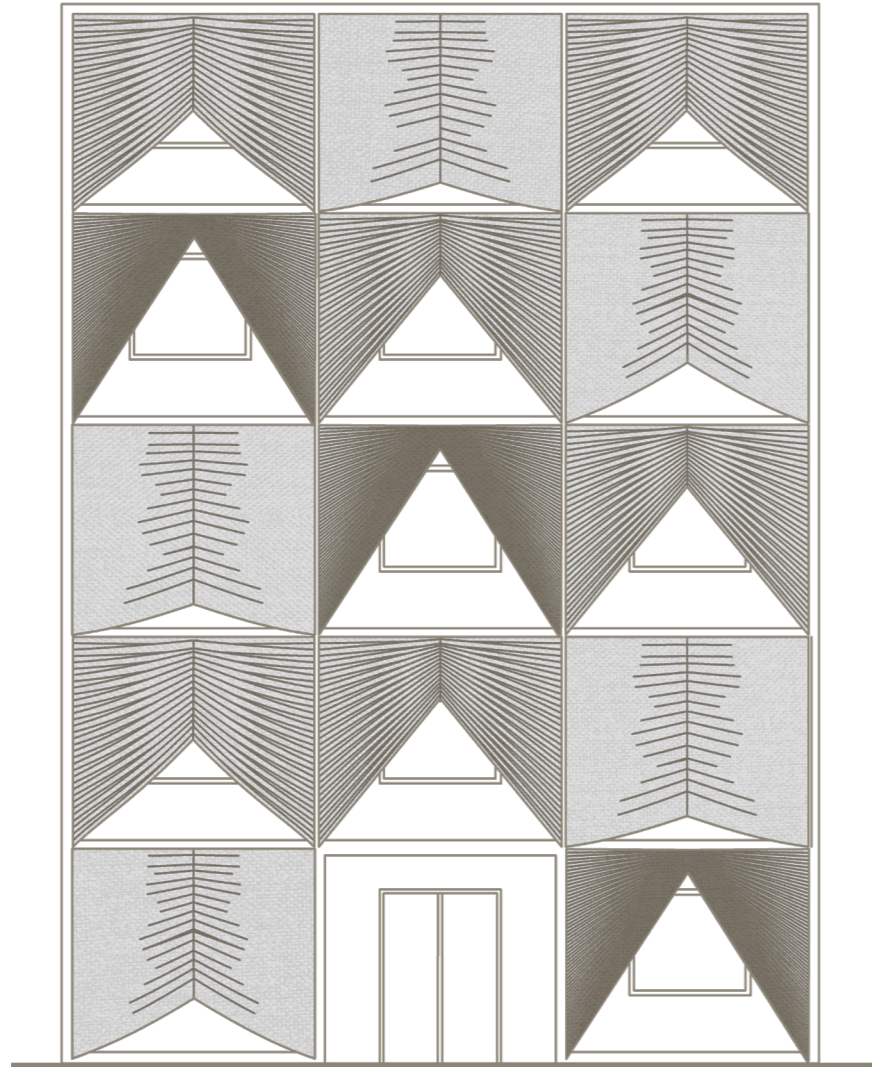

Elevation 1:100

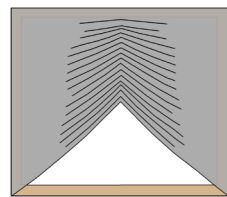

RUCHED ON WOOD

Ruched on wood façade consists of a structure of wood that creates a large square around the windows and a gap for the door. The fabric is attached to three sides of a wooden frame that is mounted on the larger structure.

By ruching together the textiles from the windows by a string the façade can be more opened or closed. This creates different expressions of the façade by both opening up and creating volume in the fabric.

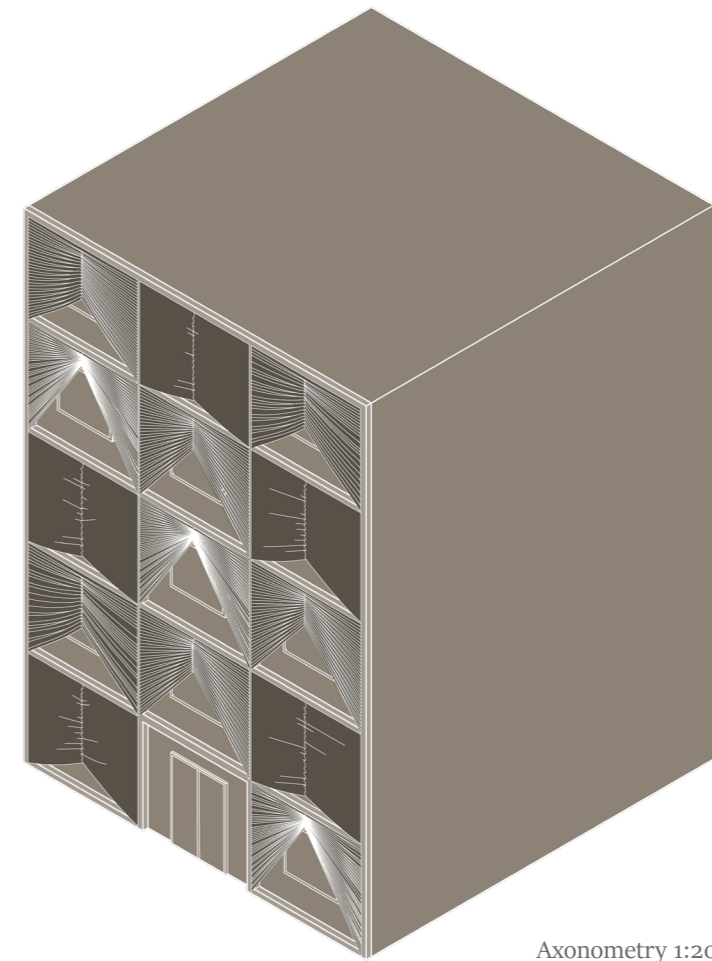

Axonometry 1:200

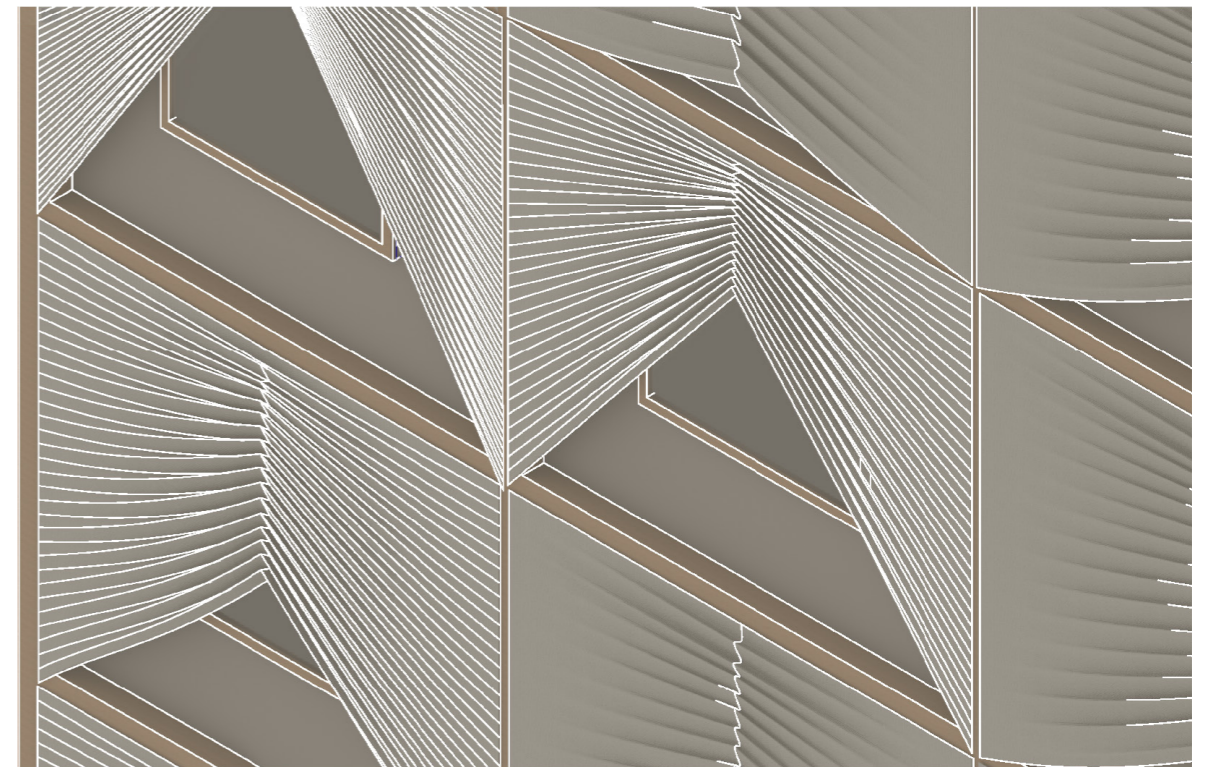

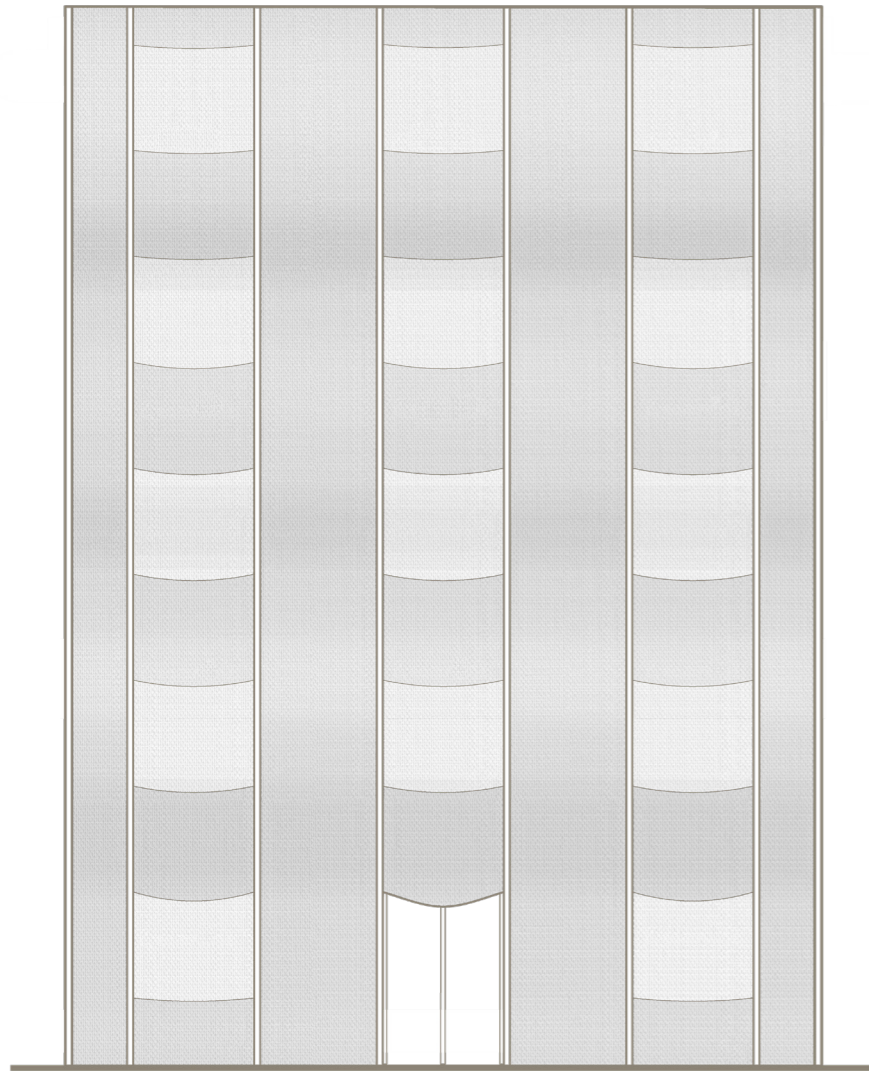

Elevation 1:100

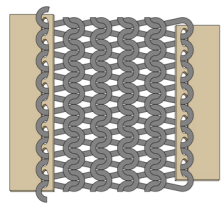

KNIT AND WOOD

A three dimensional façade system of knitting in between formed CLT panels. The knit is attached to the wood by holes on the edge where the loops go through.

By using differently thick yarn or knitting needles the transparency can be alternated in the fabric. Here, the fabric in front of the windows is looser and more transparent to let more light in and improve the possibility to see through.

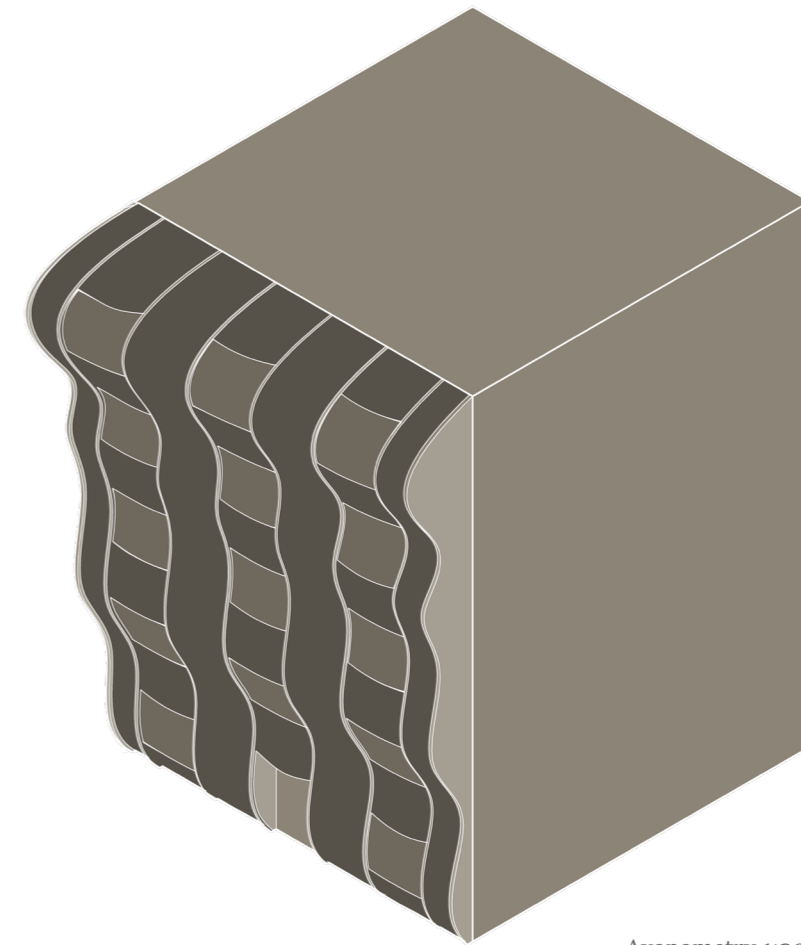

Axonometry 1:200



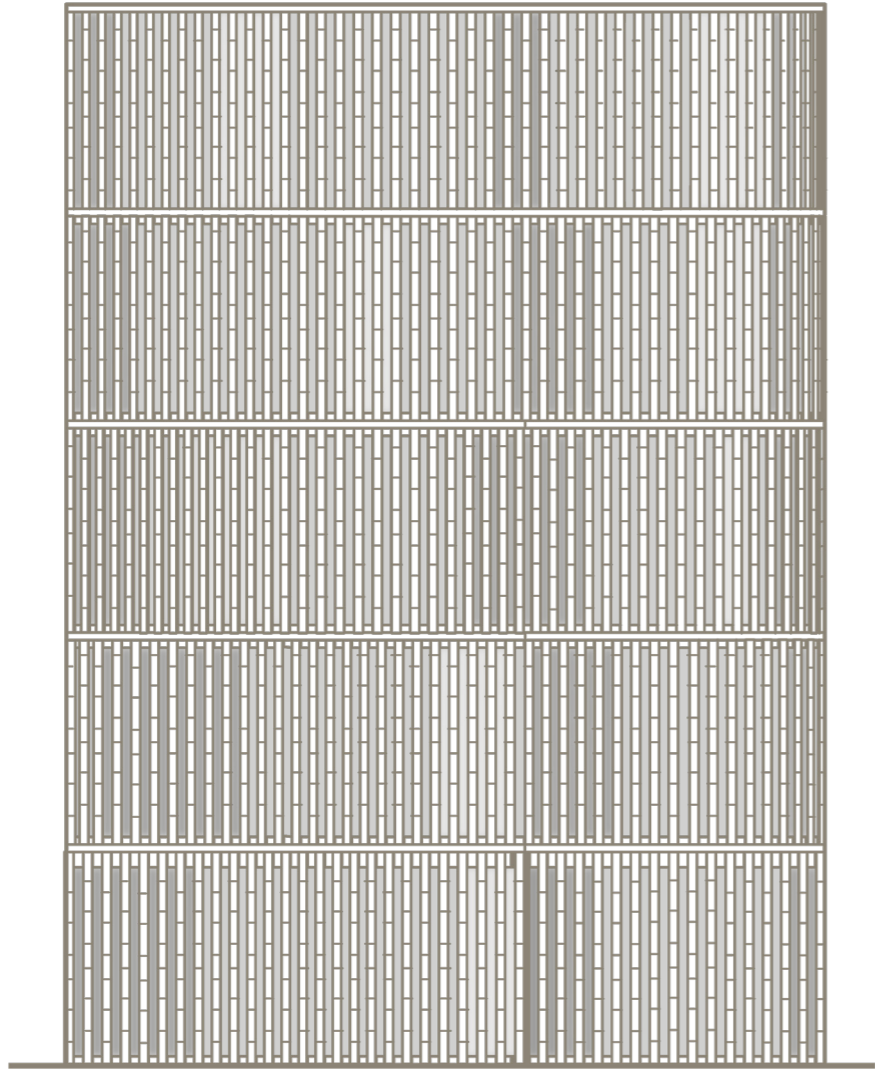

Elevation 1:100

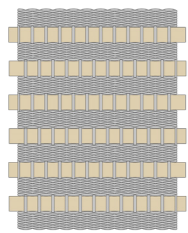

WOOD WEAVE

The façade application of *Wood weave* is showing the hybrid covering the façade attached to a floor that creates balconies on each floor.

The textile is woven rope that hold the wood in place. By leaving gaps in the rope weave, openings and lookouts are created.

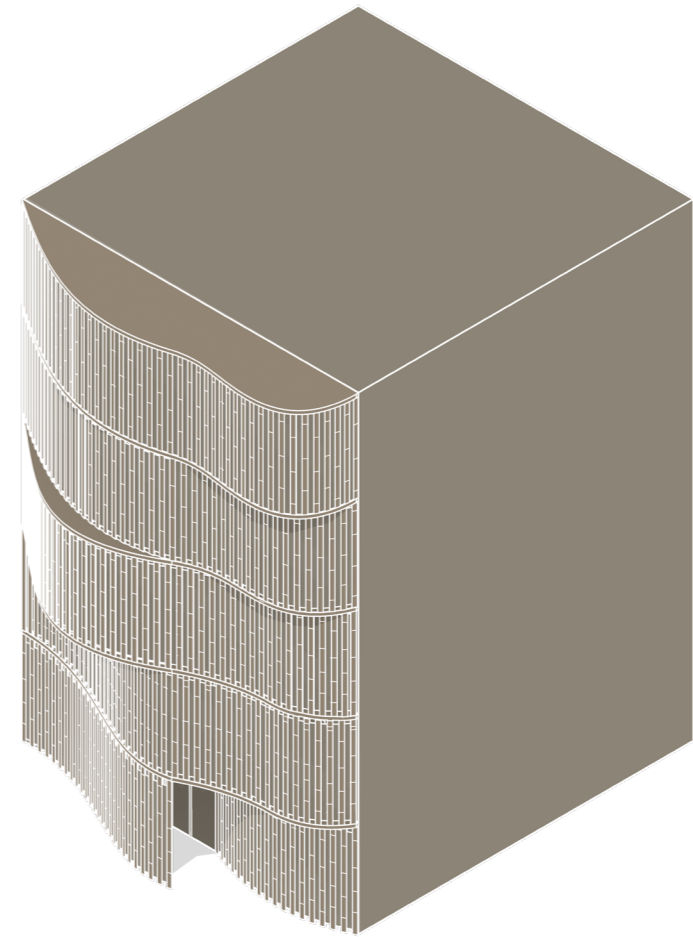

Axonometry 1:200

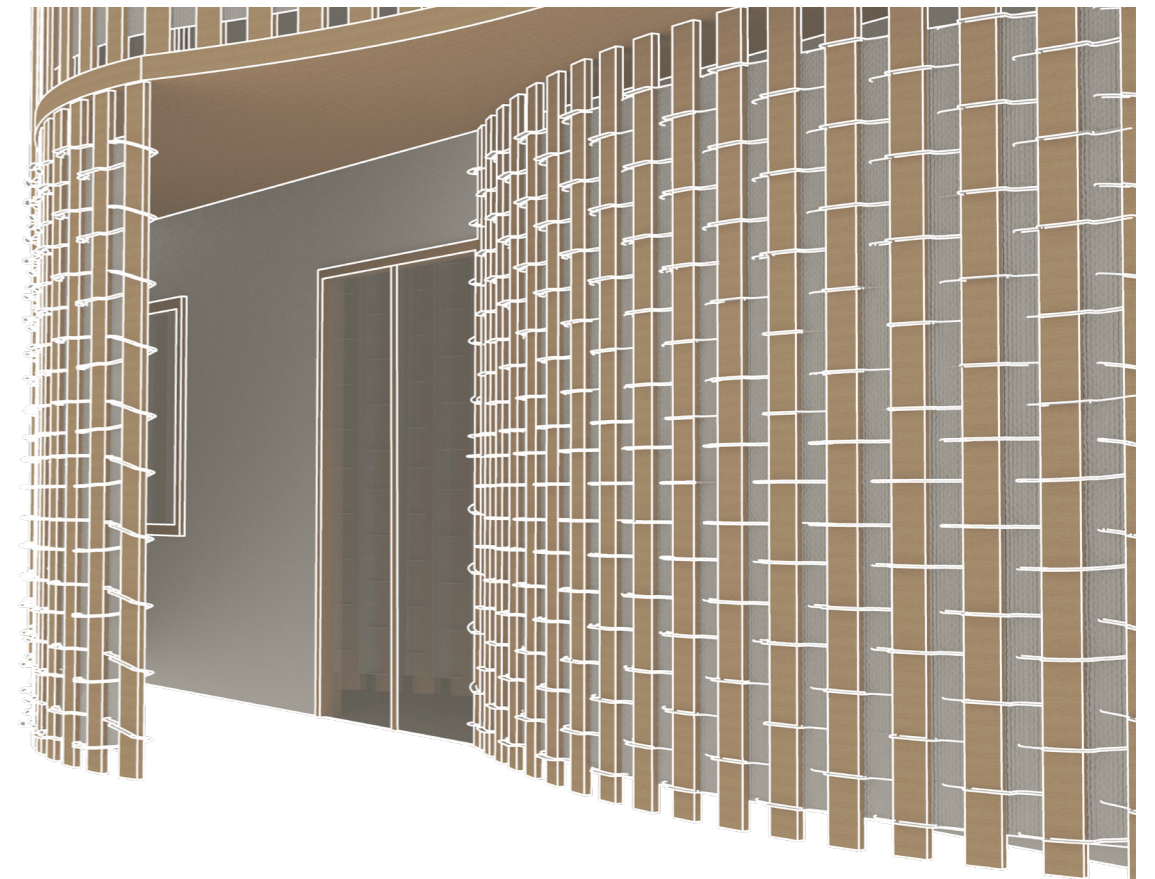

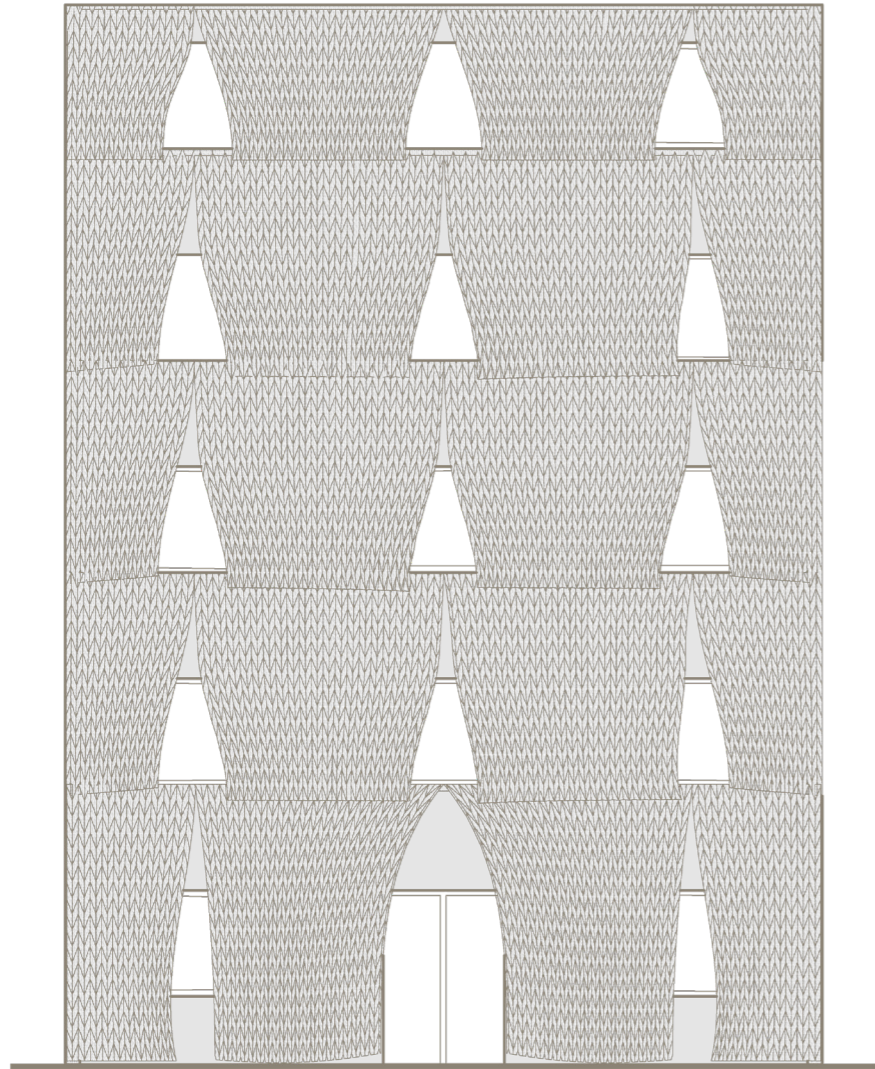

Elevation 1:100

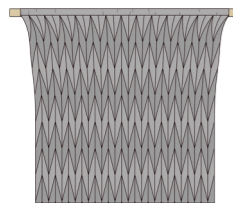

PLEATED WITH WOOD SEWN IN

The pleated fabric works as an exterior curtain giving dimension and texture to the building. The fabric is sewn on vertical wooden glulelam beams spanning the width of the façade.

The fabric is split by the windows and the force of the pleat pulls the fabric together which creates openings.

Using a polyester fabric the pleats would hold up for a long time.

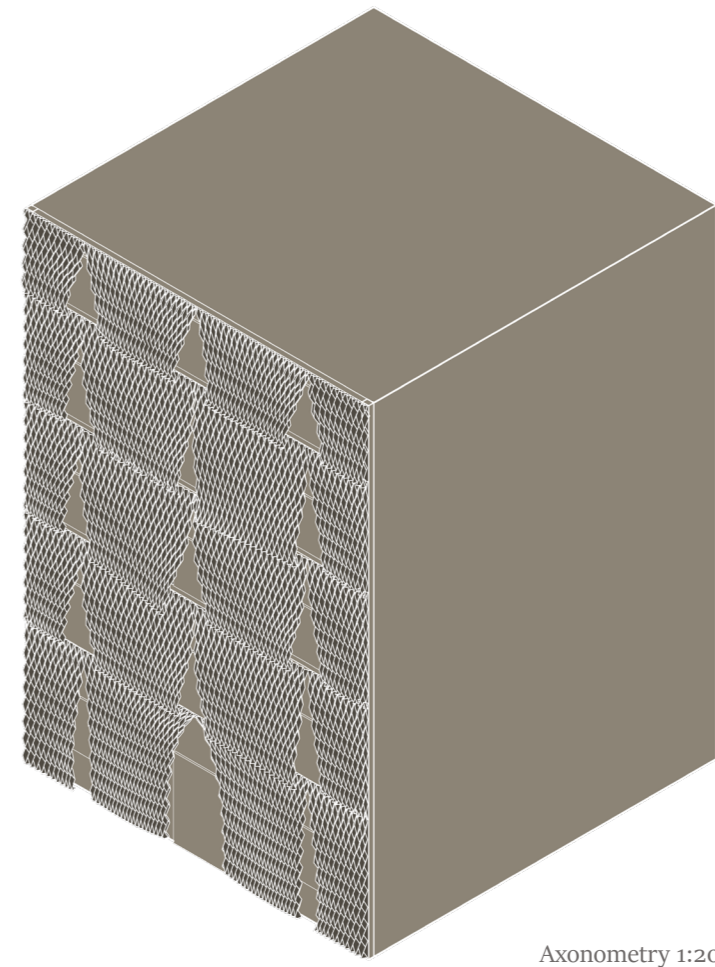

Axonometry 1:200

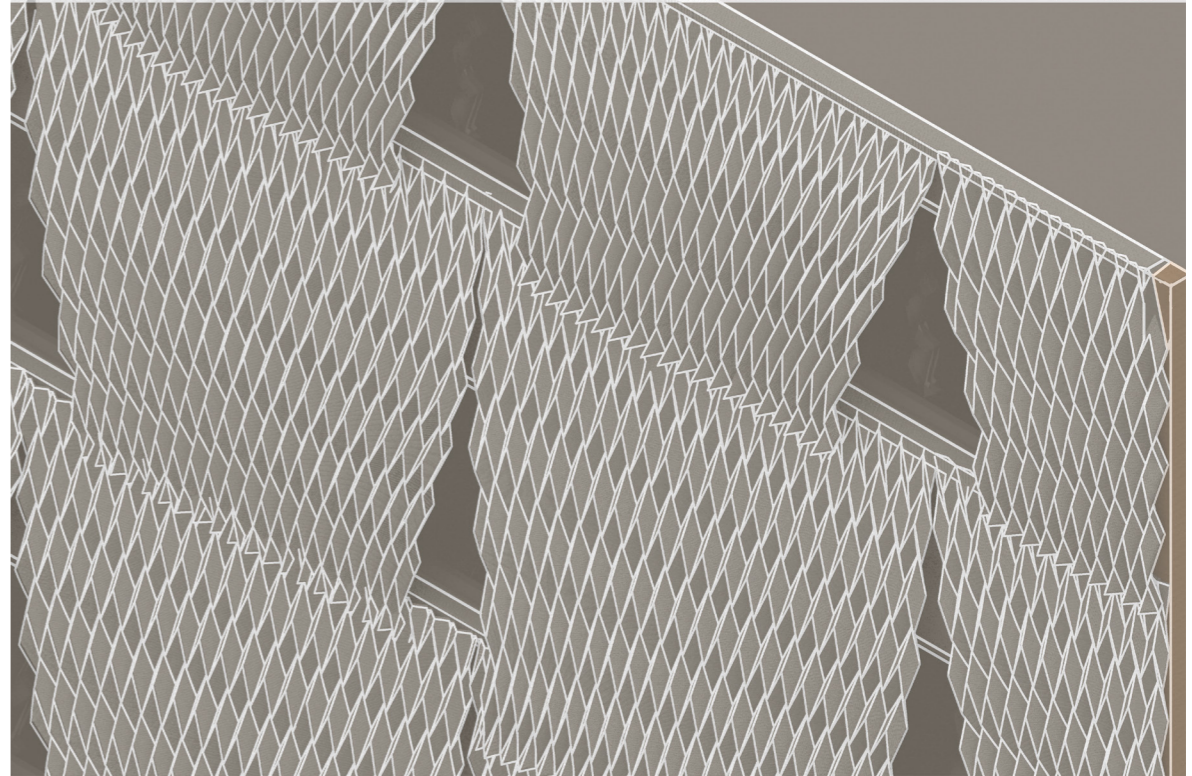

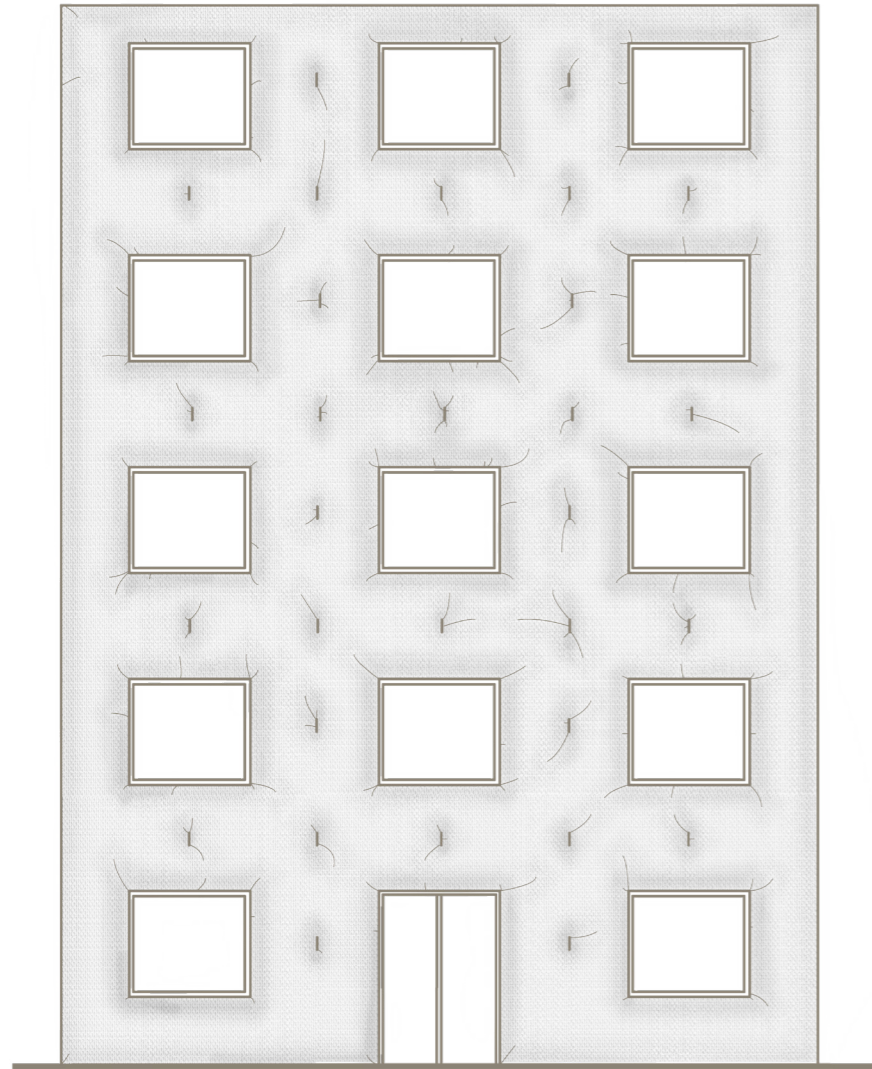

Elevation 1:100

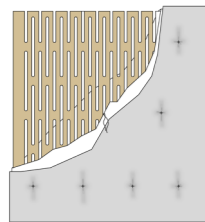

SOFTENED WOOD

The façade made up of the hybrid *Softened wood* mainly shows the cushioned effect of the hybrid.

The hybrid has an outer layer of woven fabric which is sewn on to a wooden structure with a layer of cushioned material in between.

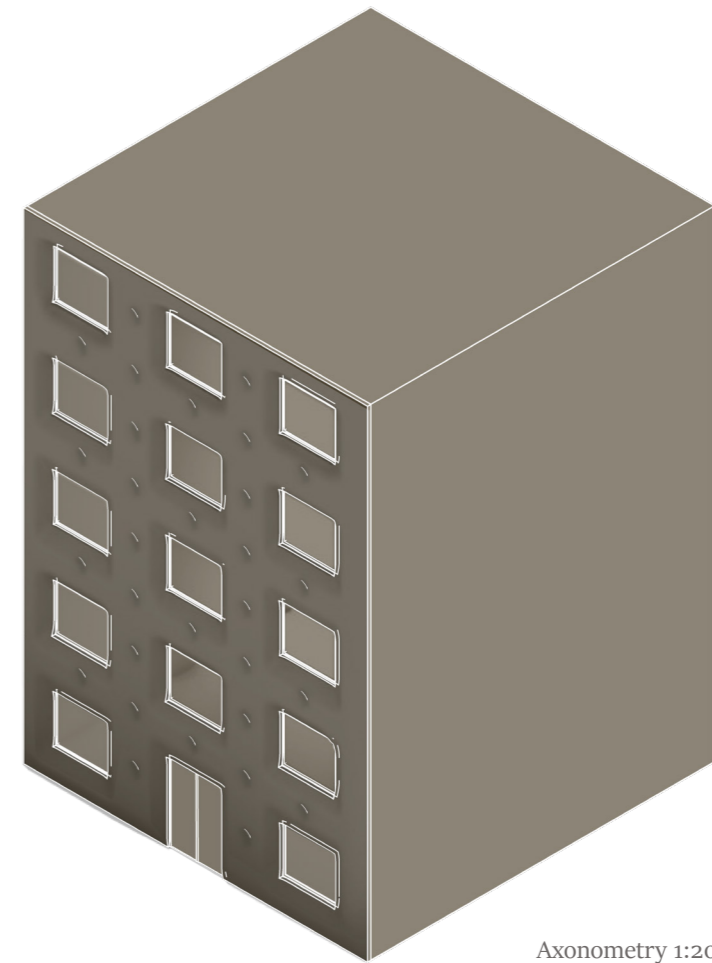

Axonometry 1:200

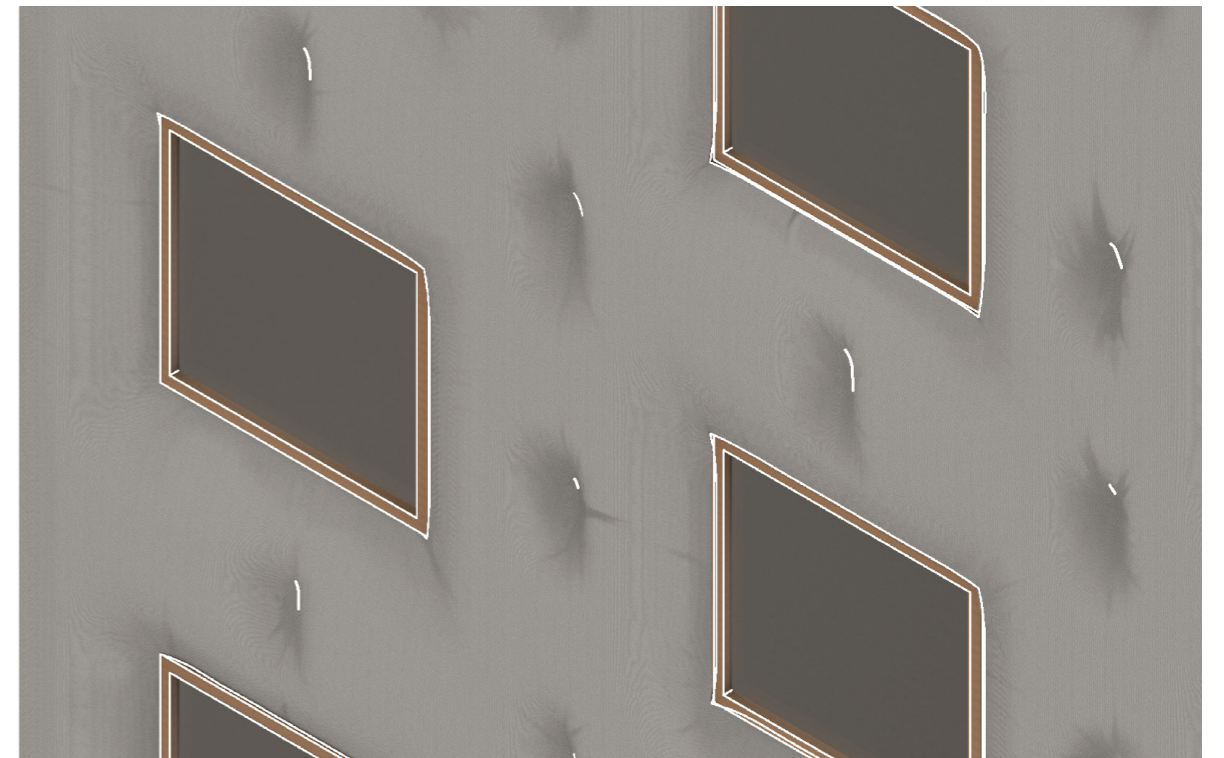

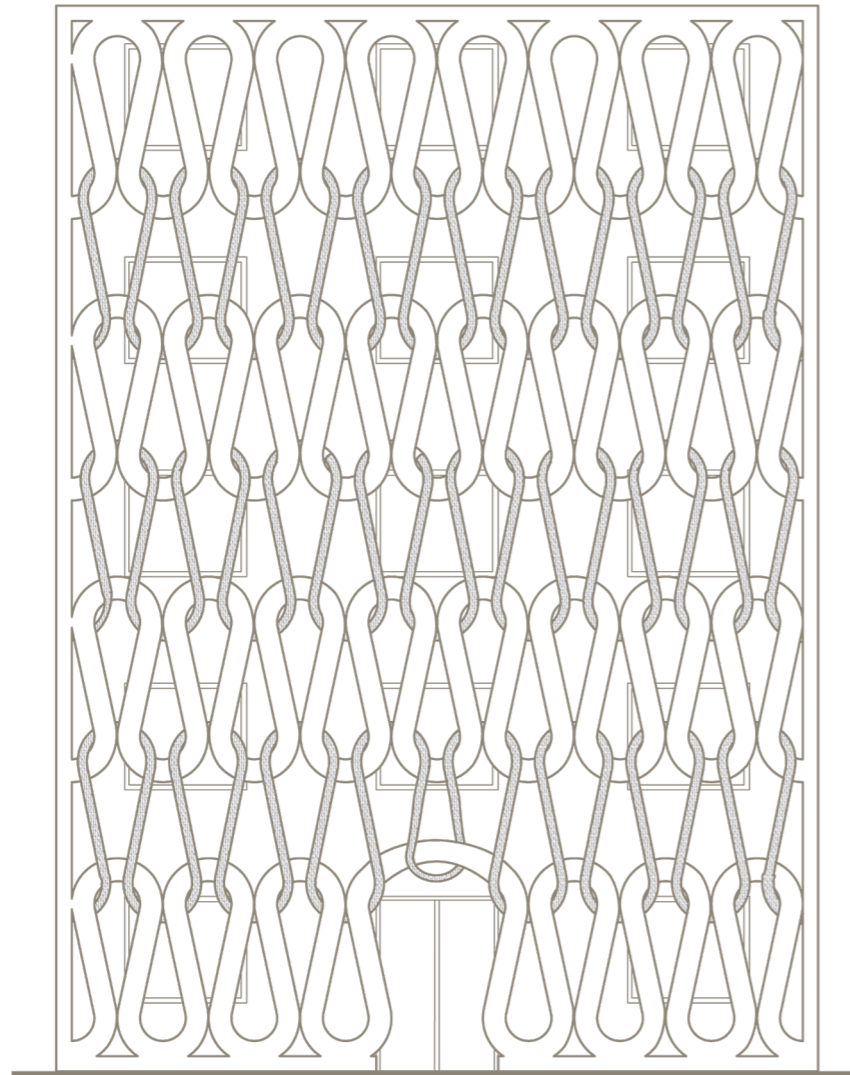

Elevation 1:100

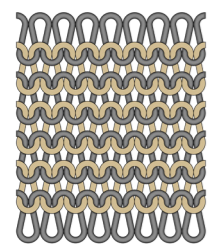

KNITTED WOOD

A façade made up of big CLT elements cut to mimic a row of loops in a knit, knitted together using a stuffed fabric tube. This hybrid has a strong textile expression and shows both wood and textile qualities.

The fabric tube is similar to the one found in the exhibition *Weird sensation feels good* (see page 23). But is made of a waterproof sturdier material.

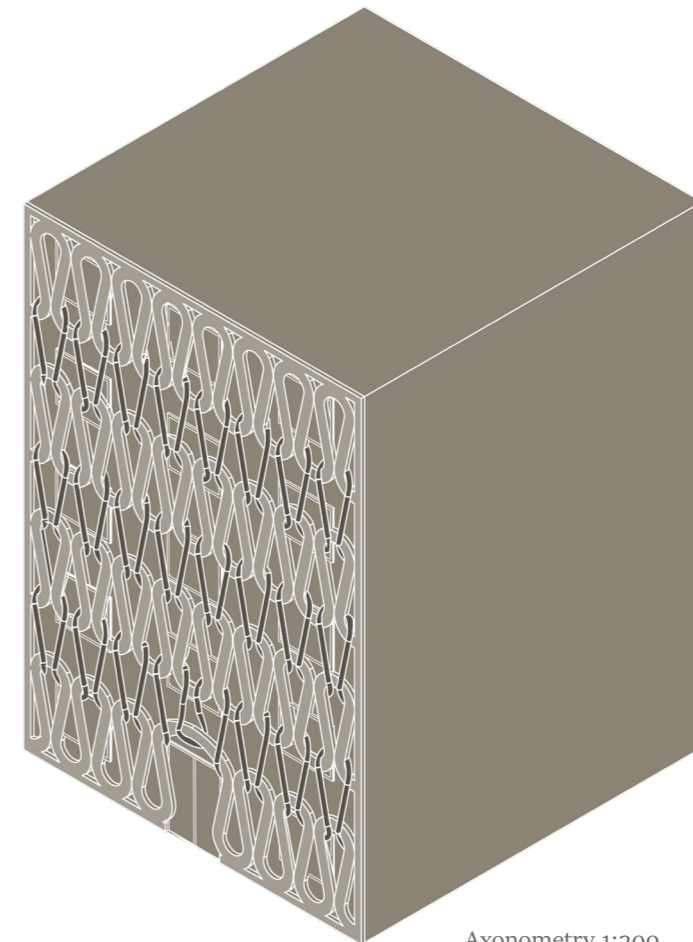

Axonometry 1:200

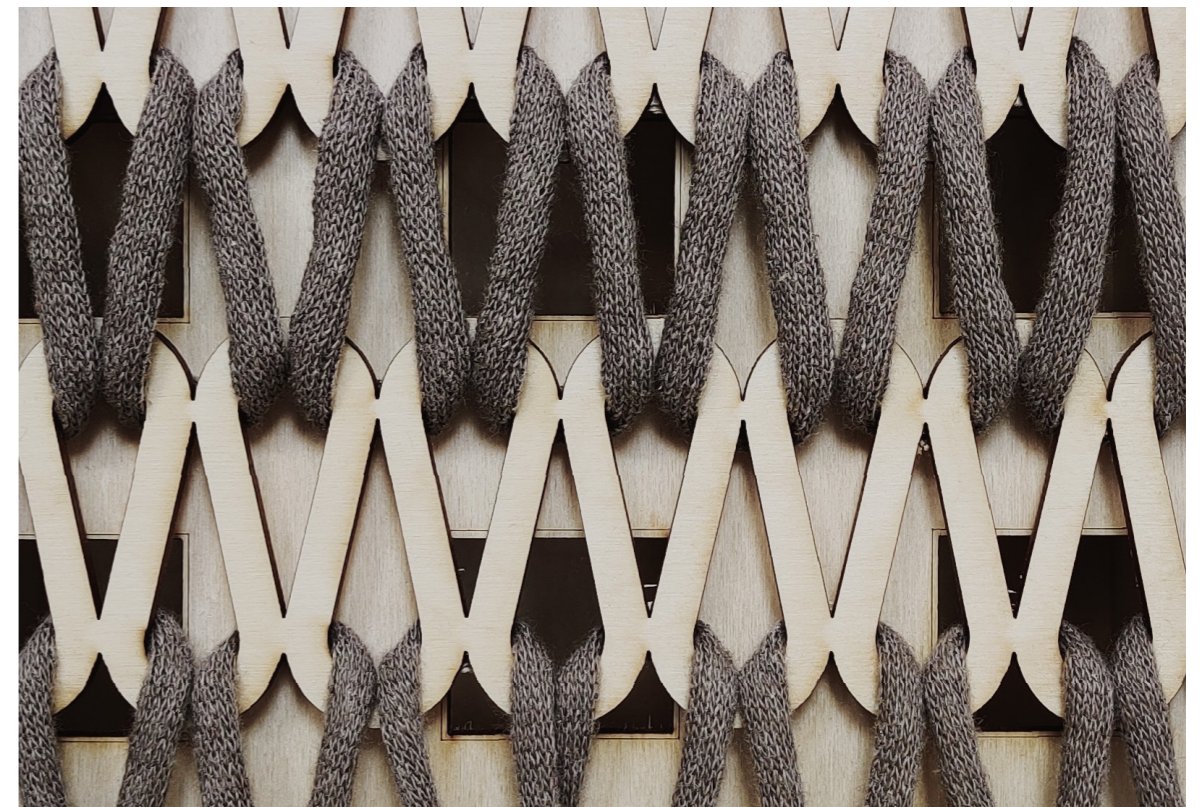

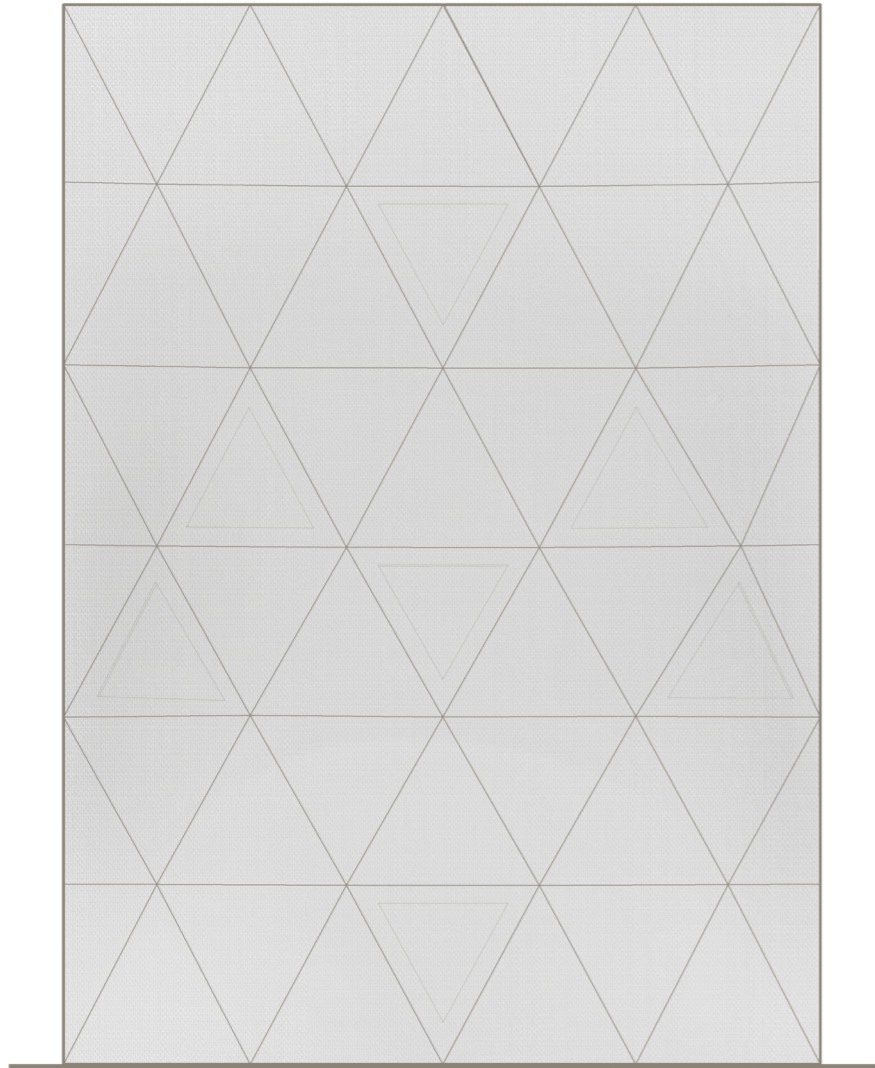

Elevation 1:100

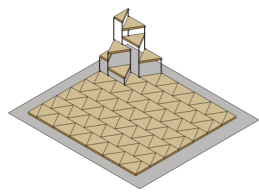

WOOD ON FABRIC

The façade using the hybrid *Wood on fabric* is made up of CLT panels and a strong fabric. The panels are cut in triangular shapes with angled edges cut to create a self supporting structure that holds together by the fabric.

The wood on fabric structure creates a room between the inner façade and the outer. Some of the panels are cut out in the middle to let some light through.

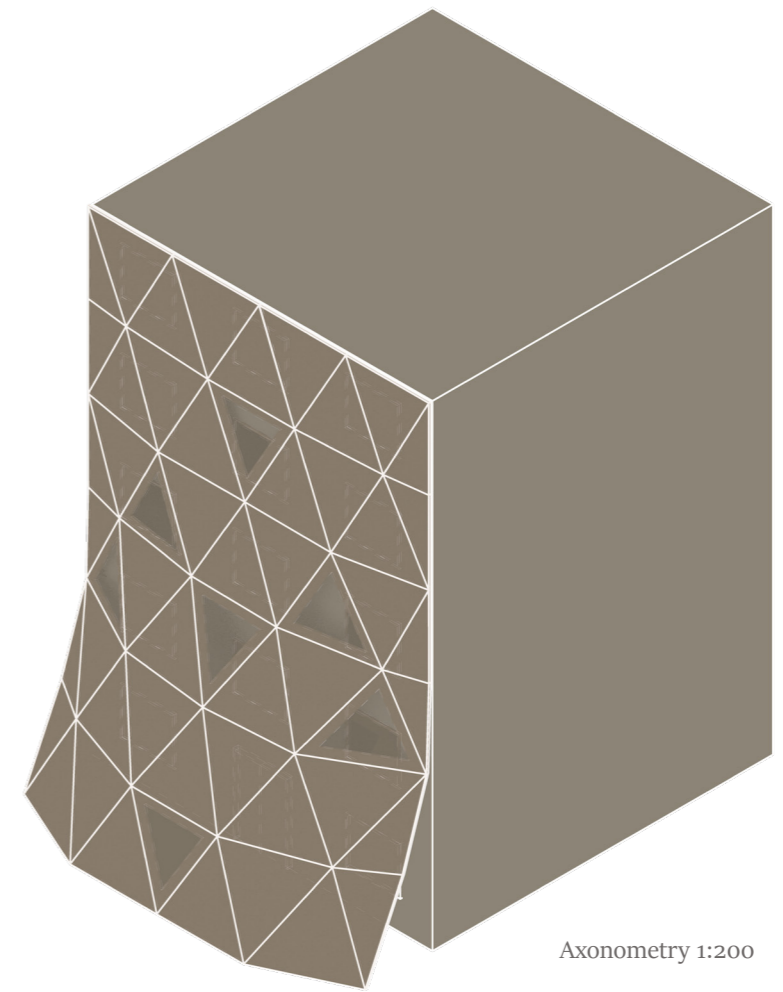

Axonometry 1:200

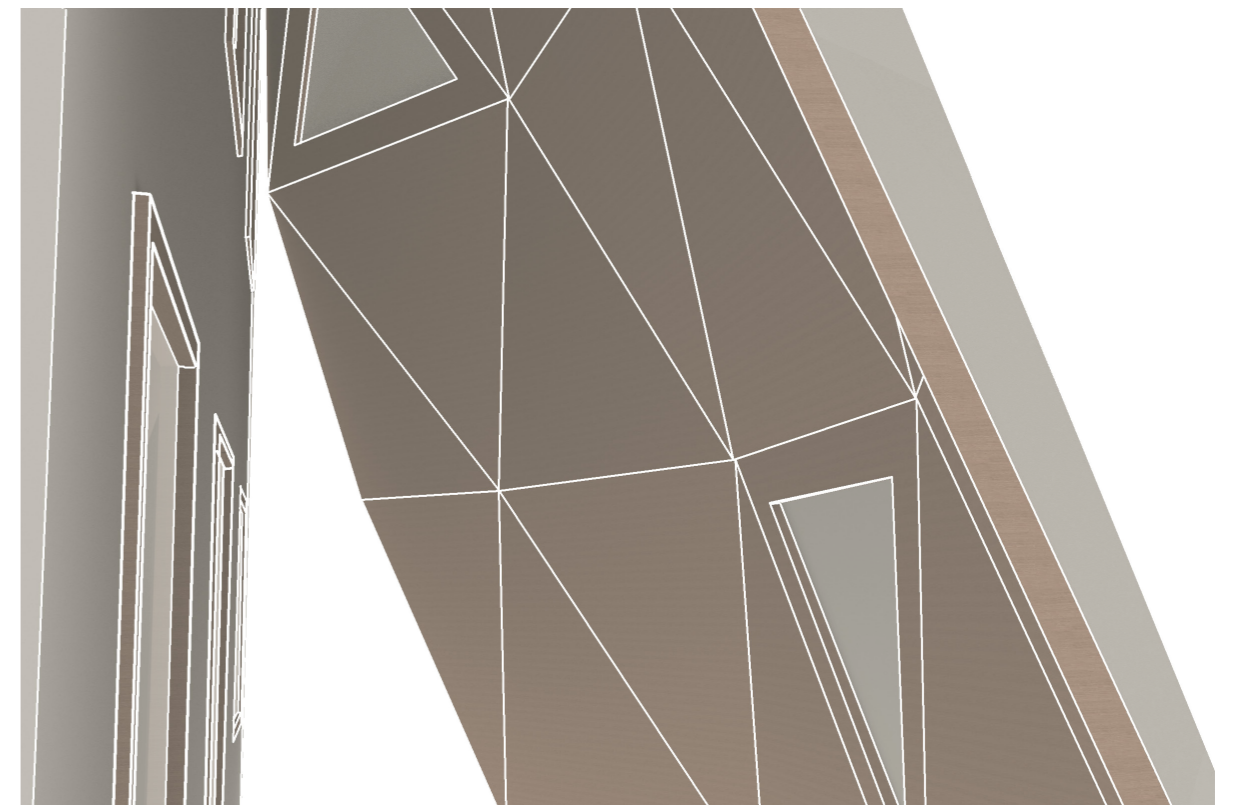

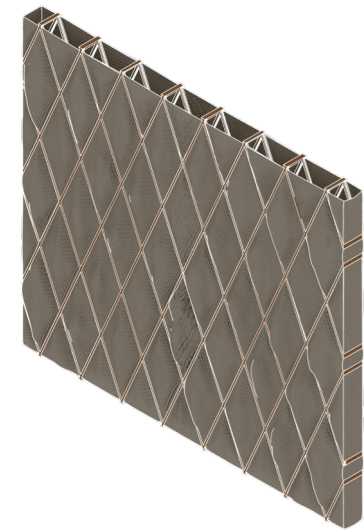

Excessive knit

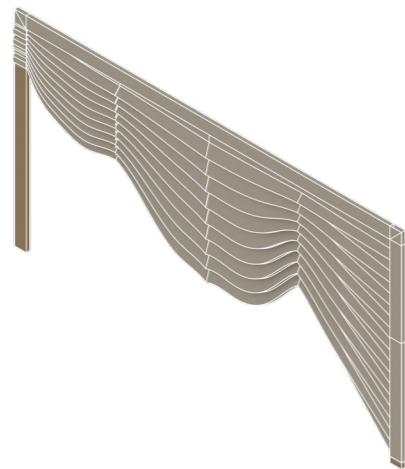

Ruched on wood

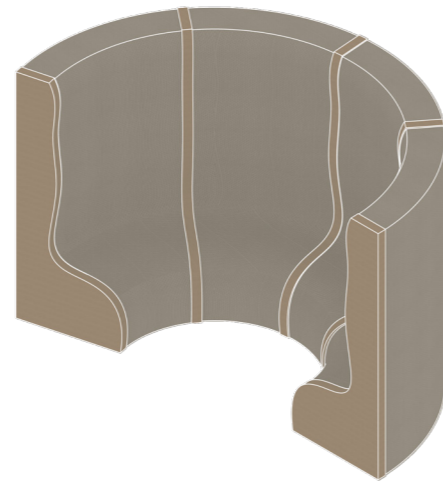

Knit and wood

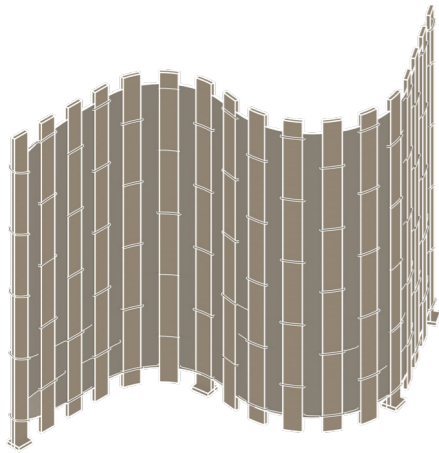

Wood weave

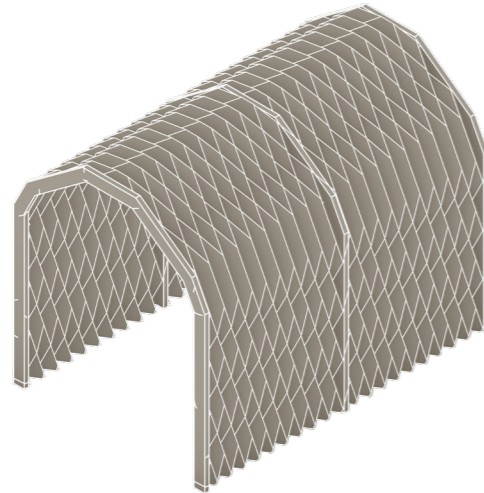

Pleating with wood sewn in



Softened wood

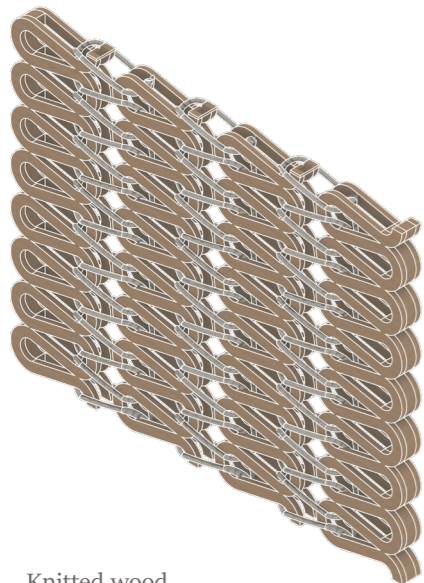

Knitted wood

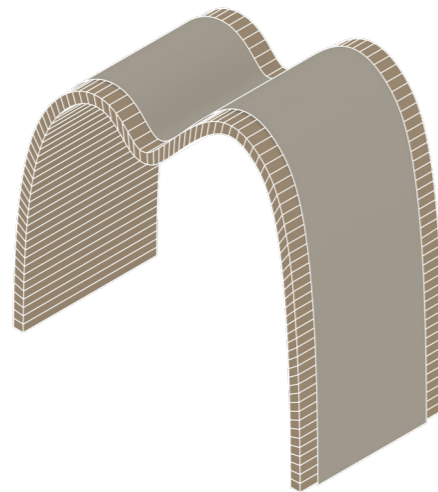

Wood on fabric

SPACE DIVIDERS

To showcase other qualities than the large scale façades, the hybrids are used to create smaller self supporting structures that can be used to divide spaces. The uses for these are wide and can range from enhancing areas in a large setting, to give division in a office landscape, or to create privacy for the bed in a studio apartment.

With a focus on exhibiting flexibility, structural stability and a use for the hybrid in a smaller scale the space dividers are created. They vary from vertical, flexible wall elements to expandable and collapsible arches.

The space dividers are produced to highlight other expressions and qualities of the hybrids than the façades are focusing on. The hybrid systems take on other forms and shapes to showcase the diversity of the material combinations.

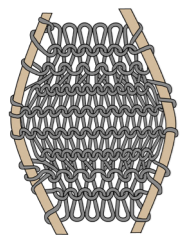
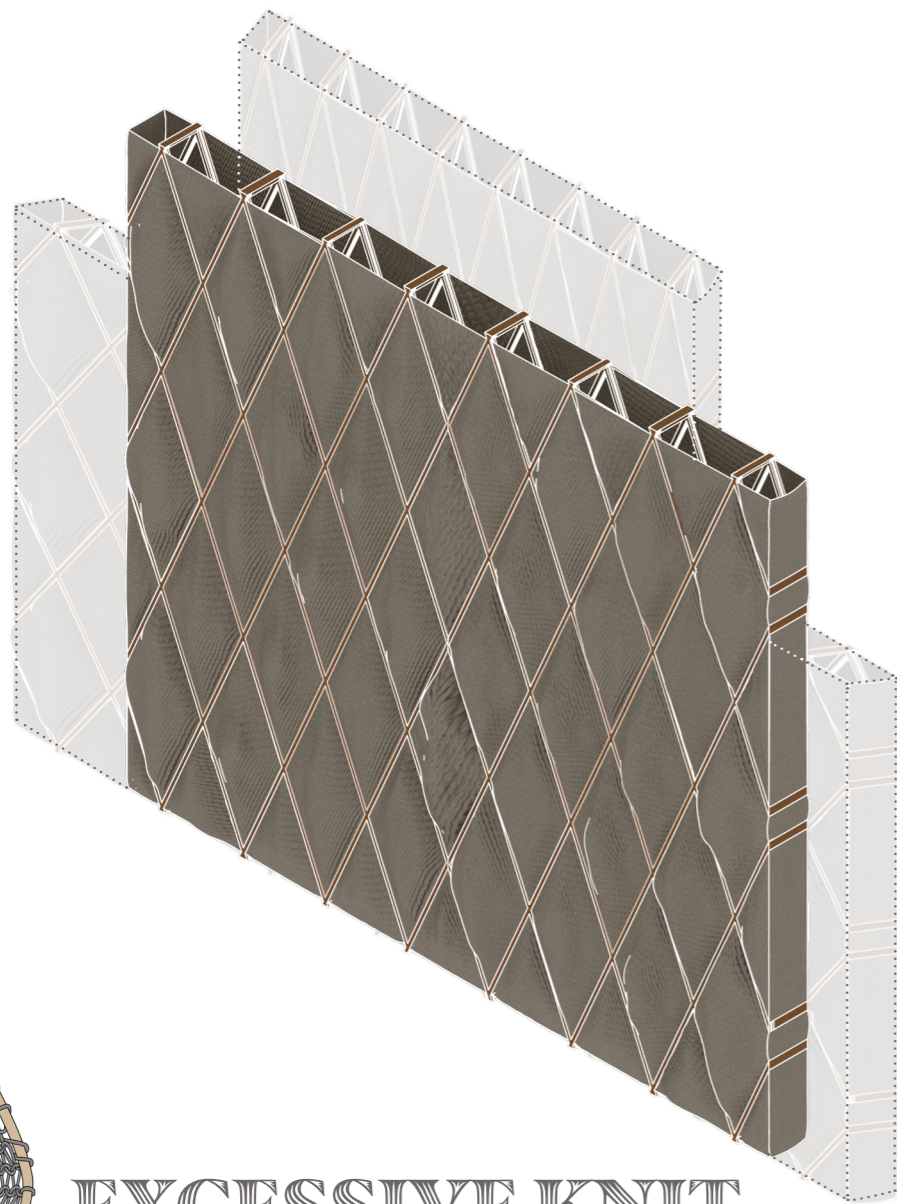

EXCESSIVE KNIT



Excessive knit shown as a semi flexible parting wall. The wall is two sided and is connected on the sides with a spacing in between.

The wood is in a adjustable diamond pattern that is knitted together with an excessive knit. If one pushes the wall together it gets a bit higher and the other way around. So the wall can change size but not form.

The knit creates a soft and bulky expression. The thickness and creases of the knit could have sound absorbing ability.

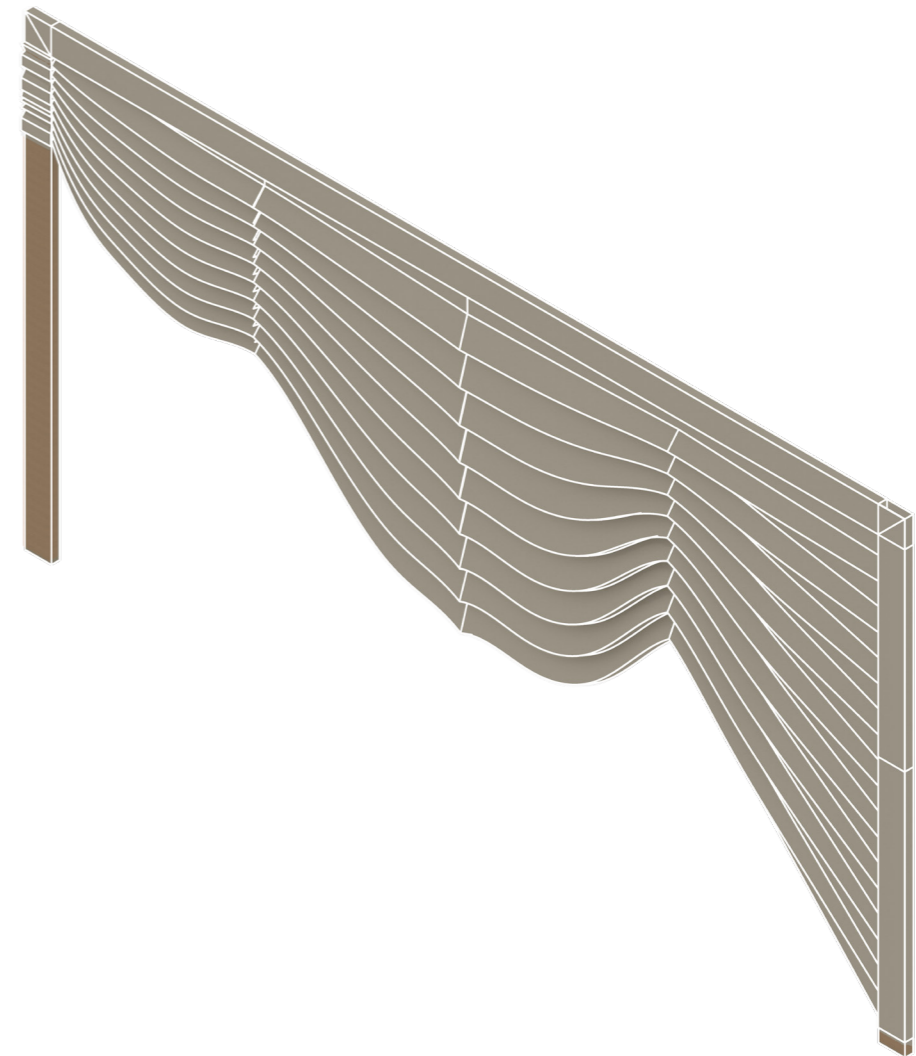

RUCHED ON WOOD

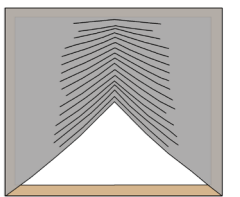

The space divider using the system ruched on wood is made up of a frame of wood with fabric sewn on to it. By ruching together fabric with a thread on certain spots the hybrid can be more or less opened.

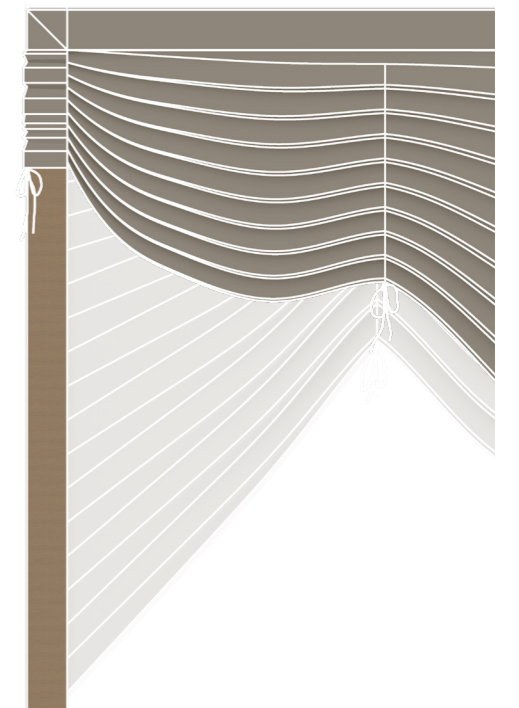

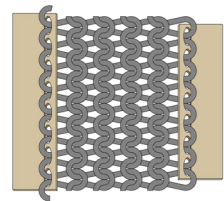
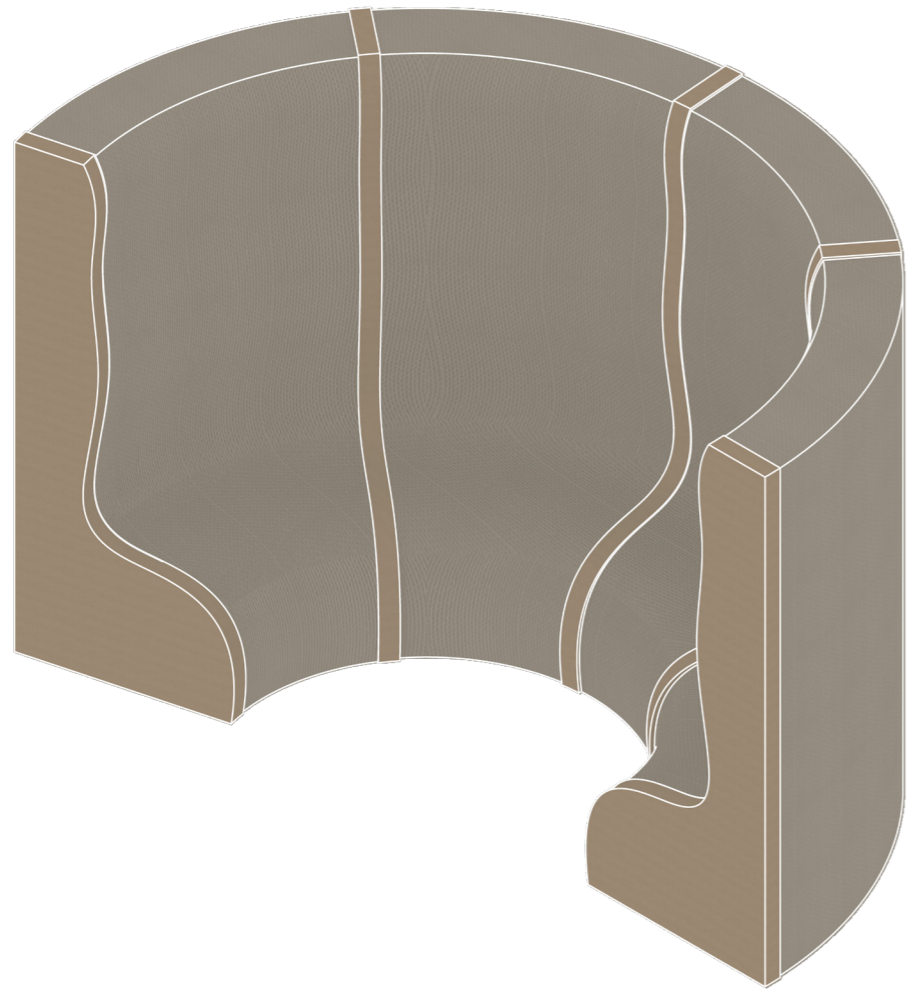

KNIT AND WOOD

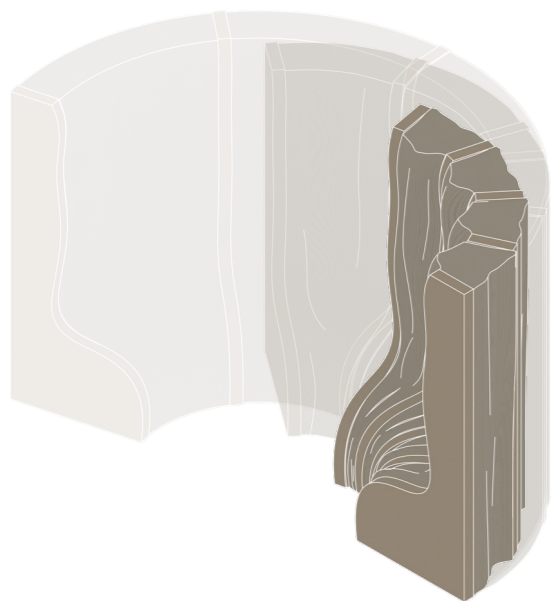

Knit and wood showcased as a system of creating a small room of seating within a larger space. It is a flexible implementation which you can fold in and out.

The wood is formed to create seating on one side and the knitting follows that form.

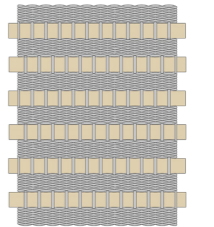
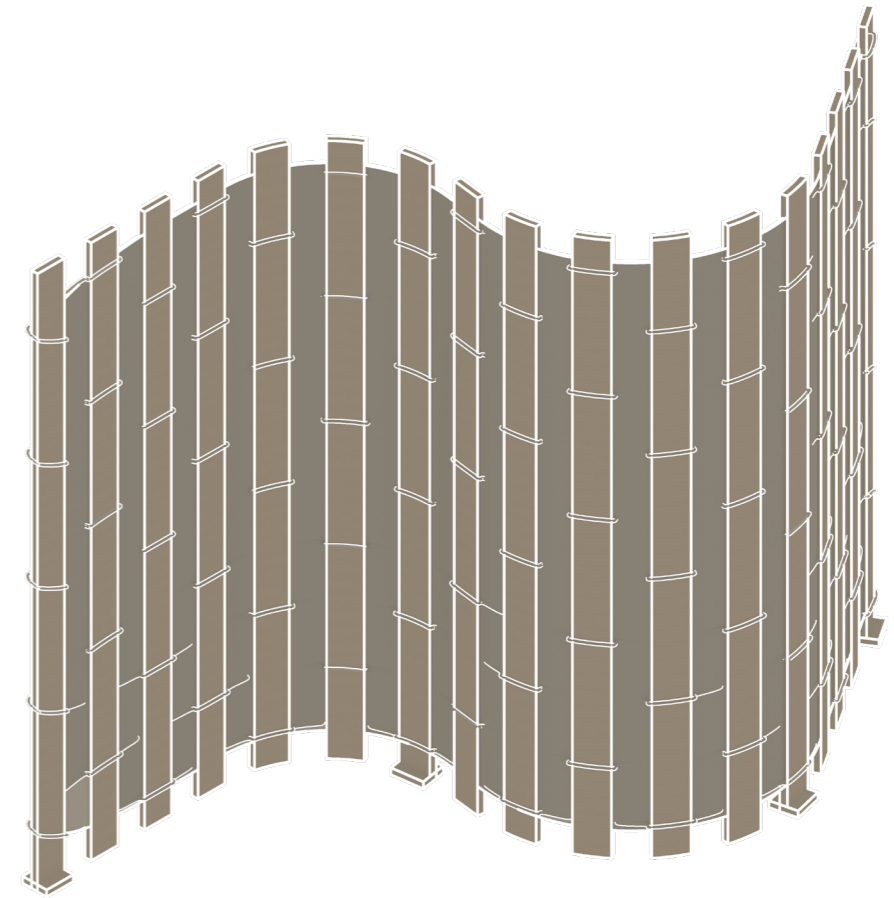

WOOD WEAVE

The space divider of the hybrid *Wood weave* is a pliable parting wall. The wood is woven together by textiles and the planks has feet so that the wall can stand up.

The wall is thin and flexible, the wood is sturdy and holds the wall up but the weave is soft so it can easily be folded or rolled up.

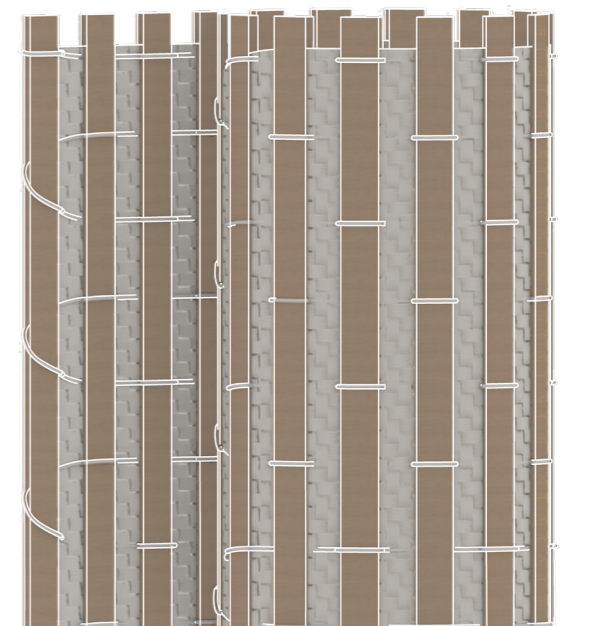

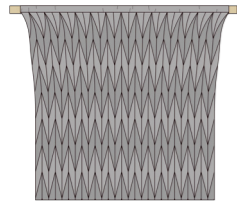
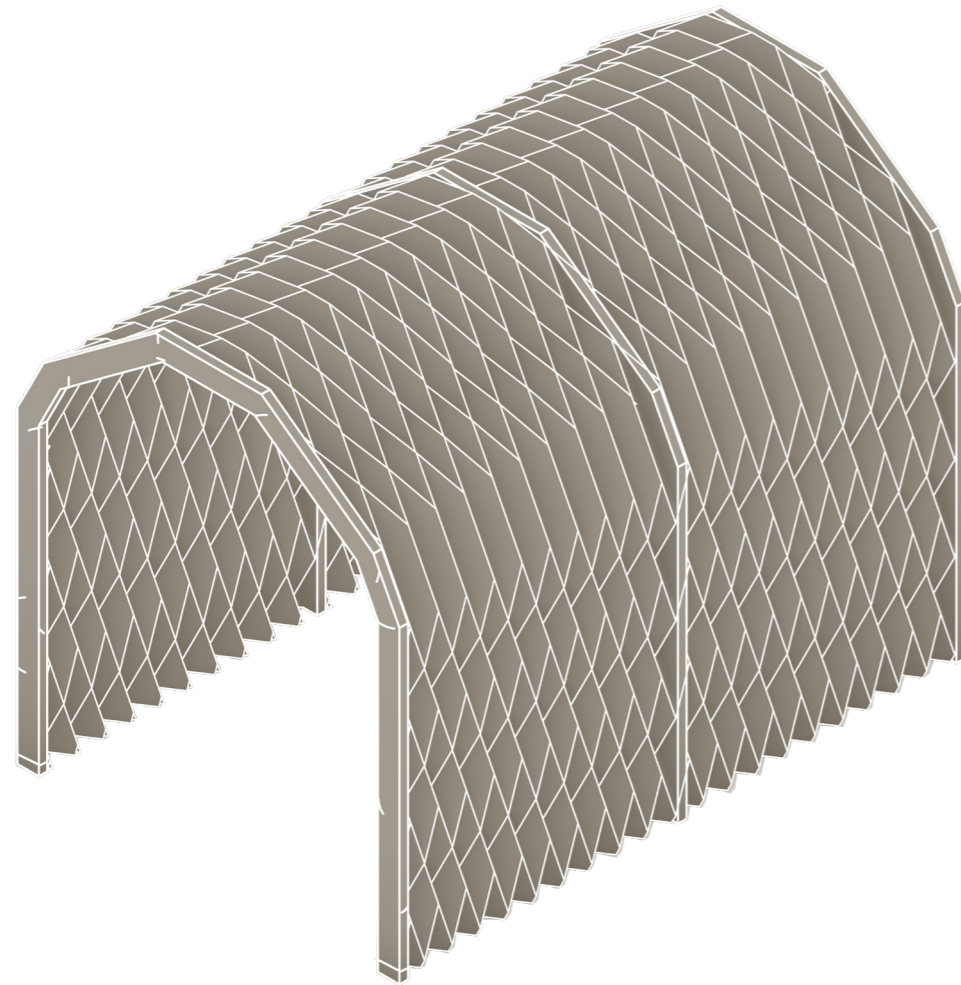

PLEATED WITH WOOD SEWN IN

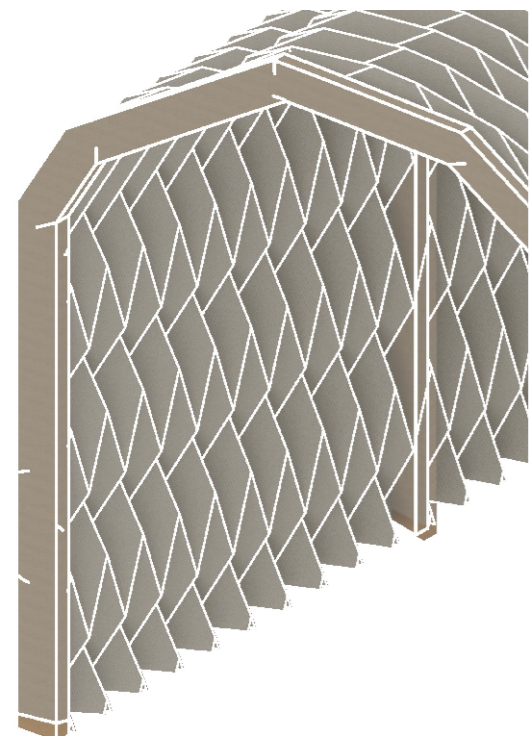

With inspiration from the first explorations and the test called pleated vault the space divider showing the hybrid pleated with wood sewn in is a expandable vault. The pleats creates stability in the fabric which keeps the form of the vault.

The vault can be expanded and elongated until the fabric is almost plane and when pushed together the pleats folds back in to place.

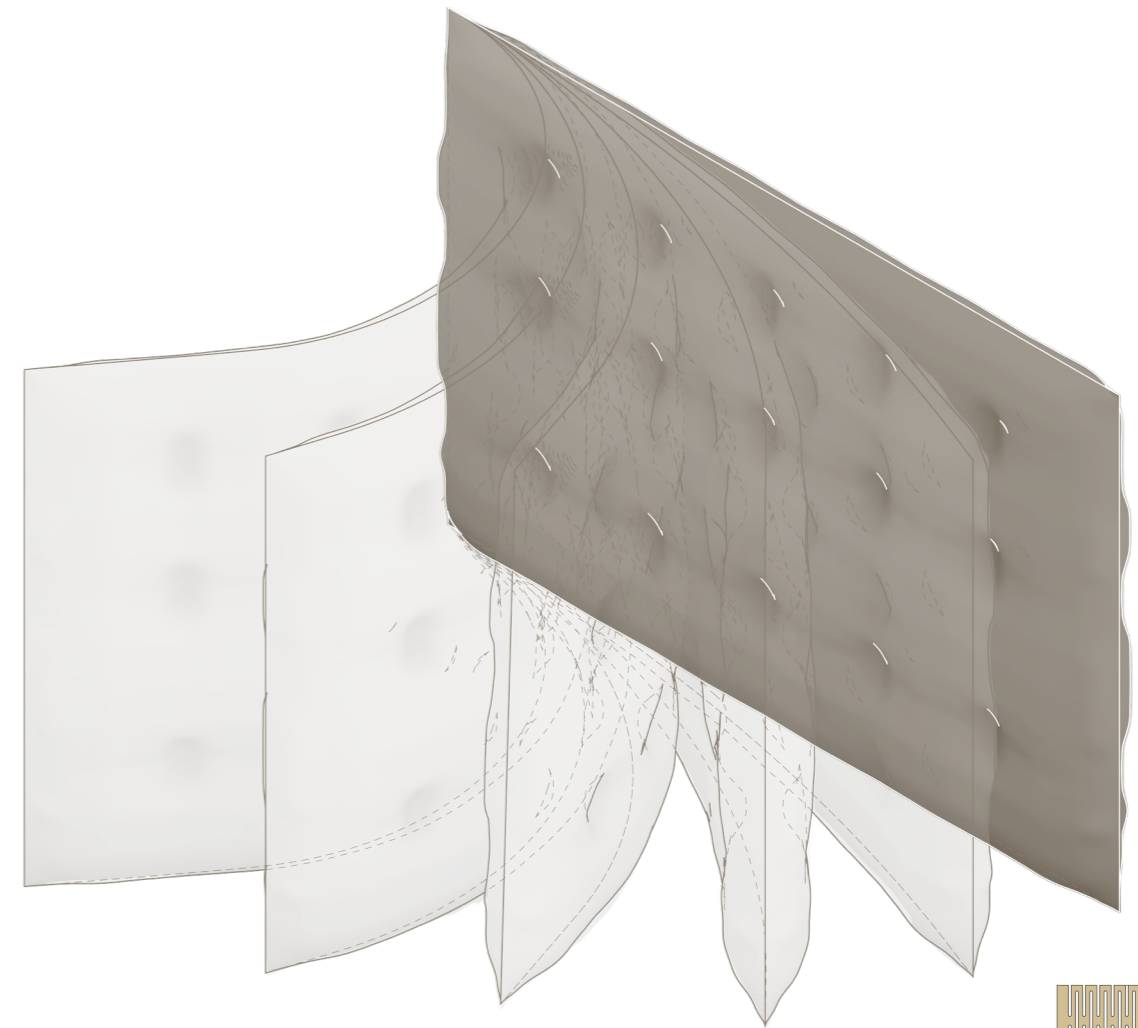

SOFTENED WOOD

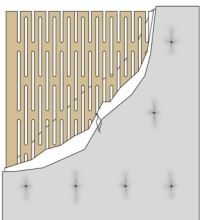

The parting wall using the system of *Softened wood* is created by a CNC milled plywood with a cushioned textile cover. It has a soft cushioned expression and is soft to the touch. The cushion also have a sound absorbing.

The space divider created is bendable but still stiff. It can be used to divide a bigger space. By attaching it to walls or pillars to create a little bit of force the wood will bend but go back to straight if let go.

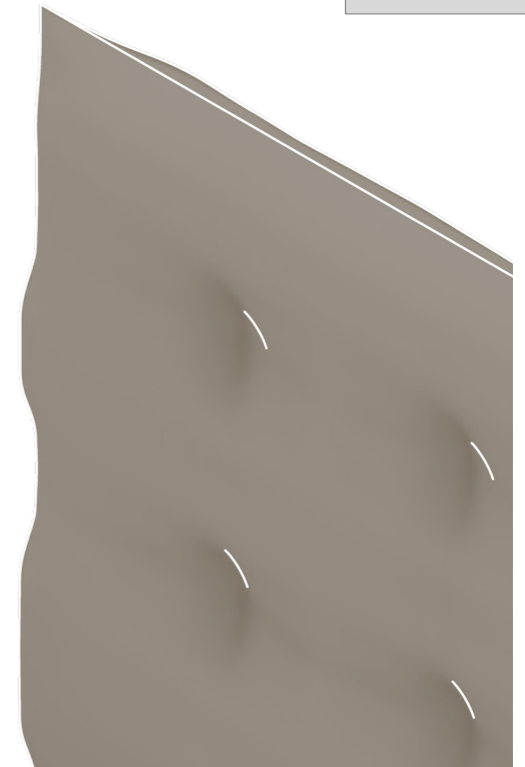

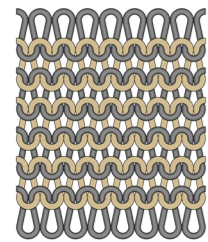
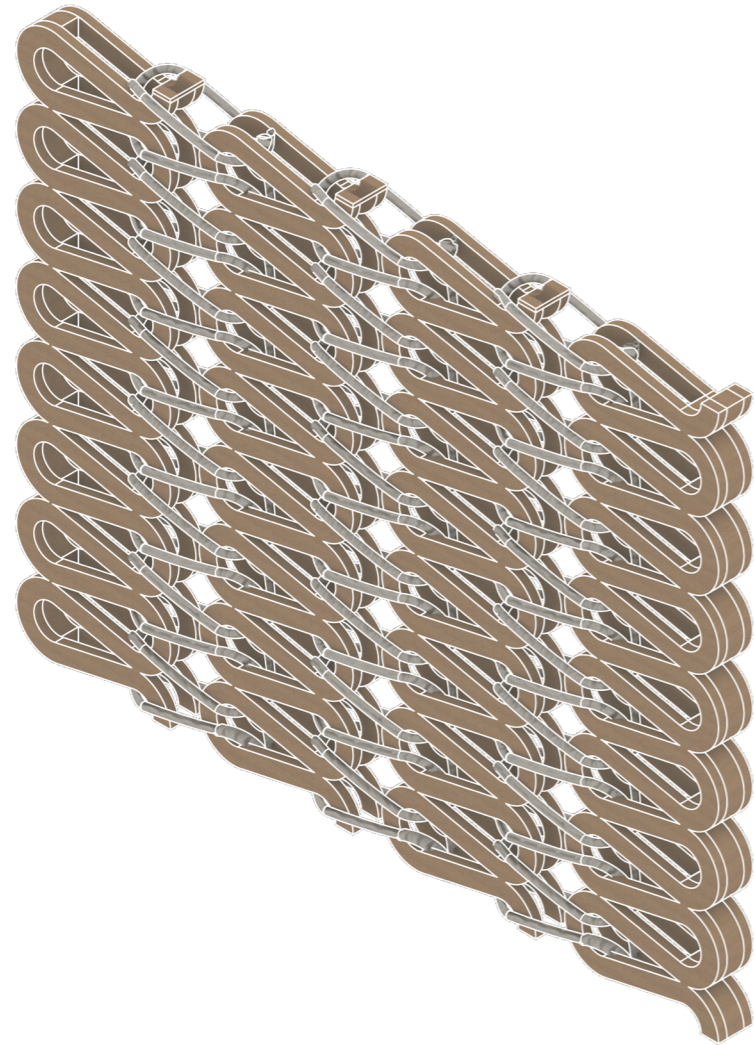

KNITTED WOOD



The wooden loops in the space divider is created by two sides of CNC milled plywood connected in the edges. The loops are knitted together with a thick rope.

The parting wall stands for it self and is flexible and foldable. It is semi see through but creates a clear border in space.

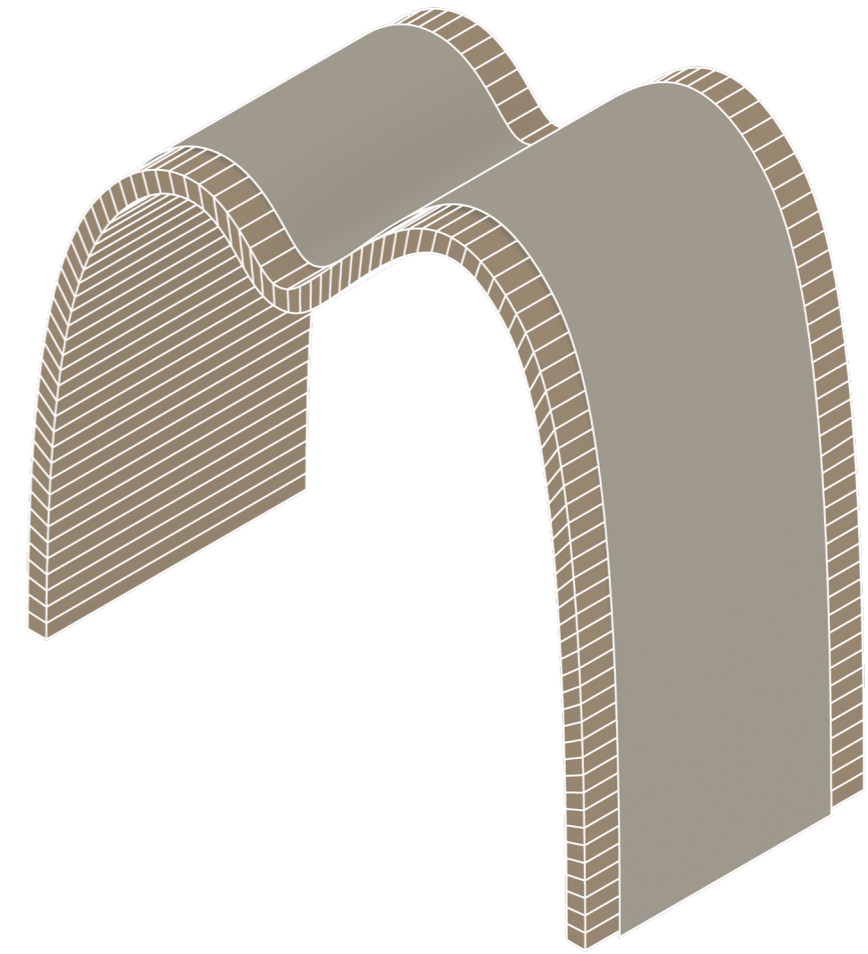

WOOD ON FABRIC

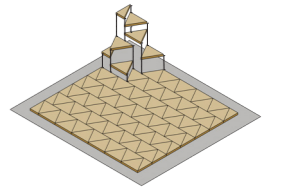

Arch made with the technique from the system Wood on fabric. The arch is made by linear beams that hold together by a fabric. By shaping the beams edges the form falls in to place.

The wooden side creates an arch but turning it on the other side the hybrid can be rolled up and transported or stored.

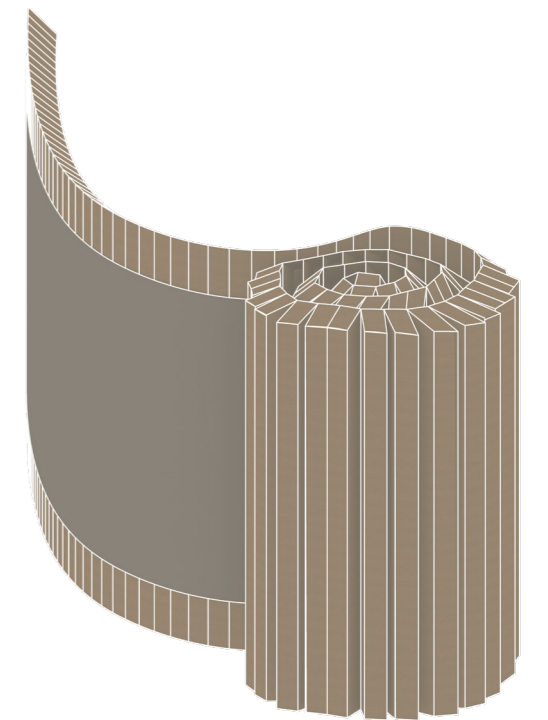

CONCLUSION

DISCUSSION
AND
REFLECTION

CONCLUSION/ DISCUSSION

This thesis has shown that there are many possible ways to combine textile and wood to create architectural effects. Eight different hybrid systems have been developed and thoroughly investigated. They showcase hybrids using different kinds of textile and wood as well as various ways of connecting the two. Depending on the chosen material and connection type the hybrid achieves different architectural expressions.

The **wood** in these elements are varying in complexity. Some are made of simple wooden planks, other are cut out in more complex form. The hybrid Wood on fabric is the most complex need to be CNC milled to have the right angles on the edges to create the specific form.

The **textiles** are also widely varying, ranging from fabrics to yarn and thread. Within these categories the uses are diverse. When using yarn or thread in the hybrid these most often creates a fabric, either knitted or woven, in the process of combining the materials. One exception is Knitted wood where the yarn-like textile is connecting the wooden loops in a knit.

The eight hybrids have different **connections** that can be categorized in three different categories dependent on how integrated the materials are with each other. Some systems the materials are very integrated with each other and connected throughout, like Wood weave or Knitted wood. There are other hybrids where the materials connected only on the edges, for example Ruched on wood and Knitted wood. And lastly there are the ones that not very integrated but where the materials are more one on top of the other like Wood on fabric.

Because the eight hybrids are so varied it is difficult to give a general, summarized conclusion. So, in order to give a comprehensive conclusion and discussion without missing important aspects of the work the hybrid systems will be individually covered. This will touch upon the systems qualities and expressions as well as what the main purpose and potential the hybrids have.

Excessive knit

Excessive knit is a versatile hybrid as the connection between the textile and the wood is quite simple. The excessive amount of yarn used in the process gives the hybrid a voluminous and bulky expression. This also gives room for flexibility within the hybrid, the textile can be more or less stretched out. The wood can have different forms as long as it is narrow such that the yarn can be wrapped around it.

Ruched on wood

The *Ruched on wood* was made to experiment a bit with the dimension and texture of a fabric. It is the one hybrid that is most similar to the membrane textile that usually is found in architecture today. But with ruching and gathering of fabrics the textile itself gets another type of expression.

The focus of investigation in this hybrid is the use of fabric and how the way of ruching together fabric could change the expression of the element. The flexibility in this system is that it can open and close by ruching the fabric together.

A quality that has not been showed in this thesis is that with thoughtful gathering spots you can direct for example water or wind to a specific space with the creases it makes. Something that could be beneficial in for example a roof where rain can be directed to one spot.

Knit and wood

The hybrid system of *Knit and wood* has a lot of potential to be used in different ways. By changing the amount of textile and the shape of the wood this hybrid could take on different expressions and forms. It is a versatile hybrid with an easy connection. The main struggle would be to knit in the wood in the process of knitting, but the connection of the materials could be done after the knit is done by sewing the knitted fabric in place using the holes in the wood.

Wood weave

The hybrid of *Wood weave* is a flexible system where the thread works as a way of connecting the wood while creating a mouldable structure. The part in between the wood creates a textile weave which mainly would be soft and pliable, but the wood gives it stability.

The expression of this hybrid system is quite versatile. The amount of wood and textile can vary which gives the hybrid different expression. By using different type of threads or weaving or tapestry techniques in the woven part is also a way of changing the textile expression in this system.

Pleating with wood sewn in

The *Pleating with wood sewn in* hybrid had the main intention of investigating ways of using the herringbone pleated fabric. By testing different techniques of using the wood the most usable way I tried was to sew it in. This technique made the hybrid versatile as changing the shape of the wood, like bending it or cutting out complex shapes, the hybrid could be used in various ways.

The herringbone pleat has a strong expression and creates dimension to the fabric. The pleating also has a function as the fabric folds back into the pleats when relaxed or pushed together.

Softened wood

The hybrid of *Softened wood* started out as a way of laser cutting plywood to be able to bend and shape it. By covering the plywood with a cushioned textile surface sewn on to the plywood it creates a soft expression. Despite being made from one large piece of plywood the hybrid is still bendable. The main feature with this hybrid is that it is bendable but flattens when no force is given. This could be suitable for something that is temporary or moveable as the flat panels are easy to move or store.

Knitted wood

The expression of *Knitted wood* is graphical and interesting. If you have an interest and knowledge in textiles seeing the hybrid from far the textile expression is clear. But up close and for an “untrained eye” the expression of the hybrid is still strong even though one might not see that it mimics a knitted pattern.

By letting the wood take on the form and expression of a knitted fabric it also takes on some of its qualities. Depending on how the wood is cut it can also be quite bendable which is something that is not explored within this thesis.

Wood on fabric

By gluing or nailing fabric to wooden shapes was a way of exploring the use of fabric in self-supporting modular structures. When I have worked with these structures before one problem has been that some pieces might fall of or that the structure is easy to knock down. But by using fabric all the pieces will be kept in place. The structure will be flexible as it is possible to fold it on the other side as seen on the space divider shown in this thesis.

The system of *Wood on fabric* explores a quite simple hybrid of the two materials in a large scale. The expression of this hybrid might not be as expressive as the others but that just shows that the hybrid systems are diverse.

REFERENCES

Books

Hemmings, J (Ed) (2012). *The textile reader*. Bloomsbury Visual Arts.

Kronenburg, Robert. (2014). *Architecture in motion: The history and development of portable building*. Routledge, Taylor & Francis Group.

Peters, S. (2011) *Material revolution : sustainable and multi-purpose materials for design and architecture*. Birkhäuser.

Semper, G. (2010). *The four elements of architecture and other writings*. (H. F. Mallgrave & W. Herrmann, Trans.; First paperback edition). Cambridge University Press (Original work published 1989).

St Clair, K. (2019). *The Golden Thread*. John Murray Publishers Ltd.

Articles

Cache, B. (2000) *Digital Semper*.

Hörteborn, E., & Zboinska, M. A. (2021). Exploring expressive and functional capacities of knitted textiles exposed to wind influence. *Frontiers of Architectural Research*.
<https://doi.org/10.1016/j.foar.2021.02.003>

Quinn, B. (2006) *Textiles in architecture*, John Wiley & Sons

Websites

Nationalencyklopedin, textilier. <http://www.ne.se/uppslagsverk/encyklopedi/lång/textilier> (retrieved 2021-04-23)

Nationalencyklopedin, trikå. <http://www.ne.se/uppslagsverk/encyklopedi/lång/trikå> (retrieved 2021-04-24)

Nationalencyklopedin, textilfiber. <http://www.ne.se/uppslagsverk/encyklopedi/lång/textilfiber> (retrieved 2021-04-24)

Nationalencyklopedin, vävning. <http://www.ne.se/uppslagsverk/encyklopedi/lång/vävning> (retrieved 2021-04-26)

Interaction Green (2018) <https://www.interactiongreen.com/kengo-kuma-exhibition-lab-materials-wood/> (retrieved 2021-04-27)

Interaction Green (2018) <https://www.interactiongreen.com/kengo-kuma-exhibition-lab-materials/> (retrieved 2021-04-27)

Pritzker Prize, (n.d) <https://www.pritzkerprize.com/biography-frei-otto> (retrieved 2021-04-28)

Images

Images without source is taken or created by the author of this thesis.

Image 1

Dennis Gilbert. Wildscreen World at Bristol, Bristol, United Kingdom, Hopkins Architects. [Photograph]. Retrieved from Encyclopædia Britannica ImageQuest. https://quest.eb.com/search/104_322296/1/104_322296/cite (retrieved 2021-04-25)

Image 2

準建築人手札網站 Forgemind ArchiMedia. (2015) 隈研吾 Kengo Kuma - *The One 南園* 風簷裝置藝術 02 [Photograph] Licensed with CC BY 2.0. Flickr <https://www.flickr.com/photos/eager/16205958910/in/photostream/> (retrieved 2021-05-08)

