



URBAN MYCELIUM FARMS

Bio-mycorrhizal development as community catalyst

Ala Talebian & Alonso Francisco Martínez Díaz
Architecture and Planning Beyond Sustainability | MPDSD
Chalmers University of Technology 2024
Examiner: Meta Berghauer Pont
Supervisors: Marco Adelfio & Carl-Johan Vesterlund

Master Thesis
Spring 2024



Pleurotus ostreatus mycelium cultivate at home. (Own authorship)

MYCELIUM URBAN FARMS
Bio-mycorrhizal development as community catalyst

A master thesis by Ala Talebian & Alonso Francisco Martínez Díaz

© Ala Talebian & Alonso Francisco Martínez Díaz, 2024

Contact: alonsof@chalmers.se | talebiana@chalmers.se
Telephones: +46 (0) 70 476 30 22 | +46 (0) 72 786 05 14

Chalmers University of Technology
Department of Architecture and Civil Engineering
Direction of Urban and Rural Design and Planning
Master Programme of Architecture and Planning Beyond Sustainability
Examiner: Meta Berghauer Pont
Supervisors: Marco Adelfio & Carl-Johan Vesterlund

412 96 Gothenburg, Sweden | 2024

Frontpage illustration by authors



CHALMERS
UNIVERSITY OF TECHNOLOGY

ACKNOWLEDGEMENTS

First, we want to thank our supervisors: Marco Adelfio and Carl-Johan Vesterlund. Marco, who has vitalized the idea that society and community are some of the greatest actors in cities, guiding us to convey and express more clearly our passions and work in this thesis, to his patience and critical-positive feedback. Carl-Johan, through his reflections and expertise, has made the evolution of our ideas a rich and nurtured substrate, to explore new concepts and paths that led us to a more complete research.

Also, we want to thank Meta Berghauser Pont, our examiner; who has been an example of diligence and curiosity, showing us that a different way of making cities is possible, a path where all the systems can work in synergy and harmony. Her leading character and unbiased assessment have taken shape in our investigation, trying to reach a wholesome and holistic outcome.

Special thanks to BYGAARD for warmly welcoming us into their farm, allowing us to work alongside them despite their busy schedule, and generously sharing their knowledge and even their food with us. Their expertise in the field greatly inspired many of the design ideas.

As well, we also want to thank our families, who have always motivated our will to keep on learning, exploring and never giving up on our dreams. They gave each one of us strong motivation, help, love, and support to reach this far.

And finally, thanks to each other, thesis partners and friends. We explored, we feared, we struggled, we laughed, we enjoyed, we worked, we learned, we innovated, we strived, and finally reached. Thanks to ourselves, we made it!

STUDENTS BACKGROUND



ALONSO FRANCISCO MARTINEZ DIAZ

Bachelor studies

Guadalajara, Mexico | ITESO 2010-2015

Certificate studies

Guadalajara, Mexico | ITESO 2018
Diploma in landscape architecture

Work experience

Guadalajara, Mexico | 2015 - 2021

Fields:

Structure design
Public works & landscape design
Architecture residential design & BIM design

Master studies

Gothenburg, Sweden | Chalmers 2022-2024

Courses:

Sustainable development and the design professions
Design and planning for social inclusion
Design systems
Social-ecological urbanism
Urban prototypes

Research

Gothenburg, Sweden | Chalmers 2024 -

Job:

Student Research Assistant at
The Spatial Morphology Group (SMoG)



ALA TALEBIAN

Bachelor studies

Tehran, Iran | University of Tehran 2017-2021

Work experience

Berlin, Germany | 2019

Field:

Residential architecture design

Tehran, Iran | 2021

Field:

Archaeological related architecture design

Master studies

Gothenburg, Sweden | Chalmers 2022-2024

Courses:

Sustainable development and the design professions
Design and planning for social inclusion
Design systems
Transformation projects and environmental care
ERASMUS programme at TUBerlin - Climate resilient urban soils



ABSTRACT

Fungi play a major role as transformers and decomposers of nutrients in ecosystems, contributing to carbon, nutrient cycling, and climate regulation. Particularly, mycorrhizal fungi develop symbiotic connections with plants through root systems called mycelial networks -these networks facilitate the transfer of nutrients, stimulate interspecies communication, and strengthen soil health conditions. Due to the existing climate emergency and accelerated development, it is paragon to find entities that perform similar processes fungi do by translocating its benefits to an urban scale. This thesis aims to achieve this through Urban Mycelium Farms, leaving behind the idea of pushing away production systems from city centers. Cities as drivers of global change, must prioritize reuse and cycle of waste, foster stronger and participative multiple-stakeholder communities, promote healthier urban environments, and create a culture of environmental awareness. Moreover, they must take into account metabolic flows, urban, architectural, and social values aligned with principles of urban symbiosis.

In this thesis, we propose using fungi and mycelium to build the concept of Urban Mycelium Farms, which focus on producing mycelium and fungi by upcycling waste resources. These farms reposition urban symbiosis into the city's social fabric, working as a community catalyst; considering social-ecological characteristics, and creating a new bio-based, community-oriented, co-created, and inclusive development path in urban clusters.

Methodologically, we identify and establish through literature studies, research, interviews, spatial analysis, and design the necessary elements and conditions to implement Urban Mycelium Farms. We take Gothenburg city and Landala district as case study locations, using coffee waste as a resource for production and analyzing the effects of this farm on the urban space and society.

As a final output, this thesis develops spatial conditions and design strategies that can be used for further mycelium farm designs and explorations. We additionally develop an example of a mycelium farm; its design in terms of space, spatial distribution, resource processes, and mapping of social interactions.

Keywords: Mycelium - Urban Farming - Urban Symbiosis- Biobased Development - Social-ecological Urbanism - Sustainable Urban Development- Urban Mycelium Farms- Mushroom Farming

INDEX

AKNOWLEDGEMENTS
STUDENTS BACKGROUND
ABSTRACT
GLOSSARY

INTRODUCTION

13-25

- 1.1 MOTIVATION
- 1.2 PROJECT SCOPE
 - Subject & problem description
 - Aim
 - Conflict
 - Scale
 - Research question & operational questions
 - Objective
 - Link: Conflict-context
 - Delimitations
- 1.3 SUSTAINABILITY RELEVANCE
- 1.4 METHODOLOGY

THEORY & CONCEPTS

26-44

- 2.1 THEORETICAL FRAMEWORK
 - Theories
 - Biophilic Design
 - Social-Ecological Urbanism
 - The Co-Produced City
- 2.2 STATE OF THE ART: MYCELIUM, URBAN MYCELIUM FARMS AND ITS COMPONENTS
 - Mycelium and its role in ecosystems
 - Mushroom and mycelium in relation with humans
 - The roles of an Urban Mycelium Farm in supporting social and ecological processes
 - Types of Urban Mycelium Farms
 - Stakeholder composition
- 2.3 SPATIAL REQUIREMENTS
 - Generic spatial requirements
 - Specific spatial requirements
- 2.4 DESIGN STRATEGIES

REFERENCE PROJECTS

45-55

- 3.1 MYCELIUM FARM
 - Permafungi
 - La Boite a Champignon
 - La Caverne
 - BYGAARD
 - Amisacho
 - RoterZwam
 - Hut & Stiel
 - Epaphroditus Women's Cooperative, Africa
 - Development Promise
- 3.2 OWN PROJECTS
 - Alonso: Urban Mycelium Farm, Gamlestaden
 - Ala: Common waste, Common Resource, Berlin

DESIGN PHASE: LANDALA CASE STUDY

56-93

- 4.1 THE ROLES OF LANDALA URBAN MYCELIUM FARM
- 4.2 THE STEPS IN THE DESIGN PROCESS
- 4.3 SITE ANALYSIS
 - Location & Objective
 - Accessibility
 - Connectivity
 - Density & Betweenness
 - Land uses
 - Public spaces
 - Space analysis
 - Resource mapping & angular integration
- 4.4 DESIGN PHASE
 - The involved stakeholders
 - Governance
 - Stakeholder analyses & spatial conditions to grow mushrooms
 - Design strategies to transform the public spaces and interior of building
 - Spatial conditions
 - Landala Urban Mycelium Farm, designing with a parking lot
 - Landala Urban Mycelium Farm Plan zoning
 - The space through collages

CONCLUSIONS & REFLECTIONS

94-98

APPENDIX

99-107

- INTERVIEWS
 - Leonardo Rosado
 - Divia Jimenez Encarnacio
- BYGAARD
- MYCELIUM TESTING

LIST OF FIGURES

108-110

BIBLIOGRAPHY

111-115



«We learn everything from how nature organizes itself. There is such an interdependence. A tree does not live alone , not even a small plant or organism; it is about collective knowledge and making sure that the others survive so I can survive»

-Rachel Rosenberg
From the book «Let's become fungal!»

GLOSSARY

Mycelium:	Root-like structure of a fungus consisting of a mass of branched, thread-like tubular filaments called hyphae.
Mycorrhizal/Mycelial network:	Underground network found in forests and other plant communities, created by the hyphae of fungi joining with plant roots. This network connects individual plants creating associations that are multifunctional for the translocation of nutrients and signaling compounds which affects the composition and fitness of both mycorrhiza and plant community, enhancing their nutrient access, and stress tolerance creating sharing-communication channels to increase survival opportunities among individuals.
Urban mycelium farm:	Repurposing green spaces, urban voids, or other areas within a city or heavily populated zone to urban farms that focus on producing mycelium, mushrooms, and mycelium-related products with various purposes such as food production, material innovation, research, or prototyping by upcycling waste resources.
Urban symbiosis:	Strategy for optimizing the urban metabolic system, resource efficiency through local/regional collaboration, and reducing environmental impact. It engages traditionally separate urban systems in a collective approach to competitive advantages involving the physical exchange of materials, energy, water, and/or by-products. Key to this symbiosis is collaboration and the synergistic possibilities offered by geographic proximity, increasing the value of businesses, stimulating innovation, improving environmental and sustainability performance, and fostering local and regional development.
Social-ecological urbanism:	Concept for understanding the intertwined nature of human and natural systems in this new, interconnected, and interdependent way. Social-ecological systems are therefore not merely social plus ecological systems, but cohesive, integrated systems characterized by strong connections and feedbacks within and between social and ecological components that determine their overall dynamics.
Biophilic design:	Design model that integrates into a broader network of social and biological interactions that need to be in balance to create healthier environments for all species including us. This design approach translates the natural human affinity to relate to natural processes and systems (biophilia) into the design of the built environment.
Co-production:	It's a shift in the power relationships around services and production. In the urban context, it's about how public spaces are to be met and the citizen's right to the city: how to occupy space and decide how it is developed, managed, and used.
Angular betweenness:	A measure of centrality in space syntax. It analyses how many shortest paths between every point to all other points in the system pass through each segment within a certain radius. Is an indicator of the flow of people one can expect in each street. It is based on the street's position in the street network.
Angular integration:	A measure of centrality in space syntax. It measures how close each segment is to all others in terms of the sum of angular changes that are made on each route. It is an indicator of how connected a street is to the rest of the streets in the whole network.



«Cities have the capability of providing something for everybody, only because, and only when, they are created by everybody»

-Jane Jacobs

1.1 Motivation

Ala

Back in June 2023, I started researching topics, looking at case studies, and writing my interests in the hope of finding a concrete topic for my master's thesis. That did not go as planned. Feeling lost, I traveled to Iran, seeking inspiration from its traditional architecture.

During my visit, I was astonished by the pigeon towers scattered across the landscape in Isfahan. These structures are designed to accommodate pigeons and make use of their feces as fertilizer. They represented a sustainable cycle of food production deeply rooted in the local environment and that fascinated me.

Inspired by this experience, I went to explore ways to integrate food production into urban spaces and foster a closer connection between humans and nature. Using design, I aspired to come up with a catalyzer and create a new role within the urban context, the same way pigeon towers are empowered to change their surrounding. I envisioned a new approach to urbanism that prioritized sustainability and community well-being. Once again I started researching but this time specifically about subjects that reflected these aspirations. I still did not know how to conduct my ideas or exactly what topic to work on, all I knew was that I wanted it to be related to food, I wanted it to be sustainable, and I wanted to make a new form of urbanism that embraced ecological principles and encouraged residents to engage with their environment.

All the pieces came into place only after a chat with my friend Alonso about his findings and I am glad we had that lunch talk as that was the moment this project was born, and fungi took the role of being my catalyzer of change.



Pigeon towers, Isfahan Province, Iran. (Own authorship)



Jonsered's Nature Reserve, Gothenburg, Sweden. (Own authorship)

Alonso

My drive behind this thesis stems from a continuous connection of passions in life. I did not know exactly how I wanted to contribute, but I found the inspiration in the woods, while walking in Jonsered's nature reserve, and saw a mushroom popping out from the ground.

I also attribute it to a sound affinity for sustainability and environmentalism, deeply ingrained in how marvelous nature and all living beings that surround us are. I care about life and that same way of thinking is paired with the idea of veganism, the belief that our development as a species does not have to depend on animal exploitation to thrive.

I am conscious that we are bound to development, but the way we have reached it so far has come to a point of danger; where anthropocentrism, unawareness, oppression, competition, and capitalization have been leading the world with capital letters. I learned that architecture is a powerful way to change the current situation and that my proposals and designs as an architect are political statements that can contribute to a change of paradigm. I found fascination in urbanism, where bigger and broader scales can shape the way cities unfold, cities that work as the canvas of our development as a society. I understood that if I want to change the way we function and develop into something that includes and champions the things I love, I ought to create cities and connections that include all the values and things I care for.

So it is about production, environment, love, urbanism, connection, ethical economy, cooperation, a new bio-based ethical revolution, about cities and models that are rooted in these values, and this thesis is where all those passions connect.

1.2 Project Scope

Subject & problem description

Aim

This thesis aims to give insight and explore the importance of implementing a co-production farm in cities: Urban Mycelium Farms. These farms are meant to be developed in metropolitan areas, leaving behind the idea of pushing away food and other production systems from city centers, relegating them to rural or ru-urban areas, with the premise of delving into a new integral bio-based path of development that will contribute to stronger and more connected social dynamics, paired with environmental awareness and resource management.



Fig 1.1. Concept. (Own authorship)

1.2 Project Scope

Subject & problem description

Conflict

Currently, cities are experiencing unprecedented rates of growth and expansion (UN, 2018) (Fig. 1.3) that in most cases are aligned to linear economy models that no longer pair with the sustainable goals these are demanded to follow. Besides, the isolation, unawareness, and lack of education existing in the global population are partially caused by anthropocentric and individualistic perspectives, that consequently lead to more pressure on the environment and natural resources, compromising our social, economic, and demographic existence. (WWF, 2022) (see Fig. 1.4)

Therefore, solutions to these threats can no longer rely on isolated answers serving a singular purpose in a determined stage of time; instead, these solutions must be structured by multi-scalar and holistic frameworks that provide immediate results to these threats and also offer long-term action plans. These solutions must tackle future possible hazards and simultaneously redefine concepts of growth, civic interactions, education, economy, and environmental interdependency, thus creating new frameworks of development that today's world circumstances require.

Scale

The implementation of this thesis project is mainly local-based, where neighborhoods, residents, and service providers are on the first line of involvement; when scaling up, the project unfolds around a systemic perspective that focuses on an interconnective way of organizing the production and development of local production and the economic processes in between, stemming from mycelium farming (see Fig. 1.2).



Fig 1.2. Scales of involvement, space and connections. (Own authorship)

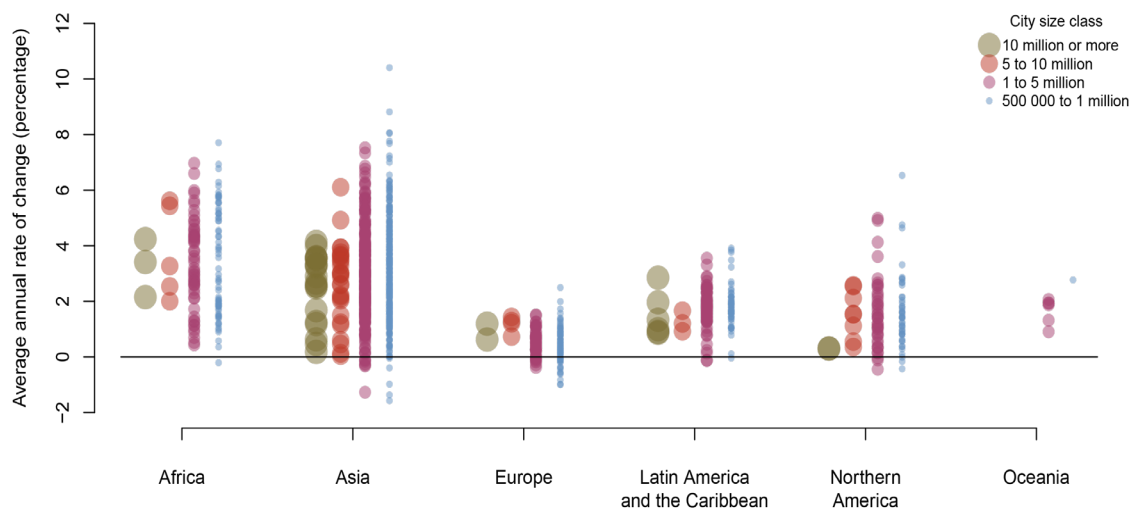

Fig 1.3. Growth rates of world's cities, 2000-2018. (UN, 2018)

1.2 Project Scope

Research question & operational questions

The main drive for our research question comes from our aim of implementing a new co-production model in the urban context: Urban Mycelium Farms.

This study has one main research question that gets answered by six operational questions that guide us throughout our process. Chart 1.1 shows the relationship between the main research question, operational questions, and the principles we used to tackle these questions.

From our research question, we get to our main objective for this thesis, which is reaching spatial conditions and design strategies that lead to the development of one successful example of an urban mycelium farm that repositions urban symbiosis into the city's social fabric, working as a community catalyst; considering social-ecological characteristics, and creating a new bio-based, community-oriented, co-created, and inclusive development path in urban clusters.

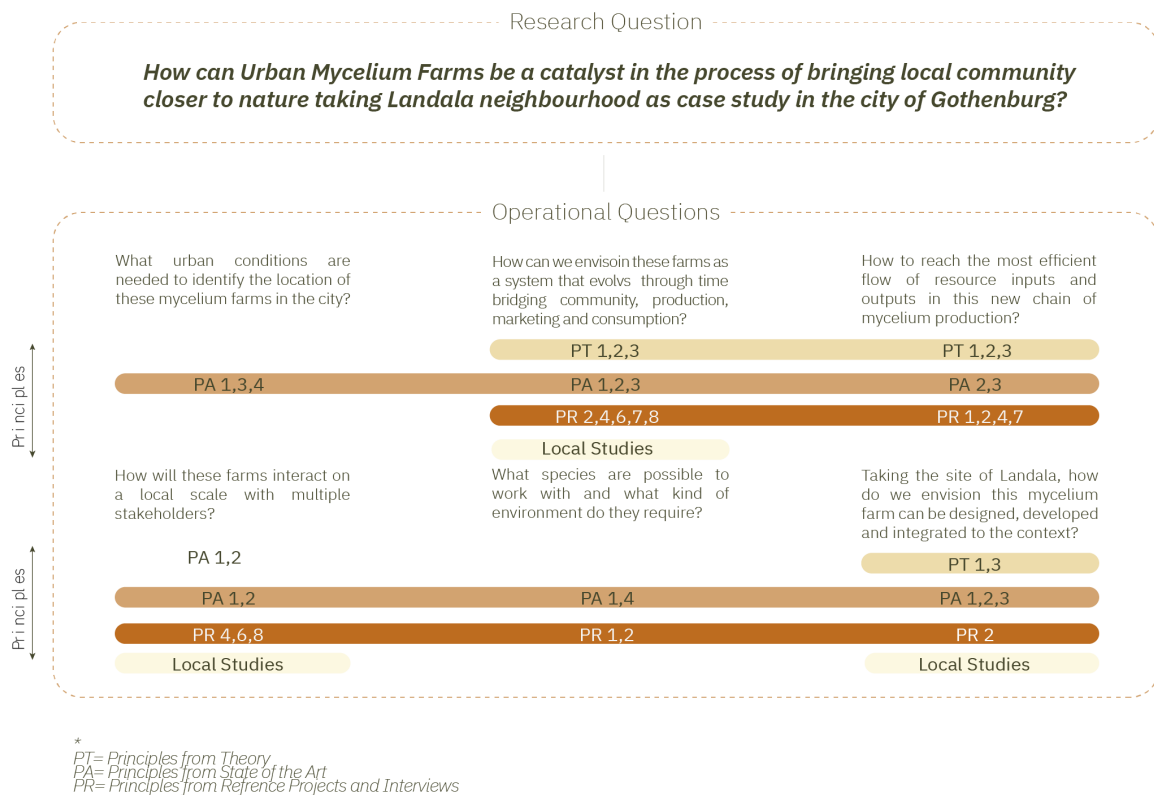
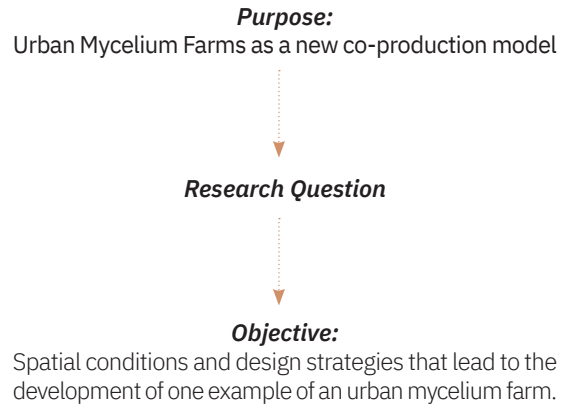

Chart 1.1 Main question, operational questions and principles employed to solve the questions. (Own authorship)

1.2 Project Scope

Objective

The objective of this thesis is to explore spatial conditions and design strategies that can be used for further design and development of mycelium urban farms. Additionally, an example of an urban mycelium farm; its design in terms of space, spatial distribution, resource processes, and mapping of social interactions is developed.

1.2 Project Scope

Link: conflict/context

Bridging urban and natural environments has never claimed more relevance than nowadays. Not only in terms of immediate responses to climate emergencies we face but also in changing the way we establish relationships with nature and other living beings, this last one being a paragon of relevance in the upbringing of human beings and the way we relate to them in adulthood (see Fig.##). That is why, this thesis seeks to contribute to bringing natural processes closer to people in the urban context, building new connections between society, the urban built environment, and nature, and placing these nodes of interaction in high-density clusters of the cities.

From a broader perspective, Urban Mycelium Farms will function as catalyzers trying to reshape and strengthen human-nature interactions (see Fig.1.5) that can exponentially scale up into multiple effects on human behavior (Kellert, S. R., & Heerwagen, J. H. 2008) and production. The intent is to reposition the ecosystem and its services in the core of society's progress, starting to create a different way of understanding that we can have symbiotic relationships with the environment and not just see it as a means to reach anthropocentric goals. In this sense, mycelium farms strive to adapt to the social and urban local needs; incorporating attributes of co-production, waste management, study, awareness, and reproduction of fungi species through bio-based solutions.

These contextual conditions will be categorized and mapped within the Landala district, spotting areas of opportunity in combination with the farm requirements and its needed connections.

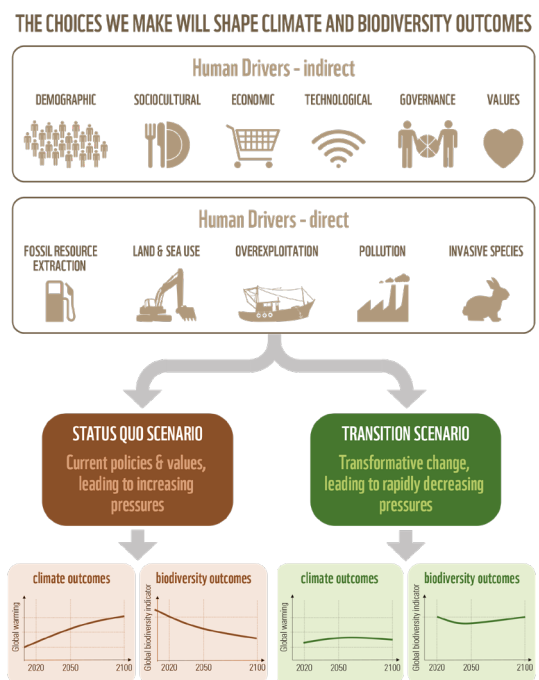

Fig 1.4. Earth's climate, biodiversity and people at a crossroad. (WWF, 2022)

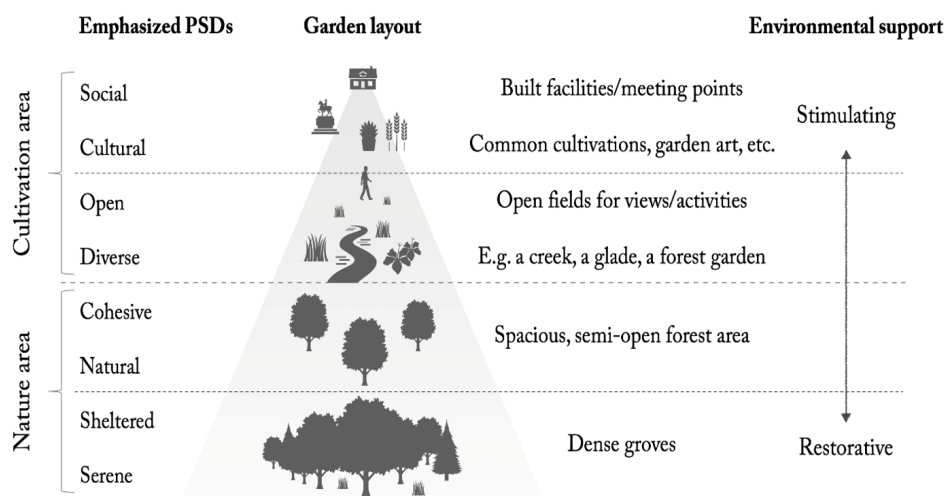
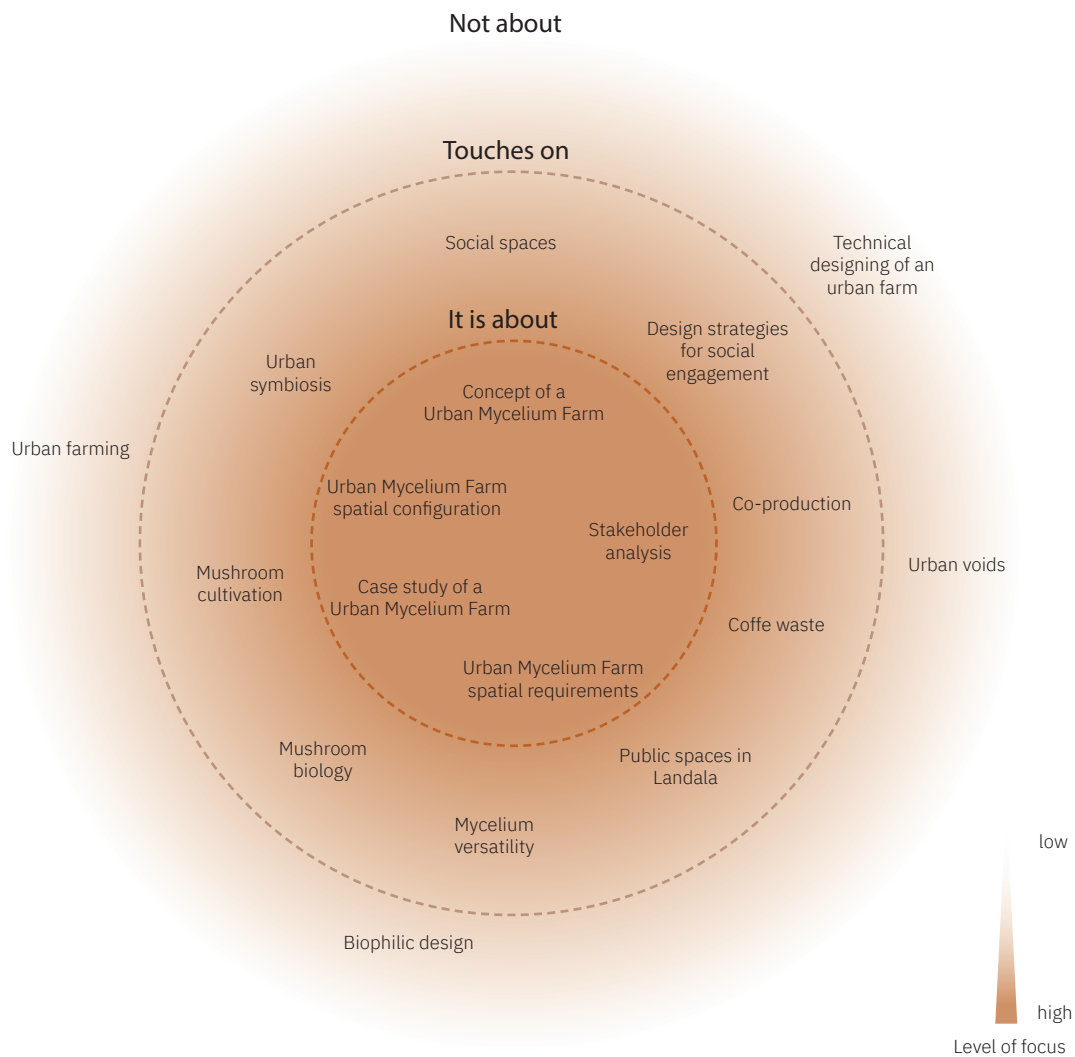

Fig 1.5. Chart showing the impact of nature in human well-being. (Grahn, P. 2023)

1.2 Project Scope

Delimitations



The delimitation of the project ties to the architectural traits of the space needed for mycelium and mushroom production, to the urban and social qualities this production model requires at a neighborhood level adding the possibilities it can reach, and finally to the role and relevance coffee waste has as resource for this farm.

While developing this thesis, we also touched upon the multiple possibilities mycelium can bring, how this new model can be developed in unused or underused spaces in cities, and how this production system can propagate and extend, both as a production space and as a public space with multiple dynamics.

Translating mycelium and mushroom production into architectural and urban subjects made us aware of how vast its reach can be; touching upon many subjects like waste awareness, landscape design, involvement of multiple stakeholders, ecology, participatory design, or sustainable urbanism.

We limit our research to the themes above, but the exploration is open to delve into many other possibilities that can heavily contribute to a more sustainable future in cities and societies stemming from fungi, the natural environment, its processes, and connections.

1.3 Sustainability Relevance

The project has a sound approach to sustainability, focusing on bio-based solutions that depart from fungi, their capabilities, and possibilities for development and research.

In the natural environment, fungi degrade organic matter contributing to soil's health and playing a major role in carbon cycling (see Fig.1.6). We can translocate and translate these carbon cycling capabilities into cities; designing facilities that can deal with organic waste while also generating job opportunities, and creating new production models for food, materials, and other products (see Fig.1.7). All these possibilities are within reach, many projects worldwide are experimenting and thriving around fungi and mushroom cultivation techniques using waste products, showing that these models of development can happen. Many of these projects are located in cities and dense urban areas, connecting and involving multiple stakeholders in the processes of cultivation, production, and manufacturing, showing a glimpse of how these initiatives can remediate and boost social, economic, and environmental aspects in a short and long-term projection.

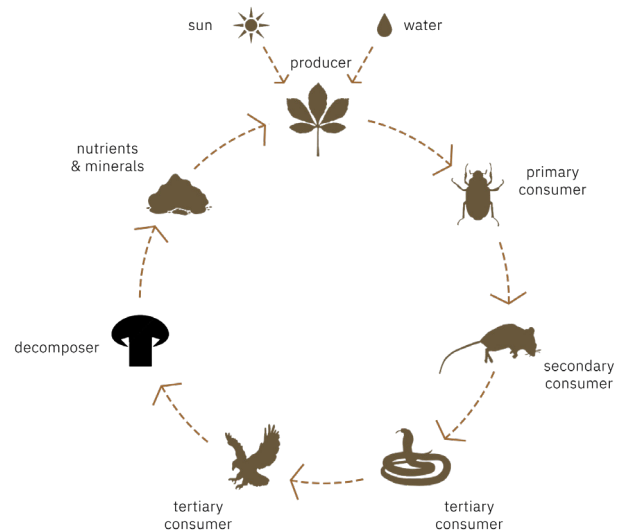

Fig 1.6. Food chain cycle, decomposer as key element. (Own authorship)

Mycelium urban farming intends to address notions of food sovereignty, promoting sustainable agriculture and enhancing local-based food production (Péchar, C. 2009). It covers aspects of education, aiming for quality learning procedures that reformulate paradigms of how childhood, youth, and other sectors of society relate to the natural environment and economic processes (Jaquet, J. 2014). Opens possibilities for decent and inclusive job opportunities reliant on community-supported approaches and eco-efficient management (CAL, 2021). It also brings in the combination of civic participation and reinforcement of cultural and local natural heritage, drawing on effective waste-resource (TED, 2008) planning and taking advantage of urban spaces that gradually are and will stop to comply with their current purposes, readapting and opening up new possibilities of urban growth (Gertz, J., 2017). As previously seen, mycelium and mushrooms address multiple scenarios that take place in our existing cityscapes, and many more can be envisioned in future development perspectives, ranging from material research and innovation to spaces of communal awareness, progressively integrating population in social, economic, and environmental dynamics that we all share and are affected by.

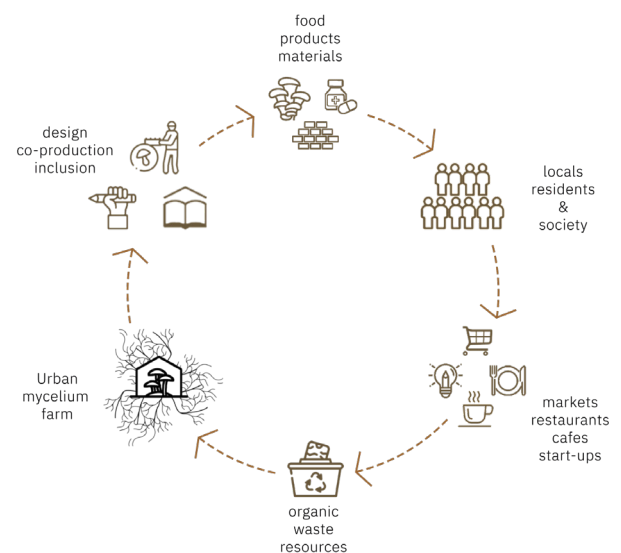

Fig 1.7. Resource flow in mycelium farming, mycelium farm as key element. (Own authorship)

1.3 Sustainability Relevance

The thesis ties closely to The 2030 Agenda for Sustainable Development, linking the mycelium farms with concrete problematics that we observe based on the situations faced by reference projects and personal observations. After identifying the issues, we aligned them with the specific targets we envision the farms will help to tackle corresponding to individual sustainable development goals (UN, 2015)(Fig.1.8).

Since our project extends from studies around space, the built environment, and its connections in an urban context, we established a relation with Sustainable cities and communities goal touching upon 4 targets: **participatory planning**, as we envision these farms to not only work as hubs of co-production for the community in the context they are placed but also public spaces where multiple civic dynamics take place; **safeguard natural and cultural heritage**, because we draw our project on already existing local practices of Swedish culture regarding urban farming (Rosengren, 2012), neighborhood colonies (Slottsskogskolonien, 1916) together with local fungi species; **strengthening of regional development planning**, by involving multiple stakeholders from local government to residents and services; and **resource efficiency**, following an approach of urban symbiosis from source to end-products.

Along the same line, we project the mycelium farms will contribute to industry, innovation, and infrastructure, boosting new startups and businesses founding this development in new bio-based solutions that also open opportunities for research and innovation; in quality education, we see the project as an opportunity to approach society to urban symbiosis practices and awareness about waste management and the natural environment; this is related to responsible consumption and production by efficient management of food waste in different levels consistent with reducing waste generation levels through information and spreading of sustainable practices in society.

At last, we associate the effects of the farms with decent work and economic growth, through diversification of activities in Gothenburg as the sector of this type of farming is still unexplored in comparison with other Nordic cities, inherently mycelium farming relies on circular resource cycles adding the proposal of using urban voids to slow down the process of growth in cities, while at the same time creating job opportunities; finally focusing on zero hunger through small-scale food productivity and a sustainable agriculture system.

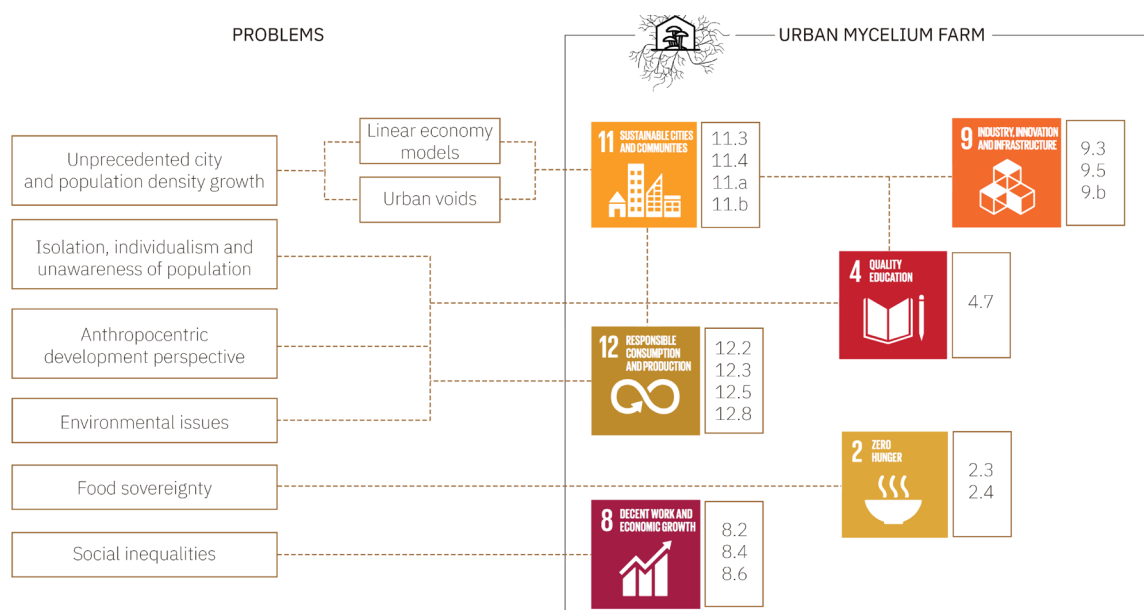

Fig 1.8. Links between problematics and Sustainable Development Goals. (Own authorship)

1.4 Methodology

Research Approach

Research approach

The general background of this research lies on a philosophical pragmatic worldview, holding a qualitative approach during the first phase of the thesis, to later merge quantitative methods during the design phase and back again with qualitative tactics to reach the desired outcome (Chart 1.2). Part of our research unfolds around speculative thinking (Huang, Lu et al., 2021), envisioning, proposing, and suggesting different possible future scenarios through design strategies and the toolkit.

In the first stage of the process (research for design), we will delve into a literature review to build a theoretical knowledge framework and study the state of the art of our topic. Later we apply causal-comparative methods and survey research to develop a phenomenological investigation and contrast reference projects of mycelium/mushroom farms along with interviews with professionals and their insights in the matter.

In the second stage (research by design), through a case study, we develop local studies, and establish stakeholder interconnections and context conditions that help build our design. Then we combine the conclusions from this phase with previous steps and spatial requirements resulting in design strategies that will be part of our toolkit.

Research for design	Research by design
[QL] Literature studies	[QT] Mapping and local studies (QGIS)
[QT] State of the art	[QL] Sketch design proposal (local scale)
[QL/QT] Site visit	[QL] Model making (urban and local scale)
[QL] Site analysis & stakeholder mapping	[QL] Experimentation with mycelium and waste (local scale)
[QL] Reference projects	[QL] Visualizations
[QL] Interviews	[QL] Diagrams

QL= Qualitative tool
QT= Quantitative tool

Chart 1.2 Quantitative and qualitative tools chart. (Own authorship)

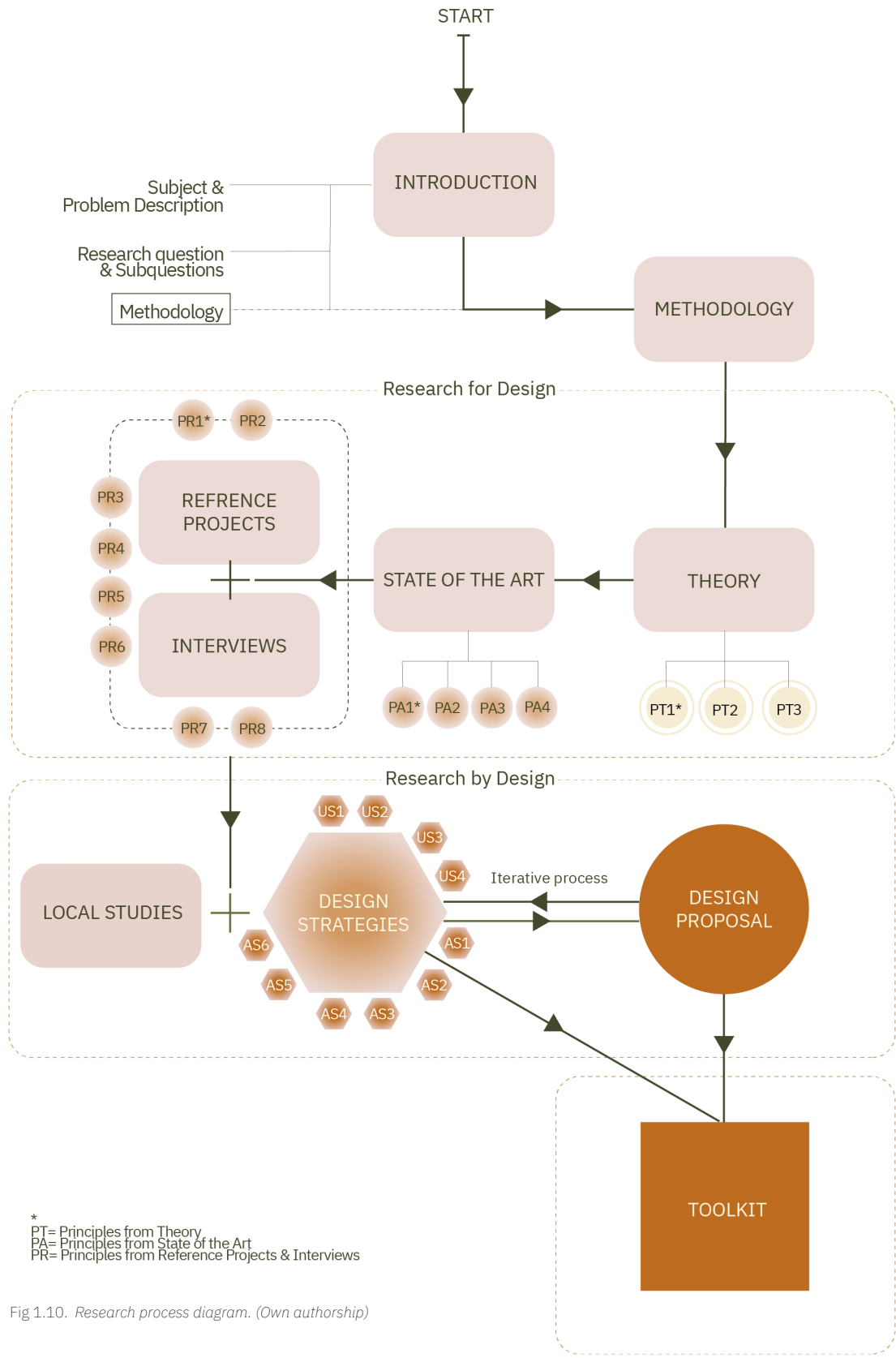
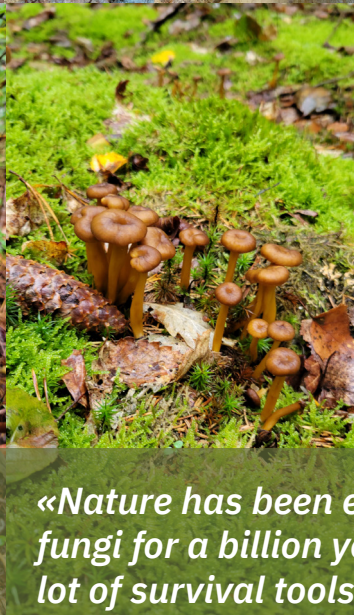

Fig 1.10. Research process diagram. (Own authorship)



In this section, we explain the theories we draw on in our research, explore the state of the art around mycelium, propose a classification for Urban Mycelium Farms, their spatial requirements, and design strategies.



«Nature has been experimenting with fungi for a billion years, perfecting a lot of survival tools. We can use these tools in fantastic ways - to revive damaged ecosystems, to help offset global warming, and even to prevent diseases.»

-Paul Stamets



2.1 Theoretical framework

Theories

The approach of this thesis is guided by 3 main theories: Biophilic design, Social-ecological urbanism, and the Co-produced city.

Biophilic Design

In the biophilic design theory developed by R. Kellert and J. Heerwagen called “Biophilic Design: The Theory, Science, and Practice of Bringing Buildings to Life”, the interactions happening between human nature, the built environment, and the natural environment, emphasize a shift of paradigm where anthropocentric reasoning is not the main motor of development, instead it integrates into a broader network of social and biological interactions that must be in balance to create healthier environments for all the species including us. (Kellert, S. R., & Heerwagen, J. H. 2008)

Kellert divides the biophilic design theory into 2 dimensions, which then he subdivides into 6 elements with specific traits each one of them. In our case, we are mainly focusing on concepts that work with aspects of urbanism and social fabric, working with Place-based relationships and taking other

attributes from the other elements. We picked this approach because the core values of our thesis depart from a reconnection between the human-built environment and the natural environment, having the social fabric as the main base for this reconnection to happen.

In Place-based relationship elements, we want to emphasize that for urban mycelium farms to exist, these must have a strong link with the location, context, and social dynamics already existing in the area. We also bring in some other characteristics from Evolved Human-Nature Relationships and Environmental Features that impact how the social activities and design of the space have to be accomplished, from an outlook perspective fall into the broader scope of Place-based relationships (Fig. 2.1).

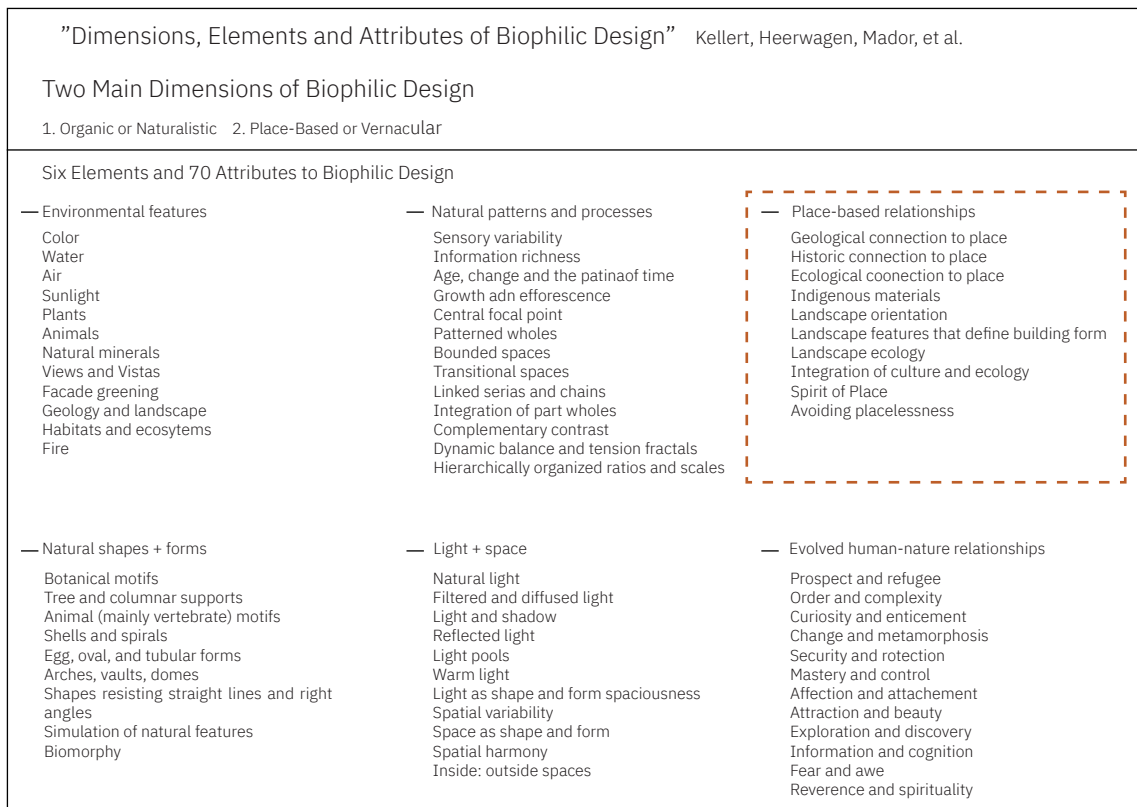

Fig 2.1. Biophilic design principles. (R. Kellert & Heerwagen, Biophilic Design)

2.1 Theoretical framework

Theories

Social-Ecological Urbanism

The theory of Social-Ecological urbanism lies in the connection of social systems, ecological systems, and adaptive management; encompassing ecological resilience, local and traditional systems, with environmental management. (Berkes & Folke 1998).

This approach for planning cities and urban density agglomerations seeks to compile designs for mitigation of carbon emissions, and adaptation measures to enhance adaptive capacities by integrating ecosystems and their services in planning and urban design. It works with the resilience of both social and ecological systems, and adaptability to shocks by reorganizing, utilizing, and developing without losing fundamental functions. (Barthel et al., 2013)

In this sense, social-ecological urbanism comes as a tool to design better urban spaces and cities that not only focus on the human-built environment interactions but also take into consideration the active and relevant role other species play in the bigger scenario of our cities. This effort to bring biotopes, ecosystems, their services, and other species we share space with and their interconnections onto the table of planners and architects is an example of how we can create more sustainable spaces and cities.

But, how does taking into account bees' pollination patterns (T. Häll A., 2023) or the night movement of some species (Lindroth M. & Svensson M., 2022) contribute to a better city? It all scales down to urban resilience and our capacity to counter the effects of climate change and the scaling extinction of species (Barthel et al., 2013), which consequently links to our well-being and survival.

Countless species coexist with us in cities, and we can visually spot them either a bee, a magpie, a duck, or a rat, but some other less-seen species create intricate and complex relationships around us that we are not even aware of, which give life to many of our green spaces in cities and major ecosystems. Only by looking down while walking, we can find examples of it next to the sidewalk. That is where we find fungi, and where mycelium farms take their foundation from, drawing on their role as decomposers and key elements in nutrient cycling (Horlick, 2023).

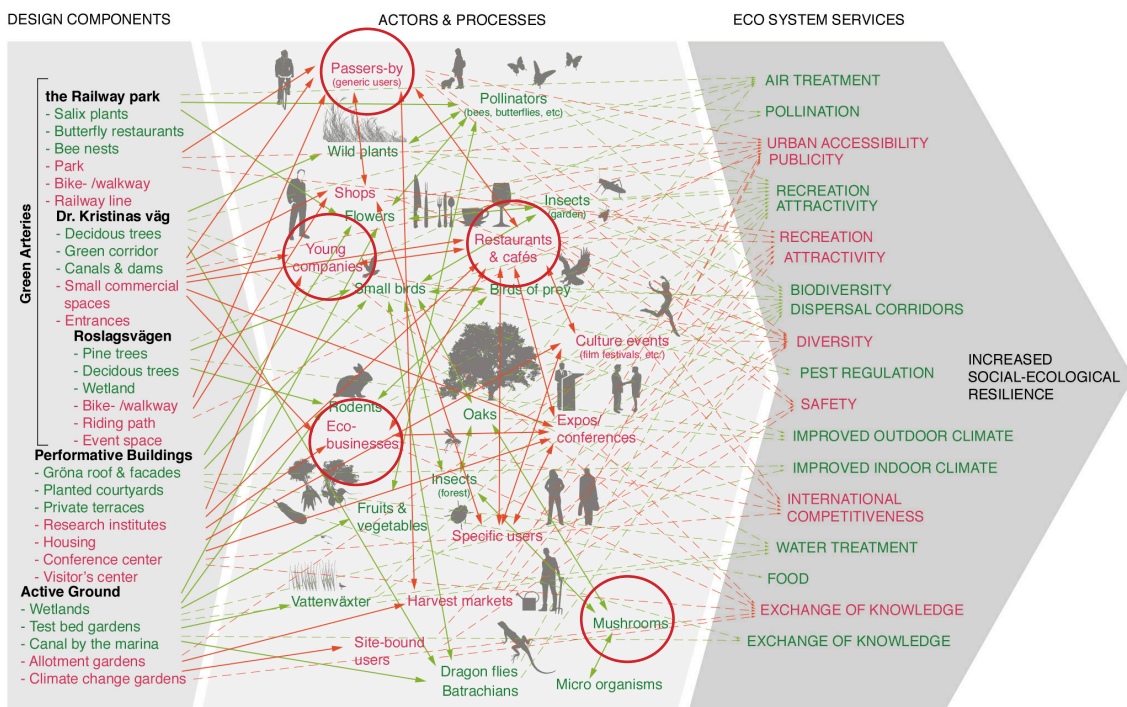

Fig 2.2. Diagram showing elements and dynamics involved in social-ecological processes. (Ernstson, H., 2013)

2.1 Theoretical framework

Theories

The Co-produced city

Co-produced city refers to a concept in urban planning and governance where multiple stakeholders, human as well as non-human, actively participate in the design, development, and management of the cities alongside government authorities and other institutions. Co-production processes within urban areas can be a key factor in increasing cities' resilience.

The term 'co-production' was originally defined in the late 1970s by political economist Elinor Ostrom as 'the process through which inputs used to produce a good or service are contributed by individuals who are not "in" the same organization' (Ostrom, 1996, p. 1073). Ostrom related co-production with resilience and commons, stressing the importance of collective governance in holding these aspects together (Ostrom, 1990).

Why addressing resilience is important in cities?

Due to current environmental and economic turmoil, our cities need to become more resilient and need to organize in order to adjust and thrive in rapidly changing circumstances (Petcou & Petrescu, 2015). This imperative for resilience, currently lacking in many cities would require an ambitious co-production effort involving the entire urban populace. New approaches to urban regeneration are desperately needed and could benefit from the increased social capital attending to the diminishment of financial capital (Petcou & Petrescu, 2015).



Fig 2.3. Community gardens at Agrocité—an agro-cultural unit within the R-Urban network in Colombes, June 2013. (Atelier d'architecture autogérée, n.d.)

2.2 State Of The Art: Mycelium, Urban Mycelium Farms and its components

Mycelium and its role in ecosystems

Mycelium and its role in ecosystems

The inspiration for this thesis spawns from fungi and the role they play in ecosystems, to this end, the concept of what a mushroom is of common knowledge, however, the anatomy of it and what our specific research draws upon mycelium, is still quite elusive to many people's minds.

Mushroom and mycelium are both parts of the same organism called fungus: while the fruiting body (commonly called mushroom) in some species is responsible for reproduction, the mycelium is the cellular network responsible for its nourishment. (Fig.2.4). A cobweb-like fabric that links nutrient sources to the fungus and even more species in between, transforming and recycling large organic molecules into simpler forms that feed the fungus and other organisms in the ecosystem. In other words, fungi work as an interface organism between life and death in all environments. (Stamets, P., 2005).

Some fungi develop as a single organism, displaying a fruiting body and an underground mycelial structure, but other species live in symbiotic relationships with the majority of plants in their surroundings, entirely underground with no fruiting bodies and only a mycelial body (Karas, S., n.d.)(Fig.2.5). This type of fungi is called mycorrhizal fungi, myco meaning fungi and rhyza meaning root. Its symbiotic bond nurtures different species of plants and the fungi itself, endowing them with the capability of withstanding droughts by extending its absorption reach and enabling them to communicate with other species that are not related (Popkin, 2019)(Fig.2.6).

Many well-known mushrooms like chantarell, matsutake, or truffles belong to this category of fungi. This mutualistic relationship between fungi and plants can increase the amount of nutrients a plant's roots can absorb anywhere from 10 to 1000 times while also protecting it from certain diseases (Karas, S. n.d.). In return, the plant shares sugars produced by photosynthesis to the fungus.

In cold weather and winter seasons, sunlight periods decrease meaning a lack of photosynthesis in plants, this reduces its capability to produce sugars, thus hindering the growth of new blooms, leaves, and root mass. In this scenario, mycorrhizal fungi can leverage this decrease in photosynthesis by delivering carbohydrates and sugars to the plant.

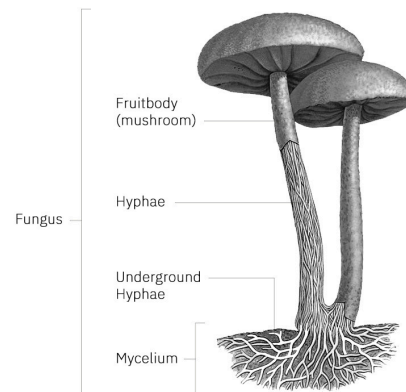

Fig 2.4. Anatomy of fungus. (Ward, 2016)



Fig 2.5. Picture showing the root system of a plant in symbiosis with a mycorrhizal fungus. (Karas, n.d.)

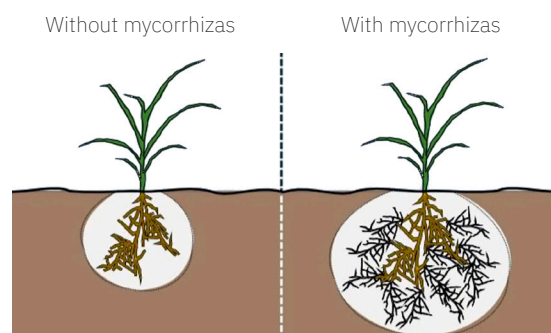

Fig 2.6. A plant colonized by mycorrhizal fungi reaches more soil to access more nutrients and water, compared to non-colonized plants. (Cobb, 2020)

2.2 State Of The Art: Mycelium, Urban Mycelium Farms and its components

Mushroom and mycelium in relation with humans

Over many years, mycorrhizal fungi can grow into a mycelial interconnected network, once formed this network can benefit all the connected species by exchanging nutrients and water across the entire system (Fricker, M., 2017)(Fig.2.7). Mycelium networks create communication among different organisms and build ideal conditions for nourishment in soils.

As it grows, mycelial networks build and expand grids of tunnels and micropores that hold oxygen in them, allowing water to percolate into the soil. In consequence, the amount of microbes increases meaning a higher nutrient bio-availability for all the organisms, creating rich soils for biodiversity and ecosystems.

Mushroom and mycelium in relation with humans

There is evidence that indicates humans were already consuming mushrooms as far as 19,000 years ago, being diet the first contact humans had with fungi, using them as a food source (SINC, 2015). Later on, the first signs of humans harnessing the power of fungi date back to 10,000 years ago, using yeast and fermentation to produce bread and beer.

On the other hand, the cultivation of mushrooms is more recent. The first examples of mushroom agriculture appeared in Japan and China with shitake log growing techniques 1800 years ago(Fig.2.8). Later on in Paris, France, around 1700, mushroom caves were used to cultivate white agaric button mushrooms with compost, horse manure, and straw(Fig.2.10). Empty limestone quarries underneath the city functioned as spaces for processing these materials and gave place to the beginning of the large-scale mushroom industry, to eventually spread to England and America. From then on, the mushroom production system kept on improving and scaling up to turn into what we nowadays know as profit-driven mushroom farms all over the world (GrowCycle, 2015)(Fig.2.9).

As seen, cultivation techniques primarily focus on the production of mushrooms for consumption, but rarely on other uses including mycelium. Once mycelium builds its network, we can control its growing conditions to build predictable structures that we can apply to many uses.

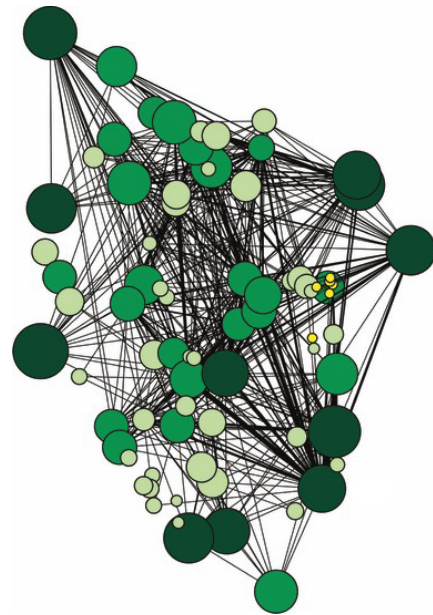

Fig. 2.7 A diagram of a fungal network that links a group of trees, showing the presence of highly connected older or "mother trees" in dark green, while younger trees are in paler green (Beiler et al., 2010).



Fig 2.8. Shitake log technique in Japan. (Sugimoto, 2021)



Fig 2.9. Industrial mushroom production facility. (Farmer, 2021)



Fig 2.10. Underground mushroom cultivation caves in Paris, France. (GroCycle, 2015)

2.2 State Of The Art: Mycelium, Urban Mycelium Farms and its components

The roles of an Urban Mycelium farm in supporting social and ecological processes

The roles of an Urban Mycelium farm in supporting social and ecological processes

There are a myriad of possibilities for mycelium products in our daily lives. Departing from food to building materials, clothing, packaging, biomedicine, or biofuels, among others. As a result, this leads to the variety of functions a mycelium farm can have. In Fig.2.11, we categorized the role of mycelium farms into five groups; Environment, Economy, Health, Society, and Space. Under each category, some examples of these roles are listed. There is a possibility that one mycelium farm belongs to multiple categories based on its goals. For instance:

A mycelium farm can have its focus on plastic management, as the biotechnological characteristics of mycelium can help us replace the increasing plastic accumulation in the environment and diminish our plastic consumption (Bayer, E. 2019), this means it can belong to the Environment, but if it also has the goal to profit from producing and selling plastic alternatives, then it fits also in the category Economy.

The most known function of a mycelium farm is to produce food (Economy and Environment). Mycelium offers an ethical alternative for producing meat-like substances, with far less harm to the environment compared to raising livestock conventionally. This approach reduces greenhouse gas emissions, minimizes the need for food crops as animal feed, and limits land use change. Additionally, the process of cultivating mycelium generates minimal waste, mostly compostable, and demands only a small amount of energy. (Bayer, E. 2019). Furthermore, the resources needed to cultivate fungi can be waste products from other services and industries, contributing to the culture of urban symbiosis and circularity.

As observed in the diagram, the possibilities fungi and mycelium present are numerous, ranging from health to environmental, food, or even construction. We as humans have just started to discover some of the great potentials mycelium has and how these potentials can be seized to our advantage to change our path of development into a bio-based one, while also reshaping the way we relate to nature.

Today, we as architects and planners must begin to think of how to harness and be inspired by the potential fungi and mycelium offer. Being aware of the challenges we face related to climate change or social inequalities, we can design solutions and strategies to these problems by properly studying and using these organisms. Endeavors to merge the world of mycelium and architecture already exist, showing us that this combination is possible giving place to a myriad of application and research fields.

Bridging natural
and urban enviro
27-37

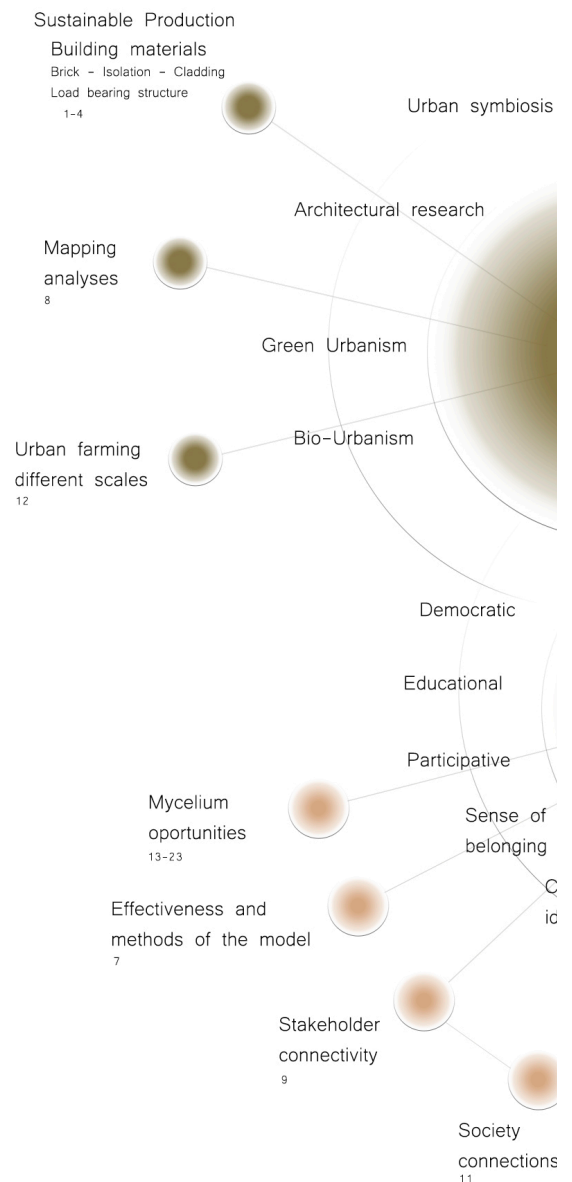

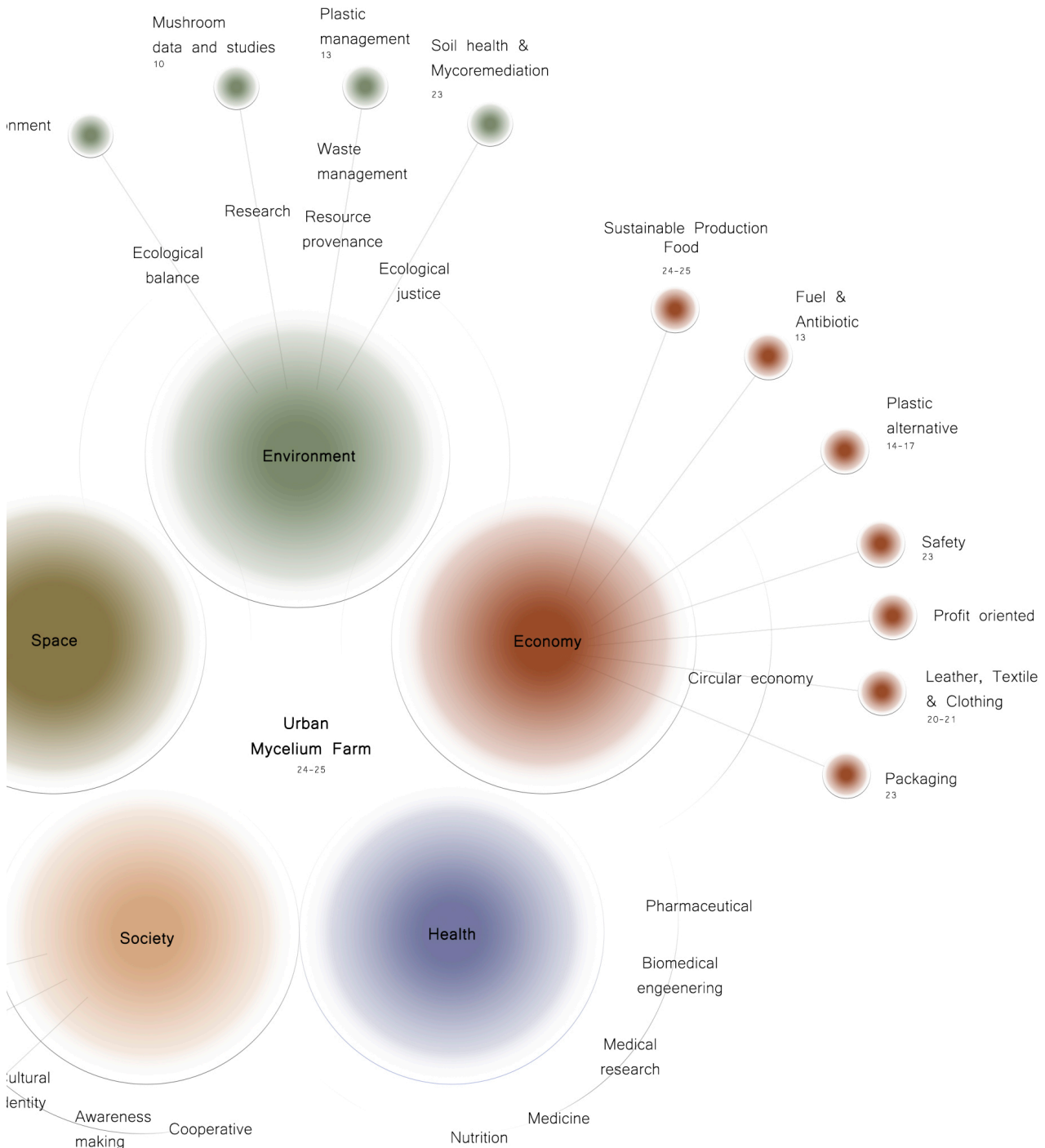

Fig 2.11. Diagram of possibilities a Urban Mycelium Farm can open. (Own authorship)

2.2 State Of The Art: Mycelium, Urban Mycelium Farms and its components

Types of Urban Mycelium Farms

Types of Urban Mycelium Farms

In accordance with the previous diagram Fig.2.11, each role has main types of mycelium farms that can exist (Fig. 2.12) and local species of fungi that serve each type (Fig.2.13). Understanding these types is essential to later connect them with their spatial requirements.

SPACE

- **Sustainable production** – The focus is production of sustainable products. Food is the most common one, however, building materials such as cladding panels, construction bricks, or loadbearing structures also belong to this category. (Jaquet, 2014)

Local species: Scaly tooth, Oyster, Artist's bracket, Tawny grisette, Amethyst deceiver, Yellow russula, Shaggy ink cap, Golden chanterelle and Penny bun. (Fig.2.13)

SOCIETY

- **Educational** – Farms in this category have a close connection to schools at all levels. They actively involve children and youth through workshops and daily activities, seeking to build stronger relations between younger generations and the natural environment. (Gabriel, S., 2024)

Local species: All species. (Fig.2.13)

- **Awareness** – Spreading knowledge and making an impact on the community through bio-based strategies is the main objective. Communication and awareness campaigns are relevant activities.

Local species: All species. (Fig.2.13)

- **Identity** – The focus is to promote mycelium farming through local fungi species. These farms will collaborate with local colony organizations, seasonal events, and markets to build a strong sense of appropriation and local identity. (Kellert & Heerwagen, 2008, p.292)

Local species: All species. (Fig.2.13)

HEALTH

- **Medicine** – The focus is to produce medications and health-related products from fungi. Antibiotics, anti-inflammatory, anti-carcinogenic, anti-bacterial medicine, and biomedical elements fall in this category. (Antinori, et al., 2021)

Local species: Sniff tick, Artist's bracket, Tawny grisette, Yellow russula, Shaggy ink cap, Penny bun. (Fig.2.13)

ECONOMY

- **Profit** – The focus is to increase economic gains through sales and distribution of products (Surtees, J., 2023). It includes linkage with startups, creating new job opportunities, and fostering new links with restaurants and companies.

Local species: All species. (Fig.2.13)

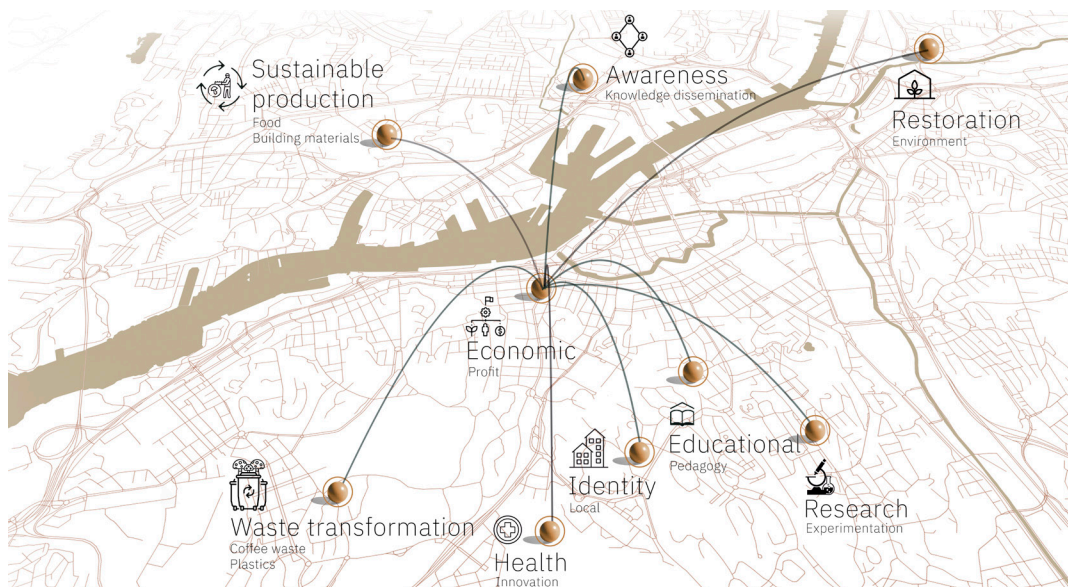

Fig 2.12. Main types of Urban Mycelium Farms. (Own authorship)

2.2 State Of The Art: Mycelium, Urban Mycelium Farms and its components

Types of Urban Mycelium Farms

ENVIRONMENT

- Restoration – The focus is to restore soils and water bodies through mycoremediation strategies. It includes both in-situ and ex-situ tactics and covers heavy metals, organic pollutants, arsenic, pesticides, and oil spills. (Darwish, L., 2022)

Local species: Oyster, Genus aspergillus, Amethyst deceiver, Shaggy ink cap and Genus trichoderma.

- Waste transformation – The objective is to decompose waste resources that can not be recycled, are difficult to process, or require long times to naturally degrade. This includes PET, HDPE, PVC, PP, PS, and other types of plastics. (Crew, B., 2016)

Local species: Oyster, Genus trichoderma. (Fig.2.13)

- Research – The main objective is to investigate new opportunities with fungi and fungi-based products. Innovative building materials, plastic alternatives, new medicines, or biomedic products fall into this category. (Nair, R. 2018)

Local species: All species. (Fig.2.13)

These are the main types of Urban Mycelium Farms we explored based on the capabilities fungi and mycelium offer. The next step is to understand the stakeholders involved and the spatial requirements each farm needs to function according to its role.













 <p>Scaly tooth (<i>Sarcodon squamosus</i>)</p>	<ul style="list-style-type: none"> - Edible - Bonds with pines, spruces and firs <p>Uses</p> <ul style="list-style-type: none"> - Pigments and dyes - Highly nutritious 	 <p>Tawny grisette (<i>Amanita fulva</i>)</p>	<ul style="list-style-type: none"> - Edible - Bonds with birch, oak, spruce, pine, chestnut and alder <p>Uses</p> <ul style="list-style-type: none"> - Medical anti carcinogenic, antibacterial
 <p>Sniff tick (<i>Formes fomentarius</i>)</p>	<ul style="list-style-type: none"> - Non edible - Habitats for smaller organisms (insects) - Parasites birch, beech, oak and maple <p>Uses</p> <ul style="list-style-type: none"> - Combustible - Clothing & leather - Plastic substitute - Medical anti-inflammatory, anti-microbial 	 <p>Amethyst deceiver (<i>Laccaria amethystina</i>)</p>	<ul style="list-style-type: none"> - Edible - Bonds with beech and oak <p>Uses</p> <ul style="list-style-type: none"> - Mycoremediation Arsenic (bioaccumulation)
 <p>Oyster mushroom (<i>Pleurotus ostreatus</i>)</p>	<ul style="list-style-type: none"> - Edible - Habitats for smaller organisms - Parasites birch, beech, oak and maple <p>Uses</p> <ul style="list-style-type: none"> - Building material bricks - Furniture - Leather - Mycoremediation Heavy metals & organic pollutants 	 <p>Yellow russula (<i>Russula claroflava</i>)</p>	<ul style="list-style-type: none"> - Edible - Bonds with birch and aspen <p>Uses</p> <ul style="list-style-type: none"> - Medical anti-inflammatory, immunomodulatory
 <p>Artist's bracket (<i>Ganoderma applanatum</i>)</p>	<ul style="list-style-type: none"> - Edible - Creates habitats for smaller organisms - Parasites beech and poplar <p>Uses</p> <ul style="list-style-type: none"> - Medical anti carcinogenic, phytopathological - Firemaking - Leather like - Art and drawings 	 <p>Shaggy ink cap (<i>Coprinus comatus</i>)</p>	<ul style="list-style-type: none"> - Edible - Habits in hemp, compost & enclosed environments <p>Uses</p> <ul style="list-style-type: none"> - Mycoremediation Heavy metals (lead) - Medical anti carcinogenic, hepatoprotective
 <p>Bleeding Hydnellum (<i>Hydnellum caeruleum</i>)</p>	<ul style="list-style-type: none"> - Non edible - Bonds with oaks <p>Uses</p> <ul style="list-style-type: none"> - Dyes and pigments 	 <p>Penny bun (<i>Boletus edulis</i>)</p>	<ul style="list-style-type: none"> - Edible, highly nutritious - Bonds with pine, spruce, beech and hemlock <p>Uses</p> <ul style="list-style-type: none"> - Extensively used in cuisine - Medical anti carcinogenic, anti viral & anti bacterial
 <p>Genus Aspergillus (<i>Aspergillus niger</i>)</p>	<ul style="list-style-type: none"> - Microfungi - Habits in hemp, compost and enclosed environments <p>Uses</p> <ul style="list-style-type: none"> - Mycoremediation Heavy metals and pesticides - Fermentation processes - Biotechnology - Food industry 	 <p>Genus Trichoderma (<i>Trichoderma harzianum</i>)</p>	<ul style="list-style-type: none"> - Microfungi - Habits in may types of soils <p>Uses</p> <ul style="list-style-type: none"> - Mycoremediation Heavy metals & pesticides - Soil fungicide - Biotechnology - Agriculture

Fig 2.13. Gothenburg fungi local species, traits and uses.

(Representation: Own authorship) Data: Swedish University of Agricultural Sciences. Artdatabanken.

2.2 State Of The Art: Mycelium, Urban Mycelium Farms and its components

Stakeholder composition

Urban Mycelium Farms: Stakeholder Composition for Implementation

An Urban Mycelium Farm requires contribution from an array of stakeholders with diverse perspectives. Although all co-produced Urban Mycelium Farms benefit from the following resource flow diagram shown in Fig. 2.14, the composition and involvement of stakeholders can vary depending on the scale of the Mycelium Farm, its location, specific goals (e.g., food production, material innovation, environmental remediation), and the unique needs and priorities of the community. Below is an overview of the key stakeholders and their roles, divided into top-down and bottom-up stakeholders:

A. Top-down

1- Local Government and Regulatory Bodies: Local government can support the initiative

- Through funding, incentives, developing capacity for policy support, and empowerment.
- City planners, urban developers, and architects translate regulatory requirements into spaces.

2- Private Sector Partners:

Landowners provide land or space for Mycelium farms

3- Academic and Research Institutions:

Research institutes contribute with scientific knowledge, research funding, and expertise

4- Utilities and Infrastructure Providers:

Energy providers, waste management companies, and water provide infrastructure support.

B. Bottom-Up

1- Community Organizations and NGOs:

Neighborhood groups, local collectives, and community organizations facilitate community engagement and participation using their network and expertise.

2- Residents and Community Members:

Engagement of residents fosters community ownership and support for the urban mycelium farm. They can contribute labor, expertise, and financial support to various aspects of farm functions.

3- Bio-based Startups

Bio-based startups contribute through investment and collaboration.

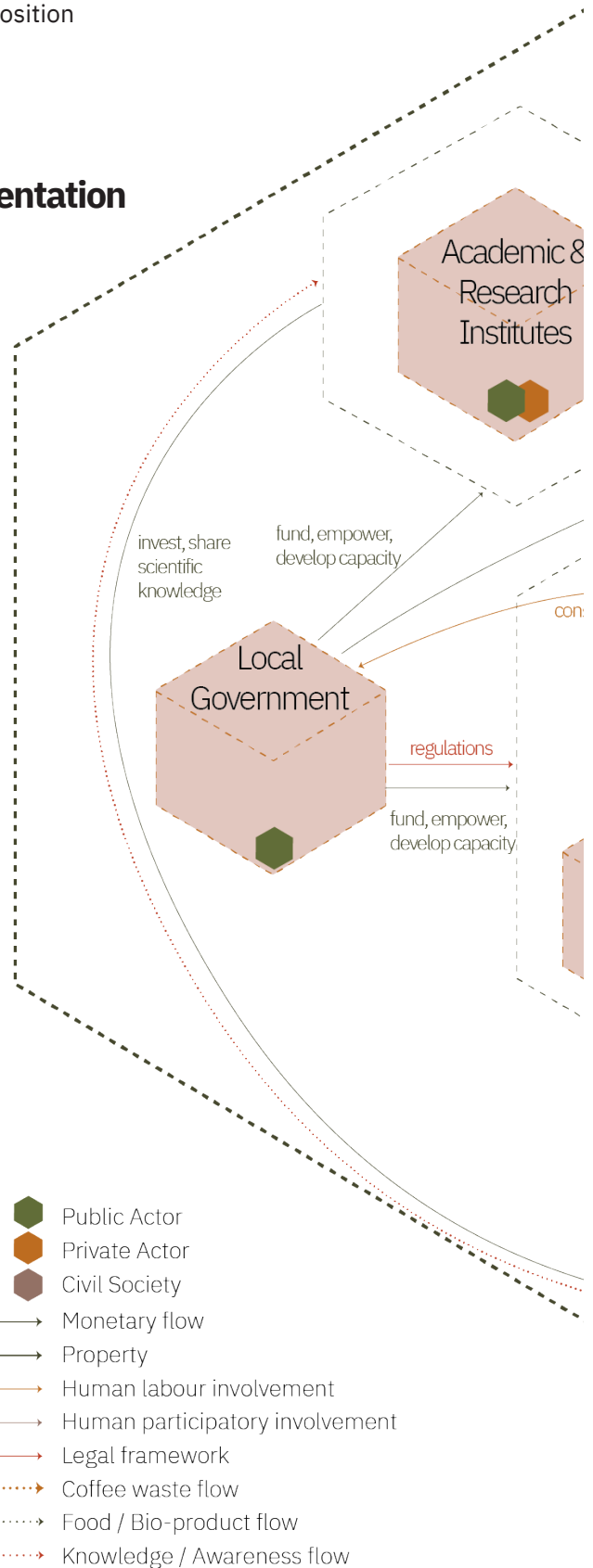
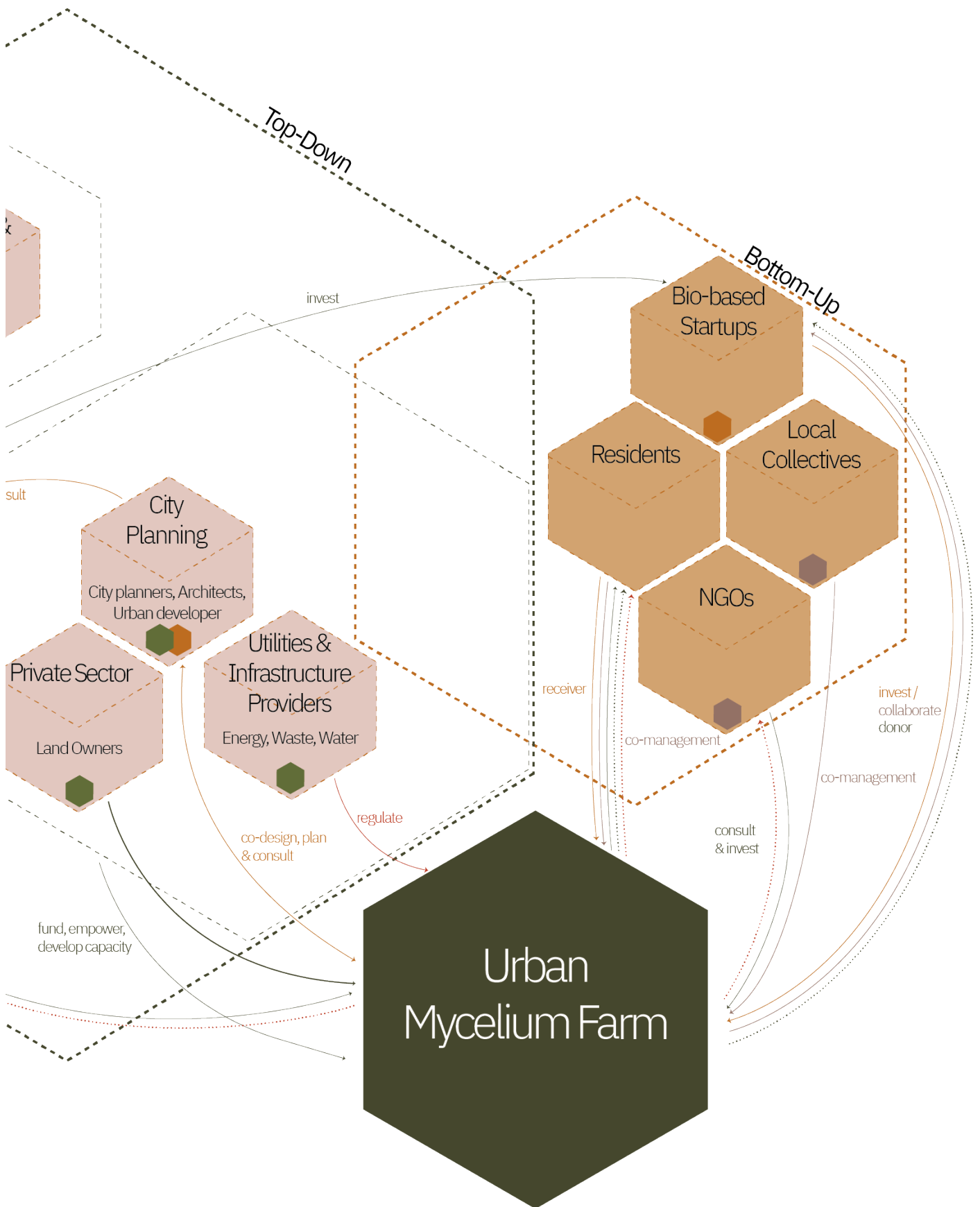

Fig 2.14. General stakeholder composition for all Urban Mycelium Farms. (Own authorship)



2.3 Spatial Requirements

Generic spatial requirements

Spatial requirements of Urban Mycelium Farms

Developing an Urban Mycelium Farm is tied to spatial requirements for its realization. These requirements arise from the Research for Design process, with principles collected from Theory, State of the art, and Reference projects together with Local studies (Fig.2.15).

We divide them into two categories: generic spatial requirements and specific spatial requirements. Furthermore, we divide generic and specific spatial requirements into two subcategories: urban and architectural (Fig. 2.16). While generic requirements apply to all types of farms, specific ones belong to each particular type of farm.

Each requirement is informed by multiple principles, that when compiled give shape to the design strategies and the process of design we will follow (Fig.2.17).

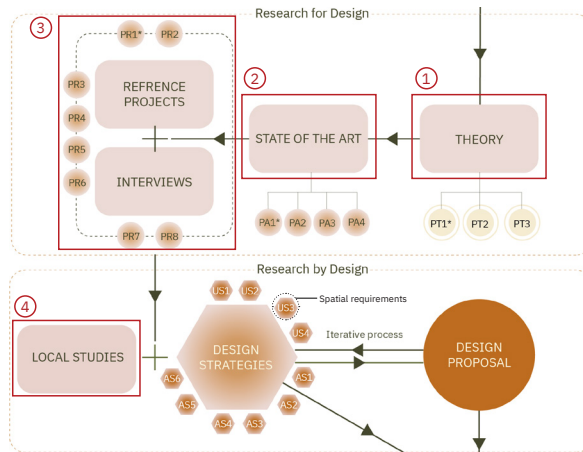

Fig 2.15. Diagram of steps to reach the spatial requirements and design strategies . (Own authorship)

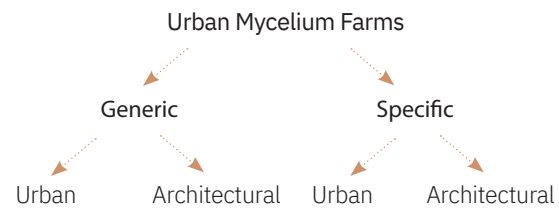

Fig 2.16. Spatial requirements concept structure for Urban Mycelium Farms (Own authorship)

THEORETICAL PRINCIPLES	CONCEPTUAL PRINCIPLES	REFERENTIAL PRINCIPLES	SPATIAL REQUIREMENTS	informed by
			URBAN SCALE	
		<ul style="list-style-type: none"> PR1: Coffee waste & spent mushroom substrate (SMS) as fluxes in the material flow PR2: Creating a new model of agriculture & production PR3: Local production in urban voids PR4: Community & collaborative resilient neighborhood scale to integrate community 	<ul style="list-style-type: none"> US1: 1km to 2km reach to input and output resource sources US2: 500m proximity to residential areas US3: Access to cycling infrastructure US4: High centrality 	<ul style="list-style-type: none"> PT3, PA2, PR1 PA2, PR6 PT2, PA3, PR1, PR5 PT2, PA3
<ul style="list-style-type: none"> PT1: Biophilic Design PT2: Social-Ecological Urbanism PT3: The Co-produced city 	<ul style="list-style-type: none"> PA1: Urban voids / Public spaces PA2: Urban symbiosis PA3: Network analysis PA4: Mushroom and mycelium physical needs 	<ul style="list-style-type: none"> PR5: Linkage to other agriculture types PR6: Promote waste awareness PR7: New policies & legislation PR8: New employment opportunity PR9: Green transportation 	ARCHITECTURAL SCALE	
			<ul style="list-style-type: none"> AS1: Conditions for mycelium & mushroom growing AS2: Public accessible sheltered space AS3: Bio-based and sustainable constructive system AS4: Community space for participatory engagement AS5: Learning facilities AS6: Research & prototyping facilities 	<ul style="list-style-type: none"> PA1, PA4, PR3 PT1, PT2, PT3, PA3, PA5, PR2, PR4 PT1, PA2, PR2 PT2, PA3, PR2, PR3, PR5, PR6, PR9 PT3, PR2, PR4, PR6 PT3, PA2, PA4, PR2

Fig 2.17. Spatial requirements chart. (Own authorship)

2.3 Spatial Requirements

Generic spatial requirements

Generic spatial requirements

Generic spatial requirements correspond to those that will be the same in all farms regardless of their context, both on an urban scale and an architectural scale.

Urban Generic Spatial Requirements (US#)

We envision Mycelium Farms to function in urban clusters that are in close distance of stakeholders, sources, and infrastructure. Strengthening local economy and promoting independence from fossil energy sources. Based on this, we set 4 generic requirements at an urban scale that correspond to all types of farms:

US1

- 1km to 2km reach to input and output resource sources – Work at a local scale with zero carbon footprint from transportation, hence the need to be proximate to donors of organic waste and receivers of the products.

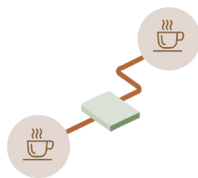

US3

-**Access to cycling infrastructure** – Input and output resources are transported by bicycle, thus the need for this type of infrastructure.

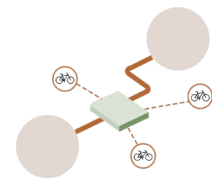

US2

-500m proximity to residential areas – Stakeholders involved in the running, administration, and organization of the farm should/must live close to the farm.

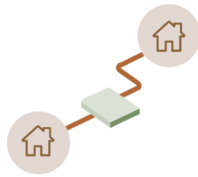

US4

-**High centrality (Space syntax)** – High rates of centrality will cater mycelium farms with accessibility, greater interaction with people, and strategic location for maximum effect. It is measured through angular betweenness and integration.

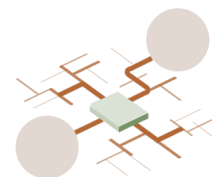

Architectural Generic Spatial Requirements (AS#)

Most indoor spaces can be suitable for growing mycelium and mushrooms (Grocycle, 2020). The only architectural generic spatial requirements are to dedicate space for all three main stages of mushroom growth, space for services, and a bio-based approach while building the spaces.

AS1

- **Conditions for mycelium and mushroom farming** – Prioritize the use of urban voids (unused or underused sheltered spaces). Dedicate spaces for each one of the stages needed for growing. From substrate to final product:

- **Stage 1: Mixing & Inoculation** – This is where the substrate ingredients and mushroom spawn are mixed and bagged.

(Sustainable food production type farms can be dedicated solely to producing inoculated substrate, to later be distributed to other food production type farms for incubation and fruiting. This divides the process of growing in two, making it simpler and easier, more specialized (Kernser Edelpilze, 2009)).

- **Stage 2: Incubation** – The grown bags are left in a warm, dark space for the spawn to grow throughout the bag.

- **Stage 3: Fruiting** – The colonized bag is exposed to fresh air, humidity, and minor light, causing the mycelium to 'fruit.'

- **Services** – These spaces are dedicated to:

- 1.-Store input and output resources or material.
- 2.-Changing rooms for people working on the farm.
- 3.-Cleaning facilities.
- 4.-Spaces for workers' needs regarding food, storage, and cleaning.

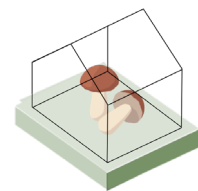

AS3

- **Bio-based constructive system** – Prioritize the use of bio-based materials like mycelium, wood, and other indigenous materials.

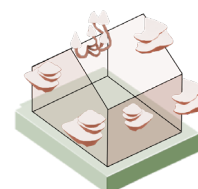

2.3 Spatial Requirements

Specific spatial requirements

Specific spatial requirements

Specific spatial requirements correspond to each particular type of farm and we divide them into **urban** and **architectural**. The existing types of farms are as follows: Awareness, Educational, Profit, Identity, Research, Medicine, Restoration and Waste transformation.

	Urban	Architectural
AWARENESS	<ul style="list-style-type: none"> - High flow of passers-by – Needed to reach the highest amount of people. - Proximity to public gathering spaces – This will contribute to reach more people and merge uses of public spaces. 	<ul style="list-style-type: none"> - Creating visible connections between public street & interior of the building – This will incentivate locals and passers-by to visit and take part of the farm
EDUCATIONAL	<ul style="list-style-type: none"> - Proximity to schools – To incorporate childhood and youth by providing them a hub of environmental education, leisure and joy. 	<ul style="list-style-type: none"> - Space for gathering: showcasing & learning – This space will promote activities and workshops with children and youth to explore fungi and its possibilities. - Space for innovation: Innovation lab – Experiments and prototyping from a young age will stimulate creativity, ingenuity and cooperative work.
PROFIT	<ul style="list-style-type: none"> - High proximity to markets, restaurants, shops & single costumers – To increase number of sales and reduce costs of transportation - Proximity to high population density areas – To increase number of costumers and people who can contribute to the farm. 	<ul style="list-style-type: none"> - Startup incubator – It will offer support and guidance to turn ideas related to mycelium and fungi into succesfull business ventures.
IDENTITY	<ul style="list-style-type: none"> - Proximity to colony organizations – Seeking to integrate already existing local farming practices with mycelium farming and fungi cultivation (Slotsskogskolonien, 2023). - Proximity to community culture places (e.g., folkethus) – To incorporate fungi as an element of indigenous biodiversity and colective culture. 	<ul style="list-style-type: none"> - Space for gathering: meetings & organization – To create stronger communities and participatory practices. - Space for showing relationship between fungi and local culture – To highlight the importance of fungi in local history and culture through cuisine, arts and crafts, traditions and celebrations.
RESEARCH	<ul style="list-style-type: none"> - Proximity to universities, laboratories & research centers – Allowing to work in close collaboration with institutions and ongoing research projects. 	<ul style="list-style-type: none"> - Space for innovation: Innovation laboratory – It will be a support space for research in close collaboration with ongoing projects about mycelium and fungi.
MEDICINE	<ul style="list-style-type: none"> - Proximity to healthcare institutions & facilities – Allowing to work in close collaboration with healthcare institutions, ongoing research projects and medicine production. 	<ul style="list-style-type: none"> - Space for innovation: Innovation laboratory – It will be a support space for research in close collaboration with institutions about mycelium and fungi.

2.3 Spatial Requirements

Specific spatial requirements

	Urban	Architectural
SUSTAINABLE PRODUCTION	<p>FOOD</p> <ul style="list-style-type: none"> - High proximity to restaurants, cafes & offices – Needed to have a high availability of resources to cultivate. - High proximity to restaurants, cafes, markets, and major markets – Needed to reach as many customers as possible in a close distance. 	<ul style="list-style-type: none"> - Space for product storage – To keep and store fresh products for a longer time. - Bigger space for fruiting – To maximize the amount of food obtained
RESTORATION	<p>MATERIALS</p> <ul style="list-style-type: none"> - Proximity to constructive material companies and distributors – To open gaps in the market for bio-based construction materials. <ul style="list-style-type: none"> - Located on polluted land or water bodies – To implement mycoremediation and heal soils or water bodies from hazardous elements. - Proximity to public gathering spaces – To prioritize the health of the population and create awareness around mycoremediation. 	<ul style="list-style-type: none"> - Space for construction of prototypes – To experiment and delve into new building materials and prototypes. - Space for laboratory testing – It will help to run analysis on soil and water health tracking mycoremediation effects.
WASTE TRANSFORMATION	<ul style="list-style-type: none"> - Proximity to clusters of high coffee consumption – To have a high amount of resources to transform with minor transportation costs. - Proximity to waste management facilities – This will incentivize new ways to incorporate fungi in waste management processes, decomposing non-renewable waste and other compounds. 	<ul style="list-style-type: none"> - Space for degradation and transformation of waste material – It will help to transform the waste into new materials and apply different methods.

The previous specific requirements delimit the implementation of each type of Urban Mycelium Farm, focusing on their main objectives and elements to highlight.

2.4 Design Strategies

Design strategies

To strengthen the objective of each type of farm, we developed design strategies for each type (DS#):

AWARENESS		EDUCATION	
<ul style="list-style-type: none"> - DS1.1 - Facilitate interaction between the farm and passers-by - 	<ul style="list-style-type: none"> - DS1.2 - Extend the farm to other public spaces - 	<ul style="list-style-type: none"> - DS2.1 - Incentivize childhood and youth to be involved in environmental knowledge, resource provenance and fungi- 	<ul style="list-style-type: none"> - DS2.2 - Create spaces that can have multiple uses and modular elements -
PROFIT		IDENTITY	
<ul style="list-style-type: none"> - DS3.1 - Upscale food production and diversity of products - 	<ul style="list-style-type: none"> - DS3.2 - Incentivize connections with companies and a growing network of customers- 	<ul style="list-style-type: none"> - DS4.1 - Foster a sense of belonging through local biodiversity - 	
RESEARCH		MEDICINE	
<ul style="list-style-type: none"> - DS5.1 - Foster new ways of prototyping with mycelium - 		<ul style="list-style-type: none"> - DS6.1 - Create connections between the farm and local healthcare institutions- 	<ul style="list-style-type: none"> - DS6.2 - Develop deep understanding of local species and their impacts on health -
SUSTAINABLE PRODUCTION		RESTO-	
<ul style="list-style-type: none"> - DS7.1 - Upscale food production and diversity of products - 		<ul style="list-style-type: none"> - DS8.1 - Bring people closer and expand their knowledge about mycoremediation processes - 	<ul style="list-style-type: none"> - DS8.2 - Develop a deep understanding of local species and their impacts through mycoremediation -
WASTE TRANSFORMATION		PUBLIC	
<ul style="list-style-type: none"> - DS9.1 - Bring people closer and expand their knowledge about resource provenance and fungi- 	<ul style="list-style-type: none"> - DS9.2 - Develop deep understanding of local species and capabilities to transform all types of waste materials - 	<ul style="list-style-type: none"> - DS10.1 - Create spaces that correspond to their use and purpose- 	<ul style="list-style-type: none"> - DS410.2 - Create a safe space for people -

The previous design strategies aim to enhance and start the discussion around the scope of each type of farm. More strategies can be created according to the project and its location.

Fungi Farms

Around the globe, existing initiatives are aware of the positive impacts fungi cultivation holds and the potential it brings when combined with social and economic approaches.

In the map on the right, we classify reference projects we studied into three major categories depending on their aim:

Company

These farms are mainly profit-oriented, they can do low to zero educational activities or societal participative workshops.]

Company with Social Approach

The company has both focus on profit, and education and functions as a production facility while hosting fungi workshops or events regularly to disseminate knowledge related to fungi.

Social Cooperative

The main role of these farms is social. They were created to tackle and solve an existing issue in their local context. For instance, ameliorating soil pollution, diminishing the gender pay gap, or reuse of waste products. The profit of these farms is directed to the optimization of the farm, innovation, and payment for the people involved.

These farms inspired us to decide on which category we would like our proposal for urban mycelium farm to belong, and where on this map does it stand? we decided on a social cooperative., therefore the roles we set in chapter four for Landal Urban Mycelium Farm are aligned with this category.

Furthermore, we identified in the previous chapter which principles we take out and further use in our design of an urban Mycelium farm. These principles which we call referential principles are shown as pink circles at the top of the page.



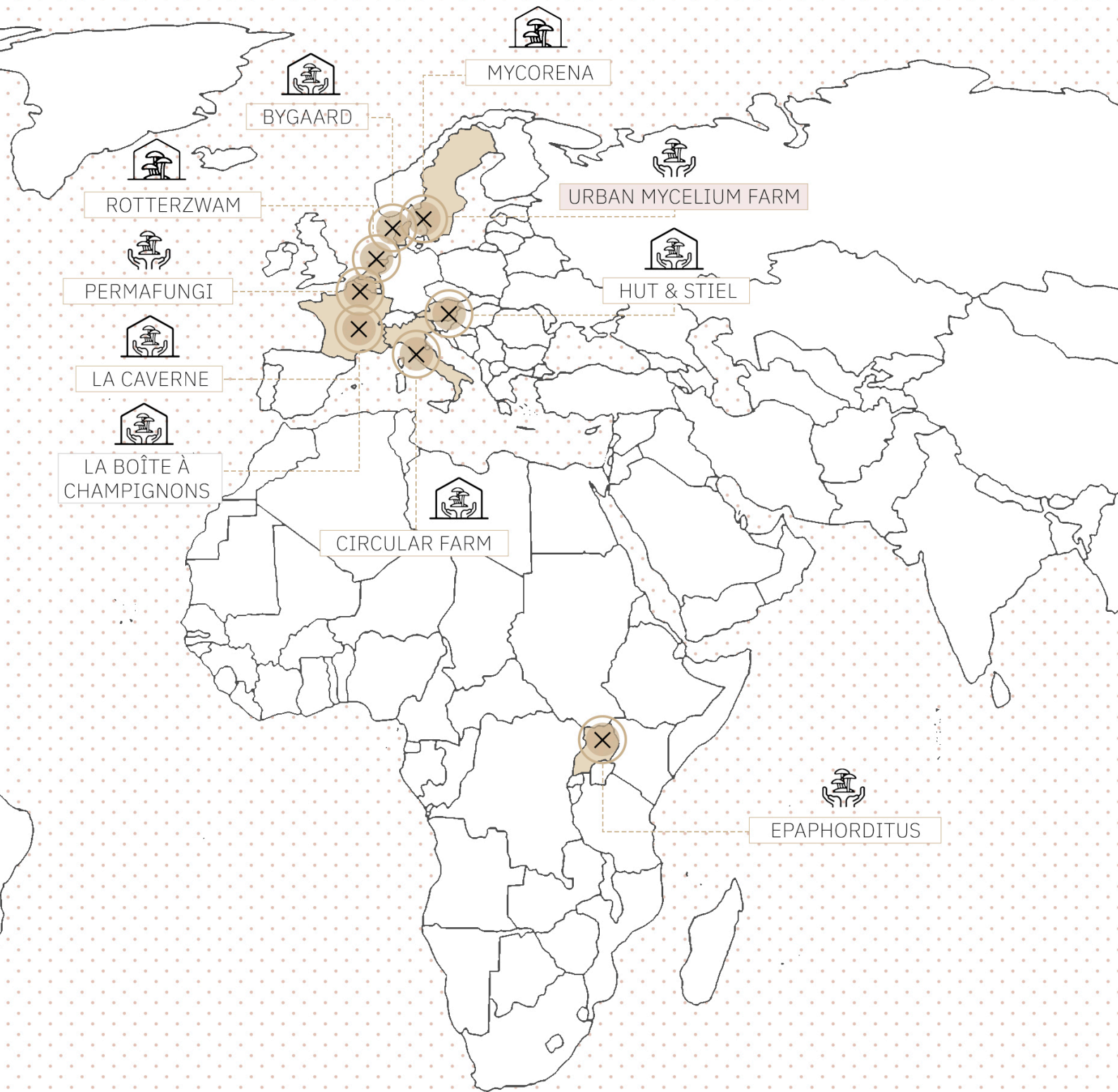

MYCORENA



BYGAARD



ROTTERZWAM



URBAN MYCELIUM FARM



PERMAFUNGI



HUT & STIEL



LA CAVERNE



LA BOÎTE À CHAMPIGNONS



CIRCULAR FARM



EPAPHORDITUS



COMPANY



COMPANY W/
SOCIAL APPROACH



SOCIAL
COOPERATIVE

3.1 Reference Projects Permafungi & La boite a champignons

Reference Principles Derived from the Farm:

PR1 PR4 PR8

Role of the farm: Environment, Society
The core of this project lies in its social approach and re-usage of coffee waste. They organize workshops to engage the local community, create job opportunities for locals, and reinforce a re-usage culture through mushroom cultivation.

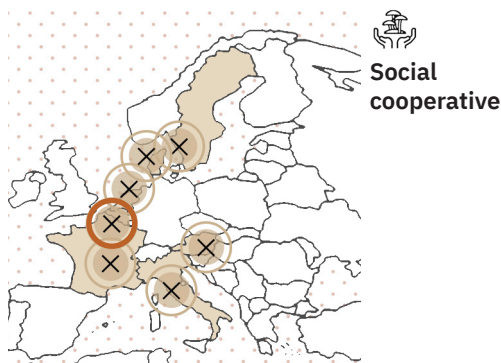

Reference Principles Derived from the Farm:

PR1 PR6 PR8

Role of the farm: Environment, Society, Economy
This project follows a similar discourse around mushroom production for consumption and re-usage of coffee waste from nearby restaurants and cafes.

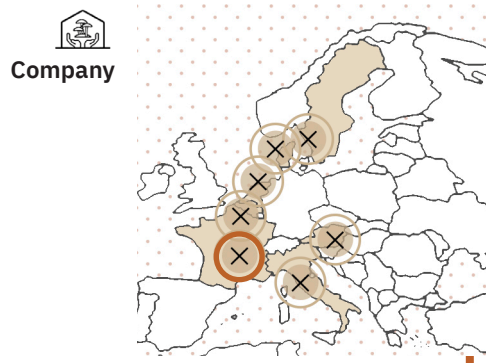

Permafungi
Brussels, Belgium, 2013- Now

Key Stakeholders:

- Residents and Community Members:**
Consumers, Participants in Trainings and Workshops
- Local Government and Regulatory Bodies:** Bruxelles Economie et Emploi, Be Planet, European Union's Life Program
- Private Sector Partners:**
Tour & Taxis, EXK Nature's Kitchen, Le Pain Quotidien
- Community Organizations and NGOs:**
Le Ferme Nos Pilifs
- Bio-based Startups**
PermaLIFE
- Concept:** Social cooperative that recycles coffee grounds as urban waste



Figure 3.1. Permafungi. (PermaFungi | Changer Le Monde Grâce Au Champignon, n.d.)

Cares about:

- Making cities more resilient by:
 - Upcycling waste;
 - Producing healthy and organic food and sustainable products;
 - Creating meaningful jobs for low-skilled people;
 - Becoming independent from fossil energy sources.

Key Learnings:

- Involving society
- Tackling the high unemployment rate among young people
- Creating awareness through guided visits and workshops
- Using coffee waste to create resource symbiosis on a local scale
- Using By-products from oyster mushrooms production for packaging, furniture and isolation.

La boite a champignons
Paris, France, 2013- Now

Key Stakeholders:

- Residents and Community Members:**
Consumers, Users of Mushroom Kits, Coffee waste Providers
- Private Sector Partners:**
Large companies in Ile de Francen
- Community Organizations and NGOs:**
Mission Africa



Figure 3.2. La boite a champignons. (La Boîte A Champignons Culture Des Pleurotes Sur Marc De Café, n.d.)

Concept:

A Company that recycles coffee grounds

Cares about:

Transforming the coffee waste of big companies in France and using it as a substrate to cultivate oyster mushrooms to then sell it to restaurants and distributors.

Key Learnings:

- The possibility of using coffee waste from bigger producers in the city of Gothenburg as food to create mushroom/mycelium farming just as they used coffee waste from big companies in France
- Having a focus on waste awareness and better resource symbiosis in resources.

3.1 Reference Projects La Caverne & BYGAARD

Reference Principles Derived from the Farm:

PR2 PR3 PR5 PR6 PR8 PR9

Role of the farm: Environment, Society, Space
This project started in an unused parking building in the city area of Paris. It takes advantage of urban voids that were dedicated to cars, similar to our current case study conditions.

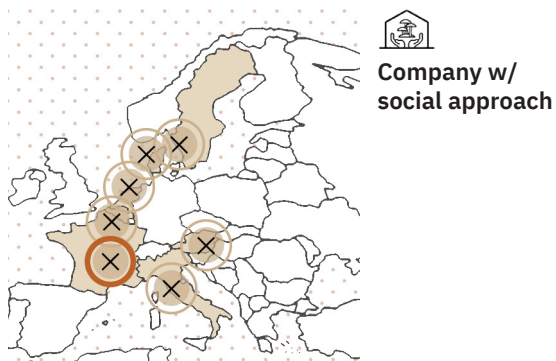

Key Stakeholders:
Residents and Community Members:
Consumers
Local Government and Regulatory Bodies:
France's national state-owned railway company(SNCF) as Parking Lot providers
Bio-based Startups
Cycloponics
Concept:
Urban farm growing up in an abandoned underground parking building in the suburbs of Paris, under social housing.

La Caverne
Paris, France, 2017- Now

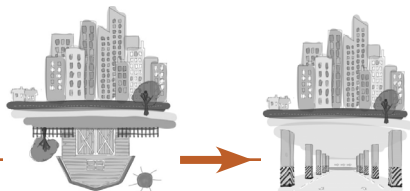

Figure 3.3. La Caverne concept. (La Caverne, Mushroom Houses in the Parking Lots, n.d.)

3

Cares about:
Extending the concept of farming and creating a new virtuous model of agriculture, offering quality local production, while considering the realtions with locals

Key Learnings:

- The 100% CO2-free transport
- Using waste material from other industries to cultivate mycelium, such as Wood
- Creating a new virtuous model of agriculture, offering quality local production in Parking lots
- Establishing a short supply chain
- Minimizing the risk of pollution due to car use of the parking with proper isolation and ventilation
- Conducting educational workshops
- Locally hiring
- Active participation in the transition of the neighborhood

Reference Principles Derived from the Farm:

PR3 PR7 PR9

Role of the farm: Economic
The interesting part of this project is the extensive network of consumers they provide: restaurants, shops, and single customers constitute some of them. Currently, the farm has more than 100 of these connections and they keep on growing.

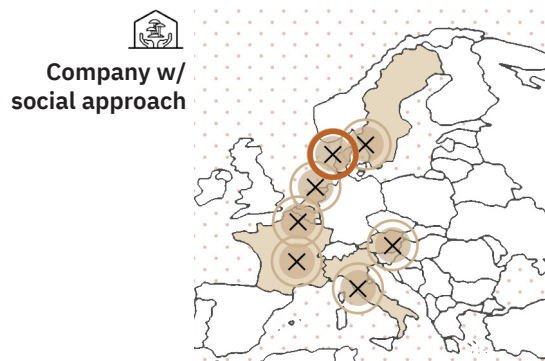

Key Stakeholders:
Residents and Community Members:
Consumers, Participants in visits
Local Government and Regulatory Bodies: Bruxelles Economie et Emploi, Be Planet, European Union's Life Program
Private Sector Partners:
Restaurants and Cafes, Mushroom Substrate from Switzerland

Copenhagen, Denmark, 2018- Now

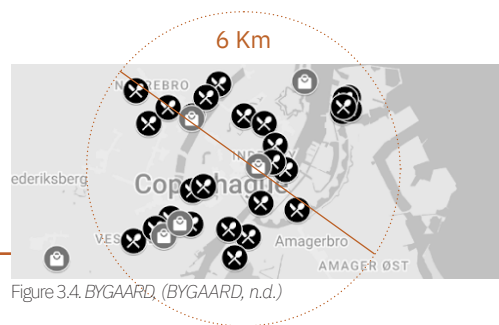

Figure 3.4. BYGAARD, (BYGAARD, n.d.)

4

Concept:
Mushroom farm inside shipping containers.

Cares about:
Local and responsible food production system.

Key Learnings:

- Using containers as work space, allowing them to have a modular and transportable farm concept.
- Using waste material from other industries to cultivate mycelium, such as Wood shavings, sawdust, and straw.
- Having 6 km distribution distance to stay in the 100%-transport carbon emissions

BYGAARD

3.1 Reference Projects Amisacho & RotterZwam

Reference Principles Derived from the Farm:

PR4 PR6 PR8

Role of the farm: Environment, Society, Space
Amisacho project has the objective of healing soils the private oil company Shell polluted through years of extraction. Fungi are used to clean organic pollutants, do research on medical products and build a strong, organized and participative community.



Key Stakeholders:

Residents and Community Members:

Ecuadorian Amazon communities

Academic and Research Institution:

Social Ecologies

Community Organizations and NGOs:

Red de Guardianes de Semillas, Udapt, Los Ysapas, Love For Life,

Bio-based Startups

Clinica Ambiental



Figure 3.5, Amisacho (Amisacho – Cultivo De Hongos)

Concept:

Making an edible and medical mushroom farm and biological research laboratory

Cares about:

Promoting dynamic strategies to raise ecological awareness in Ecuadorian Amazon communities coping against toxic environmental conditions and effects of environmental and social injustice.

Key Learnings:

- Holding a holistic approach integrating: human health, ecological health, culture revitalization, and economic justice.
- Emphasizing community and collaborative resilience

Reference Principles Derived from the Farm:

PR3

Role of the farm: Environment, Economy, Society
This farm stands out because of its location. Using an unused water park facility, they gradually adapted the available spaces to each one of the steps in mushroom production.

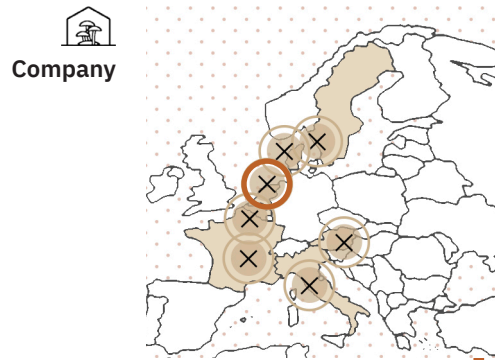

Key Stakeholders:

Private Sector Partners:

Large businesses providing their coffee waste, e.g. JDE

Community Organizations and NGOs:

B Lab

Residents and Community Members:

Consumers, Volunteer, Workers, Cyclists, Participants of workshops

Bio-based Startups

Blue City



Figure 3.6, RotterZwam (rotterzwam, n.d.)

Concept:

It is an organized society that cultivates mushrooms from local residual flows, creating a mushroom farm in an abandoned water park.

Cares about:

- Reusing coffee grounds and producing oyster mushrooms and snacks.
- Having close local loops, creating awareness about sustainability and circular economy.
- Saving coffee from incineration, instead using it for cultivation and composting, reducing CO2 and nitrogen emissions.

Key Learnings:

- Abandoned spaces with scarce access to light can be a great opportunity for mushroom urban farms.
- Showing a long-term profitable business, 10 years since their inauguration and still growing.

Amisacho

Nueva Loja, Ecuador, 2006- Now

5

RotterZwam

Rotterdam, Netherlands, 2006- Now

6

3.1 Reference Projects Hut & Stiel & Epaphroditus

Reference Principles Derived from the Farm:

PR1

Role of the farm: Environment, Society, Space
They focus on the circularity of the product and how to optimize yields from each step in the process of production.

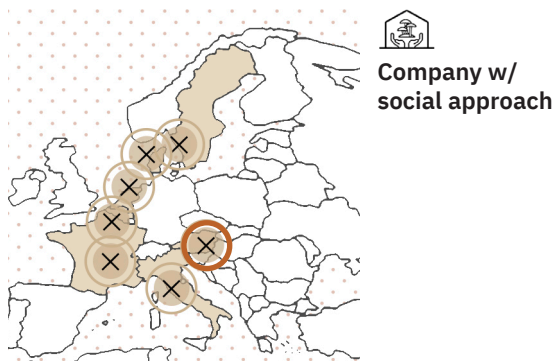

Key Stakeholders:

- Local Government and Regulatory Bodies:**
The Chamber of Labour (Arbeiterkammer or AK), Erste Group Bank AG
- Private Sector Partners:**
Providers of coffee waste, e.g. coffee houses, restaurants, commercial kitchens and offices, and hotels
- Residents and Community Members:**
Consumers, Participants of workshops



Figure 3.7, Hut & Stiel (Hut Und Stiel, n.d.)

Concept:

Startup mushroom farm using leftover coffee grounds

Cares about:

Collecting leftover coffee grounds and producing oyster mushrooms.
Sharing knowledge about mushrooms and their cultivation process through workshops changing food production and shaping economic, sustainable, and social change.

Key Learnings:

Offices and workplaces where coffee is consumed can be also incorporated in the circularity of the chain.

Reference Principles Derived from the Farm:

PR4 PR6 PR8

Role of the farm: Society
This farm in Africa started with the objective of giving economic stability to local women through mushroom cultivation.



Key Stakeholders:

- Residents and Community Members:**
Impoverished rural Ugandan women
- Academic and Research Institution:**
Institute of Electrical and Electronics Engineers (IEEE)
- Community Organizations and NGOs:**
Local church, Africa Development Promise

Concept:

Female-led growing mushroom cooperative



Figure 3.8, Epaphroditus Women's Cooperative / Africa Development Promise (Rise 2021)

Cares about:

- Improving social-economic conditions by collective action of rural entrepreneurial women to advance sustainable business and economic independence in African communities.
- Signing official contracts with women in poverty as "outgrowers" and providing training, tools, and a small hygienic structure to harvest mushrooms at a household level.

Key Learnings:

- Implementing urban mushroom farming model to empower low-income women and families, teaching them mushroom farming and giving them economic and financial resilience.
- Understanding the value of cooperation first and then with time, addressing sustainability, and relevance to reach people.

Hut & Stiel

Viena, Austria, 2015- Now

7

Epaphroditus Women's Cooperative
Africa Development Promise

Uganda, Africa, 2013- Now

8

3.2 Own Projects

Urban Mycelium Farm in Gamlestad

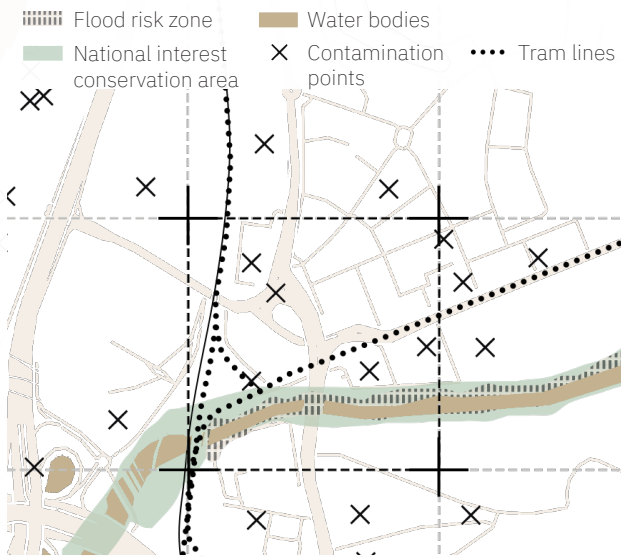
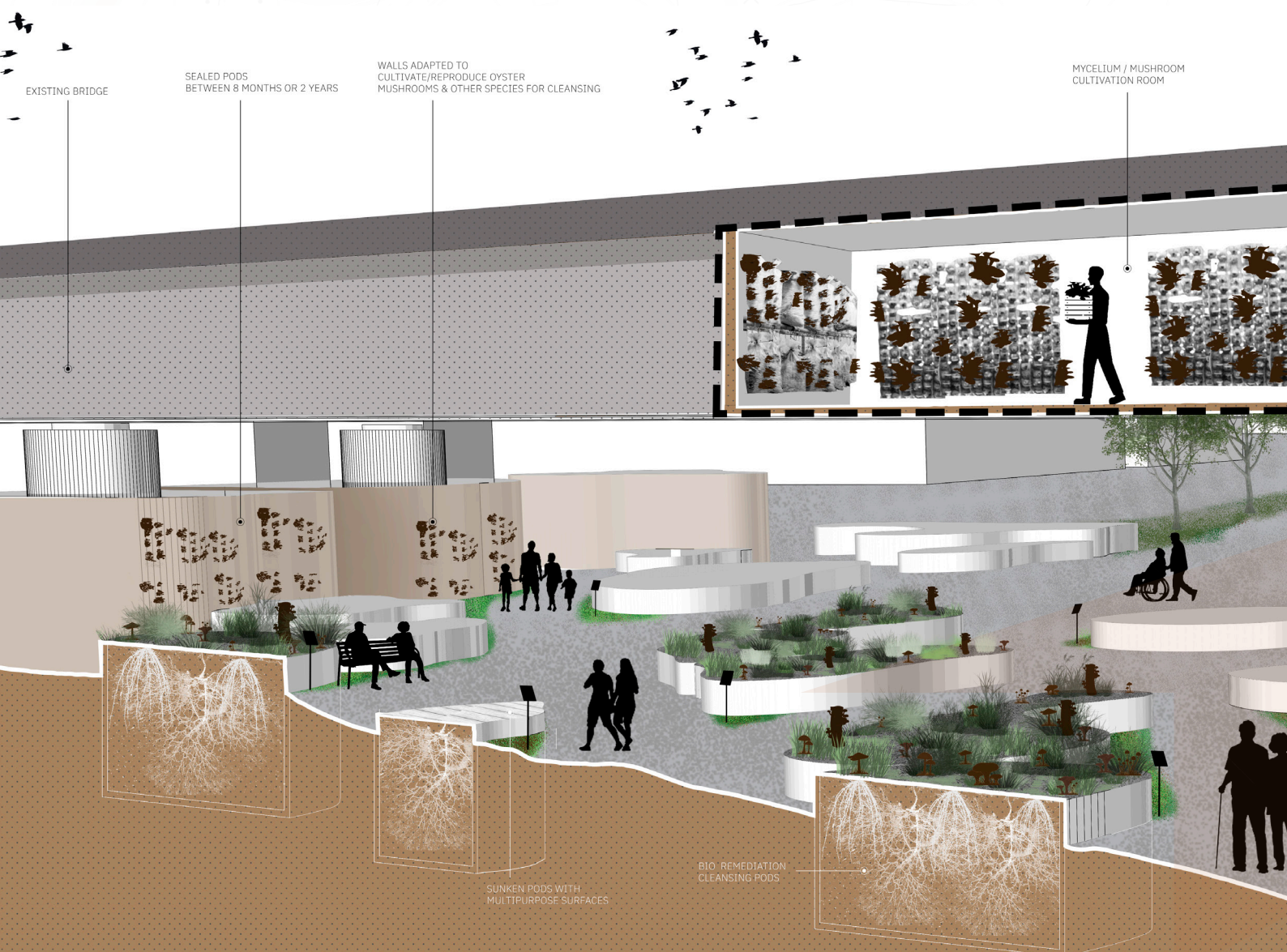

Figure 3.9. Site location map and pollution points. (Own authorship)

The Urban Mycelium Farm project in Gamlestad was developed by Alonso Martinez during the Urban Prototypes studio at Chalmers. The objective was to design an urban intervention that attends the cleansing of soil by bioremediation strategies while also functioning as a public space and production hub. The project is expected to strengthen social bonds and common interactions among locals and residents. This will be achieved by creating spaces for education, learning, leisure, exploration, and production of fungi-based products while preserving local biodiversity.

With this in mind, I created a soil-containing prototype that could be used for mycoremediation. This pod will be replicated across the entire intervention area to create connection paths, recreation areas, and dynamic public spaces.



3.1 Reference Projects

Urban Mycelium Farm in Gamlestaden

The urban void selected for this farm is located under a bridge. The bridge is proposed to be used as a load-bearing structure to support the community space for fungi cultivation, this protects the farm from extreme flooding scenarios.

Overall, the projects showcase a different example of how mycelium farming can be incorporated into the city's urban fabric by transforming urban voids into spaces that build community and better welfare conditions for all species in the ecosystem including us.

MIXED LOCAL PLANTS & AND FUNGI TO CLEANSE THE SOIL

REMOVABLE MULTIPURPOSE SURFACE

ORGANIC DESIGN THAT FOLLOWS MOVEMENT

SEALED CONTAINER FROM 8 MONTHS UP TO 2 YEARS TO CLEANSED SOIL WITH FUNGI

CONTAINED TREATED SOIL IN-SITU

SOIL INJECTED WITH MYCELIUM SPAWN TO TRIGGER MYCOREMEDIATION PROCESSES

ACCESS TO CULTIVATION & WORKSHOP ROOMS, BIO-BASED CLADDING MATERIALS AND BEARING STRUCTURE

EXHIBITION / WORKSHOP LEARNING ROOM

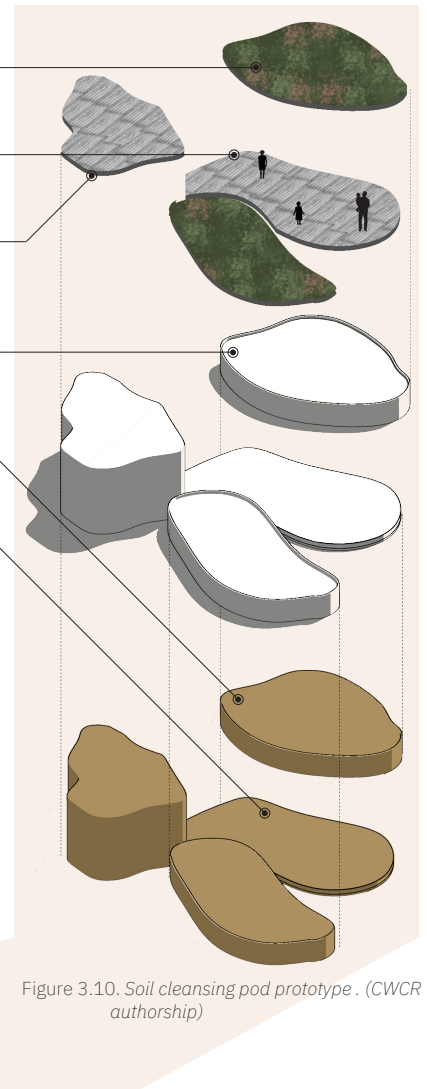
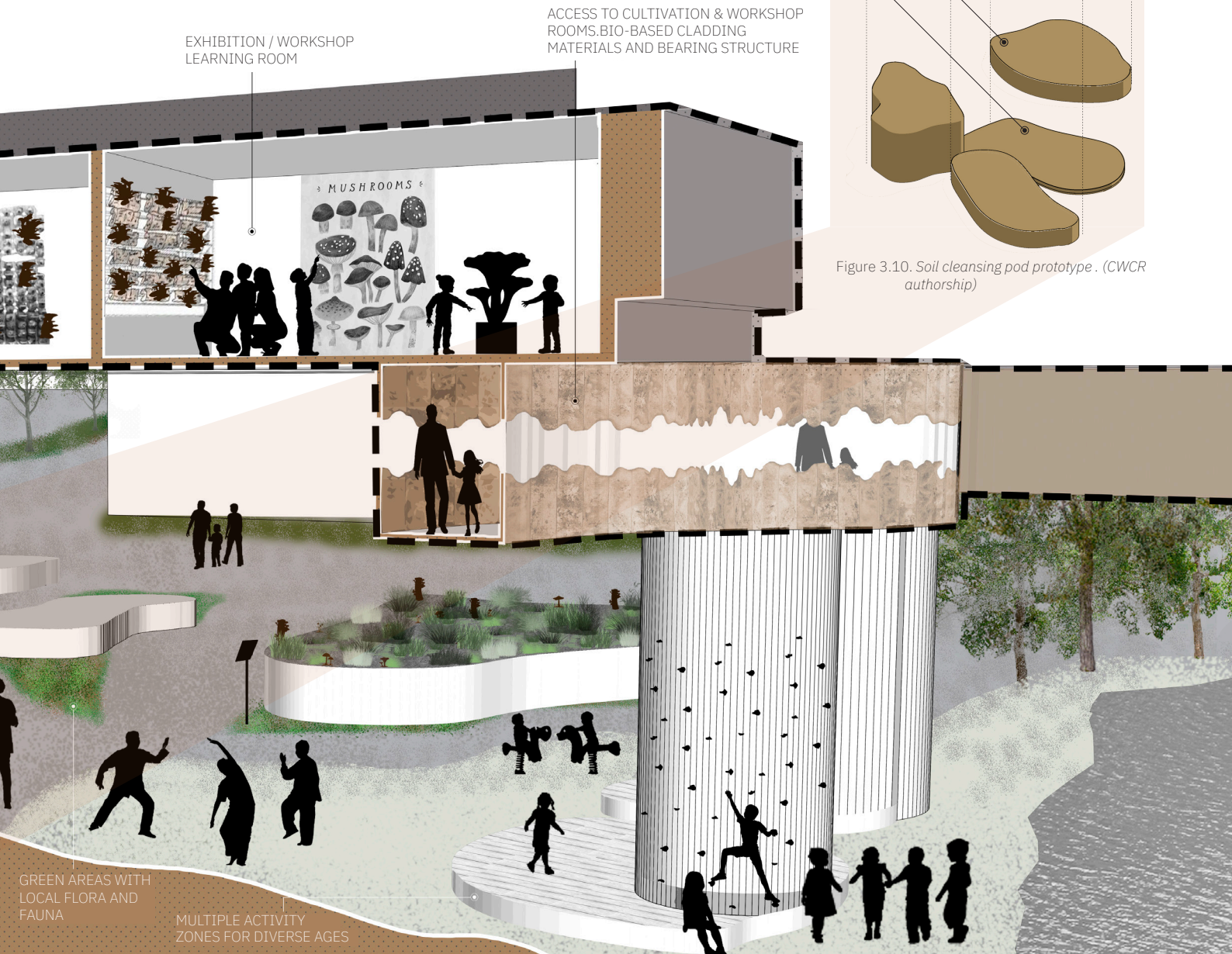

Figure 3.10. Soil cleansing pod prototype. (CWCR authorship)



GREEN AREAS WITH LOCAL FLORA AND FAUNA

MULTIPLE ACTIVITY ZONES FOR DIVERSE AGES

3.2 Own Projects

Common waste - Common resources (CWCR)

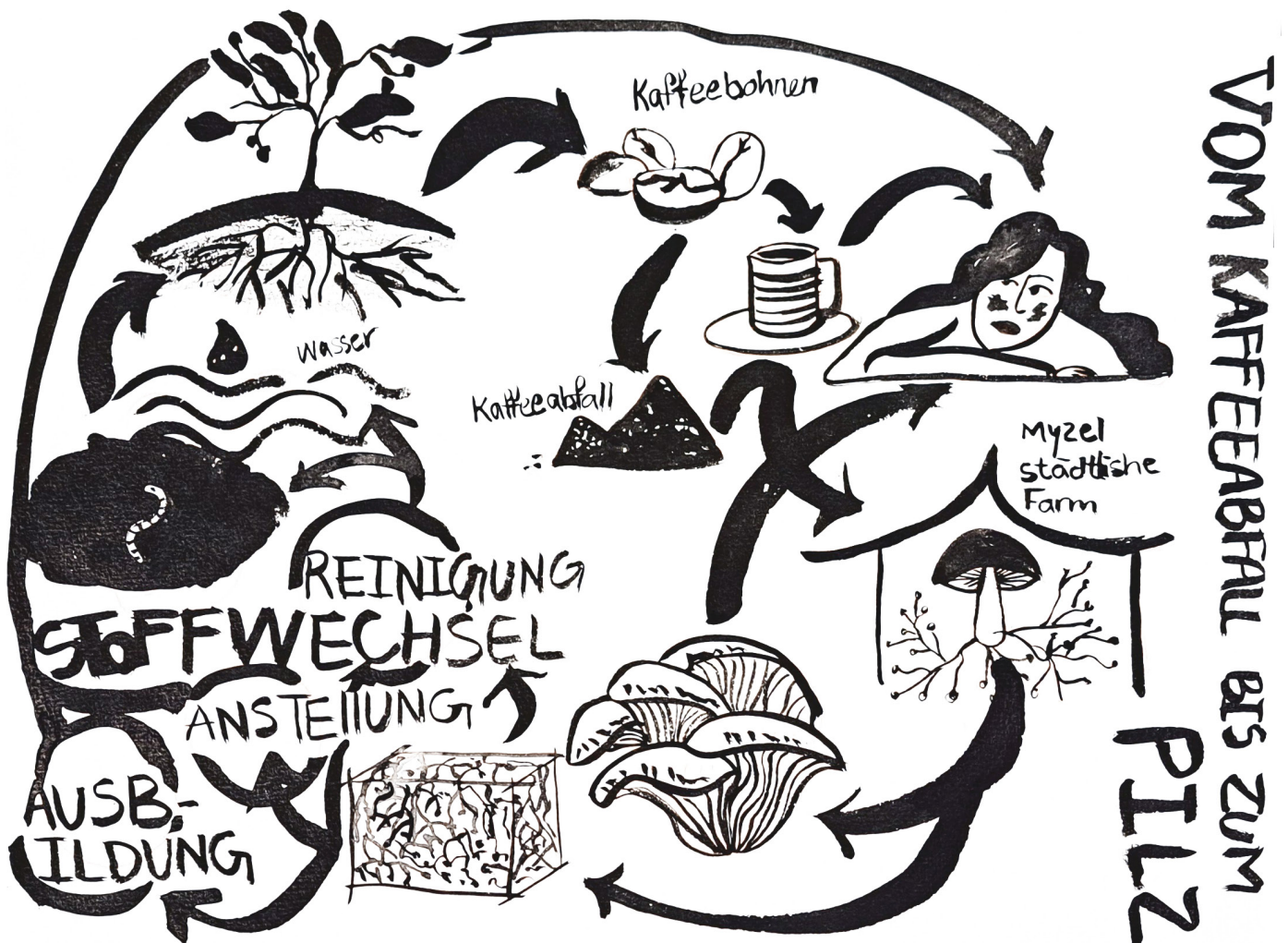

Figure 3.11. Invitation calls for the neighborhood to contribute their household biowaste for the project. (CWCR authorship)

This project is located in a neighborhood near Ostbahnhof in Berlin, developed by Common waste - Common Resources team which Ala Talebian was part of. The aim is waste management teaching and how simple steps of identifying input and output resource systems can change a neighborhood's vision regarding sustainability.



Figure 3.12. Posters to raise awareness and spread knowledge about composting (CWCR authorship).



54 Figure 3.13. From coffee waste to mushrooms. Poster made for neighborhood community awareness (Own authorship)

3.2 Own Projects

Common waste - Common resources (CWCR)

Many efforts were conducted to involve the community. Screening weekly movie nights (Fig. 3.14), starting discussion sessions with the public, designing workshops and posters, and sending out invitations around the neighborhood to collect organic waste and involve it in the process of composting. The final outcome was to have healthy soil and increase awareness in the community.

Part of the awareness effort involved creating a set of simplified advanced information for the public so they learn and benefit from resource provenance. As an example, Figure 3.13 shows how the daily habit of drinking coffee produces coffee waste that can be transformed into edible mushrooms and mycelium blocks that in return have the capability to cleanse our soils, and water and create jobs.

It is important to include community engagement in order to reach sustainable goals at a neighborhood level. This also applies to mycelium farms, showing us the relevance of community participation in this type of project to function and reach their maximum potential.



Figure 3.14. Having movie sessions with an open invite to raise awareness about resource flows. (CWCR authorship)

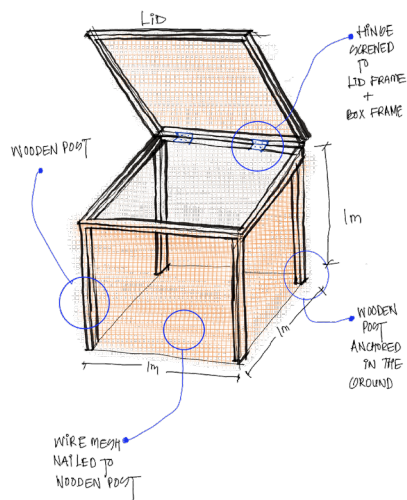

Figure 3.15. A compost bin was designed and built and the organic waste of the participants was gathered in a duration of two weeks. Compost bin illustration (CWCR authorship)



Figure 3.16. Participants looking to microorganisms collected from the biomass. (Top left). Microorganisms collected from biomass. (Top right). Building of compost bin and temperature check-up to demonstrate the ongoing process of composting. (Bottom left). Set up of protective cover on the prototype. (Bottom right) (CWCR authorship)



This section will address our case study location from a city scale, neighborhood scale, and building scale. We take into account existing transport infrastructure, access routes, land uses, population density, public spaces, possible stakeholders, and centrality analysis to have a solid foundation to develop the design process.

4.1 The Roles Of Landala Urban Mycelium Farm

The roles of Landala Urban Mycelium Farm

In Chapter 4, we explain our specific case study in the city of Gothenburg. We made the decision to create a farm with 3 main roles:

Society: Education, Awareness

Raising awareness and educating the community are crucial steps as they build a knowledge base that fosters the continuity of the practice and encourages local businesses, schools, and residents to collaborate, providing resources, space, and support for the farm.

Environment: Waste Transformation, Research

Utilizing waste transformation, specifically coffee waste in our case, for mycelium farming creates a sustainable model for urban waste management, showcasing a practical solution for reducing waste and fostering a more sustainable and resilient urban ecosystem and city.

Research helps in the continued growth and optimization of the farm leading to more accessible and sustainable farms.

Economy: Food Production

To bring back the possibility of food and other production systems to city centers and fight the potential food scarcity

As mentioned in Chapter two, a generic architectural spatial requirement (p. 41) is to prioritize the use of urban voids (unused or under-used sheltered spaces). Therefore, our proposal is tied to urban voids and under-used spaces in the city. We envision Urban Mycelium Farms as catalyzers merging an efficient flow of resources and waste while bridging society with the local biodiversity.

We believe Gothenburg is ready to accept our proposal based on the Gothenburg City Museum project «Gothenburg Stories», where 100 citizens from different backgrounds and neighborhoods are interviewed with questions ranging from their mobility within the city, how their neighborhood, and what it means to live in Gothenburg (Göteborg berättar, 2024).

The interview responses show that the citizens of Gothenburg want to contribute to making the city better. Of importance to our thesis is that this exhibition confirms that there is a general awareness among citizens about the problems of the city and that action is needed. Many specify the need to bring people together from various backgrounds and this showcases the readiness of Gothenburg for accepting the mycelium urban farm concept as catalyzers for the community.

Bridging natural
and urban enviro
27-37

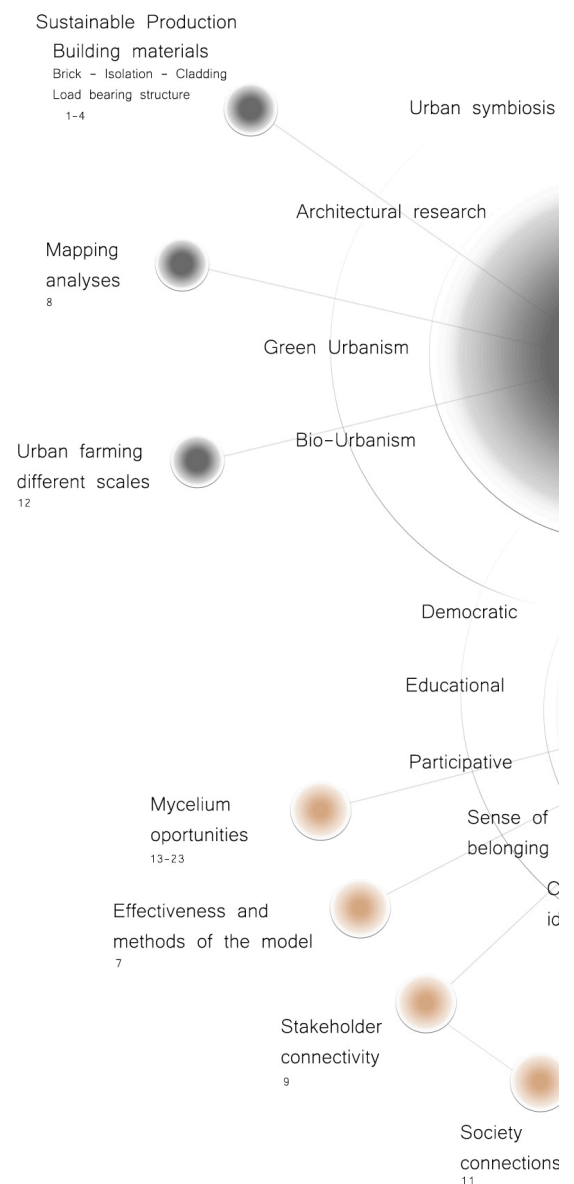

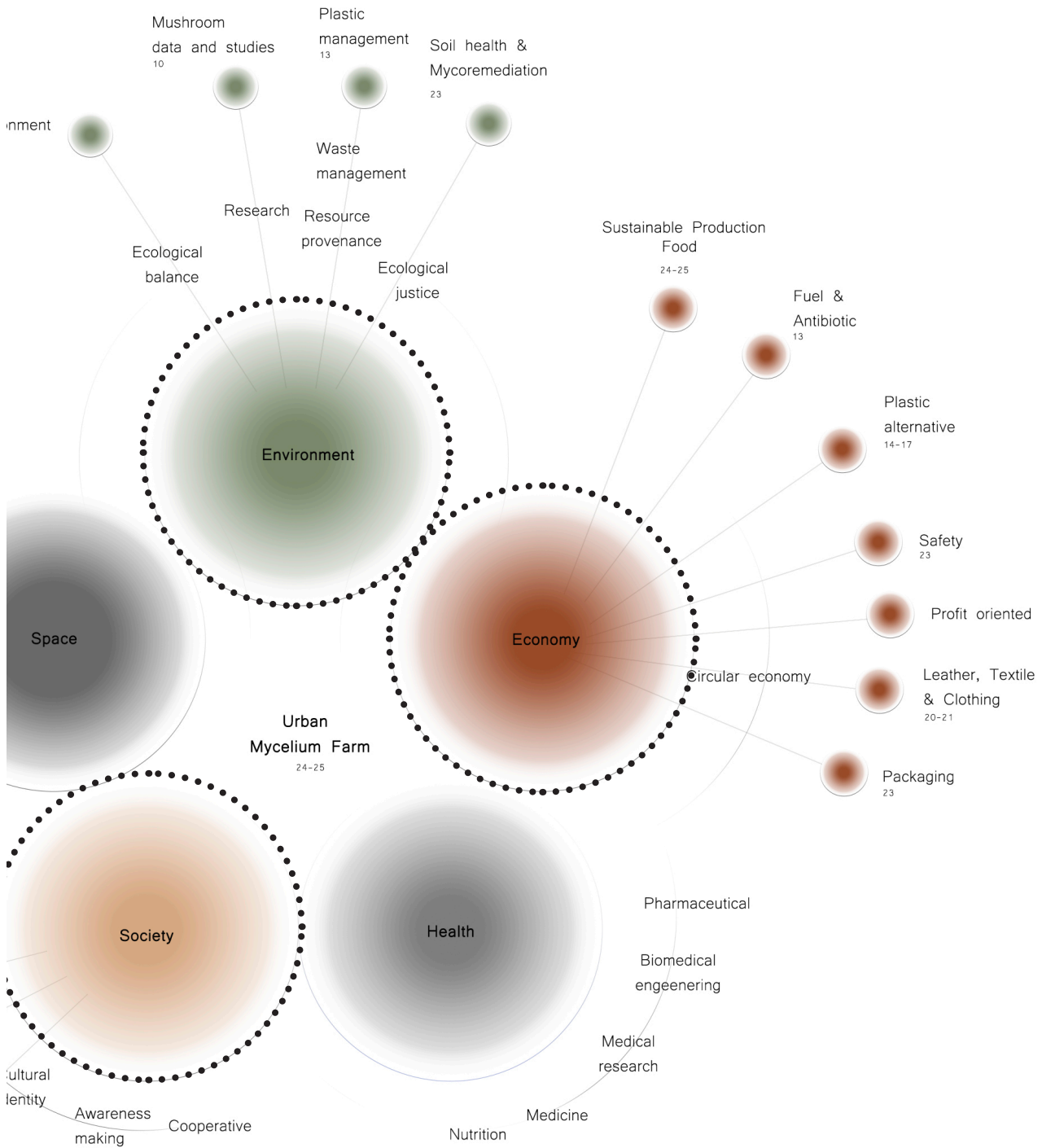

4.2 The Steps In The Design Process

Pairing the local studies, spatial requirements and design strategies led us to the design proposal. To reach this proposal, we break down the design process in the diagram below (Fig.4.2), showcasing each one of the steps we followed.

In a broader scope, if a mycelium farm wanted to be reproduced in other location in the city or any other city, these steps can be followed applying the tools and categories showed according to the local context conditions.

Each step is composed of tools or subcategories that help us understand and structure the decisions made. From all the tools and subcategories, we mark in red the ones we specifically applied to our case study in Landala.

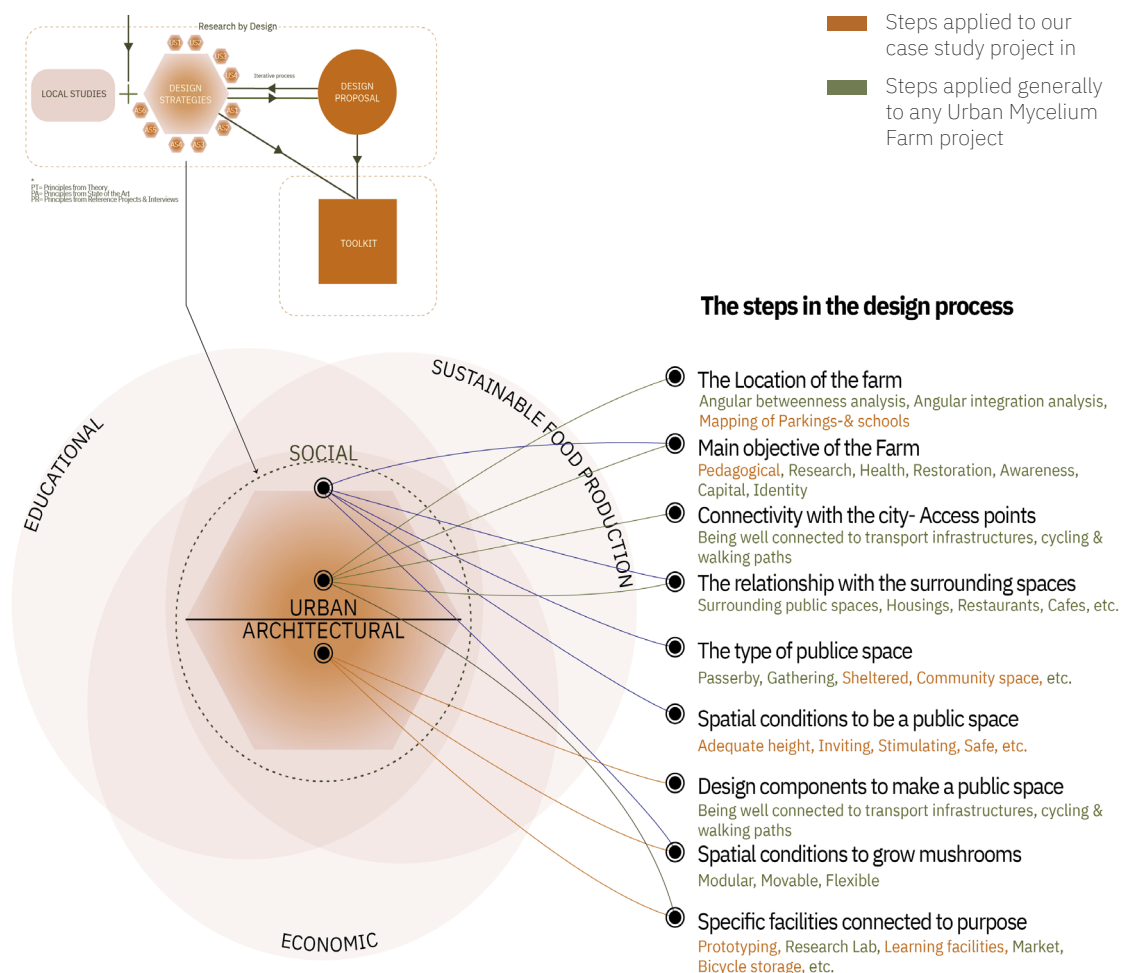

Fig 4.2. Diagram showing the main objectives of the farm in Landala and the steps in the design process. (Own authorship)



4.3 Site Analysis

Location & objective

Based on the role of society: education and awareness, we needed our farm to be located close to educational institutes and specifically, a school. Additionally, considering spatial requirements, the urban mycelium farm needs a sheltered space while prioritizing urban voids. Therefore, schools and urban voids that can be transformed into farms (sheltered parkings) were mapped. The better the connection a parking garage has with schools, the easier the process of awareness-making among locals regarding this new method of co-production.

Secondly, these locations were overlapped with angular betweenness analysis to find the best possible intervention zones. At this stage, sheltered parking garages within the dashed square have the optimum location.

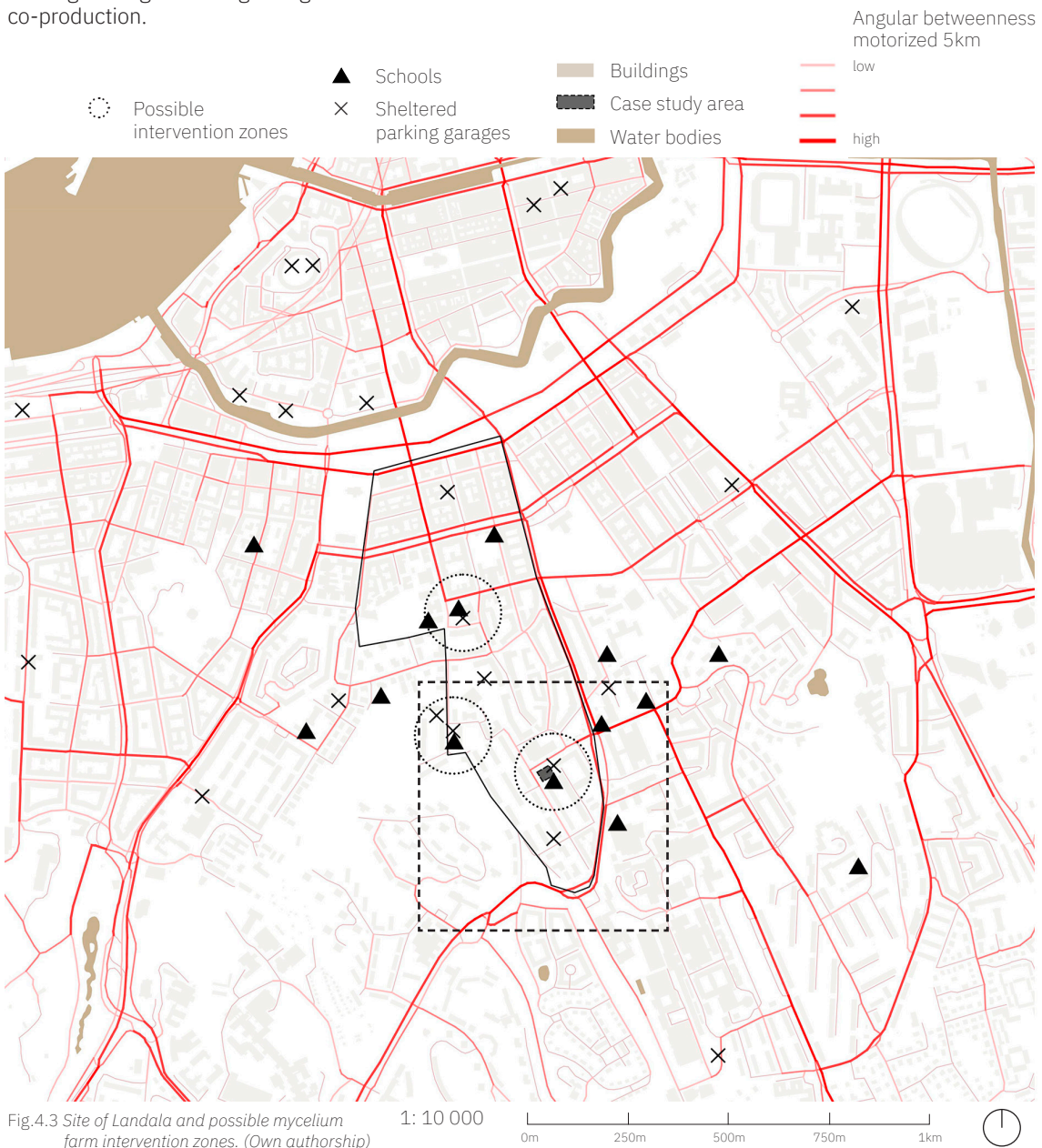

Fig.4.3 Site of Landala and possible mycelium farm intervention zones. (Own authorship)

4.3 Site Analysis Accessibility

From the intervention zones, we selected the one close to Kapellplatsen due to its high betweenness compared to the other sites, its proximity to cycling infrastructure, how close it is to bus stops and tram stations within walking distance, and its direct connection to a school. (Fig.4.4)

- | | | | |
|---|-----------------|---|------------------------|
| ○ | Tram stops | — | Cycling infrastructure |
| × | Bus stops | ⋯ | Walking distance |
| ■ | Buildings | — | Tram tracks |
| ■ | Chalmers | — | Motorized roads |
| ■ | Case study area | — | Non motorized roads |
| □ | Landala | ▲ | Shared biking station |
| | | ○ | Tram stops |

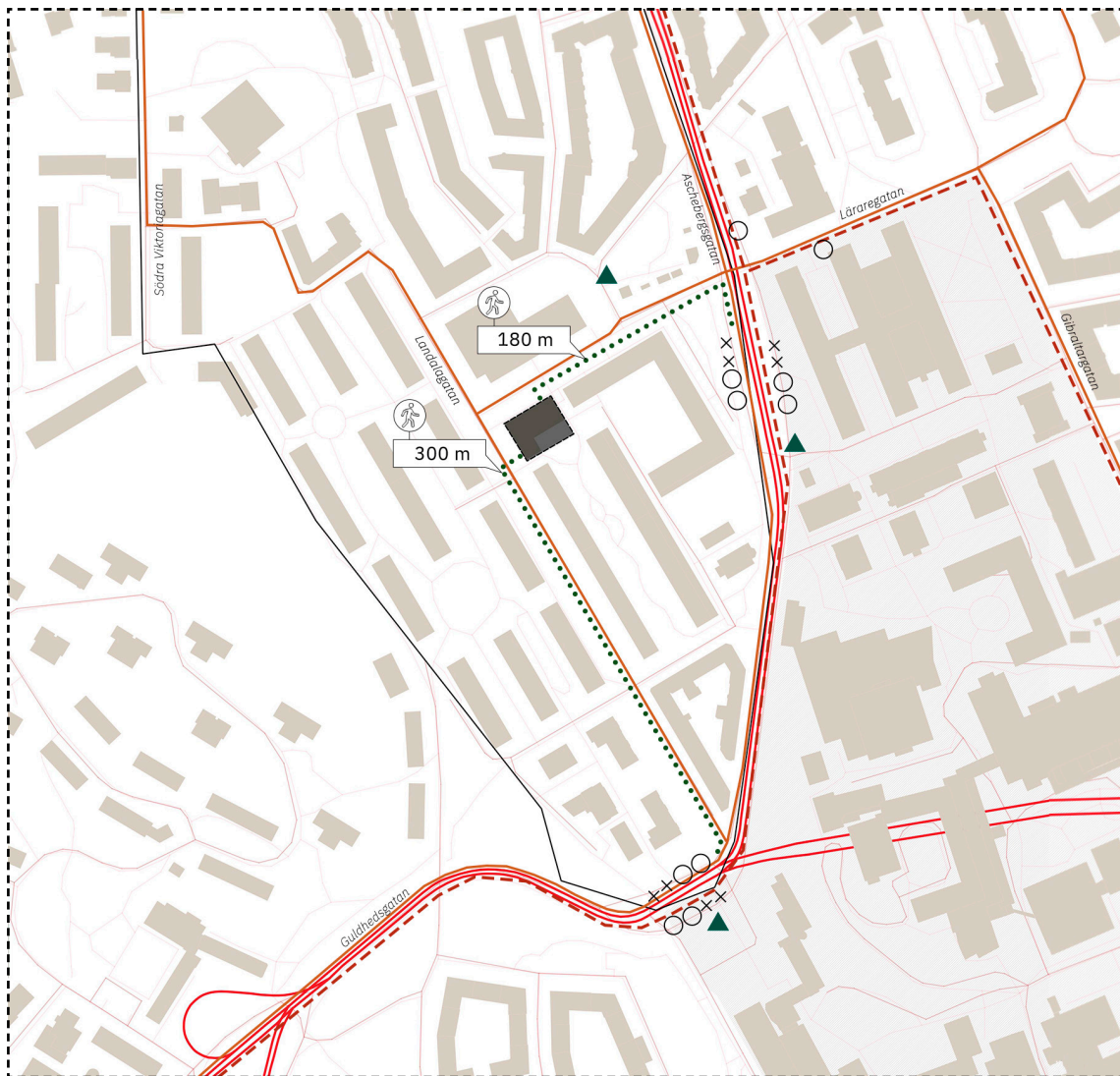

Fig.4.4. Site of case study in Landala and proximity to transport infrastructure. (Own Authorship)

4.3 Site Analysis

Connectivity

Scaling down to our case study area, we picked an underground, partially public parking space next to Kapellplatsen. The parking area is located below ground, with an elementary school built on the upper levels. It is located at the intersection of Landalagatan and Läraregatan streets in a high-activity zone due to commerce, residential uses, educational facilities, services, and leisure the area offers (Fig. 4.5). It is connected to cycling routes and public transport within less than 200m walking distance, making it accessible to different users.

Through multiple site visits on different dates and distinct times of the day, we recognized the parking space as an under-used space in Landala, not even reaching 70% of its occupation at any of the visits.

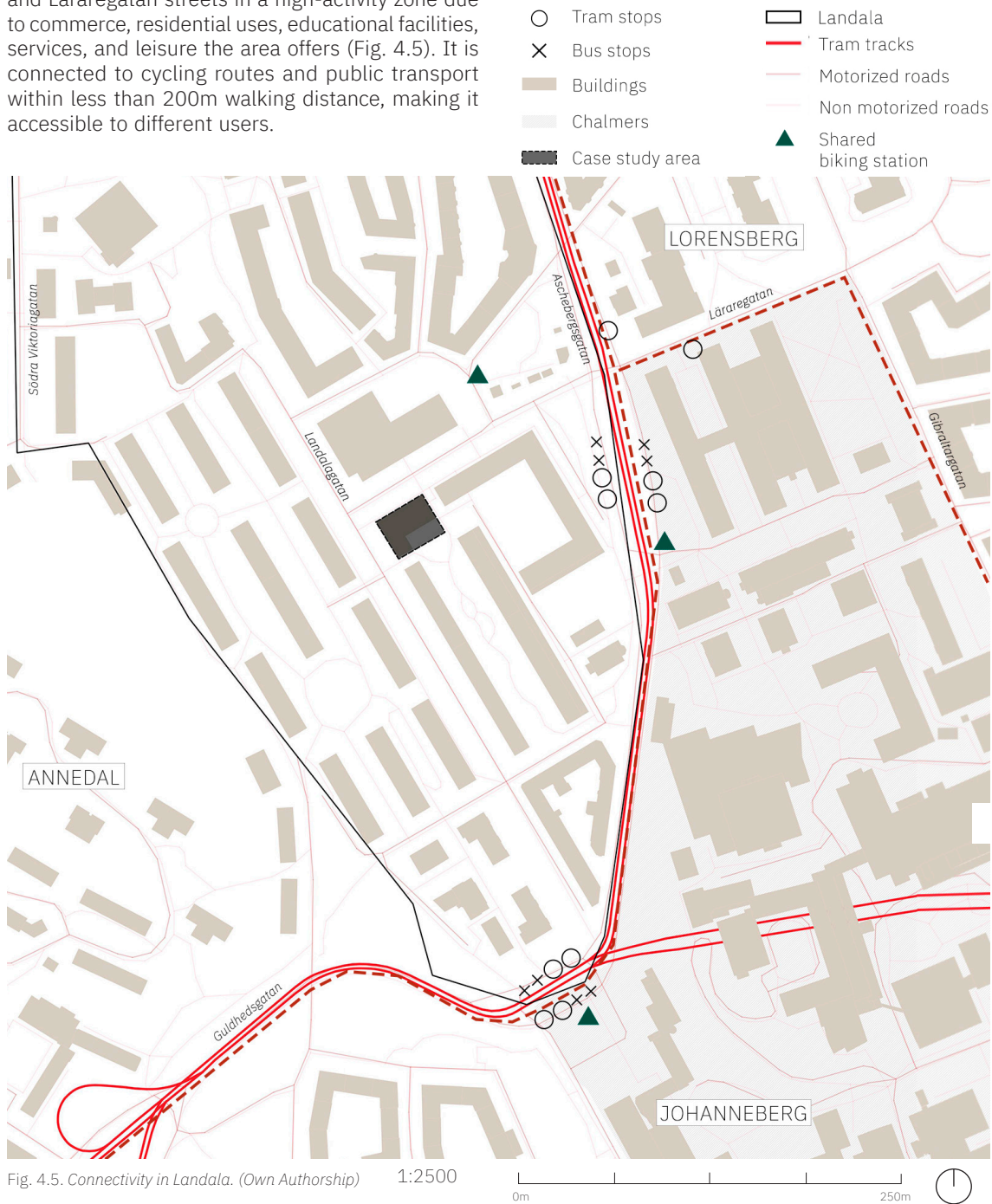

Fig. 4.5. Connectivity in Landala. (Own Authorship) 1:2500

4.3 Site Analysis

Density & Betweenness

According to our previously established spatial requirements, we combined population density per hectare and betweenness analysis maps to show how our case study area is connected to streets that expect high flows of people while also holding high density. These two factors contribute to creating a stronger network of stakeholders and resources that will nurture and benefit from the mycelium farm.



4.3 Site Analysis

Land uses

According to the previous analysis, more than 70% of the land use in the area is dedicated to housing, shifting into mixed-use contiguous to Kapellplatsen at a street level. A major part of the economic activity happens around this cluster, which mixes commerce, services, and residential with public open and semi-public spaces.

The selected case study area holds strong potential as a production/community space in terms of connectivity with surrounding public spaces and activities. Since it is sheltered, the proposed community space will be available for residents the whole year-round regardless of weather conditions.

- | | | | | | |
|-------|--------------------------|---|------------|---|------------------|
| ----- | Public space connections | □ | Study area | ■ | Housing |
| ▨ | Sheltered p. space | ■ | Commerce | ■ | Housing/Commerce |
| ▧ | Unsheltered p. space | ■ | Services | ■ | Housing/Services |
| | | ■ | Education | | |

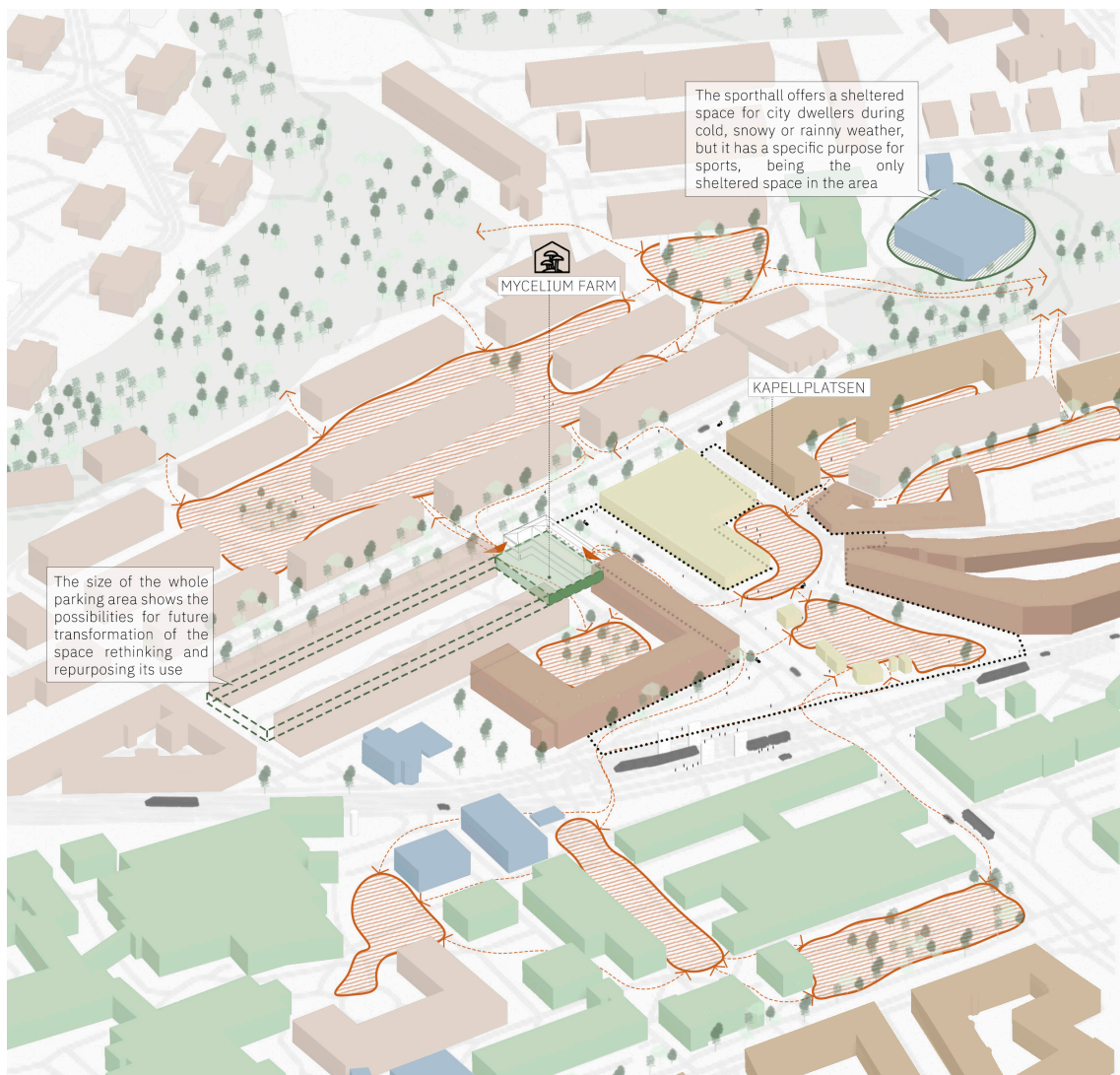

Fig 4.8. Land uses and unsheltered public spaces in Landala. (Own authorship)

4.3 Site Analysis Land uses

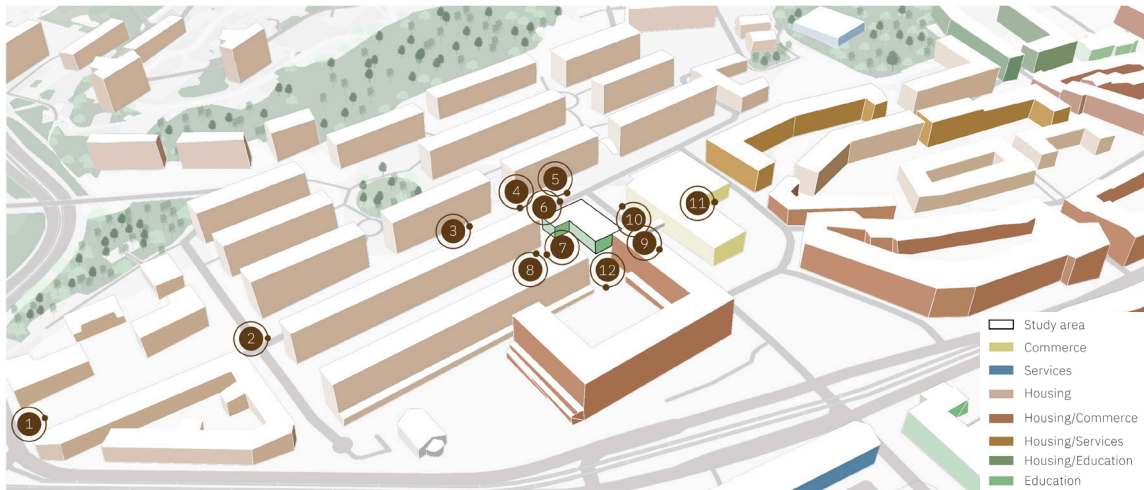

Fig4.9. Landala land use. (Own Authorship)



Fig 4.10. Landala scenes. (Own authorship)

4.3 Site Analysis

Land uses

The site's location is connected to multiple public and partially public zones in the district. This opens the possibility of integrating the farm into a broader network of common public areas and services, creating new stakeholder relationships and activities.

More than 70% of the buildings in the area are dedicated to housing, while some buildings completely function as residential, a few of them allow commerce use at a street level, shifting to residential on the upper floors. (Fig.4.9)

It is noticeable to spot through the site images, the presence of people in public compared to partially public spaces, having the highest concentration of people in Kapellplatsen. (Fig.4.12)

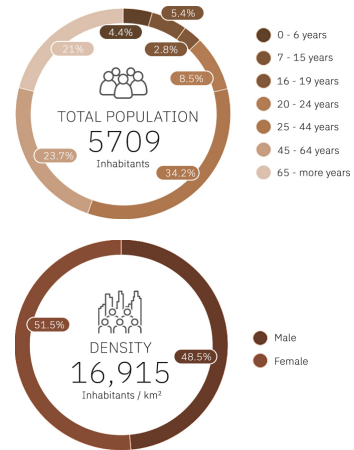

Figure 4.11 Source: Statistkmyndigheten [online] for data. (Graphics own authorship)



Fig 4.12. Existing parking area envisioned to be a mycelium farm. Main connective streets and public spaces in the area. (Own authorship)

4.3 Site Analysis

Public spaces

As a public space itself, we propose the farm to also function as a community-oriented zone where people can gather to learn about mycelium/fungi-related topics, and resource flows within the city or simply have a sheltered public space to rest and enjoy, offering a link to nature through a design that stimulates curiosity, exploration, community and participation.

- Distribution/collection points (exemplification)
- Cycling routes
- Unsheltered p. space
- Sheltered p. space

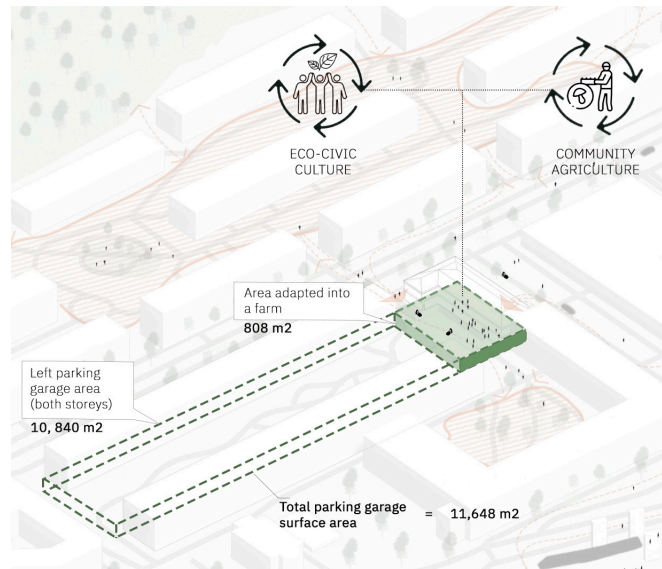

Figure 4.13. Neighborhood public spaces (Own Authorship)



Fig. 4.14 All the existing public spaces in the neighborhood are unsheltered (Own authorship)

4.3 Site Analysis

Space analysis

The underground parking space we decided to choose as the case study has approximately 648,11 m² divided into two floors. The upper floor is a private parking area for residents and the lower floor is where we envision the main floor of the farm to be located, the surface designated for the farm is 808 m², and the rest of the story is kept as private/public parking area just as it is now. (Fig.4.15) The area has main access routes, vehicle/pedestrian by Landalogatan and only pedestrian by Läraregatan. (Fig.4.16)

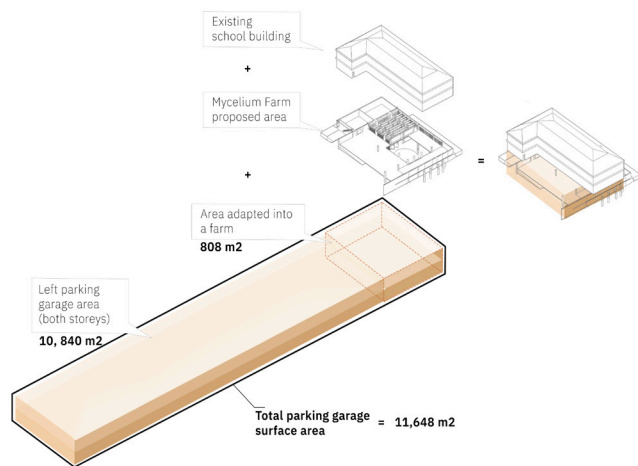

Fig 4.15 Case study area and division. (Own authorship)

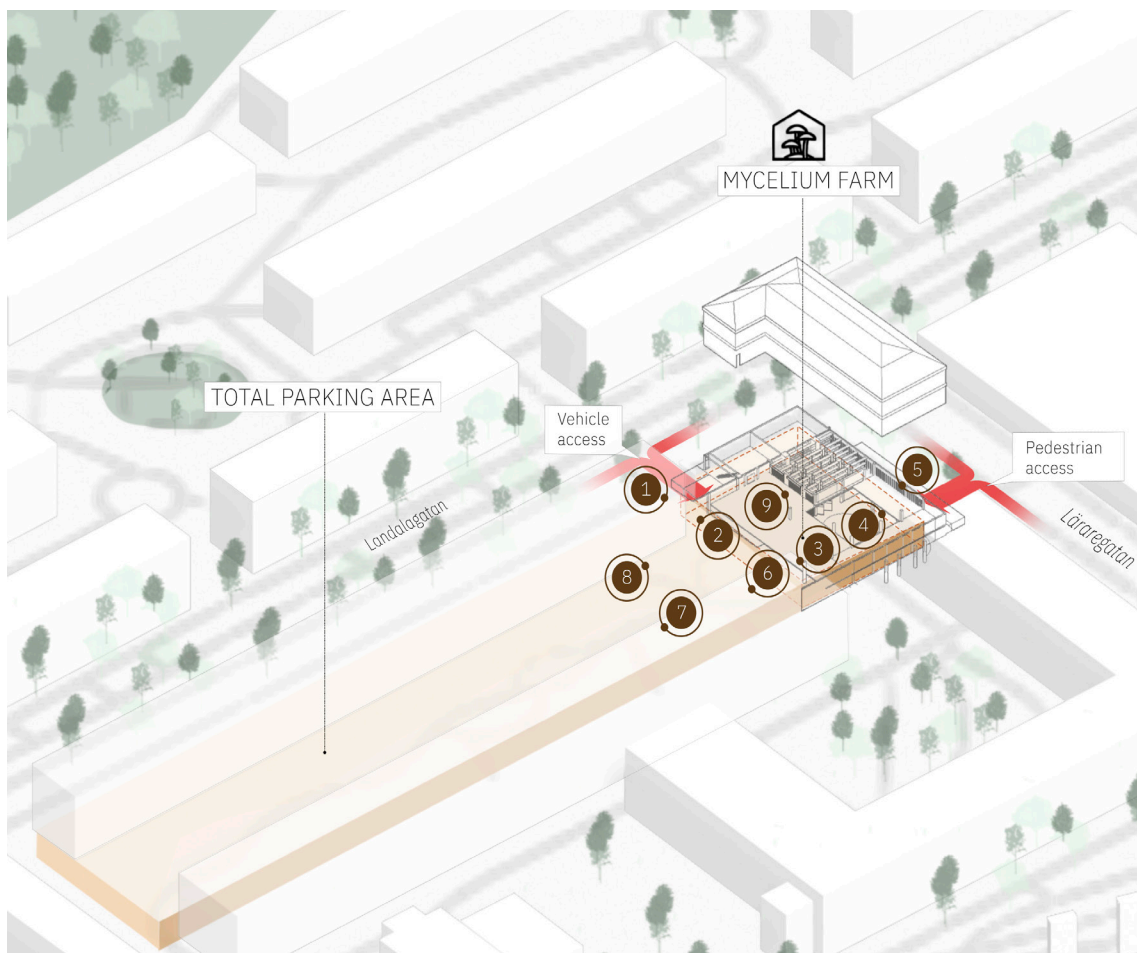

Fig 4.16. The numbers are related to the photos of next page showcasing the existing interior of the Landala Parking. (Own authorship)

4.3 Site Analysis Space analysis

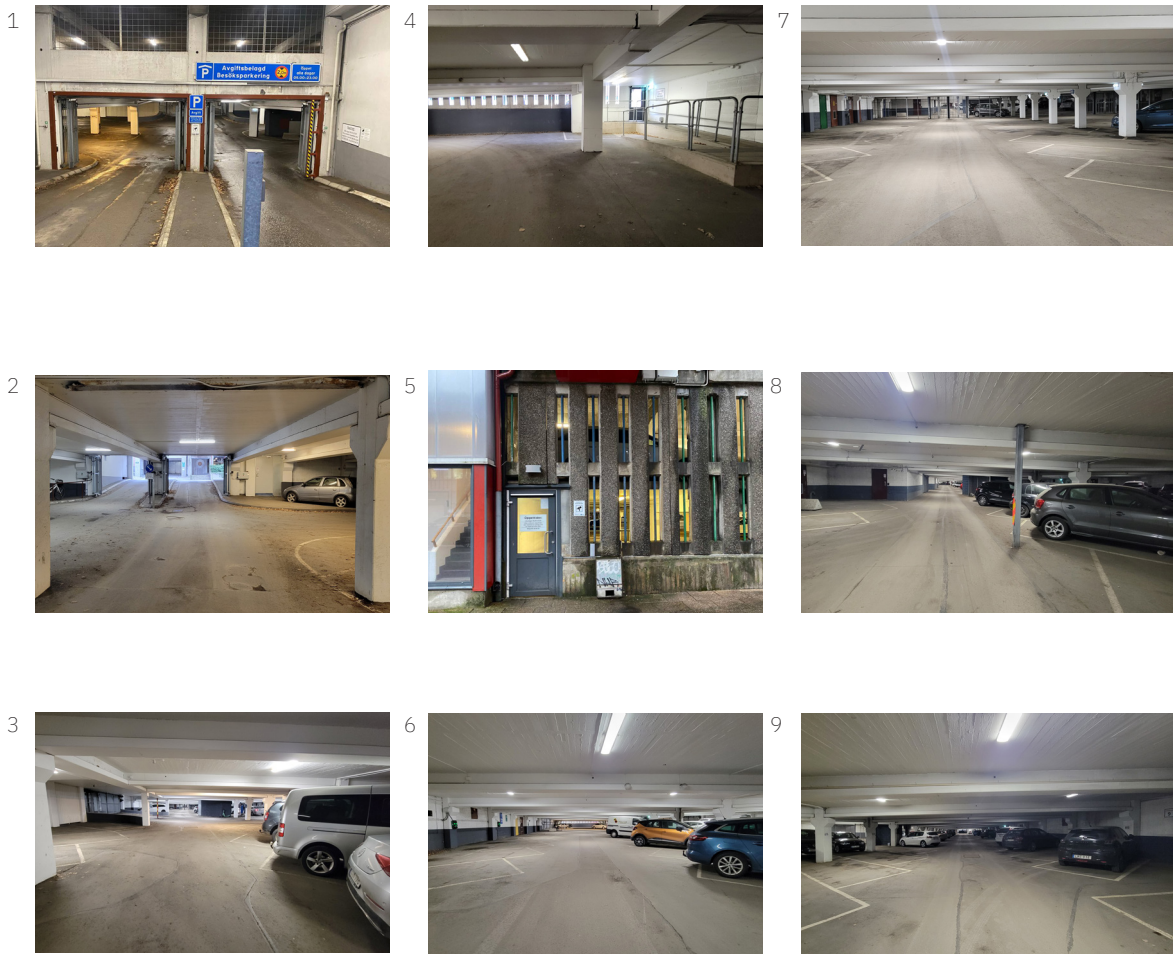
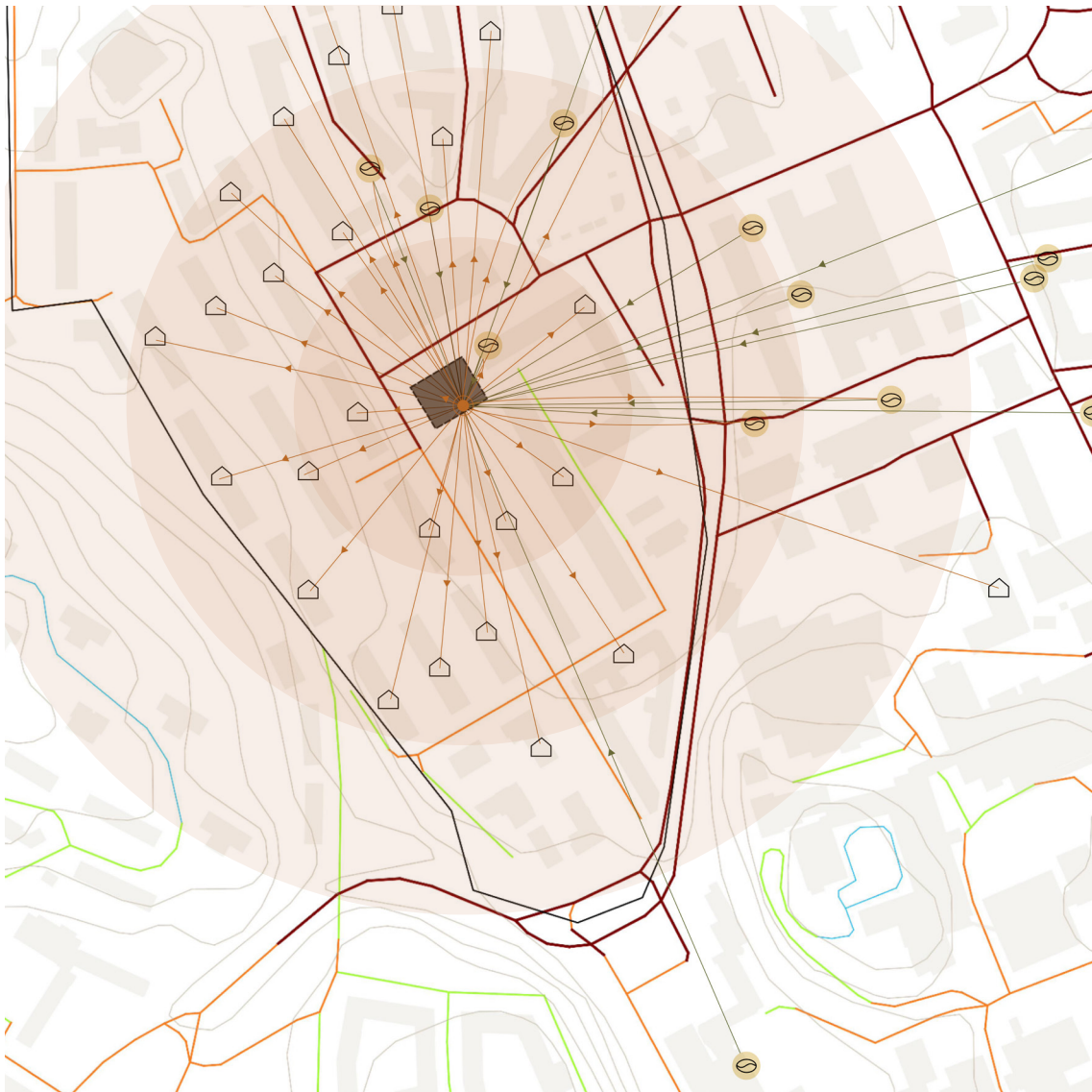
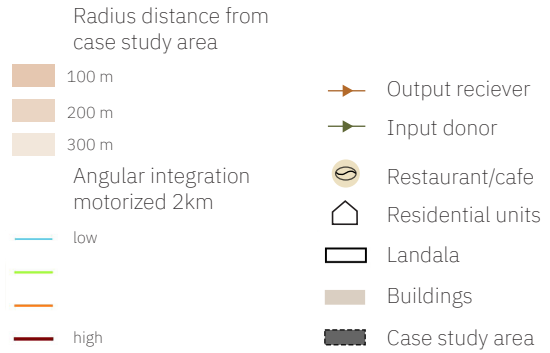

Fig 4.17. Landala parking garage scenes, the numbers are connected to locations on figure 5. (Own authorship)

4.3 Site Analysis

Resource mapping & Angular Integration

The resource map showcases the cafes and restaurants (donors) where the input product, coffee, is taken from, and the receivers, where the output product of the Mycelium Farm, food or other material, can be taken. We overlay angular integration with the resource sources to understand how easy is to access them based on how well-connected are the streets in the whole network (angular integration) and how far are these points from the case study area. (Fig. 4.18)



4.18 Resource mapping & angular integration of case study in Landala

1:2500

0m 250m





4.4 Design Phase
The involved stakeholders

**The involved stakeholders
in Landala Urban Mycelium Farm**

Civic participation and stakeholder involvement (self-governance) are core elements in the creation of Urban Mycelium Farms. In the Landala case study, we suggest a governance organization that combines bottom-up and top-down stakeholders along with the responsibilities and roles each of them plays in the planning of an Urban Mycelium Farm. (Fig.4.19) Later we speculated the stakeholder governance mapping on our specific site in Landala. (Fig.4.20)

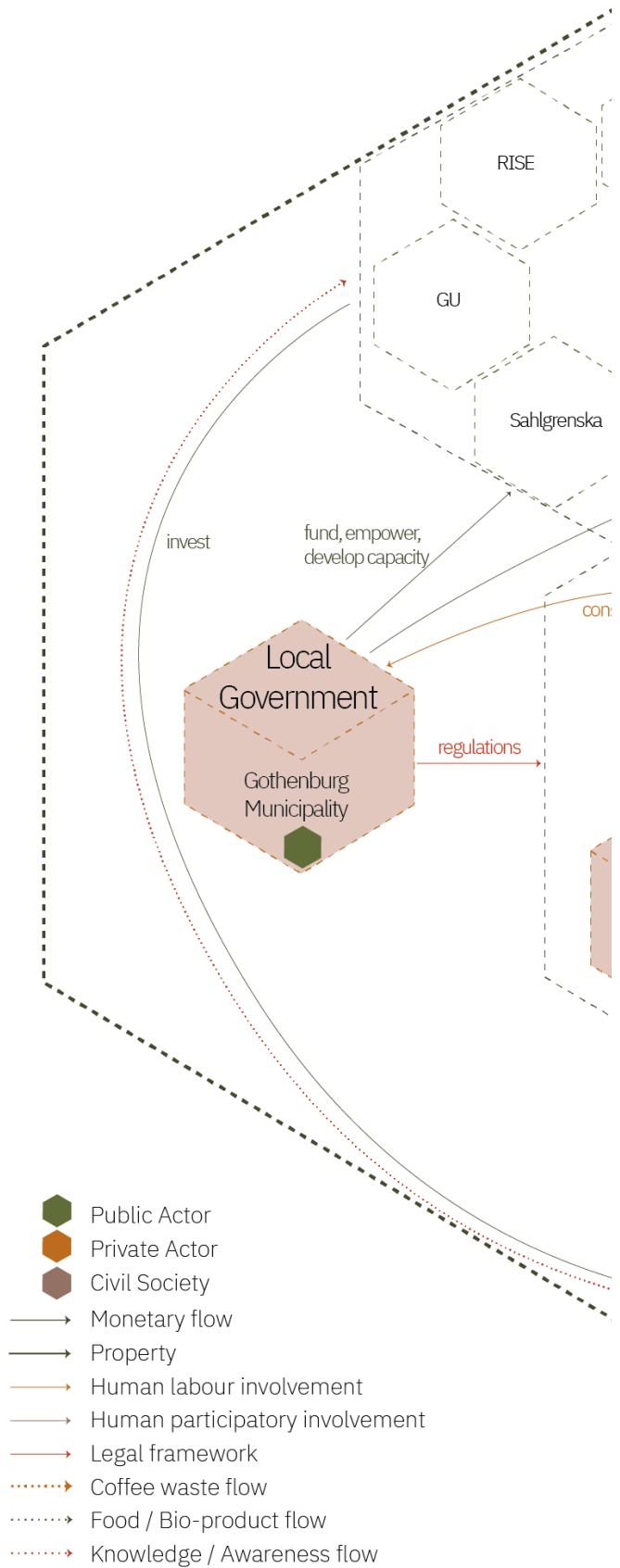

4.19 Landala Stakeholder mapping (own authorship)

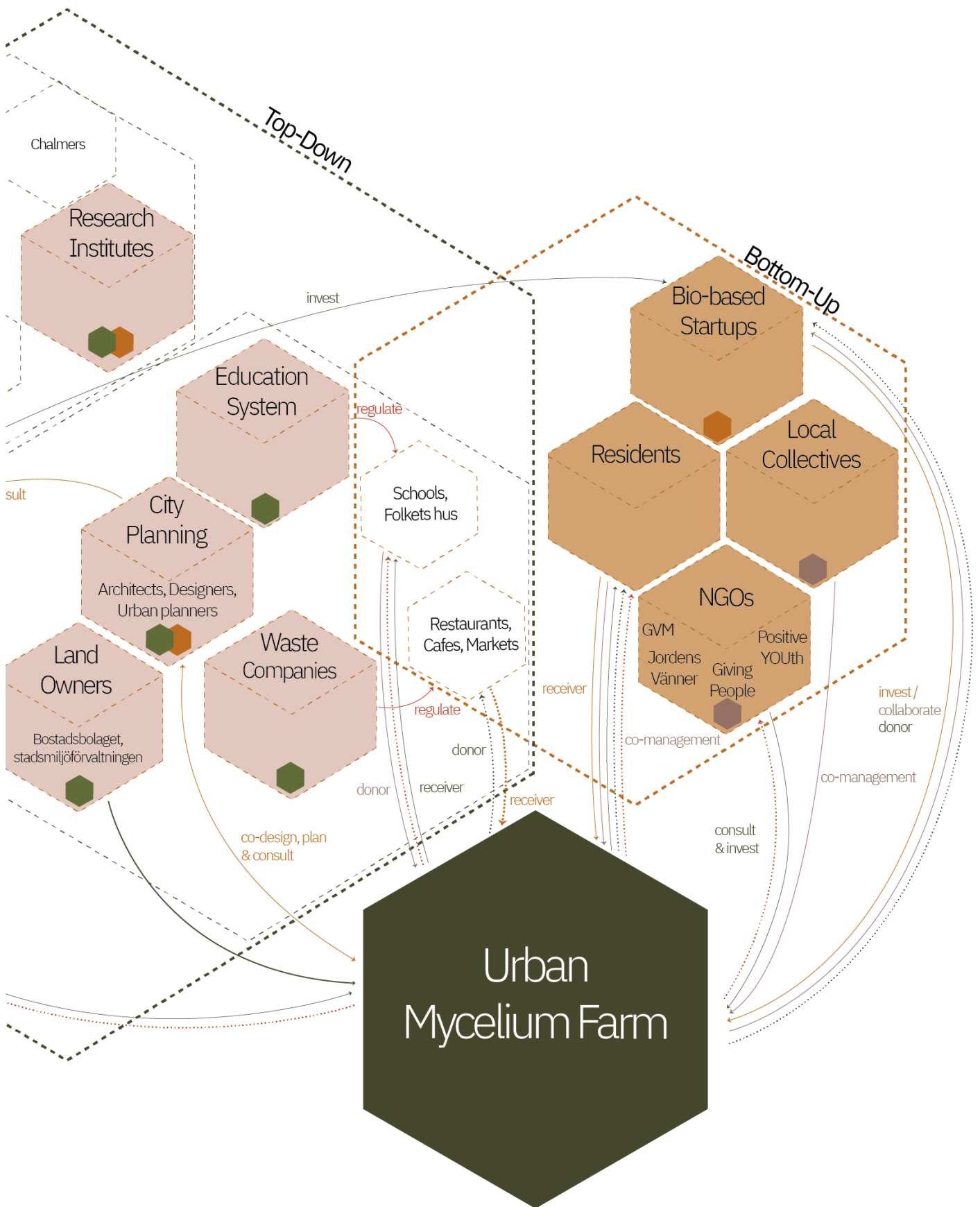

4.4 Design Phase Governance

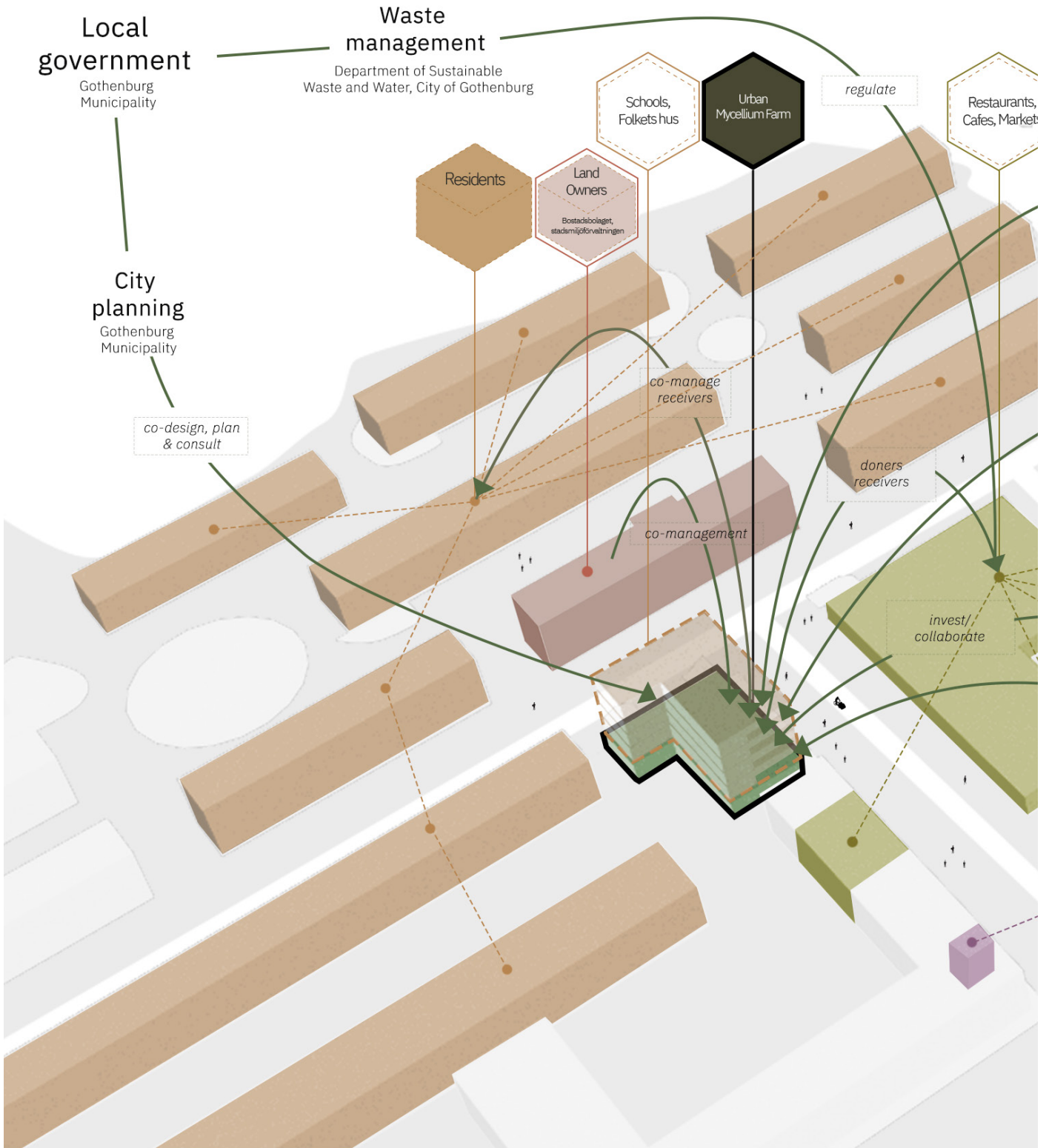

Fig.4.20 Landala Stakeholder mapping implementation on site (own authorship)

4.4 Design Phase

Stakeholder analysis & spatial conditions to grow mushrooms

Stakeholder analysis as precondition for engagement

Identifying stakeholders, understanding their utilization of the facilities, engaging them in the farm establishment process, and fostering a sense of commitment and ownership within the community, are vital for nurturing and sustaining the urban mycelium farm. Drawing insights from case studies, urban analyses, state-of-the-art, and interviews, seven key user categories were narrowed down. These encompass school children, educators, volunteers, researchers, local cafe and restaurant proprietors, cyclists, and product consumers. Not to forget these stakeholders can be part of the bigger Landala neighborhood community.

Our approach involves illustrating stakeholder relations through a comprehensive Stakeholder Relation to Activities and Spatial Categories graph. This visual tool connects stakeholders with spaces and potential activities, facilitating a nuanced understanding of their involvement. Moreover, we recognize stakeholders as not only participants but integral members of the community. Therefore, the potential relationships among them are mapped. It is important to note these connections of activities are not rigid; rather, they serve as a speculative exploration of possibilities, adaptable to evolving needs and dynamics.

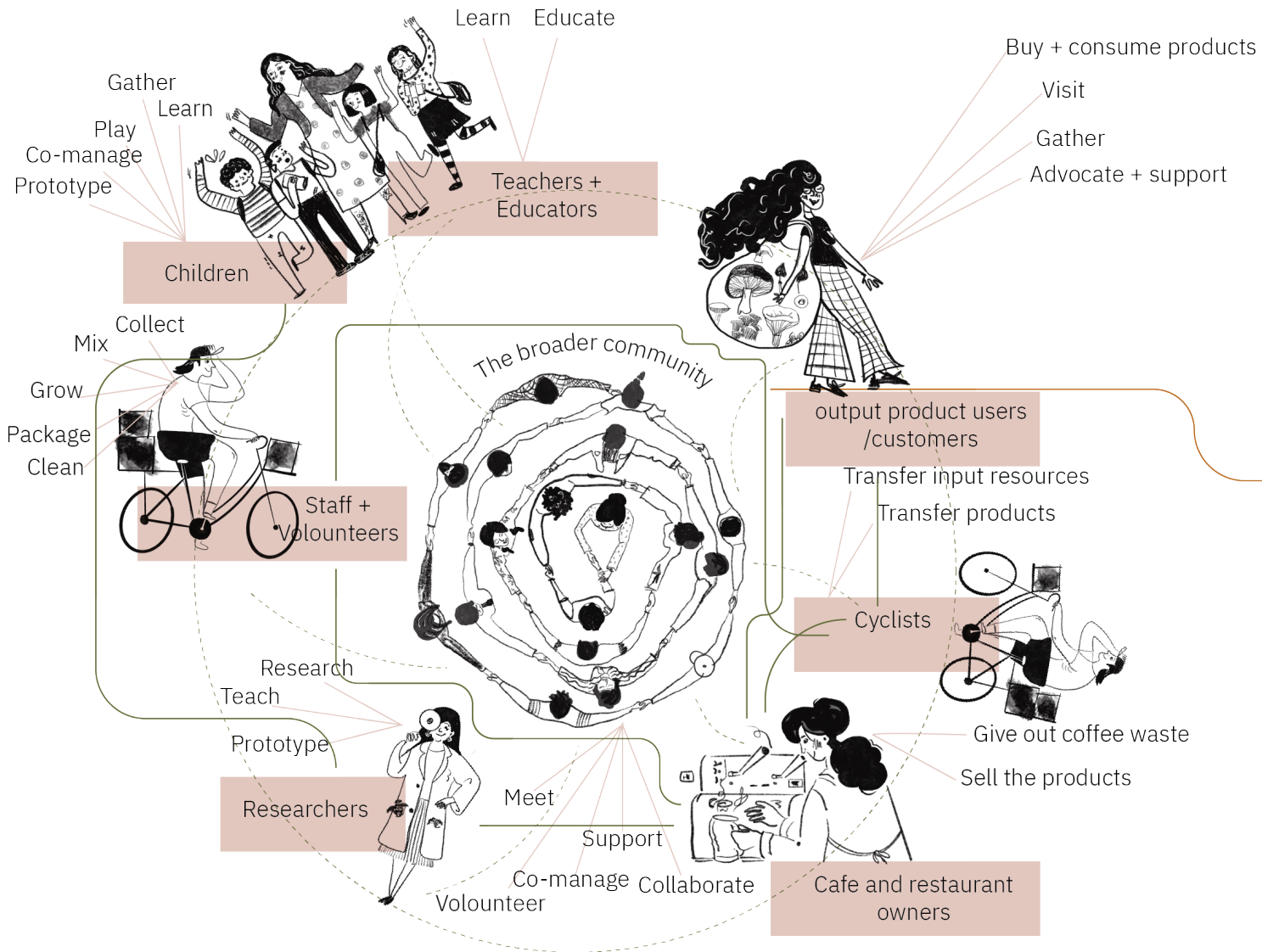

Figure 4.21 Identifying stakeholders and the relationship among them, (Own authorship)

4.4 Design Phase

Stakeholder analysis & spatial conditions to grow mushrooms

Spatial Conditions to Grow Mushrooms

Based on our visit to a mushroom farm in Denmark and findings from years of exploration into the easiest low-tech ways to cultivate mushrooms by Adam Sayner and Eric Jongshared, published on the GroCycle open resource, it is evident that most indoor spaces can be suitable for growing mushrooms. The only requirement is to dedicate space for all three main stages of mushroom growth:

Stage 1: Mixing & Inoculation – This is where the substrate ingredients and mushroom spawn are mixed and bagged.

Stage 2: Incubation – The grow bags are left in a warm, dark space for the spawn to grow throughout the bag.

Stage 3: Fruiting – The colonized bag is exposed to fresh air, humidity, and a little light, causing the mushrooms to ‘fruit.’

For the Mixing & Inoculation process, a compost tumbler and workbench are needed. For the Incubation process of oyster mushroom mycelium growing on coffee grounds, using shelves or hanging rails and controlling the temperature around °24 – 20C is the most efficient. Therefore, having an insulated space will keep energy usage to a minimum. For the Fruiting stage, an easy-to-clean, controlled area to minimize contaminants like mold, with high humidity, is optimal. Setting up the fruiting chamber on a concrete floor with a nearby drain is highly recommended, as dampness can ruin wood, drywall, carpet, and most other common building materials over time. Landala Parkings existing flooring is ideal for the fruiting process. Additionally, an exhaust pipe to flow air out of the fruiting chamber and bring in fresh air is another requirement that can be easily addressed when the chamber is located next to existing parking windows (Sayner & Jongshared, 2023).

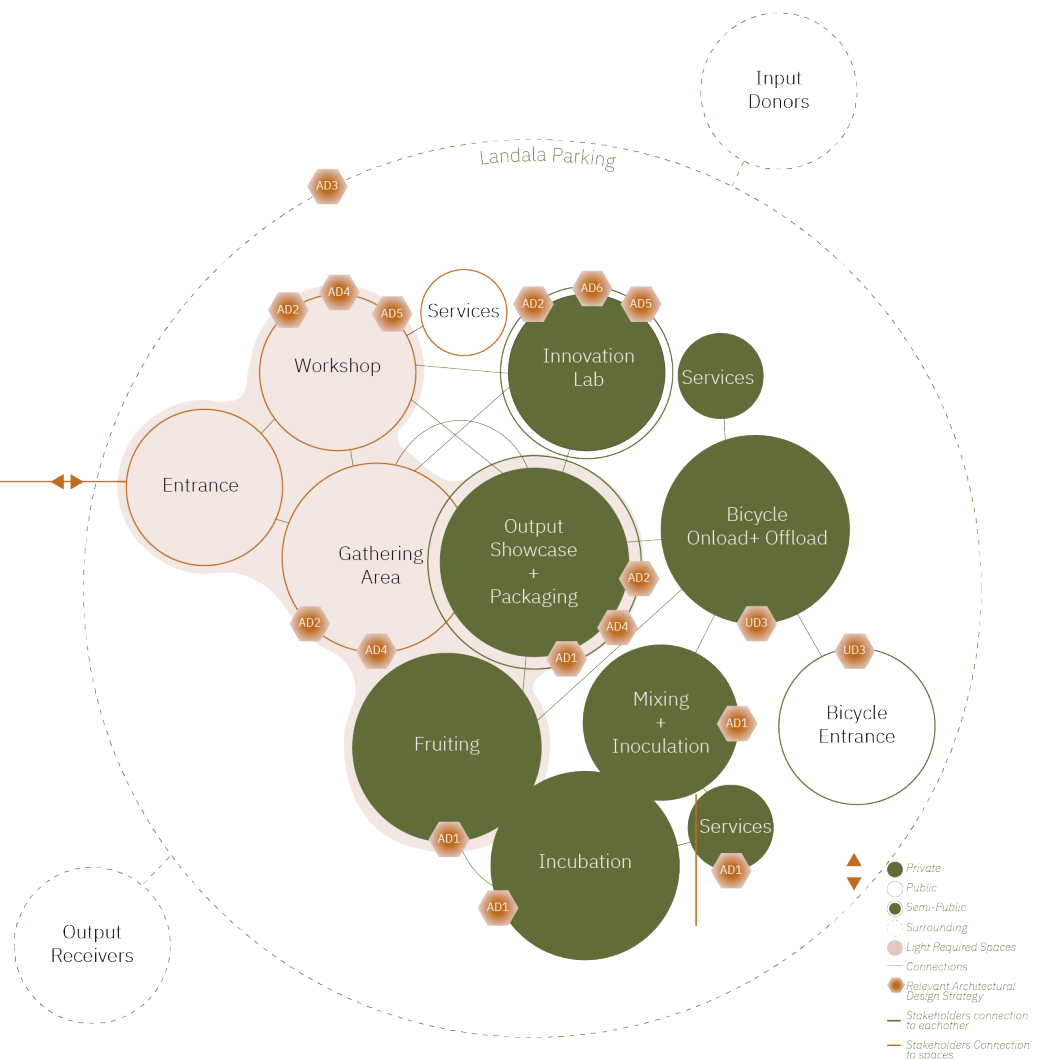

Figure 4.22 Bubble diagram of spaces of Landala Urban Mycelium Farm (Own authorship)

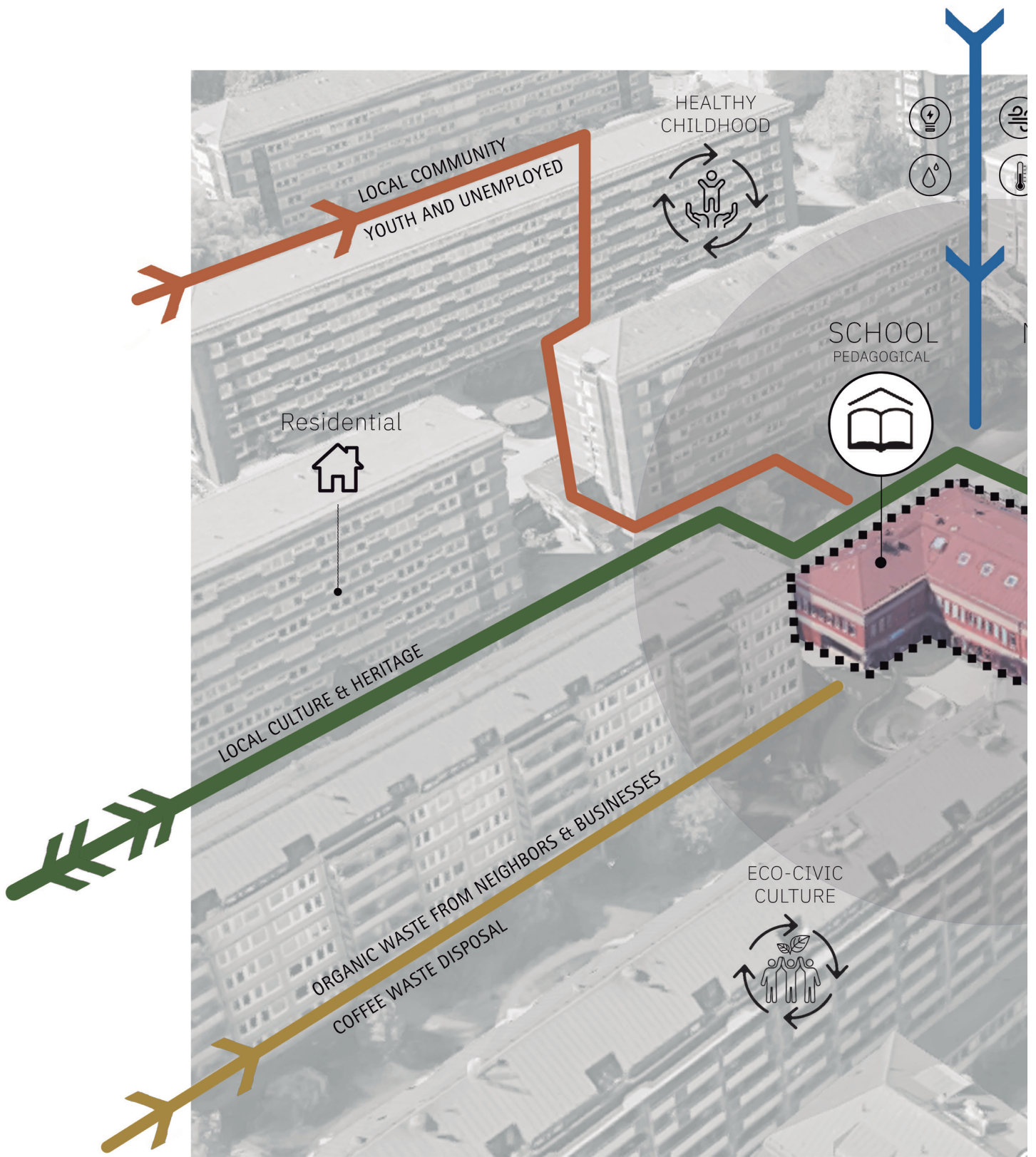
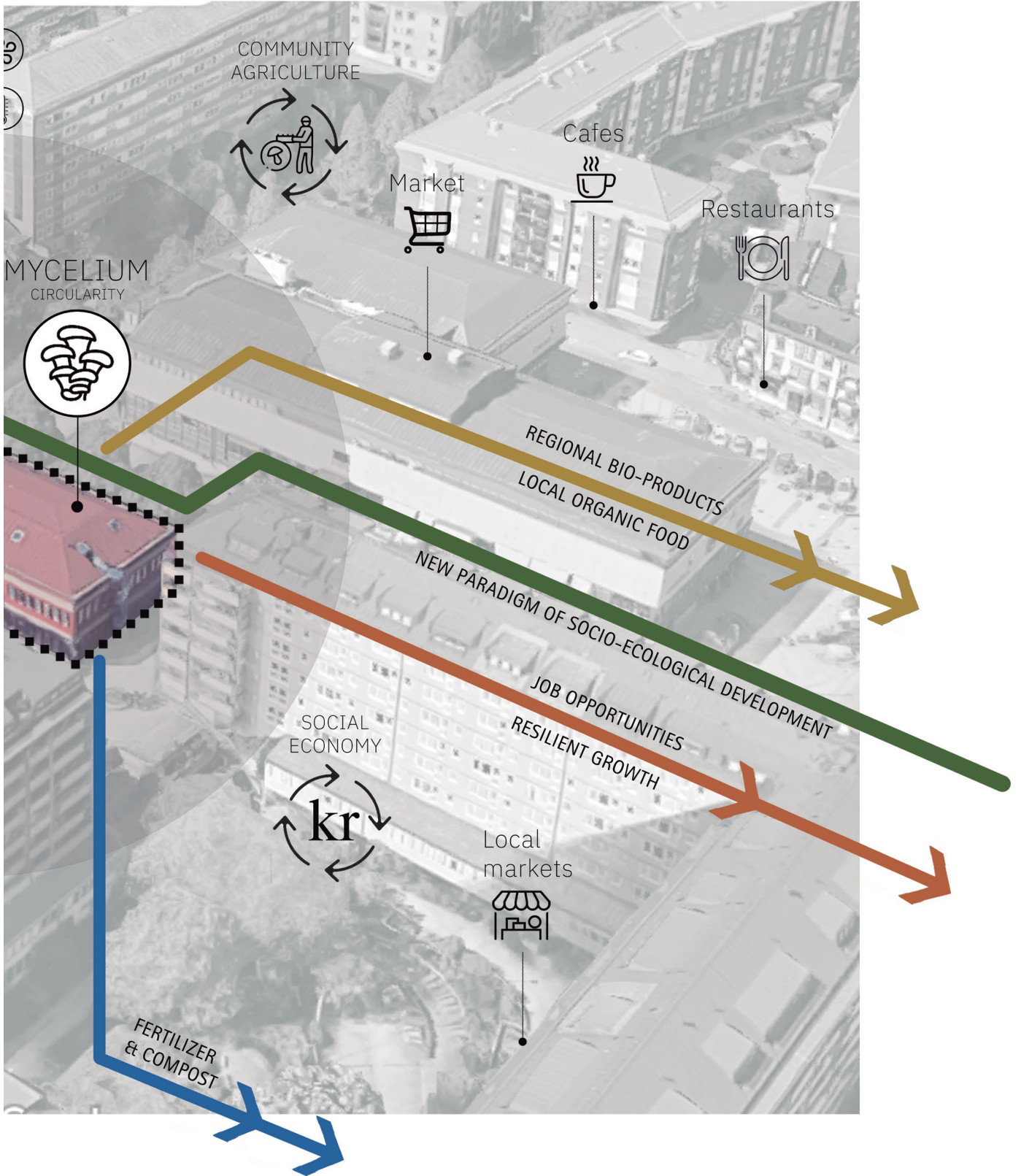

Figure 4.23. Local effects envisioned: contextual inputs & outputs. (Own authorship)



4.4 Design Phase

Design strategies to transform the public space and interior of the building

Landala Mycelium Farm as Public Space

Landala Mycelium Urban Farm is aimed to be a social cooperative based on three main types; educational, sustainable food production, and awareness making. The educational objective involves schools, youth, and children, and raising awareness on the neighborhood scale by incentivizing locals and passers-by to participate.

To achieve this, there is a need to transform the current Landala parking lot into a public space that is not only inviting to the community but also safe and conducive to fostering pupil's learning goals creatively. We use the below five design strategies to come up with the best solutions for this transformation.

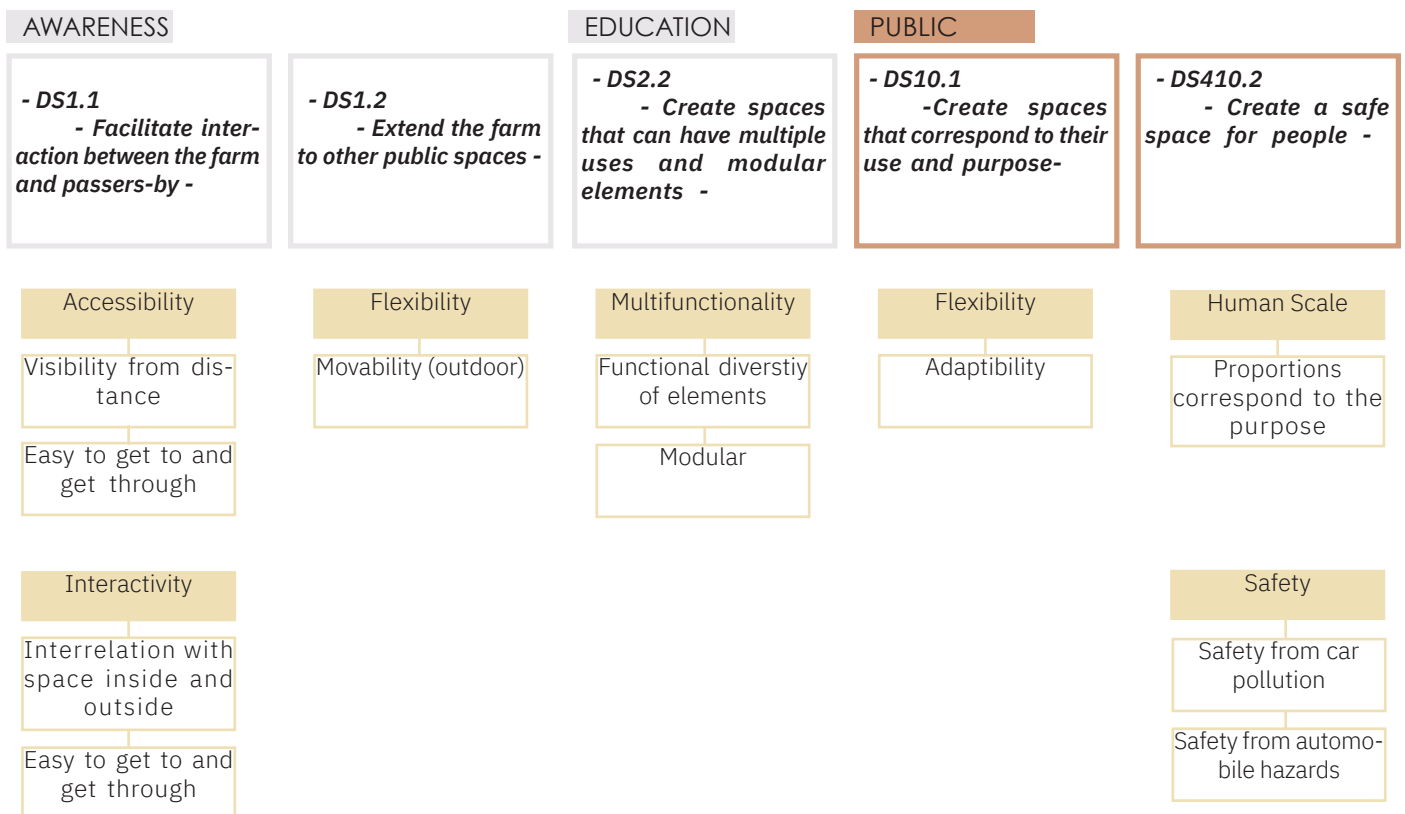

Additionally, to better implement our design strategies into spatial realization, we made a graph of what we will do to implement the design strategies.

This graph is inspired by Ludmila Kozlova and Valery Kozlov's analysis of ten quality criteria of public spaces in a large city (Kozlova & Kazlov, 2018).

4.4 Design Phase

Design strategies to transform the public space and interior of the building

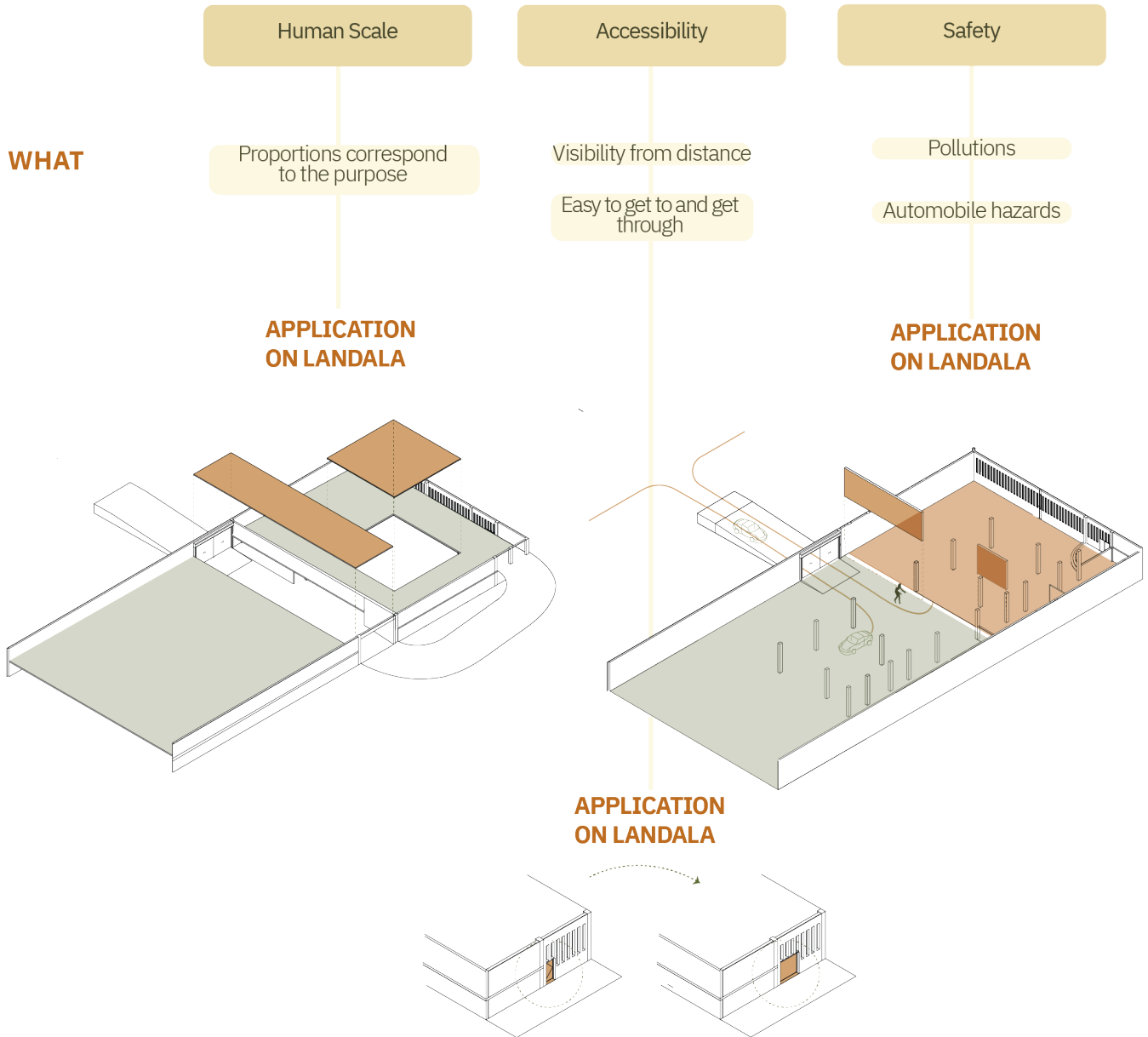

HOW To optimize Landala's two-story parking structure for use as a public space, adjustments are made to the 2.5-meter height of the parking. Specifically, two sections of the second floor are removed, creating open voids within the structure, and fostering a more inviting and adaptable environment for public activities.

HOW Widening the pedestrian entrance door from Amund Grefwegatan, at the north-eastern side of the site.

HOW The site will be partially working as a parking lot. To ensure the safety of users specifically children, a clear separation between the mycelium farm and the area designated for vehicles is established.

4.4 Design Phase

Design strategies to transform the public space and interior of the building

Multifunctionality, interactivity, and flexibility are integrated through the creation of building elements within the existing Urban Mycelium farms. Each of these elements fulfills all 3 criteria and influences the internal spaces, the relationship with users, and in instances involving movable outdoor elements, the relationship with surrounding public spaces.

While the functions of these elements are explained within these pages, it's essential to note that their dimensions must be adjusted according to the specific requirements of each site.

WHAT

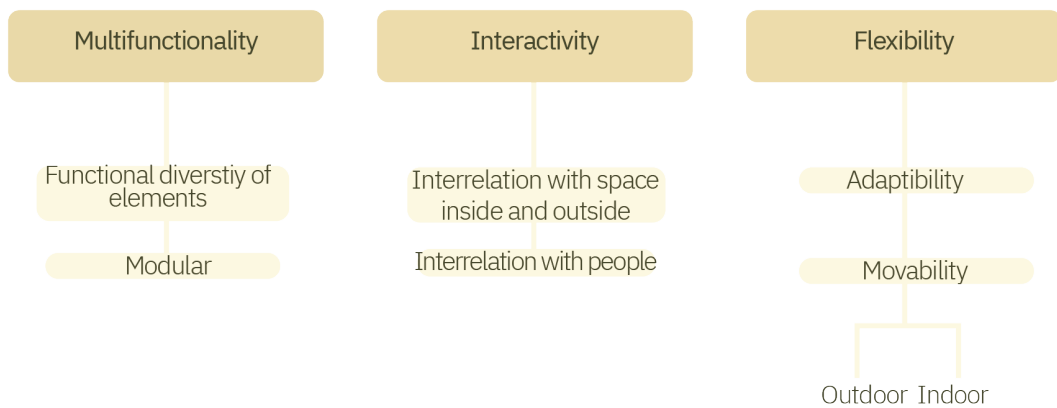

APPLICATION ON LANDALA

Movable, Modular Multifunctional unfoldable shelves, used as walls

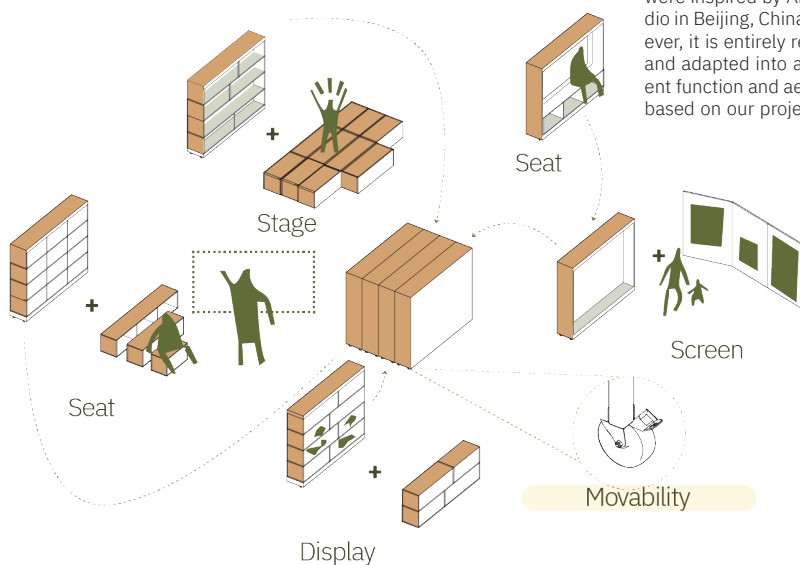

HOW Movable unfoldable shelves located in front of fixed walls of the farm, when unfolded, provide functional elements such as a display for products, seats, stage, and screen. The different functions provide maximum adaptability for various needs. These shelves take minimum space can be connected due to modularity and are easily movable due to the attached wheels.

APPLICATION ON LANDALA

Movable, cultivation and packaging shelves and tables

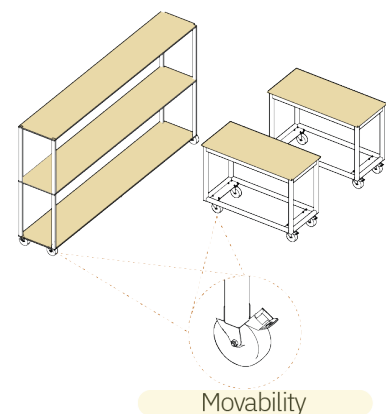

HOW Based on the site visit to BYGAARD's organic mushroom farm, it's evident that regular cleaning is of paramount importance within the Urban Mycelium Farm. As a result, all elements, particularly those utilized for cultivation, must be equipped with wheels for ease of movement and cleaning.

4.4 Design Phase

Design strategies to transform the public space and interior of the building

APPLICATION ON LANDALA

Movable wagon, located ground floor, next to entrance.

On days with good weather it is taken to the open public spaces.

NOTE to FUTURE DESIGNER Especially with projects dealing with the transformation of underground spaces, such as parking lots, it is necessary to consider potential height constraints. In some cases, ceilings may be as low as 2 meters, posing challenges for taller vehicles like wagons.

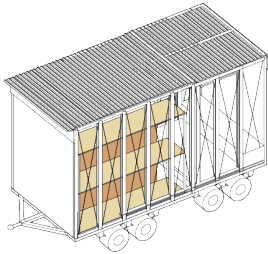

Closed Wagon

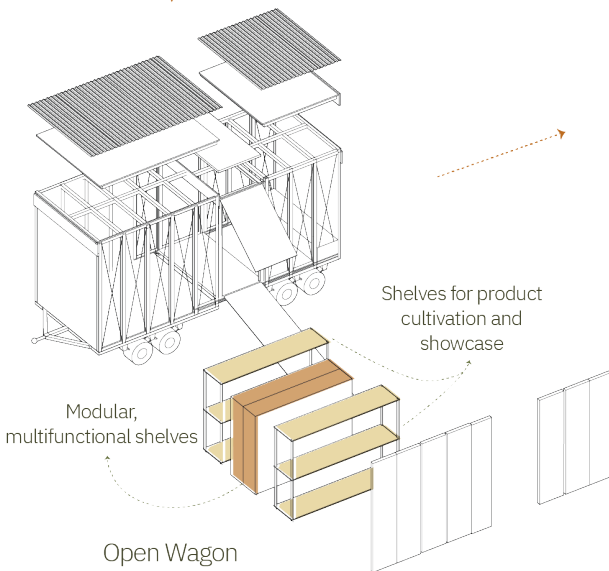

Open Wagon

This wagon was inspired by Meal Distribution Center designed by Marianna Fujii. However, it is entirely re-drawn and adapted into a different function and aesthetic based on our project.

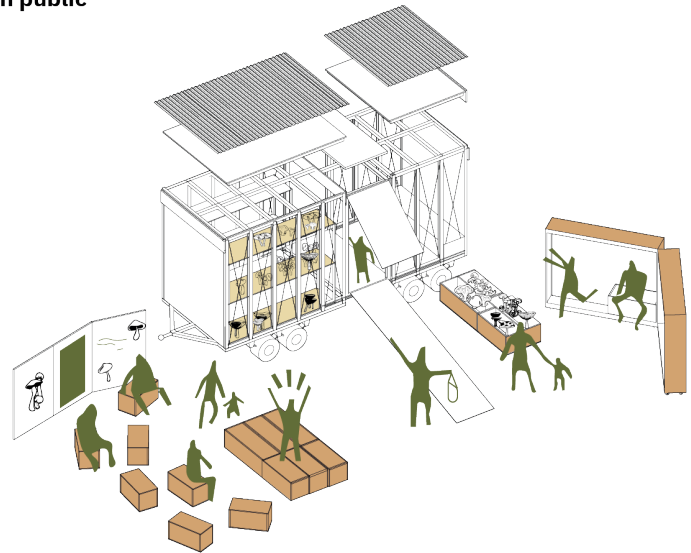

HOW An opening and closing wagon that encompasses two shelves, and two modular walls, when open during days with good weather it can be taken to the surrounding public spaces, strengthening the connection with other public spaces in the neighborhood, conducting workshops, showcasing and selling products, and raising awareness on places other than the farm itself.

In colder weather, it will be in the urban mycelium farm used as a storage or extra cultivation container.

APPLICATION ON LANDALA

Walls connecting the cultivation to the public

HOW Some of the walls to the cultivation zone can be opened and closed enhancing visibility and interaction with the public. These doors are not used by staff for cleaning, for cleaning purposes, it is better to use «roller shutters» or «roll-up doors», which have horizontal slats that roll up and down vertically.

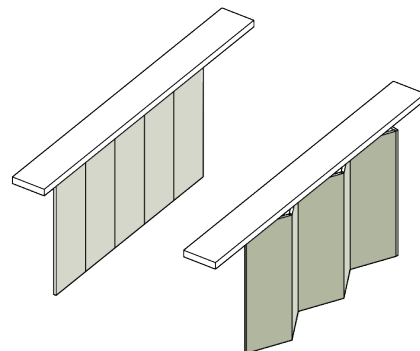

Takeaways

Ensuring that an underground space is inviting and practical for public use is a pivotal aspect of the design process. To achieve this, factors such as human scale, accessibility, safety, multifunctionality, interactivity, and flexibility must be thoroughly analyzed and tailored to the characteristics of each project.

These adjustments may involve interventions in the building's facade and structure or the design and insertion of spatial elements. Each modification contributes to transforming the atmosphere, enhancing multifunctionality, increasing dynamism, and fostering a sense of belonging and eagerness for engagement.

4.4 Design Phase

Landala Urban Mycelium Farm Designing Within a Parking Lot

Landala Urban Mycelium Farm Designing Within a Parking Lot

As a reaction to the design strategies and the design process steps (spatial conditions to be a public space, stakeholder speculation, spatial conditions to grow mushrooms, and The relationship between stakeholders and the spaces graph), the Landala parking lot was transformed partially. into an Urban Mycelium Farm

The southern section of the parking lot remains as parking for cars. This decision comes from the belief that a gradual transition to sustainability cannot happen at once. Current city life city relies on cars, and eliminating parking spaces would threaten the sustainability of the farm. Therefore, we are gradually reducing parking spaces with the vision that in the future, cars will no longer be necessary, and the parking lots will be repurposed (figure 4.24).

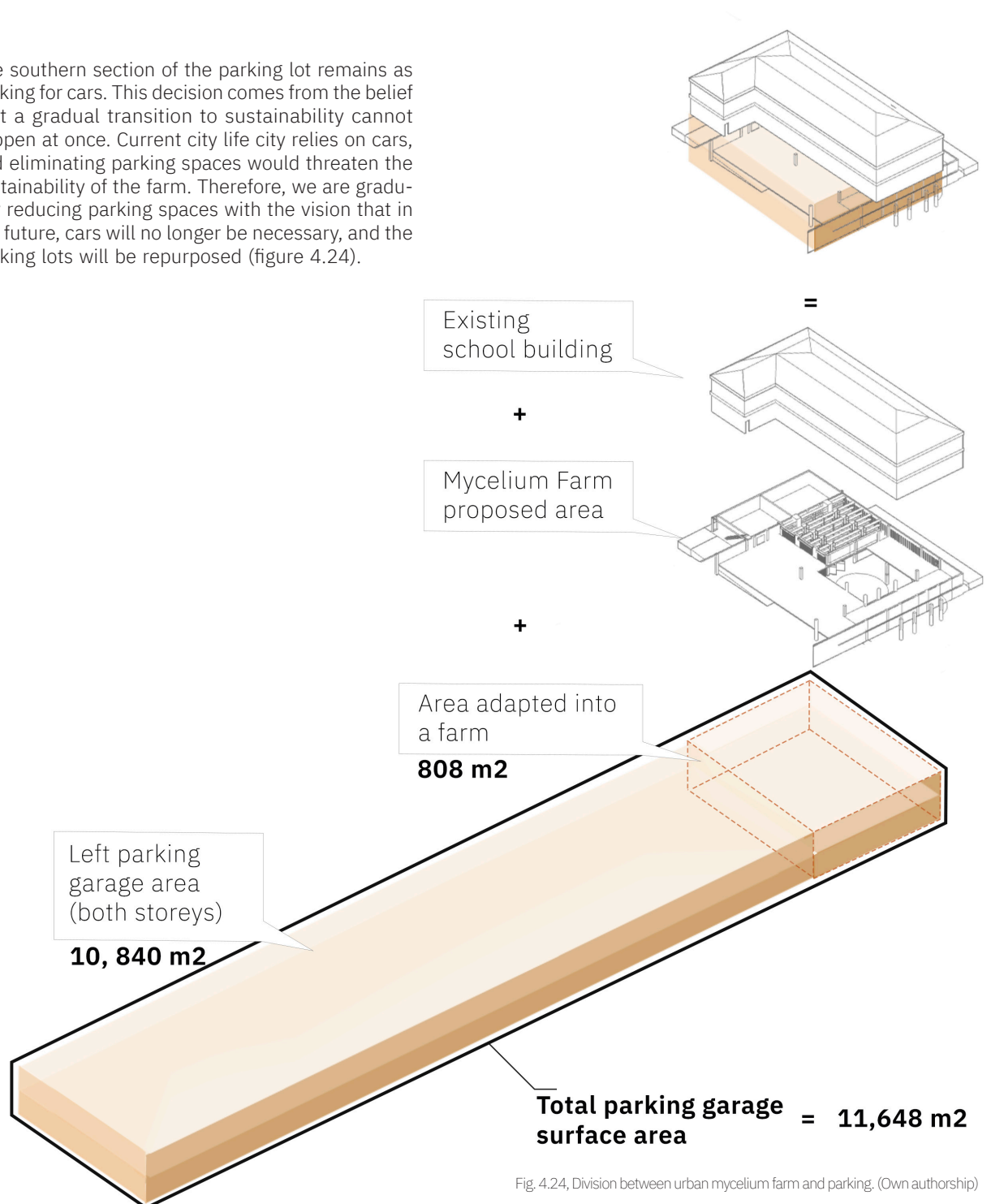

Fig. 4.24, Division between urban mycelium farm and parking. (Own authorship)

4.4 Design Phase

Landala Urban Mycelium Farm Designing Within a Parking Lot

The northern part of the parking lot is the most suitable location for the Urban Mycelium Farm for five reasons (Fig. 4.27):

Accessibility: Even though the space is divided into two functions, an urban mycelium farm and a parking lot, both still have access to the main vehicle entrance and ramps leading to the second floor.

Proximity to Stakeholders: The location has direct access to Franska Skolan Primary School, a key stakeholder identified in the project.

Convenience: It is in close proximity to Kapellplatsen, public transport access points, as well as various cafes and restaurants.

Light Resources: The northern part already has openings into the street, that provide light for cultivation and public area functions.

Visibility: Better visibility for the farm increases public engagement



Fig 4.25. Landala Parking location. (Own Authorship)

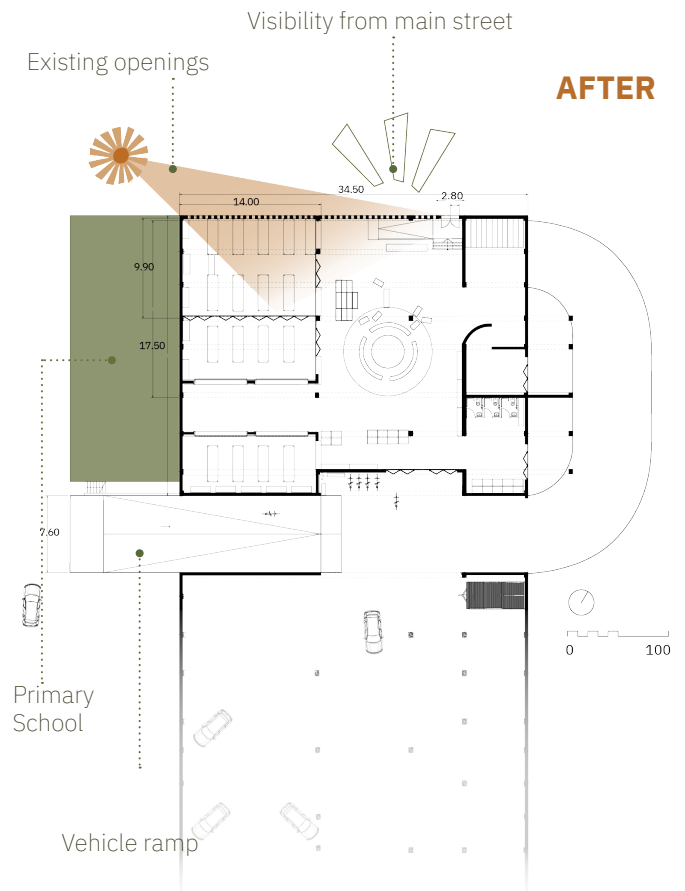
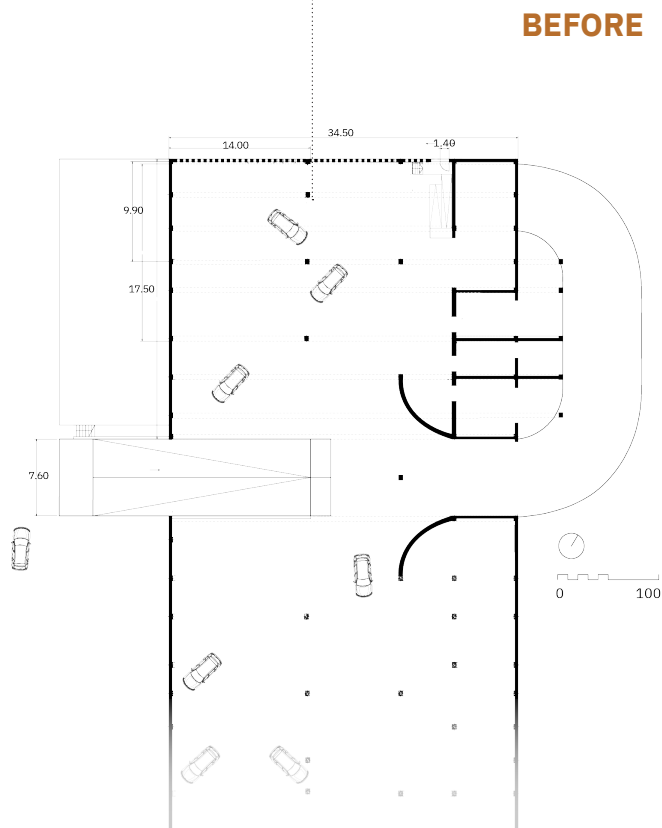

Fig. 4.26, Current Landala Parking, ground floor plan based on architectural survey (Own authorship)

Figure 4.27, Showing accessibility, visibility, light resources, and proximity to stakeholders of Landala Urban Mycelium Farm (Own authorship)

4.4 Design Phase

Landala Urban Mycelium Farm Plan Zoning

Landala Urban Mycelium Farm Plan Zoning

Based on the spatial bubble diagram of the previous page, there are 3 main zones in Landala Urban Farm:

1- Publicly Accessible Zone

Gathering Area, Workshop space

2-Privately Accessible Zone

Mixing and Inoculation, Incubation, Storage

3- Semi-Public zone

Innovation Lab (Prototyping space), Packaging and showcase area

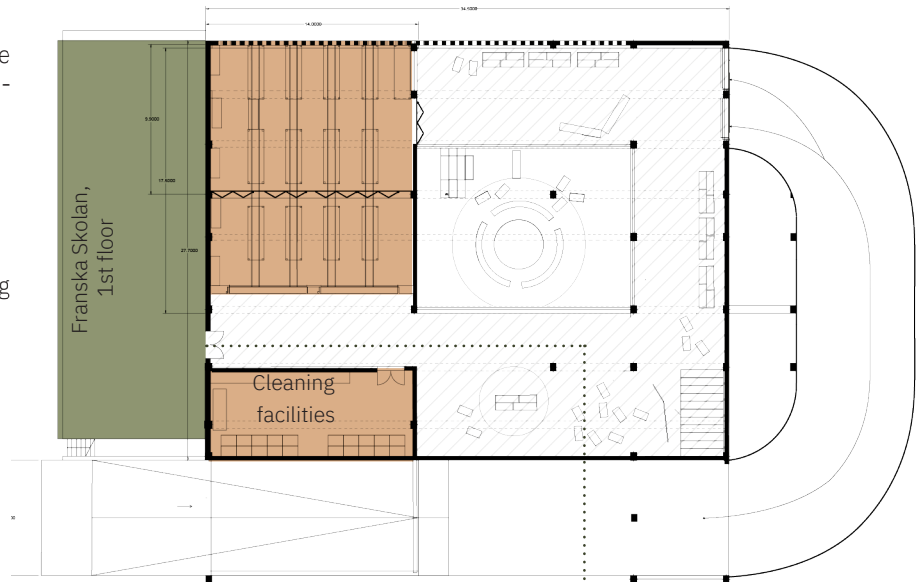

Fig. 4.29, Landala Urban Mycelium Farm first floor plan, scale 1:500 (Own Autorship)

Adding a direct entrance between the Landal Urban Mycelieum Farm and the Franska Skolan primary school.

The first floor is equipped with additional facilities for various purposes, including cultivation, cleaning, and showcasing products. Specifically, this space is designed to facilitate interactive workshops, particularly aimed at engaging primary school children. These amenities support hands-on learning experiences.

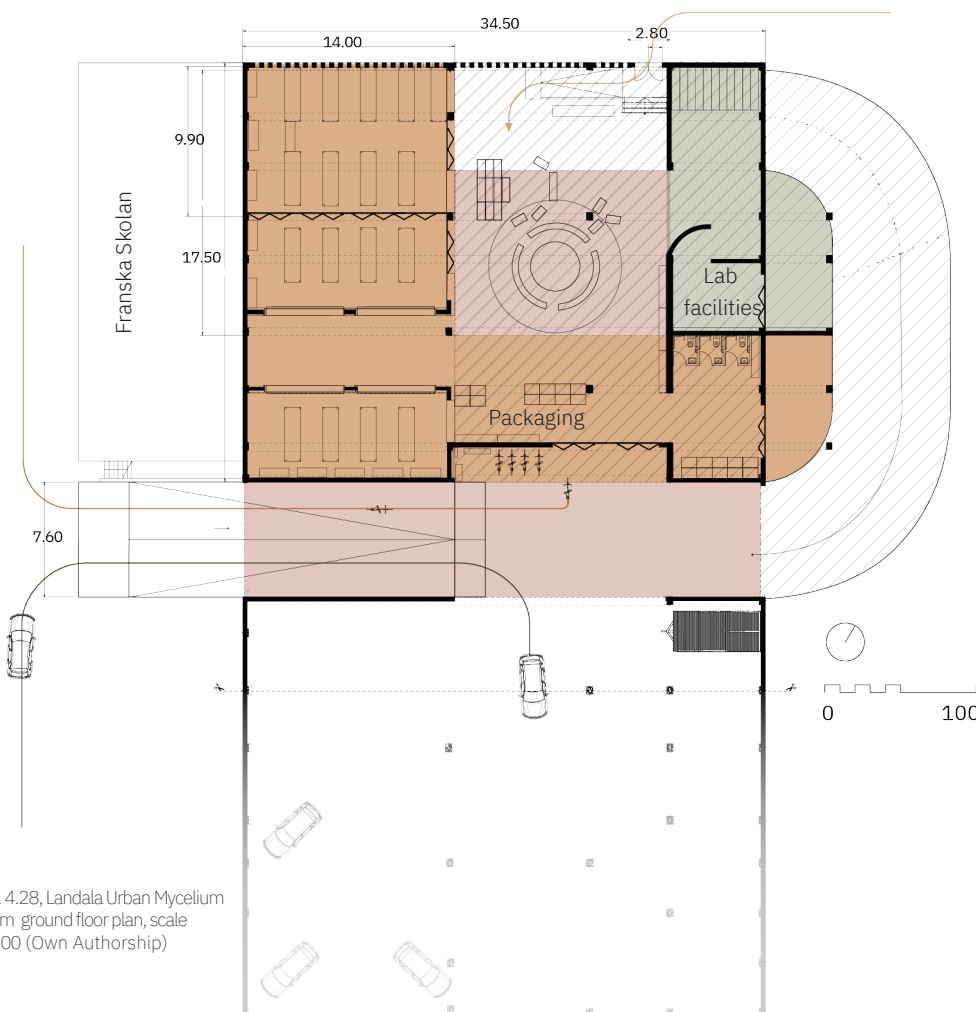

Fig. 4.28, Landala Urban Mycelium Farm ground floor plan, scale 1:500 (Own Authorship)

4.4 Design Phase

Experimenting the spaces through collages

Experimenting the spaces through collages

The spaces and their functions are explored through a series of collages. These explorations show how the Urban Mycelium Farm can accommodate various activities, promote engagement, and provide a learning platform for different groups of the community.

The later collages were adapted to the specific transformation we conducted based on our strategies, zonings, and the added elements on users and the encounters they create.

The first collage (fig. 4.30) which is more abstract acts as a creative brainstorming of space and activities, setting the ground to better realize the spatial needs and get a more thorough understanding of the steps required in the design process.



Fig. 4.30 First collage, sketching on top of a photo taken from Landala Parking, with the help of Dale generator (Own Authorship)

Collage 1:

-Changing the image of the parking to an inviting place
- Imagining a space for cultivation next to the existence of humans

-Sketching different activities into the current space
- Better realizing the scale of space

4.4 Design Phase

Experimenting spaces through collages

Experimenting spaces through collages

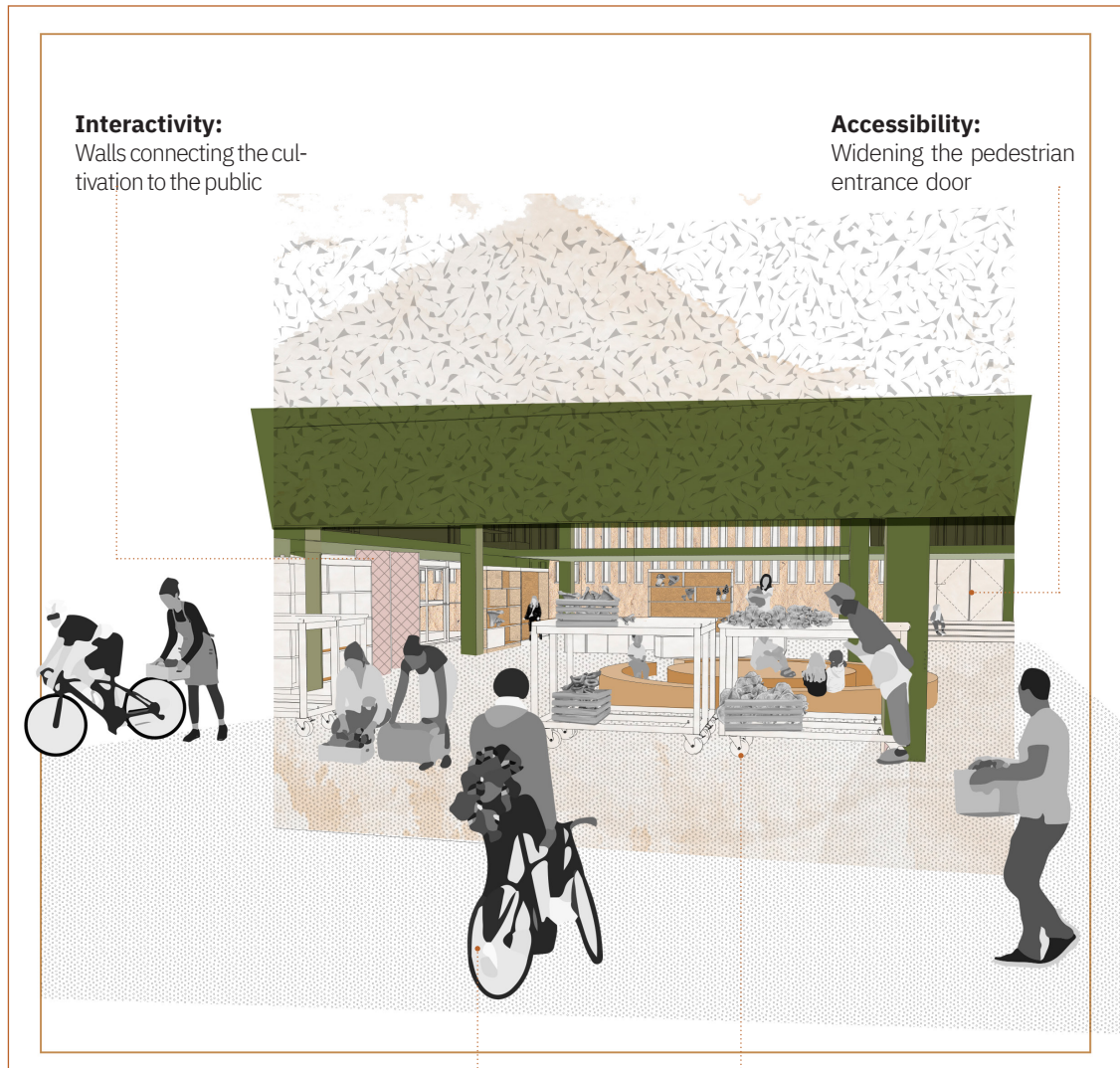

Figure 4.31 Collage 2, (Own Authorship)

Safety:

Packaging and selling come between the gathering area and bicycle waiting

Flexibility:

Movable shelves and table due to wheels

Collage 2: Packaging and purchasing

- Packaging shelves are the zone between the public and private, where the staff package the products and prepare them for delivery.
- Input resources from coffee shops and restaurants are brought in as well from this entrance
- The packaging area creates a physical and visual division between the transport zone and the public zone

- The public can directly view the products on the shelves and pick and purchase them
- As marked on the collage, some of the spatial conditions are tested

4.4 Design Phase

Experimenting spaces through collages

Experimenting spaces through collages

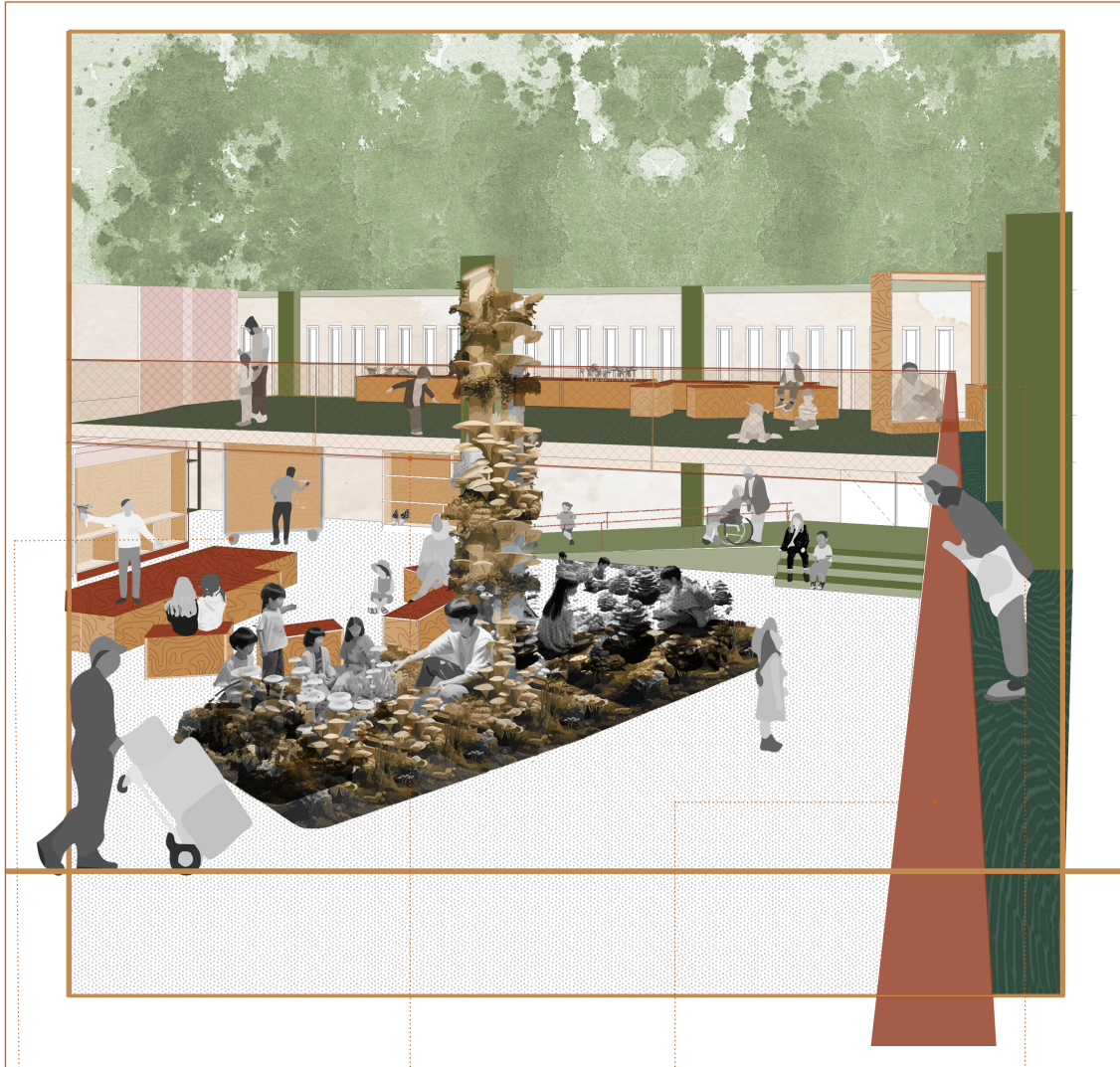

Figure 4.32 Collage 3, (Own Authorship)

Flexibility:

Movable shelves and table due to wheels

Human Scale:

Increasing the height of the public zone by creating voids.

Accessibility:

Creating co-presence with the void, the ground floor and 1st floor are sharing one space without the obligation for direct interaction.

Multifunctionality, Interactivity, Flexibility:

Movable unfoldable shelves

Collage 3: Public Area

-The open void creates not only sufficient height but also a sense of co-presence for users and staff working on the ground floor and first floor.

-Movable unfoldable shelves can be used throughout the whole farm, as a stage, seat, display, and screen. Allowing the users to adapt them to their needs.

4.4 Design Phase

Experimenting the spaces through collages

Experimenting spaces through collages

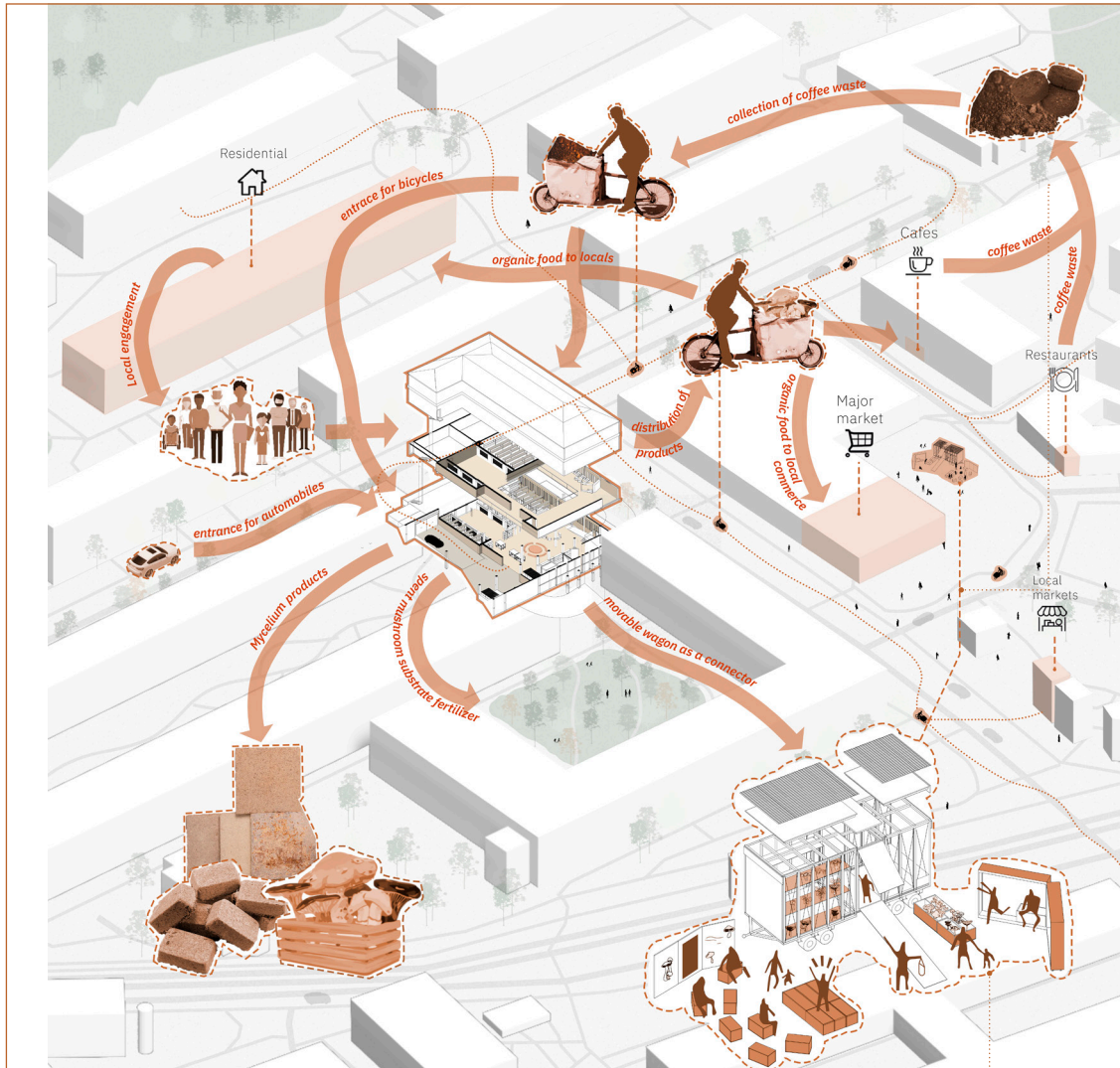

Figure 4.33. Input, and output flows of goods and services in relation to the neighborhood (Own Authorship)

Multifunctionality, Interactivity, Flexibility:
Movable wagon, Movable shelves

Collage 4: Input, and output flows of goods and services in relation to the neighborhood

- Showcasing how coffee waste from restaurants and cafes is brought into the farm, and the output products are sent out to the receivers using bicycles. (Specific spatial requirement: High proximity to markets, restaurants, shops & single customers)

- The Movable wagon creates a connection between

the farm and its surroundings, strengthening education and awareness roles of the farm while introducing, showcasing, and selling the products (Specific spatial requirement: Space for showing the relationship between fungi and local culture, Proximity to public gathering spaces).

- Having a proper cycling infrastructure plays an important role in the function of urban mycelium farms (Generic spatial requirements: Access to cycling infrastructure).

4.4 Design Phase

Experimenting spaces through collages

Experimenting spaces through collages

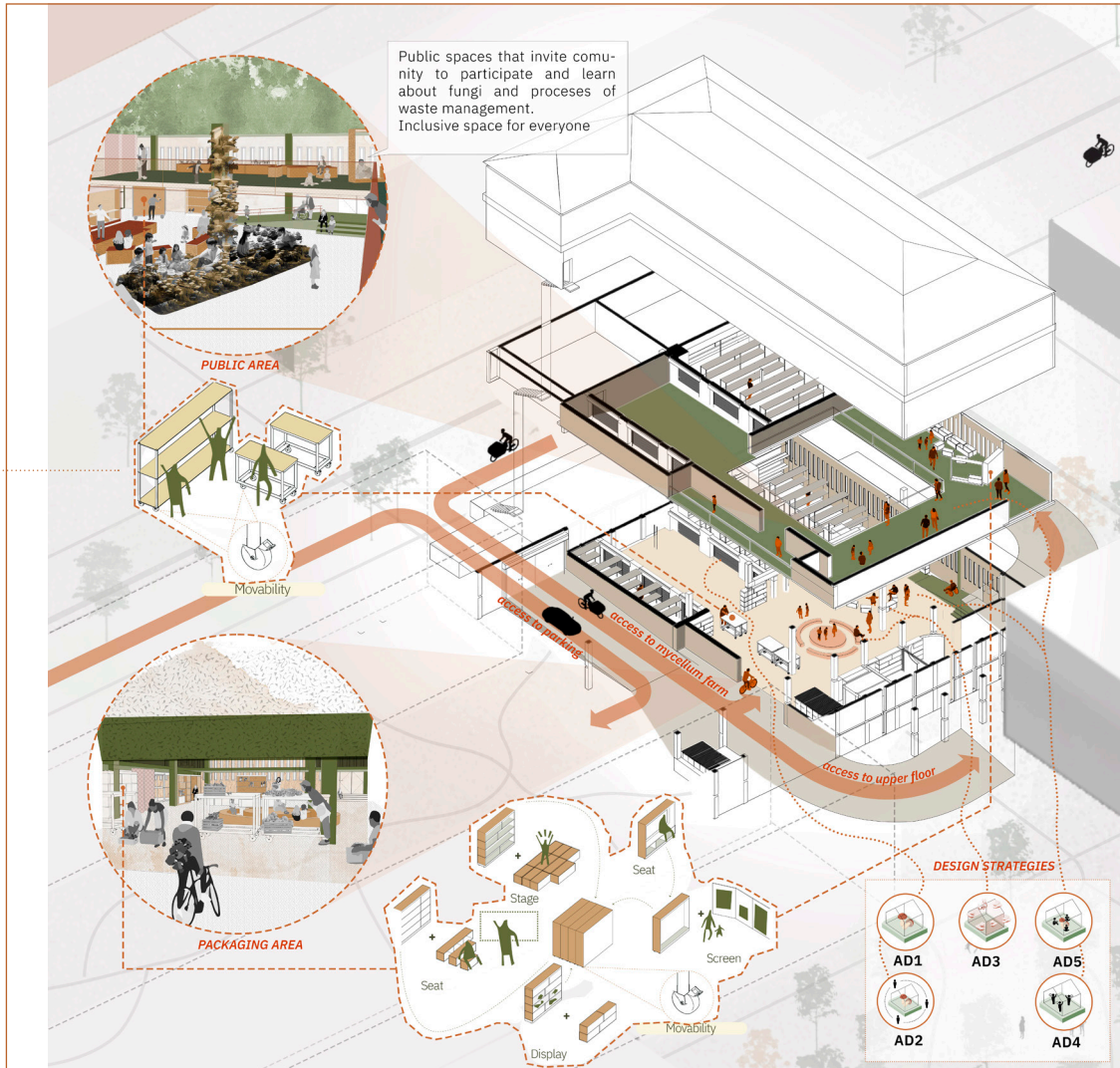

Figure (4.34) Collage 5. Isometric Mycelium Farm, spaces, design strategies applied and movable equipment (Own Authorship)

Multifunctionality, Interactivity, Flexibility:
Movable-unfoldable shelves

All architectural Design Strategies used in the farm.

Collage 5: Isometric Mycelium Farm

The final collage shows the activities happening on both floors of the farm in relation to each other.

The building vehicle entrance is divided into two, one for cars going to the parking and one for bicycles entering and exiting the farm.

Ground floor used for growing, packaging, research, and public gathering.

The first floor is used for growing, showcasing, storing, and due to the direct access to school, education specific for school children.



5.1 Conclusions & Reflections

Outlook

The overall aim of the thesis has been to develop the concept of an Urban Mycelium Farm, its spatial requirements, and corresponding design strategies to enhance its impact. The research not only showed us that the concept of an Urban Mycelium Farm as we propose is feasible, moreover, it also prepared the ground to further extend its reach and explore all the different types of farms we defined in multiple locations.

Based on the reference projects and concept investigation, we conclude that if properly structured and planned, any city could benefit from the implementation of Urban Mycelium Farms, adapted to its contexts and urban environments. The function of fungi is to decompose and transform material, and most of the waste material we produce that we can not recycle or reuse, fungi can do, creating new products and reincorporate them again into existing lines of production.

In our particular case study, we selected one type of waste material: coffee waste. As substrate for growing certain species of fungi is ideal, containing essential elements for their nourishment and growth, however, it creates a dependency that could put the farm at risk in future scenarios when this type of waste material decreases or is no longer available. Several similar projects around the world thrive on coffee waste for their success, showing us it is possible from a pragmatic point of view. Nonetheless, it is important to consider other types of waste material that could be used instead of coffee waste, adapting the farms and creating opportunities for improvement. Fungi can degrade complex carbon compounds such as plastics, oils, or gasoline. They can also degrade heavy metals, pesticides, or organic material, demonstrating that they can be the protagonist of future waste management strategies and initiatives, therefore the relevance of seeking new places for their research cultivation and expansion.

We departed our research from 3 main theories, two of them (social-ecological urbanism & biophilic design) hold a strong background in relation to the natural environment, social systems, and ecological systems. Our thesis touches upon these theories through urban symbiosis, stakeholder analyses, biophilic design, and the relevance the natural environment, directly and indirectly, has over these actors. We can affirm that our thesis is an example of these theories, although it does not completely cover all the aspects each theory has. In the case of biophilic design, we actively seek to involve and find inspiration in nature, bringing as many possible aspects into our project to be in closer connection with the natural environment and local biodiversity. On the other hand, we link our research to social-ecological urbanism theory by focusing on specific actors and the processes connected to them, seeking to improve and reinforce urban and ecosystem services.

In the spectrum of urban studies, our thesis delves into new ways of understanding urban symbiosis, where Urban Mycelium Farms function as transformative actors in the whole network of city processes. As we propose, there are many types of Urban Mycelium Farms in accordance to their location, in other words, local conditions, existing stakeholders, surrounding built environment, local biodiversity, and street network will determine the main role of the farm. Guided by the spatial conditions and design strategies we previously established, we offer a guiding path for urban planners, architects, and other professionals seeking to explore and delve into a different perspective around urban symbiosis and urban farming, particularly through mycelium.

In this thesis, mycelium is the linking concept between our research, architecture, and urbanism. Currently, mycelium has been experiencing an increase in popularity among architects due to its characteristics as a bio-based constructive material and its versatility, showing once more that as the demand for this material is increasing, mycelium farms are needed more than ever to produce them within the cities.

5.1 Conclusions & Reflections

Answer to research question & operational questions

HOW CAN MYCELIUM FARMS BE A CATALYST IN THE PROCESS OF BRIDGING THE LOCAL COMMUNITY CLOSER TO NATURE TAKING LANDALA NEIGHBOURHOOD AS A CASE STUDY IN THE CITY OF GOTHENBURG

Through urban symbiosis, connection of resource flows, and public spaces, we showcase the feasibility of creating an Urban Mycelium Farm in Landala. The parking garage and its proximity to restaurants, cafes, and public spaces made

What urban conditions are needed to identify the location of these mycelium farms in the city?

Drawing on the existing state of the art around mushroom farming, we determined 3 main aspects that help to successfully locate an urban mycelium in the city:

Urban Voids / Public Spaces

A mycelium farm is intended to «grow» in zones and spaces that are already existing in the city. If we identify spaces that have an underused dynamic, unused, or abandoned, this might be a potential spot to locate the farm.

Urban Symbiosis

The farm will be collecting waste from its surroundings to transform it into fungi-derived products. Therefore, its location has to be proximate to cafes, restaurants, and residents by walk or bicycle, this will ensure a constant circular flow of input and output resources. We suggest a radius not greater than 1km

Network Analyses

To be more connected, create a bigger impact, and transport resources efficiently, we applied concepts of Space Syntax to determine the best location for the farm. Angular Betweenness analyses showed us the streets and paths that are more prone to have a higher amount of people passing by, resulting in greater opportunities for the project to be seen, reached, and shared. Angular integration showed us the streets that are less connected to the network or intricate to reach, guiding us where not to place the farm and where it is easier to collect and distribute resources.

How can we envision these farms as systems that evolve through time bridging community, production, marketing, and consumption?

We combined elements from theory, state-of-the-art, and reference projects to answer this question.

First, theories of biophilic design guided us to create a farm concept that is tied to place-based relationships, creating connections through culture and ecology. Next, social-ecological urbanism helped us build a deeper understanding of the existing relations among stakeholders and the built environment, showing us how to improve them through design. Finally, by implementing co-produced city principles, we seek to involve society in the project. This will reshape concepts of self-governance, and participatory dynamics and acknowledge citizens' right to the city.

Studying and comparing projects with similar characteristics in different locations led us to design a farm that can work both as a production hub and a public space. Creating a farm that can change and adapt through time requires it to be closely linked to the people it benefits from and the people benefited from it, hence the relevance for it to be a space for community.

How to reach the most efficient flow of resources inputs and outputs in this new chain of mycelium production?

This question is informed by the same principles as the previous.

-Select a space that complies with the conditions of the location previously addressed

-To be in close proximity to sources of waste that can be transformed

-Identify and categorize the stakeholders involved in the flow of resources from donor to receiver

-Identify and categorize the stakeholders involved in the organization and governance of the farm

5.1 Conclusions & Reflections

Outlook & Central findings

How will these farms interact on a local scale with multiple stakeholders?

The farm will interact with residents and locals in two ways:

- 1.- Donors and receivers
- 2.- Governance involvement

The first category corresponds to all the people involved during the collection, cultivation, preparation, and delivery process. If the farm has them, it will also include research, community engagement, prototyping, and education.

The second category corresponds to all the stakeholders interacting with the farm at any level of organization and governance. This will help understand the responsibilities and necessary dynamics to make the farm feasible.

Future research

In our research, we touched upon many aspects regarding mycelium farming and social dynamics. However, we encountered fields that need further development and could not be explored in this thesis. Here we share some topics we consider relevant to think of for further research.

1.- Studying the conditions of Gothenburg regarding urban voids, showing the possibilities for these spaces to be transformed into elements of positive input to the city.

2.- Through research and adaptation of local fungi species to explore their potential and further application in production chains and waste management.

3.- Involving users in the design process. Initiate conversations, meetings, and workshops to better define the reach and turn the farms would take. Design plans where common participation and design can merge to obtain projects that serve the majority of people and their interests.

6.1 Interviews

Leonardo Rosado & Divia Jimenez Encarnacion

Interview with Leonardo Rosado



URBAN SYMBIOSIS
DONORS & RECEIVERS
MATERIAL FLOW

Biography

Leonardo has developed a groundbreaking method to account for materials in urban areas – the Urban Metabolism Analyst. The main goal is to study cities to provide valuable information to stakeholders on different levels: waste management, urban planning, industry, and households.

Relevance

This thesis addresses urban mycelium farms as a new system of urbanism functioning based on material flows.

Takeaways

Key takeaways from the discussion include the importance of urban symbiosis, which involves recognizing potential donors and receivers within a city's ecosystem. It is crucial to consider ways to disseminate knowledge effectively to small enterprises to foster sustainable development. Furthermore, logistics emerges as a central component of sustainable urban symbiosis, encompassing the sorting, adaptation, accumulation, and transportation of resources. These efforts must align closely with relevant legislation and waste regulation policies to ensure their effectiveness.

Interview with Divia Jimenez Encarnacion

Biography

Divia is a PhD student in the subject of Sharing Economy. Her research focuses on modeling consumption and sharing data at a neighborhood scale to identify pathways toward a sustainable sharing economy (Chalmers Research: Divia Jimenez Encarnacion).

Relevance

Sharing plays a significant role in the successful function of an Urban Mycelium Farm.

Takeaways

Key findings from the discussion emphasize the importance of considering various demographic factors, including gender, age, income, education levels, and household composition, when developing sustainable sharing systems. Addressing the unique challenges, needs, and motivations of end-users is crucial for fostering active participation and ensuring the success of such initiatives. Additionally, identifying consumption hotspots and targeting the most interested groups within the project are essential steps toward effectively implementing a sharing economy model.

HOTSPOTS OF CONSUMPTION
SHARING ECONOMY
IDENTIFYING NEEDS OF USERS

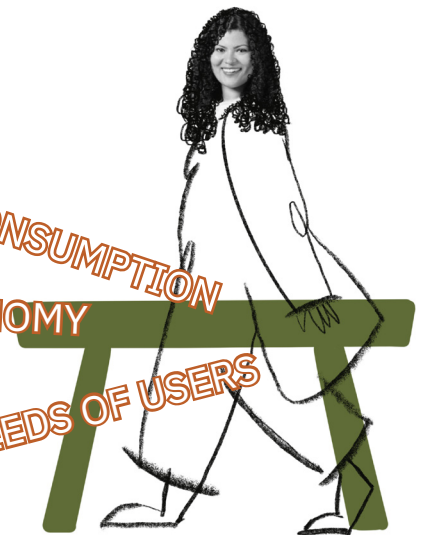

6.1 Interviews

BYGAARD

Site visit & interview at BYGAARD organic mushroom farm in Copenhagen, Denmark

Biography

«We are urban farmers, food enthusiasts and hard-working people, who believe in local and responsible food production» BYGAARD is a model of urban mushroom cultivation in the center of Copenhagen that distributes more than 6 edible species of mushroom to local restaurants and markets. They seek to keep low emissions of CO₂ transporting their products by bicycle and using organically certified waste sawdust, recycling residual products from other industries.

Relevance

BYGAARD utilizes a container cultivation system, which allows the creation of suitable and stable climates whole year round. Additionally, containers are modular and transportable, therefore making it possible to easily extend or transport the farm. On a weekly basis, they organize workshops with schools to show the process of cultivation to students. They take part in the process of production, learn about mushrooms, and develop a fonder connection with the environment through fungi.

Takeaways

The production and transportation of the fungi they cultivate are local, but they import pre-cultivated mushroom substrate from Switzerland, making only one part of the process have low CO₂ emissions. This inspired us to think of farms that could focus on the production and pre-made mushroom spawns, and other farms concentrate on producing fungi-related products.

BYGAARD is expanding the concept of local cuisine. Species of fungi that already exist in the surrounding areas of Copenhagen are being reproduced and incorporated into local gastronomy, thus creating a richer culture around food with indigenous ingredients. Because of this, fungi cultivation and mycelium production can strengthen identity values. We learned that fungi can be easily grown regardless of the size of the space. And for these spaces to work in optimal conditions, all the furniture and elements should be movable to easily clean surfaces and the space itself.





Fig 6.1 (on the left),6.2: Reusing shipping industry storage containers as cultivation rooms at BYGAARD, Copenhagen, Denmark. (Own authorship)



Fig 6.2,6.3, 6.4. Volunteer Work at BYGAARD, Copenhagen, Denmark: Unpacking and organizing mushroom substrate on shelves. (Own authorship)





Fig 6.5, 6.6, 6.7 Direct harvest of Pearl oyster mushroom (*Pleurotus ostreatus*) at BYGAARD, Copenhagen, Denmark. (Own authorship)

6.2 Mycelium Testing

With the intent to delve into the process of incubation, reproduction, and growth of mycelium and mushrooms, we collected coffee grounds from restaurants and tested different methods to cultivate Oyster mushrooms (*Pleurotus ostreatus*). The aim of these experiments is to test daily household conditions, giving us a glimpse of the level of demand mycelium/mushroom cultivation requires.

We are testing two different kinds of substrates: the first one is pure coffee grounds and the second is coffee grounds mixed with wood chips collected from the wood workshop at Chalmers.

We cultivated Oyster mushrooms so that they can be used for consumption giving an example of the process of creating food at home.



Fig. 6.8 Cultivation of mycelium at home in complete coffee ground substrate collected from restaurants. (Own authorship)

6.2 Mycelium Testing

Final Result

As products from this experiment, have a mycelium brick that can showcase the possibility of it as a building material.

The most important factor in cultivating mushrooms is making sure the sterilization process is followed accordingly.

We were able to grow mycelium, however we had many failed attempts leading to molds.

Additionally, the fresher the coffee ground is the better the results would turn out. Growing on only coffee grounds proved to give better results and fewer chances of mold than coffee grounds mixed with wood chips.



Fig.6.9 Cultivation of mycelium at home in coffee ground substrate mixed with woodchips (Own authorship)

7.1 List of Figures

Images

Gothenburg dots

<https://mrtravelersblog.blogspot.com/09/2020/top-5cities-for-visiting-in-sweden.html>

Mushroom image from cover:

<https://ommushrooms.com/pages/our-growth-process>

History Landala

Svensson, Anders. (2018, August 08). **Landala (kåkstaden)**. Göteborgs historia. Retrieved April 2024, 04 from: <https://gamlagoteborg.se/2018/08/07/landala-kakstaden/>

black and white hut

<https://www.pinterest.se/pin/508343876687362640/>

color hut

<https://www.flickr.com/photos/33772732@N3375601660/05/>

Mycelium

Fungi anatomy

Ward, S. (2016). Fungi. SlidePlayer. <https://slideplayer.com/slide/9361210/>

Plant and mycorrhiza

Karas, Sheryl. (n.d.). How the Fungi Might Save Us. California State University Chico. <https://www.csuchico.edu/regenerativeagriculture/blog/how-fungus-might-save-us.shtml>

Mycorrhiza

Cobb, Adam. (2020). Mycorrhizal Fungi - Our Tiny Underground Allies. ECHO Asia Note Articles. 43. <https://www.echocommunity.org/resources/2494c-4773-7310-049ad-49fe2699331125>

Mycorrhizal network

Beiler, K.J., Durall, D.M., Simard, S.W., Maxwell, S.A. and Kretzer, A.M. (2010), Architecture of the wood-wide web: *Rhizopogon* spp. genets link multiple Douglas-fir cohorts. *New Phytologist*, 553-543 :185. <https://doi.org/10.1111/j.8137.2009.03069-1469.x>

Farming Japan

Sugimoto, Kazuhide. (2020). Sugimoto. Retrieved April 23, 2024, from: <https://sugimoto.co/en/about-us/factory/>

industrial farm

Farmer. (2021, June 25). **Mushroom Farming Cost And Profit**. Farm House. <https://farmhose.blogspot.com/2021/04/mushroom-farming-cost-and-profit.html>

8.1 Bibliography

- 1 Nguyen, M. (2021, September 02). Is mushroom architecture the next thing? Archi Hacks. Retrieved September 2023 ,15, from <https://archihacks.com/is-mushroom-architecture-the-next-thing/>
- 2 Frearson, A. (2017, September 04). Tree-shaped structures show how mushroom roots could be used to create buildings. Dezeen. Retrieved September 2023 ,15, from <https://www.dezeen.com/04/09/2017/mycotree-dirk-hebel-philippe-block-mushroom-mycelium-building-structure-seoul-biennale/>
- 3 Souza, E. (2020, October 12). Mushroom buildings? The possibilities of Using Mycelium in Architecture. Dezeen. Retrieved September 2023 ,15, from <https://www.archdaily.com/949007/mushroom-buildings-the-possibilities-of-using-mycelium-in-architecture>
- 4 Verge Science. (2021, February 02). This mushroom brick could replace concrete. [Video]. Retrieved September 2023 ,15, from <https://www.youtube.com/watch?v=Pp7pSlwILLA>
- 5 Mena, V. & Putzolu, L. (2015). Biodiver-city: Spreading and sharing space in a city context. [Master's thesis, Chalmers University of Technology]. Chalmers School of Architecture. <https://odr.chalmers.se/items/063056de4-e99-4503-04a-0f15b8cb45249>
- 6 Ollar, A. & Horn-Jademarm S. (2015). Myco: an investigation into growing building materials. [Master's thesis, Chalmers University of Technology]. Chalmers School of Architecture. <https://odr.chalmers.se/items/5f64ba-48ee4-56f0e-b0-355ed909161aa8>
- 7 Naraine, J. (2022). Carbon Positive Food Regions. Design and planning strategies to co-create regenerative food systems. [Master's thesis, Chalmers University of Technology]. Chalmers School of Architecture. <https://odr.chalmers.se/items/b00b585b4-e4-94f8b-a-35901b6d238b3c2>
- 8 Chen, J. (2021). Urban (Circular) Food System. Facilitating circular food production model in Gothenburg. [Master's thesis, Chalmers University of Technology]. Chalmers School of Architecture. <https://projects.arch.chalmers.se/juntian-chen/>
- 9 Damsten, P & Rama, K. (2018). Urban Agriculture for a Sustainable Future. Co-creating Strategies for Scaling up Urban Agriculture in the City of Gothenburg. [Master's thesis, Chalmers University of Technology]. Department of Earth and Space Sciences. <https://projects.arch.chalmers.se/juntian-chen/>
- 10 Lemaitre, E. (2022). Life Cycle Assessment of Urban Underground Oyster Mushrooms Farming. [Degree Project, KTH Royal Institute of Technology]. Department of Sustainable Development, Environmental Science and Engineering. <https://www.diva-portal.org/smash/record.jsf?pid=diva3%2A1720519&dswid=9381->
- 11 Hernández, R. (2021). Matrum: A space for learning, experimenting & sharing food around. [Master's thesis, Chalmers University of Technology]. Chalmers School of Architecture. <https://projects.arch.chalmers.se/raquel-hernandez-pacheco/>
- 12 Spoon, S. (2023). Public spaces through urban farming. [Master's thesis, Delft University of Technology]. TU Delft Architecture and the Built Environment, TU Delft Architectural Engineering. <http://resolver.tudelft.nl/uuid:f9069d7b4-a8b85-4881-f-5468f9a9154f4>
- 13 TED. (2008, March). 6 ways mushrooms can save the world | Paul Stamets. [Video]. Retrieved September 2023 ,15, from https://www.ted.com/talks/paul_stamets_6_ways_mushrooms_can_save_the_world
- 14 Insider Español. (2023, April 18). Empresas emergentes usan hongos para luchar contra residuos | Basura del mundo. [Video]. Retrieved September 2023 ,15, from <https://www.youtube.com/watch?v=nmBPYN-nwpI>
- 15 Bayer, E & McIntyre, G. (2007). Ecovative Mycelium Technology. Retrieved September 2023 ,15, from <https://www.ecovative.com>
- 16 Bayer, E & McIntyre, G. (2020). MyForestFoods. Retrieved September 15, 2023, from <https://myforestfoods.com>
- 17 Nair, R. (2018). Mycorena. Retrieved September 2023 ,15, from <https://.com>

8.1 Bibliography

- 18 Ollar, A. & Horn-Jademark S. (2015). Myco: an investigation into growing building materials. [Master's thesis, Chalmers University of Technology]. Chalmers School of Architecture. <https://odr.chalmers.se/items/5f64ba-48ee4-56f0e-b0-355ed909161aa8>
- 19 TED. (2022, April). The future of fashion -- made from mushrooms | Dan Widmaier. [Video]. Retrieved September 2023 ,15, from https://www.ted.com/talks/dan_widmaier_the_future_of_fashion_made_from_mushrooms
- 20 Widmaier, D. (2009). Mylo. Retrieved September 2023 ,15, from <https://mylo-unleather.com/boltthreads.com>
- 21 Damsten, P & Rama, K. (2018). Urban Agriculture for a Sustainable Future. Co-creating Strategies for Scaling up Urban Agriculture in the City of Gothenburg. [Master's thesis, Chalmers University of Technology]. Department of Earth and Space Sciences. <https://projects.arch.chalmers.se/juntian-chen/>
- 22 Westhoff, L & Hendriks, B. (2020). Loop Biotech. Retrieved September 2023 ,15, from <https://loop-biotech.com/>
- 23 ARTE.tv Documentales. (2022, November 19). Hongos y sostenibilidad. [Video]. Retrieved September 2023 ,15, from <https://www.youtube.com/watch?v=KzyO3p3qTpY>
- 24 Jaquet, J. (2014). Permafungi. Retrieved September 2023 ,15, from <https://www.permafungi.be/en/>
- 25 Péchard, Cédric. (2009). La boîte a champignons. Retrieved September 2023 ,15, from <https://laboiteachampignons.com>
- 26 Kellert, S. R., & Heerwagen, J. H. (2008, p.-292-293). Biophilic Design: the theory, science, and practice of bringing buildings to life. John Wiley & Sons.
- 27 Beatley, T. (2000). Green Urbanism: Learning from European Cities. Island Press.
- 28 Dickey, M. (2017). Urban rage; the revolt of the excluded. Yale University Press New Haven and London.
- 29 Grahn, P. (1994). Green structures - The importance for Health of nature areas and parks (Vol. 56). European Regional Planning.
- 30 Harvey, D. (2015). Seventeen contradictions and the end of capitalism. Profile Books LTD.
- 31 Hillier, B. (1996). The Space is the Machine: A Configurational Theory of Architecture. Cambridge University Press, Cambridge.
- 32 Low, N., & Gleesow, B. (1998). Justice, Society, and Nature an exploration of political ecology. Routledge.
- 33 Martin, L. (1972). The Grid as Generator. Cambridge University Press, Cambridge.
- 34 Norberg-Hodge, H. (1991). Ancient Futures: Learning from Ladakh. Oxford University Press.
- 35 Panizzut, N. (2021). Cleaner Engineering and Technology. In Exploring the relationship between environmentalism and consumerism in a market economy society: A structured systematic literature review, 2. <https://doi.org/10.1016/j.clet.2021.100047>
- 36 TED. (2022, October 14). How to Revitalize a Neighborhood -- Without Gentrification | Bree Jones. [Video]. Retrieved May 2023 ,14, from: https://www.youtube.com/watch?v=cNyH_RBpt7s&list=PLy4QiL3Y5p8fK_Vb8eHEtooKz_Fh2mJLB2&index=2&ab_channel=TED
- 37 Thörn, C., & Holgersson, H. (2016). Revisiting the urban frontier through the case of New Kvillebäcken, Gothenburg, City. 684-663 ,(20)5. DOI: 13604813.2016.1224479/10.1080, S. R., & Heerwagen, J. H. (2008, p.293-292). Biophilic Design: the theory, science, and practice of bringing buildings to life. John Wiley & Sons.
- Circular Economy
- 38 Grimm, D., Kuenz, A. & Rahmann, G. Integration of mushroom production into circular food chains. Org. Agr. 2021) 317–309 ,(11). <https://doi.org/10.1007/s-00318-020-13165y>
- 39 Grimm, D., Wösten, H.A.B. Mushroom cultivation in the circular economy. Appl Microbiol Biotechnol 2018) 7803–7795 ,(102). <https://doi.org/10.1007/s8-9226-018-00253>

8.1 Bibliography

Subject & problem description, conflict

40 United Nations, Department of Economic and Social Affairs, Population Division (2018). *The World's Cities in 2018—Data Booklet (ST/ESA/SER.A/417)*

41 WWF. 2018. **Living planet report 2018 - Building a nature positive society** [Online]. Retrieved on Mar 20, 2024. Available at: <https://www.wwf.org.uk/our-reports/living-planet-report-2022>

42 Grahn, Patrick. (2023). **The importance of nature for human health and well-being**. Department of People and Society, Swedish University of Agricultural Sciences (SLU).

43 Nilsson, Kjell & Grahn, Patrick. (2024) **The scientific evidence for nature's positive influence on human health and well-being. Green and healthy nordic cities how to plan, design, and manage health-promoting urban green space**. NORDGREEN.
<http://doi.org/10.6027/R2503-2024:11403>

Sustainability relevance

44 Jaquet, J. (2014). Permafungi. Retrieved September 2023 ,15, from <https://www.permafungi.be/en/>

45 Péchard, Cédric. (2009). *La boîte a champignons*. Retrieved September 15, 2023. Available at: <https://laboiteachampignons.com>

46 Cornell College of Agriculture and Life Sciences - Cornell Small Farms Program. (2021) **Community Mushroom Educator Network**. Retrieved February 10, 2024. Available at: <https://smallfarms.cornell.edu/projects/mushrooms/cme/>

47 Gertz, Jean-Noël.(2017). *La Caverne*. Retrieved January 2024, 26. Available at: <https://lacaverne.co/>

48 UN General Assembly, **Transforming our world: the 2030 Agenda for Sustainable Development**, A/RES/70/1, 21 October 2015. Retrieved March 10, 2024. Available at: <https://www.refworld.org/legal/resolution/unga/2015/en/111816>.

49 Sofie Rosengren, Lisa. (2012). **Community Gardens in Gothenburg: Local Counter-actions in the Age of Globalization? A Qualitative Study on Motives behind Urban Agriculture in Gothenburg**. [Masters Thesis, Gothenburg University]. Gothenburg University Library. Available at: <https://gupea.ub.gu.se/handle/29590/2077>

50 Castle Forest Colony / Slottskogskolonien (1916). Retrieved February 2024 ,10. Available at: <https://www.slottskogskolonien.se/>

Methodology

51 Huang, Lun & Xie, Yibo & Chen, Xiaolin. (2021). **A Review of Functions of Speculative Thinking**. *Frontiers in Psychology*. 10.3389 .728946 .12/fpsyg.2021.728946.

Social-ecological urbanism

52 Raufflet, Emmanuel. (2000). Berkes, F., and C. Folke, editors. 1998. *Linking Social and Ecological Systems: Management Practices and Social Mechanisms for Building Resilience*. Cambridge University Press, New York. *Ecology and Society*. 4. XIX-XX. 10.5751/ES-00202-040205.

53 Barthel, S., Colding, J., Ernstson, H., Erixon, H., Grahn, S., Kärsten, C., Marcus, L., Torsvall, J. (2013). **Principles of Social-Ecological Urbanism - Case Study: Albano Campus, Stockholm**. Stockholm, Sweden: Stockholm Resilience Centre

54 Tiderman Häll, Amanda. (2023). **Planning for Pollination - creating cohabitation through social-ecological urbanism**. [Masters Thesis, Chalmers University of Technology]. Chalmers Open Digital Repository. <https://odr.chalmers.se/items/04dbaad8-a480-4202-9df9-c6212504ac9b>

55 Lindroth, Maja & Svensson, Matilda. (2023). **After dark - Social-ecological public space from a darkness perspective**. [Master Thesis, Chalmers University of Technology]. Chalmers Open Digital Repository. <https://odr.chalmers.se/items/be56d933-d2ce-4a7e-a50f-200f0425179e>

8.1 Bibliography

Co-produced City

56 Petcou, C., & Petrescu, D. (2015). R-URBAN or how to co-produce a resilient city. *Ephemera*. <https://eprints.whiterose.ac.uk/98764/>

57 Petrescu, D., Petcou, C., & Baibarac, C. (2016). Co-producing commons-based resilience: lessons from R-Urban. *Building Research and Information/Building Research & Information*, 44(7), 717–736. <https://doi.org/10.1080/09613218.2016.1214891>

58 Petrescu, D., Petcou, C., Safri, M., & Gibson, K. (2020). Calculating the value of the commons: Generating resilient urban futures. *Environmental Policy and Governance*, 31(3), 159–174. <https://doi.org/10.1002/eet.1890>

Mycelium

59 Stamets, Paul. (2005). **Mycelium running: How mushrooms can help save the world**. Berkeley, Calif: Ten Speed Press.

60 Popkin, Gabriel. (May 15, 2019). **Wood Wide Web- the underground network of microbes that connect trees- mapped for the first time**. *Science*. <https://www.science.org/content/article/wood-wide-web-underground-network-microbes-connects-trees-mapped-first-time>

61 Fricker, Mark & Heaton, Luke & Jones, Nick & Boddy, Lynne. (2017). The Mycelium as a Network. *Microbiology Spectrum*. 5. 10.1128/microbiolspec.FUNK-0033-2017.

62 Ciencia Contada al Español. SINC. (2015). **Un yacimiento cántabro alberga la primera evidencia del consumo humano de setas**. Universidad de Valencia. <https://www.agenciasinc.es/Noticias/Un-yacimiento-to-cantabro-alberga-la-primer-evidencia-del-consumo-humano-de-setas>

63 GroCycle. (October 4, 2015). **The History of Mushroom Cultivation**. [Video]. Retrieved April 14, 2024, from: https://www.youtube.com/watch?v=gt-_Mmd-KAVA&ab_channel=GroCycle

64 Bayer, Eben. (July 1, 2019). **The Mycelium Revolution Is upon Us**. *The Scientific American*. <https://www.scientificamerican.com/blog/observations/the-mycelium-revolution-is-upon-us/>

65 Horlick, C. (July 5, 2023). **Fungi: the hidden heroes of ecosystems**. *Earth.Org*. <https://earth.org/fungi-the-hidden-heroes-of-ecosystems/>

66 Antinori, M.E., Contardi, M., Suarato, G. et al. (2021). **Advanced mycelium materials as potential self-growing biomedical scaffolds**. *Sci Rep* 11, 12630. <https://doi.org/10.1038/s41598-021-91572-x>

67 Gabriel, S. (2024, January 16). **Community Mushroom Educator Program - Cornell Small Farms**. Cornell Small Farms. <https://smallfarms.cornell.edu/projects/mushrooms/cme/>

68 Surtees, J. (2023, January 16). **How mushrooms could mean economic independence for Benin's women**. *The Guardian*. <https://www.theguardian.com/global-development/2023/jan/03/mushrooms-could-mean-economic-independence-for-benin-women>

69 Darwish, L. (2020, February 22). **Women in bioremediation**. *Earth Repair*. <https://earthrepair.ca/women-in-bioremediation/>

70 Crew, B. (2016, March 2). **This device turns plastic waste into safe, edible mushrooms**. *ScienceAlert*. <https://www.sciencealert.com/this-device-turns-plastic-waste-into-safe-edible-mushrooms>

71 Daniel. (2023, September 7). **Slottsskogskolonien**. *Slottsskogskolonien*. <https://www.slottsskogskolonien.se/>

72 Kernser Edelpilze GmbH - Schweizer BIO-Pilze. (1995). Retrieved from: <https://www.kernser-edelpilze.ch/>

Collage Reference

73 Behance. (n.d.-b). <https://www.behance.net/gallery/105848991/Meal-Distribution-Center>

74 Idea 2156262: Practicing by ArchStudio in Beijing, China. (n.d.). *Architizer*. <https://architizer.com/idea/2156262/>

75 Taylor-Foster, J. (2017, September 14). **Kickstarter campaign to activate vacant storefronts in New York City**. *ArchDaily*. <https://www.archdaily.com/430477/kickstarter-campaign-to-activate-vacant-storefronts-in-new-york-city>

76 Silhouette drawings. (n.d.). *Pinimg*. <https://i.pinimg.com/originals/6c/fc/a0/6cfca0582347f2e462ffbb5d053895ed.jpg>

8.1 Bibliography

mycelium and architecture

77 McGaw, J., Andrianopoulos, A., Liuti, A. (May 27, 2022). **Tangled Tales of Mycelium and Architecture: Learnings From Failure**. *Frontiers in built environment*. Volume 8. DOI: 10.3389/fbuil.2022.805292

78 Sayner, Adam & Jong Eric. (2009). GroCycle. Retrieved March 2023, 14, from: <https://grocycle.com/>

79 GroCycle. (April 6, 2020). **Designing a Mushroom Farm**. [Video]. Retrieved April 18, 2024, from: https://www.youtube.com/watch?v=6O11oKWAwFI&ab_channel=GroCycle

State of the art

80 Global mushroom market to grow at a CAGR of 8% in the forecast period, aided by the growing health consciousness among consumers. (2023). Expert Market Research. <https://www.expertmarketresearch.com/pressrelease/global-mushroom-market>

81 Ostendorf-Rodríguez, Y. (2023). **Let's Become Fungal!: Mycelium Teachings and the Arts: based on conversations with Indigenous wisdom keepers, artists, curators, feminists and mycologists**. Valiz, Amsterdam.

82 GroCycle. (2024, March 5). **The Mushroom Market is Booming! | GroCycle #shorts** [Video]. YouTube. <https://www.youtube.com/watch?v=d6cJUJgfjIw>

Master Thesis References

83 Harmuth, H. (2023). **Place through encounter - an exploration of a Third Place in the urban context of Partille**. (Master's thesis, Chalmers University of Technology, Gothenburg, Sweden).

84 Shiru, L. (2023). **Towards a Sustainable and Liveable Desakota: Designing for sustainable industry transition in the peri-urban territory of the Greater Bay Area**. (Master's thesis, Delft University of Technology, Delft, Netherlands).

Reference Projects

85 PermaFungi | **Changer le monde grâce au champignon**. (n.d.). <https://www.permafungi.be/>

86 **La Boîte à Champignons culture des pleurotes sur marc de café**. (n.d.). Kropstek. <https://www.laboitea-champignons.com/>

87 **La Caverne, mushroom houses in the parking lots**. (n.d.). <https://www.energy-observer.media/en/solutions/videos/la-caverne-mushroom-houses-parking-lots>

88 BYGAARD. (n.d.). Bygaard. <https://www.bygaard.dk/>

89 Amisacho – **Cultivo de Hongos Comestibles**. (n.d.). <https://amisacho.com/>

90 rotterzwam. (n.d.). koffiedik ophalen & duurzame webshop. Rotterzwam. <https://www.rotterzwam.nl/>

91 Hut und Stiel. (n.d.). Hut & Stiel GmbH. <https://www.hutundstiel.at/>

92 Rise, T. W. (2021, March 29). **Africa Development Promise - Together Women Rise**. Together Women Rise -. <https://togetherwomenrise.org/programfactsheets/africa-development-promise/>

