

The Complexity and Contradiction in Space

Pengyu Chen

Chalmers School of Architecture
Department of Architecture and Civil engineering
Examiner: Morten Lund
Supervisor: Peter Christensson



CHALMERS
UNIVERSITY OF TECHNOLOGY

Pengyu Chen

The Complexity and Contradiction in Space
Chalmers School of Architecture
Department of Architecture and Civil engineering
Master program of Architecture and Urban Design
Master Thesis Spring 2020
Matter, Space, Structure
Examiner: Morten Lund
Supervisor: Peter Christensson

Student background

Bachelor of Architecture

China University of Mining and Technology

Master's Program

Architecture and Urban Planning
Chalmers University of Technology

Oslo School of Architecture and Design(Erasmus Exchange Program)
Guest Studio(Valerio Olgiati)

Work Experience

Internship at UNStudio,Amsterdam,Netherlands

CONTENT

<i>Abstract</i>	4
<i>Introduction</i>	
Background	5
Method	6
Aim&Question	7
Theory	8
Delimitation	9
Reading instruction	10
<i>Chapter 1.Contradition</i>	11
Symmetry	12
Alienation	13
Sequence	14
Intellectual perception	15
Intervention	16
Abstractness	17
<i>Iterations</i>	18
A space with two staircases	19
A space with a hidden basement	23
A space with two cross over-lapping beams	27
<i>Chapter 2.Complexity</i>	32
Skeleton	33
Iteration_A space defined by skeleton	36
Dimension	39
Iteration_A space defined by skeleton	41
Division	45
Iteration_A space defined by skeleton	52
<i>Chapter 3.Design</i>	58
Life and Death	59
Intention	60
Context	61
Analysis	62
Contradiction&Complexity in design project	66
Drawings	71
Renderings	76
<i>Discussion</i>	79
<i>Reference</i>	80

Abstract

The idea of the Master thesis is to conclude a methodology that defines the contradiction and complexity in an architectonic space as well as prototypes (spatial prototype) that are potentially infinite, an endless sequence of reiterations, combinations through a series of abstract and clear rules, and theoretically understands and thinks about the essence of space.

The method of the thesis would be focusing on the research regarding the definition of contradiction and complexity in space through case study and references, acquiring the concluded spatial prototypes of iterations. This thesis project is primarily driven by research through iterations of contradiction and complexity in space, working artistically and exploratorily. The design research is divided into two chapters, one in which I develop a methodology to materialize the contradiction and complexity, one in which previous research, as well as interactions, will be integrated in an architectural design project within the urban context.

Overall, one aim of this master thesis is to understand the essence of space through contradiction and complexity and eventually conclude a methodology as a design language that uses the complexity to explain the contradiction in space. And the other one is an awareness of architectural autonomy, which influences how we perceive, evaluate, and interact with contradiction and complexity in space.

Keywords:

Contradiction, Complexity, Architectonic, spatial sequence, spatial experience, prototype

Background



A table with a column

A corner of the table was cut off by the positioning of the column in order to fit in and align to the row of tables in front, thus restricting how users organize their desktop and creating a unique table in this contradicted context at the office.

Gestalt Psychology's research believes that people's perception of simple things is relatively easy, and it is easy to obtain a relaxed and comfortable feeling, which, however, is relatively light. While, It 's more difficult to perceive the complexity and contradiction, which might evoke a sense of tension, and it is necessary to carry out positive consciousness. But once completed and the tension is gone, people will get more aesthetic satisfaction. Overall, complex and contradictory stimulation often leaves a deep impression on people.

The thesis aims to investigate the contradiction and complexity in space through spatial experience formed by purely architectural elements.

WORKING METHOD

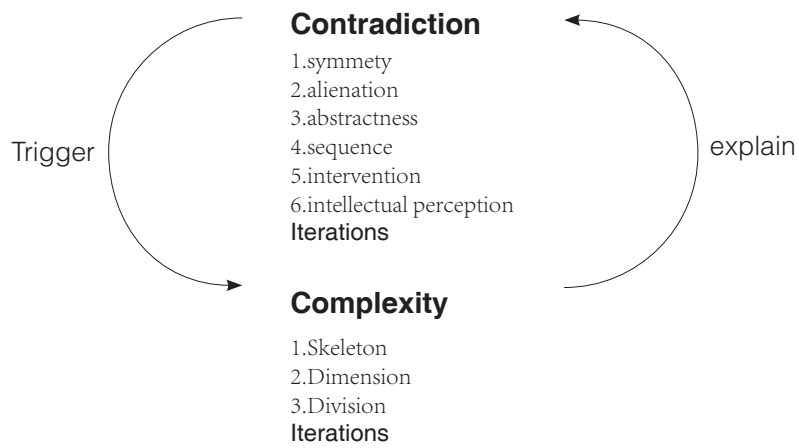

Design project:Experiment

House for a priest with a hidden graveyard

THESIS QUESTION

- What is the definition of contradiction and complexity ?
- How can users have holistic approach and understanding of space through contradiction and complexity?
- How to use contradiction and complexity as a method force to design a project in a certain context?

AIM

- Investigate the factors in contradiction and complexity in space and logic and reason behind.
- Design a project that contains the contradiction and complexity in space, through which users can have different perspectives of architecture embedded in spatial experience and sequence.

THEORY

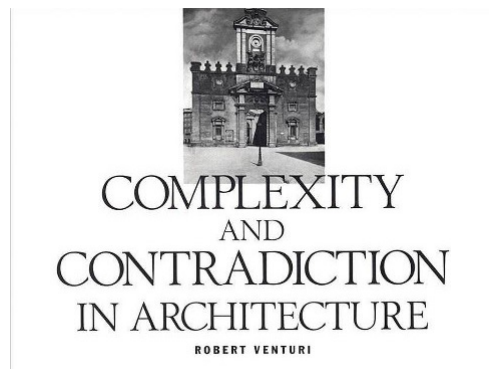

The book of Robert Venturi is the fundamental reference and theory for the Master thesis that explain the complexity and contradiction of architecture, while I try to narrow it down within the discourse of architectonic spaces, illustrating both topics through the case study and references, concluding my own space study library that can be experimented by practice not just for Master thesis but also further professional practice.

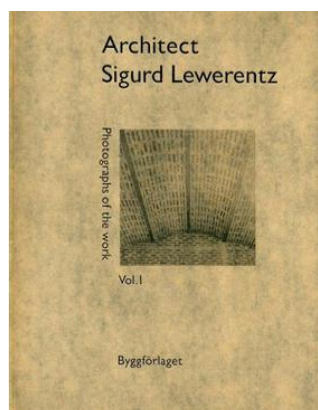
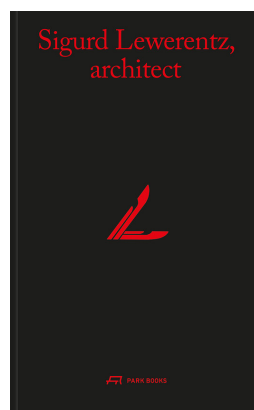

When it comes to the design project integrated with complexity and contradiction in space, I choose the Malmo eastern cemetery designed by Sigurd Lewerentz as my site, so his idea "Landscape as a monument" behind the winning proposal for that trigger me to look into the existing contradiction and complexity in the landscape, and try to reflect and respond to that within the intervention of architectural spaces created.

DELIMITATIONS

Fundamental Theory

The complexity and contradiction of Architecture is the fundamental theory of the Master thesis, I try to narrow down the discourse of architecture in theory into spaces only, elaborating how can users perceive the contradiction and complexity through spatial experience and sequences.



Discourse

6 Characters of contradiction in space
3 Definitions of complexity in space
Design project as an experiment integrated with contradiction and complexity in a specific context

TARGET

Architectonic space = Spatial sequence + experience

READING INSTRUCTION

The readers shall follow the order of the booklet to understand the definition of contradiction and complexity respectively through case study and iterations of those two topics in space, then the final design project would be the testbed for the practicability of the discourse of contradiction and complexity in space as Master thesis.

01

Contradiction

Contradiction adapted is tolerant and pliable. It admits improvisation. It involves the disintegration of a prototype—and it ends in approximation and qualification. On the other hand, contradiction juxtaposed is unbending. It contains violent contrasts and uncompromising oppositions. Contradiction adapted ends in a whole which is perhaps impure. Contradiction juxtaposed ends in a whole which is perhaps unresolved.

-Robert Venturi's

Contradiction in Space

Symmetry

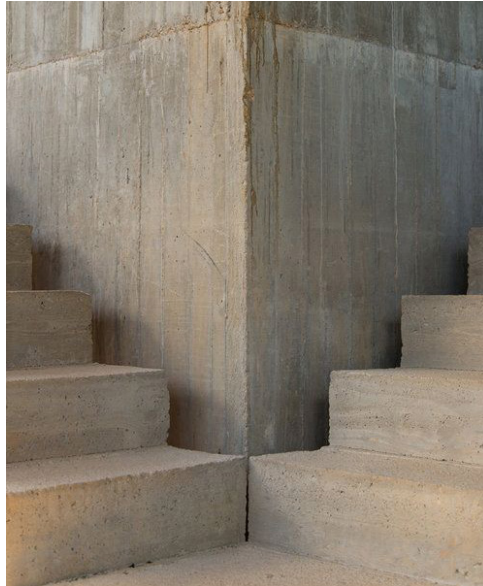

Pezo von Ellrichshausen Solo House

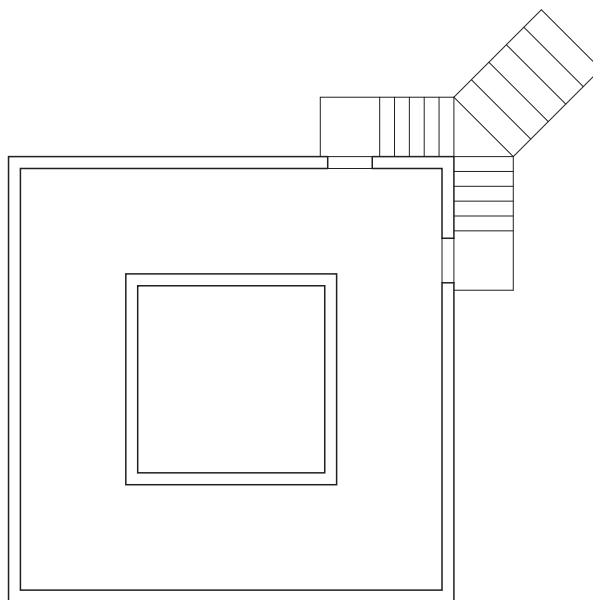

Before entering the indoor space of the solo house, a contradiction is raised regarding the existence of a bifurcated and symmetrical staircase leading to two doors at the entrance, the mystery is revealed the moment when people enter the space with a symmetrical geometry.

Contradiction in Space

Alienation



Fatehpur Sikri, India

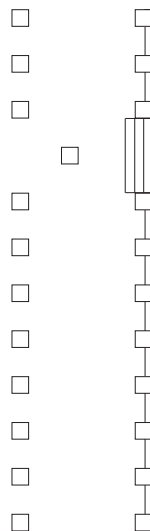

The corridor in Fatehpur Sikri is defined by two rows of columns aligned towards the landscape and on the wall, while one column standing out among the rows creates a dynamic and contradictory scenario in contrast with the aligned columns, an indication of the entrance becomes more clear as you walk towards it.

Contradiction in Space

Sequence



National Park Centre ,Zernez, Switzerland,Valerio Olgiati,2008

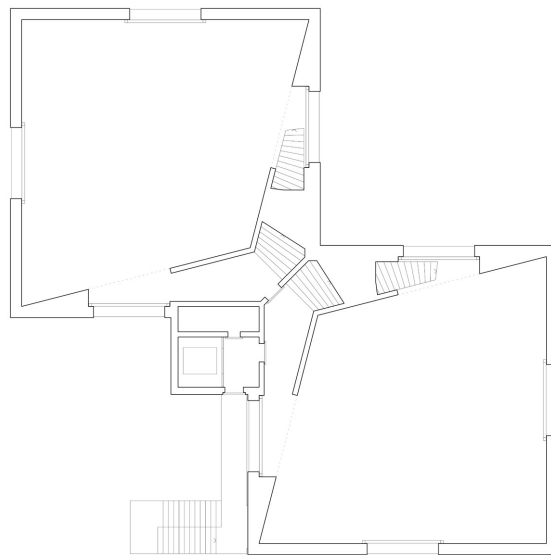

A wide staircase is suddenly separated after several steps from the ground floor, and the tourists suddenly have no clue where to go as the separated stairs were the same size and the same. However, the confusion from the contradiction is simply eliminated as the tourists can have a holistic understanding of the space through the spatial experience of the flow, no matter which staircase they decide.

Contradiction in Space

Intellectual perception



Itabu toilet, Ichihara, Japan, Sou Fujimoto

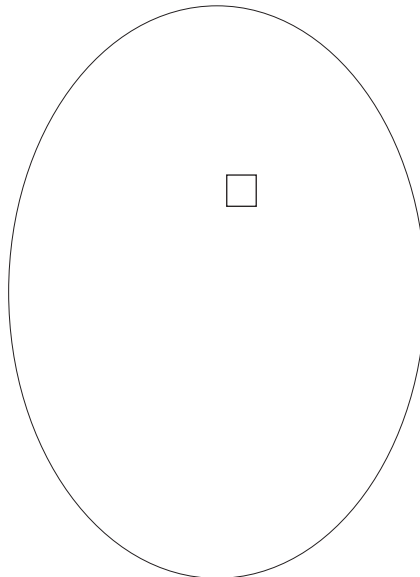

A glass box lavatory that has been placed in the middle of a 200 square meters garden that is planted with trees and flowers, providing occupants a serene view while using the facilities, creating a strong contradiction between privacy and publicity, and challenging the original intellectual perception of a bathroom and user experience while.

Contradiction in Space

Intervention



Plantahof Auditorium ,Valerio Olgiati,2010

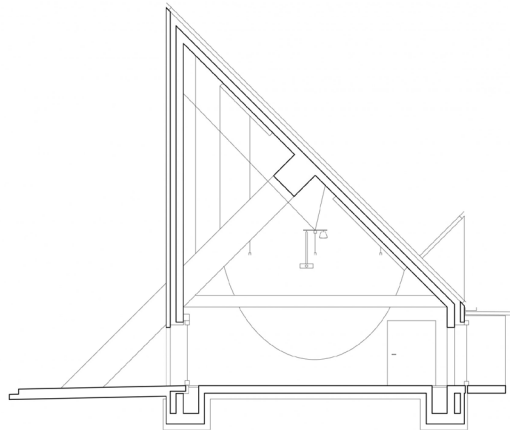

The architect systematically presents the process of how "contradictions" trigger thought. The 12-meter high wall on the front of the lecture hall is the most obvious feature of this building, which enhances the sense of enclosure in the auditorium, while a diagonally supported short column. People cannot fully understand the way the building is established from the outside without the holistic spatial experience of the skeleton. The contradiction between structure and maintenance form a mystery, which attracts people to participate in and interact with it to understand the puzzle.

Contradiction in Space

Abstractness



House in white, Japan ,Kazuo Shinohara,1966

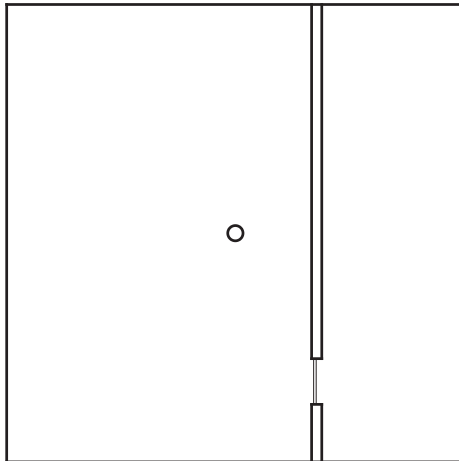

The monumentality of the column in the center is decreased by the partition wall with a ratio of 2:1 in the space, blurring the depth between the column and the wall by the position of the visual perspective.

Iterations of Contradiction in Space

1

A space with two stairs



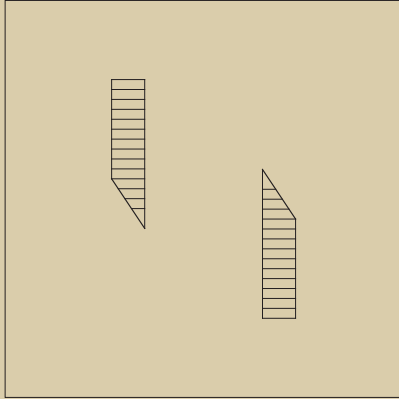

Existence of two staircases
in one space

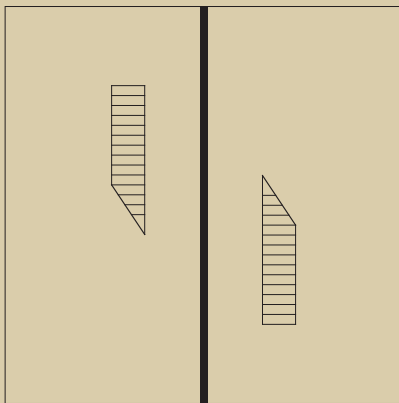

Existence of two staircases in
a separated space

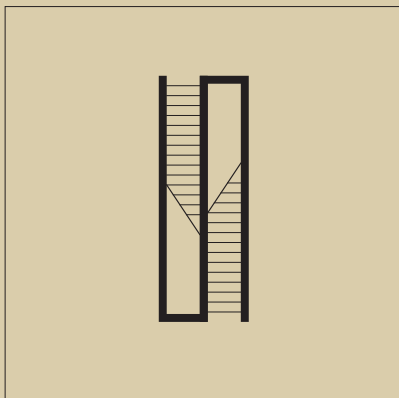

Existence of two staircases
in one space, perceived by
the holistic approach

A space with two stairs

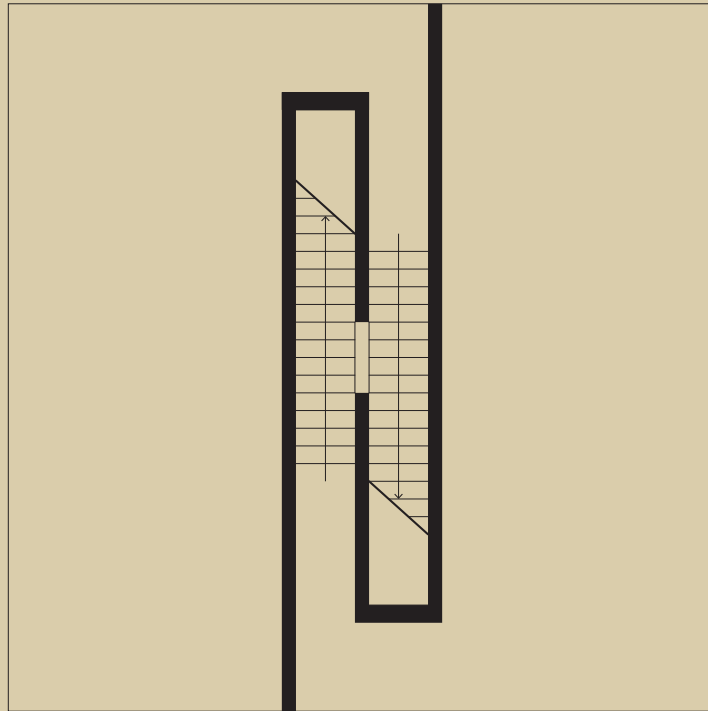

Ground floor

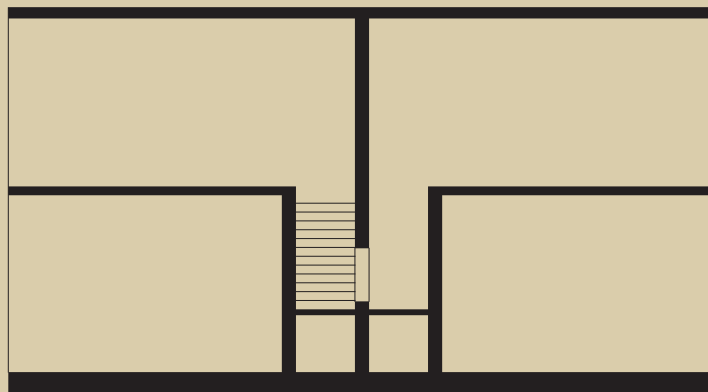

Section

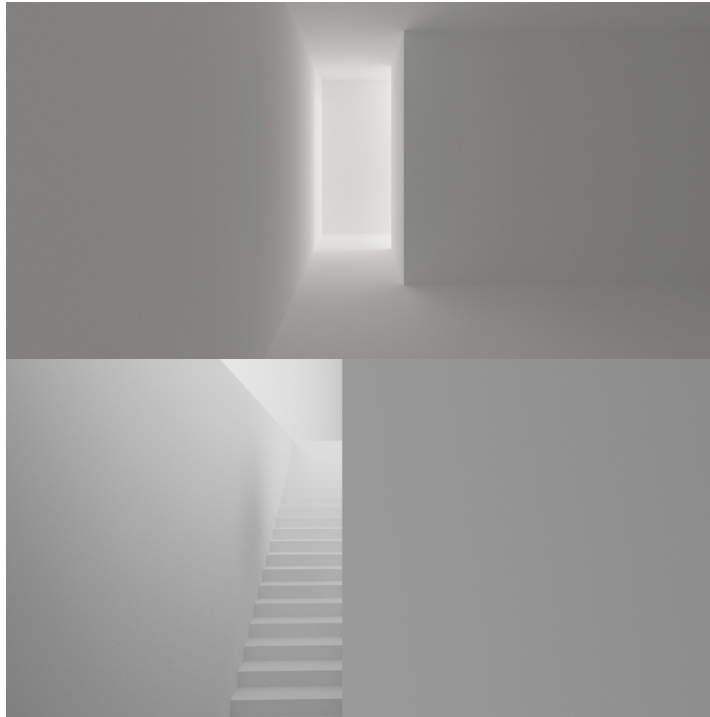

Light comes in and gives an indication of the space behind in the darkness.
A hidden stair shows up and leads to the upper floor, starting to be away from the darkness.

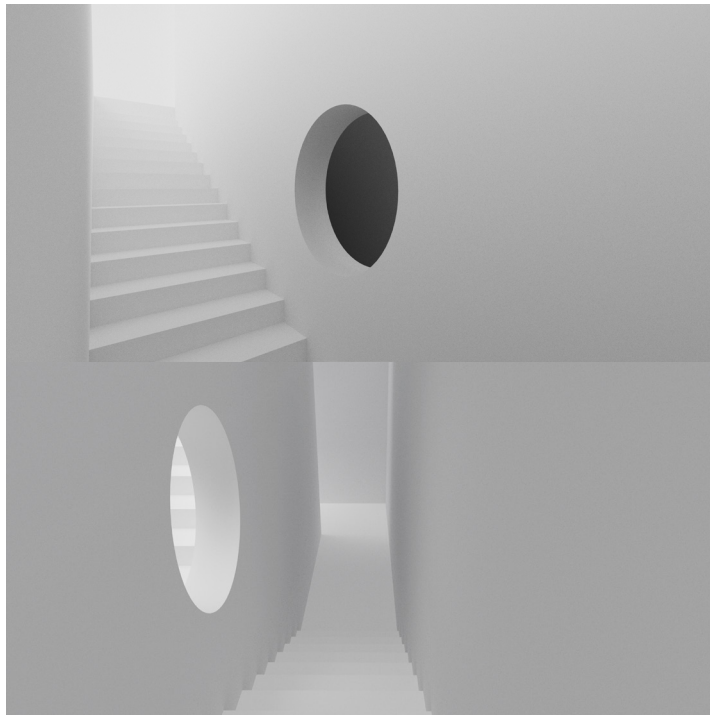

Through the spatial sequence of the upper floor, an overall understanding of contradiction is acquired and puzzle becomes clear now, turning staircases into objects in dark space, deep and mysterious.

The contradiction is embedded in the requirement of architectural components.

2

A space with a hidden basement

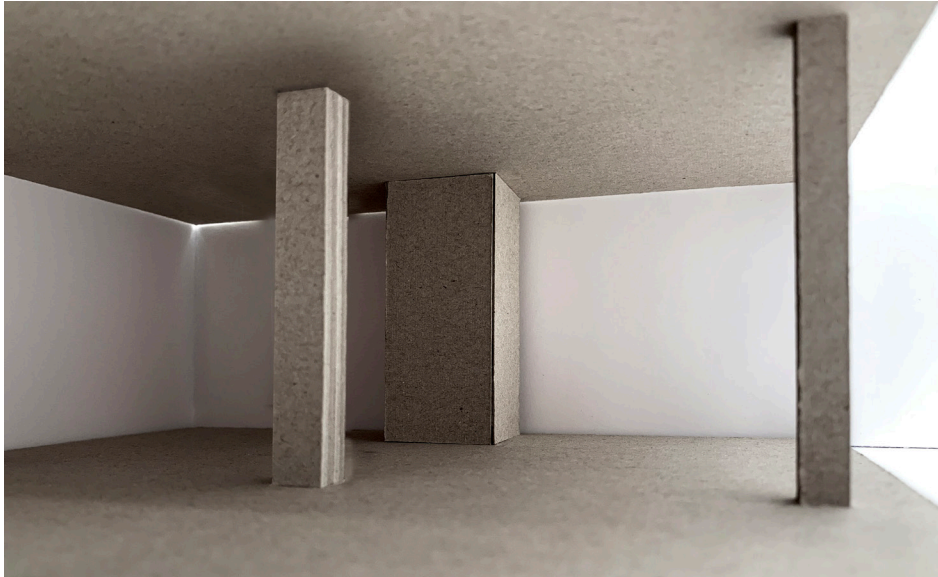

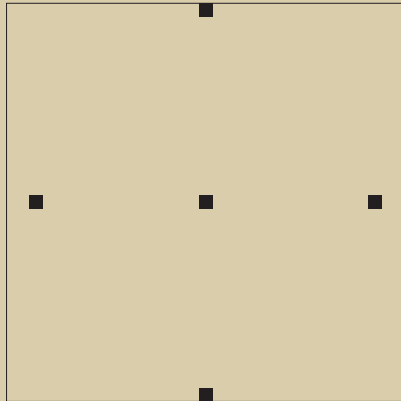

Five columns with same dimension positioned in one space

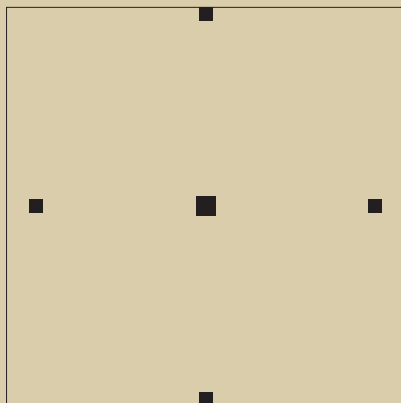

Five columns with one in the center larger than the others

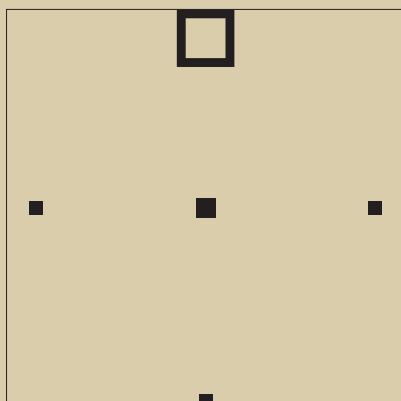

Five columns with one on one edge larger than the others, placed as a core in the space

Prototype

A space with hidden basement

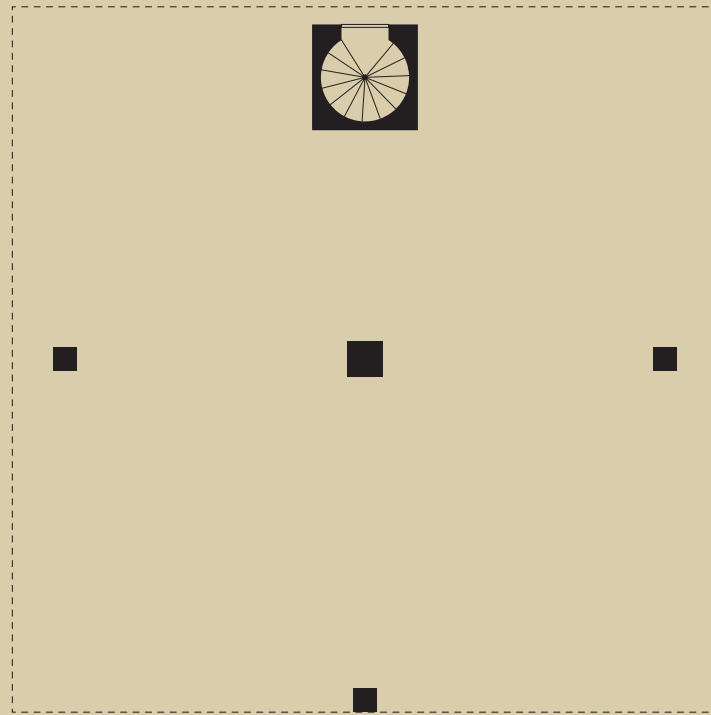

Ground floor

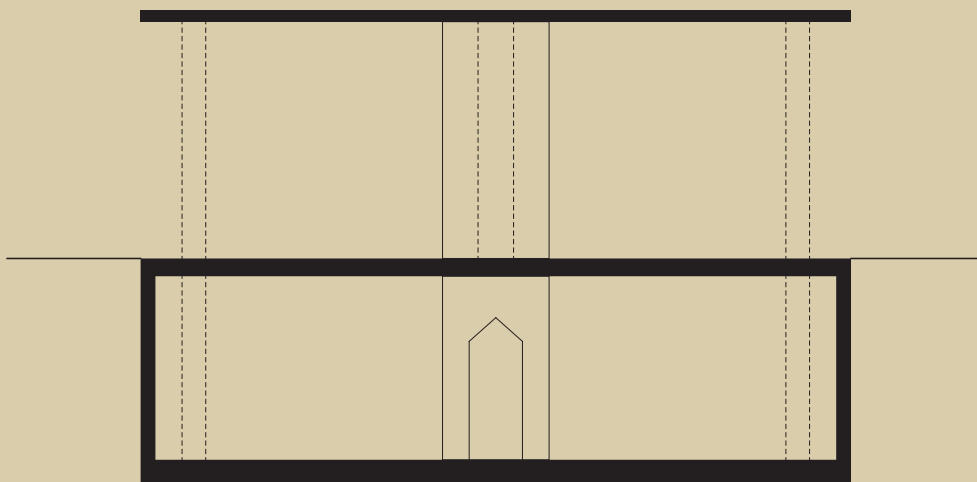

Section

Five columns are placed in the axis of the square plan with one in the center slight larger than the other three but one on the edge trigger the contradiction as being the largest columns in the space but not positioned in the mid

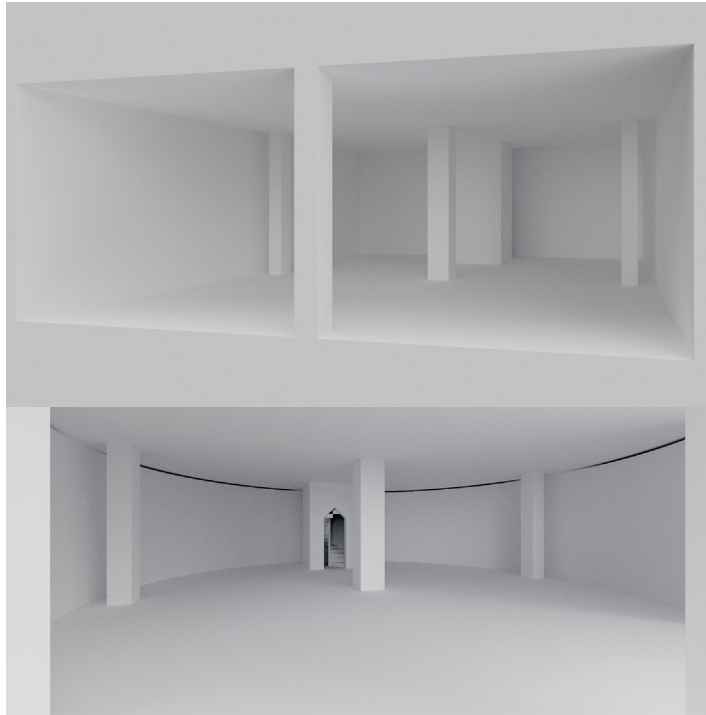

Enter the space with a question that the largest column is not positioned in the mid, walking towards the column and seeing the entrance leading to space behind.

Going down through the staircase, a hidden basement shows up with complete different spatial experiences, enclosed by the curved wall, contradicting the open and square upper ground floor.

The contradiction is embedded between the previous experience and practical recognition.

3

A space with two cross over-lapping beams



A space divided by Beams

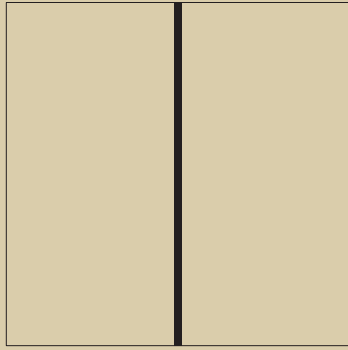

Space is divided by the floating beam that exists as a wall with 600mm gap above the ground

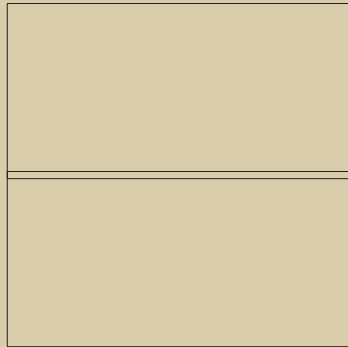

Space is divided by the beam sticking out from the slab with no access to the other side due to the position of the "wall"

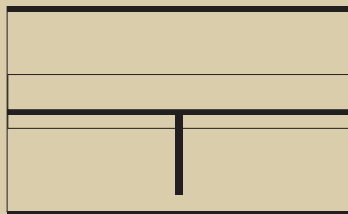

The floors are divided and defined by the two over-lapping beams that exist and precived as "walls" in space

Prototype

A space with two cross over-lapping beams

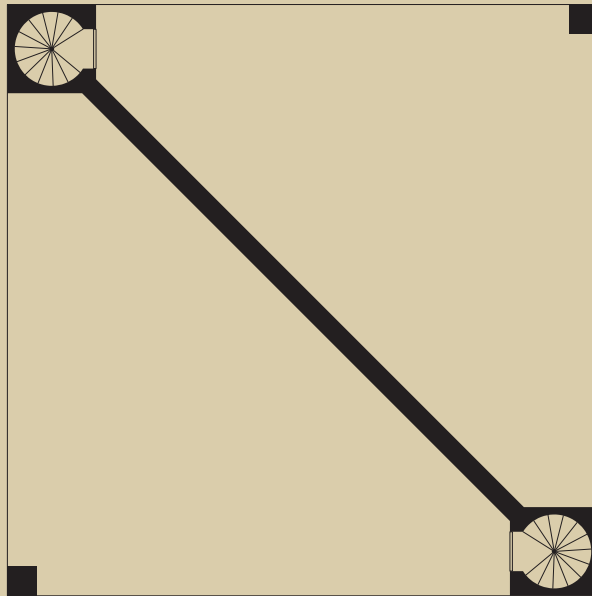

Ground floor

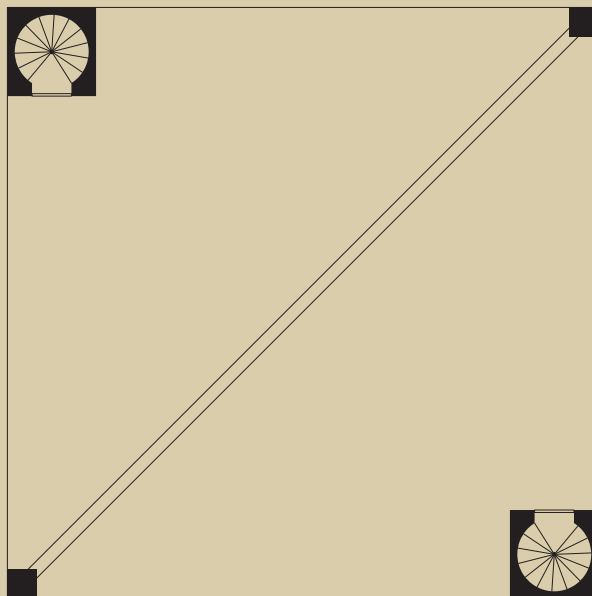

First floor

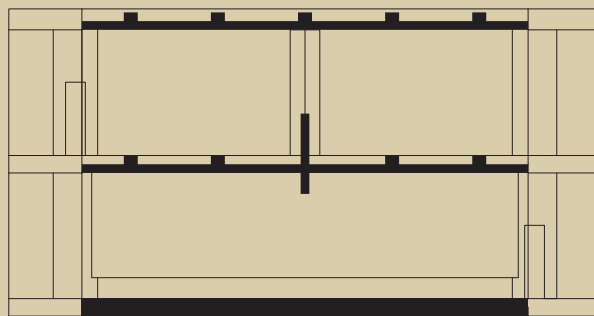
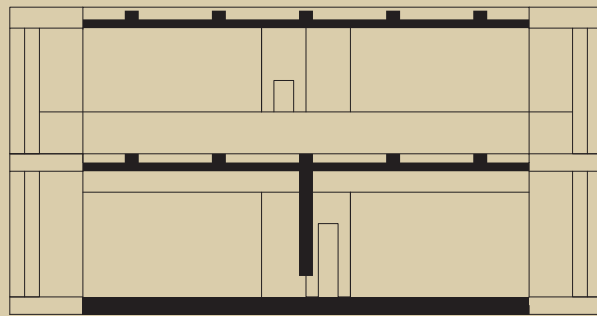

Section

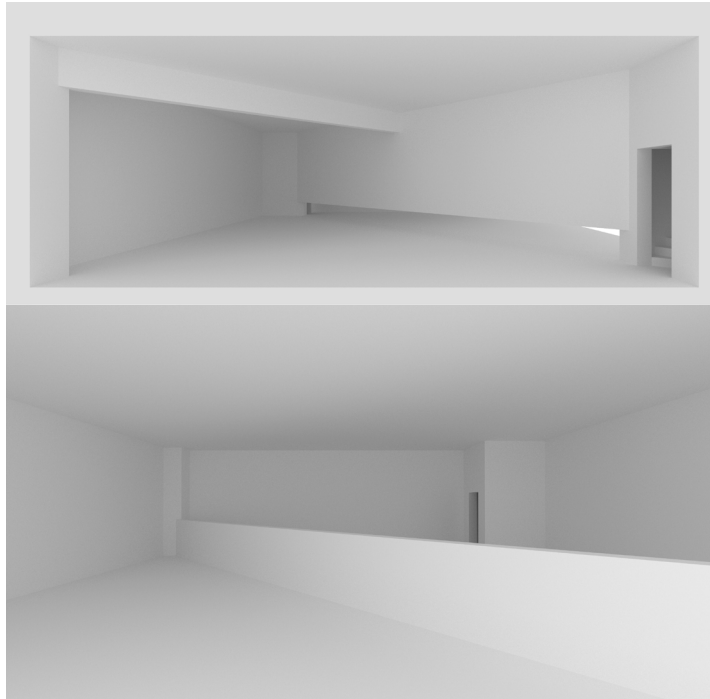

Entering the room with a floating wall standing in the middle and dividing the space, which triggers the question of the physical essence of the wall, looking up to the overlapping beam on top of it, a role of wall starting shifting into a massive beam that gradually becomes stronger thanks to the 600mm gap between the floor and wall.

Going up to the first floor, a wall with 1.2m height divides space and users have no access to the other part, the Alienation among the walls and beams trigger this contradiction of previous recognition and should be experienced in a holistic approach.

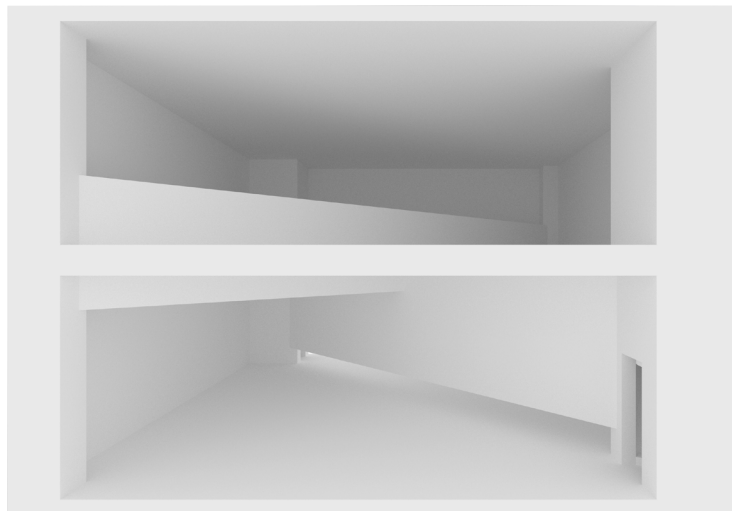

The contradiction lies in the dynamic alienation between the essence of beams and walls, which gives the richness and diversity to the spatial experience.

The contradiction is embedded between the experience and abnormality.

02

Complexity

Less is More

-Mies Van Der Rohe

Less is a Bore

-Robert Venturi

"Less" is by no means simple, but precise and concise space and form obtained through complex, highly-abstract and rational analysis.

"More" refers to the rich and complex form of space in architecture, or the richness of the detail that can be seen through different senses such as sight, sound, taste, touch, smell from space, form, scale, atmosphere. If this spatial experience and perception are intriguing, it is complex and rich knowledge. Conversely, if it is clear and pale, it is simple and boring.

Gestalt Psychology's research believes that people's perception of simple things is relatively easy, and it is easy to obtain a relaxed and comfortable feeling, which, however, is relatively light. While, It 's more difficult to perceive the complex which might evoke a sense of tension, and it is necessary to carry out positive consciousness. But once completed and the tension is gone, people will get more aesthetic satisfaction. Overall, complex stimulation often leaves a deep impression on people.

Complexity in Space

Skeleton



House in a Curved Road, Kazuo Shinohara, Tokyo, 1969

Every building has a load-bearing system, but the majority serve the space as an invisible object behind. The space definition describes a room or a group of connected rooms where the supporting structure remains visible, the elements defining the space coincide with the structure, and pass through space horizontally and vertically, regardless of how space is separated. The decisive factor is that the structural elements maintain the integrity of the space, although they may not limit the space themselves, they still shape the perception of space, making structure and space as oneness.

Domino structure system

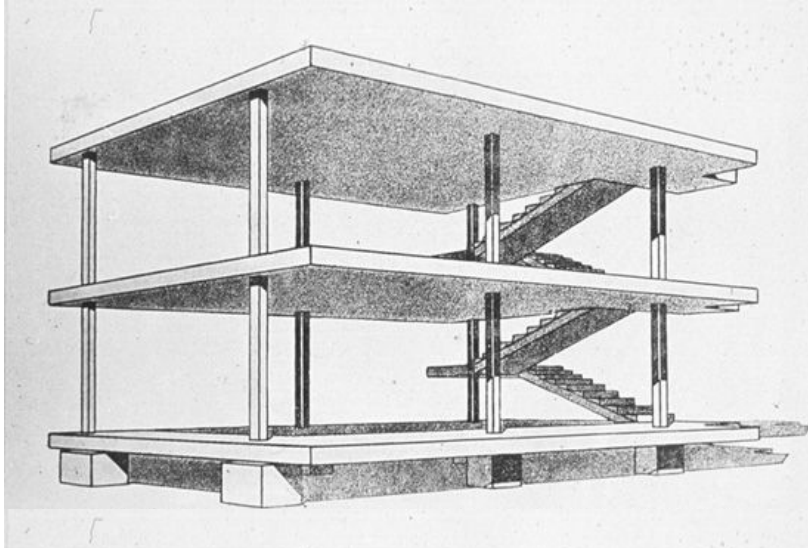

Dom-ino House by Le Corbusier, 1914-1915



Although not particularly stunning in the visual sense, the domino house was significant because it sparked the entire prefabricated house movement. The simplicity of design meant that the building could be replicated easily, two levels connected by a simple staircase. The steel frame meant that no load-bearing walls obstructed the living spaces, allowing the interiors to be laid out however the owners desired.

Clomun

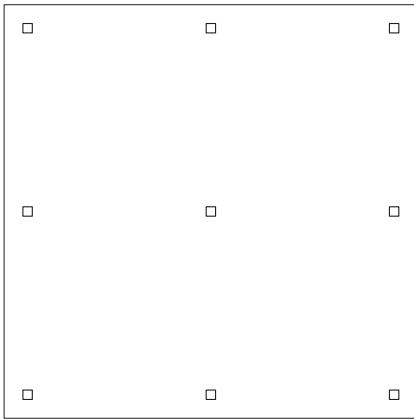

Wall

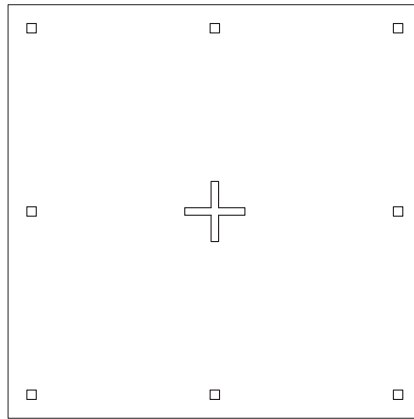

Core

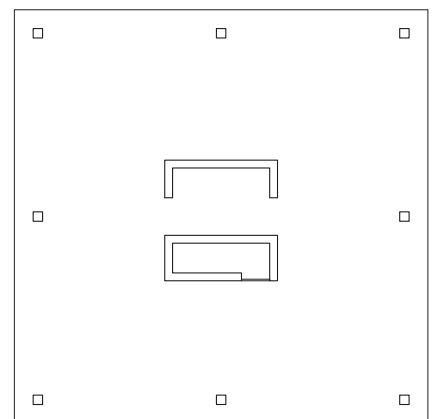
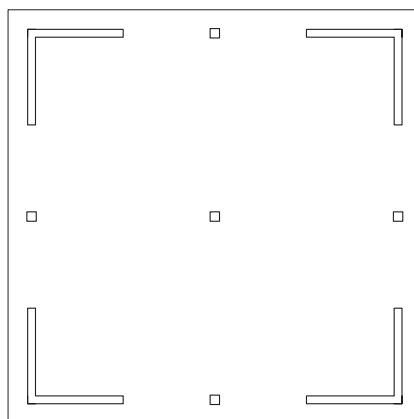
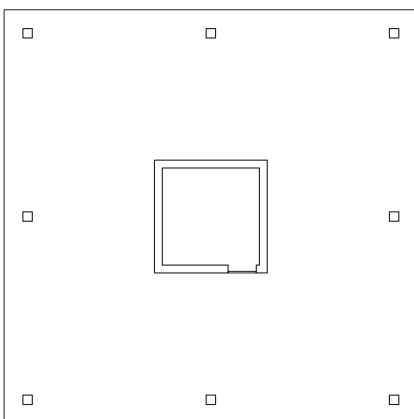
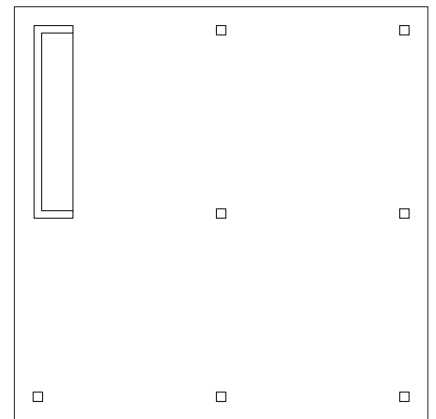
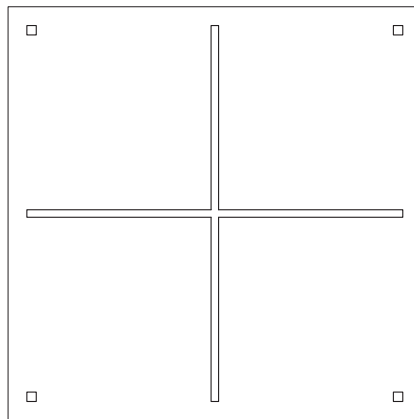
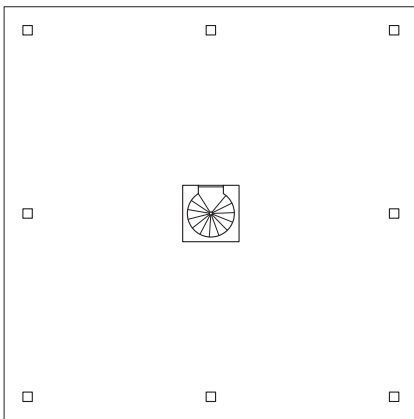
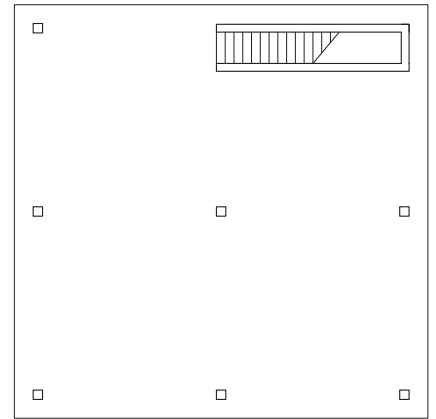

Enlarging the dimension of the column creates a spatial skeleton with an extension as well as a hierarchy in the space.

Replacing the columns with load-bearing walls defines the division and enclosure in the spatial sequence.

The core brings richness and diversity in the domino structure system, extending the spatial sequence.

Skeleton

A space defined by skeleton



A space defined by skeleton



Prototype-Simplicity

The space is defined and supported by the four columns ,with hierarchy intergred in the diemension out of cantilevering slab,functional,simple and effective,creating a free plan layout.

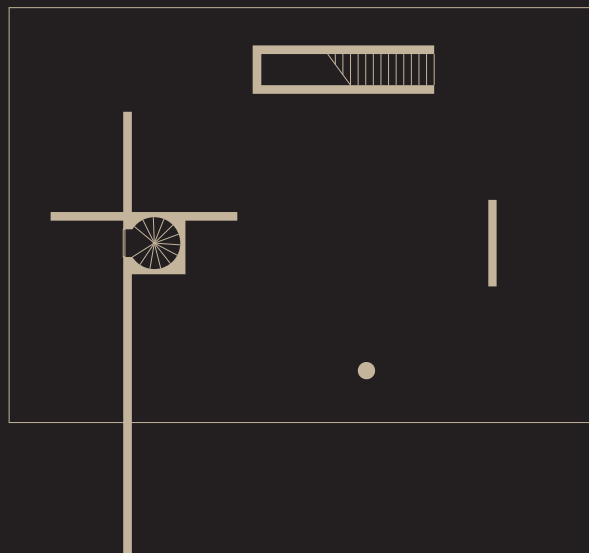

Skeleton-Complexity

The space is characterized by a long wall dividing the plan into two distinct areas.The structure consists of a long wall combining a core with a staircase leading to the basement, a column, one short wall and a direct stair, which together form a totality of the skeleton. By synthesizing the structure and the interiors three very different worlds are created in extremely minimal space.

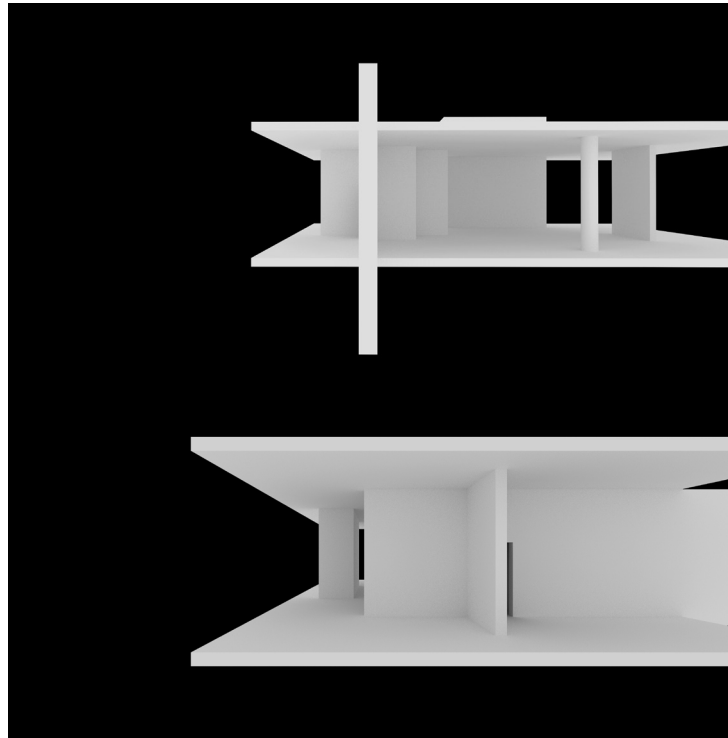

The entrance is guided by a sticking-out wall that divides space into narrow and open parts.

Two staircase cores are placed as a skeleton and lead to space below and above.

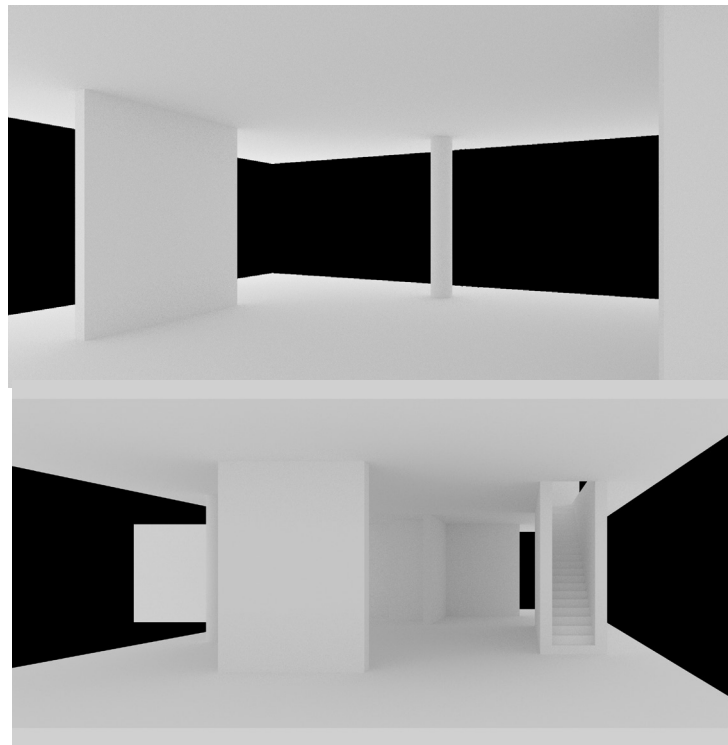

The skeleton initially develop from the domino structure system and turn into wall,round colum as well as cores.The complexity of the skeleton gives the richness,diversity as well as divided spatial sequence to the spatial experience.

Complexity in Space

Dimension



Paspels school, Valerio Olgiati, 1998

The dimension of positive spaces can remain spatially connected and related to negative spaces, while independent positive spaces unnecessarily have to be connected, thus creating a spatial sequence to perceive them as objectives instead of just unclear room behind the walls. But if the space between rooms is as clear and defined as the positive space, then the spatial sequence loses its dualistic and hierarchical layers, and the concept of "Dimension" loses its meaning.

The internal wall of the Paspels school has a slight deviation in the horizontal direction. This deviation makes the room's static system perform an undetected "movement", adding a "sense of space", while the outside "physical feeling" strengthened the independent and tightly engaged spatial experience.

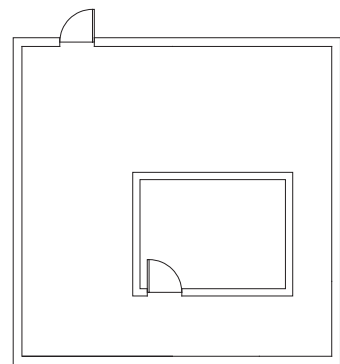
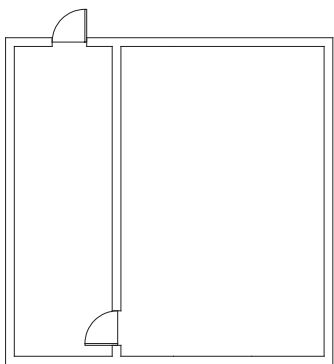
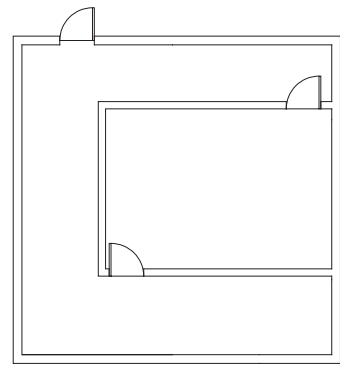
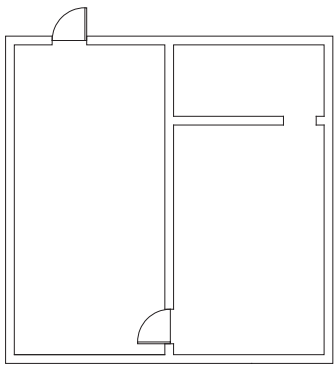
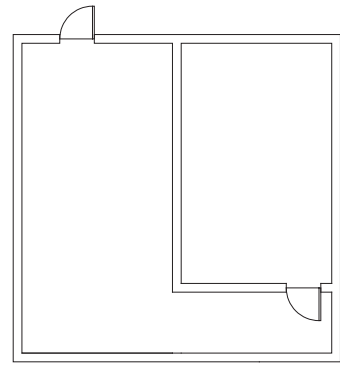
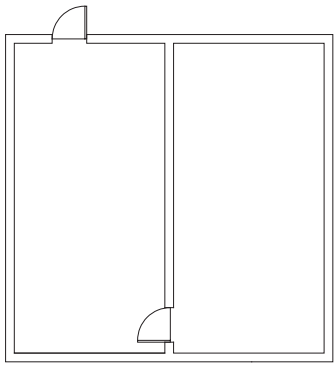

The spatial dimension of the positive space can not be perceived with one side from the negative space connected ,including the subdivision of the positive space,thus losing the duality of space

With more than two sides of positive space connected to negative space, the physical sense of space gradually becomes more clear and richness is spatially defined and created.

Dimension

A space with different thickness of walls



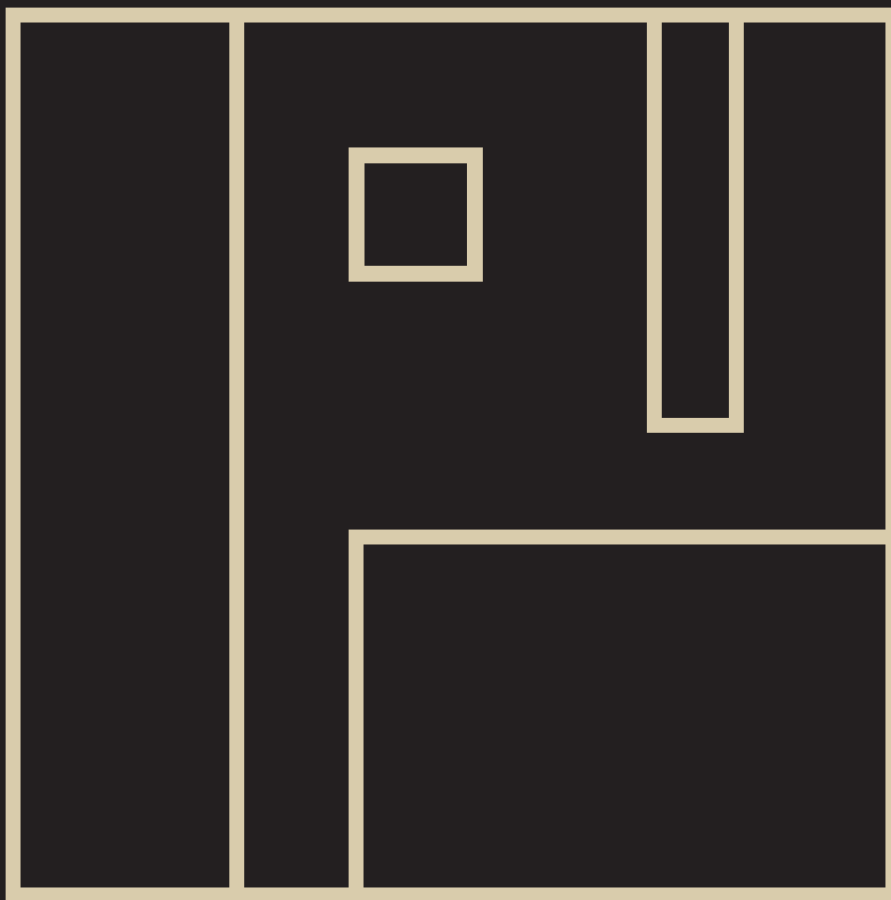

Prototype

A space with different thickness of walls

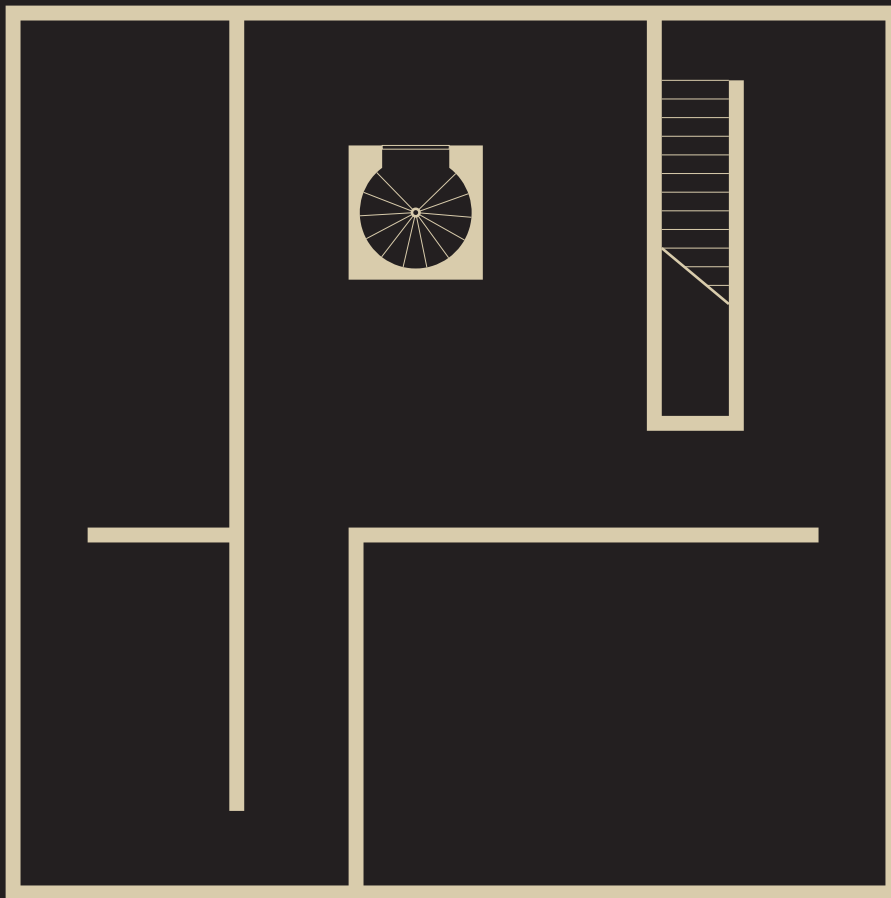

The spatial experience of thickness of walls is to perceive the physical volume and dimension as well as static sense of positive space through dynamic approaches.

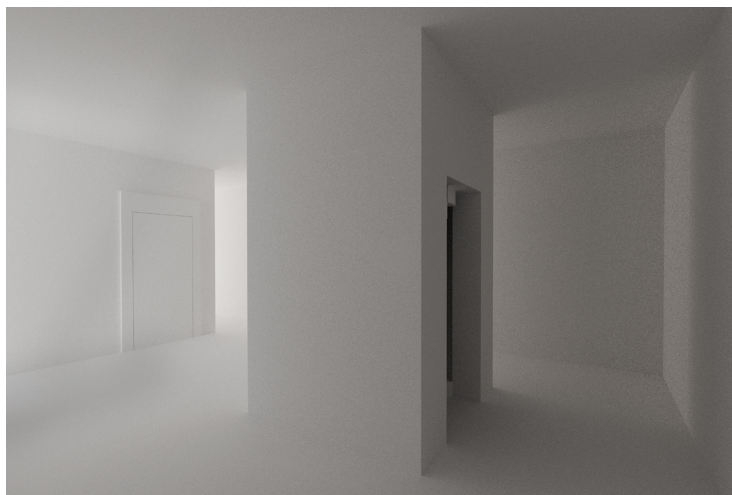
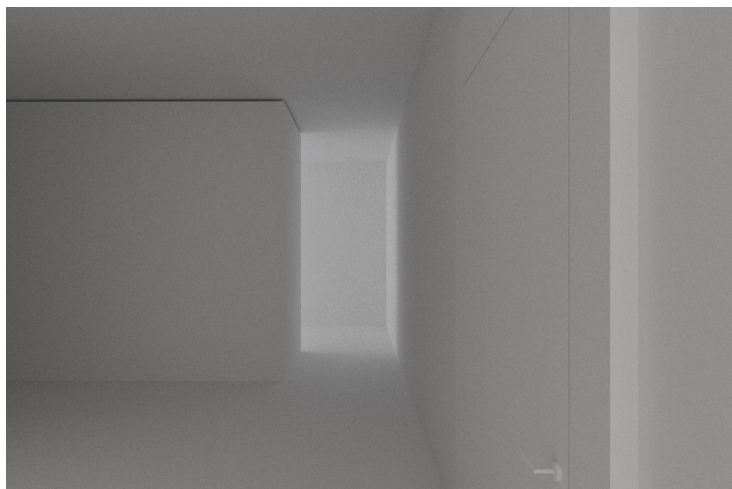
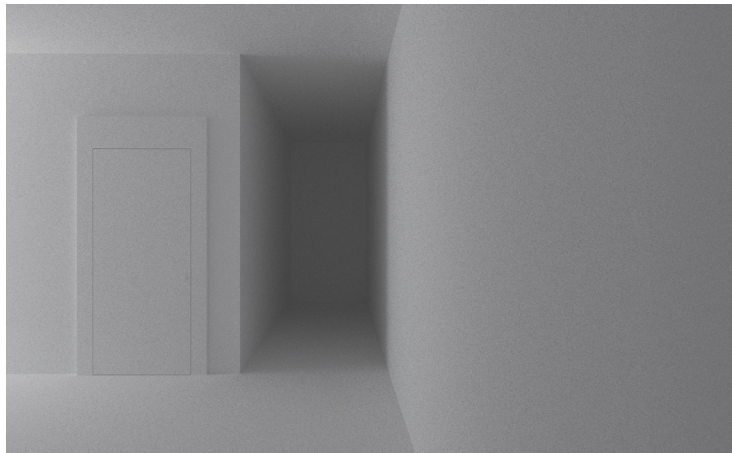

The internal walls of the positive space have various closure in the horizontal direction with a different number of sides. This deviation makes the room's static system perform an undetected "movement", adding a "sense of space".

Complexity in Space

Division



Barcelona Pavilion, Mies van der Rohe, 1929

Not every wall or column divides a space. In fact, most of the walls are combined together with no intention of letting the space experiences communicate with each other. If a room can be clearly and uniquely experienced as space, then walls can only divide the room. In addition to clear geometric or sensory boundaries, architecture can also be used to emphasize the spatial context beyond its division. Although space is divided, it can also be perceived as a single holistic space.

Column

House in Uehara, Kazuo Shinohara, 1976

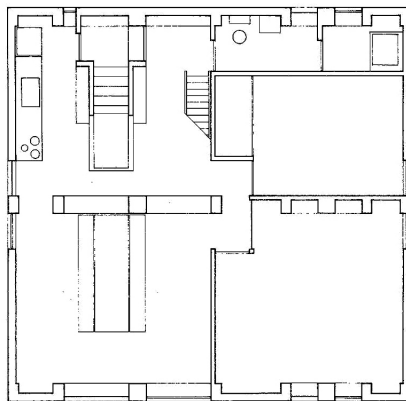

The first floor is the parking space and the studio, the second floor is the living room, and the second floor is cut off at the entrance staircase. As a result, the columns of the naked tree structure appear. At the same time, the structure also divides a living room and a kitchen. The meaning of division transcends the structure itself, meeting the requirement of its use function in the house as well as achieving a balanced existence in conflict with each other.

Closure

Space(room) is defined and limited by the position of the columns placed in the corner

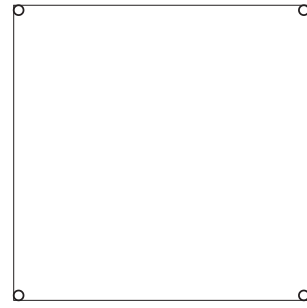

Openness

The boundary of the space is not defined and restricted by the columns with a possibility of spatial extension.

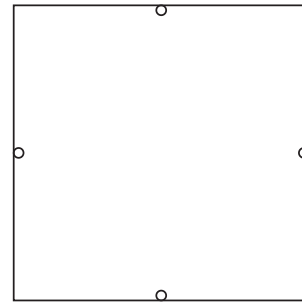

Centralization

Monumentality is created by the centralized position of the column and space is equally divided.

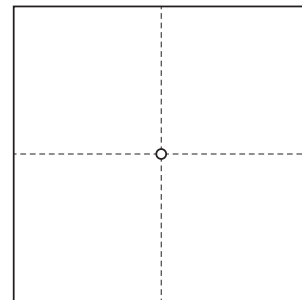

Deviation&Unequalness

Spatial unequalness is defined by the deviated column thus creating the hierarchy in the space

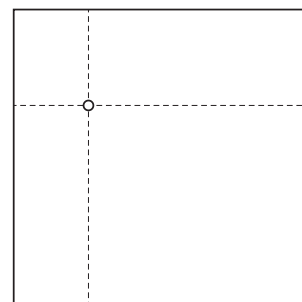

Compression

The diagonal column plays a role between vertical column and horizontal wall, compressing the spatial division.

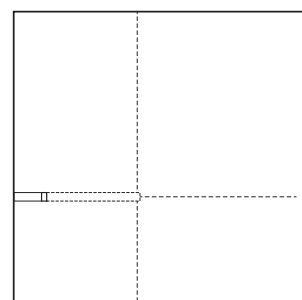

2

Wall



Apartment Building on Forsterstrasse, Christian Kerez, 2003

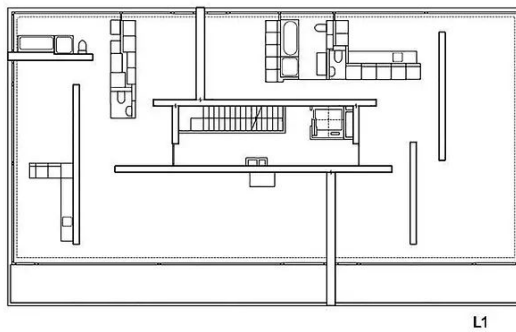

The interior of Kerez's own house is an open layout architecture. It is divided into load-bearing walls and there is no hierarchical distinction between different functional rooms. Open and closed, heavy and light spaces merge into an indivisible whole. They are interdependent and are different manifestations of a conceptual single and holistic space.

Warping

Space(room) is defined and limited by the position of the shear walls .

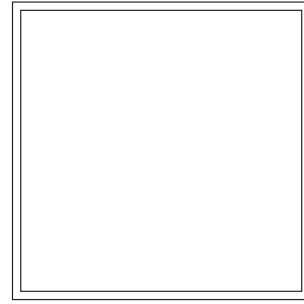

Openness

The boundary of the space is not defined and restricted by the shear walls with a possibility of spatial extension.

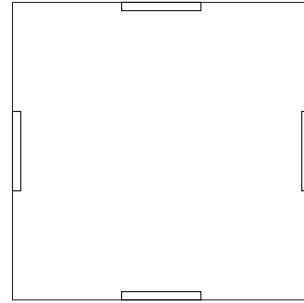

Centralization

Equality is created by the centralized position of the shear walls and space is equally divided and connected.

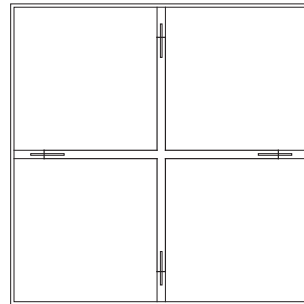

Holism

Various walls should be viewed as wholes in a holistic approach, not merely as a collection of parts, unequally dividing space.

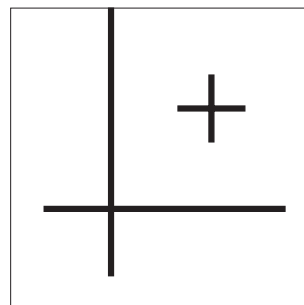

Tilt

Unequalness and dynamic of spatial division are raised by the tilted wall that originates from the midpoint of the floor, compressed and enlarged.

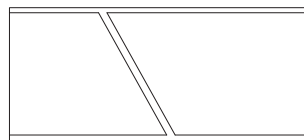

3

Slab



House NA / Sou Fujimoto

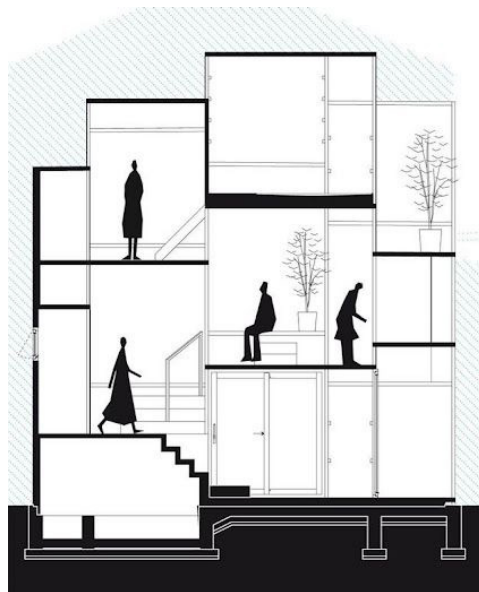

House NA has three storeys that are subdivided into many staggered platforms in different levels divided by floor plates, in which these are some of the moments of richness encountered through such spatially dense living.

Compression

With the different positions of slabs, space is compressed and spatially connected by the steps, creating a certain hierarchy and sequence for space.

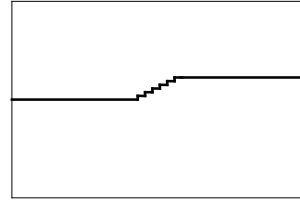

Extension

Space is vertically divided by the slabs with the extension of creating double-high space or even more.

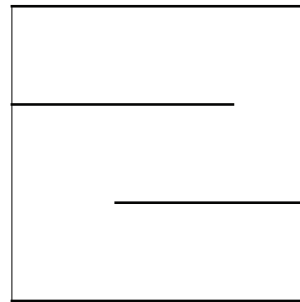

Fluidity

With curved slabs positioned above the ground, the slopes and curves define the interior space and give a completely different spatial experience on and underneath the slabs.



Variation

With a twist force embed in the wall, it turns horizontal division into vertical division, creating a more open space for the following spatial sequence.

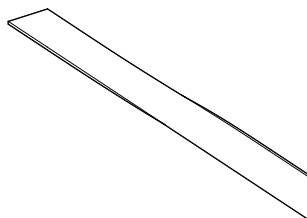

Division

A space defined by skeleton



A space with hidden double high floor

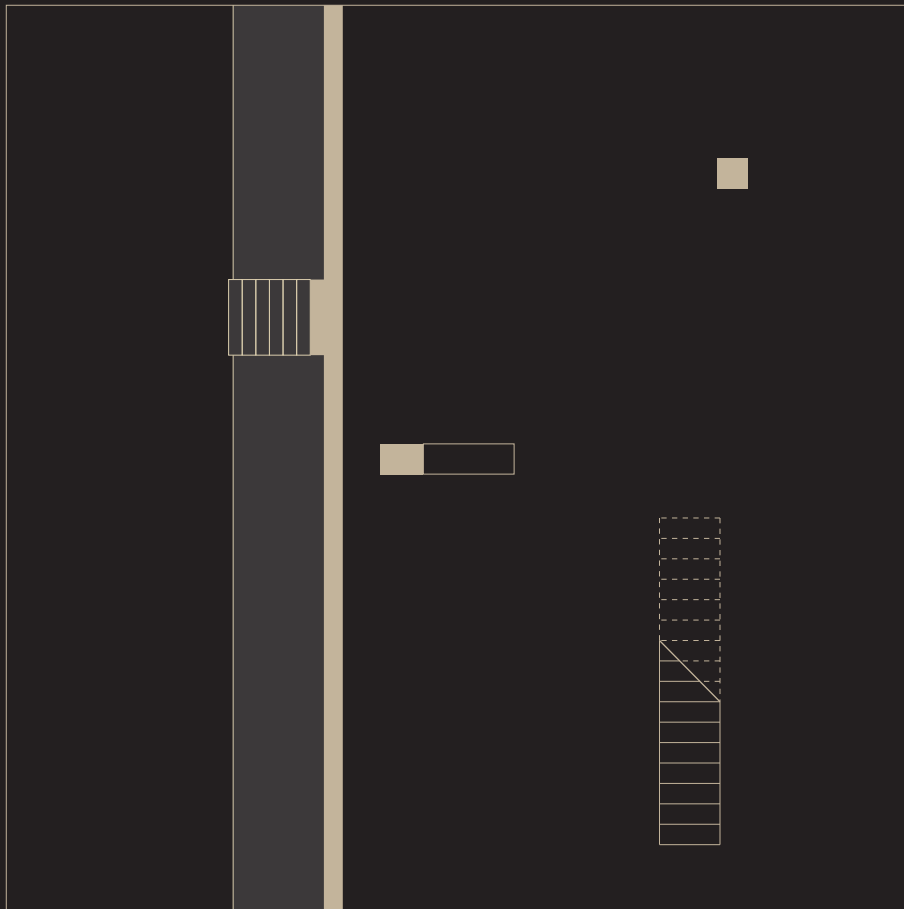

Ground floor

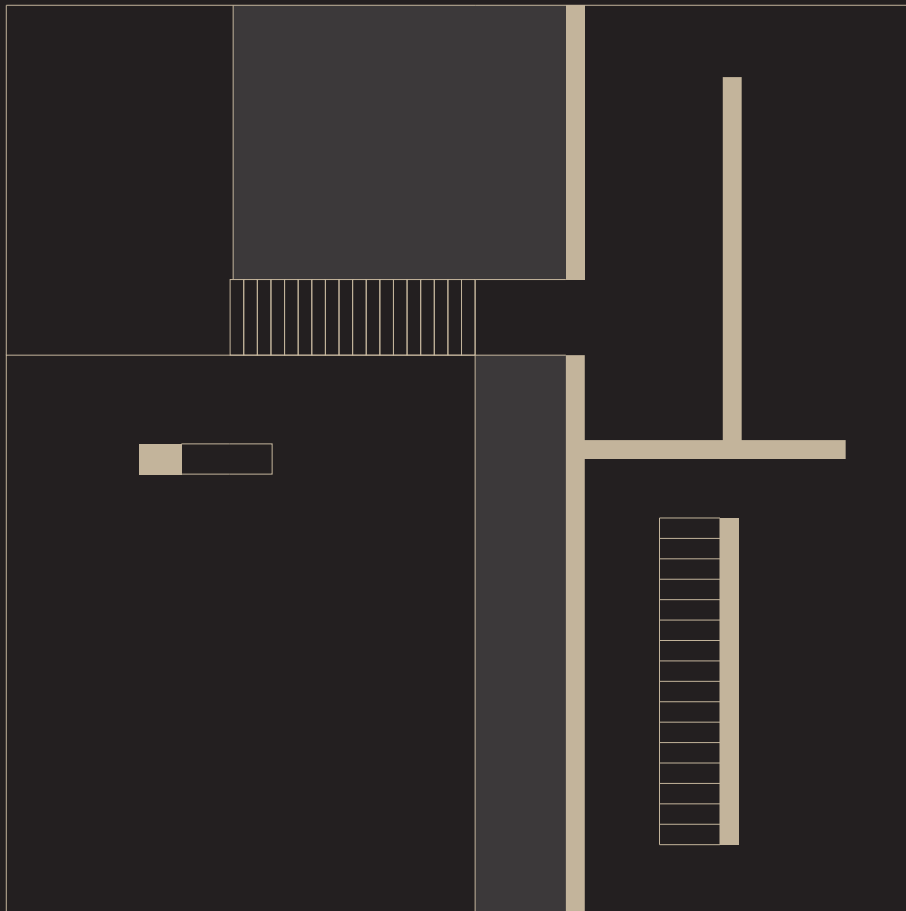

First floor

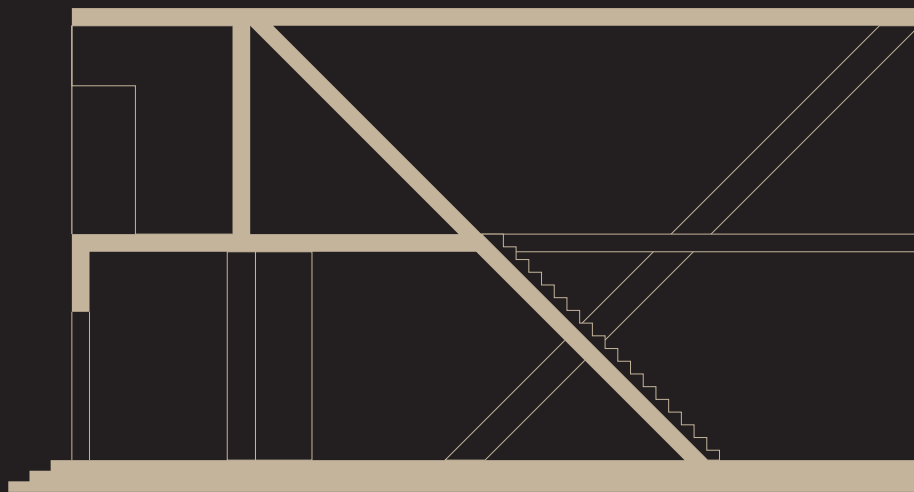

Section

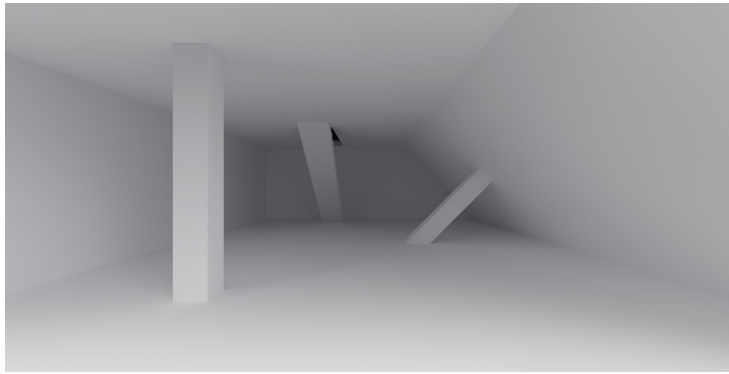

Column

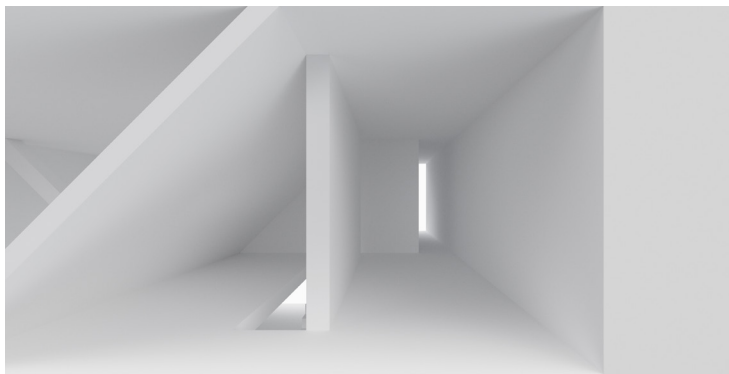

Wall

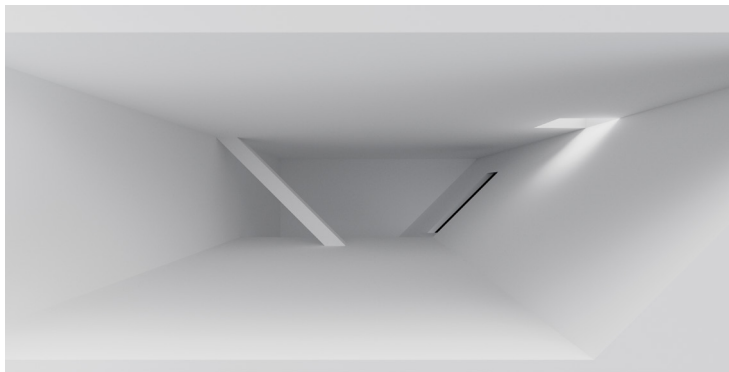

Slab

The ground floor space is divided by a tilted wall in the middle, compressing the space defined and divided by a vertical column as well as a partly tilted column sticking out the wall, with a staircase indicating the space above.

Going up to the first floor, a shift from the Column-dividing space into wall-dividing space gives certain privacy compared to the open ground floor.

After passing the door leading to the double-high floor, space is divided by the slab growing out of the tilted wall and the slab is also cut by the tilted column, in which all the space-dividing components merge into a holistic division.

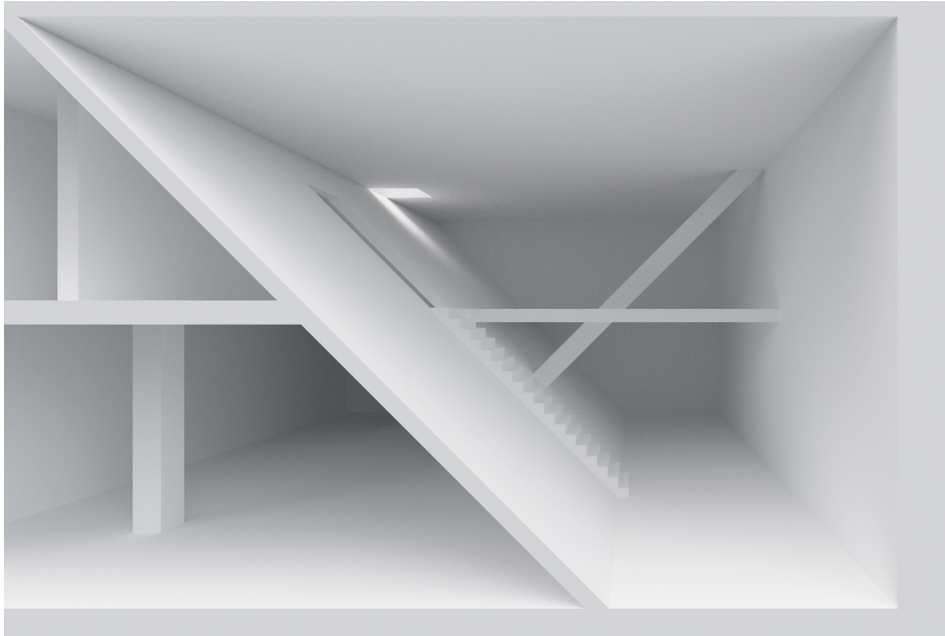

Double-height space

The light from the sky window strengthens the materiality of the tilted partition wall, and a hidden double-height floor intends to elaborate space with division by columns, walls, as well as slabs and how space could be recognized through a holistic approach.

03

Prister' House with a hidden Cemetery Garden

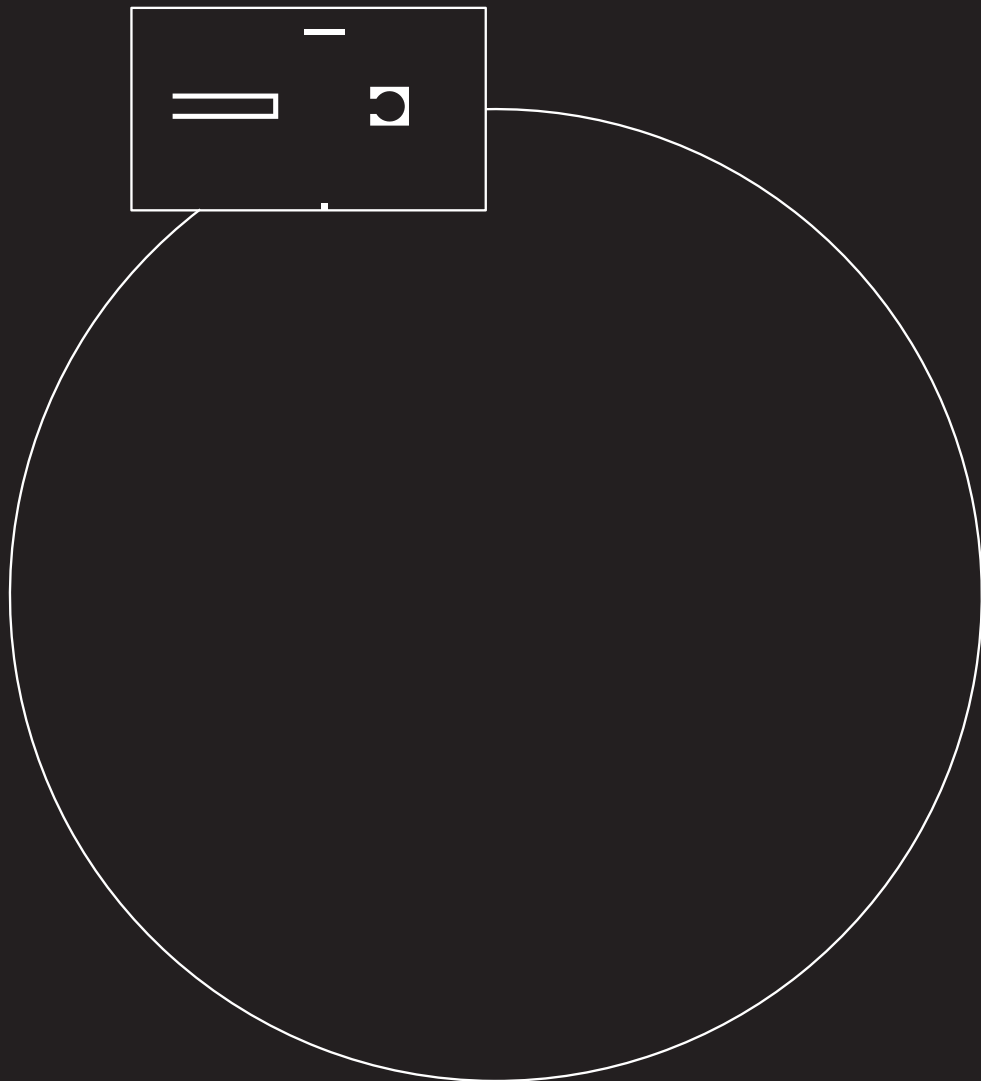

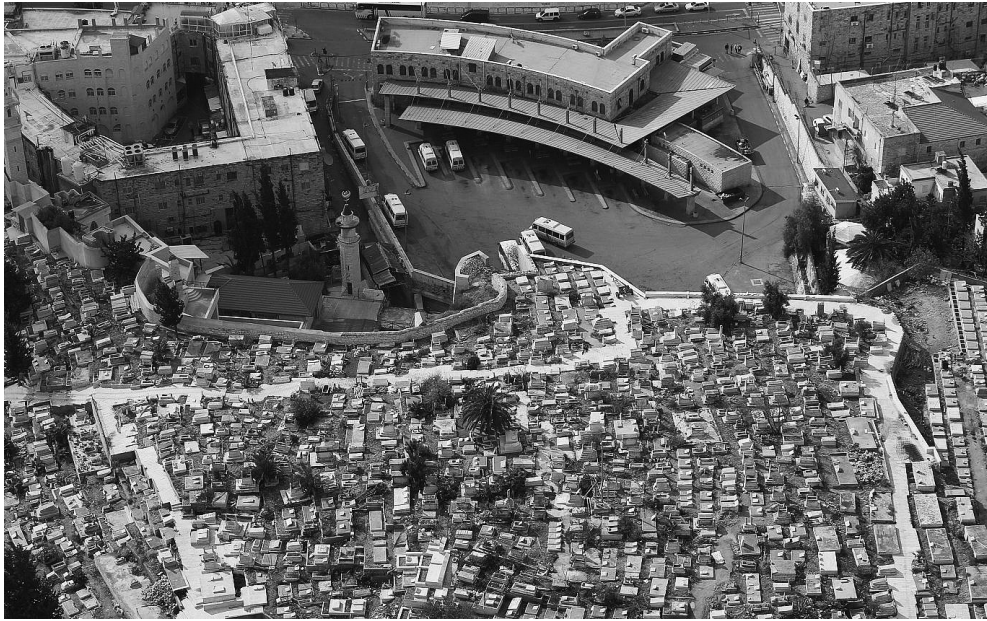

An areal view of a Muslim cemetery in East Jerusalem,

The city is the residence of the living,

The cemetery is the city of the dead.

DEATH

A person will experience death three times in his/her life. The first time is the moment when stop breathing, from a biological perspective. The second time is when the funeral is held, at this moment your identity as a citizen will be eliminated in this society. The third time is the moment when the last person in the world who remembers you passed away, and this moment would be the real death. Since then, no one on this planet will know you afterward that you have been to this beautiful world for a period of time in long human history.

LIFE

The cemetery was not built for the dead, but for the living. The value of the existence of the cemetery is not for the dead in need a space to store the urns, but the living needs a memorial for the dead and needs spiritual comfort space. In essence, the cemetery only provides a medium for people to miss, and the existence of cemetery is not due to the eternity obtained by its own architectural form or materiality, but people's belief in Life.

After the process of reference study and iterations in the early phase, I did not intentionally look for the site of **weak context** to express the architectural form of the independent cemetery building. Instead, I intended to find a site that can reflect the spirit of the place, that is, to illustrate the **existing contradictions and complexity** of the site, after in-depth research, and integrated it in the design project, then proposed a geometric figure that emphasizes the monument .

Secondly, try to refine and simplify the a **prototypical space** of the surrounding areas, through relying on "matter is spatially concreteized", thereby linking "**landscape as monument**" with the design project (**Building as monument** in the landscape) to create a balance between site specificity and architectural autonomy. The contradiction and complexity of the landscape are reflected and integrated in architectural spaces.

I hope it is also a architectural combination of **abstraction** and **figuration**. The functional space is figurative, meanwhile the graveyard is abstract. Part of it belongs to the existing landscape (the extension of the cemetery landscape), a place where emotions are placed; On the other hand, it belongs to architecture, but it is closer to the nature than any spaces. These contradictions and complexity are intended actions.



Context

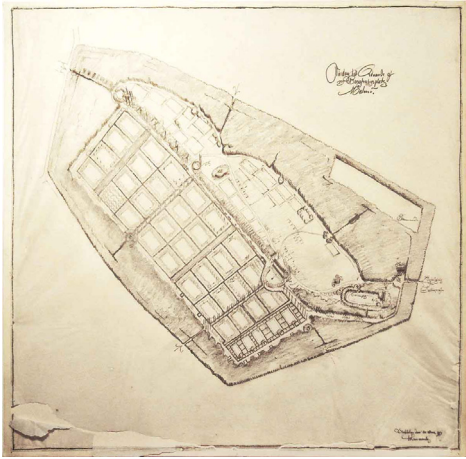

Master plan of Malmö eastern cemetery by Sigurd Lewerentz

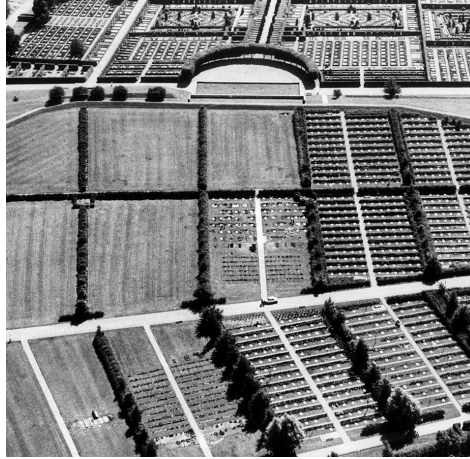

Since the early twentieth century, there had already been much debate in Sweden about what funerary monuments should look like, efforts to legislate burial customs, the reinstated practice of cremation, and the overcrowding of cemeteries in Sweden triggered a series of competitions to develop new cemeteries and fired the debate. Under the motto of Ås, meaning ridge in Swedish, Lewerentz's project was considered head and shoulders above the other entries.

Lewerentz's design for Malmö Eastern Cemetery made considerable use of vegetation, which, in general terms, is planned such that it gives the area an outwardly closed character, confines the different stages of expansion and provides a strong contrast between the open, bare burial land and the closed, planted burial land.

Additionally, the regular height of the hedges screened the intimate spaces of the graveyards, while bestowing a monumental scale to the entire sector, visually unified by the use of beech planting.



The Malmö Eastern Cemetery will probably no longer provide enough space for interfaith use in memory of the dead. The perimeter of the cemetery for public viewings and funeral services was limited by existing lands for graves and urns, and it demands extended ritual spaces together with a suitable atmosphere within the context.

The design proposal consists of a house for a priest with chapel and a hidden round graveyard, which gives an impression of closed character contradicting the open cemetery landscape, and creating a similar spatial experience that follows the spatial sequence of the burial ground defined by vegetation.

Conditional Autonomy

The inside of the graveyard can not interact with the surrounding beautiful natural environment visually or physically, featuring the contradiction between form language and natural landscape by the enclosure of walls, which, however, is corresponding to the enclosure of hedges in the Lewerentz's design for graveyards in cemetery landscape.

Nodes

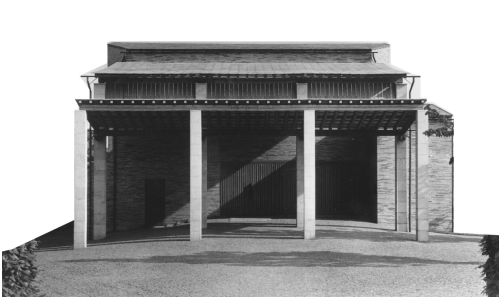
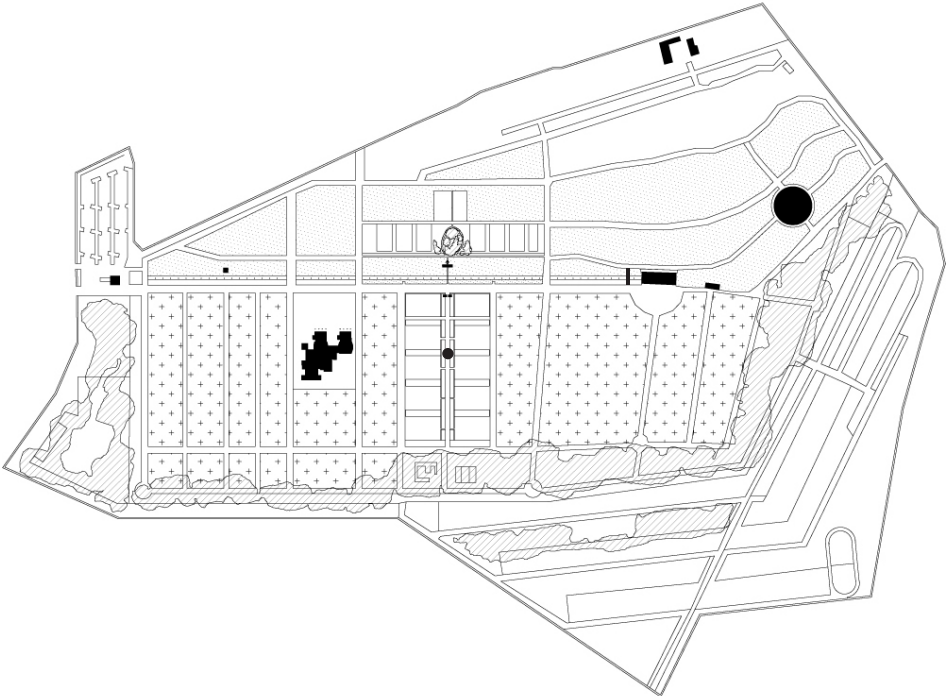

Form Language

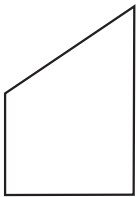

Piched roof

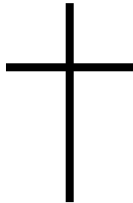
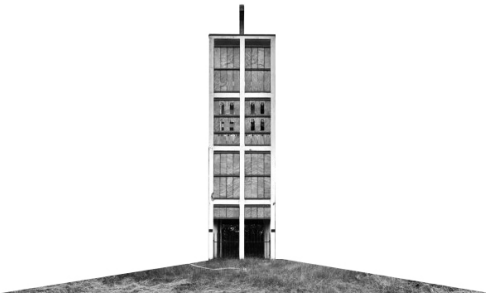

Cross

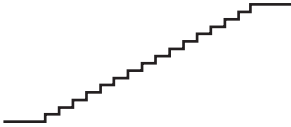

Steps

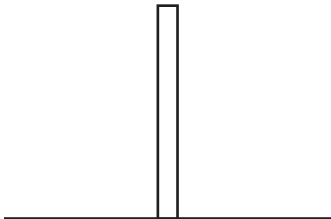

Column

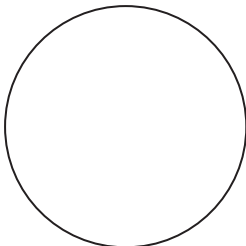

Circle

Prototype



Residential

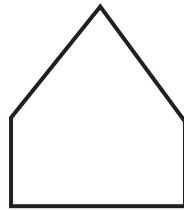

Simplification

+

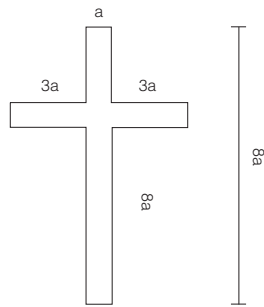

Cross porpotion

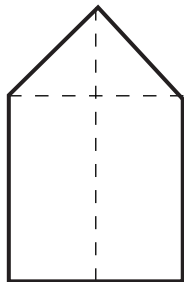

Space Prototype

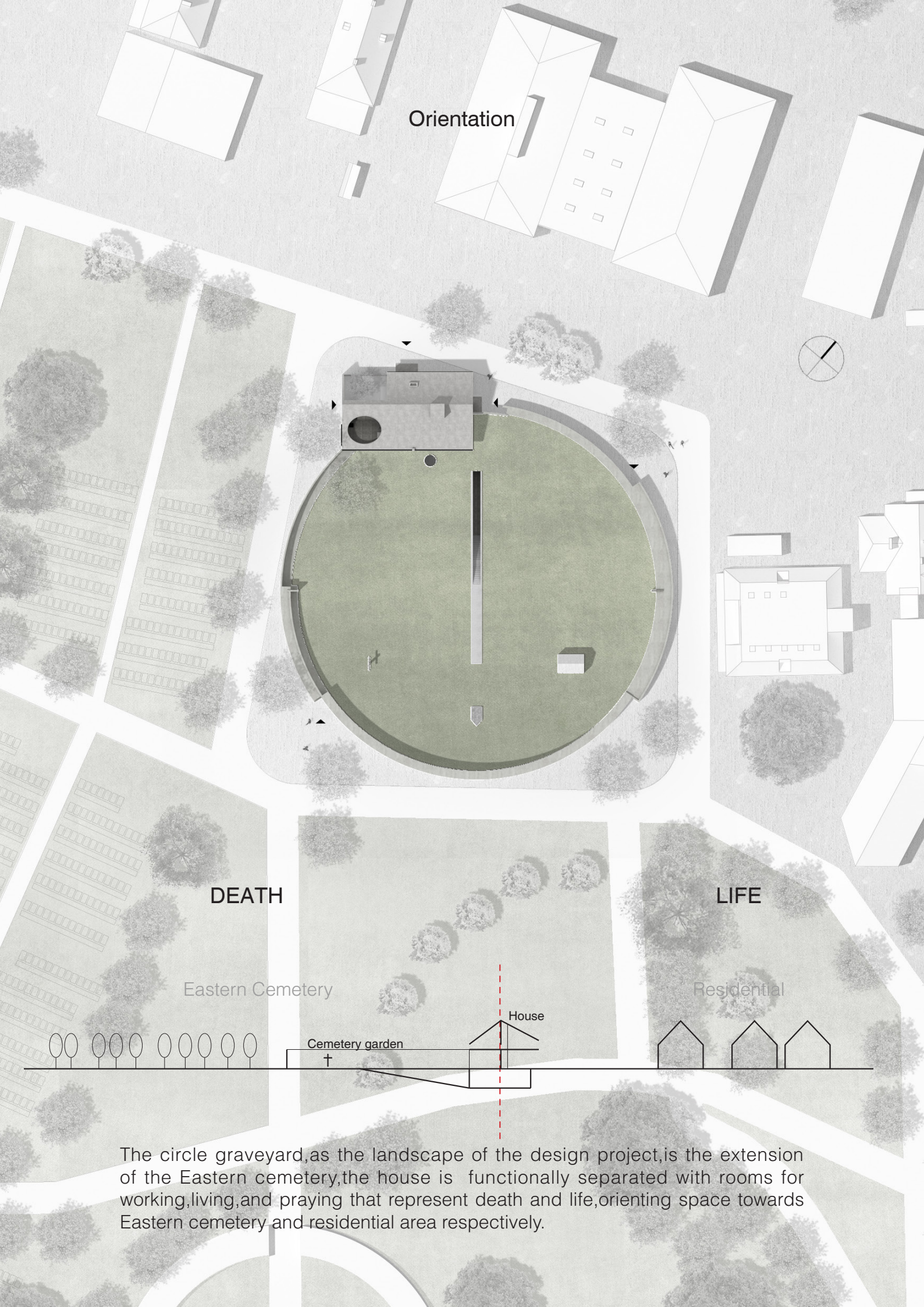

Orientation

DEATH

LIFE

Eastern Cemetery

Residential

House

Cemetery garden

The circle graveyard, as the landscape of the design project, is the extension of the Eastern cemetery, the house is functionally separated with rooms for working, living, and praying that represent death and life, orienting space towards Eastern cemetery and residential area respectively.

Complexity in Space

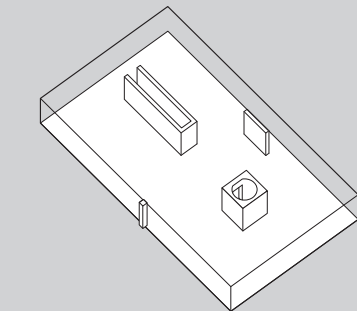
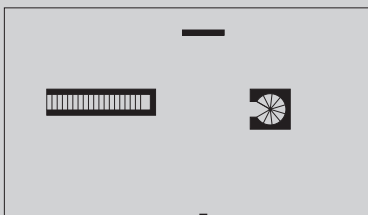
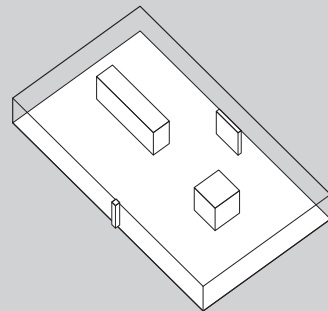
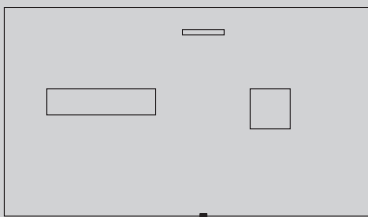
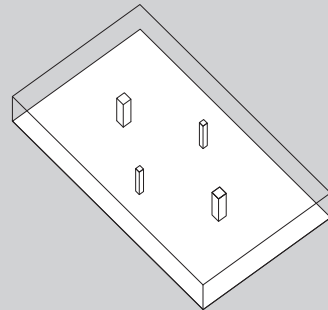
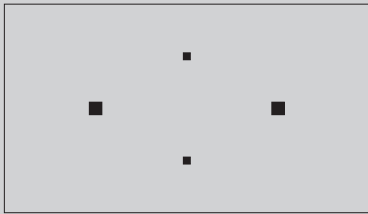
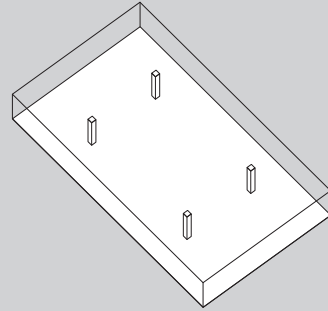
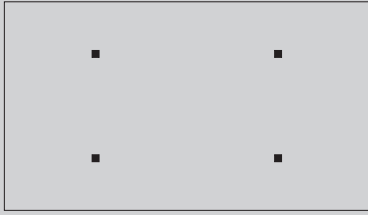

Complexity in Skeleton



The space is supported by the skeleton that also divides space, beams sticking out from the staircase core divide space not just functionally but also spatially separated, more importantly, act as partition walls.

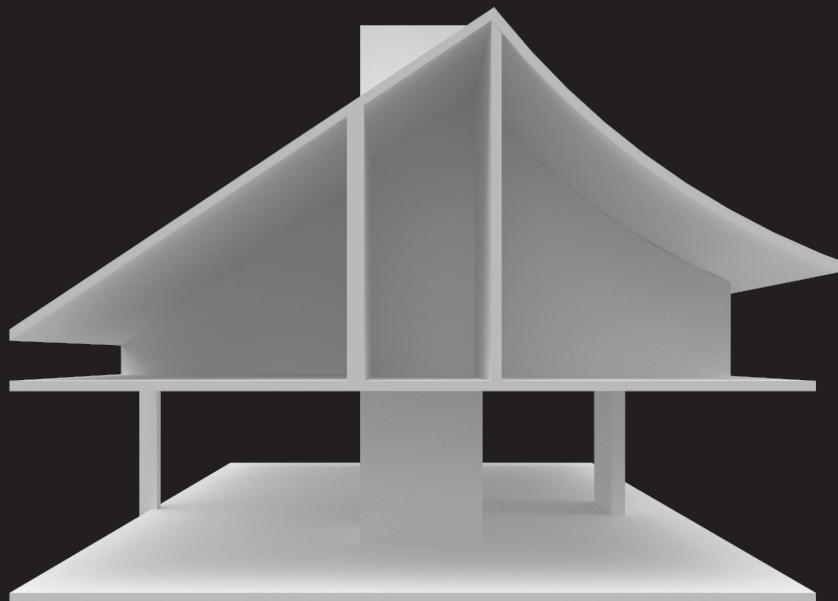

Contradiction in Space-Iteration

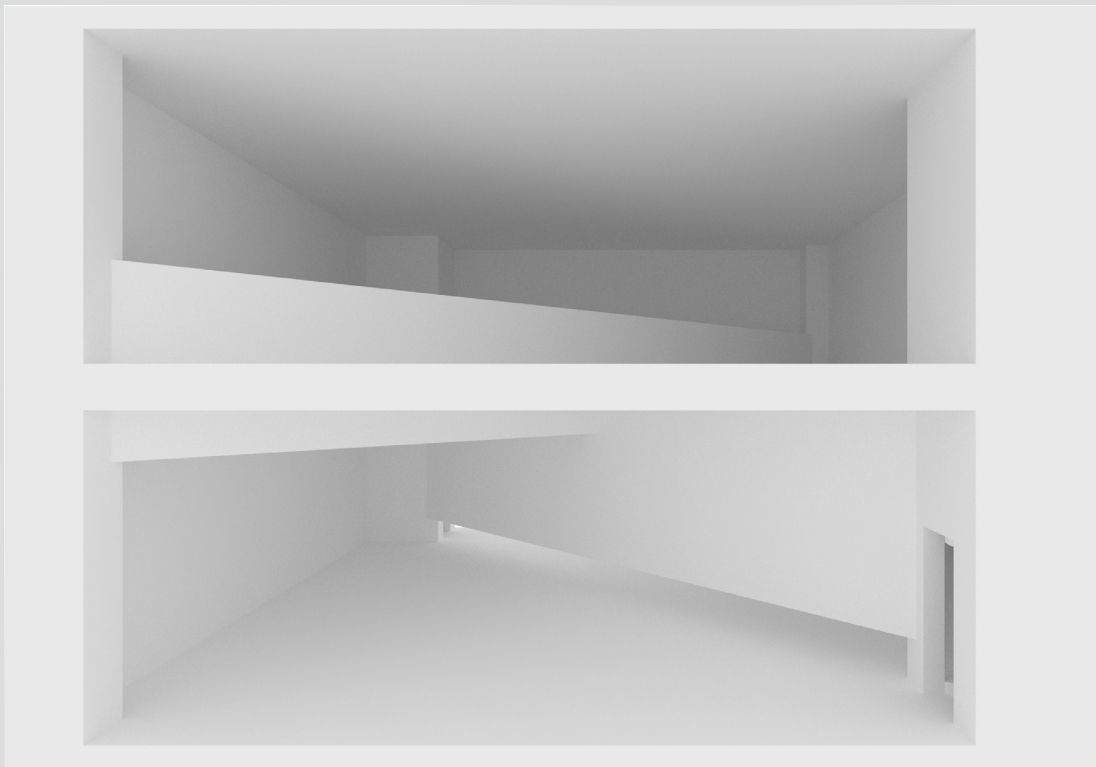

A space with two cross over-lapping beams

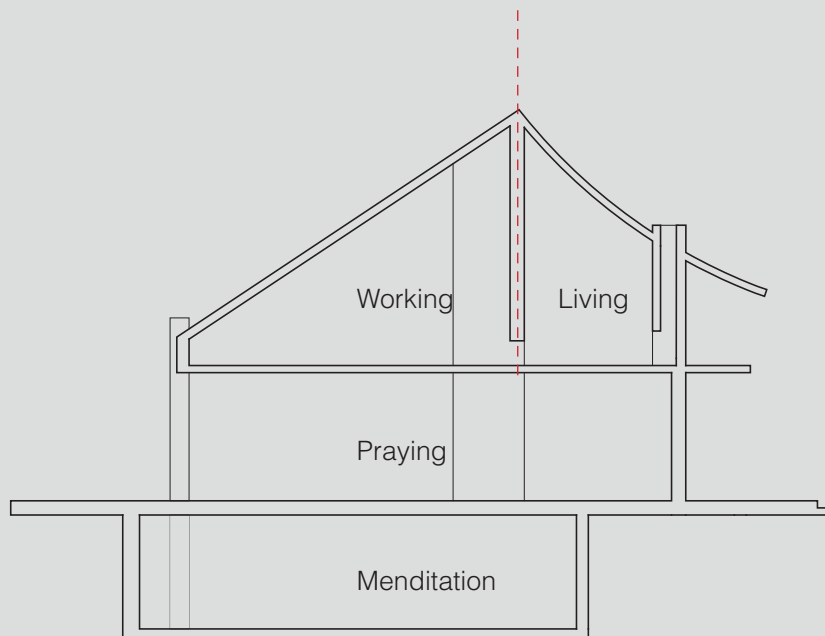

A space separated by a "wall"

Contradiction in Space

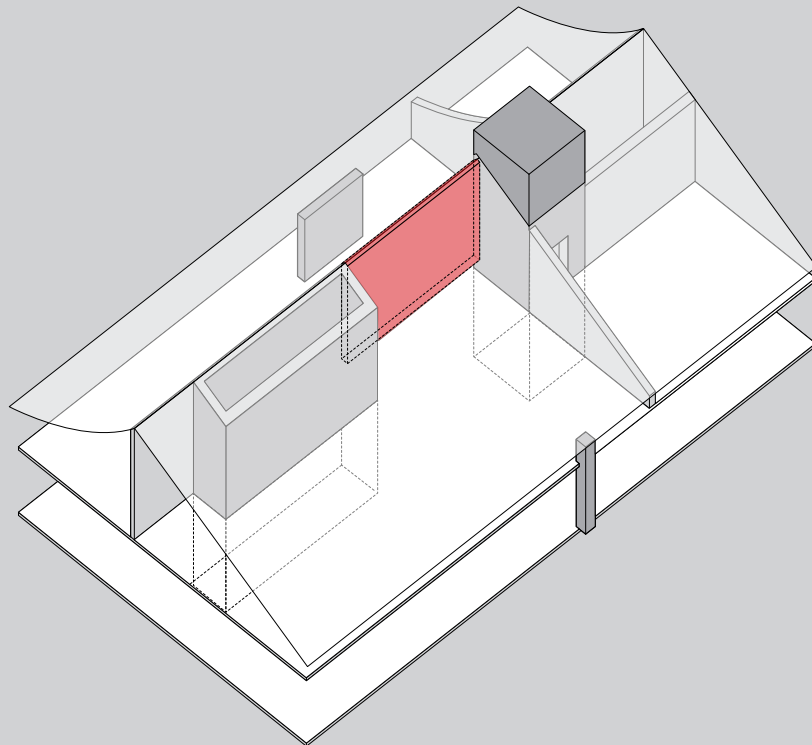

The priest, as a narrator of the house, works for death during the day time but, on the other hand, also lives like ordinary people.

The idea that uses "wall"(beam) as a intervention supported by skeleton divides space with different function while remaining spatially connected with no access to each other, creating a clear spatial sequence in which the user has to go down through the staircase case first, thus triggering a unique spatial experience that the priest will go through a role-shifting process, from working to living, from death to life.

Contradiction in space

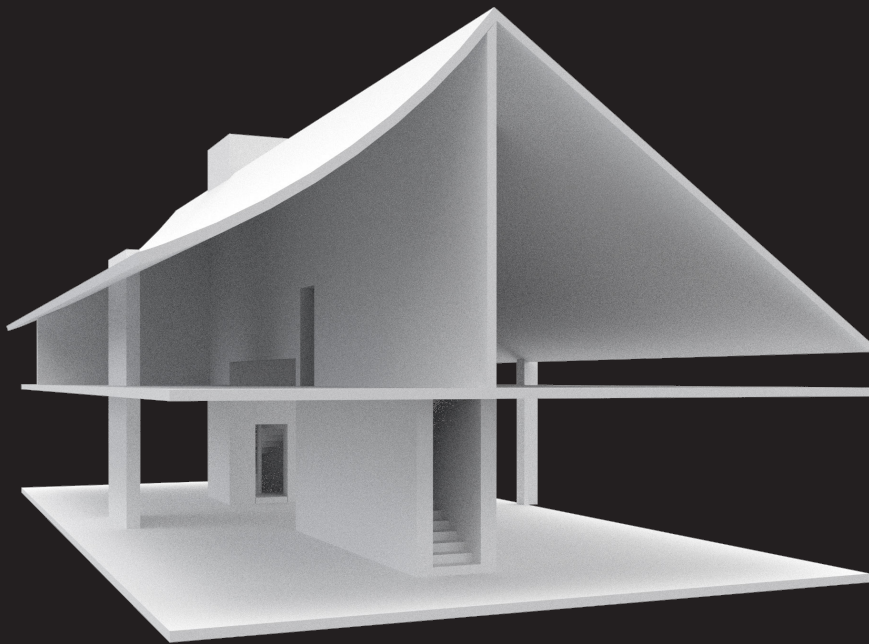
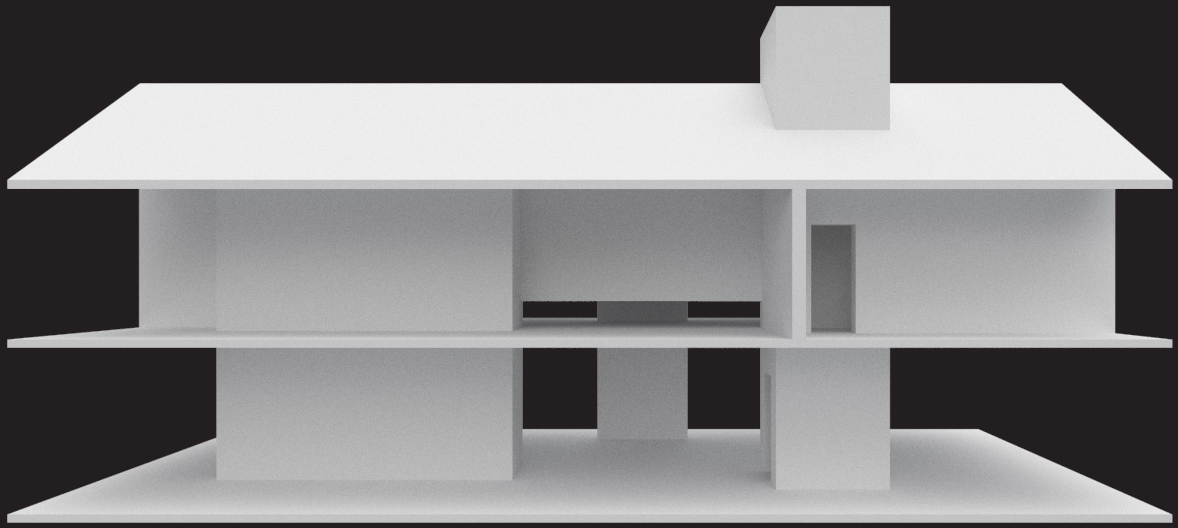

Prister's House with a Hidden Graveyard

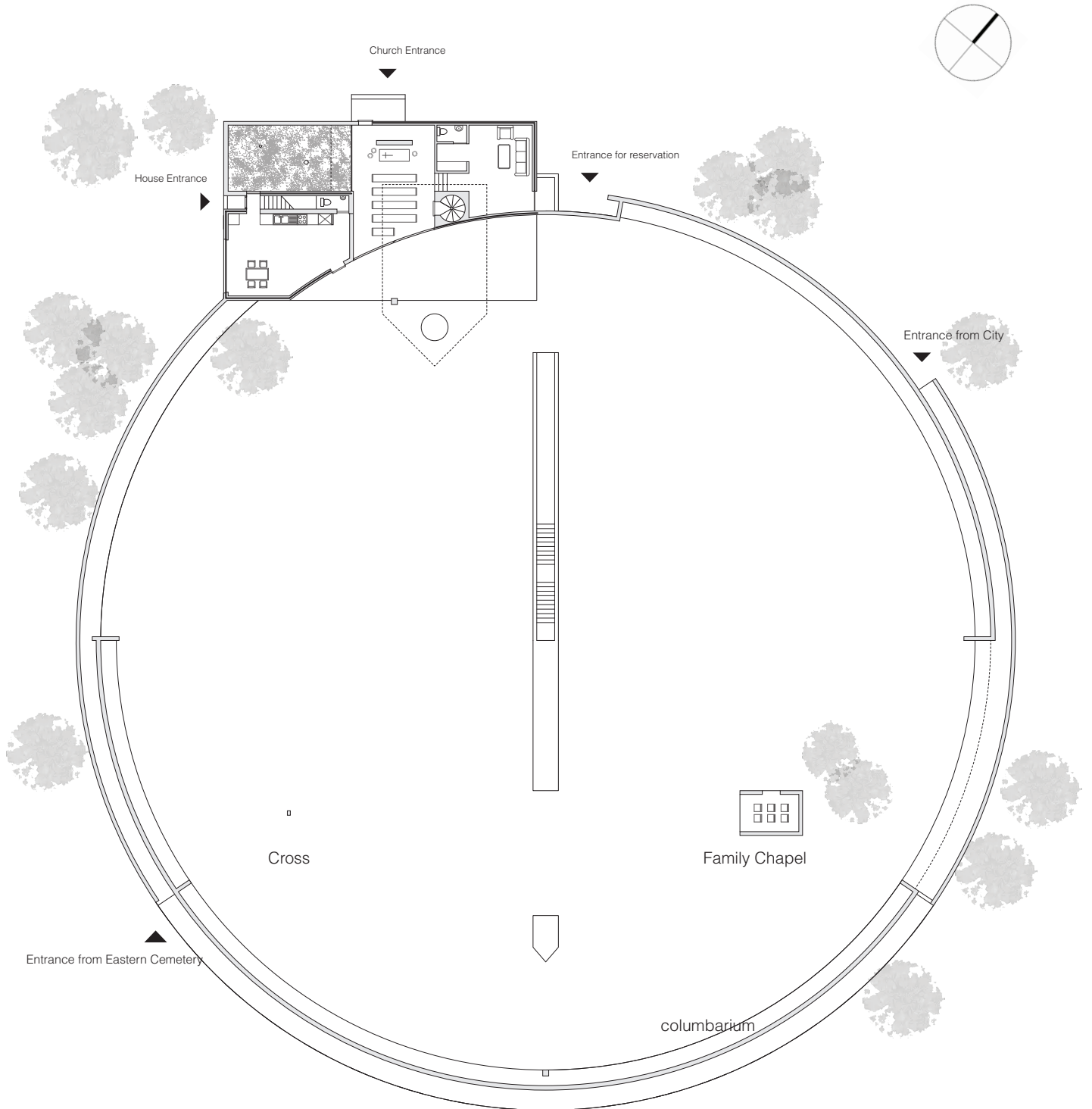

Ground floor



- 1 *Entry*
- 2 *Patio*
- 3 *Prayer room*
- 4 *Lounge*
- 5 *Cloakroom*
- 6 *Kitchen*
- 7 *Platform*
- 8 *Toilet*

Ground floor



- 1 *Living room*
- 2 *Bedroom*
- 3 *Study room*
- 4 *Gallery*
- 5 *Toilet*
- 6 *Patio*

First floor

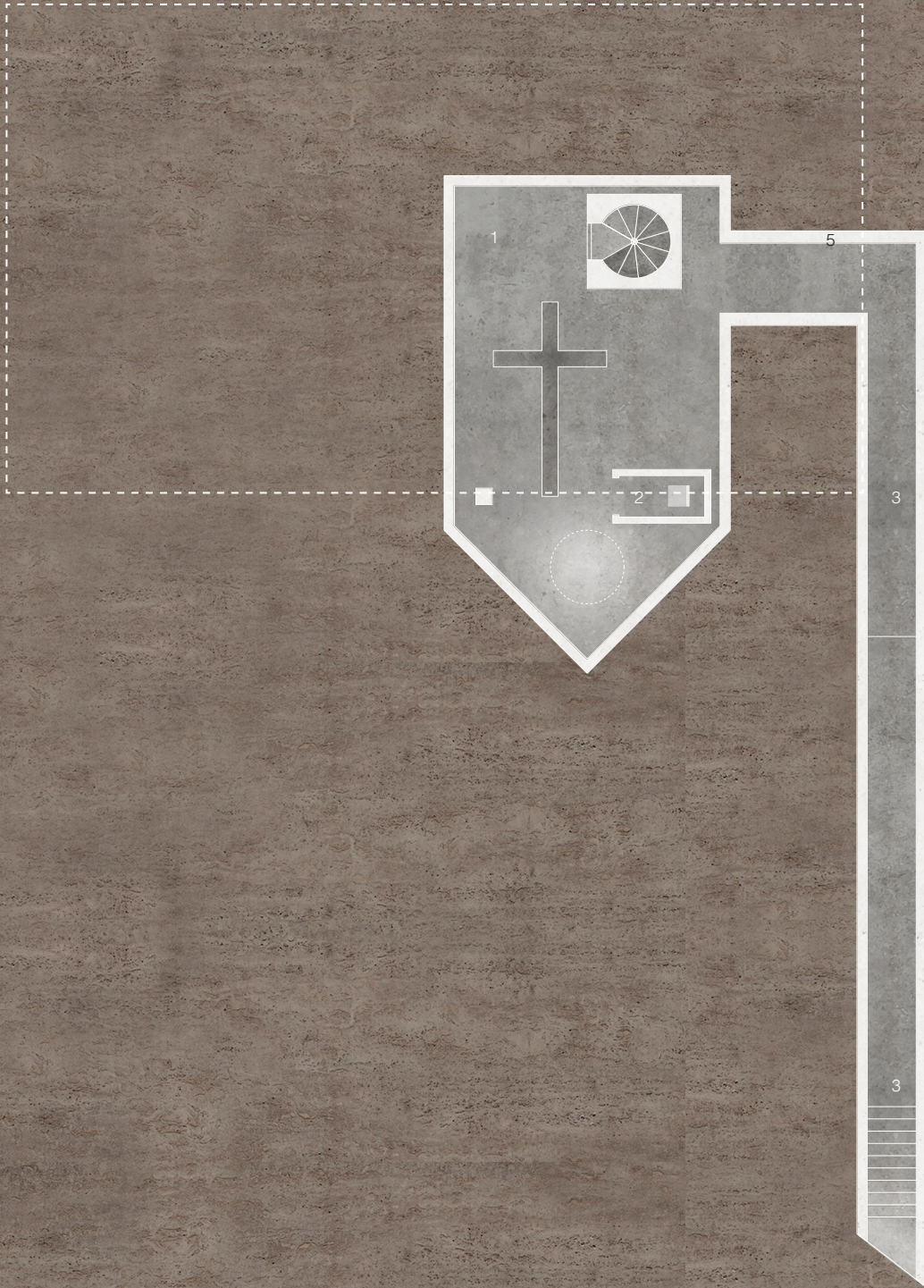

- 1 Farewell court
- 2 Meditation room
- 3 Tunnel
- 4 Steps to Garden

Basement

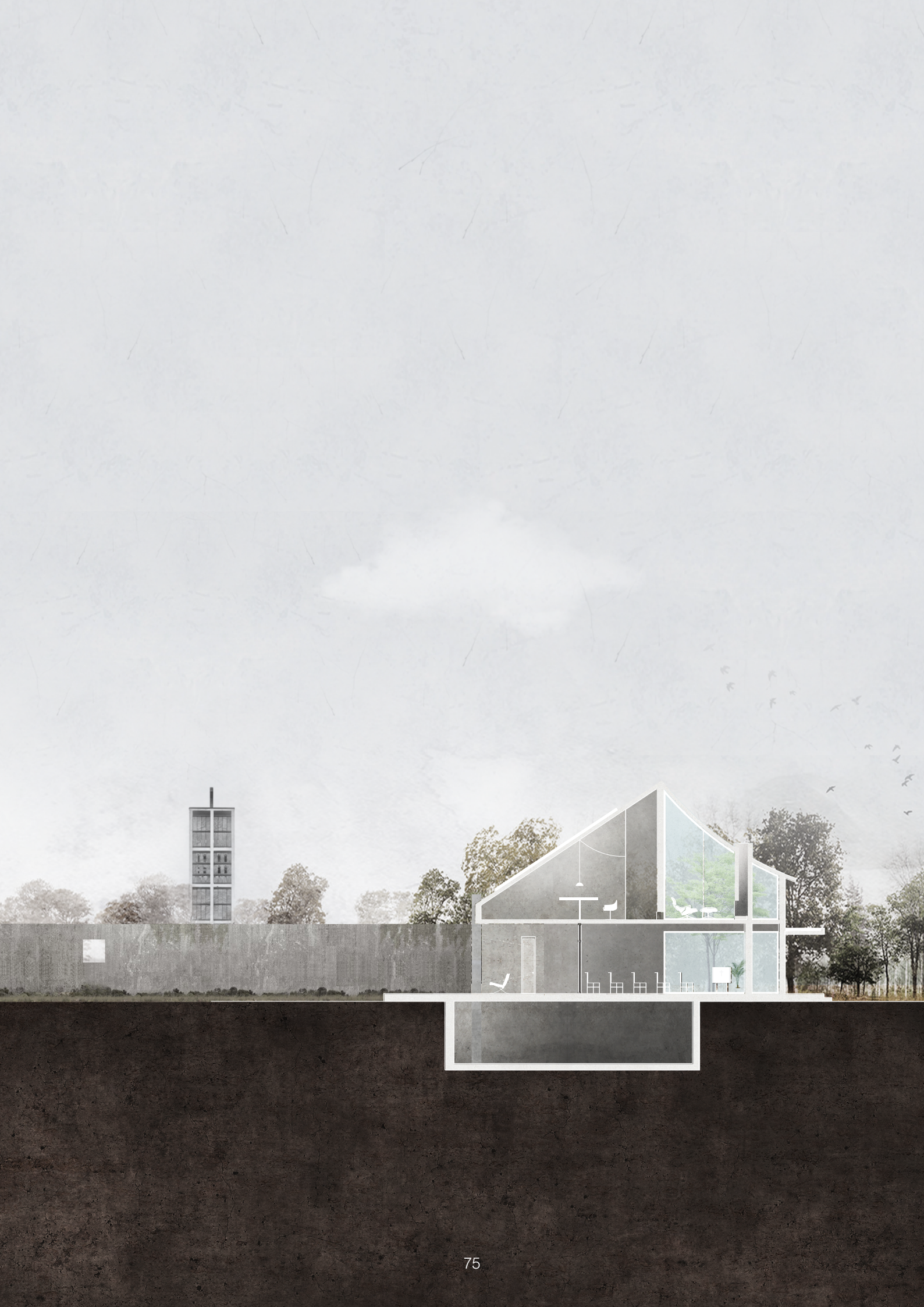



Overview of the Preist's study room (working space)



The warm, natural character of the wood and the curved roof and proportions create a dense and intimate atmosphere.



Transitional platform where cemetery garden meets church



Looking at the patio from the prayer room



The farewell room, where the the priest conducts the religious service and it can be used for private prayers and meditation



In this sense, this house with a hidden cemetery can be seen as a model of the world; it represents an order we cannot directly experience in the world, but at the same time it makes perceptible, within the limits of a building, that which exists in the world.

DISCUSSION

Q&A

- What is the definition of contradiction and complexity ?

The contradiction in space is mainly arisen or triggered by challenging people's previous recognition or experience, and the opposed representation of one architectural component (stair for instance).

The complexity in space are defined in spatial division, skeleton, dimension, creating different spatial experience through the spatial sequence.

- How can users have holistic approach and understanding of space through contradiction and complexity?

Gestalt Psychology's research believes that it's more difficult to perceive the complexity and contradiction, which might evoke a sense of tension, and it is necessary to carry out positive consciousness. But once completed and the tension is gone, people will get more aesthetic satisfaction. Overall, people have to take time to perceive the contradiction and complexity step by step through the spatial sequence and collect all the spatial experience.

- How to use contradiction and complexity as a method force to design a project in a certain context?

First, we need to understand the existing contradiction and complexity in the certain context, and then analyze them respectively and propose if those points could be the starting point or the design guiding principle in architecture that would reflect or respond to the context, being the extension of the context with conditional architectural autonomy.

Summary

Many modern architectures reject contradiction and complexity in space due to the need of efficiency in functions or programs, thus creating a lot of generic space, in which the users are the designer of the space instead of the architects, in this case, users would not have a deeply holistic approach to space, and how to improve the spatial experience due to the simplicity and shallowness.

Therefore, I intend to bring the contradiction and complexity in space into the discourse of architecture and use the method in a design project as an experiment in a certain context. Hopefully, I would bring my methodology of the Master thesis further in my professional practice

REFERENCES

1. Sigurd Lewerentz, architect : 1885-1975 / Janne Ahlin.
2. Architect Sigurd Lewerentz Vol. 1 Photographs of the work / with an essay by Wilfried Wang ; photographs by Fabio Galli ;
3. Architect Sigurd Lewerentz Vol. 2 Drawings / supervised by Janne Ahlin.
4. Equality in death: Sigurd Lewerentz and the planning of Malmo Eastern Cemetery 1916–1973. Campo-Ruiz, Ingrid, 2015
5. Malmö Eastern Cemetery and Lewerentz's critical approach to monumentality, Campo-Ruiz
- 6.1. Sigurd Lewerentz, 'Modern Cemeteries: Notes on the Landscape', 1939, translated and printed in Nicola Flora, Paolo Giardiello and Gennaro Postiglione (eds), Sigurd Lewerentz 1885–1975, trans. D. Stanton (Milan: Electa Architecture, 2002), pp. 44–45.
7. Complexity and Contradiction in Architecture Turns 50. By: JENCKS, CHARLES, Architectural Record, 0003858X, May 2016, Vol. 204, Issue 5
8. Complexity and contradiction in architecture / Robert Venturi. Book By: Venturi, Robert. London : Architectural Press, 1977.
9. Non-referential Architecture Ideated by Valerio Olgiati - Written by Markus Breitschmid / Valerio Olgiati, Markus Breitschmid. 2019
10. Valerio Olgiati / editor: Laurent Stalder. 2010
11. Die Bedeutung der Idee in der Architektur von Valerio Olgiati / The significance of the idea in the architecture of Valerio Olgiati / Markus Breitschmid. 2008