

Homage to home

*An architectural investigation at Stora Stenbrottet
in the Kinnekulle region*

Ulrike Donnerhack

Examiner / Björn Gross | Supervisor / Mikael Ekegren



Building & Tectonics
Department of Architecture & Civil Engineering
Chalmers School of Technology
Spring 2022



CHALMERS
UNIVERSITY OF TECHNOLOGY

*Homage to home / an architectural investigation at Stora
Stenbrottet in the Kinnekulle region*

Ulrike Donnerhack

Spring 2022

Chalmers School of Architecture
Department of Architecture and Civil Engineering
Master's Programme of Architecture and Urban Design
Direction / Building & Tectonics

Examiner / Björn Gross | Supervisor / Mikael Ekegren

*A warm thank you for all your help, insights, information and
inspiration:*

Unnar Kristmannsson
Samhällsbyggnadschef, Götene kommun
Juliane Thorin
Kommunutvecklare, Götene kommun
Måns Nyström
GIS-ingenjör, Götene kommun
Anna Lokrantz
Bebyggelseantikvarie Lokrantz Kulturmiljö
Anna Ohlin Ek
VD Destination Läckö-Kinneulle AB
Gustav Thor
VD Thorsbergs Stenhuggeri AB
Eric Julihn
Råbäcks Mekaniska Stenhuggeri
Sofia Hultman
Platåbergens Geopark
Marie Forsell
Arkivassistent, Västergötlands museum
Mikael Ekegren
Supervisor
Björn Gross
Examiner

Thank you also to:

My mom - for your endless love and support

.

For my dad - I hope you would be proud



Abstract

“Architecture is the very mirror of life. You only have to cast your eyes on buildings to feel the presence of the past, the spirit of a place; they are the reflection of society.”

- I. M. Pei

In this thesis, I return to my home region on Kinnekulle in order to explore how the design of a public building can connect to and enhance the experience of a place and the cultural history of a region.

Through a research by design approach the thesis aims to investigate traditional stone- and timber building techniques from the area of Kinnekulle and explore how they could be translated into the typology of a modern visitors center and through this contribute to the knowledge on using stone and timber as a building material in an architectural project.

The thesis engages with theory on architectural regionalism, tectonics and materiality and through studies on site, in models, sketches and drawings results in a two-part visitor center at the large quarry on Kinnekulle. One part tells the narrative of stone — its durability, strength and timelessness. The other part tells the tale of wood — its lightness and warmth. Through this the thesis aims to pay homage to two contrasting materials — to a place — and to the cultural heritage of Kinnekulle.

Contents

Abstract

Contents

Student Background

Education

Experience

1. Introduction	9
1.1 Thesis questions	10
1.2 Purpose & aim	11
1.3 Research typology	12
1.4 Methods	13
1.5 Delimitations	16
2. Discourse	19
2.1 Theoretical references	20
2.2 Architectural references	26
3. Investigation	31
3.1 Studies on context and tradition	32
3.2 Studies on context and site	40
4. Design proposal	45
4.1 Concept	46
4.2 Situation	48
4.3 Building	54
4.4 Detail	66
5. Discussion	75
5.1 Conclusion	76
5.2 Reflection	77
6. Bibliography	78
6.1 Literature	80
6.2 Figures	83

Student background



Education

- 20 - present* M.Sc in Architecture and Urban Design
Chalmers University of Technology
- Studios /
Sust. Dev. & the Design Professions
Material & Detail
Architectural Competitions
History, Theory & Method 4
Matter, Space, Structure 2
Matter, Space, Structure 3
Master's Thesis prep. course pt.1
Master's Thesis prep. course pt.2*
- 16-19* B.Sc in Architecture
Lund University of Technology
- 13-16* B.Sc in Urban & Regional Planning
Lund University
- autumn 15* Exchange semester - Human Geography
Queen's University Belfast

Experience

- 21 - 22* Norrgavel
/ Interior & furniture sales
Gothenburg
- 19-20* Liljewall Arkitekter
/ Internship
Gothenburg
- summer 17* Stadsbyggnadskontoret
summer 18 / Internship
Malmö
- 16-18* Lundagård Student Paper
/ Photographer
Lund

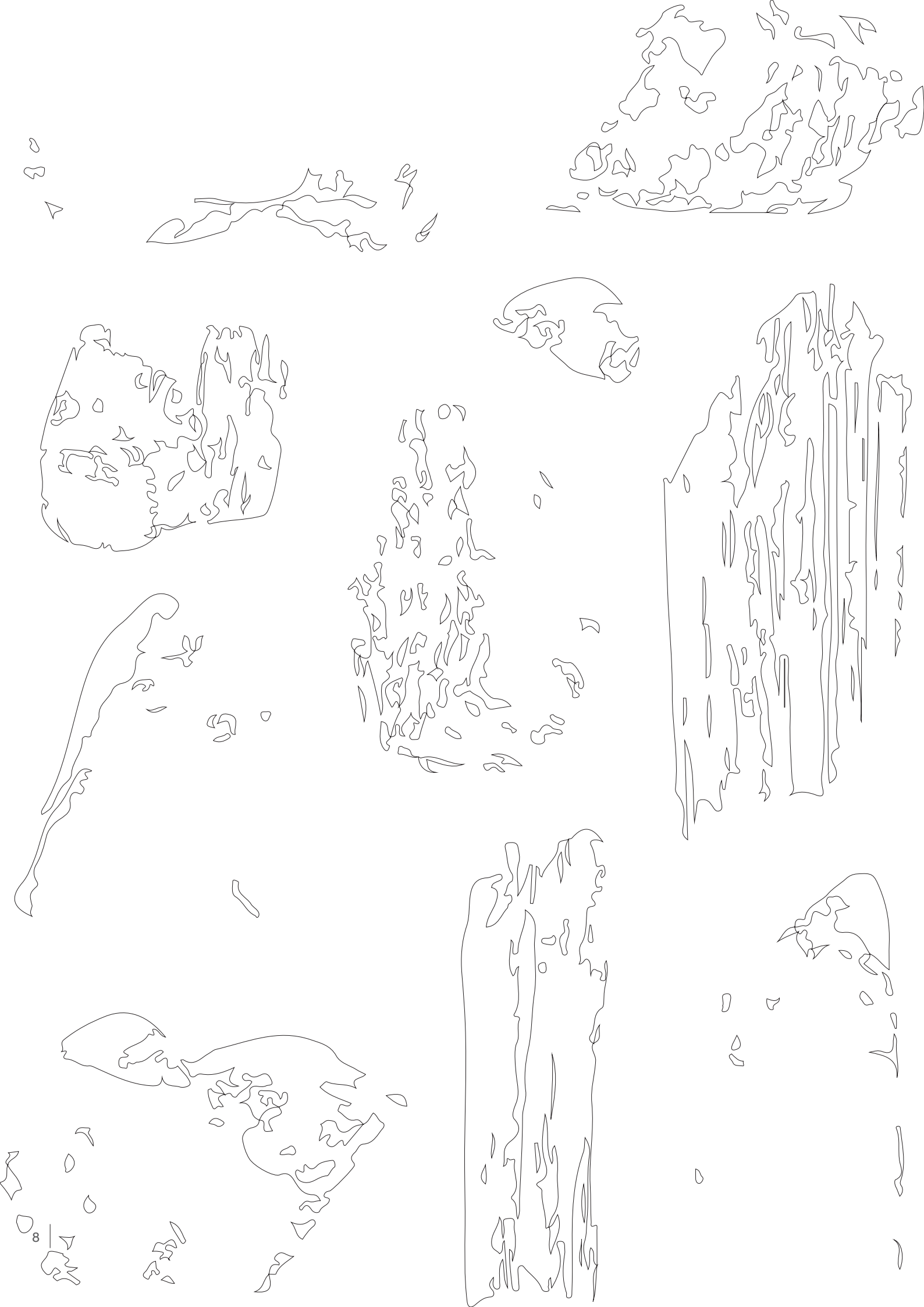

1. Introduction

1.1 Thesis questions

1.2 Purpose & aim

1.3 Research typology

1.4 Methods

1.5 Delimitations

1.1 Thesis question

This thesis aims to explore the following research question:

- How can the design of a public building connect to - and enhance the experience of a place and the cultural history of a region?

Sub-question:

- What traditional building techniques and typologies exist on Kinnekulle and how could they be adapted to modern building standards?

1.2 Purpose & aim

The purpose of this master's thesis is to investigate how material and construction give atmosphere to space and to explore how the contemporary design of a public building can connect to a longstanding local building tradition.

The thesis aims to investigate traditional stone- and timber building techniques from the area of Kinnekulle and explore how they could be translated into the typology of a modern visitors center and through this contribute to the knowledge on using stone and timber as a building material in an architectural project.

The purpose is further to develop a draft or idea sketch of a public visitor center for Götene kommun which can serve as an inspiration for the municipality and kick-start discussions on possible developments in the area.

Furthermore the thesis aims to highlight existing qualities of the Kinnekulle region relating to nature, culture and history with particular focus on the history of the stone industry and its related cultural heritage.

1.3 Research typology

The research typologies used in this thesis fall into the two categories of 1. *Research on design* and 2. *Research by design*. The main typology employed in the thesis is *Research by design* which is defined by Hauberg (2011) as follows:

“Research by design is research through design. [...] In research by design, the architectural design process forms a pathway through which new insights, knowledge, practices and products come into being. Research by design generates critical inquiry through design work that may include realized projects, proposals, possible realities and alternatives. [...] Research by design is research that produces knowledge through the architect’s tools and working methods. It investigates the research inquiry from the practitioner’s methods and acknowledges practice as a means of gaining new knowledge.”
(Hauberg, 2011, p. 51-52)

1. *Research on design in this thesis encompasses:*

- studying relevant references and architectural predecessors
- studying relevant literature
- studying the site and its surrounding context(s)
- studying traditional stone and timber buildings in the area of Kinnekulle

2. *Research by design in this thesis encompasses:*

- modelmaking
- sketching
- producing and exploring drawings at various scales and details
- creating perspectives and other artistic methods

1.4 Methods

This chapter gives an overview of the various methods I have used to both investigate the research questions and implement my findings in a design proposal. The main methods consist of literature- and reference studies, site analysis using mapping and photogrammetry as well as elaborations through sketches, models, drawings and digital imagery.

1.4.1 Literature- and reference studies

This thesis does not claim to do an exhaustive or systematic literature study but rather a general overview of relevant literature will be studied in relation to the thesis question(s).

The literature has been chosen in relation to its relevance for answering the thesis question and consists of:

- theoretical texts on the interplay between architecture , tectonics and materials and their related spatial qualities
- theoretical texts on architectural regionalism
- theoretical texts on sustainable building materials

Reference projects within the field of architecture and construction have also been chosen in relation to their relevance for the thesis question.

1.4.2 Site analysis

In *Arkitektens handbok* Bodin et. al (2016) make note of the importance of making an inventory of the landscape or site where the project will be located in order to be able to adapt to- and take the specific context into consideration in the design.

Mapping/Inventory

As a ***first step*** of the site analysis Bodin et. al (2016) suggest gathering all available maps and documents about the site, for instance development plans, basic maps, topography maps, historic maps, orthophotography as well as previous inventories and studying these thoroughly.

The **second step** should be going to the site and making your own inventory of:

- Spatial and visual qualities
- Building structure
- Nature and plants
- Technical and environmental aspects
- Connections, accessibility, traffic
- Social aspects
- Private / Public
- Changes
- History, continuity
- Legal boundaries
- The unexpected

The **third step** is to document the inventory through photographs, sketches, notes, site models, digital models and drawings.

This thesis has loosely followed the process as suggested by Bordin et al. (2016) and the site investigation is presented further in chapter 3.

Photogrammetry

Photogrammetry is “[...] measurement in photographic images of size, shape and position of photographed objects”. (Nationalkylopedin, n.d.) [author’s own translation]

As part of the site analysis images captured by a remote controlled drone were put into a photogrammetry software in order to create a 3D digital model of the site.

1.4.3 Elaborations/iterations through sketches, models, drawings and digital imagery

Below are two longer quotes that I believe summarize the benefits of working with sketching and modeling as a way of developing the architectural design. The quotes also highlight how I view sketching and modeling in my own design process:

”Sketching can serve many purposes: communication, note taking, problem solving, diagrams, as preparation for a larger work, a study of specific parts, as is the case in figure drawing, or it can simply be an act of quick journaling of ideas. It can almost be called the kitchen of thoughts and ideas. Lines and shapes are in constant flux, creating and morphing to fulfill their creator’s intentions and goals. [...] Sketching as design thinking is simply the willingness to work out ideas and concepts with our hands.” (Hoffmann, 2020, p. 16)

”[...] models are in fact first and foremost a means for investigation, for carrying an idea forward. As such, physical models are a uniquely revealing and compelling tool. More forcefully than any other way of visualizing a building— apart from its actual construction— models represent ideas, as opposed to images. Embedded in the model is the concept of the design, which the model translates into matter and time. And each of these worlds— the material and the temporal— imposes itself on the designer’s investigation. Physical models make the invisible visible: the rules that apply to matter and time become evident to the model maker and thus become filters for his or her design explorations.” (Werner, 2011, p. 12)

Tools used within this method consists of pen and paper, iPad and apple pencil, software for digital 3D modeling such as ArchiCAD and Rhinoceros 7, digital CNC-milling machine, tools and materials for modelmaking and programs from the Adobe Suite.

1.5 Delimitations

No consideration has been given to the shoreline protection regulations [strandskydd] in this project and the same goes for connections to the municipal water- and wastewater network. However it can be noted that there are plans to extend the water- and wastewater networks on Kinnekulle and also preliminary ideas about the placement of a visitor center on the spot of the project site but the exact logistics of this fall outside the scope of this thesis.

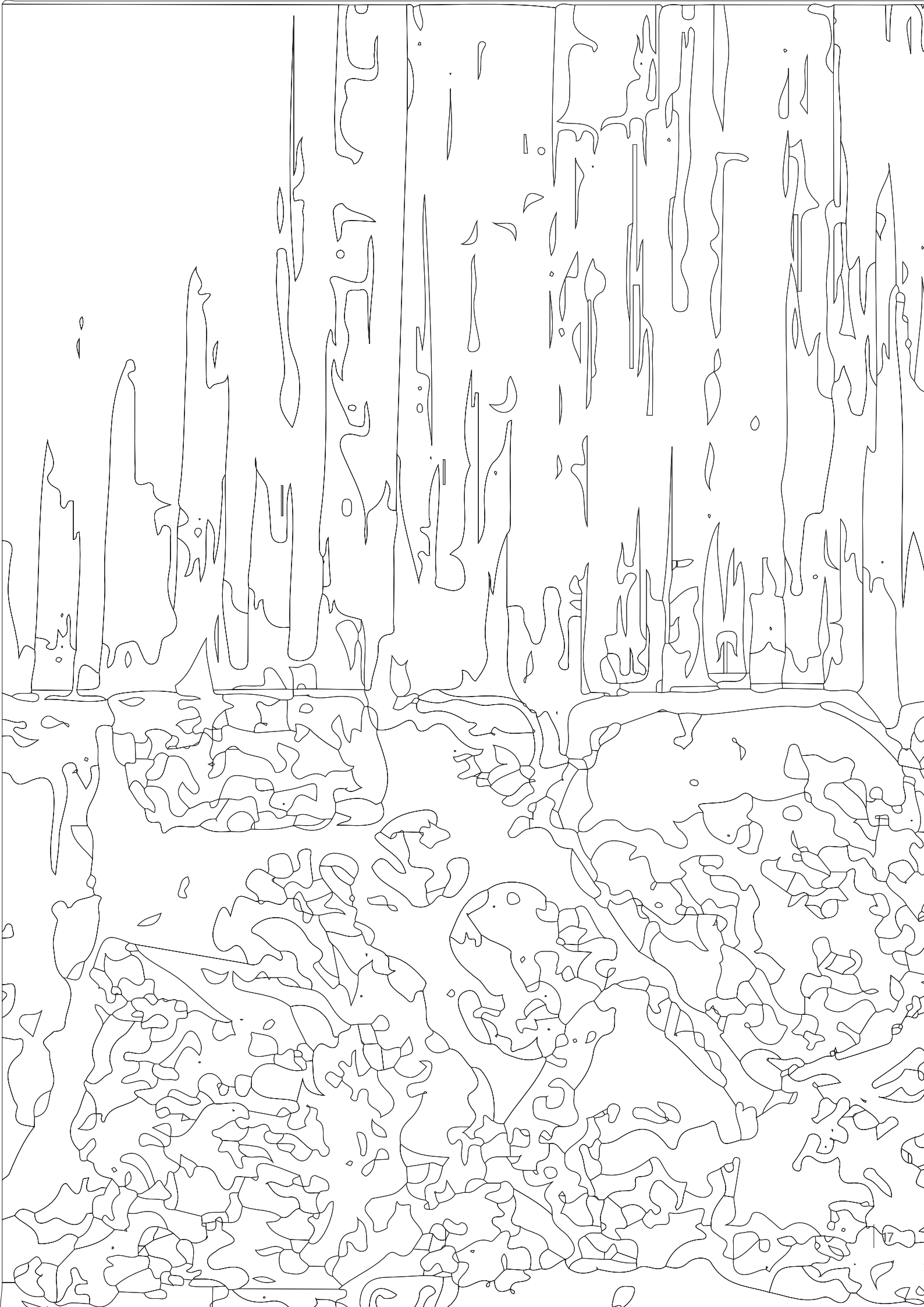



2. Discourse

2.1 Theoretical references

2.2 Architectural references

2.1 Theoretical references

2.1.1 Architectural regionalism

In his book *Basic Design Methods* Jormakka (2013) states that a lot of what is architectural design is based on the architect's own creative thoughts, processes and background while some of the design might be based on different methodological principles or approaches. These approaches in turn reflect certain attitudes and processes. One such approach on how to develop an architectural design is called regionalism, which Jormakka defines as follows: “*In regionalism, the architect tries to adopt some features not necessarily from the immediate environment but from the region or the nation.*” (Jormakka, 2013, p.60)

In architectural regionalism the architects pay special attention to the project's local context with regards to local materials and building techniques as a way to make use of prior knowledge of what is functioning and suitable for that particular area. This can contribute to keeping the cost of the project down and also serve as an economic stimulant for the community if, for instance, local builders are employed in the project (Jormakka, 2013).

In his book *Architectural Regionalism: Collected Writings on Place, Identity, Modernity, and Tradition* Canizaro (2007) writes:

“Regionalism is the preeminent discourse in architecture that focuses on design in terms of particularity and locale. It suggests that local experiences, the kind most of us have most of the time, should serve as the basis for architectural design. This does not preclude the myriad and powerful issues any field allied with art may entertain, including experimentation, expressiveness, and the necessity of challenging ourselves to think; it simply re-prioritizes those concerns so that local quality of life is always at the forefront.” (Canizaro, 2007, p. 12)

This means that regionalism doesn't negate progress but rather suggests that new architectural projects have a stronger connection to the shared history and memory of its location (Canizaro, 2007). It is also important to note that architectural regionalism is hard to define as one singular approach but rather its theoretical background displays multiple perceptions and varying standpoints.

However, the common standpoint of architectural regionalism is that it opposes “[...] *various forms of hegemonic, universal, or otherwise standardizing structures that would diminish local differentiation.*” (Canizario, 2007, p. 20)

2.1.2 Critical regionalism

As a way to deal with the critique against regionalism for being over-focused on local history, *critical regionalism* emerged as a theoretical direction within architectural regionalism. One of its pioneers, Kenneth Frampton, argued that one could be vary of sentimentalism whilst still taking local experiences into account (Canizario, 2006). Jormakka (2013) writes the following about Framptons view on critical regionalism:

“[...] critical regionalism focuses on local specificities in order to resist the uniformity of capitalist modernity. It deconstructs the overall spectrum of world culture it has inherited and critiques universal civilization. On a more concrete level, Frampton advises architects to use local materials in a tectonic way, i.e. revealing the actual construction, instead of the abstract and generic constructions typical of international modernism.” (Jormakka, 2013, p. 61)

Swiss architect Gion A. Caminada is one of today's architects who has made a large contribution to the field of architectural regionalism in both theory and practice. Caminada has spent most of his life working on projects in the rural village of Vrin contributing to its development but also to its preservation. Caminadas work is defined by “[...] *a close connection between social context, economic conditions, anthropological constant and historical context.*” (Caminada & Aicher, 2018, p. 10) Caminada has a quite pragmatic view on the architectural design process where he doesn't completely reject global influences and new technologies in his work but at the same time insists that the material used in the construction has something to do with the place and the local craftsmanship (Caminada & Aicher, 2018, p. 145-146).

2.1.3 Building, tectonics & materiality

Tectonics

"Tectonic theory is integrative; it examines "the interwoven relationship between space, function, structure, context, symbolism, representation, and construction. No single definition exists that conveys the full meaning of the term tectonic, primarily because it has evolved over time." (Schwartz, 2017, p. 33)

One could perhaps say that tectonic theory emerged in contrast to various styles such as neoclassicism during the 1800's where ornament and the finished 'surface' of the building was thought of as being more important than the buildings structural- and load bearing system. Tectonic theory thus "[...] sought exterior expression for the underlying structural systems and mechanics that allow for the creation of built space." (Schwartz, 2017, p. 33)

It thus follows that the experience of architectural space not only depends on 'finished' surfaces and their visual impression but rather on how the design is realized technically- and structurally as well as on the building materials used.

Relating to how the design is realized structurally, Deplazes (2018) divides architectural form in two primary categories **(1) solid construction** and **(2) filigree construction**. The type of construction we choose relates directly to what becomes possible to do with the design and also how we will end up perceiving the space that is created.

Solid construction is related to earthwork meaning for instance compact wall constructions such as clay- and stone masonry. It is characterized by heaviness and solidity. Solid construction creates enclosed spaces with a clear differentiation between what is inside and what is outside. The openings are usually kept as small as possible so as to not damage the structural integrity and load-bearing capacity of the walls (Deplazes, 2018).

Filigree construction on the other hand is related to structures with slender members such as beams and columns. In contrast to solid construction, filigree construction can take care of both tensile and compressive forces. Furthermore filigree construction needs additional enclosing elements in order to create an interior space and it can also handle much larger openings. Filigree construction is characterized by being light-weight and open (Deplazes, 2018).

Materiality

In his lecture on Atmospheres (2008) Peter Zumthor states that *"Materials react with one another and have their radiance, so that the material composition gives rise to something unique."* (p. 25) He further states that *"There's a critical proximity between materials, depending on the type of material and its weight. You can combine different materials in a building and there's a certain point where you'll find they're too far away from each other to react and there's a point too where they're too close together and that kills them."* (Zumthor, 2006, p.27)

Gustavsson (2008) defines materiality as how we humans interpret a material with our mind and our intellect. He further suggests that it is the characteristics of the material itself that are decisive for our interpretation of it as well as our subjective references and experiences. For instance we can experience a material as warm or cold, hard or soft, heavy or light. A materials load bearing capacity as well as other constructive parameters also contribute to the perceived materiality of the material. Gustavsson (2008) further argues for the importance of making buildings 'readable' which means using the materials in a way that coincides with their characteristics, to be clear about the transition between materials as well as in their joinery.

2.1.4 Sustainable building materials

In the book *Sustainability of Construction Materials* Khatib et. al. (2016) state that the construction industry accounts for large amounts of the consumption of raw materials, many of which are nonrenewable or whose extraction, processing and transportation contribute to increased greenhouse gas emissions and pollution which are responsible for our current climate crisis. It is thus of vital importance that the construction industry finds new, more sustainable ways of building and utilizing natural resources. Predominantly, the choice of construction materials is based on cost, availability and aesthetics. However, as Khatib et. al. (2016) state, it is now increasingly important to also look at several other indicators with regards to sustainability such as (1) *resource efficiency*: using materials that can be recycled or materials that have a high durability, (2) *energy and carbon*: use materials with low levels of embodied energy as well as materials that are minimally processed and that rely on extraction or manufacture techniques with low energy use and (3) *support social and general well-being*: use materials that contribute to social or economic well being (Khatib et. al, 2016).

In this thesis two materials are explored in the architectural design of a visitors center. The materials are *wood and natural stone*. Stone typically falls into the category of solid construction and wood typically in the category of filigree construction and both materials are found in traditional buildings in the Kinnekulle area.

Natural stone

Natural stone has historically been a dominant building material, spanning over various epochs as well as differing cultures. The inherent properties of stone make it resistant to fire, pressure, weather, wind, rot and other mechanical stresses whilst still being workable by both hand and machine and it also has fairly good availability as a source for building material (Borgström, 1957, p. 5-6). Borgström further argues that natural stone has several of the qualities that we tend to value highly in the architectural design of a building, namely durability, strength and an aesthetically pleasing patina. On the other hand, so Borgström, natural stone is also defined as being heavy and as having a high thermal conductivity which makes it less appropriate for

construction. Thus, we nowadays only tend to see natural stone used as thin slates in facade coverings or used as floors and wall tiles rather than as a structural material (Borgström, 1957).

Schulz & Schulz et. al. (2020) have written the exhaustive book *Manual of Natural Stone - Modern usage of a classic building material*. The authors also argue for the sustainability of natural stone as a building material as well as for it being an economically sound investment seen from a life-cycle perspective as stone has long durability and requires little- to no maintenance (Schulz & Schulz et. al., 2020)

Wood

Wood is an important sustainable material because it is entirely renewable, biodegradable, recyclable and also because it binds the greenhouse gas carbon dioxide in its structure (Khatib et. al., 2016) Khatib et. al. state that: "*Wood from sustainably managed forests is arguably one of the most environmentally friendly construction materials available.*" (Khatib et. al., 2016, p. 130)

Timber, which is the processed form of wood used for building, is: "[...] lightweight and strong in bending, compression and tension, [and] it is capable of performing all the basic structural functions." (Khatib et. al., 2016, p. 134) Wood has fairly low thermal conductivity, especially in comparison with steel or concrete which makes it an efficient material when it comes to avoiding heat losses through the building envelope (Deplazes, 2018).

Wood is also a regional material where a certain region could be known for using a specific type of tree in the construction of a building. Other characteristics of wood relate more to its materiality where wood has been described as creating an atmosphere of warmth and comfort. Further it is a material that visibly ages - we can read the passage of time in its structure and it stimulates more of our senses such as smell where each species of tree has its own unique smell (Glasner & Ott, 2012).

2.3 Architectural references



Fig. 1. Alpine Chapel Wirmboden / Innauer-Matt Architects (Bereuter, 2017)

Alpine Chapel, Wirmboden | Innauer-Matt Architects 2017

About the reference:

The chapel is situated in a pasture in Austria which is collectively owned by farmers from the village. The previously existing chapel was destroyed in an avalanche and it was challenging to rebuild the little chapel because of differing opinions within the farmers collective (ArchDaily, 2017). The chapel is the result of a collective effort where the community was involved in both planning and building and it has now become a small center of community life. The walls are made of concrete mixed with locally collected stones as is tradition. The solid walls and foundation is complemented by a lightweight wooden roof construction covered in wooden shingles (ibid).

What I've taken with me from the reference:

It is important to think about the large impact a new addition has in a small community - the countryside is not like the city and great care needs to be taken in adding onto the existing tradition of a place. Architecture-wise the heavy walls carry the light roof which makes for a beautiful contrast material-wise and an easy-to-read construction.



Fig. 2. Kroklada Öland / Lowen Widman Arkitekter (Lowen Widman Arkitekter, 2013)

Kroklada Öland | Lowen Widman Arkitekter
2013

About the reference:

The design is inspired by a regional building typology called "kroklada". The typology is strongly linked to regional identity and local history and the building thus aims to be a natural addition in the landscape (Lowen Widman Arkitekter, n.d.) The construction is made in modified "skiftesverk" (post-and-plank) which is a traditional timber frame with horizontal plank or log infill.

What I've taken with me from the reference:

I've mainly been really inspired by the process of designing a contemporary building that strongly connects to the local history and characteristics but also adapting it to fit with modern building standards. I've also had a close look at the construction drawings for this project in order to find inspiration for my design.



Fig. 3. Arkitekturfoto av Villa Schreiner (Teigens Fotoatelier, 1963-1965)

Villa Schreiner | Sverre Fehn
1959-1963

About the reference:

Villa Schreiner is built up of a post-beam structure on a 1-meter grid. The villa stands on a plinth foundation and has wooden terraces that go around almost the whole house. The facade is clad with horizontal planks and sliding doors are used for maximal usage of space (Atlas of Places, 2020).

What I've taken with me from the reference:

I think my final design has been strongly influenced by this reference especially when it comes to the horizontal emphasis of the facade and ribbon windows as well as the whole post-beam construction system.



Fig. 4. Boge Friggars House (Sundström, 2019)

Boge Friggars House | Scott Rasmusson Källander
2019

About the reference:

The project consists of 5 summer houses in a small area on Gotland in Sweden. The houses are divided in two parts with one more open and public part and one more intimate and closed-off part that are connected through the roof. The structure is a post-beam construction in exposed wood and standing on plinths elevating the whole project from the ground (ArchDaily, 2021).

What I've taken with me from the reference:

Similarly to Villa Schreiner this project has been a strong influence on my final design in relation to construction and overall aesthetics. I especially liked the idea of two volumes that are separate in function and also in the expression of being introvert - and extrovert but still connected through the roof.



3. Investigation

3.1 Studies on context and tradition

3.2 Studies on context and site

3.1 Studies on context and tradition

3.1.1 About the Kinnekulle region

Kinnekulle is a mountain on the southeastern shore of Lake Vänern, in Götene municipality in Västra Götaland. It is a table mountain, meaning a mountain with a flat top, of about 306 meters above sea level. The mountain has a unique geological structure with a complete layer sequence of different rocks consisting of basement rock, sandstone, alum shale, limestone, clay shale and dolerite (Platåbergens Geopark, 2018). Due to its diversity of rock types Kinnekulle also has a unique variation in habitat types such as deciduous forest, spruce- and fir forests, meadows and pastures (Västsverige, n.d.).

Large parts of Kinnekulle have become nature reserves and are part of the EU network of protected areas, *Natura 2000*. Kinnekulle is also part of UNESCO Biosphere reserves called *Biosfär-område Vänerskärgården med Kinnekulle* and UNESCO Global Geopark called *Platåbergens Geopark*. Being part of these networks signals that Kinnekulle is an internationally significant area with regards to geology, nature and cultural history (Länsstyrelsen Västra Götaland, n.d.).

Due to the rich variety of nature and fertile soil Kinnekulle has been inhabited for millennia and the people in the area have traditionally used and worked with stone since the first settlements, something that old cemeteries, rock carvings and cairns show (Västsverige, n.d.). Kinnekulle is a popular tourist destination and recreational area. The hiking trail called "Kinnekulleleden" is a 45 km long trail that runs around the mountain and there are several landmarks such as small waterfalls and medieval churches in the area (ibid).

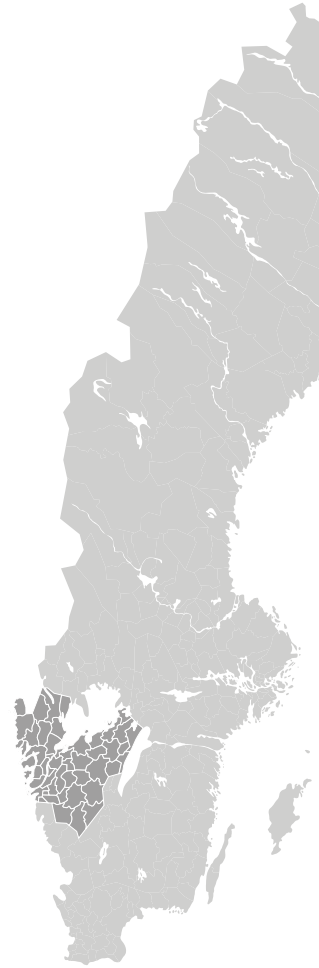





3.1.2 Stone building tradition

At Kinnekulle, stone from the mountain has been used for various purposes since the Middle Ages. Early on, hewn stone and burnt lime were extracted and used in the building of houses, churches, graves and other structures. Kinnekulle thus became an important center for the stone industry and the craft of stone masons. Between 1894 to 1946 slate oil was occasionally extracted from alum shale in various places and there was also a cement factory in Hällekis between 1892 and 1978 which used the large quarry "*Stora Stenbrottet*" that is now a recreational area (Platåbergens Geopark, 2018).

Traditional walls made out of natural stone are made as dry stone walls [swe: kallmur] which means that they are made out of stacked stones without any mortar to bind them together. The stones that were used for the wall were usually found in direct vicinity to where the wall was being built. Walls made out of limestone were usually cleft to thin slates which were then stacked — openings could be bridged by for instance larger slabs (Sveriges stenindustriförbund, 2005).

The next step for building with stone walls was to set the stones with mortar [swe: bruksmur]. The wall was a massive load bearing double stone wall construction which was often constructed as an outer and an inner wall with an intermediate loose filling of mortar and smaller rocks (Sveriges stenindustriförbund, 2005). A further development of this wall is the cavity wall (more related to brick constructions though) where there is usually one load bearing interior wall and one non-load bearing exterior wall (in some cases the reverse is true or both walls are load bearing) between them is a hollow space which is then filled with insulating material and an air cavity (Gustavsson, 2012).

The third development is the so-called veneer wall [swe: beklädnadsmur] which isn't part of the load bearing structure. The veneer is anchored to the back load-bearing wall through masonry anchors in stainless steel (Sveriges stenindustriförbund, 2005). The space between the veneer and the load bearing wall can either be filled with mortar, left open as an air cavity or filled with insulation. The veneer wall must be at least 90 mm thick, if it is thinner it is considered a wall cladding (Schulz & Schulz, 2020).

During my studies I found that most stone houses on Kinnekulle are made of sand- or limestone, or a combination of both and limestone is the primary stone type still being quarried today. Particularly outbuildings and barns with visible limestone are characteristic of the area. The limestone is mostly laid in random uncoursed or coursed rubble masonry connected with, for the region typical, limestone mortar called "*Kinnekullekalk*". Most of the buildings date back to the mid 1800's but some of them have roots as old as from the 1600's. The walls are typically 70-80 cm thick and uninsulated. The characteristic gable roof is supported by some kind of timber beam structure or timber truss with an outer roof of either wooden shingles of one or two cup tiles. The top part of the gable facade is typically made of vertical wooden laths. Some buildings have a thicker stone base and an accentuation of the corners in pattern-laid red limestone. Openings consist of large hinged wooden double doors and relatively few and small or no windows.

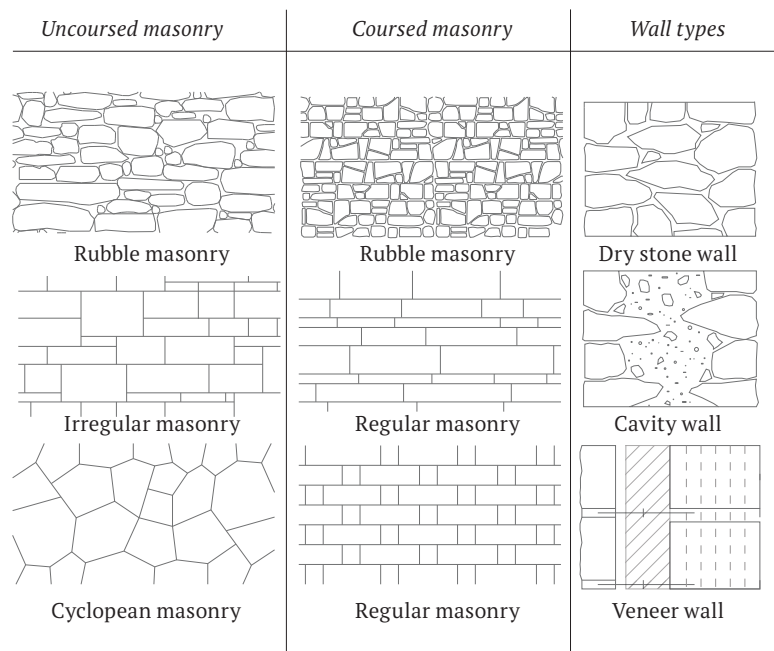



Outhouse in limestone in Västerplana, Kinnekulle



Fig. 5. Lada Skiftesverk (Västergötlands museum, n.d.)

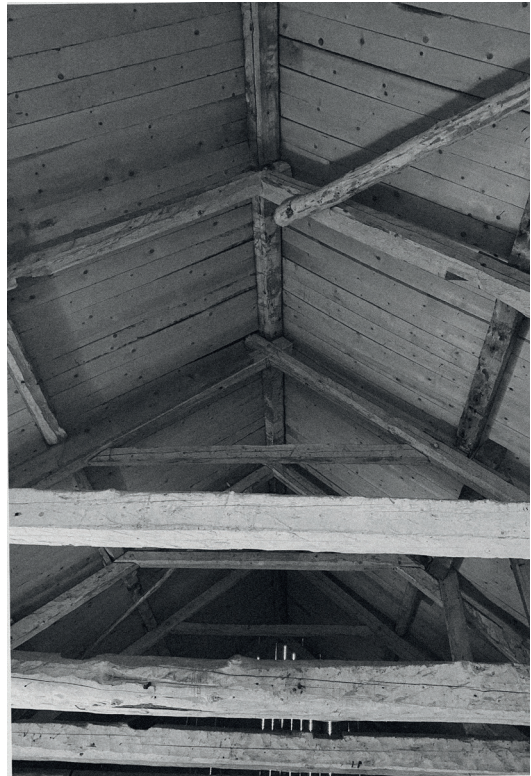

3.1.3 Timber building tradition

In Sweden there has traditionally been three ways to build with timber: post-and-plank [swe: skiftesverk], log timber[knuttrimring] and timber framing [korsvirke]. The three types exist in their pure shape and form but there are also examples where they have influenced each other and been combined in different ways (Henriksson, 2008). Which type was used depended on the accessibility to- and type of wood available. In Västra götaland post-and-plank was the dominant way to build with timber due to good access to deciduous forest and especially oak trees even though the technique was later developed to also work with wood from fir and spruce trees (ibid).

It was often the simpler buildings such as outhouses that were constructed with the post-and-plank technique. The construction is based on planks that are recessed into posts with grooves. Since the distance between the posts can be varied this technique is suitable in areas where there aren't that many tall trees because it is possible to use relatively short planks (Henriksson, 2008).

There aren't many original post-and-plank buildings left in the whole of Sweden however there are some outbuildings still to be found in the vicinity of Kinnekulle for instance in Fornbyn in Skara where they are part of an open air museum.

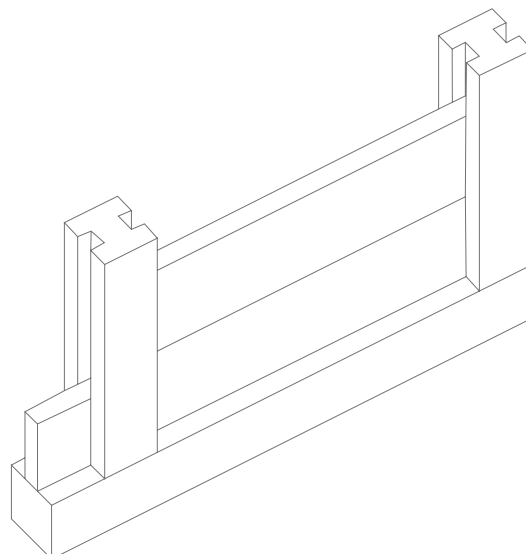

Diagram of post-and-plank construction

3.2 Studies on context and site

3.2.1 About the site

The proposed site for the project is at the large quarry on Kinnekulle called "*Stora Stenbrottet*". The site is one of the area's most visited attractions and has the local nickname 'little Grand Canyon'. In addition to the fantastic views and the environment, in the middle of the quarry there is also a small fishing lake where you can fish rainbow trout (Västsverige, n.d.).

In the quarry you can see 40 meters of Kinnekulles layer of limestone, the so-called orthocar limestone. The stone is clearly divided into layers of both gray and red-brown limestone. During the years 1892-1979 the quarry was used for cement production but today it is a recreational area and a popular destination for excursions (ibid).

The quarry has a central location on Kinnekulle with good connections for visitors on foot or on bike with several hiking trails crossing the area. There are also two large parking lots for visitors who come by car and finally the train stop at the nearby village Råbäck is only about a 20 minute walk away.

3.2.2 Proposed placement

The proposed placement is on the grassy hill that protrudes into the fishing lake making the main accesspoint the roads from the south and south-west. With this placement the main part of the quarry is left intact but at the same time the visitors center is facing the large panorama of the whole quarry and beyond that the view towards the lake Vänern and the horizon.

*1. Main access point
+ southern parking lot*

3. Northern parking lot

2. Proposed project placement

4. Road to Råbäck trainstation

3.2.3 Views from the site



3.2.4 Impressions

"Layers of time forever frozen in the solid rock"

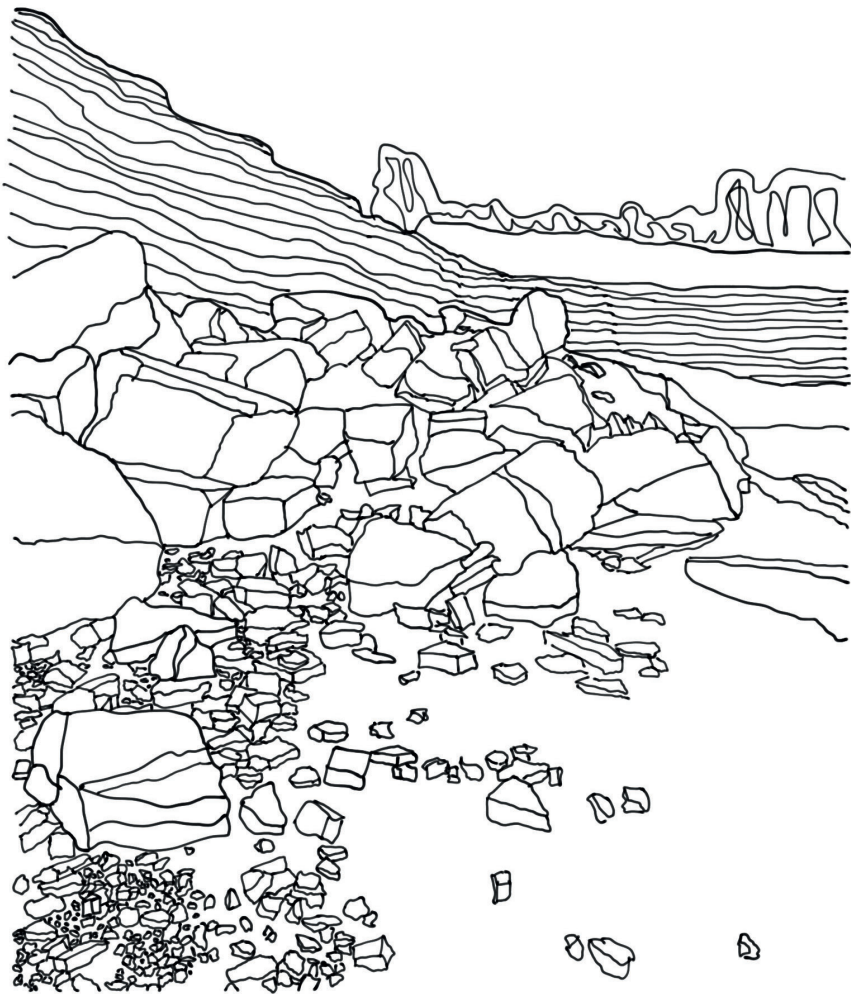

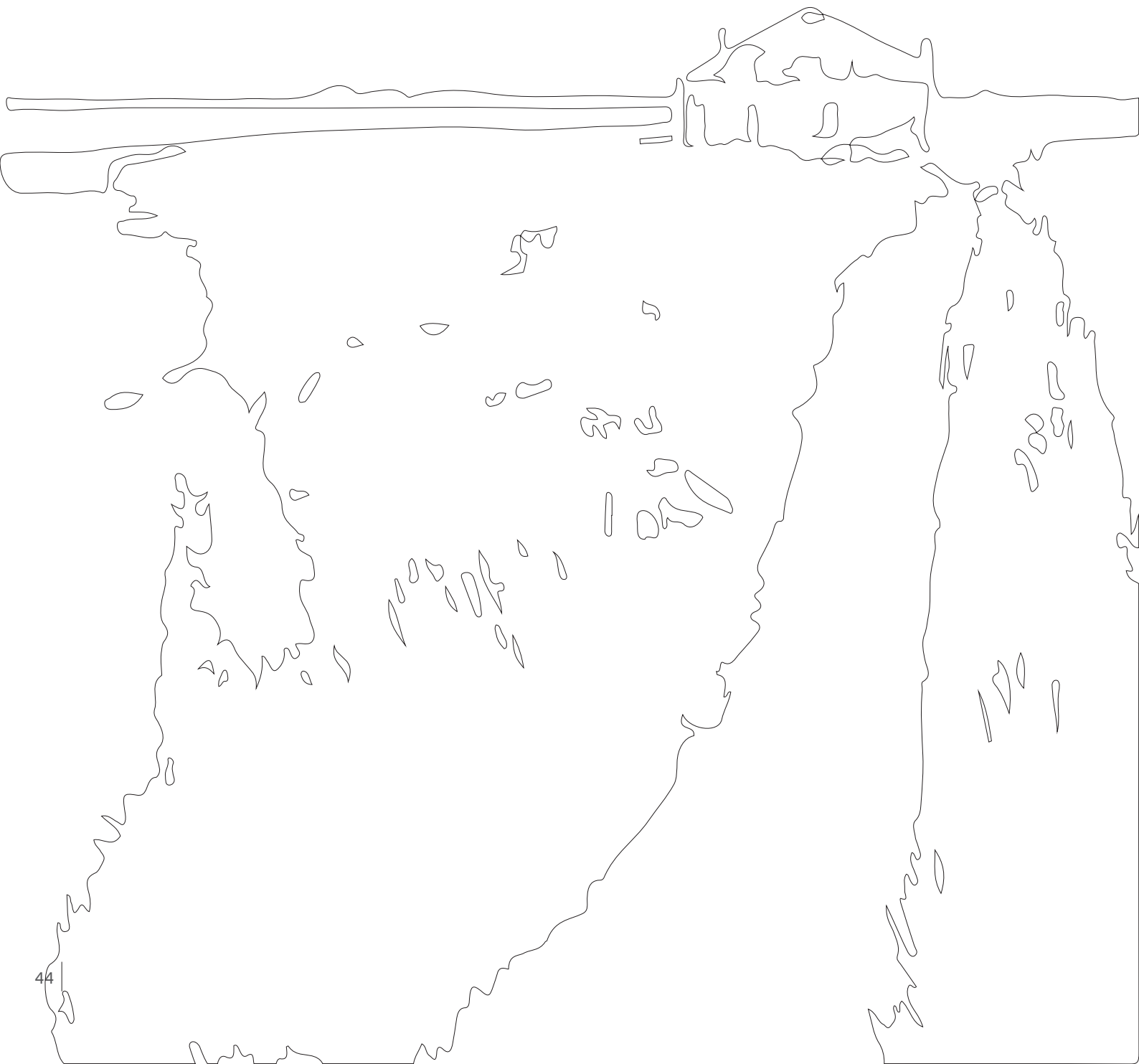

4. Design proposal

4.1 Concept

4.2 Situation

4.3 Building

4.4 Details

4.1 Concept

4.1.1 Design Criteria

As an aid for the design process several design criterias were developed in an iterative process going back and forth between theory - references - and design development.

Function

The building should function as a public visitors center for the Kinnekulle region. The need for a visitor center has been expressed by Götene municipality and ideas about what to include in the program were developed with input from the municipality as well as representatives from Platåbergens Geopark. The space should be designed with both visitors and staff in mind and be dimensioned for a moderate number of people due to seasonal fluctuations in number of visitors.

Materials & tectonics

Materials and construction should be connected to local building traditions on Kinnekulle and the building should in itself feel as part of the exhibition on the cultural history of the area. Construction should be carried out in close contact with the local community and employment of local craftsmen. Emphasis is to be placed on the contrast between heaviness / lightness - solidity / openness in the materiality.

Emphasis on the horizontal

The building should keep a low profile in the landscape without being sunken into the ground. The horizontal layers of limestone in the quarry should be reflected in the design of the building.

Foundation

The part of the building constructed in natural stone should feel as if though it was simply cut out from the bedrock underneath it and thus have close connection to the ground whereas the wooden part of the building should minimize the impact on the landscape by being placed on a plinth foundation thus enhancing the contrast between the heavy and the light.

4.1.2 Design Concept

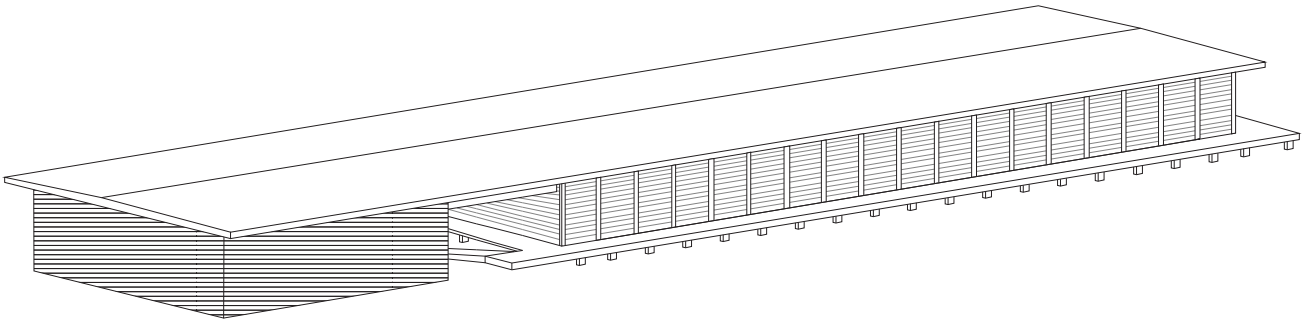

The program is divided into two volumes highlighting the contrast between solid and filigree construction. The volumes are connected by one large flat roof. The left, smaller volume, houses the main exhibition area and is made of natural stone walls. The right, larger volume, is constructed with an adapted post-and-plank timber structure. Between the buildings there is a gap which works as a transitional space and outdoors entrance area.

4.1.3 Structural Concept

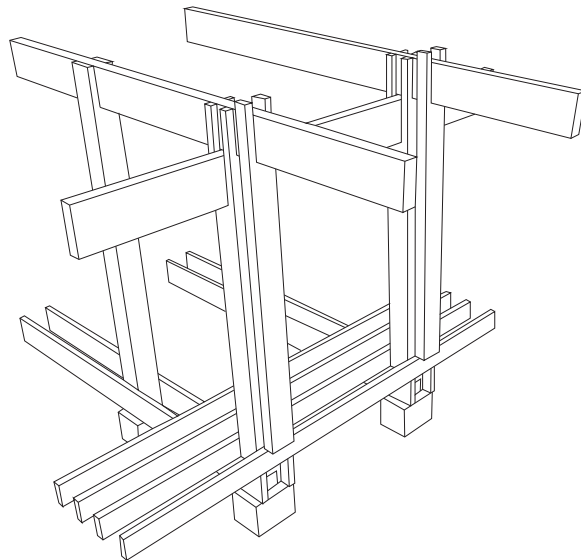

The structural concept is based on a post-and-beam construction with primary- and secondary roof glued laminated timber beams supported by glued laminated timber posts which end on a concrete plinth foundation. The floor beams are carried by two glued laminated timber suspension strands that are anchored on either side of the timber posts.

4.2 Situation

The visitor center sits on the south side of the quarry making the main point of access from the south and south-west. The elongated volume is seemingly anchored in the ground one side with the stone building appearing to be coming out of the ground, whereas the wood building is rather built on top of the rock and soil and is allowed to protrude over the edge of the hill extending the structure into the landscape.

The two volumes — one filigree — and one solid are connected through the large flat roof which created shielded areas for visitors to take a moments rest while taking in the scenery.

The aim has been to create a low - horizontal volume that doesn't stick out in the landscape but rather provides a sort-of platform for visitors to walk around on.



The building upon arrival on a sunny day in april





The building in the landscape during a rainy seen from the south-east

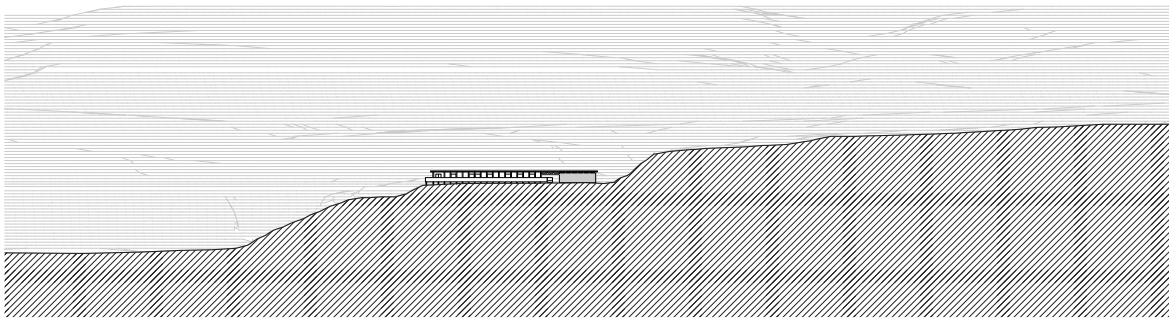
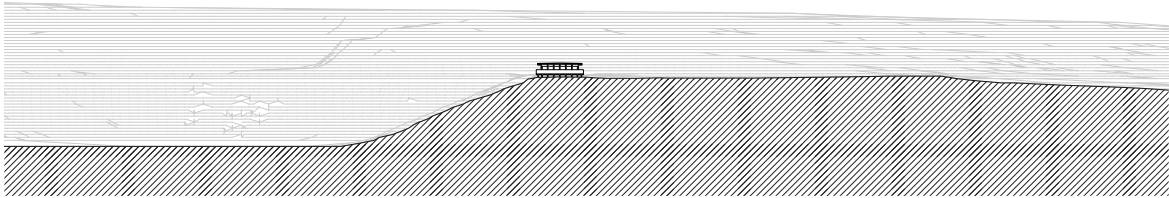

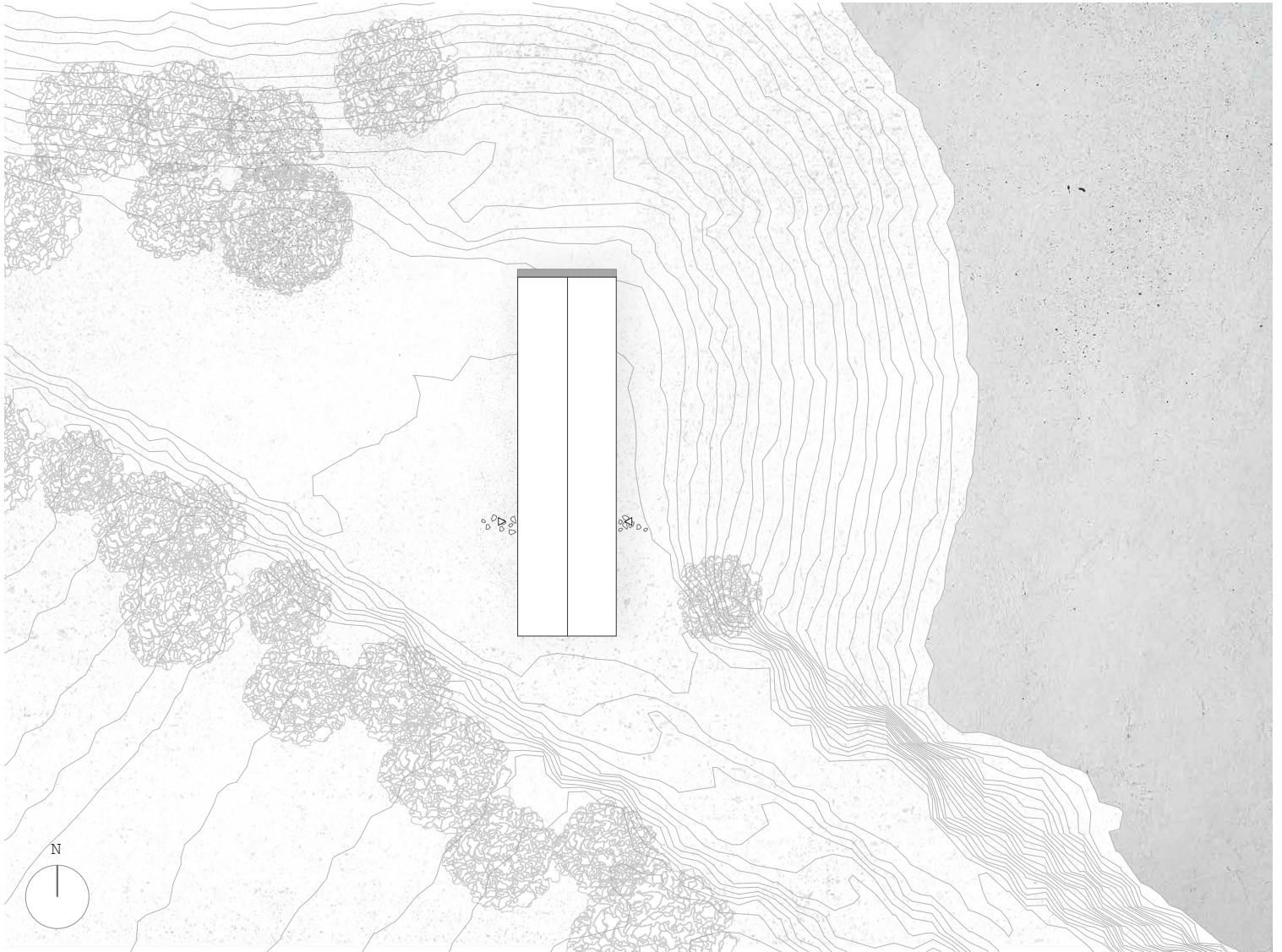

4.3 Building

The building is a proposal for a Visitor Center for the Kinnekulle region focusing on the unique geology of the mountain area and its related natural habitats and rich cultural history.

The volumes themselves serve as part of the exhibition through representing traditional building techniques from the region in natural stone and post-and-plank timber construction.

The stone building features raw surface finishes emphasizing the close connection to the bedrock on which it is built. The space is generous making it possible to host different kinds of exhibitions throughout the year.

The wooden building functions as the supporting building with a bistro for visitors to enjoy the beautiful scenery and staff to be able to carry out important communication and research activities.

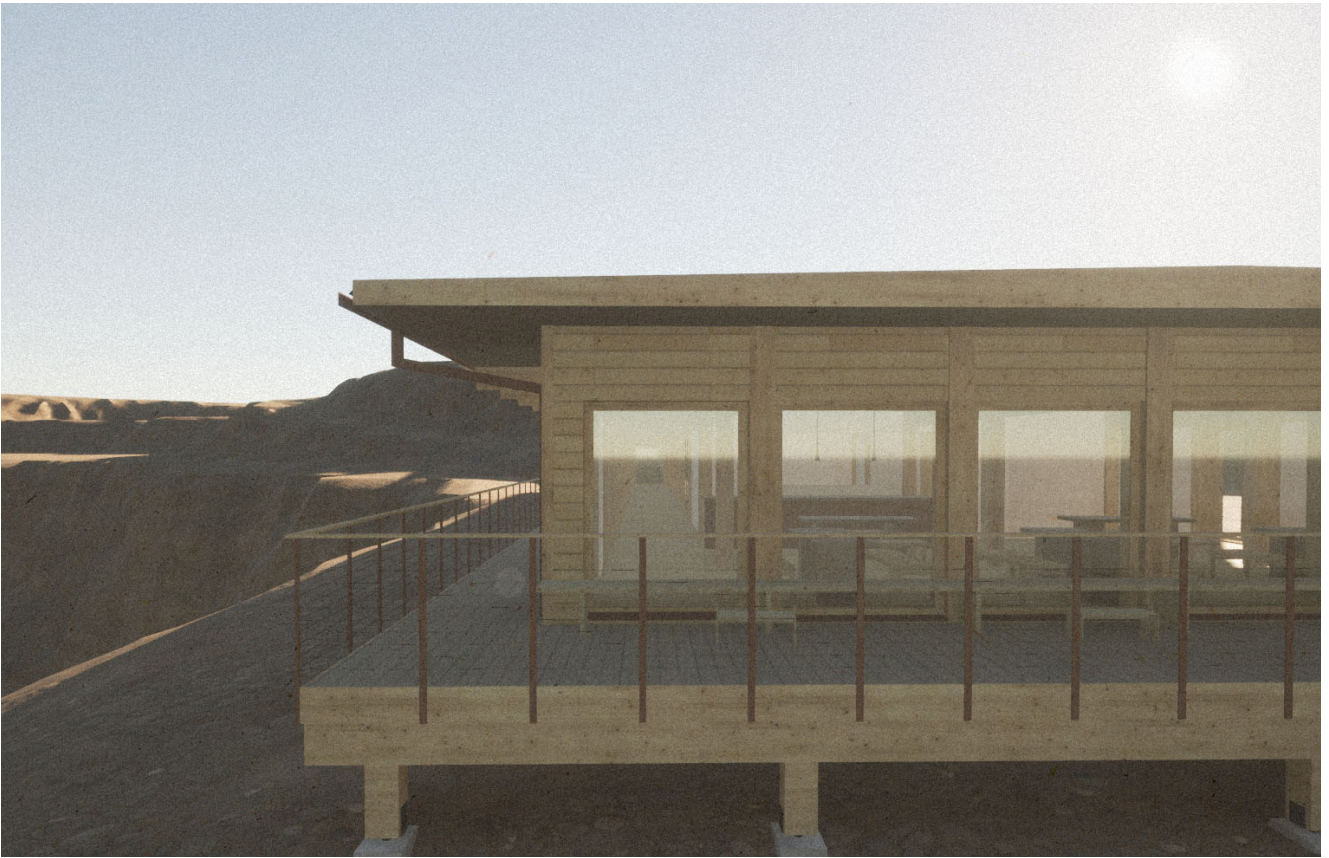

View from from the north towards the south over the terrace facing the surrounding scenery

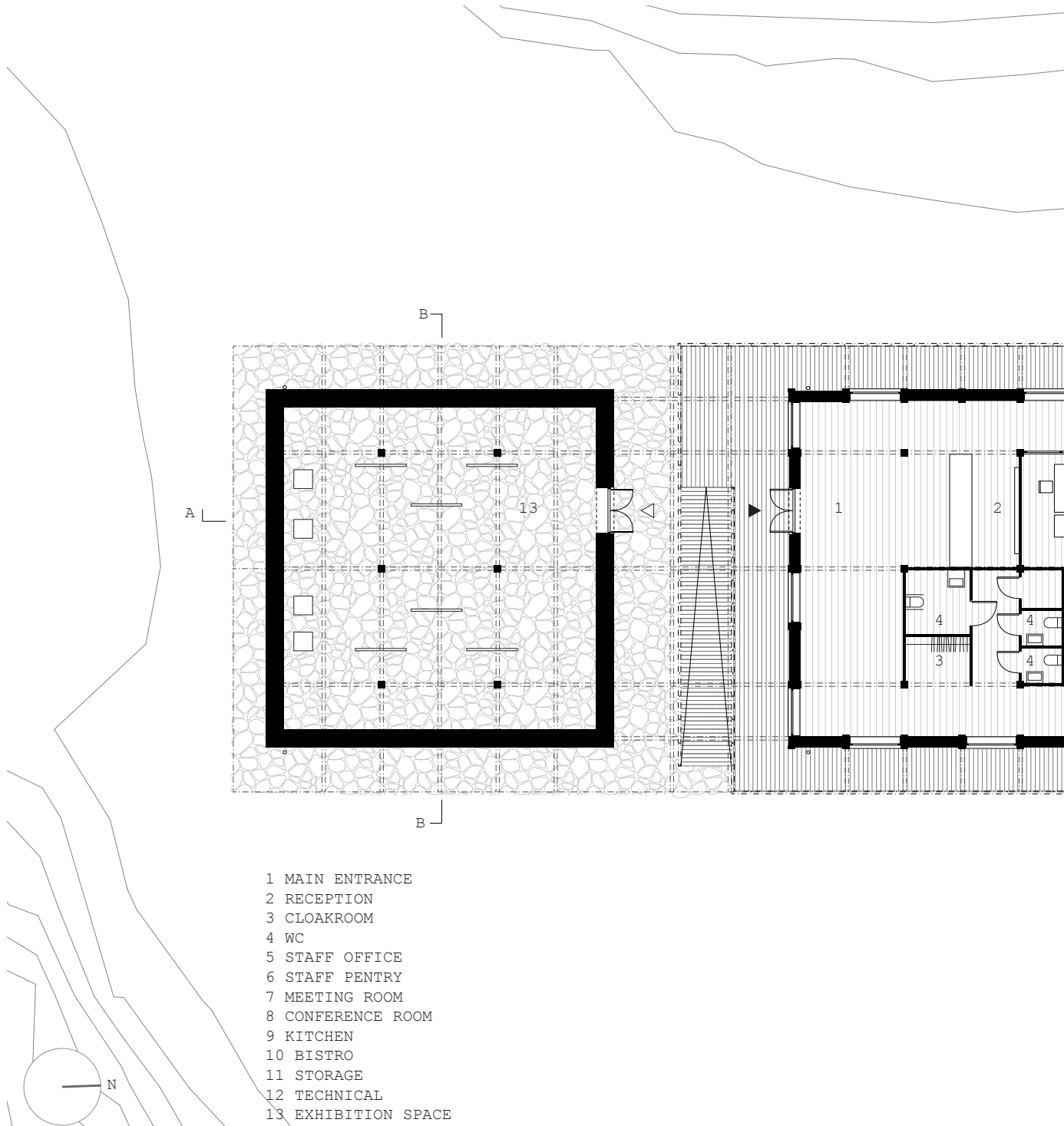

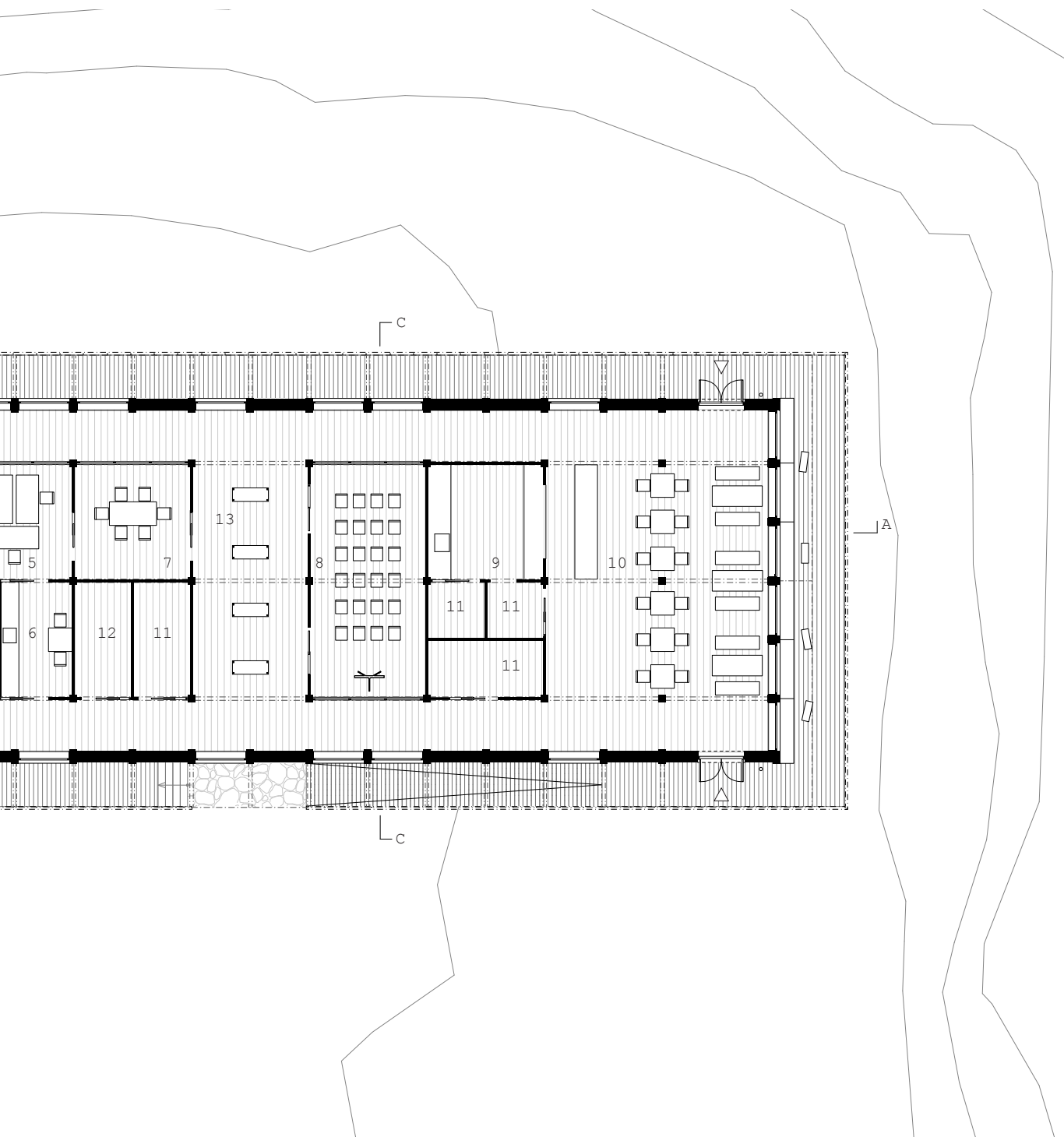



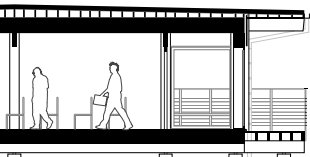
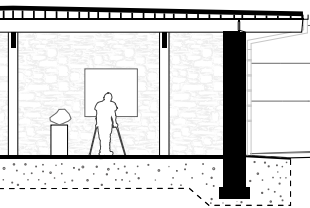
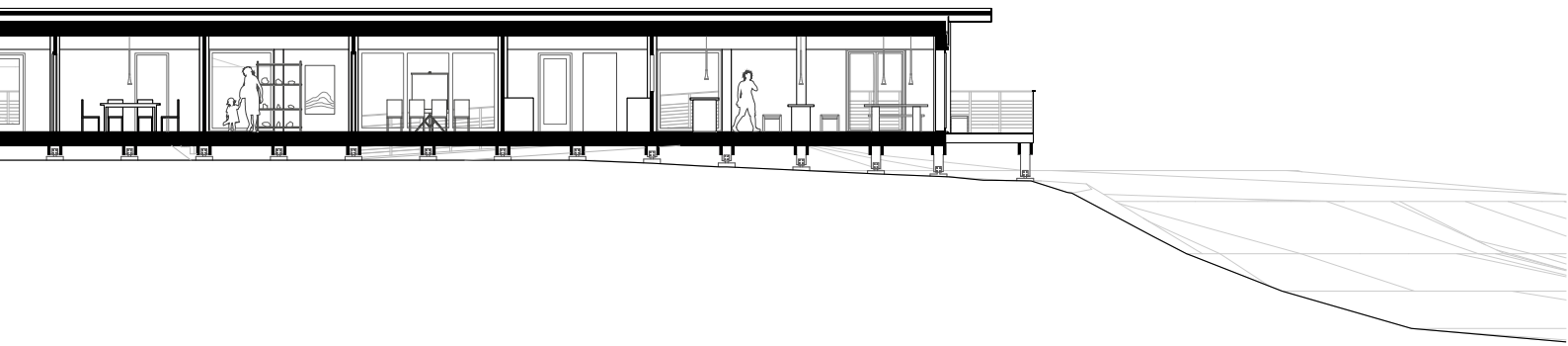

Middle: Cross section BB, scale 1_200 (A4) | Bottom: Cross section CC, scale 1_200 (A4)





Early evening view on the outside terrace

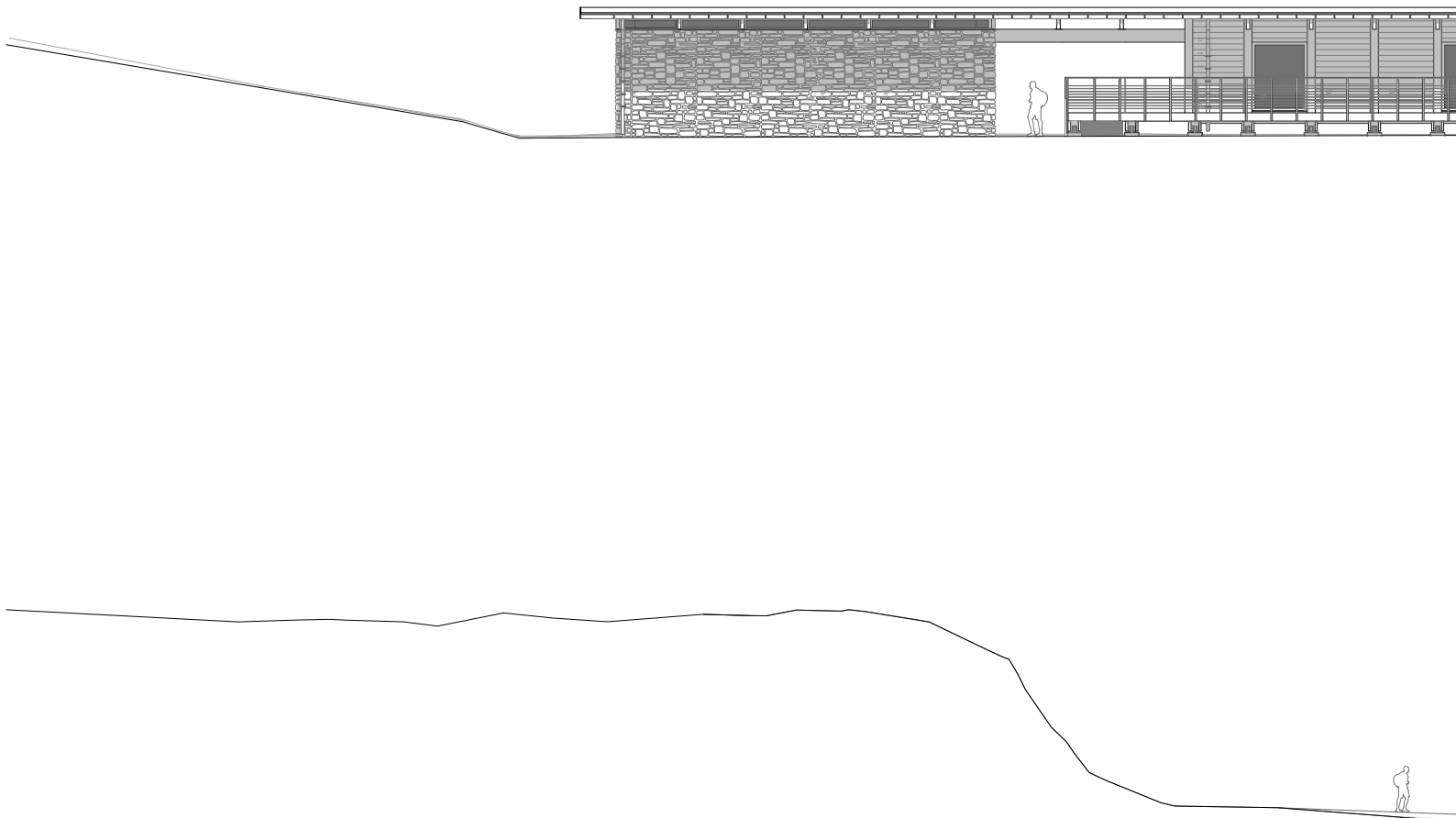

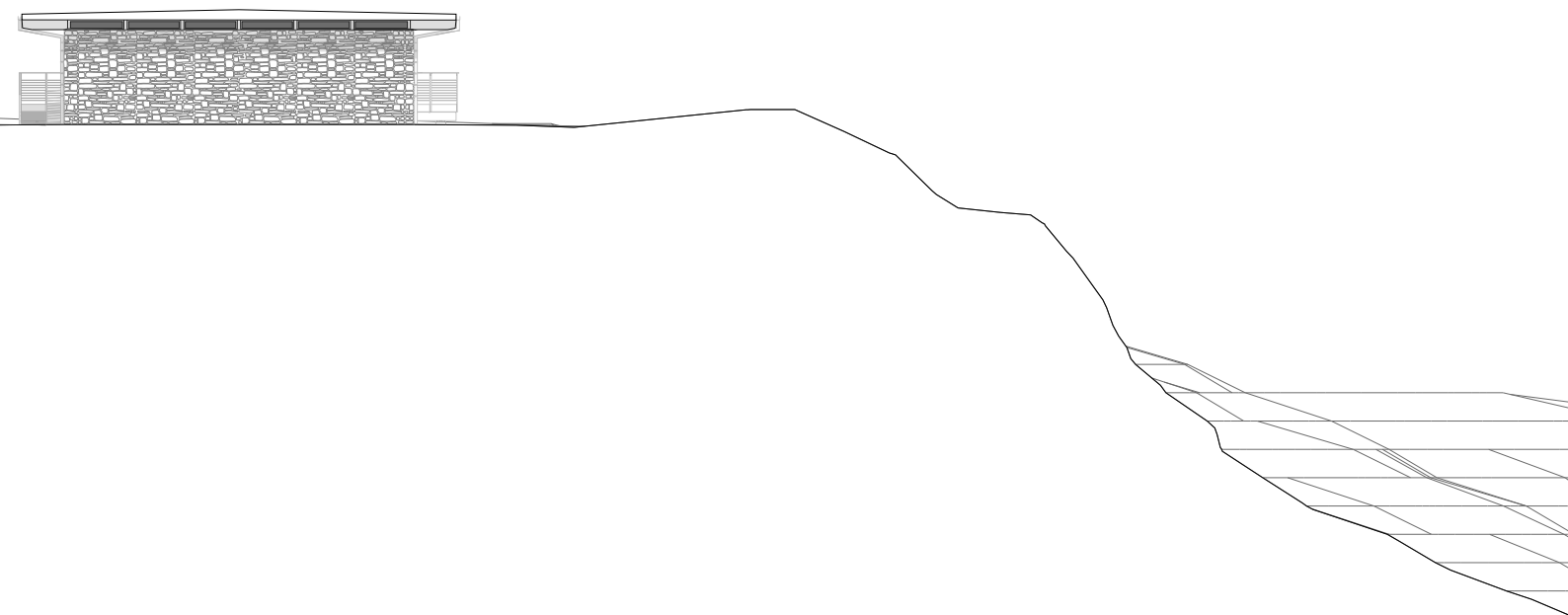
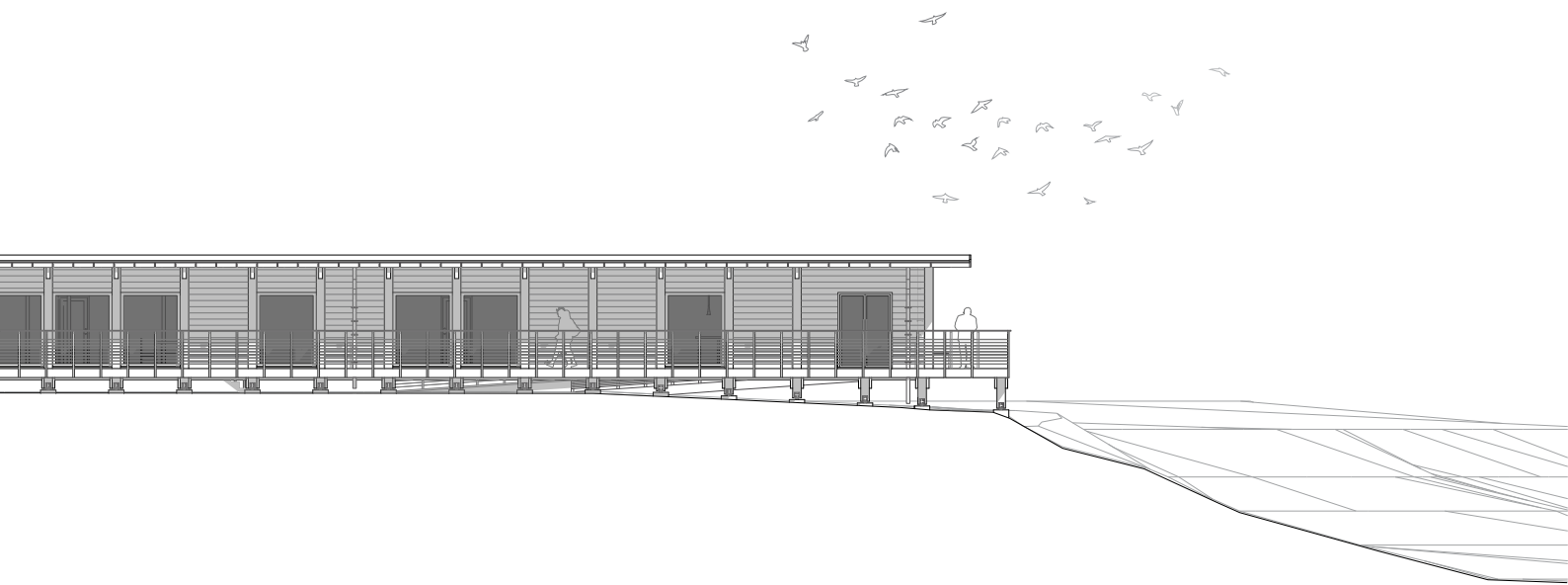

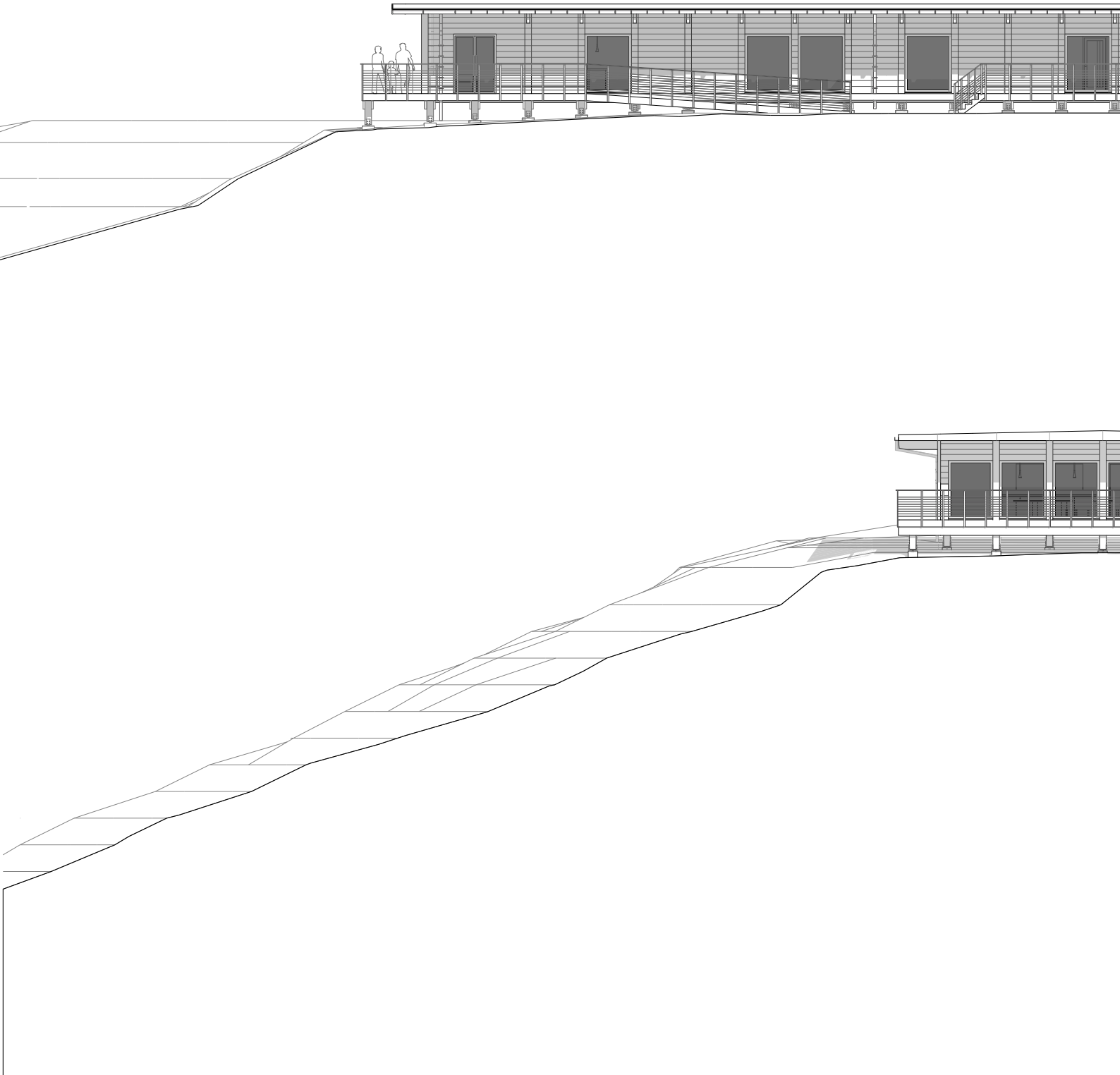

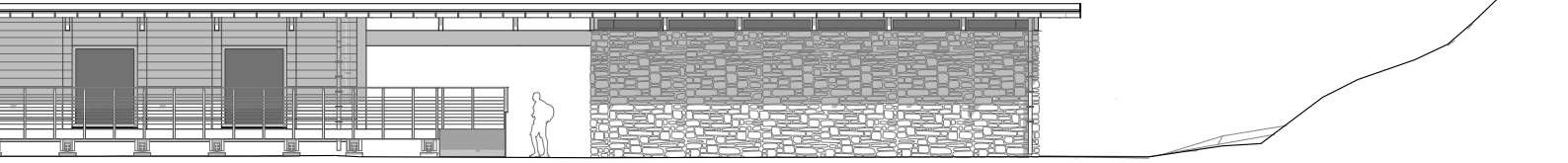

4.3 Detail





View of the exhibition area in the stone building

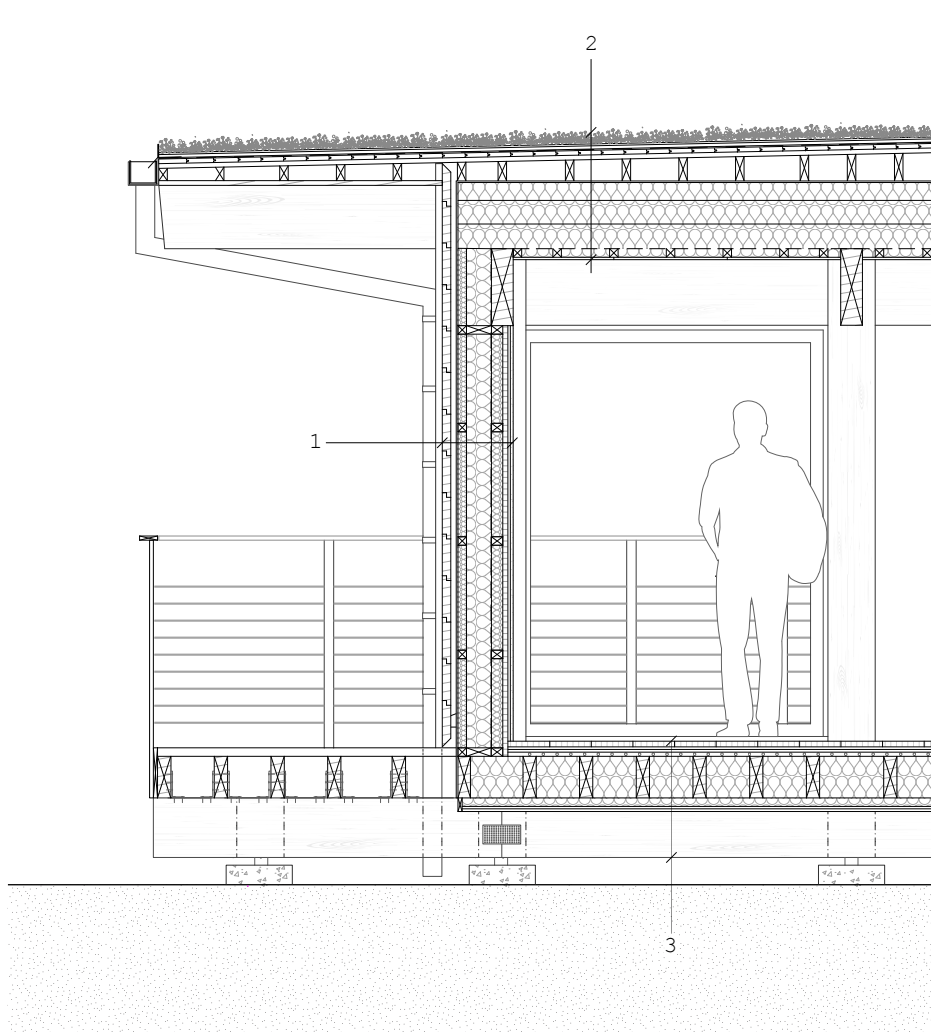

1.
 - Limestone Grout
 - Fire Protection Plasterboard
 - Stabilizing Plywood Sheet
 - Insulation Mineral Wool
 - + Horizontal Timber Joist
 - Vapour Barrier
 - Insulation Mineral Wool
 - + Vertical Timber Joist
 - Insulation Mineral Wool
 - Wind protective sheet
 - + Horizontal Timber Joist
 - Air Gap
 - Horizontal Facade Planks

2.
 - Wooden plank floor
 - Plasterboard Intermediate layer
 - Heat distributing sheet metal
 - Fibreboard / Under floor heating
 - Insulation Mineral Wool
 - + Floor Joist
 - Vapour Barrier
 - Insulation Mineral Wool
 - + Timber Studs
 - Plywood Sheet

3.
 - Limestone Grout
 - Fire Protection Plasterboard
 - Insulation Mineral Wool
 - + Timber Joist
 - Vapour Barrier
 - Insulation Mineral Wool
 - + Glulam Beam
 - Wind Protection Sheet
 - Roof Joist
 - Battens
 - + Air Gap
 - Tongue and groove board
 - Water protective layer (tarp)
 - Xerox-drainage
 - VT-felt
 - Sedum

15
13
27
60

2
130

45
3

35
45

30
12

16
22

220

2
45

27

10
13

45

2
360

3

70-220

25

24

7

17

10

30



Detail elevation, scale 1_40 (A4)

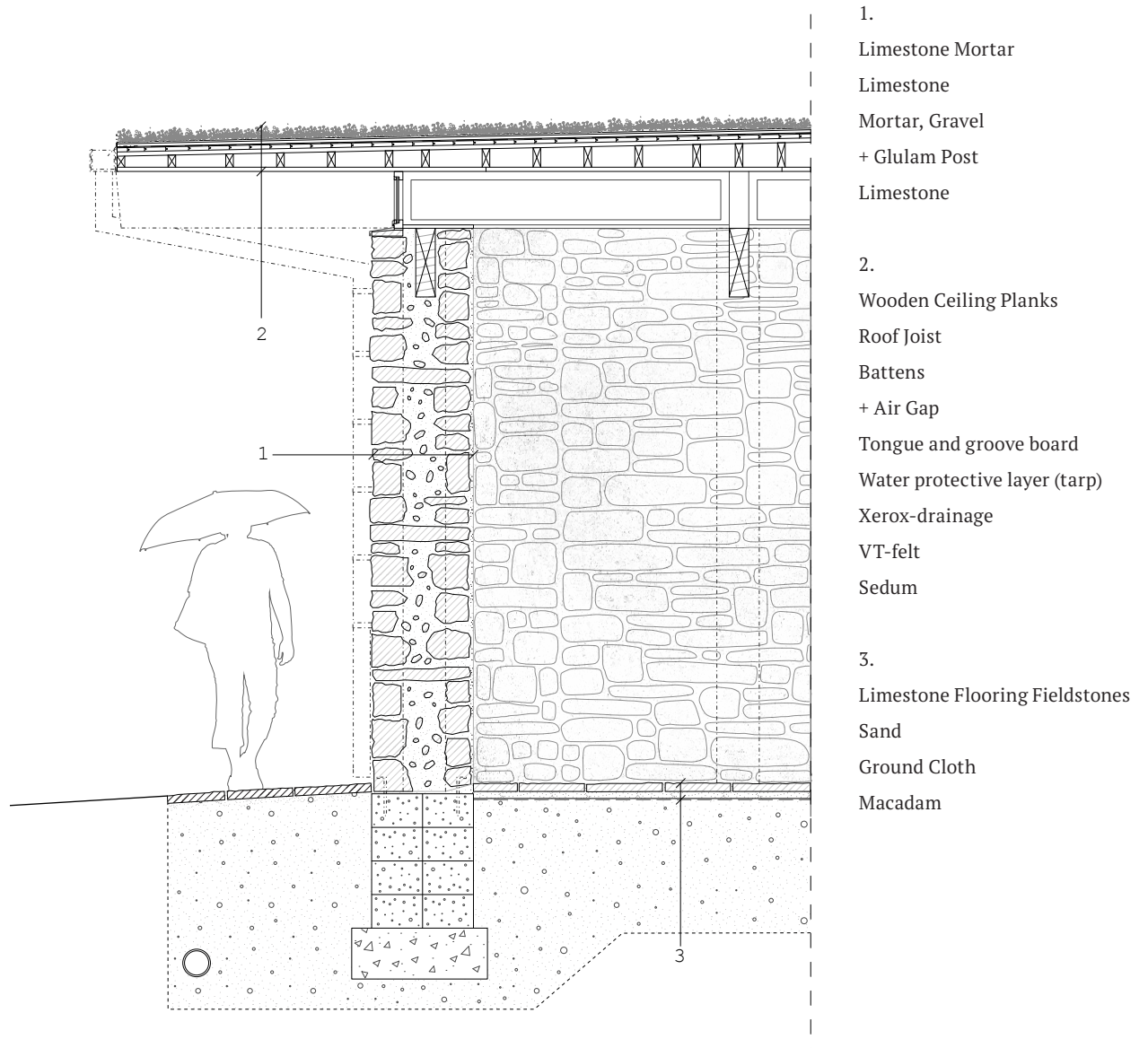

15
120
305
250
165



25
70-220
25
24
7
17
10
30
50
40





View towards the bistro area



5. Discussion

5.1 Conclusion

5.2 Reflection

5.1 Conclusion

The aim of this thesis has been to explore how a design of a building can connect to- and enhance the experience of a place and the cultural history of a region.

In the thesis I adapted the design theory and thinking of regionalism which advocates a strong connection to place through working with local materials and building traditions. Thus I researched what the local building tradition on Kinnekulle has been and found that it is a region with a longstanding tradition of building with natural stone as well as timber in particular post-and-plank construction,

Through an iterative process of doing sketches, digital- and physical modeling and drawings I applied what I had learned from theory, architectural reference projects and my studies on Kinnekulle in the design of a public visitor center at Stora Stenbrottet.

The project tells the narrative of building in and out of the ground with the stone that is available as well as building upwards with the timber that can be found in the forest. The goal for the design concept was to enhance both materials by contrasting them with each other and thus making the visitor aware of its connection to the site. Through referencing local materials and construction techniques the building itself works as an exhibition of the cultural history of Kinnekulle.

5.2 Reflection

The ambition with this master thesis has been to pay homage to a place that is very special to me personally. It is where I grew up and although I've since moved somewhere else, it still feels like home. I wanted to design something that had a strong tectonic connection to the context of Kinnekulle through using local materials and construction principles. I really didn't want the material to just be something that was added in the end as a facade cladding but rather something that was setting the tone and connecting everything in the entire project.

I initially started this thesis with the ambition to design the whole visitors center in natural stone but I struggled a lot with adapting it to modern building standards and whatever I did it just felt like a cladding and not at all like the traditional buildings on Kinnekulle - this eventually led to the decision to create two separate volumes - one insulated 'supporting' volume and one un-insulated exhibition volume. This thought then generated the idea about contrasting solid - filigree construction or stone - wood as it turned out but still having them connected through the large roof. However I still wanted the wooden building to connect to local tradition and thus I ended up doing a sort-of adaptation of post-and-plank construction.

A reflecting question could be how well-connected the building feels to the landscape of the particular site - much focus and emphasis in this thesis was on the tectonic aspect and figuring out how to design all the details and constructive elements. The building is linked to its location through referencing local building tradition but does the final design feel natural at the site — I myself am not convinced.

I've learned a lot about construction in both masonry and timber techniques and local cultural history in this thesis but I feel like this narrative could definitely be developed further and more in depth. Perhaps I will have the chance in the future to do so!

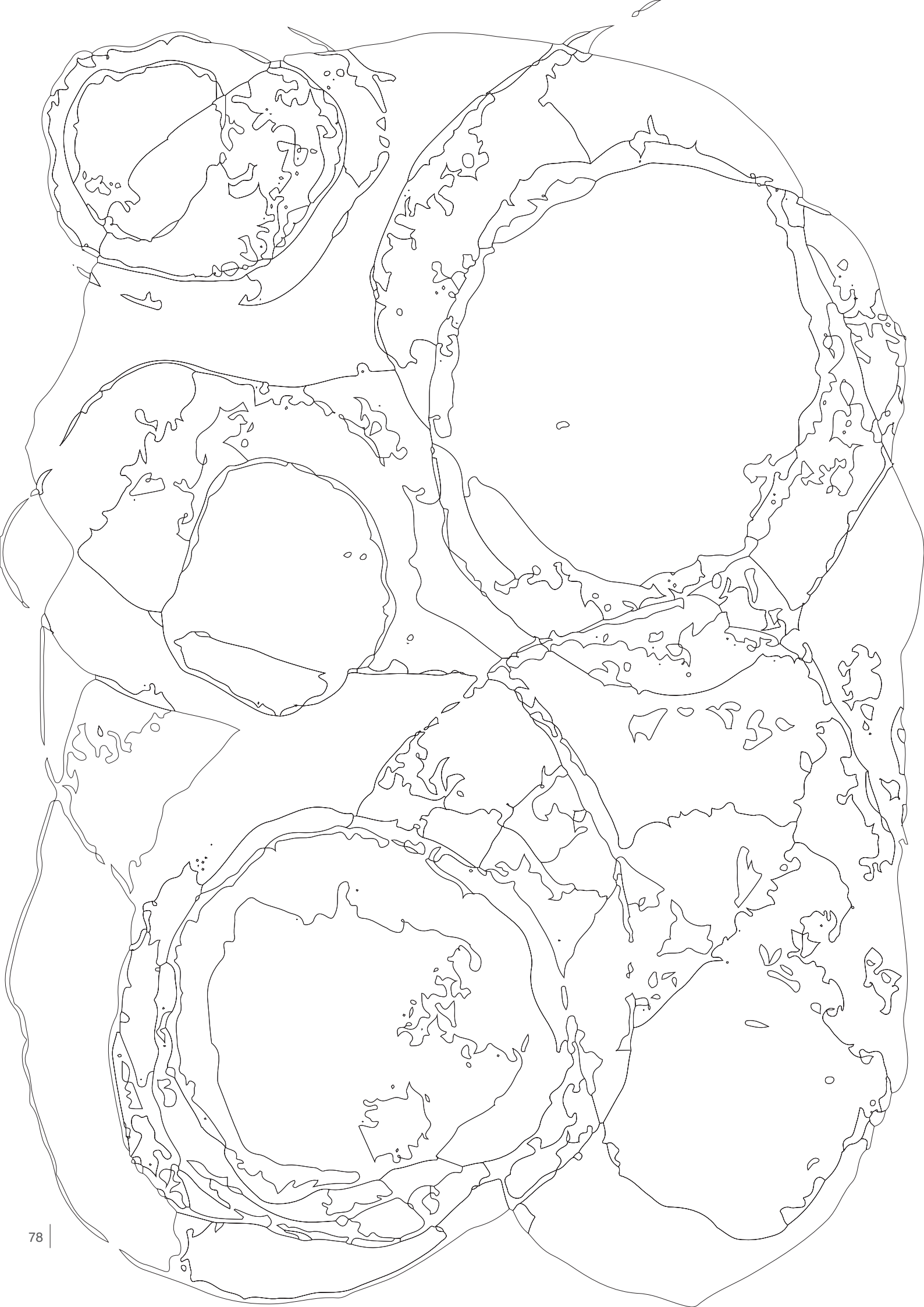

6. Bibliography

6.1 Literature

6.2 Figures

Bibliography

6.1 Literature

ArchDaily (2017). *Alpine Chapel Wirmboden / Innauer-Matt Architects*. Accessed through: <https://www.archdaily.com/874594/alpine-chapel-wirmboden-innauer-matt-architects> [11-03-2022]

ArchDaily (2021). *Boge Friggars House / Scott Rasmusson Källander*. Accessed through: <https://www.archdaily.com/954424/boge-friggars-house-scott-rasmusson-kallander> [09-05-2022]

Atlas of Places (2020). *Villa Schreiner*. Accessed through: <https://www.atlasofplaces.com/architecture/villa-schreiner/> [09-05-2022]

Bodin, A. (2016). *Arkitektens handbok 2016* (8., [rev.] uppl.). Studentlitteratur.

Borgström, H. (1957). *Stenhandboken : en handbok för arkitekter och byggnadstekniker*. Sveriges stenindustriförb.

Caminada A. G. & Aicher F. (2018). *On the path to building : a *conversation about architecture with Florian Aicher*. Birkhauser

Canizaro, V. B. (2007). *Architectural regionalism : collected writings on place, identity, modernity, and tradition*. Princeton Architectural Press

Deplazes, A. (2018). *Constructing architecture : materials, processes, structures* (Fourth, revised edition.). Birkhäuser.

Fotogrammetri. (n.d.) In *Nationalencyclopedia*. Accessed through: <https://www.ne.se/uppslagsverk/encyklopedi/l%C3%A5ng/fotogrammetri> [15-11-2021]

Glasner, B., & Ott, S. (2012). *Wonder Wood : A Favorite Material for Design, Architecture and Art*. Walter de Gruyter GmbH.

Gustavsson, T. (2012). *Moderna tegeldetaljer : med teglets materialitet som utgångspunkt* (Revised edition). Arkitekternas forum för forskning och utveckling (Arkus).

Hauberg, J. (2011). Research by design : a research strategy. *Architecture & Education Journal*, 2011(5), pp. 46-56
Accessed through: https://www.researchgate.net/publication/279466514_Research_by_design_a_research_strategy [20-10-2011]

Henriksson, G. (2008) *Skiftesverk – när – var – hur*. Byggnadsvårdsföreningen. Accessed through: <https://byggnadsvard.se/skiftesverk-nar-var-hur/> [10-05-2022]

Hoffmann, A. R. (2020). *Sketching as design thinking*. Routledge, Taylor & Francis Group.

Jormakka, K., Schürer, O., & Kuhlmann, D. (2013). *Basics Design Methods*. Walter de Gruyter GmbH.

Khatib, J. M. (2016). *Sustainability of construction materials* (Second revised edition.). Woodhead Publishing.

Lowen Widman Arkitekter (n.d.) *Kroklada Öland*. Accessed through: <https://www.lowenwidman.se/projekt/kroklada/> [2022-05-05]

Länsstyrelsen Västra Götaland. (n.d.) *Kinneulle*. Accessed through: <https://www.lansstyrelsen.se/vastra-gotaland/besok-smal/naturreservat/kinnekulle.html> [15-11-2021]

Platåbergens Geopark. (2018) *Kinneulle*. Accessed through: <https://www.platabergensgeopark.se/en/the-geology/> [10-05-2022]

Schulz, A., Schulz, B., Albus, J., & Hauger, S. (2020). *Manual of natural stone : modern usage of a classic building material*. Edition Detail.

Sveriges Stenindustriförbund (2005). *En handbok om natursten*. Sveriges stenindustriförbund.

Västsverige. (n.d.) *Kinnekulle - det blommande berget*. Accessed through: <https://www.vastsverige.com/lackokinnekulle/kinnekulle/> [15-11-2021]

Werner, M. (2011). *Model Making*. Princeton Architectural Press.

Zumthor, P. (2006) *Atmospheres : Architectural environments ; surrounding objects*. Birkhäuser.

6.2 Figures

All non-referenced images and illustrations are works of the author.

- Fig. 1. Bereuter, A. (2017). *Alpine Chapel Wirmboden / Innauer-Matt Architects* [digital images]. Accessed through: <https://www.archdaily.com/874594/alpine-chapel-wirmboden-innauer-matt-architects> [15-11-2021] © Adolf Bereuter / *Used with permission from the photographer*
- Fig. 2. Lowen Widman Arkitekter (n.d.). *Kroklada Öland* [digital images]. Accessed through: <https://www.lowenwidman.se/projekt/kroklada/> [05-05-2022] © Lowen Widman Arkitekter / *Used with permission from the studio*
- Fig. 3. Teigens Fotoatelier. (1963-1965). *Arkitekturfoto av Villa Schreiner* [digital image]. Accessed through: <https://digitaltmuseum.org/011012602679/schreiner> [05-05-2022] © Teigens Fotoatelier / Creative Commons Licence - *Attribution 4.0 International (CC BY 4.0)*
- Fig. 4. Sundström, A. (2019). *Boge Friggars House* [digital images]. Accessed through: <https://www.archdaily.com/954424/boge-friggars-house-scott-rasmusson-kallander> [05-05-2022] © Anna Sundström / *Used with permission from the photographer*
- Fig. 5. Västergötlands museum. (n.d.) *Lada skiftesverk* [digital image]. Accessed through: <https://digitaltmuseum.org/021017221751/1m16-b145291-346> [10-05-2022] © Västergötlands museum / Creative Commons Licence - *Attribution-NonCommercial-NoDerivatives 4.0 International (CC BY-NC-ND 4.0)*



CHALMERS
UNIVERSITY OF TECHNOLOGY