



**CHALMERS**  
UNIVERSITY OF TECHNOLOGY

---



# DESIGNING A HANDLE FOR THE TRANGIA STOVE

Master Thesis in Industrial Design Engineering

Victor Bergh Alvergren  
Karin Karlsson

---

Department of Product and Production Development  
Chalmers University of Technology  
Gothenburg, Sweden. 2017



Master Thesis in Industrial Design Engineering

# **Designing a Handle for the Trangia Stove**

Victor Bergh Alvergren  
Karin Karlsson

Examiner and supervisor: Håkan Almius

Master of Science Thesis PPUX05

**Designing a Handle for the Trangia Stove**  
Master thesis in Industrial Design Engineering

© Victor Bergh Alvergren & Karin Karlsson

Chalmers University of Technology  
SE-412 96 Göteborg, Sweden  
Telefon +46(0) 31-772 1000

Cover photo: Victor Bergh Alvergren

# FOREWORD

This report concerns the Master Thesis “Design of Pan Grip for Trangia Camping Stoves” which was conducted during spring 2017 for Trangia AB at the Department for Product and Production Development, Chalmers University of Technology. It was conducted by two students at Industrial Design Engineering at full time.

Throughout the process, many people have been very kind and helpful and provided invaluable input to the design. Some of them will be thanked here. Thanks to our supervisor and examiner Håkan Almius, who always have been very interested and helped us to get on the right track when lost. Thanks to Bengt Jonsson, CEO of Trangia, who have been very supportive and provided many valuable discussions and decisions.

Thanks to all participants in our tests and studies who have helped us with so much information, and especially the employees at Husqvarna in Jonsered who kindly let us investigate and test out ideas at their many storm stove lunches. Thanks to all the administrators for Facebook groups, societies and utsidan.se who helped us to get in touch with their members. We also want to thank all the plastic retailers who helped us to obtain test pieces for our material study.

Thanks to Rasmus at Lernia who helped to make an aluminium model of our final concept, and Alexander at Chalmers Robotics who helped us cut out the profile with a laser cutter. Thanks to all the professors and other employees Antal, Fredrik, Roger, Håkan, Gustav, Johan and Ulf who kindly supplied us with their knowledge to obtain a product as good as possible. Finally, thanks to our opponents Karin and Katarina who have provided many interesting discussions and insights throughout the entire process.

# ABSTRACT

This thesis report concerns the development of a new detachable pan grip for Trangia camping stoves. The aim was to reduce the handle's tendency to harm the non-stick coatings and pot surfaces as well as to minimize the risk of thermal burns caused by the handle. Furthermore, the thesis was to investigate user needs and possible alternative materials in order to increase the overall functionality of the handle.

Theory and mechanical analyses showed that the main reasons why the handle scratch the pot surfaces concerned the rivet, plier mechanism and design of the jaws in combination with the hardness of the aluminium oxide. A material study was conducted to find materials that could reduce the thermal conductivity and scratch tendencies of the handle. The study identified three possible alternatives; stainless steel and the polymers PPS and PEEK. However, tests and analyses showed that none of these materials would fulfil the necessary requirements. The new handle was therefore developed to be made out of stamped and bent aluminium parts.

A vast user study regarding the stoves' entire use situation was conducted. Extensive amounts of data were analysed and summarized into specific requirements for the handle. Key findings show that users must be able to place a high degree of trust in the handle's durability and functionality, the handle must be comfortable to hold and the risk of pinching, burns or dropping pots must be minimized.

The concept development consisted of three phases. The first phase explored form and function, and resulted in five handles that were 3d-printed and tested on users. These were reduced to two concepts during the second phase where material and manufacturing constraints were added to the ideation. The concepts were evaluated using the same method as the first concepts. In the final phase one of the concepts were refined in terms of manufacturability, usability and heat conductivity.

The new handle replaces the classic plier mechanism with a slanted rail. This handle minimizes scratching by distributing pressure across larger contact surfaces and allowing the jaws to slide into place without causing local pressure points. Furthermore, the handle removes the risk of pinching and provides the users with a comfortable and safer grip when lifting pots.



# INDEX

CHAPTER 01 - INTRODUCTION	01
1.1 Background	02
1.2 Aims and objectives	03
1.3 Initial demarcations	03
CHAPTER 02 - PRODUCT ANALYSIS	05
2.1 Stove constructor	06
2.2 Manufacturing	09
2.3 Scratch analysis	10
2.4 Temperature analysis	13
CHAPTER 03 - MARKET ANALYSIS	15
3.1 Competitor handles	16
3.2 Brand analysis	21
CHAPTER 04 - USER STUDIES	23
4.1 User study method	24
4.2 User study results	25
4.3 SWOT Analysis	30
4.4 Personas	32
CHAPTER 05 - MATERIAL STUDIES	35
5.1 Method	36
5.2 Potential materials	36
5.3 Material simulations	39
5.4 Material tests	40
5.5 Conclusions	43
CHAPTER 06 - REQUIREMENTS	44
6.1 Handle functions	45
6.2 Construction	45
6.3 Material damages	46
6.4 Miscellaneous	46

CHAPTER 07 - FIRST CONCEPTS	47
7.1 Concept Development	48
7.2 Concept Presslock	49
7.3 Concept Downslide	51
7.4 Concept Springslide	53
7.5 Concept Pinlock	55
7.6 Concept Snapbutton	57
7.7 Concept testing	60
7.8 Conclusions	62
CHAPTER 08 - SECOND CONCEPTS	
8.1 Concept refinement	64
8.2 Concept Gripslide	65
8.3 Concept Plier	68
8.4 Evaluation	70
CHAPTER 09 - FINAL PRODUCT	75
9.1 GlideLifter	76
9.2 Development	82
9.3 Mechanical properties	82
9.4 Manufacturing	83
9.5 Sustainability	84
9.6 Evaluation	85
9.7 Next step	85
CHAPTER 10 - DISCUSSION	87
10.1 Attached handles	88
10.2 Plastics	88
10.3 Sustainability and ethics	89
10.4 Holes and patterns	89
10.5 Multi-tool handles	90
10.6 Requirement fulfillment	90
CHAPTER 11 - REFERENCES	91
APPENDICES	96



# 01

## INTRODUCTION

This thesis report concerns the development of a new pot handle for Trangia Camping Stoves by the aid of New Product Development. The project was initiated by Trangia and executed as a full-time master thesis by two students at Industrial Design Engineering, Chalmers University of Technology, during spring 2017

# 1.1 BACKGROUND

Trangia AB was founded 1925 in the village of Trångsviken, Jämtland, as a manufacturer of aluminium pans for household use. The name was chosen to reflect the identity of the village as well as the use of aluminium by the ending "ia". With growing demands for outdoor cooking, the classic Trangia stove was released to the public in 1951. The stove is based on the Trangia principle, with a rigid windscreen split in two parts. The lower part is ventilated on one side to supply the burner with air, while the upper is airproof and submerges the pots to protect them from wind. Altogether the stove consists of a burner, a set of two pots and one frying pan, windscreens, a strap and a detachable pan grip. During storage, the parts are placed within each other, allowing the entire system to occupy a small volume.

Trangia Stoves have since been enjoyed by campers and explorers alike for their durable and reliable qualities, as well as clever storage solutions. Almost 70 years later, the basic principle still holds, and the product has only undergone minor changes. However, there are parts of the stove that may be improved. Trangia have identified several problems with the detachable pan grips used to hold the pots. The jaws were found to scratch non-stick frying pans, and both overall functionality and aesthetic appeal could be improved. As the handle has not been modified since the 1950s, Trangia was looking to develop a new handle that fulfills these requirements, as well as unexplored latent needs from the users. Furthermore, Trangia wished to explore the possibilities of manufacturing the handle in heat-resistant plastic materials.

## 1.2 AIMS AND OBJECTIVES

The aim of this thesis is to find a new solution for holding and carrying Trangia pots, that satisfies the users' needs and minimizes the risk of harming the non-stick coating. The new handle should reduce the risk of users getting burns and withstand the heat generated by the stoves. While the main focus is on the handle, changes to other parts of the stove may be suggested if the redesign of the handle demands it.

The objective is to develop a product that better satisfies the needs and requirements of the handle, and increase the positive user experience gained from using the camping stove. The handle should also fit the tradition and brand identity of Trangia.

## 1.3 INITIAL DEMARCATATIONS

The following demarcations were chosen as means to frame the project scope.

- The handle shall be designed for use on existing Trangia 25 and 27 stoves
- The handle shall be detachable and possible to use on all Trangia pots and pans
- The handle shall be possible to store within the stove
- The solution shall work with the existing burners
- The project will be based on user studies conducted in Sweden, with Swedish subjects



# 02

## PRODUCT ANALYSIS

This chapter will provide an overview of the Trangia stove system and product context. It will also describe the manufacturing process of the products. The handle is then subjected to tests and analysis aimed at identifying and describing the underlying causes for why the handles scratch and dent the pots. Finally, the handle's temperature distribution and changes during use are investigated.

# 2.1 STOVE CONSTRUCTION

The Trangia stoves are divided into the Trangia 25, 27 and Mini (28) series. The different series differ in size, with the 25 series being the largest, aimed at preparing food for groups of 3-4 people. The 27 is similar to the 25 but serves a smaller group of 1-2 people, while the Mini is a much smaller stove made for solo use. Mini also has different handle than the others.

There are different variants within the 25 and 27 series, which differ in terms of materials as well as inclusion or exclusion of the kettle. Another variable is the fuel source; the traditional spirit burner is included as a standard but Trangia also offer gas, multifuel and gel burners.

The focus of this analysis has been one of the most common models, the Trangia 25-4, which was used throughout the thesis. This model consists of two pots, a non-stick frying pan, a kettle, windscreens, a spirit burner, a detachable grip handle and a strap. All parts are made out of aluminium except the burner, strap and the frying pan's nonstick-coat.

## THE POTS

The two pots have volumes of 1.75 and 1.5 litres respectively, and are slightly tapered at the bottom. See Figure 2.1 for image. The smaller pot has engraved fluid measurements on the outside, grading the water level at 0.5 and 1 litre. These pots have curled edges but because of manufacturing constraints other Trangia pots, such as the duossal pots, have bent edges instead. When stored, the smaller pan is placed inside the larger.



Figure 2.1 The large pot.

## THE FRYING PAN

The frying pan acts as a regular frying pan as well as a lid for the pots, see Figures 2.2 and 2.3. It is manufactured from non-stick coated aluminium to allow the pan to be easily cleaned. As the coating is vulnerable towards scratches, it is delivered with a see-through plastic cover for protection. When the stove is packed, the frying pan closes the kit by acting as a lid above the windscreen and pots.



Figure 2.2 The frying pan.



Figure 2.3 The plastic protector

## THE KETTLE

The kettle consists of a 0.9 litre water chamber, a spout for pouring, a lid and a handle. See Figure 2.4 for image. The lid has a plastic knob and the handle is covered with a removable plastic cover to protect against the heat. The kettle fits tightly inside the smallest pot, with its inner chamber providing storage for both handle and burner.



Figure 2.4 The kettle

## THE SPIRIT BURNER

The spirit burner consists of a brass cylinder with two lids; a closing lid and a simmer ring for controlling the intensity of the flame, see Figure 2.6. A textile wick is mounted inside the burner to aid the burning process. In order to avoid corrosion and leakage, the burner is stored in an accompanying yellow and red plastic bag. Additionally, there are use instructions and warnings printed on the bag.



Figure 2.6 The Spirit Burner

## THE WINDSCREEN

The windcreens consist of two parts; the upper and the lower, see Figures 2.7 and 2.8. The lower half has a series of circular holes on one side to enable air intake and slightly reduce the weight. A larger hole serves as an outlet for gas and multifuel hoses, and two loops act to secure the locking strap. The top of the lower windscreen consists of a raised perforated platform. At the side of the platform there are fastenings for the upper windcreens. The burner is mounted in the large hole at the centre, and the smaller surrounding holes provide airflow from below.



Figure 2.7 The upper windscreen

The upper half is mounted on the lower using a bayonet grip. The upper windscreen does not have any perforations or holes; instead it encloses the flames and contains the heat. A metal wire is attached to the inside of the windscreen, on which the three pot holders are fastened. The pot holders are turned downwards for using pots and kettles, and upwards for frying pans or larger extra pots. The lower half of the windscreen is stored upside down with the upper half inside it. The pots are then placed inside the upper windscreen.



Figure 2.8 The lower windscreen

## THE STRAP

The product is secured by a textile strap with a metal buckle, see Figure 2.9. The strap is pulled through the loops at the sides of the windscreen, and tightened with the buckle. Moreover, it also acts as a handle for carrying the stove.



Figure 2.9 The strap

## DETACHABLE GRIP HANDLE

The pot handle uses a plier mechanism and consists of one lower and one upper part that have been attached using a rivet. See figure 2.10. The front end consists of two jaws, used to grab hold of the pot edges. The jaws are shaped to match the edges and provide a tight and secure grip. The contact surfaces between the jaws and pots are the rough edges that occur during stamping, and are no wider than the material thickness of 2 mm.



Figure 2.10 The handle

The gripping surfaces of the handle extends around 90 mm from the jaws. The upper and lower part have similar u-profile shapes that fit into each other when closing. The handle is perforated with a series of circular holes to reduce weight and provide faster cooling. When attached to a pot, the lower part of the handle will automatically fall down and thereby open the handle, unless something is holding it up. Otherwise, the handle is easy to open and close and does not close askew.



Figure 2.11 Jaw and gripping surfaces of the Handle



Figure 2.13 The packed and unpacked stove

## 2.2 MANUFACTURING

The products are fully manufactured and assembled in Trangia's facilities, save for plastic details that are ordered from elsewhere in Sweden. Materials are obtained in the form of round plates in different sizes, called roundabouts, or metal sheets on a roll. The metal is punched and bent in Trangia's own machine park to create the products. Manufacturing is rather automated, with assembly being done manually with the aid of tools or machines.

The handles are manufactured from metal rolls, which are stamped out in three steps by a large press machine to form the basic shape. About 30% of the metal sheet is cut away between the part, and a total 35% is cut away when considering the holes. See Figure 2.14 for image.

The parts are bent in a machine to achieve the U-profile shape, and stamped with the Trangia logotype. Handles are then manually assembled, by placing the main parts inside each other, lubricating a rivet with oil and inserting it from the side. The rivet is bolted together by a manually controlled machine in which every handle is inserted on its own.

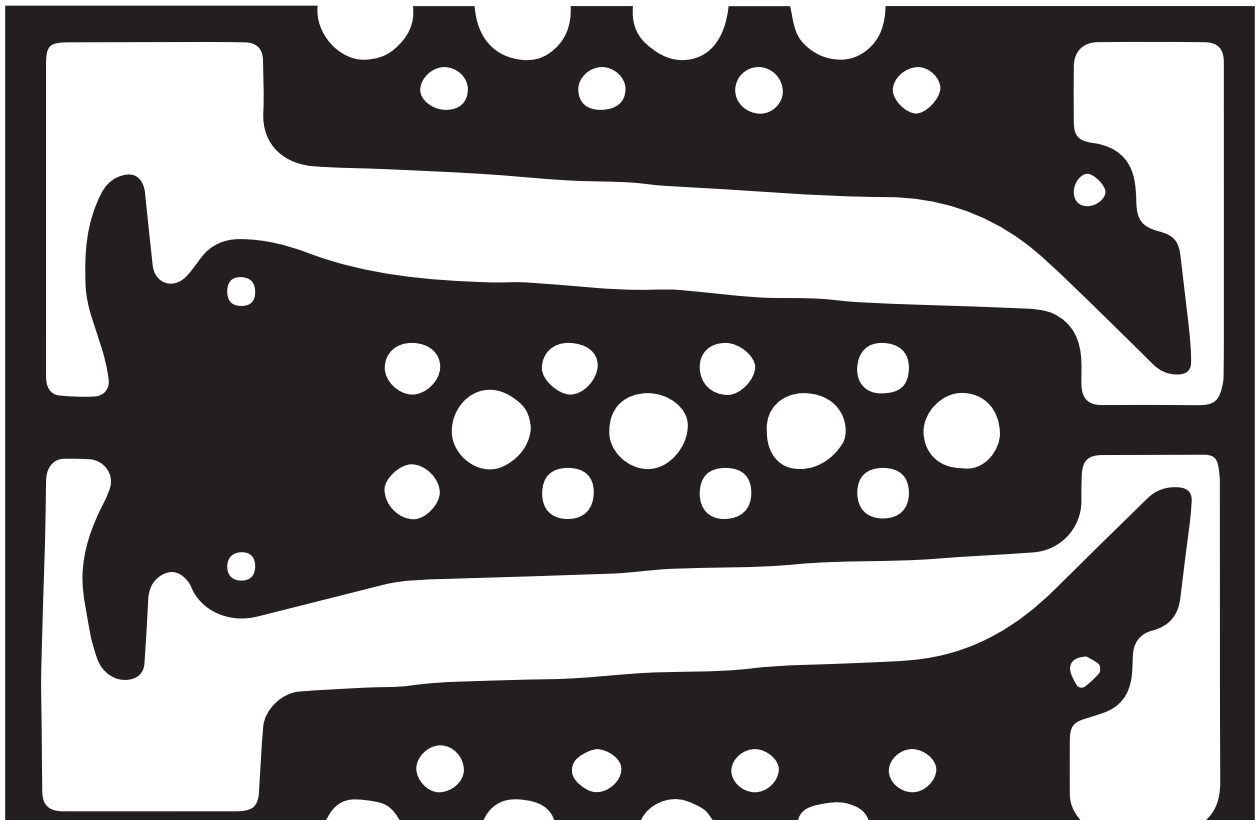

Figure 2.14 The stamped parts of the handle

## 2.3 SCRATCH ANALYSIS

To understand why handles scratch the pot surfaces, literature studies and physical tests were conducted. Experts within the field were then contacted to validate and supplement the findings.

### THEORY

The basic theory behind scratching states that a harder material will scratch a softer material. Furthermore, as the difference in hardness increases, so will the amount of scratching (Britannica Academic, 2017). To measure this tendency, materials can be ranked using Moh's hardness; an ordinal scale from 1 to 10, where harder materials have higher numbers. The scale is nonlinear and based on empirical tests. Both PTFE; the non-stick coating commonly known as Teflon; and aluminium have Moh's hardness ratings around 3 (Huo, Ratulowski and Yang, 2010).

However, when aluminium is exposed to air it instantly forms an outer layer of aluminium oxide with a hardness of 9 (Campbell et al., 1999). As such, the handle is likely to cause significant scratches on the non-stick coating. However, the aluminium oxide provides a crucial benefit as it increases the melting point of aluminium to 2000°C. Without the oxide, aluminium has a melting point of 600°C, while ethanol flames may reach 1800°C and methanol flames 2600°C (Saxena and Williams, 2007; Paul, 1980)

The reason why PTFE is so sensitive towards scratching is the same reason why it has its non-stick properties. PTFE consists of microscopic flakes bond together with very low friction that may become detached from each other. However, the wear resistance of PTFE can be significantly increased by reinforcing the material with graphite, bronze or plastics such as PPS, PI or PEEK, while still providing favourable frictional coefficients (Straffellini, 2015; Stachowiak, 2005).

Reinforcing with bronze will also make the material less likely to overheat, thereby reducing the risk of toxic fumes that otherwise appear at high temperatures (Stachowiak, 2005).

One way to reduce scratching is to use a softer material that will scratch the other surface less. This can however lead to issues with the first material, by making it more susceptible to dents. General design guidelines state that in order to avoid significant scratching, the difference in hardness between two materials in contact should be less than 10% (van Beek, 2009). To measure hardness difference in percent, the total hardness must be used instead of Moh's ordinal scale. In this case, PTFE has a hardness rating of 6 MPa, while Aluminium has a rating of 170 MPa (Dielectric Corporation, 2017).

Hardness is however not the sole contributing factor when it comes to scratching. Even soft materials may cause scratching depending on the microstructure. Rough surfaces and sharp edges are much more prone to scratch, due to pressure being concentrated on smaller areas of the surface. Smooth surfaces will therefore reduce the wear, but could also reduce the coefficient of friction and make sliding between the materials easier (van Beek, 2009).

While theory may hypothesise whether materials will scratch each other or not, the complex nature of the interplaying factors make calculations almost impossible. It is therefore more useful to test the materials

for the various combinations according to Antal Boldizar, Professor in Environmentally Adapted Polymeric Engineering Materials at Chalmers University of Technology. Professor Boldizar also mentions that there is no material soft enough to not scratch PTFE.

## TESTS

To examine the effects of scratching, the handle was observed while used on the pots and frying pan. It was used to lift and hold the pots, with a wide range of grips. The jaws of the handle were smoothed with sandpaper to observe if the amount of scratches changed. From these tests, several causes of scratching were identified.

In most cases, the handle is placed on a pot by allowing the inner jaw to vertically slide down the pot interior. This is a significant cause for scratches located on the inner edge of the pot and it occurs each time the handle is placed on the pot. Another issue occurs when the user closes the handle. Due to the shape of the jaws and rotational movement in the handle, the contact surfaces of the jaw will not reach the pot surface at the same time. This causes pressure points located at the initial touch points, leading to deformation that affects the adhesion of the non-stick coating. Furthermore, the handle will open automatically each time it is released, and the design of the jaws cause both of them to slide vertically along the pot surface and lead to additional scratching. As this occurs each time the handle is let to go, it is a large contributor to scratching.

The two parts of the handle were observed to slide along the axis of the rivet, due to the looseness in the latter. This movement was more frequently observed when the handle was open. However, it may occur even when the handle is attached to a pot, which will cause significant scratching. Furthermore, if the parts is not enough closed, the entire handle may slide along the pot edge as well. Moreover, the handle may shake or quiver unless the jaws have a sufficient grip around the pot edge. This happens frequently if the user does not hold the handle firmly enough, or when lifting duossal pots or older frying pans. This may cause additional pressure points to be formed, leading to deformation and scratching.

Furthermore, the jaws' small contact surfaces have sharp edges and rough finish, caused by the stamping process. This increases the risk of scratching, as the weight of the pots become distributed on even smaller areas. During the test, it was noted that the scratches became less prominent after the edges had been treated with sandpaper. However, as the jaws' contact surfaces are small by design, they still lead to high pressure.

To validate the results of the tests, Håkan Johansson, associate professor at the department for Applied Mechanics at Chalmers University of Technology, was consulted. Johansson confirmed that the aforementioned reasons were the likely causes of scratching. He further discussed that the main reasons for scratching, not taking the surface rough-

ness into account, is likely the inner jaw sliding along the rivet's axis, as well as the jaws sliding along the pots when closing the handle. Furthermore, the rotational movement when closing the handle was mentioned as another main reason for sliding and scratching.

## CONCLUSIONS

To reduce the scratching, the following requirements should be fulfilled:

- The inner jaw should not slide sideways
- The inner jaw should not slide vertically along the inside of the pot when attaching the handle
- The entire contact surfaces of the jaws should reach the pot surface simultaneously when closing the handle
- The jaws should not slide along the pot when the handle opens or closes
- The jaws should have a less rough surface
- The jaws should have less sharp edges
- The jaws should have larger contact surfaces
- The handle should not be possible to slide sideways when holding pots
- The contact surfaces should be in a softer material

## 2.2 TEMPERATURE ANALYSIS

To prevent thermal burns, the temperature of aluminium handles should not exceed 45°C according to studies conducted by NASA (NASA, 2010). Three tests were conducted to investigate the occurrence of high temperatures in the handle. The tests were compared to a simulation of the heat distribution within the handle.

### TEMPERATURE MEASUREMENTS

The tests were performed on an assembled stove. The handle was left hanging on the pot edge for the entire duration of each test. A temperature probe was attached to the handle, allowing the temperature to be measured every 15 seconds to monitor and plot temperature changes. Additionally, a laser probe was used to measure the temperature of the pot and the windscreen.

The first test consisted of boiling a litre of water in the large pot in an ambient temperature of 2°C. The second test used the same configuration of equipment, but was conducted indoors with an ambient temperature of 16.5°C. The third test was conducted indoors with an ambient temperature of 20°C, with the pot switched to an empty and dry frying pan to illustrate an extreme use case.

The indoor tests were performed under fume hoods for safety reasons. The first two tests lasted until the fuel had burned out. Afterwards, the equipment was left to cool down until it reached the starting temperature in the first case, or for 20 minutes in the second case. The last test had to be stopped after 10 minutes as the temperature of the handle exceeded the maximum temperature measurable by the probe.

### Results

With an ambient temperature of 2°C, the maximum temperature of the handle did not exceed 20°C, even though the pot reached high temperatures. The test showed that the handle should not pose any significant risks for burns in these conditions.

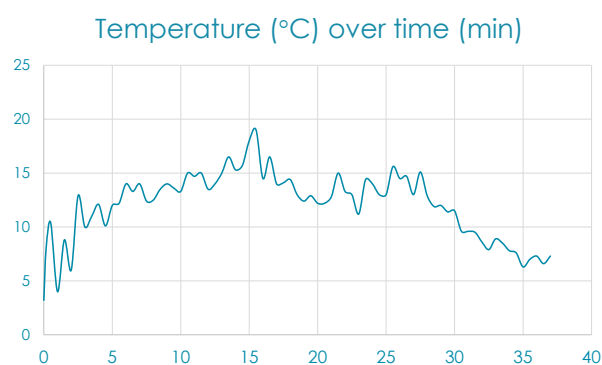

Figure 2.12 Handle temperature boiling at 2°C

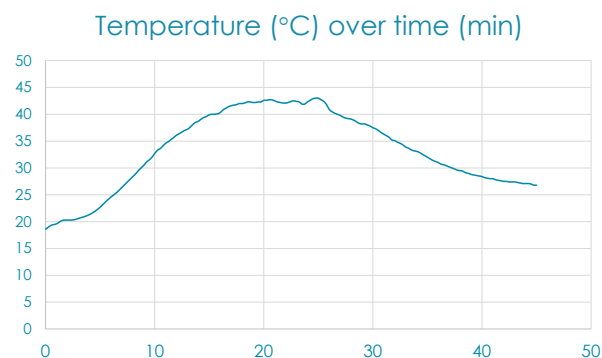

Figure 2.13 Handle temperature boiling at 16.5°C

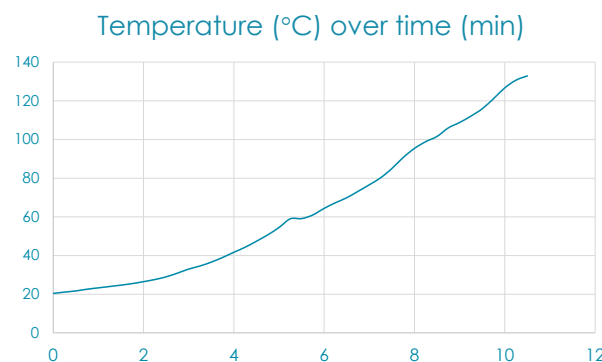

Figure 2.14 Handle temperature frying at 20°C

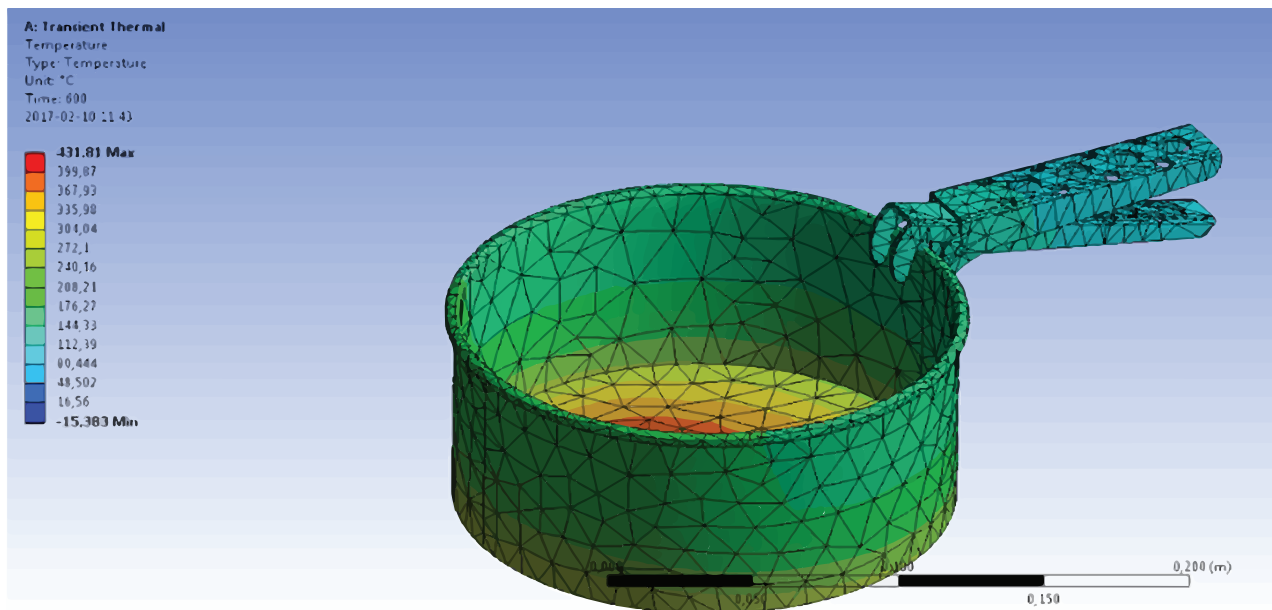

Figure 2.15 Simulation of the handle hanging on an empty pot for 10 minutes

When boiling in an ambient temperature of 16.5°C, the handle reached a maximum 42.7°C. Although this is below the 45°C limit, the temperature could still be experienced as uncomfortable or unsafe by users due to the inherent association between metals and heat in warm environments and cold in normal environments (Ashby, 2011).

However, the handle reached 130°C after 10 minutes on the dry frying pan. This is well above the recommended limits and blisters could occur in less than a second of skin to surface contact (Parsons, 2014). While severe burns are likely to be avoided thanks to the instinctive reflex action, the temperature could still lead to minor burns or damage equipment (Custers, 2015). See Figures 2.12-2.14 for graphs over the temperature spread.

The temperature rise can be approximated with the obtained regression equation  $\text{temp} = 2.11 * \text{time}^{(1.7)} + 20.2$ . This means that 20 minutes of frying would lead to the handle reaching 300°C, if equilibrium is not reached before that. Furthermore, the frying pan reached temperatures higher than 300°C

during the test, likely causing the non-stick coating to release toxic fumes. While frying with an empty and dry frying pan in an almost windless environment is an unlikely scenario, the test still shows that high temperatures can be reached in the handle.

## TEMPERATURE SIMULATIONS

To assure the validity of the temperature tests and to map the heat distribution within the handle, a simulation using CAD models of the stove and the ANSYS software was created. To mimic the frying pan test, the ambient temperature was set to 20°C, the pot was empty and 800 W were said to reach the pot. Furthermore, both handle and pot were assigned an aluminium alloy with the same properties as the alloy used by Trangia.

The simulation showed that the handle would reach about 140°C after 10 minutes, which closely corresponds to the frying pan test. See Figure 2.15. Furthermore, the simulation showed that the temperature would not vary significantly within the handle, unlike the bottom surface of the pot where the temperature varied between 250 °C and 430 °C.

# 03

## MARKET ANALYSIS

This chapter provides an overview and comparison of pan grips for competitor stoves. It also provides an analysis of the Trangia brand and form elements.

# 3.1 COMPETITOR HANDLES

An assortment of different handles were analysed and tested, to evaluate how Trangia performs and to understand which traits users generally prefer.



Figure 3.1 The various handles tested. From left; Trangia, Primus, Optimus, MSR PanHandler, MSR LiteLifter and an older MSR handle.

## METHOD

To test the handles, seven test subjects with varying hand sizes were asked to hold and grade an assortment of existing pot handles. The tested handles were Trangia, Primus, Optimus and three handles from MSR; the LiteLifter, the PanHandler and an older MSR handle. See Figure 3.1. Users were allowed to touch and try all the handles before grading. Furthermore, they were encouraged to try the handles on an empty Trangia pot.

The test participants were asked to rate the handles in terms of comfort, safety and perceived quality. The handles were graded using a scale from 1 to 6, where 1 was considered to be very poor. As the test was executed on a fairly low amount of subjects, the results are not statistically significant. However, the

results still provide insights regarding general trends and preferences.

## RESULTS

All handles use the plier mechanism, in which two parts rotate around a point at the front end and pinch the pot edge between the jaws. The Trangia, the Primus and the MSR handles are made in aluminium, with Primus being matte and the others blank. The Optimus handle is made in an unidentified plastic material. Optimus claim that the plastic is heat-resistant, but testing showed that the material will begin to combust after 12 seconds exposure to the burner flames, causing large deformation and foul smells.

The Primus, Optimus, PotHandler and the old MSR all have larger contact surfaces

towards the pots, likely to reduce scratching. For Primus and the MSR:s, this means another bending step in production. However, larger contact surfaces mean larger areas exposed to warm pots, and potentially more heat transported into the handle. The Primus handle also has small rubber pieces placed on the jaws to increase the grip safety and reduce the scratching.

### Comfort

The Primus and Optimus handles received the highest score on comfort; 4.4, followed by MSR PanHandler. Trangia scored a 2.6, and was therefore the second worst after MSR LiteLifter. See Figure 3.2. The results show that sharp and thin edges towards the skin are less comfortable than broader gripping surfaces. However, as the Optimus and Primus handles received the highest scores, holes and patterns appear to have less of an impact on the perceived comfort than the general shape. Still, round holes as used by Trangia and MSR were stated by some test subjects as more comfortable than elongated holes.

### Safety

Regarding safety, Primus and MSR PanHandler scored highest with an average of 4.7, followed by Trangia with a score of 3.6. See Figure 3.3. The users defined high safety by sufficient grip around the pot edge, as well as trusting the handle to not open unintentionally by itself. Therefore, users need to feel that they have control over both the upper and the lower parts of the handle.

Some users preferred handles that were not completely closed when gripping, as this made them feel that they could grip the handle harder if necessary. For these users, Trangia received a lower score. Other users preferred handles to be fully closed when holding, as this provides them with clear feedback that they have a safe grip.

### Quality

In terms of quality, Trangia scored highest with 4.3 followed by the MSR PanHandler with a score of 4. See Figure 3.4. The users judged the quality of the handles by their perceived robustness, the

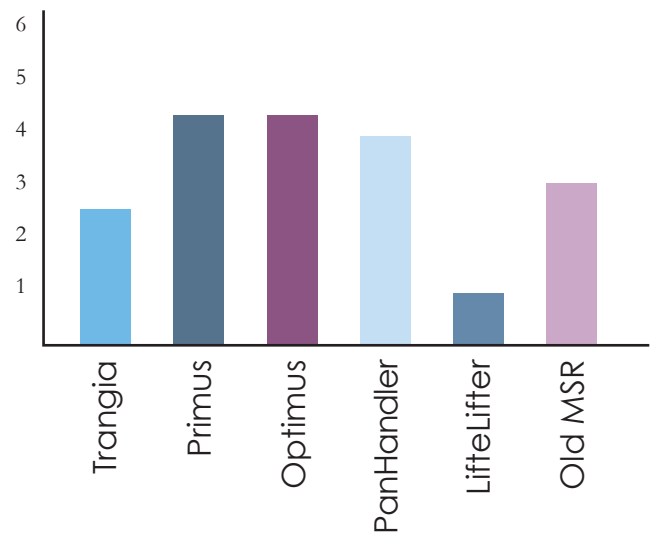

Figure 3.2 The average handle comfort ratings

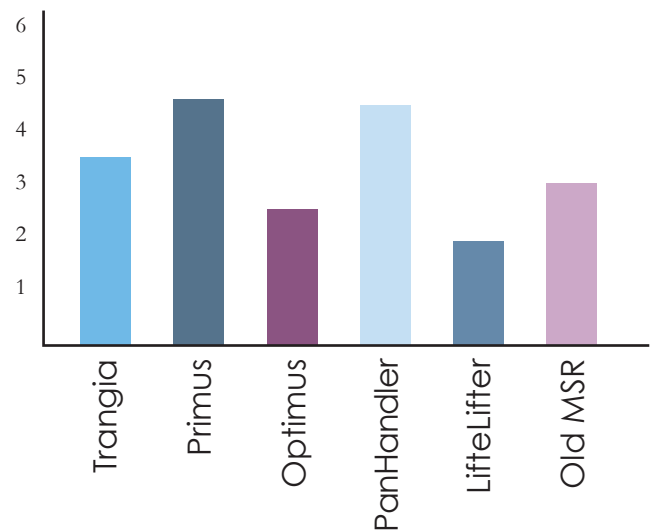

Figure 3.3 The average handle safety ratings

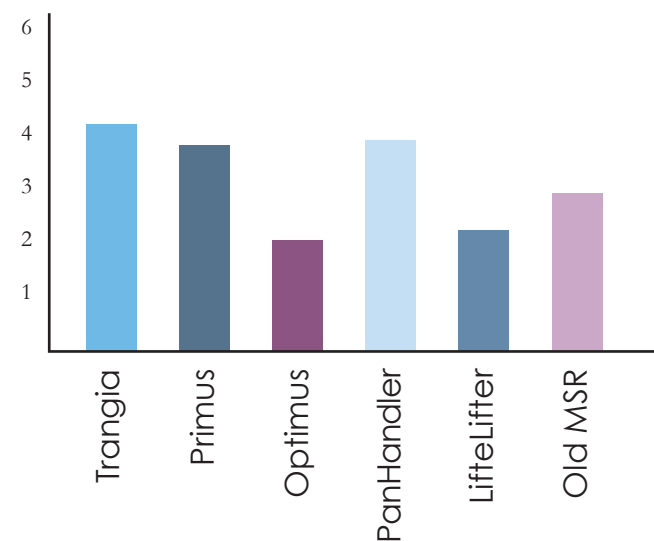

Figure 3.4 The average handle quality ratings

sounds of the handle opening and closing, the looseness of the rivets as well as the flexion in the gripping surfaces when lifting pots.

As the Optimus plastic handle flexed remarkably, it can be deduced that flexion is a particularly significant factor. Users commented that flexion made them perceive it as unsafe, cheap and with a shorter lifespan than the aluminium handles. It was also noted that surface treatments and finishes have an impact on the perceived quality. Some users found blank aluminium to be more qualitative while others preferred a matte or brushed finish.

In general, users want robust handles that will not easily break. For this reason, many users mentioned that they would use the Trangia handle, despite the low score in comfort. Interestingly, a light handle was often initially regarded as unsafe and less robust. However, the users themselves discussed that a

low weight could be advantageous given the context of these products. Finally, some users want an aesthetically pleasing handle with a streamlined shape without protruding parts.

### Trangia

In general, the Trangia handle is appreciated for the high quality and its ability to easily open and close. As previously mentioned, there was a difference between those who wanted the lower part to touch the upper when the handle is closed, and those who want to have space left between the parts to be able to grip it harder. The sense of safety is diminished due to the probability of dropping pots unless the user has a sufficient grip around the lower part. It is found that the main reason for discomfort is the sharp edges on the underside and close distance between the gripping surfaces. See Figure 3.4 for image of the handle.



Figure 3.4 The Trangia handle

## Primus

The Primus handle was seen as providing a satisfying grip due to its height and width. It was however noted that the shape of the holes were less comfortable than the MSR PanHandler or Trangia's holes. It was seen as safe, but the fact that the jaw does not touch the pot edges when holding made it feel less stable. See Figure 3.5 for image.

The low weight made some of the users question the quality of the handle. However, as previously mentioned some users commented that in the use context, lower weight could be considered as a positive trait. The small rubber parts on the jaws were liked, but questioned from a quality point of view. Users questioned if the rubber would burn or fall off. Moreover, the fact that the handle tends to close askew was noted and disliked.



Figure 3.5 The Primus handle

## Optimus Terra

The fact that the handle is made in a plastic material made many users sceptic toward both the overall quality and the handle's ability to withstand heat. This impression was enhanced by the flexion experienced when gripping the pot, and users found the handle as less secure than its metal counterparts. While the distinctive finger grips rarely fit the users' hands, they were still regarded quite comfortable. The smooth top surface was also especially liked for comfort reasons. See Figure 3.6 for image.



Figure 3.6 The Optimus Terra handle

### MSR PanHandler

The grip was generally regarded as positive, and the handle was seen as safe. The comfort when gripping was high, due to the smoothed holes and surfaces. Some users liked that the PanHandler required less force than Primus to close. However, a major drawback was that the handle is sometimes dull and hard to open. See Figure 3.7 for image.

### MSR LightLifter

The LiteLifter was overwhelmingly disliked, with the only positive aspects being the small size and the red coating. It was considered to be very uncomfortable to use, and the poor hand grip affected the safety. Users believed that they were more likely to drop pots because of the grip. See Figure 3.8 for image.

### Old MSR

The reviews of the old MSR were mixed. Some found it more comfortable than they expected, while others found it uncomfortable. The width of the handle was generally seen as too narrow for a good hand grip. Moreover, the grip of the pots were insufficient, and the handle was found difficult to open. Indeed, the handle would sometimes get stuck on the pots, resulting in users having to pry it open. Moreover, the design was compared to a potato peeler. See Figure 3.9 for image.

## CONCLUSION

The tests made it clear that it is very important to make a handle that the users feel they can trust. Else, they will not bring it with them no matter how comfortable or aesthetically pleasing it is. This is especially important to consider for a handle made out of a plastic material, as plastics tend to bring negative associations regarding quality and robustness. A plastic handle has to feel robust and safe to use, and must exhibit very good properties regarding flame resistance, heat distribution and toughness. It is important that users can grip both parts of the handle separately for comfort and safety. Sharp edges are overwhelmingly disliked and reduce comfort to a very high extent. Users want to be able to vary their grips on the handle, and still obtain good comfort. Furthermore, it was found that users value simple designs over more complicated constructs.



Figure 3.7 The MSR PanHandler handle



Figure 3.8 The MSR LightLifter handle



Figure 3.9 The MSR PanHandler handle

## 3.2 BRAND ANALYSIS

The Trangia brand is strongly associated with a traditional outdoors and hiking lifestyle. As a family owned company, the family history is in many ways synonymous with the company history. This is evidenced by their brand story discussing the founder John E. Johnsson and his sons' and grandsons' achievements. The traditional values and emphasis on the family history enhances the company's segmentation towards families, traditional hikers and outdoors enthusiasts.

Furthermore, the name Trangia is derived from Trång, the home village of Trångsviken, t, and Al as in aluminium. This shows that both the physical location of the company and the aluminium material are essential to the brand. Lastly, while their competitors have been more and more focused on fuel sources such as gas, Trangia still promote the spirit burner. In fact, the spirit burner could be seen as an important part of the Trangia brand and is often the fuel source that consumers associate with the Trangia stoves.



# 04

## USER STUDIES

To be able develop a successful new design, it is necessary to understand the use situation of today and the associated problems (Ulrich and Eppinger, 2011). To obtain this knowledge, numerous users were interviewed and observed, and the results are summarised below.

# 4.1 USER STUDY METHOD

The user studies consisted of an online questionnaire with 394 respondents, 21 telephone interviews, 46 mail interviews and 15 user tests with 35 participants in total. The users were of different genders, ages and use the stove in various situations. All users were regular Trangia users, recruited based on this fact.

While most of the users use their stoves while hiking, camping or simply while spending time enjoying nature, examples of how other users may use their stoves includes using it indoors as a backup for power outages or for cooking food when camping at festivals.

The questionnaire was shared through relevant forums and social media to obtain mass input of data. It consisted of general questions regarding the Trangia stoves, with the aim of mapping the users' opinions of the handle, the overall functionality and frequency of use. The survey and corresponding statistics can be found in Appendix 1.

Interviews were conducted to gain a deeper understanding of the users' thoughts and opinions regarding the stoves. These were done either through telephone calls or through mail conversations. An interview procedure, found in Appendix 2, was used during the telephone and mail interviews as well as during product tests.

For the mail conversations, users were contacted through online forums and social media and asked to share their thoughts and opinions. The users were then asked follow-up questions based on the interview procedure. For the product tests, the interview was supplemented with a scenario where the users were asked to:

1. Assemble a Trangia 25-4
2. Fill and ignite the spirit burner
3. Boil a small amount of water

4. Swap the pot for the frying pan
5. Extinguish the burner
6. Pack the stove

The users were allowed to choose if they wanted to extinguish the burner or wait until it had burned out by itself. Their ability to solve the tasks were observed and noted. The users were encouraged to share their thoughts and explain their actions during the test. Afterwards, they were to rate how well they performed their tasks and if there were any steps that they struggled with. The tests were documented through audio and video recordings.

The interviews were transcribed, and the video footage from the tests were analysed to identify how the users hold and interact with the handle and which tasks they use the handle to perform. The collected data was then read through, with important comments and aspect written down on sticky notes along with the frequency of the specific comments.

Each data source was summarized individually and then merged. Using the KJ-method, the data was analysed and sorted according to problems, themes and use context. The data was then further analysed to identify the underlying needs and requirements.

## 4.2 USER STUDY RESULTS

The results in this section mainly concern the handle and the necessary context. Other findings in this chapter are written from the perspective of the handle. The user study however found immense amounts of information regarding other parts of the stove as well.

A complete summary of the findings can be found in Appendix 3.

### GENERAL REMARKS

The respondents of the questionnaire were generally pleased with their stoves. When asked to rate their satisfaction, the average rating was 4.8 out of 6. Trangia products are seen as durable and reliable with a very long life span. A new handle must therefore be equally durable and inspire a high degree of trust in the product.

The stove is considered to be trustworthy in severe weather conditions, and the versatility regarding fuels, use situations and storage possibilities are mentioned as great advantages.

Users are pleased with the possibilities to repair and bend damaged parts, as well as the possibility to obtain spare parts from Trangia. These findings mean that the new handle should be designed to work in poor weather conditions and a wide range of use situations. It should also be able to withstand dents and rough use.

However, as Trangia lack social media presence and do not run marketing campaigns aimed at consumers, they are seen as almost invisible by the participating users. While the brand and traditional stoves are well known in Sweden; accessories and additional products are often unknown. As a result, users often wish for new specific products that the company already offer, such as the Multi-disc. It is therefore important that Trangia will communicate and spread awareness of a new handle, or else risk limiting potential sales.

### USE CONTEXT AND SETUP

Different users prioritise different aspects of their equipment. For long distance hikers, low weight is a highly desirable trait, especially for those hiking alone. For kayakers, volume is much more relevant than weight while casual campers tend to prioritise comfort and usability. However, the main priority for all user categories is the functionality of the stove. Trangia stoves are often specifically chosen because of their reliability and versatility in use. Furthermore, the Trangia stoves are often chosen because of their ability to facilitate normal cooking instead of simply boiling water for freeze dried provisions.

While some users have had issues with annoying, rattling stoves during transport, most users find that the different parts of the stove fit well together while packed. The compact packing solutions and the possibility to store smaller cooking items and utensils within the stove is much appreciated. Items that were frequently stored in the stoves were Multi-discs, cleaning and cooking utensils, igniters, spices, can openers, cutting boards, plastic bowls or additional pot handles. Furthermore, it was discovered that many users have a pre-packed setup of Trangia pots, pans and cooking items that they keep ready to use, with few users changing or modifying their setup.

These findings show the importance of designing a handle that is light and nimble

enough to be easily stored with burners and other items in the stove. It would be advantageous if the weight of the handle could be reduced somewhat, but this should not be achieved at the expense of the functionality. The new handle should preferably rattle less than the current one, and shall fit into the kettles.

## CLEANING

As previously mentioned, it was found that Trangia is often associated with conventional cooking. It is therefore very important to facilitate the cleaning process and avoid issues such as food poisoning from contaminated cookware. Users need to take soap and washing utensils with them, and either bring water or find a suitable source. As a result, many users develop different tricks to avoid unnecessary cleaning, such as by eating directly out of the pots. This however means that they tend to scratch the pot surfaces with metal cutlery. Furthermore, the users tend to hold the pot with the handle while eating. This means that they will hold the handle continuously for several minutes, something that increases the demand of a comfortable grip.

During daytime excursions, users often give their cookware a quick rinse followed by proper cleaning at home. The handle is somewhat hard to clean due to the holes and hidden surfaces, leading some users to put them in their dishwashers. While effective, it was found that this may lead to dull surfaces that can cause the handles to become sluggish. When developing a new handle, it is therefore important to make sure that it can be easily cleaned. Preferably outdoors, or otherwise by the aid of a dishwasher.

## THE BURNER

Regardless of burner or fuel source, flames will spread around the outer pot surfaces. This means that the handle will be exposed to open flames. While the contact between

flame and handle is usually contained to a split second, there are exceptions. Using the spirit burner with the winter attachment will cause high flames until the attachment burns out. The severeness of these flames can cause both knobs and handles of the kettle to melt, as evidenced several times during the tests.

Users often use the handle to adjust the simmer ring on the spirit burner. This is however very hard to do, as the entire ring tends to rotate on its own. The handle will therefore get in close contact with the burner flames for several seconds. A new handle must withstand the heat from the burners without deforming or igniting. Furthermore, the handle should not reach unsafe temperatures while performing tasks such as adjusting the simmer ring.

## WINDSCREEN AND POT HOLDERS

The handle is often used to rotate and move the windscreen, as well as to fold the pot holders up or down. While the windscreen might be hot, folding the pot holder will expose the handle directly to the flames. Some users also found the need to hold and stabilise the windscreen with a second handle when adjusting the pot holders.

Furthermore, the pot holders raise the frying pan too high above the edge of the windscreen for efficient cooking. Cool air and winds flow between the pan and the windscreen, and severely disturb the frying process. Some users solve this issue by ignoring the pot holders. They will instead use the handle to hold the frying pan in place just above the edge of the windscreen. This involves a prolonged use of the handle and increases the need for grip comfort and a comfortable temperature of the gripping surfaces.

## THE POTS AND PANS

The pots and pans are the main items to be lifted by the handle. While this usually is an easy process, the pots are sometimes placed in open

fire to keep them warm. At that point, they become hard to grab with the handle without risking burns. Furthermore, many users ignore the instructions and place the frying pan upside down as a lid. This makes it hard to reach and grab the pan edge. Some users will lose their patience and instead use their hands to remove the potentially hot pan.

62% of the survey respondents own a kettle. Some regard it as essential, but others see it as a heavy and optional object. The kettle is more frequently used over fire than the pots, and the built-in handle is appreciated for the possible suspension over the campfire. The kettle is very rarely, if ever, used with the pot handle. However, the handle needs to fit inside the kettle during storage.

Several users have had issues with the non-stick coating. When asked to rate the non-stick's perceived resistance against scratching, the result was an average of 2.8 out of 6. Furthermore, users described the current non-stick coating as less durable than older Trangia non-stick pots as well as those made by competitors. It should be noted that while Trangia provide a protective sheet for the non-stick coating, only a third of the surveyed users kept the protector. Instead, some use the Multi-disc or other items such as dish cloths or cutting boards to protect the pan surface. However, many others simply do not use any protection at all. In terms of material, many users requested pots in other materials, and a common desire is to bring back the duossal pots for their high durability.

To increase the overall sense of satisfaction with the Trangia stoves and improve the perceived quality, the new handle must have a reduced tendency to scratch the non-stick surfaces. To solve this issue, the entire use situation needs to be analysed and included in the solution. This means that in addition to the active use and gripping of the pots, the handle should avoid causing scratches while stored in a packed stove during transportation. However, it is important

to remember that duossal pots and older frying pans have a different edge than the aluminium pots due to manufacturing constraints. There are a significant amount of users who still use their old duossal pots and others who want to change to duossal if it becomes available again. The handle must therefore be able to safely use on the duossal pots as well.

## PLASTIC PROTECTOR AND BAG

According to the survey, only a third of the users keep the non-stick protection sheet. Many are however unaware that it should be saved. This is often attributed to the abundant recycling symbols, which are interpreted as an indicator that it should be disposed with the rest of the packaging. To protect the frying pan, some users use multi-discs, sponge cloths or paper instead, but there is a significant number of users without any protection. This highly increases the risk of causing additional damage to the non-stick. It would therefore be beneficial if the handle could be stored in the stove without moving or bouncing during transportation.

While the cover bag and locking strap are designed for storing, locking and carrying the stove, they are also used for storing and securing items when the stove is used. Users with the cover bag often place the handle and other small cooking items within the bag. This serves to keep track of the items as well as to keep them clean.

## THE HANDLE

As the handle is the main object of study in this thesis, it is thoroughly described from different viewpoints below.

### General

The users have a rather positive experience of the handle, with questionnaire respondents rating it on average a 4.8 on a scale from 1 to 6. The comfort when gripping is rated as fairly good, with an average rating of 4.2. It is regarded easy to use and understand the

handle, although children might find problems with it. Their smaller hands serve to make gripping somewhat harder, and lower motor control makes them more likely to get pinched by the handle. Otherwise, users found it hard to maintain the same grip while opening and closing the handle, and some have trouble manoeuvring the handle into place without unintentionally closing it.

Most users will remove the handle from the pots when cooking. Indeed, only 16% respond that they leave the handles hanging. Users explain that it is common for novices to leave it hanging once, but the temperature increase will quickly teach the users. However, having to remove the handle is often not in accordance with the users' desires. A large share would indeed like to leave the handle in place, if they could do so without risking thermal burns.

Apart from grabbing pots and pans, the vast majority of the respondents use the handle to fold the pot holders as well as to adjust or grab the upper windscreen. It is also commonly used to adjust the simmer ring of the spirit burner. However, this adjustment is hard to do as it is difficult to get a sufficient grip around the lids. The handle is also used to hold the pots when eating out of them, as well as to grab other cookware, bowls and mugs. Some users have found more creative uses for their handles such as stirring food or breaking branches. The opinions are rather mixed when it comes to the aesthetics of the handle. Some like it a lot, while others find it quite unappealing. However, most users do not prioritise the aesthetic properties for this kind of product.

### Harm caused by the handle

It is widely noted that the handles scratch and deform the pots. Although this mainly affects non-stick coating, other materials are harmed as well. Scratching and deformation occur both when the handle is actively used, as well

as when being packed into the kitchen and tumbling around.

The handle is also known to harm users in various ways. As previously mentioned, users may forget to remove the handle from the pot and get burned when they grab the handle again. Many users have also pinched their hands when closing the handle, and this sometimes leads to bloodshed. The handle is also known to drop pots, which will cause hot water to spill out. If somebody is hit by the fallout, they may suffer from severe burns. Such cases often occur when attempting to hand over a pot to another user, or when a shaking pot scares the user and makes them open their hands as a reflex.

### Physical ergonomics

Despite receiving a fairly high comfort rating of 4.2 in the questionnaire, many users complain about the comfort. Those who only hold the handle for shorter durations tend to care less about the comfort, but those who hold it longer, when eating from pots or holding the frying pan continuously when frying, are much more concerned about having a comfortable grip.

The sharp edges and lack of a sufficient lower gripping surface were found to be the main issues causing discomfort. This can affect the users' trust in the handle, with some users being unsure of their grip around the lower part of the handle. Indeed, many users distrust the handle's ability to maintain its grip on the pots overall. This distrust combined with the ease of the which handle opens by itself leads users into tighter grips, and thereby more discomfort from the sharp edges.

Even though some users found the size of the handle too small, the vast majority of the respondents found the size to be comfortable. The issues with the handle's size and weight are almost exclusively tied to storage space and packing ability. In those instances,

some users find the handle to be too heavy. Some have even gone so far as to drill holes and modify the handle to save weight. However, weight is not a main concern for most users.

## Use

The handle is regarded to provide an adequate grip around the pots. Some difficulties may however arise when gripping pots with curved edges; such as the duossal pots. The handle may then slide sideways, even when being held closed. This problem is especially apparent for older handles with looser rivets, causing the lower part to slide along the rivet's axis. Older handles are also more prone to get jammed shut, and may have become bent after prolonged use.

A common problem is that handles tend to get temporarily lost. As users detach the handle from the pot, they often leave it somewhere else and forget where they put it. If multiple users share the handle, the risk of it getting lost increases. It is not uncommon that users bring two handles in case one disappears. Others paint it in bright colours to be able to find it quickly. Some users also want to avoid placing the handle on the dirty ground, and therefore search for alternative placements. It may be put in the cover bag, and others even tie it to their stoves. However, the problems with placement do not only apply to campsites. It is noted that the handle lacks a designated place in the stove, and can be hard either to fit in a kettle or place above it. As mentioned before, the handle may bounce around in the stove, causing noise and damage to the pot surfaces.

The properties of aluminium contribute to the handle getting very cold in the winter. Indeed, it may even freeze shut. The handle is also considered somewhat difficult to use with gloves. Gloves get stuck in the handle, and they impair the fine motor skill required to manoeuvre the handle. To prevent the

issues caused by aluminium's thermal properties, some users have suggested that the handle should be made from another material.

The handle is often experienced as rather hard to clean after cooking. Some users solve this by cleaning the handle in their dishwasher, although this leads to the handle getting dull, sluggish or jammed.

## Other comments

To counteract some of the problems experienced with the handle, many users are interested in a locking mechanism to secure the handle on the pots. However, they want to make sure that such a lock is easy to open, and that it would not impair the overall functionality or durability of the handle. Others instead ask for self-opening handles, so that they may avoid getting the handle stuck.

There are quite a few users who want other integrated functions in the handle, such as can or beer openers, cleaning needles for burners or spatulas. There are even those advocating turning the handle into a multitool. A common discussion is whether attached or detached handles are optimal. Most users prefer detachable handles for easier storage, simple replacement, heat benefits and not getting in the users' way.

The common Trangia handle is generally seen as far superior to the Trangia mini handle, that some users bought believing it to be a new version of the original handle. Overall, most users find the handle to be working well, but some see it as the least good thing with Trangia. Despite this, it is common to use Trangia handles for stoves and pots from competing brands.

## 4.3 SWOT ANALYSIS

A SWOT Analysis was conducted based on the findings on the user study. It lists Strengths, Weaknesses, Opportunities and Threats relating to the handle.

### STRENGTHS

Trangia is generally perceived as a very strong brand in the Nordic countries. The company and the stove are well known and recognized. Several interviewees even mention how they consider Trangia as a word to be interchangeable with the term camping stove. Many users expressed their strong affection for the brand, indicating a strong loyalty between user and company.

Furthermore, the quality of the products in terms of reliability and durability is regarded as very high. Users praise the indestructibility of the Trangia stove, and some users even mention that it is “almost too good for the company”. Trangia stoves have a reputation of getting the job done despite poor weather conditions or other extrinsic factors. This is due to a combination of durable materials, few unnecessary parts that can break and the construction of the windscreen.

These positive aspects are present in the current handle as well. It is simple, traditional and very robust. As mentioned above, many users will even use the Trangia handle with competitors’ pots. A high degree of trust is often put in the handle and its ability to lift pots safely.

### WEAKNESSES

As discovered by Trangia themselves, the tendency to scratch and dent the pots is an important problem with the handle that must be solved. Many users also report that they have had issues with handles becoming too hot, dropping the pots that they were carrying, pinching their hands when closing the handle or harming them by the sharp edges. Overall, the handle is not seen as particularly comfortable to hold, as shown in the competitor analysis.

One of the most common overall complaints against Trangia is that the products are larger and heavier than their competitors. Some users consider the handle to be heavier than it needs to be and may even modify it by drilling holes to reduce weight. Ultra-light weight packing is indeed a current trend within the outdoors community, and it should be considered when moving forward with the product development process.

Finally, there are issues relating to the storage of the handles. Users often complain that the handle can be hard to keep track of, especially if there are multiple people using the stove. The handle can be hard to see when it is laying on the ground, and some users complain that they do not know where to place the handle when it is not attached to a pot. Additionally, the handle may bounce around during storage and thereby cause an annoying, rattling sound in addition to denting the pots.

## OPPORTUNITIES

There are large opportunities for Trangia in developing a new handle using modern technology and materials. This could lead to better technical properties, such as weight or size, and increased functionality of the product. Furthermore, all competitor handles rely on a plier mechanism and all but two are made from untreated or painted aluminium. By investigating alternatives to the plier mechanism, finding new material or adding surface treatments, the handle should be able to stand out more from the competitors.

## THREATS

Since Trangia have relied so heavily on their traditional designs, there is a risk of them being experienced as dated compared to their competitors. Many competitors seem to move away from detachable handles and this could affect the consumers' attitudes towards the Trangia stoves.

There is an issue of using aluminium in cookware. Legislative instances and some of the users have concerns regarding the levels of aluminium released into the food, and its effect on the general health of the users. This affects pots more than handles, but it is still important to consider as the handles may be in contact with food.

# 4.4 PERSONAS

The users encountered through the studies can broadly be divided into five categories, with varying demands and use situations. These are summarised as five personas with the aim of describing the user clientele.

## THE FAMILY

The Family enjoy spending time together in the great outdoors. They try to go on shorter, 4-5 hour long excursions at least once every six weeks. Each summer they will spend a weekend or two camping. With three young children, the cooking needs to be effortless and quick. Indeed, the campsite is always lively with the children playing and running around.

As the children grow older, they gradually take a more active role in the cooking. Despite the children's best intentions, small objects such as the handle might get misplaced when attention is drawn away to something more exciting. All in all, the Family use Trangia stoves for their stability and safety, as well as the possibility to boil and fry large amounts of food.

- 2 adults, 3 children
- Busy camping site with much activity
- Quick and effortless cooking is a must
- Safety is paramount
- Objects are sometimes misplaced or mishandled

## THE LONE WOLF

Spending time alone could prove a necessary relief in a busy world. The Lone Wolf may devote most of their time to company with others, but every now and again they disappear into the woods for a day or two. The Wolf travels light and only brings essential equipment. They always keep a backpack with basic camping gear ready, making it possible to leave at short notice.

The Wolf most often eats straight out of the pots to cut down on chores. They always takes pride in being able to survive on their own merits for days at a time. Were an accident to happen, the Wolf is determined to solve the issue alone. Since the Wolf rarely brings a phone, there are limited options for calling for aid if something goes amiss. It is therefore important that the Wolf is able to fully trust the brought equipment.

- 1 adult
- Quiet and calm camping site
- Eats out of the pots
- Needs to trust the equipment
- Spends time outdoors to get away and relax

## THE EXPLORER

The Explorer is driven by an urge for new experiences. No matter if it regards navigating through dense forests, mountain biking across a tundra or climbing the highest mountains; the explorer is always willing to try it out. This makes the Explorer go on fewer but more ambitious and longer expeditions than other users. Planning and preparing comes out as a major part of the experience and proves to be critical for the success of the trip. The Explorer rarely goes alone, and instead travels with a small group of likeminded friends.

As the expeditions tend to be physically demanding, weight is a major issue. Prioritising between functionality, weight and robustness can be hard. Every gram counts, and fuel efficiency is an important part of saving weight.

This is a main reason for using Trangia stoves, as the windscreen proves to reduce the fuel consumption more than the increased weight. The harsh environments sometimes encountered are also a main reason for a reliable stove. However, the Explorer is always looking for new interesting equipment that can withstand their high demands.

- 3 adults
- Expeditions can last for many weeks on end
- Very high demands in terms of weight and robustness
- Spends much time looking for and researching new equipment
- Fuel efficiency is very important

## THE KAYAKER

On a sunny day, the Kayaker can be found exploring islets and bays. The Kayaker normally travels in pairs, but is sometimes joined by friends. For the Kayaker, weight is not really an issue. Instead, the equipment needs to fit inside the kayak's storage compartment and therefore the dimensions are more critical.

The wind is often harsh, increasing the demand for a sufficient windscreen. Driftwood, stones and various debris is often used to stabilize and cover the stove. Moreover, when the kayaker travels by the coastline, the salty environment takes its toll on the stoves and may cause equipment to corrode.

- 2 adults
- The dimensions of the stove are critical
- The stove may be exposed to salt water
- Increased demands for a sturdy and wind-proof windscreen
- Weight is not an issue

## THE CAMPER

Hiking can be fun, but some people want to relax and travel in full comfort. The Camper prefers to take the car to the camping site, and values comfort over weight efficiency. Once the equipment has been set up, the Camper prefers to lean back with a beer in the hand and enjoy the company of family and friends.

Quality meals are a necessity in order to enjoy the holiday. Therefore, the Camper is prepared to bring any equipment that can facilitate their cooking ambitions. They often tends to pack their Trangia stove full with accessories, and it is not uncommon to bring more than one stove. As an important part of the Camper's lifestyle, the stove should not only provide a function but also express the associated identity and values that the Camper wants.

- 2+ adults
- Weight is not an issue
- Comfort and extra functionality is important
- The product should have a strong visual identity
- The stove should allow the user to cook for different amounts of people



# 05

## MATERIAL STUDIES

Since the current aluminium handle can reach unsafe temperatures during use and the hard oxide surface will scratch the pots, alternative materials were explored. This chapter contains analysis and tests of potential materials.

# 5.1 METHOD

The aim of this Chapter was to find new materials that:

- Can withstand the heat generated by the burner
- Can be used in contact with food
- Will not burn
- Can sustain flames for prolonged time without deforming
- Has a low thermal conductivity
- Will decrease scratching and deformation on the pot surfaces
- Can withstand dents and reasonably rough handling
- Is reasonably priced
- Will not increase the weight of the handle

The Cambridge Engineering Selector, CES, was used together with material data sheets and news articles to find suitable materials. CES is a database containing virtually all commercially available materials, and comes with immense sorting and ranking possibilities. It is used to aid engineers by attributing limits and relationships between properties in a way known as the Ashby Method (Ashby, 2011). Potential materials were identified, after which simulations were done to map the heat distribution. Material samples were later obtained, and used to test burnability, deformation, impact resistance and scratching.

# 5.2 POTENTIAL MATERIALS

By investigating materials in CES with a high maximum use temperature, low thermal conductivity, high heat capacity, low abrasion, high fracture toughness, high modulus and high yield strength as well as low price; with differing relationships; a number of materials were found. Additional materials were then identified using fact sheets and press releases.

Few plastic materials can withstand high temperatures, and even fewer can withstand flames without burning. Despite this, there are a few alternatives that can be considered, even though the most heat-resistant plastics are excluded due to high price and non-compliance with food regulations. It is important to note that virtually every polymeric material have low stiffness, strength and fracture toughness. This can however be somewhat mitigated by reinforcing the material with glass fibre. While this is a commonly used and relatively cheap solution, glass fibre reinforcement causes other issues by complicating the recycling process and increasing the material's abrasiveness.

The most promising materials are summarised below. Information regarding excluded materials and a summarising table can be found in Appendix 4.

## PPS (POLYPHENYLENE SULFIDE)

PPS is a polymeric material that combines a high melting point, low degree of thermal expansion, fairly low weight and high dimensional stability with a relatively low price. PPS stands at 40 SEK/kg compared to 20 SEK/kg for aluminium. It can be used between -45 and 280°C.

The material is inherently flame retardant and therefore eliminates the need for harmful flame retardant additives (Solvay, 2017). Due to the thermal properties and dimensional stability, PPS is currently used by the automotive industry in engine parts, and has been used for ordinary frying pan handles (Platt, 2003).

Pure PPS is somewhat brittle, but glass-fibre reinforced PPS has a higher fracture toughness (Miltonplastics, 2017). It is possible to injection mould PPS, although somewhat more difficult than for other plastics due to the high melting point. While injection moulded PPS allows the manufacture of products with very high tolerances (Elders

and Ullmann, 2016). Additionally, the material has a tendency to ring like metal when hit, a property that may increase the perceived quality of a product in PPS.

Carbon-fibre reinforced PPS has a very low coefficient of friction and would scratch PTFE less, however it is also prone to burn (British Plastics Federation, 2017). When exposed to very high temperatures, reinforced PPS may melt but it will not drip. The 65% glass/mineral filled PPS should not be able to melt, but is instead very brittle (Solvay, 2017).

Should PPS burn, it will release fumes such as carbon dioxide, water vapour and sulphur oxides. Other compounds may be released in certain conditions as well (Solvay, 2017). The fumes will smell bad, and may cause irritation in the respiratory tract. Overexposure may also cause headaches. However, the fumes are unlikely to be dangerous (PPS Resin: Material Safety Data Sheet, 2009).

## PEEK (POLYETHERETHER KETONE)

PEEK is a high performance plastic with very attractive properties. Unfortunately it also has a very high price of around 600 SEK/kg. Glass-fibre reinforced PEEK can be used at temperatures between -60°C and 270°C. It has a very low heat transfer coefficient, is very dimensionally stable and maintains its stiffness even at high temperatures.

PEEK is stronger than most polymers, but has also got a lower stiffness (Cambridge Engineering Selector, 2017). It can be used in contact with food, and is often used to replace metals. PEEK is very inert, inherently flame retardant and will not emit significant amounts of dangerous gases if burned (Foster, 2017).

## ALUMINIUM

Aluminium has good mechanical properties for a handle, but the main disadvantages are the heat conductivity, hardness and high-

er weight compared to plastics. As shown during the product analysis, the temperature of the handle may increase significantly when left hanging on a pot, and the hardness of the aluminium oxide leads to more scratches and dents. It should be noted that hard-anodized aluminium transfer less heat than regular material, and the darker less shiny surface would affect the experience of heat as well. However, hard-anodized aluminium is not only expensive but also harder and could therefore lead to more scratches (Ahlin, 2017; Coastline Metal Finishing, 2017).

Coating aluminium in a dark or matte colour could ease some of the heat issues. Coloured aluminium allows more heat to radiate off, as the shiny reflective surface of the untreated material prevents heat from being emitted (Physics world, 2017). As stated in “What does color have to do with cooling?” (2017), painting the material would lead to the product cooling down faster in a warm environment and absorbing more heat in a cold environment. The darker the colour of aluminium, the more heat will be emitted or absorbed, and the cooling process will go faster. This is asserted by associate professor Fredrik Normann at the department of Energy and Environment, Chalmers University of Technology. However, the exact nuance contributes much less than the fact that it is painted at all.

## STAINLESS STEEL

Stainless steel has better mechanical properties than Aluminium, but is also heavier. As stainless steel has a lower thermal conductivity than Aluminium, it would make the handle stay cooler (Cambridge Engineering Selector, 2017). The chromium oxide forming on stainless steel surfaces is also softer than aluminium oxide, and would reduce of the scratching.

However, since stainless steel is much heavier than aluminium, a thinner metal sheet would be necessary to decrease the weight. This could in turn cause issues with sharp edges, strength and perceived quality.

## CONCLUSION

Of the different polymeric materials, only PPS and PEEK would be likely candidates. They can both withstand high temperatures and are flame retardant. No significant amounts of dangerous gases are released if burned and they can be used in contact with food.

Aluminium is proven to work, although it has some issues relating to thermal conductivity and scratch tendencies. Stainless steel has better properties than aluminium in terms of thermal conductivity but is in turn heavier.

# 5.3 MATERIAL SIMULATIONS

The simulations of the heat distribution were conducted using the same CAD models and software as the previous simulations, with the only modification being the material properties of the handle. These simulations show how warm a handle in these materials would get after hanging 10 minutes on an empty pot in a burning stove.

Indeed, all three alternatives show large improvements over aluminium. A handle in stainless steel would have jaws that reach high temperatures, but the temperature of the gripping surfaces would only increase a few degrees.

The simulation of PPS and PEEK provided even more promising results. The jaws would become warm, but the gripping surfaces barely measured any temperature elevation at all. See Figures 5.1 and 5.2.

These promising results lead to further investigation into plastics. However, the simulation did not provide insight regarding other issues such as direct exposure to flames or prolonged cooldown periods that may slow the packing process. Furthermore, the simulation only showed heat distribution during one specific scenario.

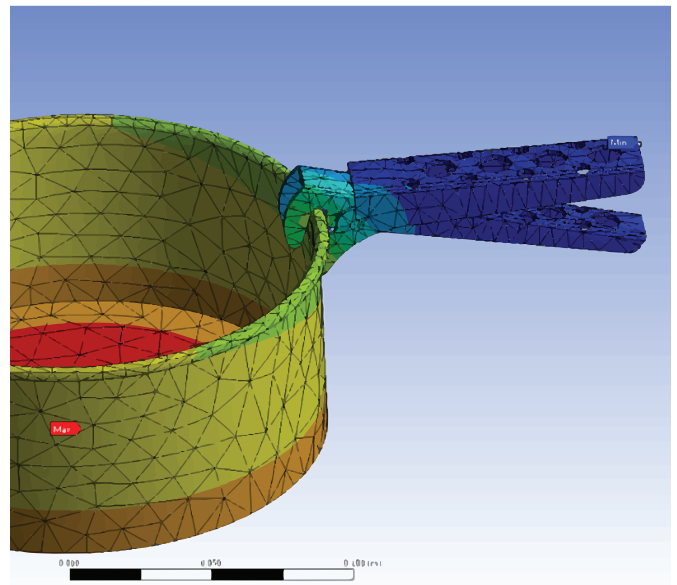

Figure 5.1 Simulation with a Stainless steel handle

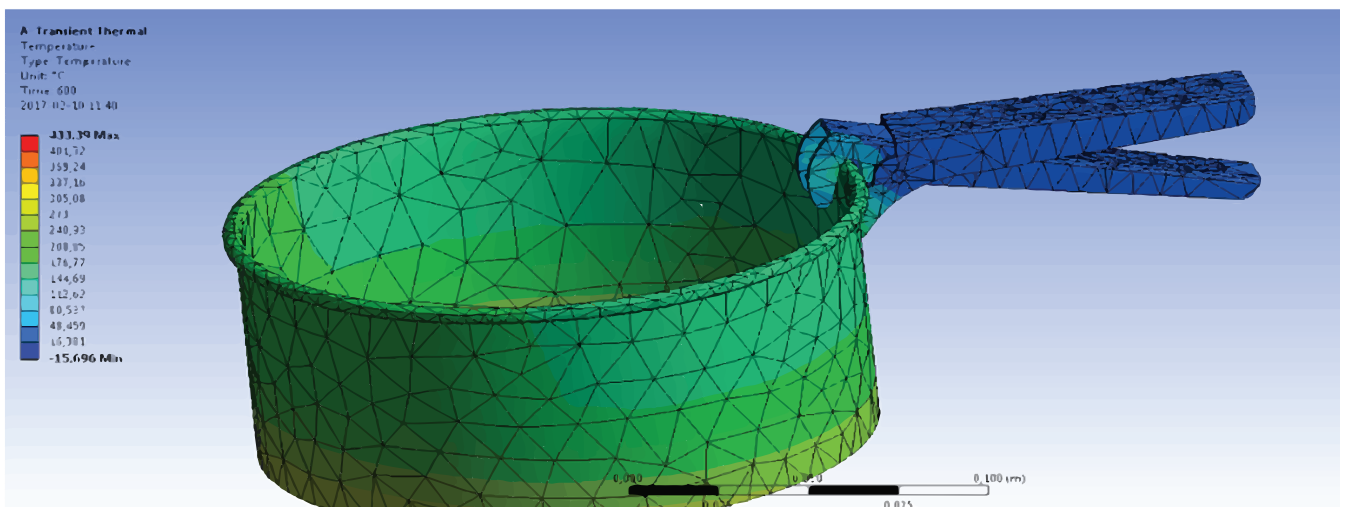

Figure 5.2 Simulation with a PPS handle

# 5.4 MATERIAL TESTS

PPS and PEEK samples were obtained from polymer suppliers, and a spoon was used as a sample for stainless steel. The samples were subjected to tests aimed at investigating their thermal and mechanical properties.



Figure 5.3 The measuring process

## TEMPERATURE TESTS

The tests were conducted in a ventilated area indoors, with an ambient temperature of 21°C. Material samples were placed in contact with the surface of a boiling pot in a Trangia stove. A probe was attached to the samples, and the temperature was noted every 15 seconds. Each polymer was subjected to two tests. The samples were wedged between the windscreen and the pot to simulate the jaws, and placed close to the pot edge, protruding outwards, to simulate the gripping surfaces. See Figure 5.3 for the measuring process.

Similar tests were performed on the stainless steel sample. However, since stainless steel would not reach its melting point, the temperature was solely measured at the gripping surfaces rather than the jaws. A first test was conducted with the spoon resting on the top of the windscreen. A second test was then conducted where the sample was bent and placed between the windscreen and pot with the handle protruding outwards.

## Results

All three materials produced promising results. The temperature of the gripping surfaces did not reach anywhere close to the limit of 45°C. For PPS, the gripping surface reached a maximum of 22.8°C. PEEK produced similar results at 23.7°C, while stainless steel reached 25.8 °C. However, PEEK had a lower jaw temperature at 38.4°C, while PPS reached 58°C. See Figures 5.4-5.6.

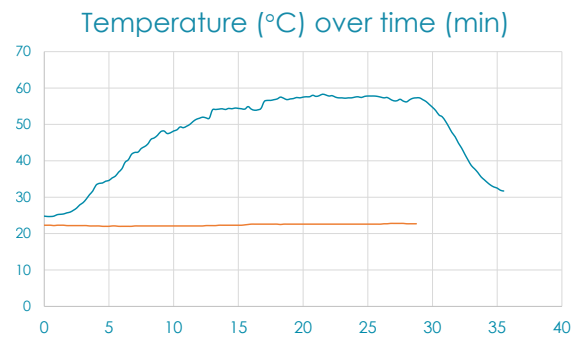

Figure 5.4 Temperatures of jaw, blue, and gripping surfaces, red, for PPS

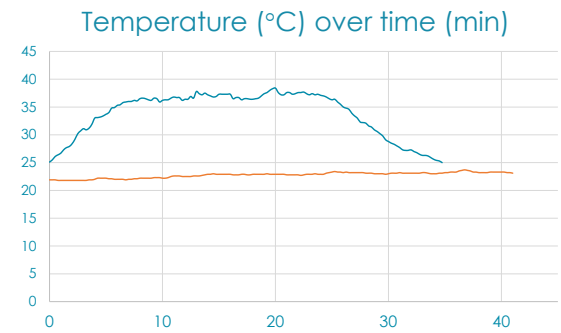

Figure 5.5 Temperatures of jaw, blue, and gripping surfaces, red, for PEEK

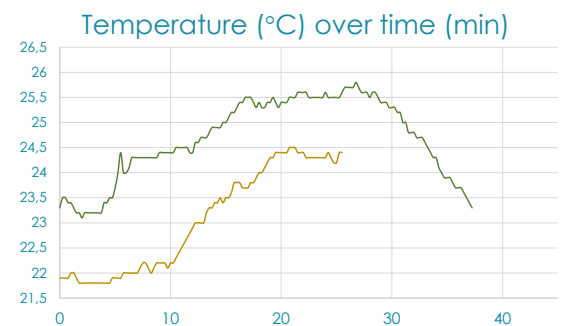

Figure 5.6 Temperatures of submerged, green and non-submerged, yellow stainless

## DEFORMATION TESTS

Tests were conducted to investigate the materials' ability to resist deformation. To simulate an authentic use scenario, the samples were used to fold the pot holders up with an ignited burner mounted in the windscreen. The samples were then placed directly above the burner to investigate how long they could withstand the heat without any melting or deformation occurring. The samples were subjected to impact tests in which they were thrown onto a concrete floor from a height of 5 meters. The samples were also bent by hand, to observe if any fractures or breakage occurred. The tests were performed on samples of PEEK, aluminium, pure PPS and fibre-reinforced PPS:es with 40% glass fibre, 30% glass fibre, 40% carbon fibre and a combination piece with PTFE and glass fibre. See figures 5.7-5.9 for results.

### Results of deformation tests

All samples of PPS managed to fold the pot holders up slowly without deforming or even experiencing any significant temperature increase. This indicates that the material should be able to safely withstand temporary contact with the burner flames. However, the pure PPS sample deformed and began to smell after 20 seconds within the burner flames. The 40% glass fibre-reinforced PPS produced a visible minor deformation after 20 seconds and severe deformation after 30 seconds. The 30 % glass fibre-reinforced PPS and carbon fibre reinforced PPS deformed slightly more than the 40% reinforced. The PTFE-mix deformed severely after 30 seconds and maintained plasticity for a significant amount of time during cooldown.

PEEK plastic produced minor deformation after 20 seconds. At the 30 second mark, significant deformation were observed. However, it should be noted that PEEK deformed less than PPS. The existing aluminium handle blackened after a very short period of time, and deformed marginally after 1.5 minutes of direct exposure to the burner flames. That deformation is however very small, and would be hard to notice without comparison before and after. During the impact tests, none of the samples broke when thrown to the ground with significant force. The bending test showed that even the 40% glass fibre PPS is possible to break, but it would take significant effort to do so.



Figure 5.7 Deformation of pure PPS after 20 seconds



Figure 5.8 Deformation of 40% glass-fibre reinforced PPS; 20 seconds on the upper half of the piece and 30 on the lower



Figure 5.8 Deformation of PEEK; 30 seconds at the top of the image below, and 20 on the bottom of the image.

## SCRATCH TESTS

Tests were conducted on a non-stick frying pan as well as a pot to simulate the materials' potential scratching. Both sharp edges and smooth surfaces of the samples were tested.

Corresponding to the theory in Chapter 4.2, pressing sharp edges of the samples to the pots or pan surfaces will always cause scratches. Aluminium produced the deepest and most severe scratches, while PPS and PEEK only produced very shallow marks.

When using the smooth surfaces, scratching was significantly reduced. The PPS and PEEK samples did not produce any visible scratches at all, and the aluminium only produced minor scratches. However, the smooth aluminium surface still had sharp edges which did produce significant deformations.

## 5.5 CONCLUSIONS

The different materials all have benefits and drawbacks. PPS and PEEK allow for a wider variety of shapes with a lower weight, they have less thermal conductivity and would be less likely to cause scratches and dents on the pots. The materials could withstand the occasional flames while hanging on the pot edge. However, no PPS or PEEK sample were able to withstand close direct exposure to the burner flames for more than 20 seconds without deforming. The deformations are however small, and a handle would still be able to function despite them. However, the perceived reliability and quality of the product would likely decrease afterwards. Furthermore, a PPS or PEEK handle would most likely have a shorter lifespan than a metal handle and they would require completely different manufacturing techniques than the current handle.

A stainless steel handle would be stronger and have a lower thermal conductivity than the current aluminium handle. It is also likely that a stainless steel handle would reduce some of the scratching as the formed chromium oxide is softer than aluminium oxide. However, stainless steel would lead to a higher weight and thinner material sheet, which in turn will cause sharper edges on the handle. A handle in aluminium would suffer from the same problems as the currently used, although there are options to still improving the scratch and heat issues. It is possible to redesign the jaws and mechanisms to reduce sliding and scratching, or add plastic protectors to the jaws; either by coating the jaw or creating a plastic detachable cover. To try decreasing the temperature, it would be possible to look over holes and surface treatments such as plastic or paint coatings.



# 06

## REQUIREMENTS

The findings from the previous chapter lay the foundation for the requirements. Requirements were defined for both the handle as well as for every part of the entire stove. The stove requirements were based on the found problems, and do not state what the stove already does and must do.

These lists can be found in Appendices 6 and 7.

# 6.1 HANDLE FUNCTIONS

The main function of the handle is to grip the pots and pans. It must be able to grip all existing Trangia pots in a safe and stable way without allowing the handle to slide along the pot edges. Moreover, it must also be able to grip the windscreen, adjust the pot holders and should preferably be able to use when adjusting the simmer ring. Other functions or areas of use could be possible to add as well. It must also be easy to open and close the handle, and it must not obstruct the user when using the pots. Moreover, the parts of the handle must be possible to grip separately, to facilitate separation if the handle freezes shut or gets jammed. The handle shall also avoid opening or closing against the user's intentions, and cause as little rattling as possible.

# 6.2 CONSTRUCTION

The handle should have a long lifespan to match the other parts of the stove. The performance must not decrease over time, and even if the handle breaks, it should not fail so severely that it cannot be used to hold pots until replaced. It must also be able to withstand rough handling and tough weather. If necessary, it should be possible to repair the handle. Furthermore, the handle must be able to withstand the heat of the pots and the flames of the burner. It should also maintain a safe temperature in the gripping surfaces. Additionally, the handle must be able to work in cold environments without freezing shut.

In terms of aesthetics, the handle should preferably be streamlined and nimble. It should not have protruding parts that may get stuck in other objects. Regarding manufacturing, the handle should be possible to manufacture using standard equipment and processes. It should consist of few parts and be easy to assemble. Ideally, each handle should cost less than 5 SEK to manufacture. Furthermore, the handle should harm the environment as little as possible and be possible to recycle.

## 6.3 MATERIAL DAMAGES

Some of the most important requirements refer to the handle's ability to avoid scratching the surfaces of the pots. The handle should not scratch the pots during use or when stored in the stove. Neither shall it deform the edges of the pots. To fulfil these requirements, the inner jaw must not slide sideways along the axis of the rivet. The jaws should also be able to close without causing temporary pressure points, and it must not slide along the pot on its own each time it is opened. No sharp edges should exist on the jaw, and the contact surfaces between pot and jaw should be smooth. Furthermore, the pots should not slide or shake when lifting them, and the contact surfaces of the jaws could consist of a softer material.

## 6.4 MISCELLANEOUS

The handle must be comfortable to grip and hold for prolonged times, and it must not require a strong grip to keep it closed. The gripping surfaces must not have sharp edges that can cause harm or discomfort, and the user should not be able to pinch their hands when using the handle. Preferably the handle should be comfortable to hold at all times, whether it is open, closed or when transitioning between the two. Users should be able to use the handle while wearing gloves, or if they have reduced motor skills. It should also be possible to hold the handle using a variety of grips. Overall, the handle should be intuitive to use. It would also be advantageous if the handle could be made somewhat lighter than the current one.

The handle should fit comfortably into the hands of most users, ranging between the 5th and 95th percentile. It must be able to fit within all stoves and kettles, and the users should even be able to fit two handles within the same stove. Ideally, the handle should have a specific resting place within the stove that keeps it still. Furthermore, the handle must be easy to identify at the camping site even during dim light.

It is very important that users feel that they can trust the handle at all times. They must experience it as sturdy and robust while lifting the pots and it must be experienced as durable and thought-through. Furthermore, all surfaces of the handle should be easy to reach and clean. The visual product expression of the handle should fit the Trangia brand identity. In this, the Trangia logo should have a natural place on the handle, and it should be regarded as aesthetically pleasing.



# 07

## FIRST CONCEPTS

The concept development phase was based on requirements and use situations, as well as discussions with Trangia. The process was iterative, involving multiple ideation, sketching and evaluation stages. The first iteration explored different mechanisms for suspension and locking by the aid of sketching and making physical models.

# 7.1 CONCEPT DEVELOPMENT

The ideas were sorted into four main categories based on the found mechanisms; rotational, caliper-like, additional fastenings and semi-permanent handles. These ideas were refined in the second iteration which resulted in additional subcategories for the next loop. The mechanisms were validated using rudimentary models, while clay models were made in order to explore different shapes. The shapes were tested on six users, and the result was used in the next ideation loop. A final round of brainstorming and sketching was used to generate concepts leading to five handle concepts that were modeled in Catia V5, 3D-printed and evaluated. The complete results of the ideation can be found in Appendix 7.

The first five concepts are centered on shapes and mechanical features. The aim was to explore potential locking and closing mechanisms as well as generate comfortable gripping surfaces.

Manufacturing processes and material selection were not specified at this stage. Furthermore, the jaws were left unchanged.

All five concepts are equipped with locking mechanisms or another method aimed at assuring a safe grip for two important reasons. A lock will serve to maintain a secure grip on the pots regardless of the strength of the users' grip.

This should increase the trust in the handle and minimize the risk of burns. Additionally, a handle that has been locked in place on the pots should be less likely to disappear.

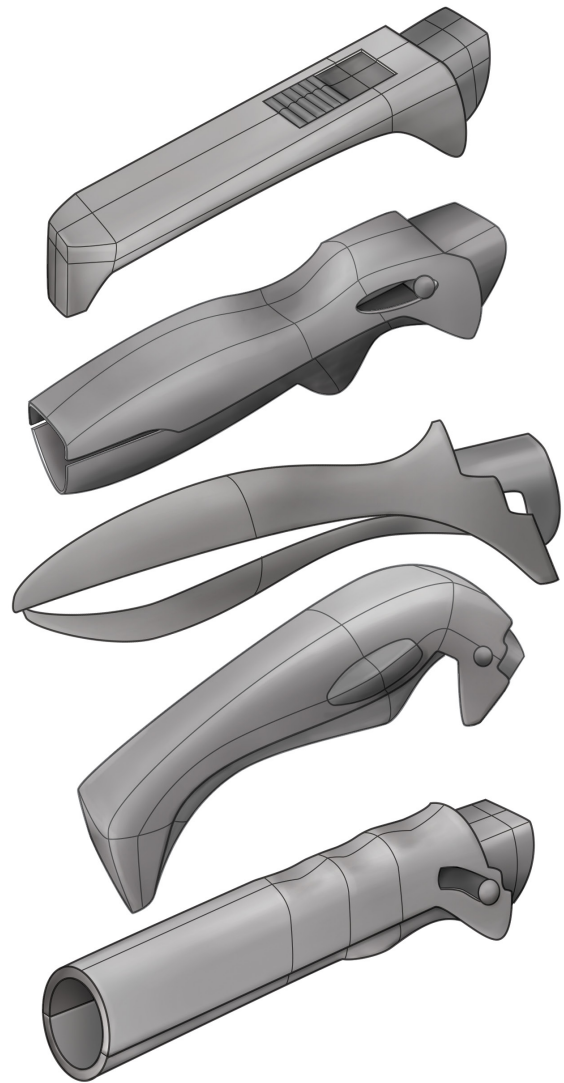

Figure 7.1 Sketches of the first five concepts

# 7.2 CONCEPT PRESSLOCK

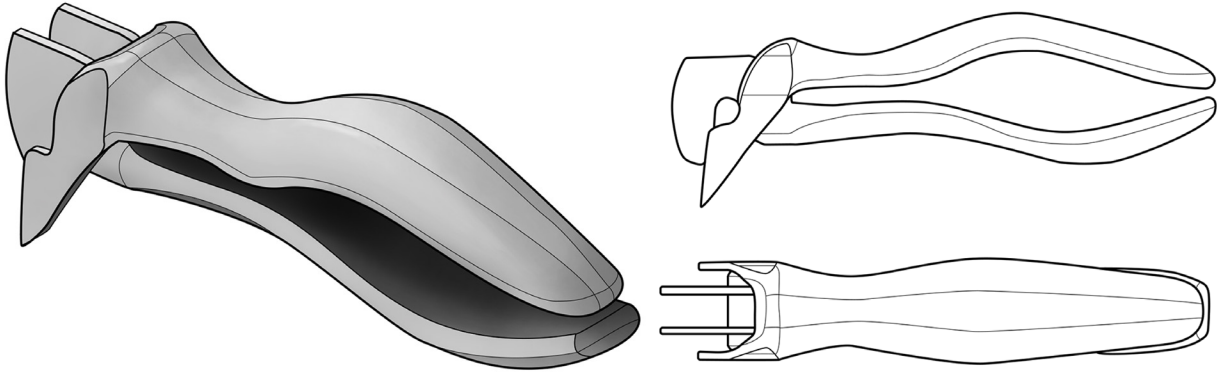

Figure 7.2 Concept Presslock

Concept Presslock use the same rotational plier mechanism found in the current handle. However, Presslock can also be locked in closed position by pressing down the upper part and thereby move the rivet rod into a cavity. The shape of the rod and the cavity prevents the handle to open, see Figure 7.3. A similar lock can be found in pipe-wrenches. To unlock the handle, the user simply pulls the upper part upwards.

Presslock has a smooth, flowing shape inspired by ergonomic pliers. The thumb has a natural resting position on the top, as has the index finger on the lower side. The handle bulges outwards at the rear end for comfortable palm and finger grip. See Figure 7.2.

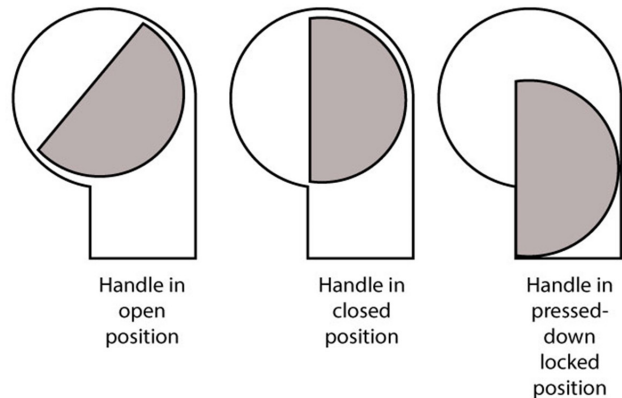

Figure 7.3 The Mechanism of Concept Presslock. The rotational rod in grey and the cavity where it can move in white.



Figure 7.4 Presslock being held in a hand



Approaching the pot



Taking a grip on the pot



Gripping the pot



Lifting the pot



Leaving the handle



Pressing the top downwards



Leaving the handle locked



Pulling up to open lock

Figure 7.5 Using Concept Presslock

# 7.3 CONCEPT DOWNSLIDE

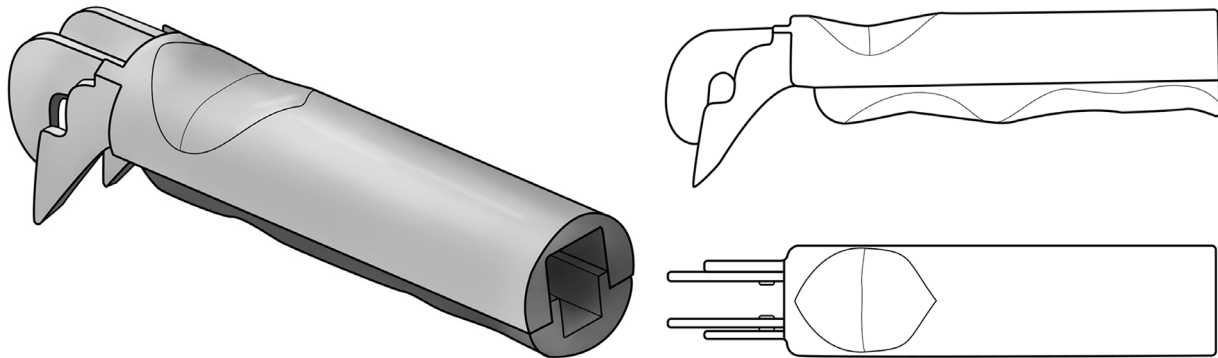

Figure 7.6 Concept Downslide

Concept Downslide is based on a calliper mechanism, in which the two halves move along a slanted rail. The slant assures that the handle is easy to close, as it will force the handle shut when the user take a hold of the handle. The handle will then stay closed until the user slides the top half backwards.

The mechanism allows a more secure grip around the pots without adding a locking mechanism. Furthermore, connecting the parts via the rail will decrease the gap between the parts and thereby minimise sliding. See Figure 7.7.

The main shape is based on a simple but rather comfortable cylinder. The top has a slight submersion for the thumb which can

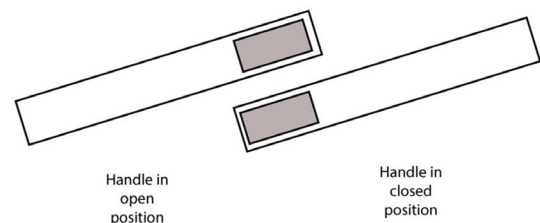

Figure 7.7 The Mechanism of Concept Downslide. The slide rod in grey and the rail cavity where it can move in white.

be used to manoeuvre the closing mechanism. The lower gripping surface has a very subtle waveform allowing comfortable finger placement without forcing specific grips. As the two gripping surfaces move significantly less than the current handle, the change in grip between an open or closed handle is small and comfortable. See Figure 7.6.



Figure 7.8 Downslide being held in a hand



Approaching the pot



Prepare for gripping



Pressing forward to grab pot



Lifting the pot



Leaving the handle closed



Sliding back to open handle



Leaving the handle open



Removing the handle

Figure 7.9 Using Concept Downslide

# 7.4 CONCEPT SPRINGSLIDE

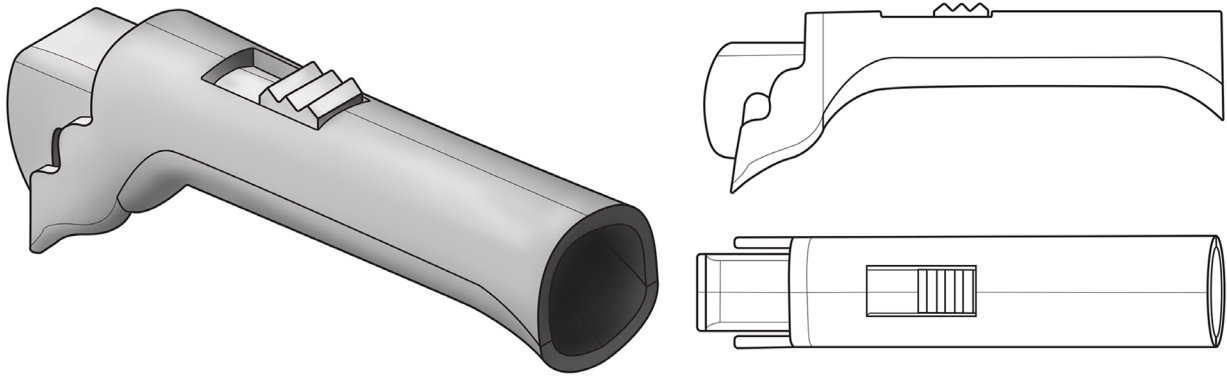

Figure 7.10 Concept Springslide

Concept Springslide consists of a horizontal calliper mechanism and a spring that pulls the jaws closed. The user can open the jaws by pushing the top button forward. The jaws will therefore remain closed, allowing the handle to keep hold of the pots regardless of the users' handgrip. See Figure 7.11

The shape is fairly simple and is based on a rounded rectangle. The lower gripping surface curves downwards at the back to prevent the hand from sliding off the handle. To prevent the handle from opening by accident, the button is located slightly behind the thumb's resting place. Because of the mechanism, the handle would need to be made out of three parts to facilitate assembly. See Figure 7.12.

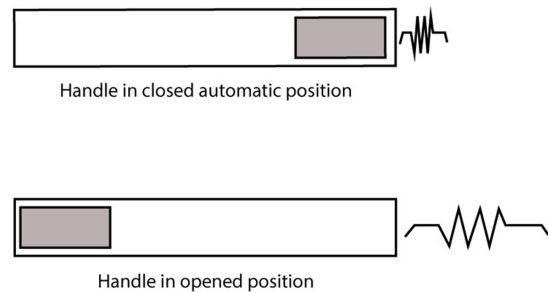

Figure 7.11 The Mechanism of Concept Springslide. The slide rod in grey and the rail cavity where it can move in white, together with an opened and closed spring.



Figure 7.12 Springslide being held in a hand



Approaching the pot



Slide forward to open



Prepare gripping



Let the finger go to hold



Lifting the pot



Leaving the handle



Sliding forward to open



Removing the handle

Figure 7.13 Using Concept Springslide

# 7.5 CONCEPT PINLOCK

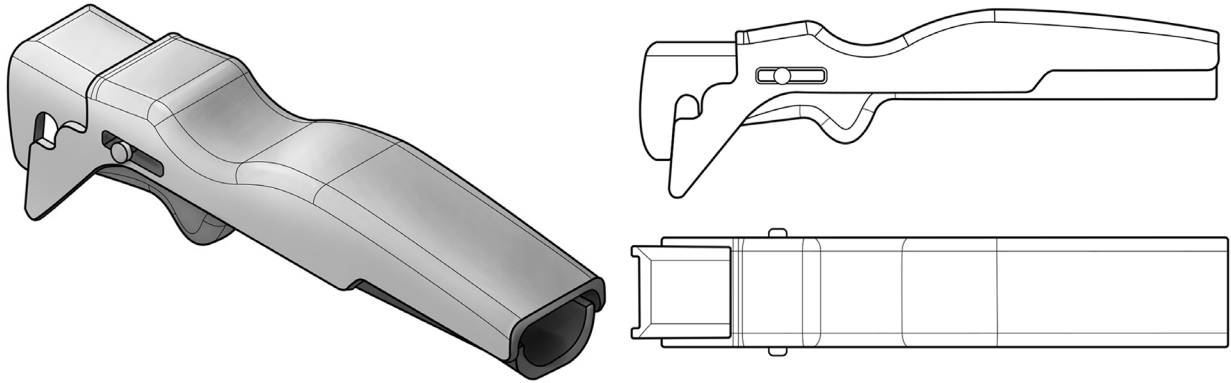

Figure 7.14 Concept Pinlock

Concept Pinlock is based on the rotational mechanism of the existing handle. The handle is equipped with a locking pin which allows the user to lock the handle in place whenever the user deems it necessary. The user can lock the handle by pushing the locking pin backwards, otherwise it works like an ordinary plier based handle. See Figure 7.15.

Pinlock has a rectangular base shape. The upper gripping surface has a submersion for the thumb and the lower has a protruding rest for the index finger. The form language provides the users with clues on how to hold the handle and is reminiscent of ergonomic tools, see Figure 7.14.

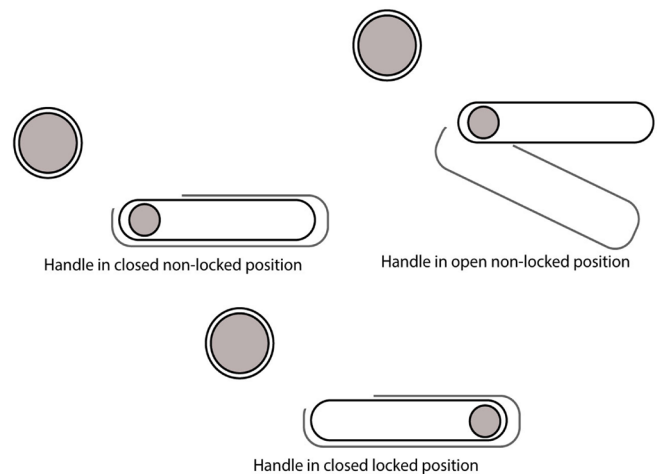

Figure 7.15 The Mechanism of Concept Pinlock. The rotational rod and pin rod in grey, with cavities to move in white. The pin cavity in the inner part of the handle is in light grey.



Figure 7.16 Pinlock being held in a hand



Approaching the pot



Taking a grip on the pot



Lifting the pot



Leaving the handle open



Dragging the pin backwards



Leaving the handle locked



Dragging the pin forwards



Removing the handle

Figure 7.17 Using Concept Pinlock

# 7.6 CONCEPT SNAPBUTTON

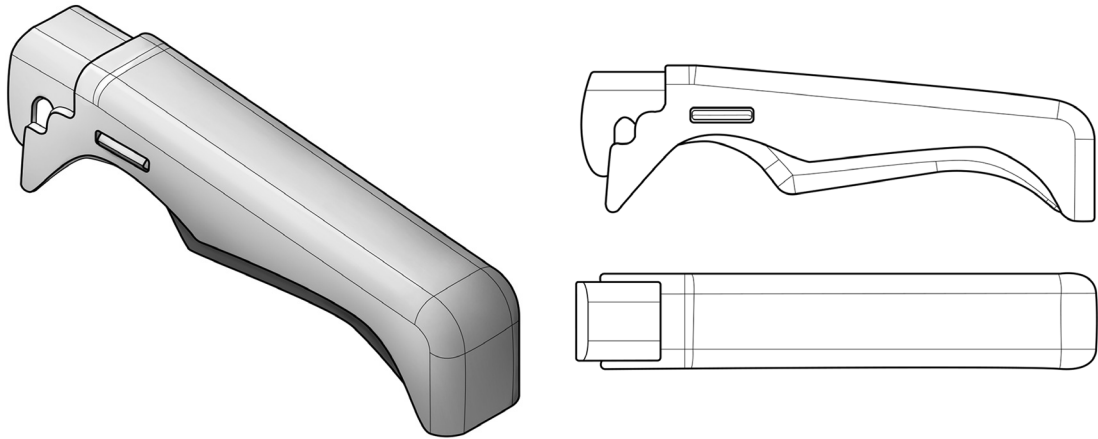

Figure 7.18 Concept Snapbutton

Concept Snapbutton use a plier mechanism, this time combined with two flexing buttons for locking the handle. The buttons are inspired by the snap-locks found in, for instance, backpacks and are located on the sides of the handle. The handle is automatically locked when closed, and may be released by pressing both buttons simultaneously. See Figure 7.19.

Snapbutton is inspired by the existing handle. It combines the rectangular shape with a smooth underside. The gripping surfaces are slightly angled downwards to increase the comfort, and have a curved edge at the end to prevent the hand from sliding off. The buttons are located just above an index finger rest, allowing easy access to the locking mechanism while avoid an accidental release. See Figure 7.18.

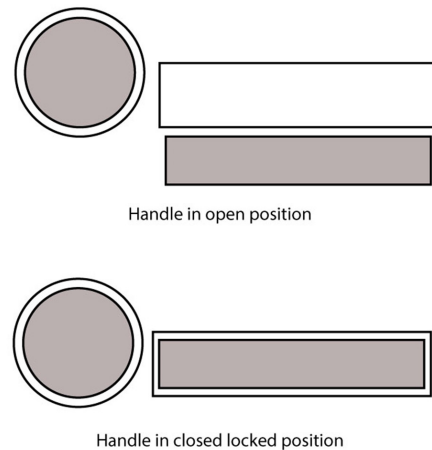

Figure 7.19 The Mechanism of Concept Snapbutton. The rotational rod and the button in grey, with the cavities in which they rotate, and can be pushed into respectively, in white.



Figure 7.20 Snapbutton being held in a hand



Approaching the pot



Prepare gripping



Gripping the pot



Lifting the pot



Leaving the handle on the pot



Pressing the buttons to open



Leaving the handle open



Removing the handle

Figure 7.21 Using Concept Snapbutton



Figure 7.22 The 3d-printed models open and closed

# 7.7 CONCEPT TESTING

The concepts were tested on ten experienced Trangia users to obtain feedback. Four participants were recruited from the questionnaire and were interviewed individually while the remaining six users served as a focus group. The participants were then instructed to hold and use the handles on Trangia pots before rating them. They were asked to grade the handle individually according to comfort, functionality and aesthetic appeal using a scale ranging from 1-6.

The users were also asked which aspects they liked and disliked in the handles. After grading each handle, the users were asked to name their overall favourite, preferred mechanism and shape. Finally, users were asked how they would combine aspects into an ideal handle. The full questionnaire can be found in Appendix 8. Besides the user tests, the concepts were evaluated against the requirement list and through discussions with Trangia.

## RESULTS

Feedback from the tests and evaluations were summarized in tables listing the positive and negative traits of each concepts. One table regarded mechanisms and another regarded shapes. The full tables are found in Appendix 9, and a summarising table in Figure 7.23.

Presslock was regarded as simple to use with an easy locking mechanism. The users liked that it did not lock automatically, but found that the shape of the handle made it hard to unlock. Some users expressed concern that the cavity and rod would be subjected to wear and thereby lose functionality over time. However, most users believed that the handle would be possible to use despite a broken lock. Furthermore, the users found it to be comfortable to hold and stated that the open space between the parts made the handle appear lighter than it actually is.

The novelty of Downslide was appreciated. The users liked that the handle did not require a lock to stay closed. They also liked

that it only required one hand to open and close and found the transition between to be smooth. However, while the cylindrical shape was comfortable it was also found boring and the smooth surfaces made it difficult to open the handle. It was also found that the cylindrical rod unintentionally allowed the handle to act as a plier. Some users were unsure of Downslide's ability to stay closed while lifting and pouring heavy pots, leading to discussions regarding the angle of the slope and the possibility to introduce a friction lock.

Users appreciated the thumb motion used to unlock Springslide, and it was stated as likely to work well when wearing thick gloves. However, the users expressed concern regarding the reliance of a spring mechanism as it was seen as a fragile construction and the spring would need to be very strong in order to maintain its grip. This could make it very difficult to open the jaws. Moreover, the handle would no longer be able to function if the spring fails or gets detached. Additionally, the handle consists of more parts to assemble which could make it expensive to manufacture.

	Presslock	Downslide	Springslide	Pinlock	Snapbutton
Preferred shape					
Preferred mechanism					
Preferred handle					

Figure 7.23 Counting of preferred shapes, mechanisms and handle overall.

Pinlock was regarded as simple to use and the ability to decide whether or not to lock the handle using the pin was appreciated. Users however expressed fear that the pin might end up askew or be an obstruction when closing the handle. Some users found that the pin was hard to reach comfortably, and others expressed that it was too hard to lock.

Snapbutton was seen as an intuitive concept, but less realistic than the others. The fact that the outer part is pressed inwards when pushing the buttons make it harder to release the handle. Prying open a jammed handle would be hard as well, since the lower part is submerged into the upper part. Users also expressed concerns regarding the lifespan of the buttons.

Downslide had the most frequently preferred mechanism because of its simplicity and safe grip. Presslock had the most preferred shape because it appeared light and provides a comfortable grip for larger hands. In contrast, Springslide received poor aesthetic remarks as the users experienced it as large and heavy.

### Combinations

Only three users were asked to combine aspects of the handle. The first suggestion was to combine the mechanism of Presslock that unlocks similarly to Snapbutton. The second suggestion was to combine Downslide's mechanism with the shape of Snapbutton while the third suggestion was to provide Downslide with a flatter underside.

## 7.8 CONCLUSIONS

It became clear during the tests that users differ in their opinion regarding the usefulness of a locking mechanism. Some users would prefer a locking mechanism and see it as a positive change while others are very sceptical and believe that it would do more harm than good. Users tended to prefer the locking mechanisms where the user had to lock the handle manually. They did not appreciate more advanced mechanism, such as Springslide, as they regarded them as more fragile and unsafe.

While it may seem obvious, the test showed that it is hard to design a handle that will fit perfectly into every user's hands. Furthermore, opinions regarding the concepts with pronounced finger rests were more affected by the user's hand size and shape. Such features should therefore be constructed with great care.

The users were divided in two groups; those who preferred a sliding mechanism and those who preferred a plier. Downslide had the most popular mechanism overall and should therefore be refined in the next concept phase. The other concept should be based on a plier mechanism that draws from all three plier concepts; Presslock, Pinlock and Snapbutton.

# 08

## SECOND CONCEPTS

For the second concept phase, manufacturing and assembly was added as constraints to the ideation process. Based on the material investigation, user studies, concept evaluation and discussions with Tran-gia, the handle was decided to remain in aluminium.

# 8.1 CONCEPT REFINEMENT

The rationale behind the decision to use aluminium was that PEEK would become too expensive and stainless steel would be too heavy and have sharper edges. Moreover, although PPS is both lighter and cheaper, it still deforms after 20 to 30 seconds of exposure to the heat of the combustion flames. It would also require different manufacturing techniques and would most likely have to be manufactured by a third-party supplier.

Finally, users indicated that they would trust a plastic handle less than a metal handle. This distrust would only increase if the handle deforms after being used to, for example, adjust the simmer ring. Furthermore, a plastic handle would need to overcome the negative associations that many users have with the material.

By stamping and bending the parts of the handle from a 2 mm thick aluminium sheet, the current manufacturing process may be kept. Naturally, the material and manufacturing process leads to significant changes in the form language of the handles compared to the previous concepts. Only single curved surfaces are used, and the 2-mm bending radius and hole placement need to be considered.

To counteract the problem with scratching the concepts explored different ideas for redesigned jaws. Furthermore, the handles should be treated to dull the edges and could be coated in a bright colours. As stated in chapter 5, by adding a layer of paint the handle becomes cooler and will become easier to identify at the camping site. Lastly, because aluminium has a high heat distribution coefficient, adding a locking mechanism is problematic as it may lead to increased temperature elevation if handles stay attached to the pots for a prolonged duration.

The concepts were developed by sketching and physical modeling as part of an iterative process. Models were built in Catia Generative Sheet Metal Design, to assert that production by stamping and bending would be possible. For the complete development, see Appendix 10.

## 8.2 CONCEPT GRIPSLIDE

Concept Gripslide is based on a slanted rail that connects the two main parts. Instead of rotating, the handle slides into place to secure a stable grip around the pot edges. This feature eliminates the risk of pinching, it makes it easy to open and close the handle without changing the grip and most importantly - it significantly reduces scratching and denting. Furthermore, as there is only a slight change in the position of the gripping surfaces, Gripslide is equally comfortable to hold in open and closed position.

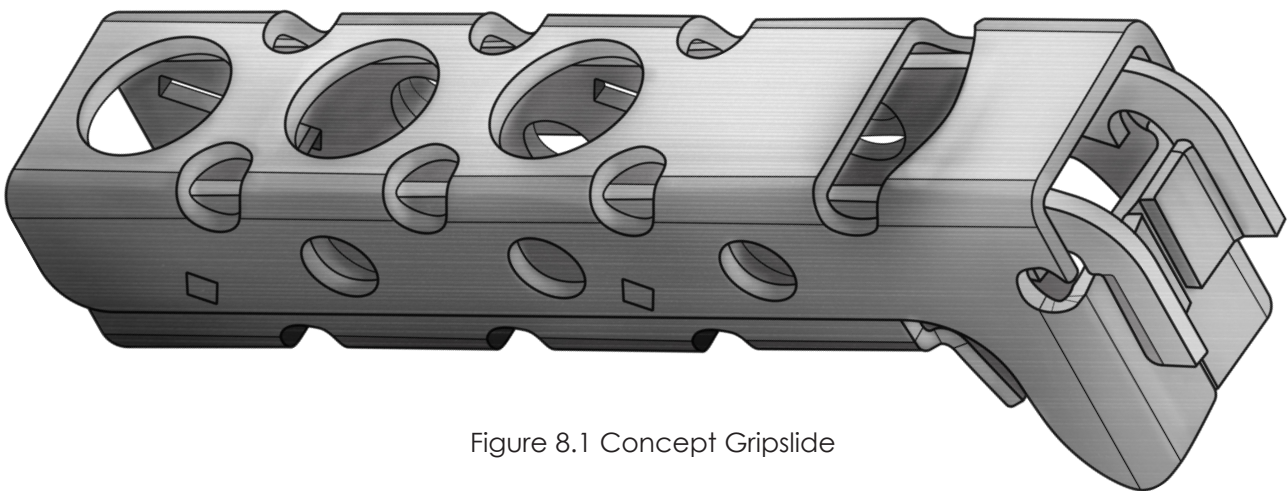

Figure 8.1 Concept Gripslide

The close fit between the shape of the jaw and the pot edge ensures that the handle will stay in place. This means that Gripslide reduces the risk of dropping pots when users hand the pots over to each other. The mechanism manages to assure that the handle is closed without the need for a locking mechanism which makes it easy to open the handle. By loosening the grip and pushing the index finger against the finger rest, the jaws are separated. The thumb can then either stay in its current position or be placed at the thumb shaped hole at the top for additional support.

The jaws of Gripslide are made to scratch the non-stick coating as little as possible. The sliding movement makes the entire jaws get in contact with the pots at the same time, preventing pressure points that cause scratching. Using a rail will minimise the gap between the two parts, and thereby reduce the sideways sliding that constantly damage pots. The con-

tact surfaces are large and smooth, allowing the pressure to be distributed against a larger and more even area. These surfaces are formed from an extra bending step, and use an angle of  $85^\circ$  to fit perfectly around the pot edge. There are no sharp edges close to the pot surface and the jaws are shaped to provide an improved grip and decrease the handle's tendency to slide along the edge. When the handle is opened, the surfaces are gently removed simultaneously. If needed, the jaws could be fitted with a plastic protector to further maximize the protection against scratches. See Figures 8.1 and 8.2.

### MANUFACTURING

The new jaws and the finger rest could require a more advanced bending operation. While they should be able to be bent at the same time, there is a slight risk that the bending would have to take place in two steps. De-



Figure 8.2 Concept GripSlide held in a hand

spite the new surfaces the overall weight of the product would stay the same. However, since the handle has two rails, two rods have to be assembled and riveted instead of one. Arranging the parts on a metal band leads to a scrap factor of 20% between the parts and 35% if the holes are considered. This is comparable to the 30% scrap factor between the parts and 35% with holes included of today. See Figure 8.3 for possible arrangement in manufacturing.

## BRANDING

GripSlide keeps the classic holes from the old handle, which makes it fit into the same family. Dimensions and relations of the holes are similar, and the bending radius is the very same as for the old handle. The Trangia logotype and “made in Sweden” are stamped onto the handle and placed in a prominent way. The focus on function before form is also a clear brand trademark of Trangia’s and should inspire a high degree of trust in the handle’s ability to perform at all times.

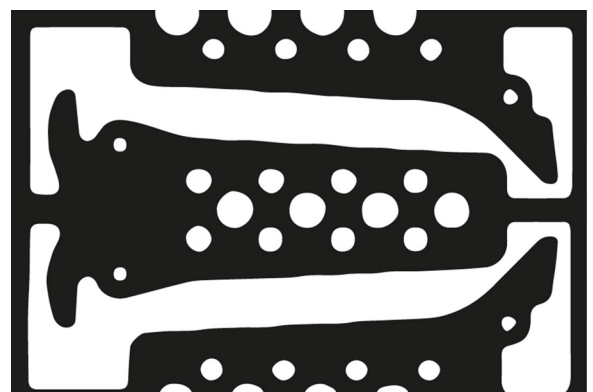
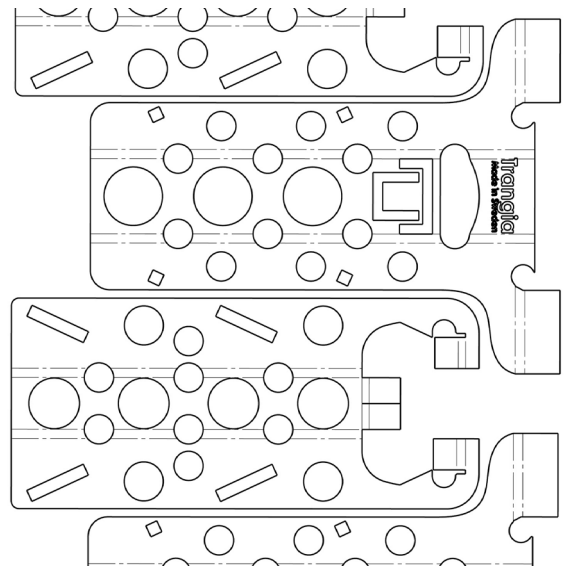

Figure 8.3 Stamping of GripSlide and the old handle



Approaching the pot



Prepare for gripping



Holding together to grab pot



Lifting the pot



Leaving the handle closed



Sliding back to open handle



The handle opens



Removing the handle

Figure 8.4 Using Concept Gripslide

## 8.3 CONCEPT PLIER

As with concept Gripslide, Plier was created and developed using iterations of hand sketches, physical models and 3D modelling. The general shape was developed from concept Snapbutton, keeping the index finger grip and square cross section. The main aspiration of concept Plier was to make a handle that looks and feels light weight in all aspects. To make the handle appear lighter, inspiration was drawn from the holes of the current handles and the aesthetics of concept Presslock. This resulted in weight reductions of up to 8 grams compared to the old handle.

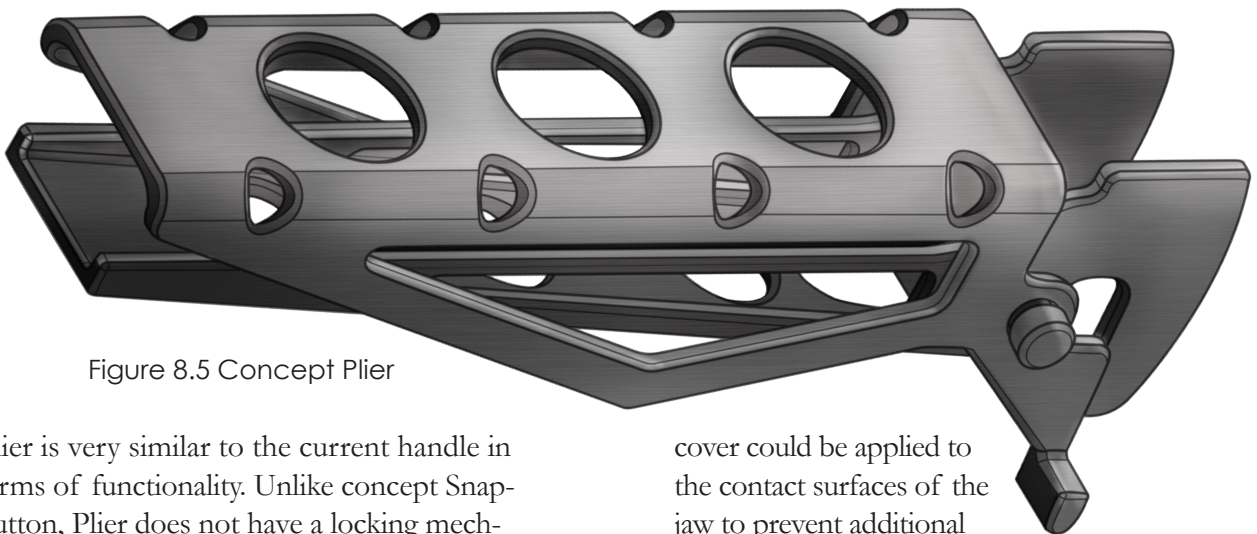

Figure 8.5 Concept Plier

Plier is very similar to the current handle in terms of functionality. Unlike concept Snapbutton, Plier does not have a locking mechanism. Instead, the functionality has been increased by modifying the jaws of the handle. As with Gripslide, the contact surfaces are bent and could be provided with plastic protectors. But unlike Gripslide, Plier has much smaller contact surfaces in an effort to minimize material. The holes that encapsulate the pot edges have also been modified to provide more space for maneuvering Plier without scratching the pot surface while at the same time providing a safe and secure grip.

### MANUFACTURING

Like the current handle, Plier consists of two main parts that are to be assembled with a rivet acting as the handle's rotational axis. To prevent sharp edges that affect the comfort and safety of the handle, the edges should be processed and dulled. Furthermore, a plastic

cover could be applied to the contact surfaces of the jaw to prevent additional sliding and allow the gripping surfaces to better maintain a safe and stable temperature. Like Gripslide, Plier has a more complex bending process but it is unlikely that bending would require more than one step to realize.

### BRANDING

Plier is designed to provide a clear sense of belonging to the Trangia brand. It makes use of a square cross section, circular holes and maintains a similar jaw shape. The Trangia logo should be stamped onto Plier in a prominent place on the upper gripping surface. While these form elements demonstrates the Trangia heritage, the index finger grip and side cutouts push the boundaries for the Trangia form language by introducing angled shapes. Through the use of large cutouts and holes, the handle is able to appear and be lightweight.



Approaching the pot



Prepare for gripping



Pressing together to grab pot



Lifting the pot



Putting the handle down



Leaving the handle



Taking the handle



Removing the handle

Figure 8.6 Using Concept Plier

## 8.4 EVALUTATION

Seven users were recruited to test and rate the two handles. Most of them were recurring participants from the user study, meaning that they were aware of the problems that the concepts aimed to solve. The participants were asked to hold the handles and try them on the Trangia pots. They were then asked to rate the handles from 1-6 in terms of comfort, usability and mechanisms. Moreover, they were asked to state what they liked and disliked with the concepts and which handle was their favourite, see Appendix 11. A focus group consisting of nine participants with the same background as, and partly overlapping with, the last focus group were also asked to try the handles and provide feedback. Finally, to assert manufacturability the concepts were discussed with Associate professor in Material and Manufacturing Gustav Holmqvist, who work with cutting and processing.

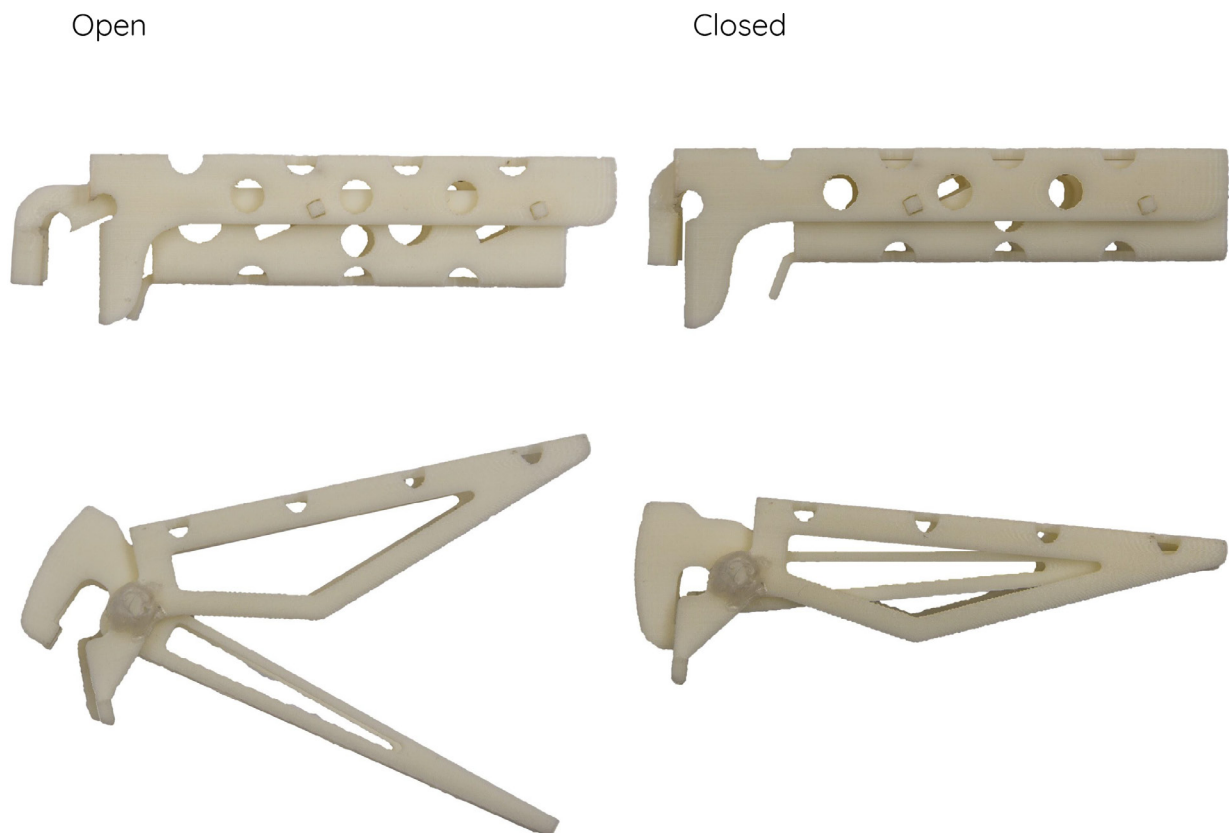

Figure 8.7 The two concepts in open and closed position

## RESULTS OF THE USER STUDIES

GripSlide was regarded as more comfortable than Plier by all but one of the test participants. It received an average rating of 4.6 compared to 3.3. This difference is statistically significant ( $p=0.0044$ ). GripSlide was also rated as more comfortable to hold, 4.8 compared to 3.9 for Plier. The rating of how well the transition between open and closed position work show no statistically significant differences, neither does the rating of how well the handle's facilitate different hand grips.

The aesthetic ranking show a slight advantage for GripSlide; 4 versus 3.4. This last rating is however precarious, as users often graded the handles on other factors than pure aesthetics. Four test participants preferred GripSlide, while three preferred Plier. This difference is however not significant. The same four users preferred GripSlide as a mechanism, and the same three preferred the Plier mechanism. Six of seven users preferred the GripSlide shape, which is a statistically significant difference ( $p=0.0021$ ).

The younger participants all preferred GripSlide, while the older most commonly chose Plier. It was noted that the participants who picked GripSlide tended to be more enthusiastic about their choice. Some of them passed light-hearted remarks asking when they would be able to purchase their handle.

The reasons for choosing GripSlide were various, and included its ability to stay closed while attached to the pot and the removed risk of pinching the hand. The handle was found to be easy to handle, that it felt safe and stable, its ability to better shield the fingers from the pot's heat and a more modern and thought-through feeling.

The reasons for choosing Plier were mainly the user's previous knowledge of and preference for the mechanism which made it more

intuitive as well as the users' finding it easy and safe to use, its ability to grip the pots without rattling. There were also users who prefer Plier simply because of the fact that they were sceptical towards GripSlide.

### Focus group

The results of the focus group largely correspond with the user tests. Three users preferred Plier, three users preferred GripSlide and the remaining three users were undecided. The undecided users wanted to try an aluminium prototype before picking a favourite. The opinions were equally mixed regarding which handle was most safe. GripSlide was considered to be more comfortable to hold and much more innovative than Plier. Plier was seen as more traditional, intuitive and lightweight.

The users voiced concerns regarding the side cut-outs of Plier, stating that they may affect the ability to bend the metal. The placement of the rivet was discussed as well, as the close proximity to the edge of the jaw may cause similar fractures in the aluminium as seen in the plastic model.

It was noted that misuse could cause Plier to fall off pots. The outwards bent jaw surfaces were also said to increase the risk of the handle getting stuck in other objects when packing the stove. Some users held the handle behind the dented edge, which made it feel shorter and led to a poor grip.

For GripSlide, the main concerns regarded the handle's ability to maintain hold of heavy pots with a light hand grip. Some users found it hard to understand the functionality at first glance and struggled with opening and closing the handle. Some users also questioned the handle's ability to perform other tasks than gripping pots. To reduce these issues, the participants suggested that GripSlide should have a more pronounced thumb grip and discussed different ways to guide new users.

## MANUFACTURING EVALUATION

According to Associate professor Gustav Holmqvist, the handles should be possible to manufacture without any significant difficulties. However, Holmqvist recommended that in order to assure manufacturability, tool manufacturers should be consulted. He further stated that it would be preferable if the new handle has the same bending radii as the old one, which both concepts already fulfil.

Holmqvist assessed that the new jaw surfaces would require an extra bending step and the associated increase in manufacturing costs. Furthermore, Plier's side cut-outs could pose a problem during the bending process as they could eliminate the necessary surfaces needed for the anvil. However, this is highly dependent on the tool. While there should not be any issues with stamping out Gripslide's rails using high tolerances, Holmqvist discussed that sliding an aluminium rod against an aluminium rail may lead to wear after a while. He also stated that using a round rod instead of a square one would most likely reduce the issue.

According to Holmqvist, it is uncertain if the extra bending step is less expensive than simply deburring the current jaw edges. The sharp edges could be deburred by barrelling; where the parts are laid in a rotating machine filled with small stones. Another possibility is to use a polishing machine after stamping but before bending. Coating the entire product could also be a solution as the sharp edges would be hidden beneath the coating and therefore experienced as softer.

## REQUIREMENT FULFILMENT

The concepts were evaluated and checked against the requirement list. While both concepts fulfil most requirements, Gripslide is significantly better at fulfilling requirements for scratch reduction and jaw design. The full evaluation can be found in Appendix 12.

## CONCEPT COMPARISON

Gripslide has a significant advantage over Plier in terms of innovation. The unique sliding mechanism would make Gripslide stand out on the market, and the user tests showed that it invoked a positive surprise. However, the high degree of innovation is also one of the drawbacks of Gripslide. There are no existing products that Gripslide can be compared with and the users have few references available when testing and learning the function. While the mechanism is assumed to work as intended, further testing of aluminium prototypes is necessary.

Plier, on the other hand, stands as a much safer option. The mechanism is already well known by the users and is possible to use while wearing thick gloves. Some users struggled with understanding Gripslide's mechanism at a first glance, and some desired a better thumb grip for maneuvering. Furthermore, Plier would likely be easier to clean and can be made lighter than Gripslide.

When it comes to scratch reduction and jaw design, Gripslide clearly outperforms Plier. The combination of a sliding motion and large contact surfaces will significantly reduce scratching compared to Plier. While Plier would be an improvement compared to the current handle, it still causes pressure points which can dent the pot surfaces. Furthermore, the protruding jaw surfaces could get stuck in other objects or cause issues while storing the handle.

In terms of safety, the handles have different benefits. Plier is deemed to be less likely to be left unattended on the pots. Gripslide instead minimises the risk of dropping pots while performing tasks such as handing the pots over, and provides extra heat shielding through the index finger rest. Should the mechanisms fail or get stuck, Plier is likely easier to repair while Gripslide might prove more challenging. In terms of comfort and

physical ergonomics, the results of the user studies were clear. Plier underperforms, as users found the finger rest to be uncomfortable due to its size, location and sharp bend. Furthermore, the users' hands did not receive enough support from Plier. Gripslide is on the other hand regarded as very comfortable to hold and use.

A more detailed comparison between the concepts can be found in Appendix 13.

## CONCEPT SELECTION

The two concepts were discussed with Trangia, and the relative weight of the benefits were assessed. The decision was made to develop concept Gripslide further, based on two main reasons. First, it will intrinsically decrease scratching the most and second, it will provide Trangia with a new unique product. However, Trangia want more testing to assure the reliability and functionality of the handle.



# 09

## FINAL PRODUCT

In this Chapter, the Final Product is described from different angles, including use, development, mechanical properties as well as manufacturing as sustainability issues.

# 9.1 GLIDELIFTER



Figure 9.1 GlideLifter hanging on a Trangia pot

GlideLifter is an entirely new pan grip for the classic Trangia Stove. Instead of working like an old-fashioned plier, GlideLifter make use of an innovative sliding mechanism. The two main parts of the handle are connected by two rivets fastened to slanted rails which allows the upper half to slide downwards to grip around the pot edge. This mechanism significantly reduce handle induced scratches and dents and eliminates the risk of pinching the hand on the handle.

GlideLifter is comfortable to hold and use. The increased height of the sides is kept constant throughout the product, leading to a smooth grip with better support for the hand. By providing the handle with a lower gripping surface, the fingers receive a comfortable and intuitive place to rest and hold. Moreover, GlideLifter has a comfortable index finger rest on the underside as well. The surface serves to facilitate control of the mechanism as well as protecting fingers from the pot's heat.

The handle can be opened in two ways. The user either release the grip of the lower gripping surface and pull the upper gripping surface backwards or push the index finger against the rest while placing the thumb in the thumb rest located at the upper gripping surface and pushing the thumb backwards. When preparing to grab a pot, the two pieces will fall apart due to gravitation and the handle will open automatically. When the handle is attached to a pot, gravity will instead aid in keeping the handle closed.

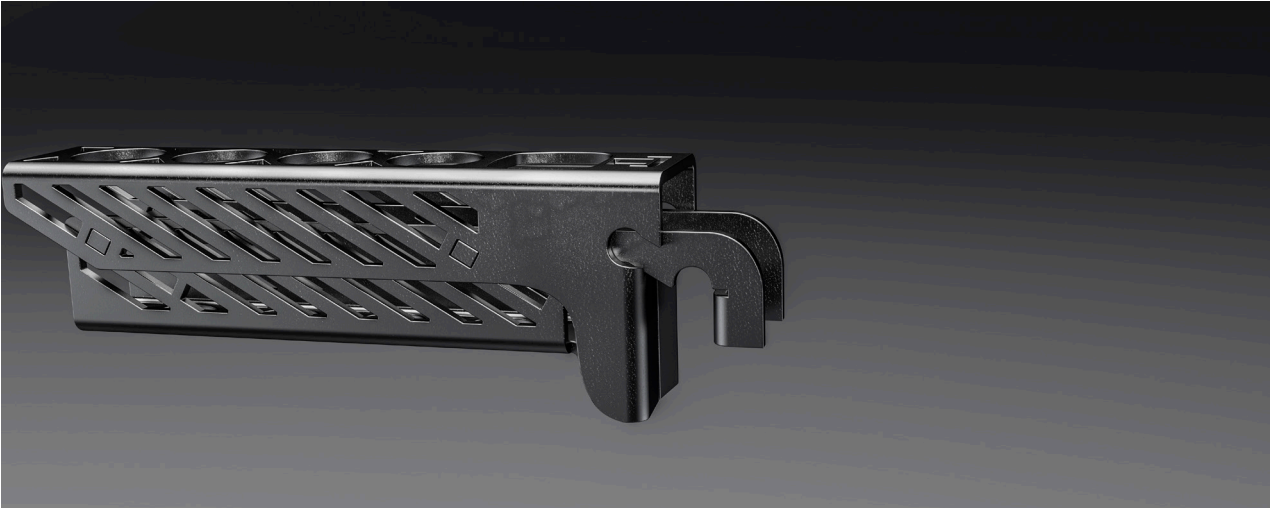

Figure 9.2 GlideLifter in open and closed position



Figure 9.3 GlideLifter seen from the front



Figure 9.4 GlideLifter getting attached to a pot while lifting

While hanging on the pot edge, the outer jaw's slanted upper contact surface serves to keep the handle in place. However, when lifting a pot, the small edge on the lower jaw will be raised into the gap between the rolled edge and the pot side. This assures a secure grip as gravity will make sure that the edge is kept in place; thereby preventing the jaw from sliding backwards and opening by mistake. Because of this, it is possible to lift the handle with virtually any grip and force without risking an accidental opening. See Figure 9.4.

Despite the increased height and extended surfaces GlideLifter only weighs 46 grams, the same weight as the current handle. This is achieved through the increased amount of holes are also designed to combat the effects of aluminium's high thermal conductivity. The stripes on the sides act as heat exchangers which reduces heat more efficiently than the old handle. Despite the increased number of holes, GlideLifter maintains a

high strength and is able to withstand rough handling.

The jaws of GlideLifter are large and smooth which allows pressure to be distributed on a much larger contact area than the old handle. The basic sliding principle acts to assure that the entirety of both contact surfaces reach the pot simultaneously, thereby preventing local pressure points. Moreover, as the handle does not open by itself when released the monotonous sliding and scratching associated with each opening of the old handle is reduced.

To further decrease the scratching, GlideLifter has an optional accessory in plastics that can be attached to the inner jaws. The protector fits perfectly over the two surfaces and is attached by bending the protector over the jaws and closed using a snap fit. It covers the two inner edges and removes any scratches created by them. Moreover, the softer ma-



Figure 9.5 The Plastic scratch protector open, closed and attached to the handle

material combined with smooth surfaces will more or less eliminate all scratching. Should the protector burn due to prolonged flame exposure, the handle will still be able to work as normal and the protector could simply be replaced with a spare. See Figure 9.5

GlideLifter is somewhat shorter than the current handle which makes it easier to fit in the stove. Despite this, GlideLifter is not experienced as shorter. By shortening the inner jaw, the gripping surfaces could be extended further than the current handle's gripping surfaces.

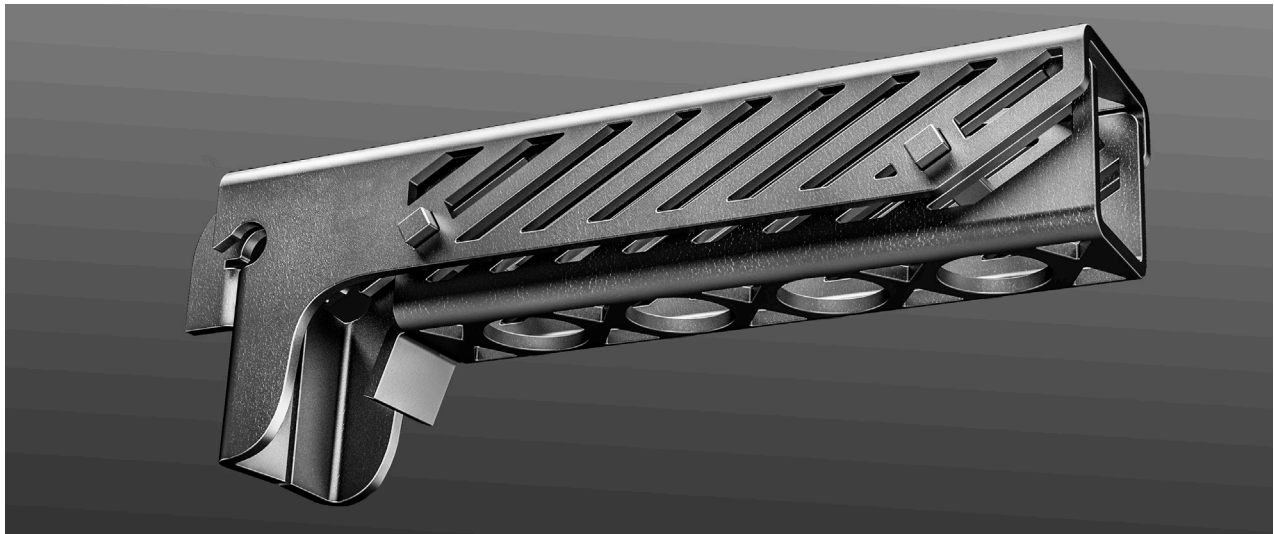

## BRANDING

GlideLifter has a slightly different expression compared to the old handle, but through the use of typical Trangia features it still manages to fit in with the product portfolio. The bending radii, flat gripping surfaces and circular holes have all been kept. These features in combination with the aluminium material strongly connects GlideLifter to the Trangia heritage. The logotype further solidifies the association with the Trangia brand. Furthermore, the strong focus on functionality allows GlideLifter to correspond to Trangia's core value of function over form.



Figure 9.6 The Handle from different angles



Approaching the pot



Prepare for gripping



Holding together to grab pot



Lifting the pot



Lifting with a very soft grip



Leaving the handle on the pot



Grabbing upper part to open



Removing the handle

Figure 9.7 Using Glidelifter

## 9.2 DEVELOPMENT

GlideLifter is different from Gripslide in some important aspects. The thumb rest was increased in size to provide increased support when opening and closing the handle. However, both the thumb rest as well as the other, smaller holes were removed from the bending areas as their previous placement decreased GlideLifter's strength considerably in force simulations. As the new thumb rest required more space, the logotype had to be reduced.

To increase the sliding function's guessability and reduce the heat conductivity, a series of angled holes were added to GlideLifter's sides. The front rail was moved further forward in front of the centre of gravity to facilitate automatic closure. By including a small edge that connects under the bent pot edge and by increasing the angle of the rail by 5°, GlideLifter has all but eliminated the risk of unintentionally opening the handle while lifting a pot or pan.

## 9.3 MECHANICAL PROPERTIES

If GlideLifter is left attached to a boiling pot, the temperature of the gripping surfaces will increase. However, by recreating the simulation from Chapter Five it was found that GlideLifter will experience a far lower temperature elevation than the current handle. After 120 seconds, most of the gripping surfaces will be kept at a safe temperature. 45°C will only be reached at very front, in surfaces close to the jaws, see Figure 9.8. When simulating the extreme case of frying an empty frying pan for 100 seconds GlideLifter reached a temperature of 35°C compared to 44°C for the old handle. Additional simulations showed that the fact that no holes extend across the bent edges increases the strength and robustness of the handle. GlideLifter can lift a pot weighing 10 kg without any deforming.

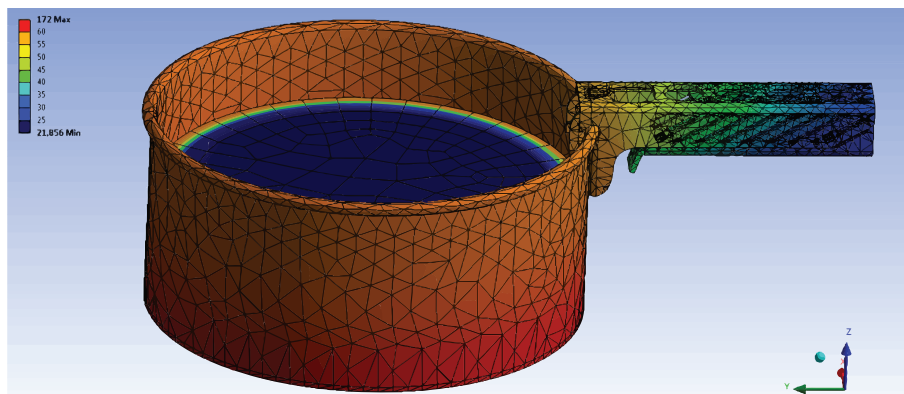

Figure 9.8 Simulation in Ansys of GlideLifter on a boiling pot

# 9.4 MANUFACTURING

GlideLifter will be possible to manufacture in Trangia's facilities by stamping and bending two millimetre thick aluminium sheet. While new dies would have to be made, the current machine park should be possible to use.

Using the Technical cost modelling as described by Ashby (2011) with values obtained from CES Edupack, an approximate production cost per product can be obtained. By using a capital write-off time of 5 years, a material cost of 20 SEK/kg and an overhead rate of 1300 SEK/hour; the cost for stamping will approach 4 SEK/unit for a total batch size of one million. As GlideLifter would be possible to produce for a significant amount of years, such a batch size is fully possible. When adding bending into the account the cost is likely to end at around 5 SEK per unit. See Figure 9.8.

The handle should be manufactured in an aluminium alloy less prone to get hot. This means that alloys with low thermal conductivity and a high specific heat capacity should

be sought. As the span in conductivity is much larger than heat capacity within the aluminium alloys, prioritizing low thermal conductivity yields better results. Aluminiums such as 5083, 5456, 6013 or 5086 are worth investigating further. All of these stand at a price around 20 SEK/kg. See Figure 9.9.

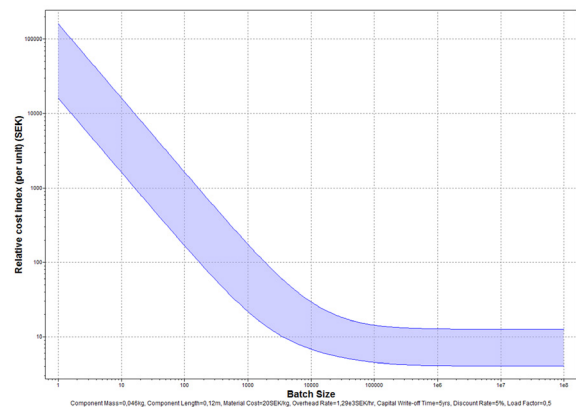

Figure 9.8 Cost modeling of GlideLifter

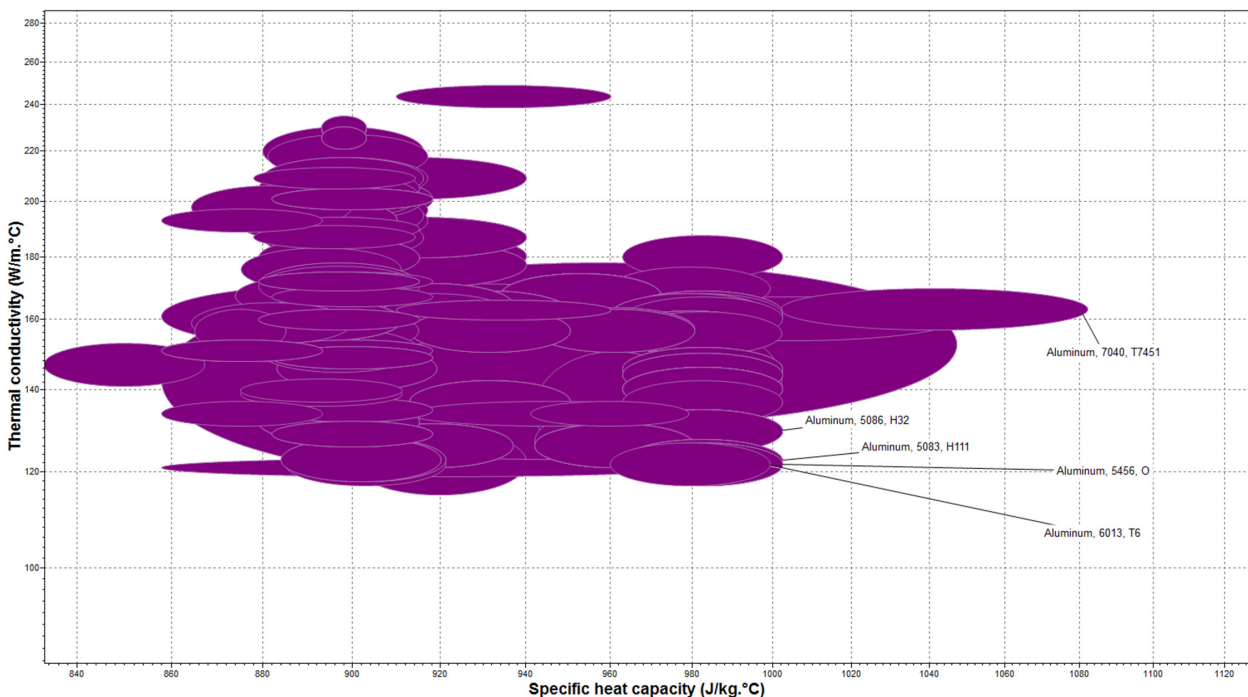

Figure 9.9 Aluminiums ranked by thermal conductivity and heat capacity

# 9.5 SUSTAINABILITY

The total environmental impact of GlideLifter can be calculated by making certain assumptions. In this case, an Eco audit concerning carbon dioxide emissions was made with CES EduPack. An Eco Audit is a type of Life Cycle Analysis, investigating the impact of all the steps in a product's life.

In this case, it is assumed that extruded and foil rolled Aluminium 5005 with a typical percentage of recycled material is used. That the material is transported 2250 km by rail, manufactured into a handle that is then transported 1000 km by 32 tonne truck. GlideLifter is then supposed to be used in Sweden for 25 years, transported with a diesel car for 20 days a year, each time covering 20 km. Finally, the material is assumed to be recycled.

This leads to total emissions of 0.4 kg of carbon dioxide, with a potential of 0.28 to be gained at the end of life if GlideLifter is recycled. The final carbon footprint will thus end at 0.12 kg. See Figure 9.10. The vast majority originates from the material phase and the rest mainly from being carried in a car during usage. This means that during 25 years of use, the handle's carbon emissions are comparable to an average new car taking a 1 km trip (Miljöbarometern, 2017).

While this analysis showed that manufacturing the handle from recycled aluminium will not affect the overall CO<sub>2</sub> impact, if the handle is recycled at the end of life, it is still

highly suggested to use recycled aluminium. Trangia cannot control what user may do with their handles, and unfortunately some users may not recycle their GlideLifter.

However, if the handle is manufactured out of 75% recycled aluminium, the immediate CO<sub>2</sub> emissions would decrease from 0.4 to 0.25 kg of carbon dioxide regardless of what the user may decide to do with their product. Furthermore, the analysis does not take into account other environmental issues, such as water pollution, caused by bauxite mining and refinement.

A stainless handle with the same stiffness per weight would weigh 71 grams. The total emissions for such a handle would be 0.19 kg of carbon dioxide compared to 0.12 for Aluminium. A PPS handle with the same stiffness would have to weigh 59 grams. Such a handle would instead lead to 0.5 kg emissions, mostly caused by the problems associated with recycling the material. Furthermore, a PPS handle would likely have a much shorter lifespan and therefore lead to a much larger value of emissions per year of use.

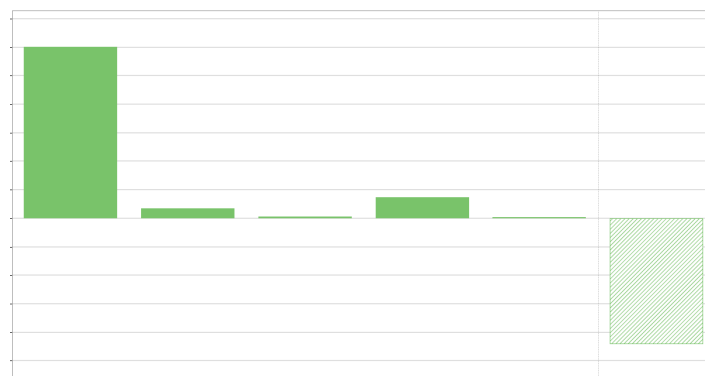

Figure 9.10 EcoAudit for GlideLifter. The bars show relative impact, from left, for material, manufacturing, transport, use, disposal and end-of-life.

## 9.6 EVALUATION

To assert the functionality of the new handle, the previously used focus group was consulted. The users were invited to try and test the handle, comment on how it worked and come up with ideas for improvements. In general, most users were satisfied with the new handle, with one user commenting that it was precisely the way to go forward. They appreciated GlideLifter's ability to safely grab and keep holding on to the pots and the sliding mechanism was said to work well.

However, a few of the users struggled with understanding the mechanism of the handle, indicating that it is unintuitive to use and understand for novice users. Furthermore, some of the users were concerned about how well the rail and rivets would sustain wear. The focus group provided ideas and feedback for further improvements of the handle which are summarised below.

## 9.7 NEXT STEP

There are some changes that could improve the functionality to become even better. To minimise possible wear from aluminium sliding against aluminium, the two sliding rods could be made in stainless steel. These could be shorter to minimise weight and wider to decrease the pressure on the rails. Attaching GlideLifter to the pots could be facilitated by preventing the lower jaws from sliding as far back as it currently does. This would enable users to almost always place the rounded cavity of the inner jaw at the right place on their first attempt. However, even if the user would place the handle in a wrong way, they should still be able to lift the handle. At this point, the shape of the jaws will need force to make sure that the handle slides into the correct position.

The triangular holes closest to the finger rest could be removed to reduce breakage when bending the part while the other holes could be placed even further from the edges to create a margin of safety. Moreover, GlideLifter should be coated in some kind of paint to make it less prone to temperature changes, stand out from its environment and reduce discomfort generated by sharp edges.



Figure 9.11 GlideLifter hanging on a pot.

# 10

## DISCUSSION

In this part, the important findings, decisions and aspects encountered throughout the project will be discussed. The discussions concern attached handles, plastics, sustainability, holes, multi-tool handles and requirement fulfilment.

# 10.1 ATTACHED HANDLES

The benefits and drawbacks of detachable handles have been discussed throughout the project. It was found early in the studies that, unlike Trangia, other brands have stove sets with fixed handles.

Attached handles were considered during the earliest stages of ideation, but were quickly discarded. Only ideas with semi-permanent handles were taken into consideration, but they were ultimately discarded as well. Despite this, there are some benefits to permanent handles. They never get lost, as they cannot be removed or fall off. They may have a lower weight as well, and they completely eliminate the scratching caused by detachable handles. However, they intrinsically make the stoves harder to pack, and less packing efficient. Their attachment to the pots will also lead to higher risks of severe temperature elevation, and each pot will need a handle of its own.

During the user study, some users complained about how permanent handles would obstruct them and be in the user's way as the user cooks and move about the camping site. Finally, most of the participants of the user study prefer detachable handles.

However, while permanently attached handles were found to be wrong for the Trangia 25 and 27 series, Trangia have other products that use permanent handles. These handles should be reviewed as competitors such as Primus Primetech and Optimus Terra have shown that foldable handles can be made quite space efficient and lightweight.

# 10.2 PLASTICS

It was found that no existing plastic material fulfils the needs and requirements of this project. This is unfortunate, as polymeric materials have several benefits.

A plastic handle could be made in more complex, organic shapes which could lead to a significant increase in comfort. They would cause less harm to the pot surfaces and would not cause the gripping surfaces to reach harmful temperatures within a reasonable amount of time. In all likelihood, a plastic handle would be lighter. It would be possible to make a handle in PPS plastics were it not for the adjustment of the spirit burner. PPS deforms after being held in a flame for 20 seconds, but can stand the temporary flames when hanging from a pot. This means that deformation is only likely to occur when adjusting the simmer ring. PPS plastic could therefore be an interesting option if the simmer ring could be adjusted without involving the handle. New plastics are constantly being developed.

Today, PEEK and PPS are the only temperature resistant plastics approved for use in contact with food, but in the future a new temperature resistant material may be developed that may even work with the simmer ring. However, the problem is that users tend to view plastic materials unfavourably. A plastic material has to overcome this scepticism.

However, Trangia should investigate replacing the material used in the plastic parts of the stove, such as the Multi-disc and kettle knob, with PPS. The plastic parts were often found to melt or deform when exposed to the flames. PPS would significantly reduce these issues. Furthermore, a PPS Multi-disc should be safe to use as a lid when boiling water which many users would appreciate.

# 10.3 SUSTAINABILITY & ETHICS

Virgin aluminium requires a massive amount of energy to be produced. It is commonly produced from strip mined bauxite ores. As one might imagine, strip mines have a huge effect on the ecosystem and local environment.

Thankfully, aluminium is an easy material to recycle, and requires only 5 % of the energy consumed by the production of virgin aluminium. As is shown in Chapter 10, using a higher percentage of recycled aluminium may not affect the overall CO<sub>2</sub> emissions if the handle is recycled. However, it reduces the short term CO<sub>2</sub> emissions and limits the other forms of environmental harm that occur during the material phase. The product uses basically the same amount of material as the current handle, and utilises the same production process. This means that the environmental impact will be very similar to the existing handle. Like the current handle, GlideLifter will be possible to use for years on

end which is good from a sustainability point of view. However, the inclusion of a plastic part on the jaws is problematic. However, this part will lead to less scratches on the non-stick coating, and thereby extends the life of the frying pan and other non-stick pots. As the frying pan contains a significant amount of PTFE, extending their lifespan should provide a significant environmental gain. When taking this into account, the plastic protector is highly justifiable. All of the handle, save for the plastic protector, is possible to manufacture at Trangia's facilities. This leads to a complete control of the production chain and the manufacturing process will take place in compliance with Swedish laws and regulations.

# 10.4 HOLES AND PATTERNS

The holes and patterns on the side of the product is not the optimal option for minimising weight or heat transfer. Larger holes would lead to a lower weight, while adding more and thinner stripes would have a rather significant effect on the heat distribution.

Neither is the upper gripping surface optimised for heat distribution. By replacing that pattern with thin stripes would reduce the temperature 6 degrees when the handle has a temperature around 40°C. Small, circular holes will reduce the temperature by up to 7°C. It would also be possible to cut out pieces from the transition surface between jaw and gripping surfaces. This leads to lower temperature but more instability. In the end, GlideLifter's patterns are based on a compromise between weight, temperature, aesthetics and branding. It was an ethical dilemma to choose between preventing burns or providing a lighter handle. As the handle is only a small part of the total weight of the stove, the prior could be considered more important. However, it was eventually decided to value weight over

temperature. Because of the closed and robust design of GlideLifter, users could perceive it as heavy. Even if the handle only weighs a gram or two more than the current handle, any increase in weight will severely affect the marketability of the product and deter customers. A pattern that allows GlideLifter to keep the same weight while slightly reducing the gripping surface's temperature elevation was therefore chosen. Furthermore, this decision allowed the pattern used for the upper and lower gripping surfaces to be used to express the brand heritage through the round holes. It should be noted that it is highly unlikely that an aluminium handle could ever be fully free from issues relating to the material's thermal properties. With that said, GlideLifter is a significant improvement over the current handle.

## 10.5 MULTI-TOOL HANDLES

During the user study, many users expressed interest in a handle with integrated functions such as can or beer openers, spatulas and knives. In the end, none of these suggestions are included in the final concept. There are a few reasons for this. First and foremost, a can or beer opener would need sharp edges and a stiffer material to work. It would not be possible to just stamp out a shape and expect it to work without obstructions. New manufacturing processes would be needed to chamfer the edges after stamping, and this would lead to additional costs. Moreover, these edges have to be easily accessible to be used, which induces a risk of getting hurt on the sharp edges. As a major quest in the design was to minimise harm and discomfort, multitools was not the way to go.

## 10.6 REQUIREMENT FULFILMENT

The extensive user study makes it highly unlikely that any major problems regarding the handle has been missed. Numerous minor issues were found over and over. This means that the requirement list is complete and covers the entire context surrounding the handle.

GlideLifter fulfils the requirements to a very high degree. It decreases scratching to an absolute minimum and makes it much safer to lift the pots. The handle will never fall off when lifting a pot and is still easy to remove when the pot is put down. The grip comfort is increased, pinching is eliminated and temperatures are decreased. The more robust design is likely to increase the trust in the handle, as is the fact that it does not fall off the pot edge.

It can grip all pots and windscreens. While some of the safety functions may not be applicable to duossal pots, they are also safer to lift with GlideLifter. The larger contact surfaces of the jaws make it easier to pick up the simmer ring as well. It can even pick up a frying pan that has been placed upside down. The only uncertainties regard long term use. Aluminium rods sliding against aluminium surfaces may cause significant wear. By replacing the rods with stainless steel, the lifetime will be increased. Furthermore, it has not been investigated how the handle responds to dishwashing, and how washing works overall.

# 11

## REFERENCES

In this Chapter, References to all used sources will be listed.

# 11.1 REFERENCE LIST

Ahlins. (2017). Hårdanodiserat håller för de tuffaste miljöerna - Ahlins. [online] Available at: <http://www.ahlins.com/nyheter/hardanodiserat-haller-for-de-tuffaste-miljoerna/> [Accessed 2 May 2017].

Ashby, M. (2011). *Material selection in mechanical design*. 1st ed. Amsterdam: Butterworth-Heinemann.

Britannica Academic. (2017). Moh's hardness. [online] Available at: <http://academic.eb.com/levels/collegiate/article/Mohs-hardness/53205> [Accessed 25 Apr. 2017].

British Plastics Federation. (2017). Polyphenylene Sulphide PPS. [online] Available at: <http://www.bpf.co.uk/Plastipedia/Polymers/PPS.aspx> [Accessed 25 Apr. 2017].

Burn Foundation (2017). Scald Burns. [online] Available at: <http://www.burn-foundation.org/programs/resource.cfm?c=1&a=3> [Accessed 17 May 2017].

Cambridge Engineering Selector. (2017). Cambridge: Granta Design.

Campbell, T., Kalia, R., Nakano, A., Vashishta, P., Ogata, S. and Rodgers, S. (1999). Dynamics of Oxidation of Aluminum Nanoclusters using Variable Charge Molecular-Dynamics Simulations on Parallel Computers. *Physical Review Letters*, 82(24), pp.4866-4869.

Coastline Metal Finishing. (2017). Hard Anodizing. [online] Available at: <http://www.coastlinemetalfinishing.com/anodizing/hard-anodizing> [Accessed 2 May 2017].

Custers, E. (2015). Reflex Action and Reflex Arc: What Happens When You Accidentally Touch a Hot Pot. [online] Owlcation. Available at: <https://owlcation.com/stem/Here-is-what-happens-when-you-accidentally-touch-a-hot-pot> [Accessed 25 Apr. 2017].

Dielectric Corporation (2017). Teflon® (Polytetrafluoroethylene, PTFE). [online] Menomonee Falls: Dielectric Corporation. Available at: <http://www.dielectriccorp.com/downloads/thermoplastics/teflon.pdf> [Accessed 25 Apr. 2017].

Dupont Kapton: Summary of properties. (2017). Wilmington: Dupont. Available at: <http://www.dupont.com/content/dam/dupont/products-and-services/membranes-and-films/polyimide-films/documents/DEC-Kapton-summary-of-properties.pdf> [Accessed 25 Apr. 2017].

Elvers, B. and Ullmann, F. (2016). Ullmann's polymers and plastics. 1st ed. Weinheim: Wiley-VCH Verlag GmbH & Co. KGaA.

Foster. (2017). High Performance Polymers. [online] Available at: <http://www.fostercomp.com/products/high-performance-polymers> [Accessed 25 Apr. 2017].

Huo, Z., Ratulowski, J. and Yang, W. (2010). Non-stick cookware. US20100276432 A1.

Material Safety Data Sheet: Duratron. (2017) (1st ed.). Fairmont Avenue. Retrieved from [http://www.alro.com/datapdf/plastics/plasticsmsds/msds\\_ul-tempei.pdf](http://www.alro.com/datapdf/plastics/plasticsmsds/msds_ul-tempei.pdf)

Material Safety Data Sheet: Hi-Shrink Tape. (2017) (1st ed.). Charlotte. Retrieved from <http://www.shrinktape.com/assets/ce/Documents/MSDS/Hi-Shrink-Polyimide-MSDS-Rev1.pdf>

Material Safety Data Sheet: Polyester-Thermoplastic Resin. (2005) (1st ed.). Cornelius. Retrieved from [https://wcam.engr.wisc.edu/Public/Safety/MSDS/Polyethylene%20Terephthalate%20\(PET\).pdf](https://wcam.engr.wisc.edu/Public/Safety/MSDS/Polyethylene%20Terephthalate%20(PET).pdf)

Material Safety Data Sheet: Stanyl. (2017) (1st ed.). Overland Park. Retrieved from <http://catalog.ides.com/WebFileShare/ClientDocs/CPA/Stanyl%20TE373.pdf>

Material Safety Data Sheet: Thermx. (2010) (1st ed.). Florence. Retrieved from [http://www.swpnc.co.kr/index/downloadfile/PCT\(THERMX\)/THERMX%20CG933/MSDS/BK010%20BLACK.pdf](http://www.swpnc.co.kr/index/downloadfile/PCT(THERMX)/THERMX%20CG933/MSDS/BK010%20BLACK.pdf)

Material Safety Sheet: Torlon. (2017) (1st ed.). Retrieved from <http://kr.rs-online.com/webdocs/01e8/0900766b801e8907.pdf>

Miljöbarometern. (2017). Personbilar. [online] Available at: <http://2030.miljobarometern.se/nationella-indikatorer/bilen/genomsnittliga-koldioxidutslapp-hos-nya-fordon-b1h/personbilar/> [Accessed 30 May 2017].

Miltonplastics. (2017). POLYPHENYLENE SULFIDE (PPS)-PLASTICS MATERIALS INTRODUCTION. [online] Available at: <http://www.miltonplastics.com/index.php/Picture/show/8.html> [Accessed 25 Apr. 2017].

NASA (2010). A New Approach to Defining Human Touch Temperature Standards. Houston: NASA/Johnson Space Center Houston, TX 77062.

Parsons, K. (2014). Human thermal environments. 1st ed. Boca Raton, Fla. [u.a.]: CRC Press/Taylor & Francis.

Paul, J. (1980). Methanol technology and application in motor fuels. 1st ed. Park Ridge, N.J.: Noyes Data Corporation.

Physics world. (2017). Absorption and emission of radiation. [online] Available at: [http://www.hk-phy.org/contextual/heat/hea/radia02\\_e.html](http://www.hk-phy.org/contextual/heat/hea/radia02_e.html) [Accessed 2 May 2017].

Platt, D. (2003). Engineering and High Performance Plastics Market Report: A Rapra Market Report. 1st ed. Shrewsbury: Rapra Technology Ltd.

Polyimides. (2017). Billerica: Epotek. Available at: [http://www.epotek.com/site/files/Techtips/pdfs/Tech\\_Tip\\_27\\_-\\_Polyimides.pdf](http://www.epotek.com/site/files/Techtips/pdfs/Tech_Tip_27_-_Polyimides.pdf) [Accessed 25 Apr. 2017].

PPS Resin: Material Safety Data Sheet. (2009). Hong Kong: Kotec. Available at: [http://www.kotec.com.hk/pdf/pps/1340l\\_mads.pdf](http://www.kotec.com.hk/pdf/pps/1340l_mads.pdf) [Accessed 25 Apr. 2017].

Safety Data Sheet: Polybutylene Terephthalate (PBT). (2008) (1st ed.). Jubail Industrial City. Retrieved from [http://www.sipchem.com/portals/0/Module-Content/Brochure/Files/products/polymers/PBT-SDS-rev3-05\\_2015.pdf](http://www.sipchem.com/portals/0/Module-Content/Brochure/Files/products/polymers/PBT-SDS-rev3-05_2015.pdf)

Saxena, P. and Williams, F. (2007). Numerical and experimental studies of ethanol flames. Proceedings of the Combustion Institute, 31 (1), pp.1149-1156.

Solvay. (2017). Ryton® PPS - Health, Safety & Environment | Solvay. [online] Available at: <http://www.solvay.com/en/markets-and-products/featured-products/Ryton-Health-Safety-Environment.html> [Accessed 25 Apr. 2017].

Stachowiak, G. (2005). *Wear: Materials, Mechanisms and Practice*. 1st ed. Wiley.

Stanyl® ForTii™ F11 (NC1101A). (2017) (1st ed.). Heerlen. Retrieved from [http://www.hdconn.com.tw/extfile/003/001/dsm\\_nc1101a.pdf](http://www.hdconn.com.tw/extfile/003/001/dsm_nc1101a.pdf)

Straffelini, G. (2015). *Friction and wear: Methodologies for Design and Control*. 1st ed. Cham [etc.]: Springer.

Ulrich, K. and Eppinger, S. (2011). *Product design and development*. 5th ed. New York: McGraw-Hill/Irwin.

van Beek, A. (2009). *Advanced engineering design*. 1st ed. [Delft, The Netherlands]: TU Delft.

What does color have to do with cooling?. (2017) (1st ed.). Colorado. Available at: <http://littleshop.physics.colostate.edu/activities/atmos1/ColorAnd-Cooling.pdf> [Accessed 25 Apr. 2017].





# APPENDICES

In this Chapter, all the Appendices referred to in the text are found.

# APPENDIX 1.

## STATISTICS FROM THE QUESTIONNAIRE

### Hur ofta använder du ditt Trangiakök?

394 svar

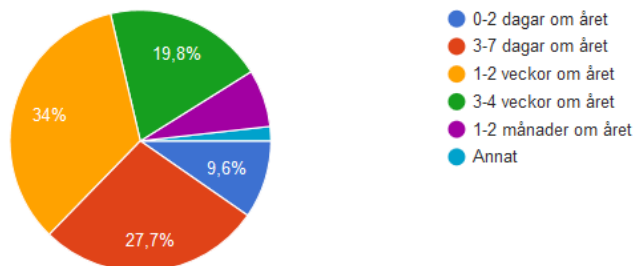

### Hur nöjd är du med ditt Trangiakök?

394 svar

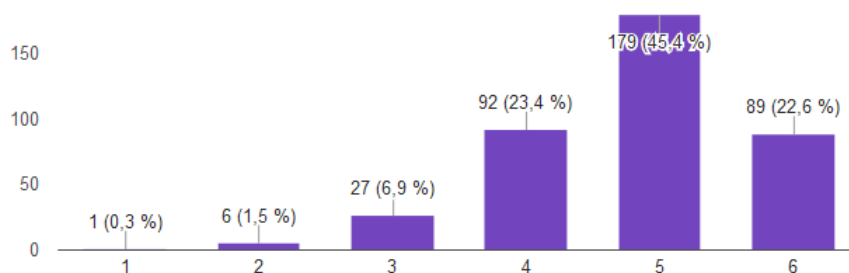

### Vilken typ av bränsle använder du?

394 svar

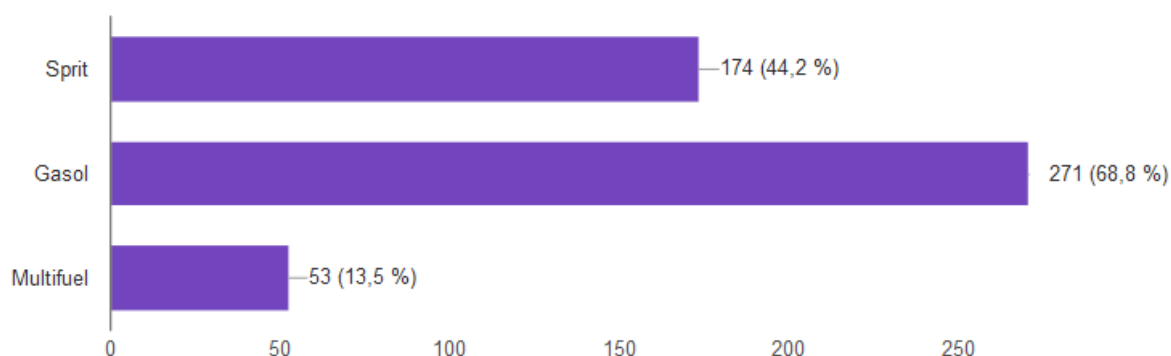

## Använder du något annat kök än Trangia?

394 svar

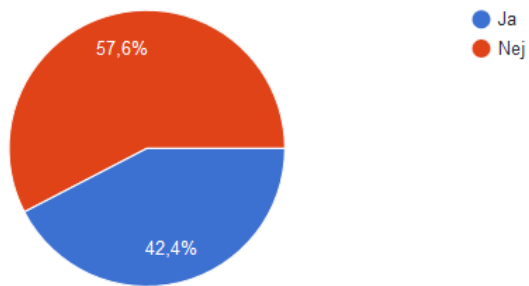

## Har du kaffepanna till ditt Trangiakök?

394 svar

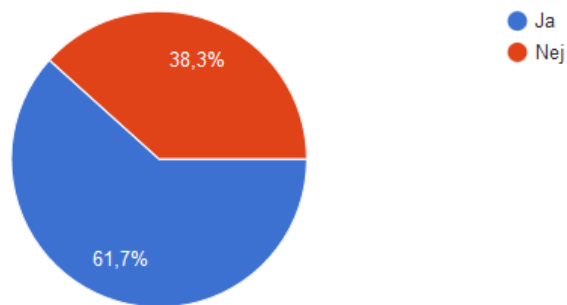

## Har någon av delarna i ditt Trangiakök non-stick beläggning?

394 svar

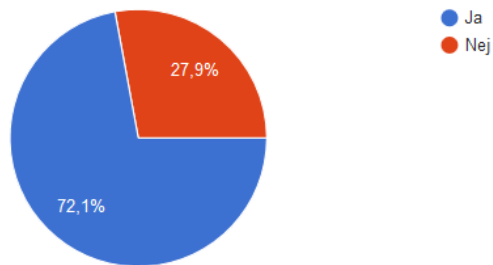

## Vilken/vilka delar har non-stick beläggning?

284 svar

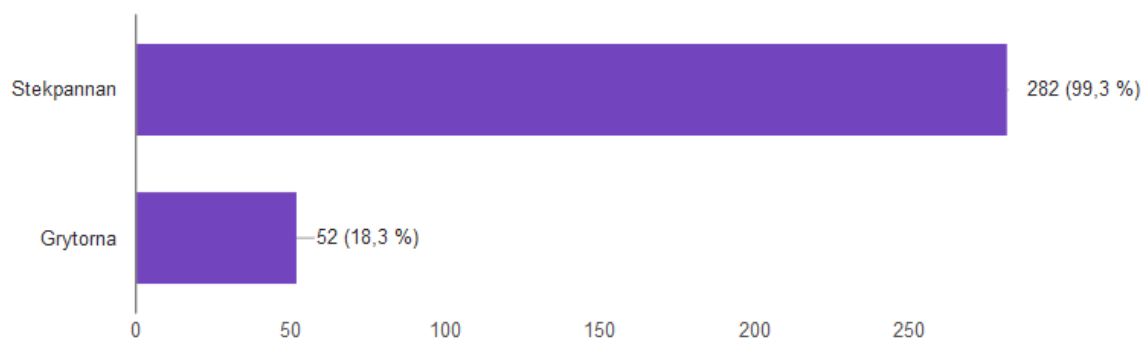

## Hur lätt upplever du att non-stick beläggningen är att repa?

284 svar

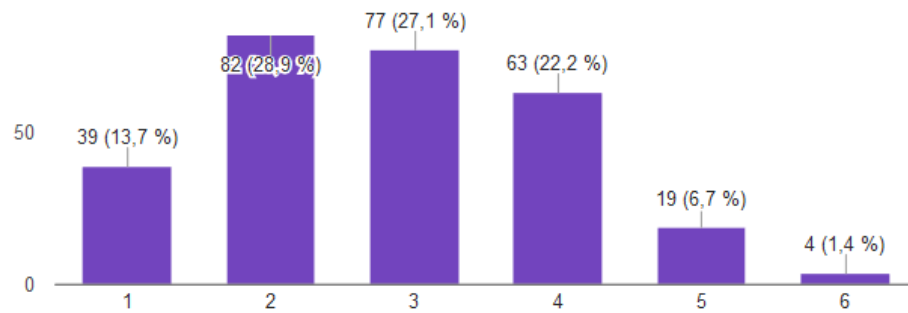

## Har du kvar plastskyddet som följde med stekpannan?

284 svar

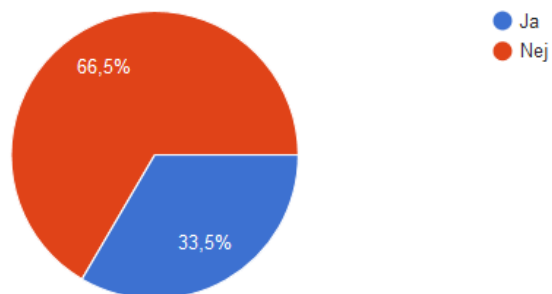

## Hur lätt upplever du att ditt Trangiakök är att förvara i din packning?

394 svar

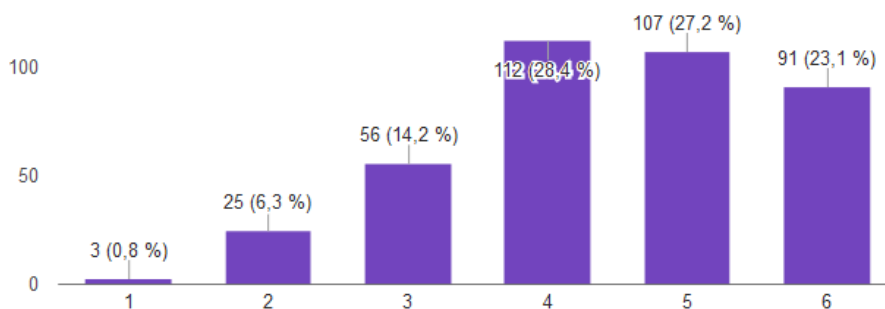

## Hur väl tycker du att handtaget fungerar?

394 svar

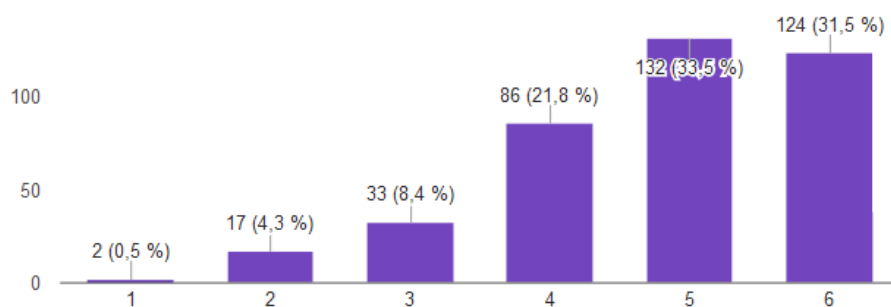

## Hur bekvämt tycker du att handtaget är att greppa

394 svar

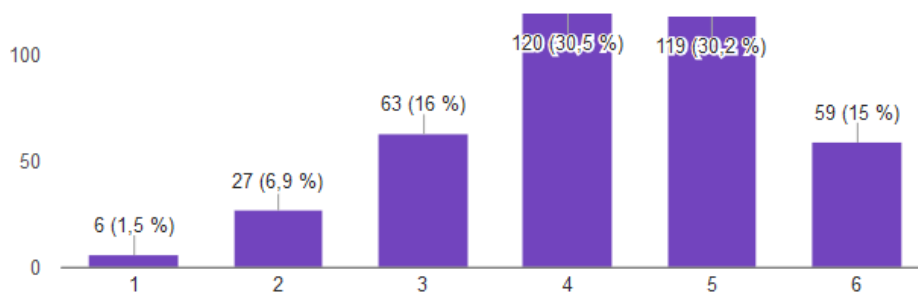

## Brukar du låta handtaget sitta kvar på kärnen när du lagar mat?

394 svar

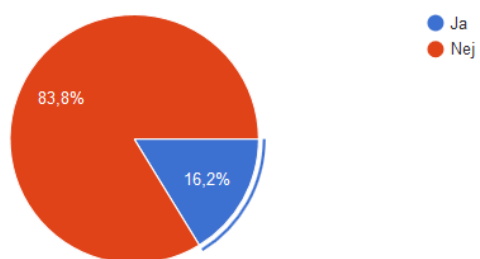

## Har du upplevt några problem med handtaget?

394 svar

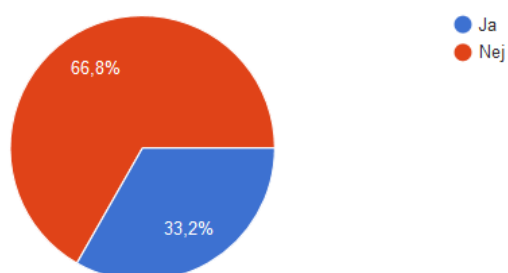

# APPENDIX 2.

## USER STUDY INTERVIEW GUIDE

### INLEDANDE FRÅGOR

1. Vad har du för stormkök?
2. När använder du det?
3. Hur mycket erfarenhet har du av att använda det?
4. Om du har flera stormkök, vad är skillnaden? Vilket föredrar du?
5. Hur förvarar du ditt kök?

### TEST

1. Packa upp produkten
2. Koka vatten
3. Ta av kastrull
4. Byt till stekpanneläge
5. Diska och packa ihop

### AVSLUTANDE FRÅGOR

1. Hur gick det?
2. Var det något som var svårt?
3. Vad hade kunnat förbättras?
4. Vad tycker du om köket överlag?
5. Vad skulle kunna bli bättre?
6. Vad tycker du om handtaget?  
Hur känns den att hålla? Hur känns hålen och undersidan?  
Har du upplevt att handtaget trillar av eller inte fungerar?  
Har du upplevt att handtaget skadar beläggningsen på kärnen?  
Har du bränt eller skadat dig på handtaget?
7. Vad skulle kunna förbättras?  
Finns det någon funktion du skulle vilja ha?
8. Vilka egenskaper tycker du är viktigast?

### FÖLJDFRÅGOR FÖR HANDTAGET

1. Vad är bra med handtaget?
2. Använder du handtaget till något annat än att hålla kärl?
3. Har du någonsin skurit dig på den?
4. Känner du att kastrullerna är stabila när du lyfter?
5. Öppnar sig handtaget någon gång av misstag?
6. Hur förvarar du handtaget när du inte använder det?
7. Använder du vantar när du handskas med handtaget? Är det isf något problem?
8. Hur tycker du att handtaget ser ut?
9. Har du testat något annat stormkökshandtag?

# APPENDIX 3.

## USER STUDIES DETAILED RESULTS

The user studies included a free-text questionnaire with 394 respondents, 21 telephone interviews, 46 mail interviews and 15 user tests with 35 participants. Users were from age 16 to over 70, and using the stoves in both nature, camping, indoors and festivals. Comments were sorted with the KJ-method and summaries below, in addition to two requirement lists.

### GENERAL REMARKS

Users are generally pleased with their stoves, rating them on average as 4.8 on a scale from 1 to 6. There is a significant correlation between not using other stoves and being more positive, but not between how often the stoves are used.

Dissatisfied users generally comment on weight and size, soot as well as efficiency, and in one case hardness to ignite in winds. Using spirits is significantly correlating with being more displeased, and using gas is significantly correlating with being more pleased. This is a strong indication to improve the spirit burner or promote gas more.

The general opinion is that Trangia is durable and reliable, much more stable than gas canister-mounted stoves, and enabling real cooking outdoors. One user meant that Trangia is the only kitchen working in a mountaintop blizzard at  $-40^{\circ}\text{C}$ . The versatility in fuel sources and use situations as well as storage possibilities is highly praised. When getting dented, the stoves are easy to repair. Regarding aesthetics, the stoves got rather mixed opinions.

### MARKETING

The product names are seen as confusing, with users not understanding the many variants or that 27 is smaller than 25. Some users suggest names relating to functions or customer groups instead. The wide assortment of spare parts is highly appreciated, and some even want to pick and mix their own combinations from the beginning.

It is often mentioned that Trangia is invisible due not not existing in social media or having other campaigns. The classic stoves are very well known to most people in Sweden, but other products are only spread in certain outdoor communities. This leads to users asking for specific products that Trangia already offer, as the Multi-disc and 5-litre pot. A more active website with better information and all products as well as a Facebook page for communication with users is often asked for.

### THE BURNERS AND FUELS

Gas is the most commonly used fuel, used by 69% of the respondents, followed by spirits on 44% and multifuel on 14%. The proportion using spirits has gone down significantly, and those having made the switch acknowledge that they will not go back.

The spirit burner is seen as very good for its kind, but rather heavy. Many users only use it due to possessing it rather than having made an active choice to get one. Some use it during cold winters or for nostalgia reasons. Users commonly store spirits in it, and do not want it to leak. It is regarded paradoxical that there is a gasket in it, when recommendations are to not store spirits in it. Gaskets commonly break, and can fall out of the lid, getting burnt up when using the burner. Many users keep the plastic container bag until it breaks or melts, but other see it as a strange solution hard to place when using the burner. Users use it to stop the burner from leaking, but often ask for other types of bags. It is often twisted when closing it, leading to wear. Few users read the information, but the colour combination is liked as it indicates danger and warmth.

Spirits are generally seen as problematic. The main issues are the soot formation, the messiness when pouring liquid fuel, the cooking time as well as leaking spirits destroying the food. Moreover, possible hazards from large flames or fires when spilling is widely

mentioned, as are the risks of pouring it out in nature. On the positive side is the quietness, although this makes it hard for users to know if or when it is burning. Another benefit to using spirits is that it is easy to modify the amount of fuel to bring and to know the exact amounts of fuel remaining. However, users find it hard to determine how much fuel to use in the burner, and the cooldown period required to safely refill the burner is seen as a major disadvantage. This has led to some users bringing two burners, or more commonly: that they use an excessive amount of fuel. Some also do not know how much to fill it, and want a scale as well as an indication of max filling.

The submersion on the top is sometimes used as winter starter with spirits poured on it, as many find the winter attachment messy. Interestingly, irregular users do not know how to ignite it, and gas users might try lighting it at the holes on the upper side. Igniting it in wind without windscreen is hard, and it is regarded awkward to do it within the windscreen. Users have a hard time knowing whether it is burning, and it is seen as messy to put the fire out on the inside of the stove, instead of the colder outside. It is common to just burn all fuel. When being used, the holes becomes cluttered with soot.

The simmer ring is overwhelmingly disliked. The brown lid is regarded as almost impossible to adjust when placed on the burner, and the entire ring rotates when pushed. Many users get frustrated, and some try to remove it and press it to the ground to adjust it. The fact that the pot needs to be removed to allow the heat to be adjusted also regarded as problematic. Many users therefore never use the ring, and instead adjust heat by lifting their pots up and down. Those using it often find that it leads flames to the sides, giving uneven heat. Many find it hard to know how much it changes the effect, and want a scale on it. The simmer ring also makes it harder to ignite the burner and is more frequently often used to put the fire out, something that cannot really be done if it is used to

simmer. Throwing the lid or simmer ring to quell the flames requires some precision, which can be hard for some users, especially if the lid misses.

The gas burner appreciated, and the most common issue is users wanting piezo-igniters that are better than Primus easily broken ones. The burner corrodes over time, especially when used in environments where it may become exposed to salt water. It may also break in the attachment. Both when mounting and putting together, the hose is seen as too rigid, as well as too short to reach gas canisters comfortably. Indeed, stoves have rolled over due to tipped gas canisters. The hose is hard to pull through the hole in the windshield, and the larger burner is hard to place within stoves. When using it, the sound volume is regarded high, and many want better gas regulation and possibilities to have gas canisters upside down, or even beneath the windscreen.

The existence of a multi-fuel burner is liked, but it is seen as hard to adjust, put together and store in the kitchen, and many question why it cannot be used for gas. When using it, the sound level is so high that users buy quiet stoves for it. At the same time it makes parts of the stove very warm. Users generally want burners that they can trust, which they normally do. Certain users want other fuels for Trangias, as firewood, meta-tablets or candy heaters, and some indeed does burn firewood under the stoves today. Interestingly, some bring another burner to keep food warm or cook two meals simultaneously.

## MATERIALS

A significant share of users have issues with the non-stick coating, describing it to be less durable and much easier to scratch than competing brands. The resistance against scratching is rated 2.8 on average on a scale from 1 to 6, where 1 means very easy to scratch. Only a third keep the plastic protector, although some use the Multi-disc. It is strongly suggested that Trangia shall investigate the issue and find a replacement, as 72%

of users are found to have a non-stick pan and 13% a non-stick pot. Users want to have some non-stick as it facilitates cleaning and cooking.

A common request is other materials, such as ceramic coatings, stainless, duossal, titanium and even cast iron. Steel, duossal and cast-iron are however seen as heavy, and lightweight materials such as titanium can be hard to fry or cook in. There are also requests for material that better preserve heat, as well as not transporting heat away from the windscreen in windy conditions. Some concerns regarding aluminium were also raised, such as it being easy to dent, getting cold to touch in winter, not good with sour ingredients, and some are worried about aluminium getting into their food. There have also been instances of pots breaking due to saltwater corrosion or burns.

#### Use context and Trangia setup

Users in different contexts have different demands. For those mountain hiking, weight is important, especially when going solo. For kayakers, size matters more than weight, and campers mind none of these. However, functionality is always prioritised highest.

The kit is highly appreciated as a complete setup for cooking that fits well together. Most users never modify their kits, and thus rely on prepackaged kits. But those that do find that the kit tends to rattle when parts have been removed. A general issue is the lack of flexibility in pot sizes, especially that 25 pots cannot be used on the 27 and vice versa. Furthermore, some users would have preferred a larger kit, containing two burners so that two pots can be used at the same time, while others want a smaller kit that can fit inside the side pocket of the backpack.

Users bring items along in the kitchen, most commonly the Multi-disc, but also cleaning utensils, igniters, spices, cooking utensils, can openers, cutting boards or plastic bowls. The possibility to do so is highly regarded, but users ask for reasonably size gas canis-

ters that can be stored in the stove without sliding.

## MOUNTING AND PACKING

The kit is regarded easy to mount and pack, but to facilitate the learning process for new users, visual instructions were requested. Users rated the easiness of packing as 5.2 on a scale from 1 to 6. Incidents where users confuse the windscreen assembly or pack pots upside down are noted. Some users facilitate the assembly of the windscreen by marking the attachment points. The pot holders are in the way when packing due to falling down on pots, causing frustration. It is regarded particularly hard to pack items in the kettle, especially the handle and gas burner.

The stove is seen as fairly easy to store during trips, on average 4.4 on a scale from 1 to 6. Many users find it compact compared to the content, but many others find it large and heavy and ask for more compact or lightweight versions. Spirit users find their stove harder to store without using a cover, due to concerns regarding soot. A common complaint is that the stove rattles when hiking or cycling, and many try reducing it with paper or cloths. The 27 is said to rattle more than 25 due to larger gap between parts, and mini rattles the least. Both handle, kettle lid and pot holders contribute to rattling.

## THE WINDSCREEN

The windscreen is highly regarded, and often mentioned as Trangias main advantage. It is seen as stable and protects the pots well from wind. One user had conducted some tests to investigate the effect of the windscreen in terms of fuel saving and found that he saved 10 grams of gas per litre water by using the windscreen. The users though this benefit should be promoted more by Trangia, especially as some users consider the windscreen to be unnecessarily heavy and that it makes the Trangia stove feel larger than it ought.

The windscreens were found to be quite easy to assemble and the bayonet mounting is an appreciated feature. The upper windscreen was usually mounted first, and demounted when igniting the burner. The lower windscreen is questioned by certain users, finding it large or heavy. Interestingly, users disregard the wind direction when placing the windscreen, and some want increased ability to place it on uneven terrain. Many users find it hard to pull the gas hose through the hole, and many have even drilled own holes through it. The top surface tends to deform over time, making the mounting of the burner harder. The windscreen was also found to harm the frying pan when packed together, and could become warm during cooking.

## THE POT HOLDERS

A common concern with the pot holders is the heat loss when frying or using the large pot, due to cold air gushing between the windscreen and the pan, leading to significantly longer frying times. The windscreen is regarded by some as useless when frying, and many users thus avoid using the frying pan. Others drill holes in the windscreen top to allow them to place the pan there without putting the burner out, or manually hold the pan during frying, rendering the handle hot. One user had incidentally bought a 27 frying pan for a 25 windscreen due to assuming it had a larger diameter, leading to the discovery that this frying pan was small enough to place within the windscreen and use.

Switching to frying mode is regarded as unpleasant, especially if the burner is lit. Gas users would even turn off their gas to avoid burns. Most users use the handle for this, but some need two to also hold the windscreen. The holders are hard to clean, annoying when packing the stove, and found to scratch the frying pan when the stove is packed. Pot holders are also found to be unstable, especially with frying pan of kettles, falling over or getting tilted. This makes it hard to stir food without using the handle. Kettles are too small to stand stable, especially on old bent holders. Some users

thus ask for four or more holders, or new mechanisms such as placing pots directly on the burner.

### The pots and pans

The pots are generally well liked, but requests for food spouts or heat exchangers exist. Some are however concerned with carbon monoxide or getting stuck in heat exchangers. A recurring complaint regards the volume markings, as the placement on the outside is unintuitive and a more detailed scale could eliminate needs for measuring cups. Pots are sometimes placed in a fire to keep warm, but it is regarded hard to grab without risking burns. Moreover, the pots are sometimes regarded as slippery when used on non-Trangia burners.

Despite provided instructions, many users place the frying pan upside down when used as a lid, due to it enclosing the heat, not falling off, or to avoid seagulls picking it up. It is also a way to avoid soot and dirt to fall from the underside of the pan and into the pot. This action makes it harder to use with the handle. Some place it with the right side up, to keep food warm or avoiding spirit fumes contaminating the pot. As previously mentioned, a significant number of users use the pan solely as lid and find it too heavy and large compared to other lids. Certain users ask for other lids that can keep both pots warm, and that the lids should work with the handle attached to the pot.

62% of the users own a kettle. Many regard it as essential, but others see it as heavy and optional. The kettle is more frequently used over fire than the pots. The plastic cover is however seldom removed and therefore often melts. The kettle lid rattles during transport, and some users regard the kettle as too high to fit perfectly with the pots. It is also regarded as hard to clean due to the spout and general shape as it is hard to completely empty the kettle of liquid. Some users want to replace the kettle with a french press lid, while others would want a tea insertion for the kettle.

## THE HANDLE

Users generally regard the handle as rather positive, on average 4.8 on a scale from 1 to 6. The gripability is seen as fairly good, on average 4.2. It is found that 84% do not leave the handle on the pots when cooking. Furthermore, users indicate that the handle can be difficult for children to use. It is widely noted that the handle scratch or deform the pots. While this mainly affect non-stick, other materials have been known to be harmed as well. This can happen both when the handle is actively used, also when the handle is packed into the kitchen as it may move around during transportation .

Users often ask for handles in other materials, most often to make it smoother to grasp, not being cold in wintertime or warm hanging on the pots, or to minimise scratching. Some users have even covered their handles in other coatings on their own. An interesting notion is that Primus handles have small plastic blobs to prevent scratching, that some users mean fall off after a few days of usage. Opinions regarding aesthetics are mixed, although most users do not really mind the looks at all, regarding it as a purely functional object.

The handle has also been known to harm users as it has frequently been described as having caused burns when left hanging on a pot. While most users rarely repeat that mistake, avoiding burns is crucial. Others have also gotten pinched by the handle when gripping objects, sometimes leading to bloodshed. There were mentions of how sometimes the pots may waggle in the handle while pouring water, causing users to get afraid and drop the objects. This leads to food falling out, and may cause burns.

Although it received a fairly high rating, many users express complaints regarding the ergonomics. Generally, those holding it for short times tend not to care, but users who hold the pots for longer durations while stirring or heating are more concerned with ergonomics and comfort. The sharp edges

on the lower side of the handle is seen as a major contributor to poor ergonomics, something that is even more apparent on newer handles. Due to not trusting the handles holding abilities, many users feel an urge to hold it more convulsively, leading to increased discomfort. The vast majority find the size comfortable, although some find it too small for their hands. The size is more commonly referred to regarding packing. Certain users also believe it to be too heavy, even modifying it to get it lighter. Furthermore, some considered it difficult to maintain a grip of the handle when opening it, or had trouble maneuvering the handle without accidentally closing it prematurely.

The handle has a tendency to become very cold during chilly conditions, and is considered to be somewhat difficult to use while wearing gloves. Users have experienced that the gloves have gotten stuck in the handle, or that the gloves impair their fine motor skills thereby making it hard for them to use the handle. Furthermore, the handle was found to sometimes become frozen shut in colder environments. The handle could also get stuck as a result of prolonged use.

All users use the handle to grab pots and frying pans, and most use it to fold the pot holders when cooking. It is commonly used to move or rotate the stove by grabbing the upper windscreen, as well as to demount the stove when warm. It is commonly used to grab or adjust the simmer ring, but this works insufficient due to a very bad grip. Many users use it when eating from pots, or grab other dishes and mugs. Moreover, it is used for a multitude of other uses, such as stirring food or breaking branches.

The handle is seen as providing a good grip, but there are difficulties when gripping pots with curved edges, such as the duossal pots, using more worn handles. The handles tend to lose their grip with age, and may begin to slide sideways on the pots. Prolonged use on heavy pots also lead to the shanks getting bent. Many users express having lost their grip, and feel that the handles are unstable

as a result of this. While this is often a result of the misuse by the user, there are instances such as when a user wishes to hand a pot over to another person where it is very easy for the handle to accidentally open. Thus, some users regard the handle as unsafe and unstable which cause them to use a much firmer than needed. Some blame the shape, with the lower gripping part covered by the upper, as making it harder to get a good grip. Users are generally more afraid of handle opening than it actually happening

A common problem with the handle is that it tends to get temporarily lost. As the users are required to detach the handle from the pots, they leave the handle in other areas of the camping area while executing other tasks and then forget where they put the it. Many users also wish to avoid having to place the handle on the dirty ground, and try to find other placements. Some users even bring two handles in case one disappears. Others tie it to their stoves or paint it in bright colours to enable it to be easily located. It is also noted that the handle has no natural placement in the packed stove. It is hard to fit into the kettle, it does not fit above it, and it causes noise and damages the non-stick when not packed tight. Furthermore, the handle is regarded as hard to clean, due to the holes and hidden surfaces. Some users wash them in dishwashers, leading to it becoming harsh or stuck in the locked position.

To counteract some of the problems that they have experienced with the handle, several users want to be able to lock the handle on to the pots, thereby securing a tight grip. However, such a lock must be easy to open, and must not malfunction. Others ask for self-opening handle, so that they may avoid getting the handle stuck. There are also those asking for other integrated functions, such as can openers, cleaning needles for burners, spatulas, or even turning the handle into a multitool. There is a common discussion whether fixed or loose handles are optimal. Many users prefer loose due to the storage benefits, the handle not getting in the way,

replaceability, and heat purposes. Some prefer fixed, due to them not getting lost and possibly being lighter.

The handle is generally seen as superior to the mini handle, that some users bought believing it to be a new version of the handle. Overall, most users find the handle to be working well, but some see it as the least good thing with Trangia. Despite this, many users use their Trangia handle if they have pots from a competing brand as they believe the handle to be superior the competitors.

## CLEANING

Most users do clean their stoves outdoors. During day excursions, less thorough rinsing is common, with proper cleaning taking place indoors. Some use dishwashers, leading to dull surfaces and sluggish handles. Longer trips usually demand more thorough washing in the field.

Some users eat out of the pots to avoid cleaning. Some of them use metal cutlery that scratch the pot coatings, thereby making the pots harder to clean. The sharp edges in the bottom of pots as well as the kettle shape make cleaning harder, as does the holes and hidden surfaces on the handle. Certain users remove the pot holder ring and clean underneath, which is difficult and deforms the ring.

Using spirits is associated with more dishing. Some users have developed their own ways to cope with it, such as by coating the pots with soap before use. Generally, users ask for better coatings to facilitate the cleaning, including on the windscreen where food is spilled or fall down through the gap between it and the pots.

## THE PLASTIC PROTECTOR

Only a third of the users keep the non-stick protector. Many are not aware that it should be saved due to the many recycling symbols on it, and very few read the text on it. Those saving it usually lose it somewhere. Many users instead use multi-discs, wetex cloths or

papers, but others have no protection at all. The size is seen as too small, with it moving around and not covering the sides of frying pans. There is no natural way to grab it, and some users forget it when using the pans, and thus melt it. It is no wonder many ask for other protectors, or at least making it usable, like interesting text on.

## THE MULTI-DISC

Many users do not know of the multi-disc, but those owning it regard it as a good addition with some even bringing two out. A large problem is however the spike on the upper side from the manufacturing that tend to scratch non-stick. Many users use it as a lid when cooking which can cause the plastic to melt. While straining, it has to be held to not fall off, which is regarded as difficult as lacks handles. Some users want it to be made in a material that feels more qualitative, and there are those who find it to be too heavy.

## THE LOCKING STRAP

The strap is liked for the possibility to close an overloaded stove as well as to carry it, and some use it for other purposes when cooking. However, many users do not remove it when cooking as that takes time and it might get lost, and it is often burnt due to this. When locking it, it tends to slide into windscreens with the new holders. It is hard to get the buckle on the right side, and it scratches the frying pans. Many therefore ask for other locking mechanisms for the stove.

## THE COVER BAG

The bag is often used to carry the stove, as it separates dirty stoves from other items. Some find it too large, making the stove rattle, and some find it too small to place all items in. It is much more liked than Primus net-bags that gets stuck in stoves. The bag is often used to place loose items when cooking. However, user ask for waterproof bags not molding, and some want it in the standard kits.

## NEW ACCESSORIES

Many users want new accessories that are made to be placed within the stoves without rattling. A large amount want eating pots or dishes, cutlery and sporks, and cups that fit the stove better than the Trangia cups. Many also ask for a set of cooking utensils, such as ladles and spatulas, as well as spice and oil packages. Others want integrated dish utensils, and quite a few ask for baking accessories, such as ovens or grids. Ignition devices, trangia cloths, racks for not having to place pots in moss, lanterns for the burner, mosquito hunters, gas canister warmers and protective bags for dirty parts are also asked for.

## TRANGIA MINI

Mini is regarded as an important product category for solo lightweight hikers, but is not widely used mainly due to the lack of windscreen and spirits being the only possible fuel. Many users are displeased with the blank sharp handle, hard to grip and trust. The locking mechanism is seen to damage non-stick coatings, which is seen as extra problematic on small stoves. Certain users do not even use the frying pan due to its size.

# APPENDIX 4.

## DETAILED RESULT OF MATERIAL STUDIES

A large amount of different materials were researched, both through the Cambridge Engineering Selector, material fact sheets and through research on new materials on the internet. The Cambridge Engineering Selector is an up-to-date systematic tool to aid in material selection, by attributing certain limits and ranking mechanisms known as the Ashby Method. By investigating materials with high maximum usage temperature, low thermal conductivity, high heat capacity, low abrasion, good fracture toughness, modulus and yield strength as well as good price, a few different alternatives were found. By looking into material fact sheets and researching new materials, a few new materials could be found. Those had very good properties, but were ubiquitously extremely expensive.

The possibilities to test the materials were investigated. Certain materials are possible to be 3d-printed, meaning prototypes could be manufactured. However, it was found that the 3d-printers at Chalmers cannot reach the heat necessary to melt these high-performing plastics. Certain plastic distributors were contacted regarding test trays of material, and some have been obtained while others being on the way. These will be used to test stiffness, test heat used on a Trangia stove, as well as how much they scratch non-stick frying pan.

Most plastic materials are not inherently stiff enough, meaning that they likely have to be reinforced with glass fiber. This does not mean that they will get too expensive, the price can still be fairly low. However, it makes the materials harder to recycle, although it is possible and practised in certain factories in Germany. It will also make them slightly more abrasive.

The handle used today was tested for warmth in different conditions, hanging on a boiling pot outside at 2°C, on a boiling pot indoors at 16.5°C and at a frying pan indoors

at 20°C without any oil or food in it. A computer simulation was done to verify the results, and to test certain plastic materials.

### TEST AND SIMULATION OF THE SITUATION OF TODAY

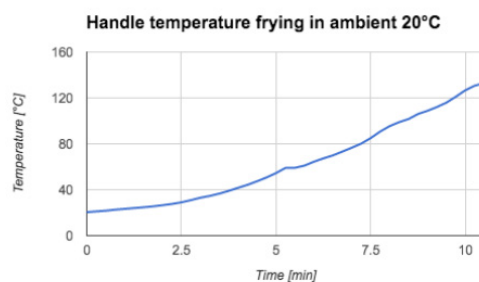
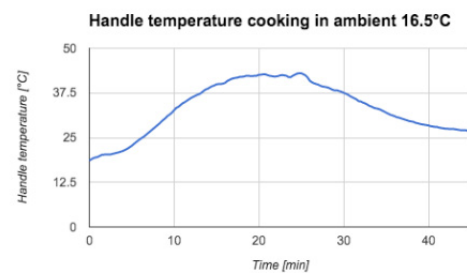
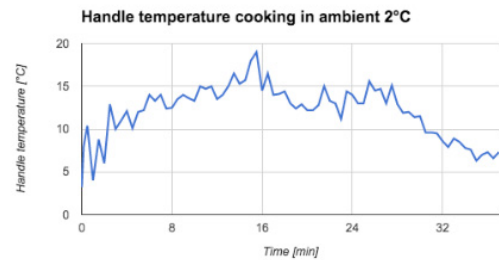

Outside in wintertime, it was found that the handle will likely not reach too high temperatures hanging on the pots, indeed, it did not even reach 20°. Here, the problem is more the cold making the handles cold to touch, see summary of user studies. Indoors, boiling with the handle on makes the handle reach almost 43°C, not dangerous but still too high to be really comfortable. In the extreme case, leaving the handle on an empty frying pan in completely windless conditions indoors, the handle will reach 130°C in ten minutes, far above what is safe and comfortable. The non-stick frying pan had temper-

atures of 313°C, meaning that dangerous fumes were emitted. This means that in summer, the handle will be able to reach too high temperatures.

By making a CAD model of the system with handle and pot, a heat simulation could be done in ANSYS. Using that out of the 1000 W from the spirit stove, 800 W reaches the pot, an extreme case was analysed. The ambient temperature was set to 20°C. The simulation showed that the handle would reach about 140 °C after 10 minutes, very close to the measured value with the frying pan. The bottom of the pan had temperatures between 250 °C and 430 °C, and measured value of 313°C will exist at certain points.

Doing simulations with the material changed, with different plastics, a completely different situation was achieved. The handle still got warm on the shanks, reaching over 100°C, but the grip surfaces had barely got any elevated temperature at all. These promising results lead to further investigation with plastics.

This is an extreme case, and still only the shanks get warm, which is an area rather unlikely to touch. However, a handle in plastics will take longer time to cool than the existing in Aluminium. Possible problems with this need to be investigated. They could arise if packing the kitchen together fast after usage. It can happen that flames will come up to reach the plastic, meaning that it also must

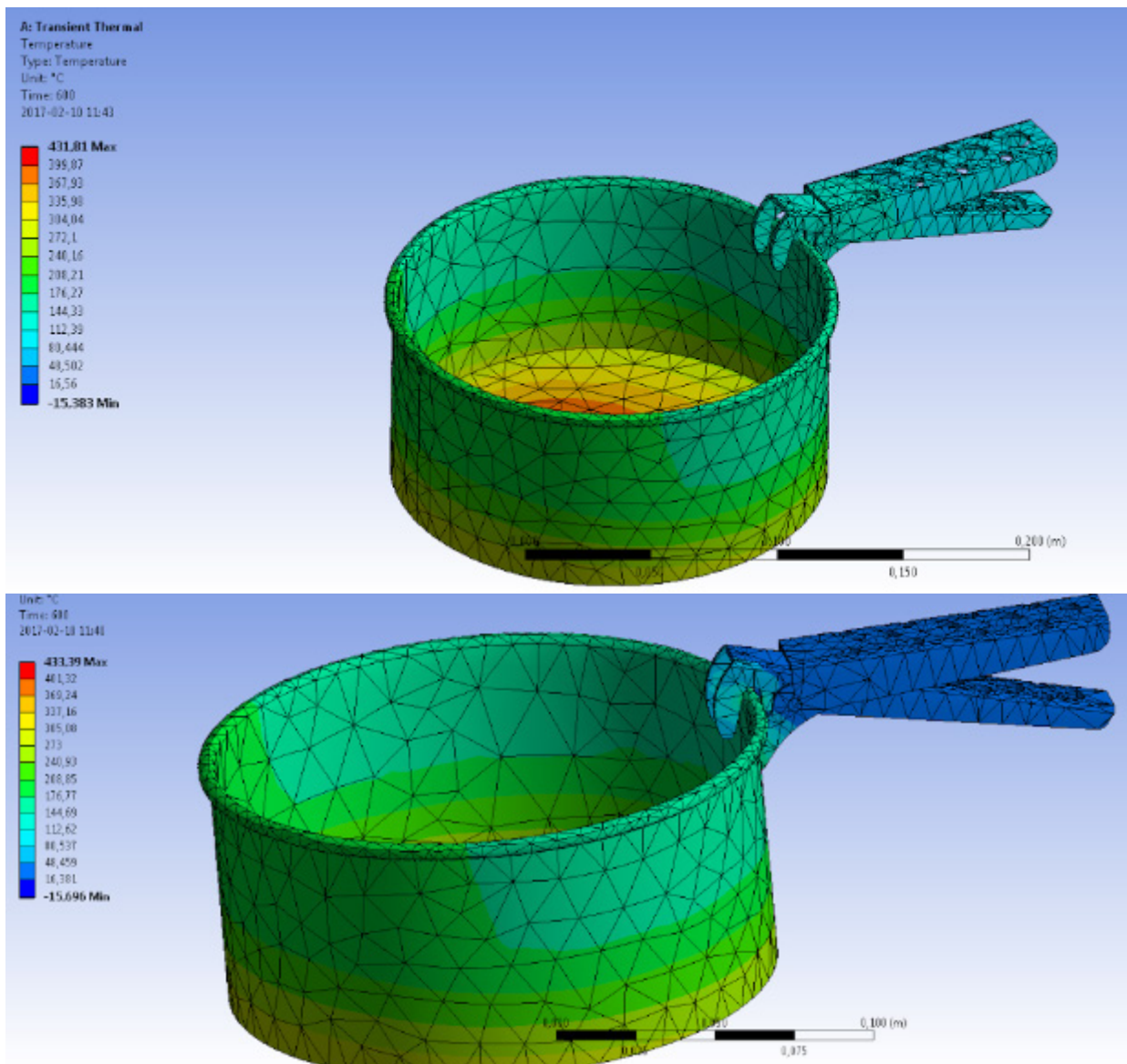

be able to tackle very hot flames short periods of time.

## MECHANICAL INVESTIGATION

Being in contact with professor in mechanics Håkan Johansson, he assured that the main reasons for the handles scratching was likely the looseness in the rivet holding the pieces together, creating a possibility for horizontal sliding, together with the shanks sliding when pressing the pieces together. The reason for the sliding likely arise from pressing the outer part together, not pressing the inner part outwards. The rivet was found to be loose, even on newer handles, which is a problem that should be tackled, to minimise horizontal sliding.

Materials also scratch each others due to differences in hardness. A material with higher hardness will scratch a material with lower hardness, and will scratch it more the larger the difference is. Moh hardness is most important in scratching, but this is a quantity not readily measured for plastics, instead Martens hardness is mostly used for this purpose. Regarding Aluminium, it has a fairly low Moh hardness of about 3, however, Aluminium oxide forming on the exterior of the handle has a very high hardness of 9, scratching the material much more. Much of the scratching also likely come from the sharp edges on the handle, a small contact surface with a high pressure, and horizontal sliding on that.

However, it is in general impossible to anticipate scratching from theoretical data when it comes to polymeric materials. There are a large number of factors interplaying, and to be certain, tests have to be carried out.

## MATERIAL INVESTIGATION

Being in contact with Antal Boldizar, professor in polymer materials, certain insights were gained. Boldizar assured that no material has a hardness low enough to not scratch teflon pans, and intuitively wanted to cover all teflon.

It is important that handles should have low heat transfer to not get warm, not as Aluminium which has high heat transfer coefficient. This is due to the impossibility of having a heat transfer so high that it will lead away more than it gets (this is only possible for Aluminium foil due to the large area/volume)

The materials thus need to have a high melting point, low thermal conductivity, high specific heat, resistance against flames, good mechanical properties and low abrasion due to hardness. However, it must not have too low coefficient of friction, as it still has to be able to grip the pots.

From the studies, a few different alternatives have been found, and are listed below.

## PPS (POLYPHENYLENE SULFIDE)

The single most promising material is PPS. The material has a low heat transfer and was one of the materials used in the simulations. It will not get anywhere close to the temperatures measured on aluminium. PPS does not melt until 315°C, and can be safely used between -45° up until 280°C. The material has a fairly low thermal expansion coefficient, less than aluminium.

PPS has very high dimensional stability, even at high temperatures. PPS is also inherently flame retardant, it does not burn and is self-extinguishing. The flame resistance is so good that it has been used as motor parts for cars, and it has been used for ordinary frying pan handles. Cross-linked PPS, being less brittle, is naturally brown.

It is fairly cheap, even reinforced with glass fibre, at about 40 SEK/kg, compared to aluminium at 20 SEK/kg. Reinforced with glass fibre, it is stiff, has fairly good fracture toughness as can withstand quite high loads. In flexural strength, dominating when carrying pots, it is stronger than Aluminium. PPS has a Martens hardness value of about 156 MPa.

It is possible to manufacture with very high tolerances, however injection molding in certain shapes can be hard due to the high melting point, but it is certainly possible. The material rings rather like metal when being hit, which can be a plus. It is at least theoretically possible to recycle PPS, although not really done in any larger quantities. PPS can be used in contact with food, and there are no known solvents that can dissolve PPS below 200°C. It has excellent resistance to water and works well in the sun.

### PEEK (POLYETHER ETHER KETONE)

PEEK is a high performance plastic with very good properties. It has a very high melting point of 334°C, but can only be used up to 270°C, but down to -60°C. It can be quite strong, both in compression and flexion, and will not get warm thanks to its very low heat transfer coefficient. It is very dimensionally stable, and keeps its stiffness even at high temperatures. It is however less stiff than many other materials. It is also very inert, and will not emit significant amounts of dangerous gases if being exposed to flames. PEEK has a Martens hardness of about 200 MPa. The main issue is the price, standing at 612 SEK/kg, which is very high.

### PET (POLYETHYLENE TEREPHTHALATE)

Perhaps rather surprising, the common PET plastic is actually a possible candidate. The main plus with PET is that it is very cheap, even reinforced with glass fibre, standing at 22 SEK/kg. It has good stiffness, rather good maximum loads, and very good in flexion. It also has a good fracture toughness. However, at a melting point at 256°C and a maximum service temperature at 203°C, it can withstand significantly less heat than the other plastics. A bonus is that it has the lowest emission of carbon dioxide, both in primary production and in molding, and it has good recyclability.

### PI (POLYIMIDE)

Extremely good, but not a candidate thanks to its enormously high price. Being a material that cannot melt, only decompose at 520°C, PI is ideal for usage in high temperature situations. It has extremely low heat transfer coefficient and high heat capacity, meaning that it will not get warm. It can also sustain large forces. However, at a price starting at 1400 SEK/kg, it is way too expensive for such an application as a handle. It is also way overkill, as the low thermal conductivities ensure that the plastic will not really reach such heats.

This same reasoning goes for many other similar supermaterials, such as PAI, which also is very expensive, although less so than PI.

### PCT (POLYCYCLOHEXYLENEDIMETHYLENE TEREPHTHALATE)

PCT is rather expensive, standing at 66 SEK, but has some interesting properties. It is very light, meaning that it will weigh less. However, it has lower stiffness and strength than many other materials, and a rather low fracture toughness. On the positive side, it has the lowest hardness, meaning it is least likely to scratch non-stick coatings. The material melts at 290°C, and can be used up to 260°C and down to -49°C. It has rather low thermal conductivity and high heat capacity, meaning that it will not get too warm.

### PBT (POLYBUTYLENE TEREPHTHALATE)

PBT is fairly cheap, standing at 28 SEK/kg, and has good mechanical properties. It is rather stiff, and has a good flexural strength, and fairly high fracture toughness. However, it has a melting point at only 235°C, and can be used only in between -60°C and 193°C. It has good tolerances in manufacturing, and can sustain many solvents. It is not inherently flame retardant, but needs to be treated with flame retardant.

## PEI (POLYETHERIMIDE)

PEI has rather good mechanical properties. It has quite high stiffness, and can sustain large forces if glass fibre reinforced. It melts at 295°C, and can be used up until 224°C and down to -39°C, not the largest span. It has a low heat transfer coefficient and high heat capacity, and is flame retardant. However, standing at 104 SEK/kg, it is fairly expensive.

## PA46 (POLYAMIDE 46)

A special kind of polyamide that can take higher temperatures than other PA:s, but still only possible to use up to 220°C. PA is not inherently flame retardant, and likely needs treatment. It is fairly stiff, and has can stand quite large forces, especially in flexion. On the positive side, it has very low abrasion coefficient, lower than PPS.

	Al	PPS	PEEK	PCT	PEI	PET	PBT	PA46	PAI	PI
Density	2690	1840	1520	1450	1590	1910	1870	1510	1500	1200
Price	20.3	42.4	612	66	104.5	22	28	85		1400
E-modulus (stiffnes)	71.25	20.7	9.81	9.11	12.4	20.7	14.45	13.5	5	2.5
Yield strength	165	124	141	103.1	175	129.5	110.5	180		231
Maximum strength before break	180	155.5	176	129	191	162	138		150	
Elongation	8	1.005	2.5	1.6	2	0.9025	1.005	2	5	
Compressive strength	165	212.5	150.5	124	221	242	170			
Flexural modulus	71.25	20.6	9.83	9.11	10.85	17.85	17.2	13.5		
Flexural strength	165	264.5	259	185	244.5	276.5	283	330		
Skew modulus	26	7.81	3.62	3.355	4.58	7.81	5.39			
Bulk modulus	68	19.75	11.2	10.65	110.5	19.75	15.05			
Hardness (wickers)	50	37.3	42.25	31	43.7	38.9	33.1			
Fracture toughness	33.5	8.115	6.635	4.645	10.03	9.51	8.17			
Melting point	642.5	315	334	290	295	256	235	325		520
Maximum service temperature	140	280	270	260	224	203.5	193	220	260	
Minimum service temperature	-273	-45	-60	-49	-39	-48	-60			
Heat transfer coefficient	201	0.717	0.21	0.289	0.295	0.729	0.62		0.4	0.12
Heat capacity	900	1160	1050	1370	1300	1130	1150		910	1090

Heat expansion coefficient	23.5	19.8	25	36	15.05	19.1	26.85		20	
Primary production, CO2 per kilo	13.15	8.075	12.3	5.36	7.47	4.99	5.27			
Polymer molding CO2, per kilo		1.495	1.61	1.61	1.335	1.315	1.315			
Burning	Inte brännbar	Self-extinguishing	Self-extinguishing	Self-extinguishing	Self-extinguishing	Self-extinguishing	Self-extinguishing	*	*	*
Contact with food		Yes	Yes	*	*	*	*	*	*	*

# APPENDIX 5.

## REQUIREMENTS FOR THE HANDLE

### Functions of the handle

Requirement	Explanation
The handle must be able to grip all Trangia pots and frying pans, with curved or rolled edges, small and large, in a stable way	<i>This is the main usage of the handle, as stated by Trangia and users. Some indicate that it is not stable for large full pots, which needs to be addressed.</i>
The handle must grip pots tightly, and not slide in any direction	<i>Users indicate that some handles tend to slide sideways when gripping pots.</i>
The handle must not obstruct or hinder the user during usage of the pots	<i>Users state that having the handle continuously on will make it stick out, which will make the product easier to turnover.</i>
The handle must be easy to adjust between gripping and non-gripping position	<i>Users indicate that some handles get stuck in locked position, and that it needs to be fast and quick to change between the positions.</i>
The handle must be able to grip the windscreens	<i>Users use the handle to move or demount hot windscreens, as well as using it to turn the kitchen and thus stir the pot.</i>
The handle must be possible to use to adjust the pot holders	<i>Many users use the handle to adjust the pot holders</i>
The handle must be able to grip an upside-down frying pan without significant obstructions	<i>Users will use the frying pan as a lid upside down the pots, and this shall be easy to remove.</i>
Both major parts of the handle must be possible to grasp separately	<i>The submerged lower part is hard to grasp and remove today if getting stuck, leading to problems for users.</i>
The handle should not open unintentionally during use	<i>The handle sometimes open without notice today, such as when handing over, leading to spilled water and potential burns.</i>
The handle should be able to adjust the simmer ring	<i>Some users try to use the handle to adjust the simmer ring, which usually does not work that well.</i>
The handle could be possible to use for stirring the pot or picking up food	<i>Some users need to use the handle to stir the food and pick up food</i>
There could be a handle with other integrated functions	<i>Some users express their desire for a multi-tool handle with can and bottle openers, and firestarter.</i>

### Durability

Requirement	Explanation
-------------	-------------

The handle must have a lifespan similar to the other parts of the stove	<i>The handle is supposed to be used together with the stove, and must fit into the context of very durable and reliable parts</i>
A working handle must never fail so severely that it cannot be used to hold pots until replaced	<i>Users rely on the stove and the handle to get food being out in the wilderness. The handle can not break entirely in such a situation.</i>
The handle must not get significantly worse performance over time	<i>Users indicate that the handle get bent, especially the lower jaws, and that it tends to get stuck in locked position, as well as loses possibility to hold pots.</i>
The handle must be able to sustain rough handling and tough weather	<i>The handle is often dropped onto the ground and exposed to large forces, and it must thus have good fracture toughness, stiffness and strength. It is also often used in tough weather conditions.</i>
The handle should be possible to repair if damaged	<i>To fit into the Trangia brand and satisfy the users, a failed handle should be possible to repair or bend.</i>

## Manufacturing

Requirement	Explanation
The handle should cost less than 5 SEK to manufacture	<i>A requirement from Trangia, that is shall cost less than the existing handle.</i>
The handle should be easy to assemble	<i>A new handle must be simple to assemble in production, to keep the costs low.</i>
The handle should consist of few parts	<i>In order to make assembly easy, the handle should consist of as few parts as possible.</i>

## Material damages

Requirement	Explanation
The handle must scratch coatings less than the existing handle when gripping pots	<i>Both Trangia and users have expressed concern regarding the tendency for the handle to scratch the surface of the pots and pans.</i>
The handle must scratch coatings as little as possible when gripping pots	<i>Preferably, the handle should take scratching to an absolute minimum</i>
The handle must scratch coatings as little as possible, and less than the existing handle, when being stored in the kitchen	<i>It is generally seen as a larger problem that the handle scratches coatings inside the stove, as this is not only localised to the edges.</i>
The handle must not deform the edges of the pots	<i>There is indication that the handles deform the upper edges of the pots</i>

## Jaws

Requirement	Explanation
The handle should be able to place onto pots without the inner jaw sliding vertically	<i>The inner jaw sliding down on the inside of the pots is a major issue in scratching</i>

The jaws should not slide vertically on pots when changing from closed to open position	<i>Sliding occurs each opening with the existing handle, scratching the pots significantly</i>
The jaws should be able to close without causing temporary pressure points	<i>When only parts of the jaw are in contact with the pot, it will create stress concentrations leading to deformation and scratching. Thus, the entire surface must get in contact simultaneously.</i>
The surfaces of the jaws in contact with pots should be smooth	<i>The rough surface of today leads to severe scratching</i>
The edges of the jaws should not be entirely sharp	<i>Sharp edges in contact with pots contribute largely to scratching</i>
The jaws should not slide sideways when holding the pot	<i>Sideways sliding proves to be an issue in scratching</i>
The jaws should be manufactured in a softer material than aluminium	<i>The hard aluminium oxide forming on the existing handle scratches severely</i>

## Size

Requirement	Explanation
The size of the handle must fit comfortable in the hands of both lowest percentile and the upper percentile	<i>This is a general guideline in making the product usable for as many users as possible.</i>
The handle must be lighter or equal than the existing product, 46 gram	<i>Many users find the handle too heavy.</i>

## Placement

Requirement	Explanation
The handle must be easy to locate during usage, even in dim light.	<i>Users tend to lose track of the handle during cooking.</i>
The handle must be easy to fit within the stoves, and in kettles for both 25 and 27	<i>It is important that the handle can be stored within the products</i>
The handle must fit in well-packed stoves in double edition	<i>Many users bring two handles, as well as filling their stoves with many items.</i>
The handle should have an obvious placement within the packed kitchen	<i>One of the problems today is that the handle has no clear position, and rattles when placed within the kitchen.</i>

## Temperature

Requirement	Explanation
The handle must withstand the heat generated by normal cooking	<i>Many users have the handle on the pots, and the handle must be able to withstand that, which is also stated by Trangia.</i>

The handle must sustain flames from the burner	<i>The handle must not melt or deform during normal usage close to the burner</i>
The handle must not get uncomfortably or dangerously warm during usage	<i>There is indication that handles sometimes get too hot when using it.</i>
The handle must not get uncomfortably cold during winter	<i>Many users indicate that the handle gets too cold for comfort at low temperatures.</i>
The handle should not freeze together during winter	<i>Many users have experiences handles that freezes together and is very hard to open during winter.</i>

## Physical ergonomics

Requirement	Explanation
The handle must be comfortable to grip and hold for prolonged times	<i>Many users indicate that the handle is uncomfortable today, due to the sharp edges and the square form, especially when holding longer times.</i>
The handle must be possible to use with a soft grip	<i>Users indicate that they feel that they have to hold the existing handle convulsively hard to not drop it, which is undesirable.</i>
The handle must not have sharp edges that users can cut themselves on	<i>Some users cut themselves at the sharp edges, and some need to file them down in order to use the handle</i>
Users must not be able to pinch their hands using the handle	<i>Some users clamp their hands when closing the grip, sometimes leading to bloodshed. Others only clamp their gloves.</i>
The handle should be comfortable to hold in both open and closed position	<i>The handle today is regarded uncomfortable to hold when being open.</i>
The switch between open and closed position of the handle should be comfortable	<i>The switch between open and closed position demands a significant regrip, leading to discomfort as well as handling problems.</i>
The handle should be possible to use with gloves or reduced movements	<i>The handle is hard to use with gloves, which is often used during winter.</i>
It should be possible to take different comfortable grips on the handle	<i>Users often like to vary their grips, and it should be possible to do without fear of dropping food.</i>

## User experience

Requirement	Explanation
Users must feel that they trust the handle	<i>There is indication that some users do not trust the existing handle, often without knowing why.</i>
The product must be experienced as sturdy and robust when lifting the pots	<i>Certain users feel that the existing handle is unsteady, and take hard grips around it.</i>
The product must be experienced as durable and thought-through	<i>The handle must fit into the tradition of Trangia stoves, and therefore be experienced as a very durable and thought-through</i>

## Construction

## Requirement

## Explanation

The handle should be possible to make in standard manufacturing equipment

*To decrease costs, no unsimple manufacturing procedure should be utilised if avoidable.*

The handle should have few protruding parts

*To prevent the handle from getting stuck, as well as making it look streamlined and nimbler.*

The handle should rattle and be subjected to automated open-close episodes as little as possible

*The existing handle sometimes rattle in the packed stove, and tends to open and close leading to scratching the pots and pans.*

## Cleaning

### Requirement

### Explanation

The handle shall be easy to clean

*Some users experience the handle as hard to clean due to the enclosed surfaces and holes.*

## Environmental aspects

### Requirement

### Explanation

The product shall harm the environment as little as possible

*Although not widely mentioned by users, this is a requirement by Trangia, which also gives a good selling point.*

The product should be made in a recyclable material

*If possible, it would be positive, as stated by Trangia*

## Aesthetics

### Requirement

### Explanation

The product shall bear the Trangia logotype

*Trangia states that this is the most necessary part of the visual brand identity.*

The product shall visually fit together with the Trangia brand identity

*The users must feel that the product is not misplaced, and this need to be tested with evaluation methods.*

The handle should be regarded aesthetically pleasing

*Certain users are not that pleased with the existing handle, and the handle should look good.*

# APPENDIX 6.

## REQUIREMENTS FOR THE STOVE

Requirement	Explanation
Trangia Mini	
Trangia Mini shall have wind protection	<i>The main reason for not using the mini is the lack of windscreens. A large number of users want a real Trangia kitchen with lower weight and volume, and a Mini with some wind protection could fulfill his.</i>
Trangia mini should be possible to use with other burners than spirit	<i>Several users choose to not use the Mini due to lacking fuel possibilities. Gas is the main fuel, but requests have been made for multi-fuel as well.</i>
Users should not hurt themselves on the edges of Trangia Mini	<i>Users indicate that the edges on the lower part of the Mini are too sharp</i>
The locking mechanism should hurt the non-stick coating as little as possible	<i>There is evidence that the locking mechanism tears the non-stick frying pan.</i>
The handle for Trangia Mini can be less sharp and gripping better	<i>The handle is generally seen as too sharp to hold and not gripping the pots ultimately. It was seen as hard to hold it for longer times, as when eating. However, the low weight is seen positively</i>
There could be a lighter burner for Mini	<i>Indications show that the burner is sometimes seen as too heavy for a low-weight kitchen.</i>
There could be a version slightly larger than Mini but still light	<i>Some users see the Mini as too small and unusable and the 27 as too large.</i>
The simmer ring	
The simmer ring shall be easier to adjust when using the burner	<i>One of the largest problems is the sluggish simmer ring, which is almost impossible to adjust when burning. The entire ring spins around when users try to adjust. Users fail, get angry at the product and sometimes hurt themselves.</i>
The simmer ring should be possible to adjust from the outside of the stove	<i>It is generally disliked to put hands down into the heat, and ideally the simmer ring could be adjusted from outside the stove, as by mechanical transfer</i>
The simmer ring should give central heat even when using less effect	<i>There are complaints about the flame turning around the pots, and not giving good heat when having the simmer ring adjusted. Other possibilities could be done, as a aperture-like function</i>
The spirit burner	
The spirit burner shall be easier to use when cooking longer times	<i>Users indicate the problem of the spirit burning out before the food is ready, waiting for it to cool, and some have got hurt by filling it too early. Wishes have been made for larger spirit capacities.</i>
The spirit burner shall have higher power output	<i>Many users indicate the problem with the waiting time when using spirits.</i>
The users shall be aware and able to use the spirit burner with less soot	<i>Many users indicate the problem with formation of soot on the pots, and see this as a major drawback of spirits. Few know that dilution with water decreases soot. Users indicate that the burner itself gets full of soot and hard to use.</i>
The users shall be aware of how much fuel they need	<i>Users are usually not aware of the amount of spirits they need. It is both a problem with too much fuel and too little. Some see a burner with a scale, also indicating maximum filling as a solution</i>
The burner should leak less	<i>Many users tend to transport fuel in the burner, both left since the last burning but also as a way to transport it for shorter trips. Many are not aware of the condition of the gasket.</i>

<b>The bag for the spirit burner should have a natural placement when cooking</b>	<i>Some users just put things on it, just place it on the ground or use the coffee pot, until it is used. The bag needs a better natural place to be.</i>
<b>The spirit burner could be easier to ignite in windy conditions</b>	<i>There are indications that users have a hard time to light the burner when it is too windy, and some do not like to put the hands down the windscreen and light it there</i>
<b>The spirit burner could have a better bag</b>	<i>Some users tend to burn their plastic bags, although some are known to last for years.</i>
<b>The gas burner</b>	
<b>The hose end shall be easier to mount, especially regarding passing through the hole in the lower windscreen</b>	<i>Many users indicate problems pulling the large hose end through the hole, especially after having the burner mounted, or if the hose is twisted. Some thus propose kitchens with integrated gas burners, due to the problems today.</i>
<b>The gas burner should be possible to obtain with a lower sound volume</b>	<i>Users indicate that they want silencers directly from Trangia</i>
<b>There should be a gas burner with a longer hose</b>	<i>Users indicate that the hose is too short to use with slightly larger gas tubes in a good way. The rigid hose sometimes turns the kitchen over if the gas tube rolls over.</i>
<b>The gas burner should have more precise gas flow regulations</b>	<i>Some users complain about the regulation of the gas flame not being enough precise.</i>
<b>The gas burner should not deform over time</b>	<i>The gas burner tends to deform over time, and not getting into the hole in the lower windscreen.</i>
<b>The gas burner should corrode less than today</b>	<i>There are indication of the burner easily corroding, and the swiveling coupling not being good enough.</i>
<b>The gas burner should be safer to ignite</b>	<i>Some users find it dangerous to ignite the gas burner within the windshield, due to accumulated gas let out before that can burn. And igniting it without windshield is significantly harder.</i>
<b>The gas burner should be easier to pack into the kitchen</b>	<i>Users indicate that it is hard to make room for the spirit burner in the kitchen, especially thanks to the rigid hose. Some even want to pack two to be able to cook more.</i>
<b>There could be a gas burner with integrated ignition</b>	<i>Many users ask for gas burners with integrated ignition. However, indications show that Primus burners with piezo igniters break, and the solution have to be more robust.</i>
<b>The gas burner could be lighter</b>	<i>Certain users see the weight of the burner as a large drawback, comparing with other lighter gas burners.</i>
<b>There could be a gas burner where fuel could be placed under the lower windscreen</b>	<i>Some users want to place the fuel directly below the upper windscreen. However, others see problems with the heat regulation that needs to be solved.</i>
<b>There could be a more robust bag for the gas burner</b>	<i>There are indications that the bag gets worn after some time, and some would want a more robust bag.</i>
<b>The multi-fuel burner</b>	
<b>The multi-fuel burner should have better regulation</b>	<i>Users indicate that the multi-fuel burner is hard to regulate, and some like the older versions with double control better.</i>
<b>The multi-fuel burner should be easier to mount</b>	<i>Indications show that the multi-fuel burner consist of many parts hard to assemble</i>
<b>The multi-fuel burner should have lower volume</b>	<i>Users see the volume as a negative, and some have obtained quietstoves especially made for Trangia multi-fuel burners.</i>

<b>The multi-fuel burner should fit into the kitchen</b>	<i>Indications show that the multi-fuel burner should be possible to store within the kitchen for easiness.</i>
<b>The multi-fuel burner could be possible to use without the kitchen getting too hot</b>	<i>There are indications that many parts of the kitchen get really warm, and no plastics can be left within the pots without melting.</i>
<b>The multi-fuel burner could be possible to use with gas</b>	<i>Users generally like to have as few parts as possible doing as much as possible, and comments regarding this functionality exists.</i>
<b>Fuel</b>	
<b>There should be more gas tubes that can be packed into the kitchen</b>	<i>Many users see the integrated solutions as Trangias biggest advantage, and want to pack the fuel in the kitchen as well. The smallest tubes now get room, but different shapes on the tubes could give more gas.</i>
<b>There should be fuel bottles that can be stored better</b>	<i>Some users want to keep spirits or multifuels in a better way, and certain want to have that within the kitchen as well.</i>
<b>There could be products to keep the gas tubes warm in the winter</b>	<i>Users see the problems during winter as the largest for the gas fuel, and some suggest insulators from Trangia.</i>
<b>The Multidisk</b>	
<b>The multidisk shall be made in a more heat resistant material</b>	<i>Some users note that the multidisk is easily scratched when using it. Some tend to see it as getting scabby, even suggesting it to be made in wood (at least one side)</i>
<b>The multidisk shall be made in a more scratch resistant material</b>	<i>Users want to use the multidisk as a lid when cooking, leading to the disk melting. It should be made in a material surviving the heat,</i>
<b>The multidisk shall not have a sharp rod in the middle of the top side</b>	<i>As a result of the manufacturing, a small sharp rod is left on the multidisk top, which scratches non-stick coatings as well as the plastic protector.</i>
<b>The multidisk should not fall off when pouring water</b>	<i>The multidisk tends to fall off by itself when leaning the pots. Some users want to solve this with better grips on it, as dips on the surface. Ideally, the disk should not fall off in the first place.</i>
<b>The multidisk could get lighter</b>	<i>Some users see the multidisk as too heavy, and will not bring it.</i>
<b>The pot holders</b>	
<b>The frying pan and the largest pot shall be possible to use with more wind protection</b>	<i>One of the largest problems is that the frying pan as well as the large kettle gets too high up, rendering the windscreen unnecessary. Users try to cope with this by drilling holes in the upper windshield and placing it directly on the windshield. Some hold the pan constantly at a lower height above the windshield when using it, which is tiresome and renders a hot handle. Using the 27-frying pan on the 25 proves to work.</i>
<b>The pots should be possible to place more stable on the pot holders</b>	<i>Users indicate that pots, coffee kettles and especially frying pans tend to tip over. Frying pans more so due to not having a protecting windshield. Some see the holders as too "flimsy"</i>
<b>The pot holders should not scratch the non-stick coating when packed together</b>	<i>Users indicate that pot holders are major contributors to scratching in packed version of the kitchen, due to them not being fixed.</i>
<b>It should be easier to clean the area around the pot holders</b>	<i>Users tend to bend the holding ring away to clean the interior of the upper windshield, which is hard to do, deforming the ring and leading to diminished fit.</i>
<b>The pot holders should be more durable</b>	<i>There are indications that pot holders get bent and that pots do not fit after that</i>
<b>The change between pot mode and frying pan mode could be smoother</b>	<i>Some see the change as hard to do, especially when the fuel being burnt. Many use the handle, but not all see it as optimal.</i>

<b>The pot holders could interfere less with the packing of the kitchen</b>	<i>Indications show that the pot holders are seen to be in the way when packing the kitchen</i>
<b>The pot holders could be less sharp</b>	<i>There is some indication that the holders are too sharp.</i>
<b>The Upper Windshield</b>	
<b>There should be a more windproof upper windshield</b>	<b>The windshield is not enough in certain conditions, especially by the ocean or in severe storms, according to users.</b>
<b>The windshield could if possible scratch the nonstick frying pans less</b>	<b>The connection between the windshield and the frying pan is said to scratch the non-stick coating</b>
<b>There could be a lighter windshield</b>	<b>Certain users look for a lighter version of the windshield, which still is more rigid and usable than external foil, that usually just blows away.</b>
<b>The Lower Windshield</b>	
<b>The users should be guided in that the holes are to be placed towards the wind</b>	<i>Few are aware of this fact, and even fewer think of it.</i>
<b>There should be a lower windshield with more robust top surface</b>	<i>Users indicate that the top of the lower windshield sometimes deforms, and that burners are hard to place within it after that.</i>
<b>There could be a windshield that is more forgiving when it comes to uneven ground</b>	<i>Users normally have to jack up with multidisks or stones to get the windshield to stand stable.</i>
<b>There could be a lower windshield not reflecting heat towards the ground</b>	<i>Some users see lost heat downwards as a problem, both by lost efficiency as well as the fact that grass can start to burn.</i>
<b>There could be a lower windshield with less height</b>	<i>Some users see the windshield as too heavy, and propose a lower height. However, several like having a good cooking height, so a lower windshield should not be the only one existing</i>
<b>There could be a windshield with room for two burners</b>	<i>Some users indicate the wish for another design of the windshield, that can sustain two burners at a single time</i>
<b>The non-stick protective plastic</b>	
<b>There shall be a multifunctional, permanent non-stick protector</b>	<i>Many users throw the plastic away, not realising its function thanks to the recycling symbols, does not like plastics, or it blows away. Some have managed to break it.</i>
<b>The non-stick protector should protect the entire non-stick surface</b>	<i>The plastic protector does not protect the sides of the frying pan, making these extra vulnerable</i>
<b>There should be a natural placement for the protector while cooking</b>	<i>Users tend to put the protector at different places, some put things on top of it, some crumple it together and some forget it in the frying pan. It often blows away.</i>
<b>The kettle</b>	
<b>The kettle could be easier to clean</b>	<i>The internal edges make the kettle hard to clean for certain users</i>
<b>There could be a lower kettle that can be stored within the pots</b>	<i>There is indication that the kettle is higher than the pots, making storage harder</i>

<b>The users should understand and be able to use the kettle without melting the plastic coating on the handle</b>	<i>Few take off the plastic coating on the handle when using it over fire, and this usually gets molten.</i>
<b>There could be a tea insertion for the kettle</b>	<i>Users drinking tea see a need for a foldable tea leaf holder to be placed within the kettle</i>
<b>There could be an insertion for filter coffee</b>	<i>Some users state that they do not use the kettle due to not liking boiled coffee.</i>
<b>The pots</b>	
<b>It should be easier to keep the pots warm</b>	<i>Users do all sort of things, bring extra burners or grills to keep the pots warm when cooking something else.</i>
<b>There could be pots with heat exchangers</b>	<i>Many users ask for pots with heat exchangers, and some ask for removable versions that can be used sometimes.</i>
<b>There could be other lids than the frying pan</b>	<i>Some users want to have lids for both pots, or doesn't want to bring the frying pan.</i>
<b>It could be possible to remove pots without having to remove the lid first</b>	<i>There is indication that it is problematic to remove the lid before removing the pots, especially during winter</i>
<b>The frying pan</b>	
<b>The frying pan should not slide away when used as lid</b>	<i>Users see this a a problem, and a main reason for turning the frying pan upside down.</i>
<b>The strap</b>	
<b>The strap should not melt when not being taken off during cooking</b>	<i>Many users do not take the strap off when cooking, and as a result get the strap molten. There should be a strap that can handle this.</i>
<b>The buckle should not scratch the frying pan</b>	<i>There is indication that the buckle can scratch the underside of the frying pan when mounted.</i>
<b>The strap should be possible to thread through the loops without falling into the kitchen</b>	<i>Many users indicate that it is harder to pull the straps through on the new kitchens.</i>
<b>There could be an alternative way of closing the kitchen</b>	<i>Many users want another closing mechanism than the strap, although the advantage is that more can be packed into it and it being more secure, and possible to use to carry the kitchen.</i>
<b>General shape</b>	
<b>There should be a kitchen that rattles less when carrying it</b>	<i>A large number of users are dissatisfied with the kitchen rattling when carrying it, and many put papers between pots to make them fit together.</i>
<b>There should be more compact versions of the product</b>	<i>Quite a few users express the need for a kitchen that is easier to store.</i>
<b>The product could be more modular without rattling when packing</b>	<i>Many users only want to pack certain parts of the kitchen when going out</i>

<b>New side products</b>	
<b>There should be food bowls that easily can be stored within the kitchen</b>	<i>Many ask for integrated food bowls, to make the solution even more complete. These could be thin, in plastic, and stored in the play between the pots, and perhaps used to keep these warm.</i>
<b>There should be cooking utensils that can be stored easily within the kitchen</b>	<i>Many users need to bring ladles and spatulas, and would like this to fit into the kitchen</i>
<b>There should be cutlery that can be easily stored within the kitchen</b>	<i>Some users ask for a cutlery set that fits nicely within the round shape without rattling</i>
<b>There could be an ignition device that can be stored easily within the kitchen</b>	<i>Some users tend to forget ignition devices at home, and many already store it within their kitchens. Some ask for a special igniter that can be placed naturally within the kitchen</i>
<b>There could be extra baking details that can be stored easily within the kitchen</b>	<i>Many users try to bake bread within their kitchens, and some want details to make this easier.</i>

# APPENDIX 7.

## ADDITIONAL RESULTS OF IDEATION 1

The first part of the ideation resulted in many different ways to hold a pot. Unrealistic ideas such as adhesives were quickly discarded, and it was found that some kind of grip or external fastening mechanism on or around a pot was needed. Both of these categories were developed in many different ways. The handles were quickly found necessary to grip the pot from one side, with ideas gripping across the pot either becoming too large, too telescopic to clean or too weak. The fact that the pots are submerged within the windscreen further restricts the possibility to use certain methods for fastening the handle.

Three main mechanisms were found to be possible: classic rotational mechanism, caliper mechanisms and permanent or semi-permanent handles. The permanent handles include fastenings in different ways on pots with hinges in some way while semipermanent handles could be hanged on, screwed on, snapped on or stuck into holes. These categories have in common that they cannot be used without modifying the pots. Other mechanisms such as rotating in parts of the shanks from the side or another axis or snapping the handle together each time were discarded.

Investigating the rotational mechanism, it was found most efficient to have the rotational point at the front end, just as the handles of today. This is both due to the distance created to the back giving rise to a level effect and thereby allowing for a softer grip at the back, as well as not making the handles fall off even if opening. This means that the two parts must cross each other, so that the lower part grips the inside. Investigating the possibilities to have a self-locked handle it was found that it is impossible to obtain that by shape only with two parts on a pot with different cross-section where the handle grips. Had the pots not been curled on top only, the inner shanks could be u-shaped to hang on both sides,

preventing the upper part from falling down. The curled edge leads to a gap created in a u-shaped shank, making it fall down.

A way of having a rotational handle was found by letting the rotational rod protrude from both edges of the outer part, with holes in the middle. The rod has to have a cut-off cross-section shape, and a cavity in which it can fall down when rotated into closed position, either automatically or manually. The shapes are somewhat similar to what is found in pipe-wrenches today.

To obtain a lockable rail mechanism, rails with different shapes were investigated. A rail that is first straight followed by a smooth hill upwards and a steep hill downwards would not open itself, but would be rather hard to open when desired. An interesting idea that is somewhat self-locking but still easy to open is the tilted caliper mechanism. A slanted rail leads the handle to either slide into closed position by gravitation, or by very little force when pushing forward. Gravitation will make it stay in locked position, and opening is easily done by pushing backwards. Models all these mechanisms were built in capa and wood, assuring that they indeed will work, but might need more exact specifications to be optimally used.

Many different shapes were investigated, first on paper and later in reality. Many ideas concerned rounded handles, grip surfaces on the lower side, submersions for fingers as well as a major change in making the back of the handle tilted downwards. Generally, the ideas concerned better grips, where both parts could be felt and held, not completely getting submerged into each other. Base sketches of the existing handle in different angles were created in Photoshop as a basis for sketching other shapes while still maintaining the overall length. Multiple copies of these base sketches were made and sketched upon. Different means of locking the handle were investigated, from snap-on fastenings

to automatic mechanic solutions or opt-in manual ways, as well as how these could be shapes to fit the hand and be easy to understand.

Different means of locking the handle were investigated, from snap-on fastenings, to automatic mechanic solutions or or manual ways. As a major problem was losing the handle due to it having no clear place as well as the fact that many users feel it loses its grip, it was regarded important enough to become a category of its own.

The four main categories for further sketching was selected to be Rotational Mechanisms, Caliper Mechanisms, Semipermanent/permanent Mechanisms, and handles with fastening buttons. The latter category was chosen to exist on its own even if not a base mechanism, due to the importance of handles getting lost when not having a clear place as well as losing the grip. Models with tilted handles were found very promising for the grip, and new subcategories were selected to further explore the idea space.

1. Rotational mechanism
  - 1.1 Straight but more ergonomic
  - 1.2 Tilted grip surface
2. Caliper mechanism
  - 2.1 Straight ergonomic handle
  - 2.2 Tilted grip surface
  - 2.3 Tilted caplier mechanism
3. Fastening mechanisms
  - 3.1 Snap-on button
  - 3.2 Sprint
4. Semipermanent/permanent handles
  - 4.1 Hinge mechanism
  - 4.2 Rotational fastening mechanism
  - 4.3 Snap-on handle

These different bases were chosen for investigation by sketching shapes and mechanisms. The investigation lead to six promising concept bases that should be developed. The rotational fastening mechanism for semipermanent handles were found to be working, but the gain in doing so would be very little compared to completely perma-

nent. For the handles to be fastened by rotating, it needs to be so tight as it more or less becomes permanent. Snap-on handles would be possible, but even harder to remove if being secure in all directions.

The rotational-lockable handle

The basis for this concept is the normal working rotation, but that the rotational pin is cut-off chamfered, giving that it can be actively pressed down in a non-rotational cavern when closed. This leads to the handle being possible to lock, but not necessarily locked.

The rotational snap-button handle

This concept combines a normal rotation and two snap-buttons on the sides that automatically snap together when closing the handle. The handle will thus always be locked when closed, and is opened by pressing the two side buttons simultaneously.

The rotational sprintlock handle

This handle works like a normal rotational handle, but has a small fastened sprint that can be pressed or rotated to opt-in lock the handle.

The springloaded caliper handle

This handle works like a caliper, held by a spring. The front shall actively be pressed forward to open, and is normally pulled into closed position by the spring.

The slanted angle caliper handle

This handle has a slightly slanted rail, giving that it easily falls forward into position, and will stay in that closed way. It is still easy to slide it backwards to open it when needed.

The permanent hinge handle

This handle is instead completely permanent, fastened on the pots permanently, and rotated in over the pots when packing the set. This leads to the handle not getting lost.

To finalise the shapes, seven different clay models were taken into evaluation. Six persons with different gender and hand size were testing the handles.

The handle pictured to the right was rated highest, on average 4.5 on a scale from 1-6. The possibility to rest the index finger as well as the lower end of the hand were liked, but the end was disliked by those with larger hands.

The next handle was rated second highest, with 4.3, but it different significantly. If the finger submersions fitted the test person hands it was rated as very comfortable, otherwise the finger submersions were found to be uncomfortable.

The following handle was rated 4 on average. The small submersions on the top for the thumb, and on the lower end for the rest of the fingers were liked very much. They were found to be small, but not disturbing if the handle was gripped in other ways or by various hand sizes.

The other handles were regarded in order as being too bent, too square, having a too deep thumb grip, and better to grip upside down but still too large difference in cross-section area.

After evaluating the results, the first and third models were used as a basis for further development.. The first grip was chosen due to the appreciated index finger rest, and the third due to the simpleness and versatility in grips.

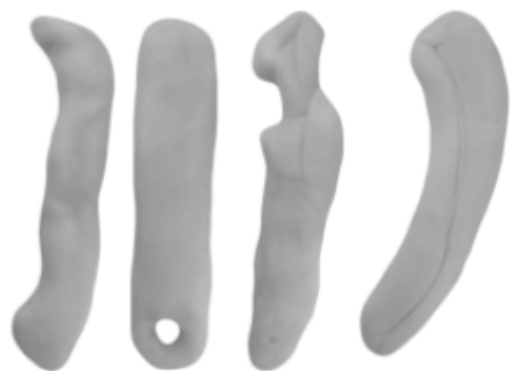

# APPENDIX 8.

## INTERVIEW GUIDE FOR CONCEPT TEST 1

Hur bekvämt är handtaget att hålla?

Hur bekvämt är handtaget att hålla i öppet läge?

Hur bekvämt är handtaget att hålla i stängt läge?

Hur bekvämt är det att lyfta en kastrull med handtaget?

Hur bra tycker du att mekanismen är?

Hur estetiskt tilltalande tycker du att handtagets formspråk är?

Skulle du vilja ändra något på handtaget, och i så fall vad?

Vad i detta handtag är det du tycker om?

Vad i detta handtag är det du inte tycker om?

Slutligen

Vilket handtag har bäst form?

Vilken mekanism föredrar du?

Om du fick välja ett handtag, vilket skulle du vilja ha?

Om du fick kombinera ihop olika aspekter, som form och mekanismer, vad hade du velat ha?

# APPENDIX 9.

## SUMMARY OF RESULTS FROM CONCEPT TESTS 1

Presslock	Downslide	Springslide	Pinlock	Snapbutton
Simple mechanism	Allows similar grips in open and closed position	Intuitive to use	Only needs to be locked if desired	Rather simple mechanism
Simple to lock	Simple mechanism	Allow similar grips in open and closed position	Can be used with one hand	May still works even if the locking mechanism fails
May still work even if the locking mechanism fails	Is closed and not locked, making it easy to open	Can be used with one hand	Is easy to open and close	Could be made to only consist of only two parts
Only needs to be locked if desired	Can be used with one hand	Would likely work well even if the user is wearing gloves	The handle still works even if the locking mechanism fails	
Consists of only two parts	Consists of only two parts		Simple mechanism	
Releasing is hard with the existing shape	Releasing is hard with the existing shape	Will totally fail if the spring breaks.	The sprint may get stuck in in-between position,	Will be difficult to open if the inner part gets stuck.
The rotational rod can cause wear that can destroy the mechanism.	A particular angle, or friction lock is needed for it the handle work.	To hold the pots, the required spring strength could make it hard for the user to push the lock open.	The sprint may open by mistake or be impossible to close	The outer part may become pressed inwards when trying to open the handle
The locking mechanism is located close to the heat	Might need two sliding mechanisms to prevent rotation	Pulling back and forth may cause wear in the plastic	May be experienced as harder to lock than other mechanisms	The mechanism will force users into certain grips to not push buttons unintentionally
Releasing the handle may require two hands	The mechanism may require a strong grip to close	Will be harder to assemble.	The sprint might be hard and unintuitive to reach at current position	Can be hard to use in cold weather or with fumbling hands
		Will be hard to clean.		The plastic buttons may wear out

				Might not work with one hand
--	--	--	--	------------------------------

### Shape, aesthetics and ergonomics

Presslock	Downslide	Springslide	Pinlock	Snapbutton
<p>The open construction makes it easy and comfortable to maneuver in open position.</p> <p>Sufficiently square to avoid rotational displacement in hand.</p> <p>Provides a sufficient grip for larger hands while still being experienced as a light handle</p> <p>4/8 users picked this shape as their favorite</p>	<p>The round shape is comfortable for many different grips</p> <p>The small gouges fit different hand sizes quite well</p> <p>Does not require the user to change grip between open and closed position</p>	<p>The rear tilted end allows safer grips</p> <p>Can be gripped in many different ways</p> <p>Does not require the user to change grip between open and closed position</p>	<p>Experienced as a small and light shape</p> <p>Fits inside the Trangia 25 kettle.</p>	<p>The shape fits well for many hand sizes</p> <p>The rear tilted end allows safer grips</p> <p>Fits inside the Trangia 25 kettle.</p>
<p>The comfort is very dependant on hand size</p> <p>The height of the handle takes up space and makes it less comfortable for smaller hands</p> <p>Might not look like Trangia</p> <p>The separated parts lead to</p>	<p>Too large radius to fit smaller hands</p> <p>Would work better with an index finger rest to slide with.</p> <p>The round shape can cause the handle to rotate in the hand when lifting and pouring from the pots.</p> <p>The thumb gouge is too shallow to</p>	<p>The comfort is very dependant on hand size</p> <p>The rear end is too sharp</p> <p>Will be hard to wash</p> <p>The sliding function is located</p>	<p>The comfort is very dependant on hand size</p> <p>Has no heat protection in the front</p> <p>Uncomfortable to hold in open position</p> <p>The placement of thumb and index</p>	<p>The back gable and full part submersion makes it hard to open</p> <p>The tilted end is too pronounced for many hands</p> <p>Uncomfortable to hold in open position</p> <p>The placement of index finger</p>

sideways sliding and easier deformation	provide enough grip when opening and closing the handle	where the hand holds	finger submersion is very hand size dependant	submersion is very hand size dependant
Does not fit inside the Trangia 25 kettle as is	The current version might have a too sharp end.	The rear tilted end leads to more material	Was described by some users as having too many edges to be really comfortable	The rear tilted end and index finger grip means more material
	Does not fit inside the Trangia 25 kettle as is	Does not fit inside the Trangia 25 kettle		
	Received poor aesthetic marks.	The prototype was described as too large and heavy		
		Received poor aesthetic marks.		

# APPENDIX 10.

## DEVELOPMENT OF GRIPSLIDE

The development of Gripslide was based on input from the tests, especially regarding concept Downslide. The phase began by investigating the possible shapes of bent aluminium, by cutting and bending paper complemented by sketching. Ideas were iterated between sketches and cut paper. It was found that the production method affects the shape to a very high extent. It leads to basically rectangular cross sections, with distinct radii at the bending areas. Even though the round shape of Downslide was comfortable, it did not fit the mechanism and a new design was needed nevertheless.

The new concept was iteratively built in CATIA Generative Sheet Metal, to assure that it could be manufactured by stamping and bending. Numerous versions were 3d-printed to test functionality and thereby modify the design. Insights were gained regarding the ways in which metal could be bent, and the design was altered severely during the process.

Sliding a handle into closed position proves to work for almost any shape, but opening will demand support for the fingers. Various ways of achieving this were explored, such as folding a metal piece downwards at the lower front end or making a finger hole at the same place. The latter proved to be effective but uncomfortable. A finger hole on the upper side proved to work better, due to the short periods of time being used. Different textures on the upper side was tried to increase friction between finger and handle.

The acting forces were studied to understand how they affect the handle design. Were the inner jaws slid down and backwards into place, scratching would be even more diminished. However, gravitation would act to open the handle, and thereby making it less secure. With the outer jaw being slid down and forward into place, the natural forces instead act to close the handle.

The slid part was tested to be on the inside as well as on the outside. An inner slid part proves to be more comfortable, but more prone to open accidentally. This is due to it not being held together by the whole hand. The upper surface was tried to be flat as well as slanted, but the later proved to make sliding too easy.

Different versions of the jaws were tried, and all needed one more bending step in production in order to increase the contact surface. Gaps between the bent and non-bent parts were necessary to introduce for manufacturing purposes. Jaw angles differing from 90° were tried, as were different configurations to support the pot edges. It was found that a more or less complete hole around the edge is possible, if the edge follows the sliding angle.

# APPENDIX 11.

## DETAILED RESULTS OF CONCEPT TESTS 2

Gripslide advantages	Gripslide drawbacks	Plier advantages	Plier drawbacks
Will scratch pots much less due to sliding movement	Might be harder to use with gloves	Lighter weight	The two parts might be hard to separate with hands and fingers if stuck in closed position
Eliminates the risk of pinching users when closing the handle	Will need one more step in assembly	Is more similar to what users are used to, making it very intuitive to use.	Does not provide sufficient support for the whole hand
Regarded as more comfortable by users	Might be harder to use if the rail is jammed or gets very worn by wear	Would be easier to open and clean	Some users feel they don't have a sufficient grip around the lower part to keep the handle closed
Will not fall off pots by itself and thus eliminates spilling and third-degree burns	Some users are not sure if they would trust the handle due to their limited experience with this mechanism in similar products	Will likely not be left on pots and get warm	The rear upward tilt on the lower part does not fill most users hands
Offers additional heat protection through the finger rest	All users may not understand how it works the first time they see it	The possibility to press the handle together more when holding a pot is liked by some users	The finger rest was too large and sharp for several users.
Requires less change in grip from open to	Users may place the wrong part on the	Some users find it easier to open and	Experienced as shorter as the finger

closed position	pot first, requiring some more force to close it in the existing design.	close	grip leads many users to take grips further back
Users appreciated the ability to maneuver the handle with their thumb	Some users want a better thumb grip for maneuvering		The small outward bent jaw surfaces in the existing design could cause issues while stowing the handle
Experienced as new and innovative			The side cut outs may cause the handle to be experienced as more fragile than it actually is
Utilising a compact design without protruding parts			It might not be possible to bend into final shape due to the perforated sides
			The hole for the rotation rod could be too close to the edge to avoid fractures
			The smaller jaw contact surfaces might still dent the pot surface

# APPENDIX 12.

## REQUIREMENT LIST EVALUATION

The two concepts fulfill slightly different requirements, which are stated below. A green tick means fulfilled, an orange tilde means somewhat fulfilled and a red cross means not fulfilled. Questions marks are used where the fulfillment is uncertain.

### Functions of the handle

Requirement	Gripslide	Plier
The handle must be able to grip all Trangia pots and frying pans, with curved or rolled edges, small and large, in a stable way	✓	✓
The handle must grip pots tightly, and not slide in any direction	✓	✓
The handle must not obstruct or hinder the user during usage of the pots	✓	✓
The handle must be easy to adjust between gripping and non-gripping position	✓	✓
The handle must be able to grip the windscreens	✓	✓
The handle must be possible to use to adjust the pot holders	✓	✓
The handle must be able to grip an upside-down frying pan without significant obstructions	?	?
The handle should be able to adjust the simmer ring	?	?
There could be a handle with other integrated functions	✗	✗

### Durability

Requirement	Gripslide	Plier
The handle must have a lifespan similar to the other parts of the stove	?	?
A working handle must never fail so severely that it cannot be used to hold pots until replaced	?	?
The handle must not get significantly worse performance over time	?	?
The handle should be possible to repair if damaged	✓	✓

### Manufacturing

Requirement	Gripslide	Plier
The handle should cost less than 5 SEK to manufacture	?	?

### Material damages

Requirement	Gripslide	Plier
The Handle must scratch coatings less than the existing handle during use	✓	✓
The Handle must scratch coatings as little as possible during use	✓	~

The Handle must scratch coatings as little as possible, and less than the existing handle, when being stored in the stove	?	?
The handle must not deform the edges of the pots	?	?

## Jaws

Requirement	GripSlide	Plier
The handle should be able to place onto pots without the inner jaw sliding vertically	~	✗
The jaws should not slide vertically on pots when changing from closed to open position	✓	✗
The jaws should be able to close without causing temporary pressure points	✓	✗
The surfaces of the jaws in contact with pots should be smooth	✓	~
The edges of the jaws should not be entirely sharp	✓	✓
The jaws should not slide sideways when holding the pot	✓	✓
The jaws should be manufactured in a softer material than aluminium	✗	✗

## Size

Requirement	GripSlide	Plier
The size of the handle must fit comfortable in the hands of both lowest percentile and the upper percentile	✓	~
The handle must be lighter than the existing product, 46 gram	~	✓

## Placement

Requirement	GripSlide	Plier
The handle must be easy to locate during usage, even in dim light.	~	~
The handle must be easy to fit within the kitchens, and in kettles for both 25 and 27	✓	✓
The handle should have a obvious placement within the packed kitchen	✗	✗

## Temperature

Requirement	GripSlide	Plier
The handle must withstand the heat generated by normal cooking	✓	✓
The handle must sustain flames from the burner	✓	✓
The handle must not get uncomfortably warm during usage	~	~
The handle must not get uncomfortably cold during winter	~	~
The handle should not freeze shut during winter	?	?

## Physical ergonomics

Requirement	GripSlide	Plier
The handle shall be comfortable to grip and hold for prolonged times	✓	~

The handle shall be possible to use with a soft grip	?	?
The handle shall not have sharp edges that users can cut themselves on	~	~
The handle should be comfortable to hold in both open and closed position	✓	~
The switch between open and closed position of the handle should be comfortable	✓	✓
The handle should be possible to use with gloves or reduced movements	~	✓
Users should not be able to pinch their hands using the handle	✓	✗

## User experience

Requirement	GripSlide	Plier
The product shall be experienced as sturdy when lifting the pots	?	?

## Cleaning

Requirement	GripSlide	Plier
The handle shall be easy to clean	~	✓

## Environmental aspects

Requirement	GripSlide	Plier
The product shall harm the environment as little as possible	?	?
The product should be made in a recyclable material	✓	✓

## Visual brand identity

Requirement	GripSlide	Plier
The product shall bear the Trangia logotype	✓	✓
The product shall visually fit together with the Trangia brand	✓	~

