

ICONIC ARCHITECTURE

*The Booklet*



*a designerly speculation by*  
GUSTAF ELIAS

MAP OF WORK

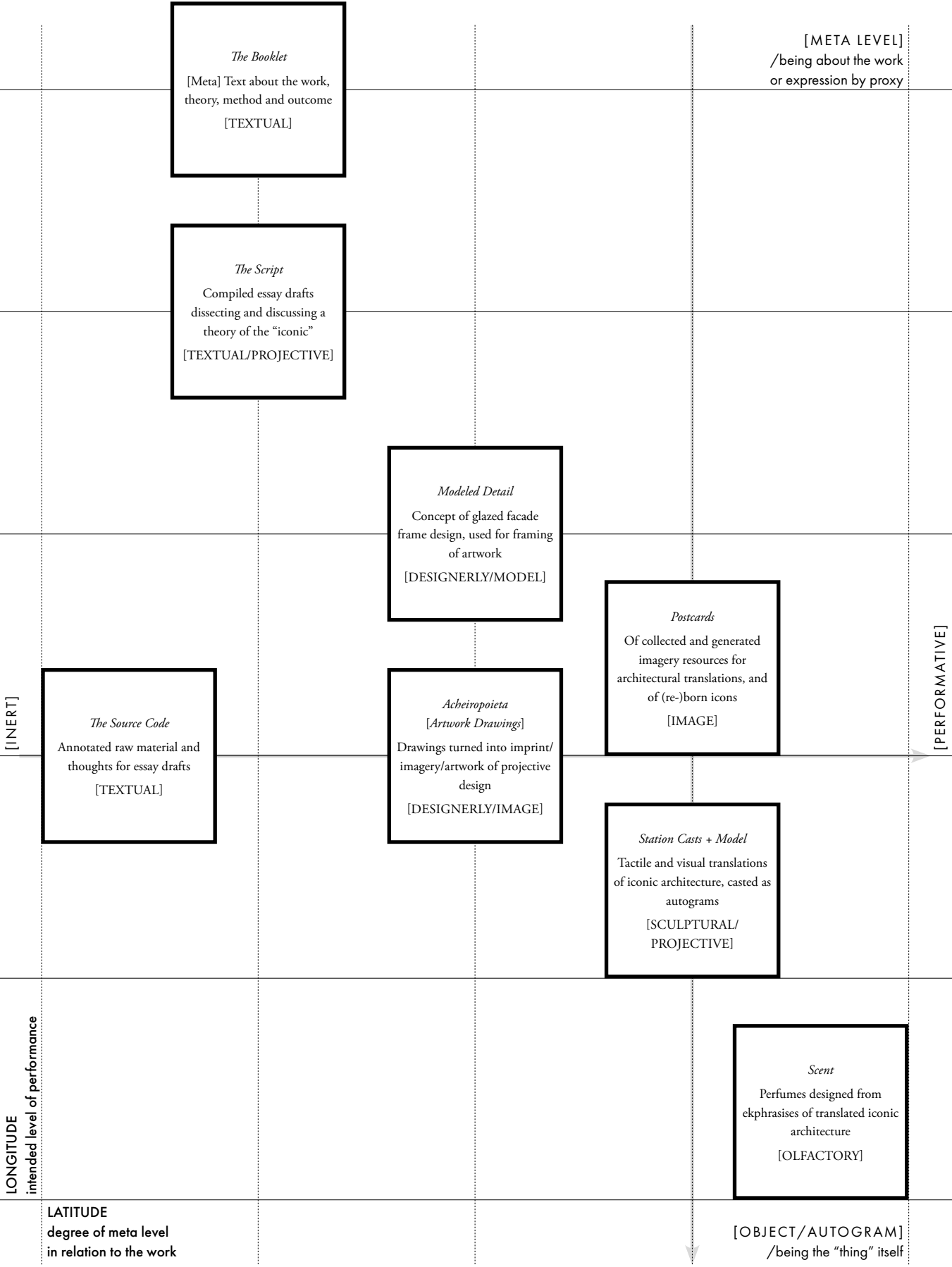

ICONIC ARCHITECTURE  
STATION TO STATION: FROM IMAGE TO VISCERAL  
ICONS IN A GOTHENBURG METRO

*The Booklet*

Gustaf Elias  
Gorthenburg, Sweden  
2025

---

Master Thesis | ACEX35  
Chalmers School of Architecture  
Department of Architecture and Civil Engineering  
Architecture and Urban Design (MPARC), MSc  
Architectural Experimentation: Before and after Building

Supervisor: Naima Callenberg  
Examiner: Daniel Norell, PhD, Architect SAR/MSA



© Author 2025. All rights reserved.

250609-2201



To *Naima*  
for our discussions,  
your eagerness to understand,  
your curiosity and patience.

And *Jarkko*  
for your kindness and help,  
making my iconic and manic visions come true,  
via cnc milled styrofoam and more.

And *Jenny*  
who planted a seed,  
and convinced me there was more.  
We're still a team.

---

 ICONIC ARCHITECTURE

 STATION TO STATION:  
 FROM IMAGE TO VISCERAL ICONS IN A GOTHENBURG METRO

Index	6
Map of Work	2
Proem	11

## PREFACE

## 1. DISCLOSURE

Abstract	19
Conclusion and Spoiler	17
Curatorial Text	20
Keywords	19

## 2. AUTHOR BACKGROUND

Artistic CV	23
Bio	23

## FOUNDATION

## 3. PRELIMINARIES

Metro Stations as Iconic Design and Suspension of Disbelief	28
Objectives and Questions	31
Outset and Purpose	30
Scope and Delimitations	27
The Iconic in a Post-Star Architecture Era	29

## 4. INTRODUCTION

A Wandering Mind	34
Background	37
Intention	33
On the Look for Expanded Visuality	40

## 5. METHOD

Conveyance of Results	47
Dealing with Design Principles	46
Design Principles	45
Expression by Olfactory Means — As the Classic Greeks	48
Four Stages of Glitching	52
From Image to Architecture and Visceral Icon with Scent	49

	Rhetoric Architecture	44
	Two Phases	43
6. THEORY AND CONCEPTS		
	Accursed Share Imagery	64
	An Icon	57
	Collective Aesthetics and Contextual Overload	64
	Concepts and Keys as Theoretical Framework	57
	Hero Images and Connotative Shadows	62
	Iconicity	61
	Image Translation	74
	Interfaced	73
	Modality of Drawing: Proxy, Meta and Autogram	78
	Multi Sensory Amplification of the Iconic	75
	Superposition	61
	The Fantastic, Hineini!	70
	The Iconic Drawing — For Mass Consumption	67
	The Iconoclash	72
	The Prompt	74
		BODY
7. REALITY, DREAM & DESIGN		
	Acheiropoieta	88
	Conceived Space as Image Space	86
	Glitched Homage to Bernini, Borromini and Mies	86
	Gothenburg Metro — A Long Lived Dream and Snake	83
	Metro as Infrastructure and Rendered Art Space	85
	Scent and Listen to the Autograms	89
	Station to Station	86
8. DISCUSSION		
	Architectural Tautology	94
	A Superpositioned Hero Image	95
	Design for the Iconic	93
	Iconic Sustainability	97
	Involution of Iconic Manifest and the Vanishing Point	94
	Sensory Iconic	98
	The Incisive Joke	99
EPILOGUE		
	Epilogue I	101

## CHAPTERS

## ACTS

---

	APPENDIX I	
REFERENCES		
Figures		107
Literature		103
Sources		105
	APPENDIX II	
EKPHRASISES		
The Icon of Classic Antiquity		110
The Icon of High Renaissance		112
The Icon of Modernism		114
Translation from Visual to Visceral Icon		109
	APPENDIX III	
ACHEIROPOIETA		
Final Expressions and Visuals		117
Lavender Line Eau de Parfum x3		128
Lavender Line Postcards		119
Seagram Station Imprint		122
Standing Mies Detail Matrix		127
Standing Mies Model		130
Standing Mies Plan II Squash		125
Standing Mies Postcard Render		118
Stathmós Parthenon Imprint		120
Station Concept Deep Mid		123
Stazione Tempietto Imprint		121
	APPENDIX IV	
FIGURES		
Assembly of Standing Mies		175
Casting of Base Plate for Standing Mies		165
Casting of Concrete Positive Autogram		172
Casting of Slab Tracks 1:87		167
Casting of Wax Negative		170
Compilation of Figures, Pictures and Visuals		139
Concept Station and Platform Design		161
Embellished Station Spaces by Artwork		155
Expected Infrastructural Architecture		154
From 3D Model to Casting Mould		164

Glitched Translation in Stage 3	163
Hammarkullen Subterranean Tram Station	159
Historic Metro Visions of Gothenburg	153
Iconic Drawing of Parthenon	141
Lavender Line Site Map	157
Lavender Line Site Plans	158
Most Recurring Drawing of Seagram Building	148
Parthenon by ChatGPT	140
Parthenon Debossing, Embossing, and Scaling	143
Parthenon Translation and Iteration Sequence	142
Platform Heights and Gaps	162
Post Processing of Station Pit Cast	166
Preparation of positive casting moulds	168
Seagram Building Deboss, Emboss, and Details	150
Seagram Building in reality and by ChatGPT	147
Seagram Building Translation and Iterations	149
Stockholm Metro	160
Tempietto by ChatGPT	144
Tempietto Iteration Sequence I	145
Tempietto Iteration Sequence II: Palladio Plan Extrusion	146
The Barcelona Pavilion to Standing Mies	151
The Lavender Line	156
The Standing Mies Artwork	152

## APPENDIX V

## KEYS

Key 1	178
Key 2	179
Key 3	180
Key 4	181
Key 5	182
Key 6	183
Key 7	184
Key 8	185
Key 9	186
Key 10	187
Recollections	177

## EPILOGUE

Epilogue II	189
-------------	-----



A Note Book Entry

Jag vill förändra en plats  
Kanske skapa den  
Kanske definiera eller dedikera den  
Med arkitektoniska element  
Men mest av allt  
Skapa en rymd för något  
Tänk om endast med arkitektoniska medel  
Jag kunde röra mig i renaste arkitektur

Maybe I'm not interested  
In architecture as the house  
Not even the building  
But as the phenomena  
Could be the home  
Could also be the hall  
Or a bathroom  
Not the tectonic in a sense of construction  
But architecture in the sense of cultivation  
Border-lining the art  
Or the sculpture  
As being something  
There to provoke a question  
To the answer being the design



## First Notion and Message

This thesis is based on real intentions [and relevance] — however certain elements have been fictionalised for dramatic purposes of speculative kind, and implicit effect of spectacular kind.

Because, once suspension of disbelief is reached, some things are not just looked at or heard, but truly seen and listened to, and best believed as stories. So beautifully ignorant, yet simply lured, is the human mind. Never could it resist a touch of drama.

## Second Notion and Message

The first half of the thesis was in large an intellectual work, dissecting and synthesizing literature and other's work, together with ideas and conceptions, along with own textual reflections. Seeking to partly deconstruct the "iconic" concept and result a compilation of thought. These text drafts are compiled in what is called *The Script*. A subsidiary appendix to the final outcome of the thesis. Sections of *The Script* are transcribed for chapters on background, theory and concepts in *The Booklet*.

The suite of work intentionally makes use of aspects and ideas of *layering*, *ambiguity*, *multivalence* and *double coding*. A completely clear conveyance was originally never intended in *The Script*, nor desired. And so is in part the case with the final design expressions. Believing in interpretational power, dynamics and effect in calibrated ambiguity.

Furthermore, the interactor's complete understanding of the theoretical parts is *not* regarded to be of paramount weight. In a meta comment on the contemporary world and our insatiable lust to rationalise most of it, this work recognise the fact that our information flow and experience no longer is to be thought of in a linear or sequenced manner. But in chaos and overload, in an involved performance of all-at-once-ness, fragments of sensation and potential revelation shines through to us in partially articulated forms. *Signals* are merged and sometimes drowned in *noise* in the contemporary world. Therefore, this project doesn't have to be engaged with in a "linear" manner. Rather a provocation of sensation, and, or, of thought, is the prime intention of this work. Especially its resulting outcome.

### Third Notion & Revelation

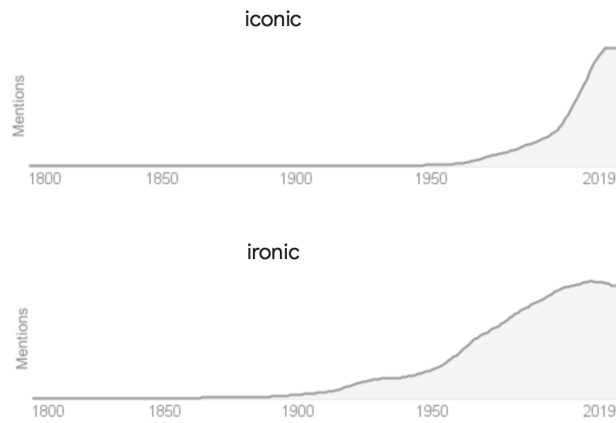

Figure 0.1 (top) and 0.2 (bottom). Word usage over time (data collected from Google Search).

#### Icon

Greek: *Eikon* (image, likeness)

#### Irony

Greek: *Eironikos* (dissembling, feigning, ignorance)

#### Iconic [Ironic] “Architecture”

*-Architecture of Ignorant Likeness* or *-Ignorant Image Architecture*

#### Comment

Both words have had a substantial increase in usage starting about twelve respectively seven decades ago. Thus could be implied that we live, language wise – and some theories and philosophers imply that language is what expresses our world, and even constitutes the boundary conditions of our world view – in an accelerated frequent iconic world that has become increasingly ironic.

## PREFACE

## 1. DISCLOSURE

## Conclusion and Spoiler

The iconic becomes an icon  
when it looks like the image  
of the iconic.

Architecture is image  
since decades, if not longer,  
and an icon is the image of images.

This is what constitutes the icon,  
the superpositioned Hero Image,  
of the collective mind and aesthetics.  
Elusive yet conclusive.

To deal with the iconic;  
You'll have to deal with translations,  
and a dynamic and communicative agency,  
with profound impact on, and affective response,  
from both the material reality,  
and more so the collectively conceived world,  
which the iconic permeates.

The iconic is in the star architecture and landmark,  
as well as in the defining and everyday.  
In anything that is or looks like,  
the most like the expected image,  
or sets a new unexpected norm,  
fit for the chock of recognition.

An icon is a manifest.  
And it may be multisensoric.  
Why not a scent, more direct than a visual.



## Abstract

The ‘**STAR ARCHITECTURE**’ is *dead*, Koolhaas stated in 2014. However, our world is hooked on images, and formed by their re-production, spurred on by a **culture of CONSUMPTION**. As consequence, the image now is the accursed share, an inevitable waste of surplus in any culture of excess. Since long — eventually tracing back to the renaissance and the invention of perspective — architecture has become increasingly more image, to the point of being *it* foremost. Hence, there is a case to state, that even if ‘star architecture’ is rightfully claimed dead, it **DOESN'T IMPLY the DEATH of the ICONIC**.

Quite opposite. In this world, defined by its image creation and consumption, the ‘**iconic**’ is of **paramount cultural relevance**. The icon can be argued being a highly effective type of image, for instance *featuring a high “SIGNAL-to-NOISE ratio”*, coupled with a quality of power. Thus, if the iconic is a key element for architecture’s cultural capital and currency today, why not expand our critical knowledge and projective practice to include it as a focus. Can we *revisit the ICONIC CONCEPT to find new relevance*, suitable for the current day? With the outset in architecture *being* image, design concepts has been tested, following a method of continuous translation and glitching of images. Both as metaphors and physical entities. Resulting in part superficial, part significant, translations from image to “new” architecture, and in part disclosing an iconic nature. Consequently breeding “new” or recycled imagery, and the iconic. The design speculation is set within the frame of the partly real vision of a Gothenburg metro line network.

The thesis started in a dissecting reading process combined with own textual essay drafting, seeking to deconstruct ideas of “the iconic”. Architectural theory was combined with media science, semiotics, visual studies and the multi sensory. Sets of potential design principles were pinpointed. In a second phase the theoretical framework was partially expressed, aiming to **EVOKE discussion and SENSATION**. Including tailored scents as part of an expanded visuality of the iconic. The designs are intended to be experienced as interfaces. They may be read as a conceit and tautology of iconic architecture — as “architecturing imagery”.

## Keywords

iconic; architecture; multi sensory; collective aesthetics; image; interface; translation; metro; infrastructure

## Curatorial Text

### Doften av det ikoniska: Från visuell tolkning till sinnlig upplevelse

Multisensorisk materialitet och sinnliga upplevelser utgör en växande inriktning inom konstvetenskap och relaterade discipliner. Genom att utvidga analysen bortom det visuella, inkluderar detta perspektiv hela spektrumet av sinnesintryck - hörsel, doft, smak och beröring - i förståelsen av konstnärliga uttryck och upplevelser. I centrum står en vilja att utmana visuellt inriktade traditioner och skapa mer kroppsligt förankrade och inkluderande sätt att närma sig konst, design och arkitektur.

De teoretiska grunderna för diskussionen om multisensorisk materialitet har vuxit fram genom influenser från de senaste 30 årens materiella, affektiva och sensoriska ”vändningar” inom humaniora. Här knyts verkets fysiska egenskaper till kroppsliga reaktioner, känslor och rumsliga relationer. Forskningen har visat att sinnesupplevelser är sammanflätade, och att konstupplevelsen aldrig är enbart visuell. Inom arkitekturforskning har de taktila och rumsliga dimensionerna varit mer närvarande, men också övriga sensoriska dimensioner har lyfts i syfte att ifrågasätta den visuella dominansen. Multisensoriska perspektiv har lett till förnyelse inom såväl forskning som konstnärliga praktiker.

Historiskt sett finns föregångare till det multisensoriska tänkandet i exempelvis Wagners idé om Gesamtkunstwerk och det modernistiska avantgardets synestetiska experiment. Inom samtidskonsten har multisensoriska strategier lett till immersiva utställningar som engagerar publiken på fler plan än det visuella. Doftbaserade verk, ljudmiljöer och taktila installationer belyser hur konstnärlig materialitet påverkar minne, emotion och platsförankring. Detta kräver också nya kuratoriella och metodologiska tillvägagångssätt. Multisensorisk materialitet utmanar och kompletterar konventionell konsthistorieskrivning genom att återinföra kropp, sinnliga upplevelser, affekt och rumslighet i analyserna. Förhållningssättet möjliggör en mer nyanserad förståelse av konstens samhälleliga funktioner och kulturella betydelser. Genom att lyfta fram det sinnliga som kunskapsbärande och meningsskapande kan diskussionen bidra till mer empatiska, inkluderande och situerade tolkningar och därigenom öppna för nya vägar i både forskning och konstnärlig praktik.

ICONIC ARCHITECTURE av Gustaf Elias är ett spekulativt och sinnesöverskridande projekt som utforskar ”det ikoniska” genom designexperiment i en tänkt göteborgsk tunnelbana. Genom att tolka tre ”ikoniska” byggnader och översätta dem till tunnelbanestationer - inklusive unika doftporträtt inspirerade av byggnaderna - förvandlas arkitekturens bildvärld till rumsliga, taktila och olfaktoriska uttryck. Dofttolkningarna låter oss utforska platserna på nya sätt. Genom att koppla bort blicken och låta

doftsinnen styra upplevelsen aktiveras dolda lager av sensorisk respons och minnen. Projektet utmanar visuellt dominerade forskningstraditioner och betonar arkitekturens kroppsliga och sensoriska dimensioner. I relation till forskningsfältet multisensorisk materialitet visar projektet hur visuella ikoner kan undersökas och utmanas genom sinnliga upplevelser, vilket öppnar för nya sätt att förstå arkitekturens kulturella och affektiva betydelser.

Viveka Kjellmer

*Docent i konst- och bildvetenskap*  
Göteborgs Universitet

19 May 2025



## Bio



The author, at age thirteen, inspecting the classic model railroad dressed in winter by the Edgar brothers, 1:160, at railway museum in Nässjö, Sweden, 2007.

Gustaf Elias (b. 1994), started out as an autodidact photographer capturing people and emotions on local nightclubs in his early twenties. Today he is a professional photographer, artist, AD, designer and founder of Gustaf Elias Studios (est. 2017). Holding a bachelor degree in art history with visual studies, alongside a bachelor degree in architectural design. His multifaceted artistic practice is reflected in his interwoven Studios, spanning many fields and features. From his passion for music photography, various stage expressions, portraits, photographic stories, fine art and exhibitions. Along with commercial image creation and brand content, videography and film, event and documentary coverage, to art direction, graphic expressions, identity and communication, visual design, and architectural design and photography.

## Artistic CV

### *In selection*



#### EDUCATION

Architecture (BA 2023, MSc 2025) \_\_\_\_\_ 2020-2025  
 Chalmers University of Technology  
 Contemporary Art, advanced studies \_\_\_\_\_ 2019  
 Univeristy of Gothenburg  
 Art History and Visual Studies (BA) \_\_\_\_\_ 2019  
 Univeristy of Gothenburg  
 Liberal Arts \_\_\_\_\_ 2017  
 Uppsala Univeristy, Campus Gotland  
 Economics and Business Studies \_\_\_\_\_ 2015-2016  
 Uppsala Univeristy

#### MERITS

Art Museum of Skövde \_\_\_\_\_ 2018-2020  
 Audience Host and Guide  
 Co-Screenwriter, Stills Photographer, Ass. Cinematographer, AD \_\_\_\_\_ 2017  
 'EISODUS – A Skier's Reflection from a Melting Reality'.  
 Short feature-documentary-film. *Awards:* Winner Stockholm Independent  
 Film Festival; Winner Nordic Adventure Film Festival; i.a.

## PUBLICATION

*Books:*

Iconic Ironic Places: Collection I \_\_\_\_\_ 2020

*Photobook**Magazines/Journals:*

KRITIK [2021, (47), Iconic Ironic Places].

*Other:* Arkitekten, Dagens industri, Opus, Gaffa, Åka Skidor, Kupé, Vi, Fjälljournal, i.a.

## AWARDS

Official selection, IPA – int'l photography awards \_\_\_\_\_ 2024

*One Shot – Searching for Peace*

Top 101 International portrait photographs of the year \_\_\_\_\_ 2022

*The International Portrait Photographer of the Year*

Winner, Black and White Single Image Contest \_\_\_\_\_ 2022

*Black and White Magazine*

Honorable Mention, IPA – int'l photography awards \_\_\_\_\_ 2021

*Category: Fine Art – Collage: Iconic Ironic Places (suite)*

## EXHIBITIONS

United by Music \_\_\_\_\_ 2024

*Malmö Live Concert Hall, Malmö Stad, Malmö, Sweden.* Produced for the opening and welcome ceremony of Eurovision Song Contest.

Brick Lane Gallery, London, UK \_\_\_\_\_ 2024

*'Art in Mind'*

Exposición Colectiva, Madrid, Spain \_\_\_\_\_ 2023

*Galeria de Arte Gaudi*

Art Vienna, Vienna, Austria \_\_\_\_\_ 2022

*International Art Fair, Schloss Schönbrunn, represented by Gallery Gaudi.*

Slagkraft [Beat Out] \_\_\_\_\_ 2021-2022

*Malmö Live, Malmö, Sweden.* featuring female conductors, in a new, convention challenging, and alive aesthetics.

Iconic Ironic Places: Collection I \_\_\_\_\_ 2021

*Public outdoor exhibition, Skövde, Sweden.*



## FOUNDATION

### 3. PRELIMINARIES

## Scope and Delimitations

The thesis primarily takes an interests in the “icon” and the “iconic” from a sense of the word based in: semiotics, visual studies, media science, a multi sensory approach, and architectural theory. It is a synthetisation of a complex, though *not* always nor necessarily complicated, web of ideas and concepts.

The thesis has, from the outset, not opted for a clearly defined nor confined delimitation. The lion’s part of its content, specifically its preliminary and researching texts composited in *The Script* (see **Map of Work**, p. 4), is already said, seen, heard, or written, by others. Though what might add news to the table, is this particular synthesis composed by means of conjunctive reflections and design.

## Icon and Iconic

The work of this thesis set out to investigate, inquire, and explore the presumably grand scope of the “icon” and “iconic”. And do so in a minor scale, without naive belief or intention to understand, clarify, elucidate and claim a universal truth in a complete or definitive way. The work intends to evoke interest and response, and state a tentative claim, or re-state several connected ones. Thus a strict delimitation was initially in the work conceived as being a liability, as much as a potential help. Rather the work has applied a continuous and dynamic self-delimitation of sorts, guided by the progress of the work itself, and the design project with its inherent design choices, delineated and guided by the initial textual work of *The Script* in phase one (see **section 5.1**).

The textual work has most often not chosen to conduct its inquiry straight on. But rather by attempts of partially circumnavigating the topic, and intentionally mishiitting bulls eye. Since the initial conception has been that there already

is a preconceived image or idea of the “iconic”, and if we want to dis-cover something new, or else, we probably better step out of the axiomatic bubble, which most probably would give a biased start. With the intention of potentially get a new or other view of the phenomena from outside, the inquire conducted through the essays in *The Script* are not only *on*, but *about* and *surround* the “iconic”.

The concept of the “icon” is both interpreted in the more obvious sense of *something famous, well recognised, worthy of veneration, landmarking or symbolic, or the often mentioned one*, or the one with *a quality of being able to define places*, et cetera. As well as engaging in a discussion and idea of anything, even the ordinary and *everyday*, having a potential *iconic “side” or “expression plane”*.

The thesis disregards notions of an icon in the sense of an image like symbol in the computer realm or digital world. Neither does it elaborate on the icon as motif and expression in christian image tradition.

## 3.2

### Metro Stations as Iconic Design and Suspension of Disbelief

Ideas and research of the thesis is applied in different modes and expressions of imagery translations of “the iconic”. To give form to three speculative metro stations for the city of Gothenburg. The designs serves as examples and visualisation of the design theory on the iconic.

The stations place themselves as expressions of a speculative design attitude. Neither real economics, politics, or infrastructural engineering is dwelt upon or taken into deeper consideration, since it is outside the scope of the thesis’ core. However, the designs has not completely rejected the claims and aspects of reality. As further presented in **Section 7.1**, the designs connect to a real and live political reality. Particularly the ongoing realisation of the infrastructure project Västlänken. As well as a long lived idea, dream, or vision — a Gothenburg metro system.

Furthermore, differences in various kinds of city railway lines (stadsbanenät), such as premetro and metro, contra tram concepts, has been studied. As well as regulations issued by Trafikverket, on loading and reference profiles of Swedish railways, contra common tram profiles. For instance effecting lengths and heights of platforms, and platform to vehicle gaps. Data which has been taken into consideration in the station designs. Hence, the station designs carry their layer of sometimes wild imagination — to state a point regarding the iconic and image architecture — while putting themselves within a reality case. This in order to enhance the strength of the speculative design, by means of focus on incisive aspects which potentially contributes to a suspension of disbelief.

In essence, the design part is *not* particularly about city planning, infrastructural design, or its engineering. It *is* about the iconic, image, and architecture. Put into a design case commenting on the iconic, imagery aspects of architecture, alongside modes and effects of translations from architecture to image and back again. This while speculatively *giving form to spaces*, set within a frame of infrastructural interventions. Thus, it is real architecture, yet imagery to character. Additionally multisensoric (see **section 5.6, 5.7**).

### 3.3

#### The Iconic in a Post-Star Architecture Era

About ten years ago starchitector (*star architect* and perhaps *icon* in his own terms) Rem Koolhaas, declared the concept of “star architecture” dead (Plevoets and van Cleempoel, 2019, p. 48). Up till this point in time, iconic architecture can be seen to have been a kind of key and prime architecture. Perhaps epitomised, in relation to an image aspect, in the postmodernism epoch, and following through till the time of Koolhaas’ statement. In terms of this historically more recent iconic architecture, it often features a seemingly blatant iconic and image architecture. Sometimes with almost garish conceptual outcomes. Other times intriguing and fascinating compositions, idea challenging work, and stand out expressions. As if the buildings of the star architecture and the iconic, not only of this time in history, but no matter epoch, was labeled almost equally, spurred on and understood through an attitude fed by the contemporary culture. First of all sharing a seemingly common line of causation, and secondly shouting out: ‘Hineieni!’. Where ever they stand.

However, this trend of iconic architecture, and notion of “iconicity”, rests on an idea of the icon being the one standing out. The one carrying the manifest saying, like a king: “I become the manifest of my surrounding”. A manifest Julien de Smedt for instance means he challenges, or inverts, with his design of the ski jumping hill in Holmenkollen, Oslo, from 2011 (Smedt et al., 2017) (See this example and discussion further in **section 6.2**). The past icon we are talking about here, is the one that draws heavily on the idea of interpreting the more literal sense or common interpretation of the word, “icon”; by being the most famous, most popular, most recognisable, and the like. And, or, going back to the ideas of “imageability”. As presented notably by Kevin Lynch (1960), discussing how easily a town or the a conceptual map of a city is conceived by the inhabitier or person roaming the streets. The icons of the past era seems to have followed suite, and urged a imageability making them easily recognisable, and reproducible as image.

An *image*. This is the key concept. Architecture not only as image, but deeply so, as to *become* image; *the image* itself. For instance Arvidsson (2015) dissects

and comments on this, and focuses on how museum architecture from post modernism up till the mid 2010s has been built with a large emphasis on the “image aspect”. Turning buildings and spaces into images, rather than functional or ideal spaces for curation in the case of museums. The point being that this kind of architecture has been intensely focused on attraction making, signal buildings, landmarks, and the symbolism added to the ideas of the old credos in architecture of *form* and *function*.

So if “star architecture” now is dead — is its partner in crime, “iconic architecture”, also dead? The founding position for this work is, No. Correlation is not causation. There has been, and obviously is, iconic architecture from eras before the more recent one mentioned. And the usage of the word “iconic” has increased and is high (see diagram, **figure 0.1**). And no wonder! Since we perhaps live in the greatest image eras and cultures of [image] consumption ever witnessed. The iconic, as this thesis argue, goes hand in hand with the ideas of imagery and a culture of consumption. The greater question is; what meaning do we fill the word with? The iconic remains; but what it implies may change; or get added meaning and layers to it, as time and culture change. So, what is; or could the “iconic” be; in a post star architecture era? Could we extract a set of principles of “the iconic” for “the new era”? And what would such a design attitude, and design work inspired by such a reframed iconic idea, end up rendering?

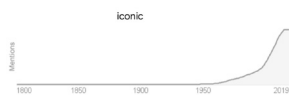

Fig 0.1: Usage over time of the word 'iconic' (data collected from Google Search).

3.4

**Outset and Purpose**

This thesis is an attempt of revisiting the iconic concept and idea, to find new relevance. And explore an improved and elaborated language of the iconic in relation to architecture, and architecture as image. Both the conception of the iconic and of architecture as image, can be seen being of defining and decisive importance today. A recognition of these facts is a crucial key in defining the *why* of this thesis. Used with intent the icon and iconic not only possess power, but *is* power (see **section 4.3**).

However, the thesis goes beyond thinking of the “iconic” and “iconicity” in relation to architecture in a strictly imagery sense, based in terms of pictures and the visual sense above all. But argues for, and attempts, a broader and for our current time and culture more suiting approach to the idea and conception of *image* and *iconicity*. More specifically a multi sensory approach.

The work and its manifestation as a design project aims to create a commentary on the iconic, as well as an implicit theoretical mapping of sorts. (The latter written forth in the part of work called *The Script*, though not presented as a primary result. See **Map of Work**, p. 4, and **section 5.1**.) This foundation

functions as basis for a re-evaluation of theory regarding the “iconic” and “iconicity” in architecture. Furthermore, if possible, it also aims to propose a new and contemporary view and approach in *thinking* “iconicity”, as well as a *practice* achieving “iconicity” (see **section 6.3**) in architecture.

## 3.5

### Objectives and Questions

The thesis question emanates from a remodeling of the statement by Rem Koolhaas from 2014, expressing “star architecture” to be dead (see **section 3.3**). The iconic is not dead though — is the unwritten pretext of this thesis. Reiterated with a keen eye towards the conception of the iconic, and supposedly its high relevance and capacity both in today’s media environment and society in general, the remodeled statement comes out as follows: If the iconic is an enabling element for the architect’s, and architecture’s, cultural capital and currency today, then why not expand our critical knowledge and projective practice to include it as a focus. Hence the main question of this thesis becomes:

(0) Can we *revisit* the *iconic concept* to find a new relevance in its reading and interpretation, suitable for the current day?

Which is broken down into two components:

- (1) What *is* the iconic?
- (2) Can and should we *design for* the iconic?

Furthermore, a third component crystallised itself during the first phase. The textual and theoretical work opened for and encouraged an approach to multi sensory aspects and theories, in the attempt of understanding and re-framing the iconic.

(3) Can the iconic be expressed in an *expanded visuality*, beyond the pure visual or imagery — and gain from such an expanded expression?



## Intention

This thesis has embraced an implicit position of research *for* design. For instance, part of its work has in the theoretical phase one (see **section 5.1**) resulted in the preliminary collection of sets of speculative advice and principles *for* design of the “iconic”, partly tested, expressed and visualised in the second phase, concerned with design and visual expressions.

The suite of work is indeed to be understood as a speculative endeavor, in its founding intention and attitude. In the sense of it not laying claim on a completely rational nor true reality. It has in some parts embraced a position of unreality, partly to observe the reality and world from an external position, one of unreality. As Dunne and Raby (2024[2013]) notes, the speculative approach allows for the work to exploit the freedom of aesthetic opportunities coning from the realm of unreality; by accepting the nature of design speculation, and *not* trying to convince the viewer of any reality claim of the idea. The suite of work and its expressions seeks to provoke thought and induce reflection, by balancing on the tickling edge of reality and unreality.

There is however an inherent problem with this thesis. It has to direct gazes and alter state of minds, in order for its expressions to work as intended. There is a chance of missing the point, if people as they often tend to do, read what became the physical outcome only. Don't stare blindly at the artwork! But try to engage in its meaning. Or complete it yourself; with yourself; in yourself. Problem arise if you read the work as an “excuse” or exploration of a “method” to draw houses in particular, or architecture in general, in a certain mode... In my opinion there is no excuses needed, and there already is a method to the practice of doing architecture and draw houses. Namely to “draw houses” or “engage in pure architecture”... This is another and additional layer.

What I want to do is to understand and express what this practice means, in

relation to when and how something called *architecture* shows iconic quality Or what this something is, when it becomes an icon. The actual architecture featured and designed in this thesis is thus to some degree without specific interest — as to what architecture it is and what architectural qualities it shows, besides being iconic or expressing iconic properties. In this sense the design is to be read as a tautology (See **section 8.2**). In logic referring to a clause that is true no matter the meaning of its constituting parts. Or in language referring to re-saying of something of the same thing as already said.

The design of this thesis aims to be true no matter its constituting parts, and its expressions is presented partly as proxies, as well as meta expressions and key expressions as autograms (see **section 6.15**) of the underlying thesis. It is about a gaze at the motif and the *performance*, or *potential performativity* of the motif, rather than the motif itself. Although neither can be regarded without the other.

But how can I help people being so horny for the motif and concrete expression?! I cannot be responsible for any potentially blind eye of the audience. You see what's out in front of you, at your own risk and perils. It's a sight telling you how your head looks to you inside. I can merely direct gazes and impose realms for interpretation. Your experience is at your own expense.

#### THE ARCHITECT

“Into the museum hall  
I walk and I stall  
Where there's seemingly nothing  
Nothing here to see  
My vision wanders  
In the chambers of confusion  
My gaze just looks around  
So I've unlearnt to see”

I wish I could be Vergil. Finding you, Dante, lost in the forest, tempted by the world with its lures and appeals as they appear to us. To take your hand and guide you down the funnel of the subconscious and sub-surficial. Through a deconstruction of the iconic. To deliver you into a potential realm of new lucidity. Where a design of and for the iconic is both believed in terms of why and suggestive how.

4.2

### A Wandering Mind

*An architectural drawing and revelation by foot and mind in dusk.*

A VOICE  
INSIDE YOUR HEAD

The museum has grown by tradition  
A temple of the eye  
From the Ashmolean in the 1600s  
A room for the objects  
The chamber of ostensive experience  
Centering the eye and thought  
The art we call art  
So long resided in the visual domain  
Of depiction to be seen  
No matter aesthetics  
From natural and concrete form  
To the abstract  
Yet with the eye as converging recipient  
So long, that now  
In a multi sensory turn  
The other senses seems infringing  
In this temple  
With its room refined to suit the eye

The media is the message  
The media alters our sense perception  
So McLuhan said  
The alphabet and text freed the word  
And locked in the world  
When we gave an ear for an eye  
And let the hegemony of the eye  
Urge for quicker visuals  
Give us images  
Make us pictures  
More of the same  
And almost the same  
All that we learnt to appreciate  
Technological innovation freed the picture  
To be created and viewed  
Anytime, anyhow, anywhere  
Flooded us in presupposed content  
In networks of speed  
The outer world came near  
In the mediated images  
You made me numb  
Numbed my crisp vision  
And overshadowed the really near  
In a glocal belief

The virtual life reside  
Next to a modern paradox  
The more pictures the fewer images  
Strong enough to sustain  
Accessibility craves to blame  
And embedded in image storms  
To visual heaps  
The accursed share emerged  
By natural laws of general economics  
We had to consume  
With unreflected gazes in visual rites  
So our world came to be  
An image of what really is  
While the eye was dazed  
We unlearnt to read  
Neither text nor image understood  
But learnt to look  
And travelled with looks all around we did  
But forgot to really see  
And never did we leave  
'Cause in the imagery we were caught  
And all we left was the sensible sight  
For clichés and patterns approved

Into the sensory turn we then trod  
When media changed  
The pods still boom  
And here we stand  
Eyes dazed wanting back an ear  
Or please, please  
Give me only more  
More to feel  
More senses to entertain  
Forget the ratios and perceptions  
More to numb  
Much too numb  
More is never enough  
More is whore!  
More is core and our lore!  
The accursed share to consume  
Till no more resistance to squander  
Into the museum hall

I walk and I stall  
 Where there's seemingly nothing  
 Nothing here to see  
 My vision wanders  
 In the chambers of confusion  
 My gaze just looks around  
 So I've unlearnt to see  
 And in this old temple of vision  
 Once designed for my eye  
 I hear noises sometimes  
 And a performance streams through a screen  
 Sometimes I am urged to smell  
 Or feel my way  
 In these chambers of confusion  
 A room no longer suiting awaits  
 I wanted in  
 To escape the mundane  
 On street level outside  
 But in here, bewilderment stares me down  
 And out there, my escapism awaits  
 In earphones and through personal screens  
 My world evolves in pods and imagery feeds  
 They relieve my steps from cold cobblestones  
 Whose meaning I've lost  
 And past the evergreens and the yard  
 I walk too seek some hope  
 On this grey winter's day  
 Though their meaning seems lost on us too  
 Who still knew the cypress tree connotes death  
 Eternity, grief, and a hope for more than this  
 Pietas now lost in the soft green needles  
 Now only what remains  
 Is their much too blatant reality claim

There is glass and steel on the skyline  
 Bricks and concrete in my horizon  
 An idea from past  
 Now a fact to pass  
 I walk 'round monuments along streets  
 I know most from their images  
 And iconic counterparts  
 My world is now in superposition  
 As a probability function  
 Never real or particular  
 Where was my body lost?

And then is when I hear in my ear  
 How does your head look to your eyes?  
 Well I'll tell you  
 It looks as what you see out in front of you  
 'Cause what's out in front of you  
 Is how you feel inside your head  
 And suddenly, I do not struggle anymore  
 To feel my feelings  
 They appear to me  
 Redundant free

The night at last sets  
 To free my world and vision  
 And then is when I realise  
 Past the threshold of the temple beside  
 The museum of sound already is  
 In the concert hall  
 A room suiting the sense  
 The museum of the act already is  
 In the theatre  
 A room suiting the sense  
 The museum of flickering stories already is  
 In the cinema  
 A room suiting the sense  
 All rooms of visions and dreams  
 Already sitting next to the temple of the eye  
 The old museum of depiction  
 Why let the old room  
 Make the work of the other?  
 As we confused let the new media  
 Do the work of the old  
 And why impose an old room  
 On the function of another or new?

How iconic isn't the room suiting the senses  
 Suiting its senses  
 Suiting itself

I'm a fictitious character  
 I go to the tower  
 Where plan has become section  
 A cut through the sensible  
 A ratio exposed  
 And I go below ground  
 And into my station of unreality

Is it  
 A never realised metro dream?  
 A sculpture and art hall to be?  
 In terms of its own  
 Walls of empty already expressed  
 An icon imprinted  
 A translation debossed  
 A mark of designerly history  
 A new expression in space embossed  
 A room of its own  
 I don't know how you were inverted  
 You were perverted too  
 I don't know why nobody told you  
 How to unfold you  
 While I'm within  
 Where what's iconic from a distance  
 Fades from within  
 Here nothing's to be seen from afar  
 But only from within  
 The iconic is only image  
 Or present therein  
 While I'm within  
 The iconic manifest involution  
 In a subterranean dream  
 Free to move in patterns  
 Yet nothing touches ground

4.3

## Background

### A Culture Hooked on Imagery

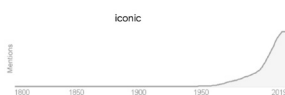

Fig 0.1:  
 Usage over time of the word  
 'iconic' (data collected from  
 Google Search).

“Icon” comes from Greek: *Eikon*, meaning image, or likeness. In data collected from Google search engine it can be seen that the word has had a substantial and exponential increase in usage starting about seven decades ago. Thus could be implied that we live, language wise — and some philosophers and theories imply that language is what expresses our world, and even constitutes the boundary conditions of our world view — in an accelerated and frequently iconic world.

Our world is hooked on and formed by image and a culture of consumption, in which the iconic plays a prominent role. Even if the ‘star architecture’ might be rightfully claimed dead, as by Koolhaas (Plevoets and van Cleempoel, 2019, p. 48; see also **section 3.3**), that doesn't necessarily mean the iconic has to follow suite. Rather, in this world — of visuality for credibility, interconnectedness, vast

amount of the in-substantial and superficial, multiple reality claims, all-at-once-ness, image consumption, and increasingly “empty branding” — the *icon* and *iconic* could be stated being of paramount cultural relevance for the architect. Images are power; showed already in the times of Gaius Octavius, becoming the first emperor of the Roman Empire as Caesar Augustus in 27 B.C.E. Who executed a strategic and successful political campaign driven by clever usage of imagery (Zanker, 1990). The icon, as image, is coupled with even more power (Bergström, 2020).

### Architecture is Image

Furthermore, it could be argued, and has been so, that architecture *is* image. The visual language is one of the most prominent and important ways for architects to express the imagined, their design and visions — hence the practice of architecture, becomes a practice of creating images. And thus, to adopt and adapt a visual language, and by such means use images a critical statement for example, is a way to be “heard” in and through architecture (Maya, 2018).

Arvidsson (2015), who analyses the development of modern and contemporary museum architecture, claims that it showcases an idea of highlighting the image aspect of itself. Architecture is image today, and museum architecture not the least has been increasingly so for decades, if not half a century — or even longer, dependent on how we look at it and define it. Not only the more spectacular, complex, and sculptural architecture, emphasising ideas of symbols, landmarks, branding, consumerism and commercialism, and not the least of being both visual and spatial attractions, shows this intent or inclination — but the minimalist and new modernist buildings as well. Both camps are not expressing a functional oriented, nor any other pure ideology foremost, but an aesthetic reason becoming an almost self-righteous expression. Image has become part of the function and aim, and form and expression part of the value making. If anything, this is the pure ideology. Turning the building into an ornament itself — likewise, and no matter aesthetic style or ideology. Subsequently turning architecture into image.

Dal Co argued in the 90s that the architectural drawing had become a vehicle for something else, and most importantly, of its own (Decroos, B. et al., 2020).

There is “[a] complete idiotic attitude of our era towards drawings, an attitude we invariably find in the magazines, where, since it is in fashion to reproduce and print images, numerous pages are dedicated to drawings by architects, with the intellectual justification that they are autonomous” (Ibid, p. 13).

Dal Co expressed in 1992. A distinct image practice of architecture that can be traced, although with different intentions according to Dal Co, back to the renaissance (Ibid). Which historically coincide with the discovery of the *vanishing point*. From invention or discovery by the renaissance artist and architect Brunelleschi about 1415, onwards, McLuhan (2008[1967]) means it has fostered and nurtured the idea of beholders, and mainly placed us “outside” looking in or on the world and its representations.

It may be argued that the fashion industry has come further in its language and communication to the consumer and user. As one person who has some experience from working in the fashion industry in Sweden expressed it in a private conversation on aesthetics, style, and trends. It could however further be argued that architecture possesses another kind of complexity, especially longevity; than fashion design, as in clothes and apparel design. But with the statement on fashion in mind, and acceptance of the fact of being in the argued culture of consumption of present day, two attitudes towards architectural design could be proposed: To believe it is time to put up a resistance towards kinds of fashion design attitudes and sentiments, as well as faster or less complex design statements. Or to assume and subsequently accept the fact that this culture also regards architecture, turning it into a kind of fashion as well — imposing new conditions. Both positions become a positive relational statement towards the fashion design attitude, acknowledging its existence. A negative position on the other hand is of no help.

The point being, that whatever positive attitude chosen, it becomes an acknowledgment of the fact that architecture needs to develop a better language and establish a more direct, perhaps visceral, communication with the consumers and users, as fashion has done more successfully. And thus regard the consumers not as passive recipients of architecture, but as actors in the network. An actor network theory then becomes relevant to apply on architecture. As well as regard the “thingly” nature of architecture rather than its “objective” nature, which Latour and Yaneva (2008) speaks for.

Hence, can we afford *not* to acknowledge and acquire knowledge of the iconic, its processes and performativity, as part of the thingly nature of architecture? Supposedly, such a knowledge of the iconic enhances our language and communication of architecture to all relevant and co-creating actors within the network; the expanded and moving context of the architecture.

### Contemporary Day Condition

The idea of revisiting the iconic, to find new relevance and potentially extract design principles for the iconic, engages in a cross disciplinary approach. It builds on an idea of acceptance of contemporary day conditions. In this idea

architecture is conceived as entangled with, for instance, the concepts of imagery, media, and ratios of sense perception. Not only autonomous units of physical and concrete tectonics. The thesis still though acknowledges that architecture inhere concepts, expressions, tasks and aesthetics that is its own — dealing with pure architecture. However, the thesis do not believe an understanding of the iconic can be set exclusively within this realm.

The thesis still does not want to fall short to what Latour and Yaneva (2018) accuses some attempts dealing with of architectural theory and context of doing:

“As long as we have not found a way to do for buildings the reverse of what Marey managed to do for the flights of birds and the gaits of horses, architectural theory will be a rather parasitical endeavor that adds historical, philosophical, stylistic, and semiotic ‘dimensions’ to a conception of buildings that has not moved an inch.”

Ideally the results of this thesis’ work can see to the “thingly nature” of architecture, and its iconic aspects specifically, more than an “objective” aspect. A view promoted by Latour and Yaneva.

#### 4.4

### On the Look for Expanded Visuality

When the “iconic” is mentioned or discussed, most people think of visuality and imagery aspects or effects. As architecture *is* image, the iconic is per definition and axiomatically thought of as image. This thesis has, however, incorporated an attempt to look for an “expanded visuality” of the iconic. This in order to find a more “direct” visuality fitting the contemporary times characterised by speed, short attention spans, and all-at-onceness.

The more images our culture devours in its consumptive urge, the more importance the *one* ends up bearing. The *one* defying immediate consumption, or promoting sustained consumption. Consumption thus sustains the icons being *one* of the selected ones. The sustained message in the “Mess Age” (as McLuhan [1967(2008)] called it), is carried by the icon, be it as elusive or conceptual, yet permeating and defining, as a visual identity may be. A visual identifier that may be visual beyond its visuality by look or gaze, and regard olfactory or auditory properties as well. Anything fitting the culture of speed and consumption. We are here talking of an *expanded visuality*. The icon being the most prominent identifier, and owing to its iconicity, the known actor in the network as well as agent of the communicative message, in the “Mass Age” (as McLuhan [Ibid] also called it).

Though contrary to our visual urge and consumption, in the 60s McLuhan stated that:

“At the high speeds of electric communication, purely visual means of apprehending the world are no longer possible; they are just too slow to be relevant or effective.” (McLuhan, 1967[1996], p. 63)

It comes across as an almost counterintuitive statement, since we seem to read images much faster than we process text (being our widely used information source otherwise); and since our world seems more visual centric and “supermarket of images”-influenced than ever. Yet if our culture is affirmative of McLuhan’s claim; then what does it mean, for architecture, and for the icon? Perhaps other forms and ratios of sense perception. A new form of “visual perception” is needed. Multi sensory with emotional and instinctive “visuals”. The icon has a potential to carry this. It has to fully become the visceral icon.



N.B.

This is *not* a method of iconic architecture. Not a suggestive method as a result of the theoretical work in the first textual phase of the thesis. This chapter presents how the thesis was conceived and conducted.

5.1

## Two Phases

A description of the overarching process of the intellectual work of this thesis, can be abstracted as follows; in tow main phases, and four main steps:

### *First Phase:*

Mainly a textual and literature bound intellectual work. Engaged in an own textual drafting process of essays. Which regards also the processing and reiteration of text as a design drafting process, able to generate a textual architectural drawing of sort.

(1) Posing of question: Is there an unwritten manifesto or compilation of principles of the iconic? Which relates to our society and ongoing culture. A culture of consumption and imagery.

(2) Attempt to write a kind of manifesto (*The Script*). Conducted through the drafting of dissecting and circumnavigating written essays; containing reflections and discussions on different approaches and thoughts on the “icon” and “iconic”. Followed by a compilation of sets of principles and advice summarising a potential and speculative guide for design of the “iconic”.

*Second Phase:*

From pinpointed leads and extracted design principles of design *for* or *of* the “iconic”, recognised in the first phase, an “architectural” design is conceived. This design is intended to in part “visualise”, “illustrate”, model, prototype, or put into picture, the outcome of the first phase and work — the deconstruction of “the iconic”. This by a intention of *sensation*. “Visualised” should here be interpreted in an expanded notion and sense, not only focused on a eye-centric idea, but in part utilising a multi sensory approach.

If the first phase is to be seen mainly as an *intellectual* work, the second phase can be understood more as an *visceral* work. Aligning to the ideas of “emotional design” (see **section 5.5**; and *The Script* for further reflection and discussion on this particular topic).

(3) Posing of question: What if we were to design, without much further restriction, according to the principles and theoretical framework from (2)? That is to say, design an eventual extreme of this proposed manifesto. Manifesting the theory in a design that partly visualises some of its aspects set in a case. This by means of implementing ideas of the iconic, as well as ideas of modalities of expression and representation; design by *meta*, *proxy*, and *autogram* (see definition and discussion on the modalities in **section 6.15**).

(4) Performative realisation and exhibition of expressions, visuals and design results. Make it interact with its surrounding and audience. Not only be a passive visual presentation.

*Attitude:*

The attitude of the design is speculative, and works with a realm of unreality, while partly being set within a serious context of reality (as described in **section 3.2** and **4.1**). Or rather, of *what could be*. Hence, it is part real in intention, although part fictitious in expression, with the *iconic* as a sub text.

## 5.2

**Rhetoric Architecture**

The design process is in its foundation conceived and arranged using the concept of classic Greek rhetorics: the theory of *Partes*. Abstracted as follows:

*Inventio* ... Creation of a compiled source material. By means of cross reading and dissection of texts on the topic of the icon or iconic; or work, texts, concepts and ideas,

circumnavigating the topic. Parallel to the reading was the process of writing the essay drafts, which are supposed to environ the topic. The raw form of essays became a pool of content, or stream of consciousness and reflection. Thus becoming the environment of the thesis, with its design project and potential expressions.

*Dispositio* ... Pinpointing and extraction of potential leads and design principles from the source material, also called *The Source Code*, to form condensed manifest of the iconic. As well as structuring and editing the raw essay drafts into a compiled document and piece of work called *The Script*.

*Elocutio* ... Conceive a design to be executed as manifestation of the principles, ideas and concepts, delineated by *The Script*.

*Memoria* ... A perceptive design is produced, or modeled and represented as an expression, that can be experienced. Evoke sensation. Using the idea of design as proxy, by model or manifestation of result in previous step.

The design work intends to acts as an *aphorism* and/or *tautology* of the intellectual textual work and theoretical framing. It is in large to be perceived as a kind of incisive paper architecture, rather than a probable or complete design proposal to be implemented. The intention is not primarily to be executed or built, but to provide a room for thought. To emphasise a collection of thought, and evoke own reflection. Thus become the manifestation of a work conceived in large as an attempt of research *for* design.

*Actio* ... Presentation by publication, performance, exhibition.

## 5.3

### Design Principles

MARSHALL MCLUHAN

“Our time presents a unique opportunity for learning by means of humor — a perceptive or incisive joke can be more meaningful than platitudes lying between two covers.”  
(1967[1996], p. 10)

The deconstruction of the iconic in the first phase made use of this attitude proposed by McLuhan, when it resulted in its set of potential and speculative design principles. Intended to guide design choices in attempts of “design for the iconic”. If internalised, they may also contribute to form a good and affective design intuition as well.

The principles were divided into four categories, based on their theme and its respective level of abstraction from a concrete design expression. Ordered from the more principal and abstracted principles, to the more pragmatic and direct projective, they are as follows. To be read and implemented interchangeably:

(1) *Gestalt Psychology*

The five founding principles in visual discernment, based on satisfaction of the six sub- or unconscious primal desires and urges.

(2) *Speculative Design*

Based in Dunne and Raby’s (2024[2013]) speculative design attitude.

(3) *Iconic Notion*

Based on the leads found in the so called *The Source Code*, which is the raw essay drafts, and their compilation in *The Script*.

(4) LIVE (Multi Sensory Approach)

Inspired by Bruce Mau’s set of principles for multi sensory design and art expressions, presented in “Designing LIVE: A New Medium” (Lupton and Lips, 2018).

Here in *The Booklet*, these sets of principles will not be further presented or elaborated upon. They are to be regarded as preliminary work for the design outcome and final expressions of this thesis and its suite of work.

## 5.4

### Dealing with Design Principles

The preliminary design principles of this thesis are proposed to be treated, and were so in the design of the second phase, in accordance with the attitude towards design principles presented by Tufte (1983). In his discussion on a theory of visual display of quantitative information he states what is key to all design practice: “Design is choice”. His theory follows the idea that design principles are to generate design options and guide the choice amongst them. However any design principles should not be applied with “rigidity” or in a

“peevisish spirit”, as Tufte expresses it. Rather: “Most principles of design should be greeted with some skepticism, for word authority can dominate our vision, and we may come to see only through the lenses of word authority rather than with our own eyes.” (Ibid).

This is likely to be the case of a possible, pragmatic, and in a sense useful design theory of the iconic as well. That is to say, an aesthetic theory of conception, address, and expression of iconicity. If there are principles to discover for such a theory, and if the ones extracted from the essays may be regarded as such, they will be design principles generating options, and supposedly utilised to inform a judgment, and potentially guide choices. They should, as Tufte (1983) states for his design principles, not be thought of as mathematically or logically true, nor as definitive principles in all instances. At best they can discover a discourse of the icon and iconic beyond the authority of word. Preferably also beyond a visual centrism in architecture. As such they aspire to be “designerly” oriented.

## 5.5

### Conveyance of Results

The design results and presentation material has had the intention in part to strive for what Tufte (1983) so aptly puts as main goal in the design for mediation of information: “What is to be sought in designs for the display of information is the clear portrayal of complexity. Not the complication of the simple; rather the task of the designer is to give visual access to the subtle and the difficult — that is, the revelation of the complex.” However, the presentation material also intends to comment on the nature of its underlying complexity, by means of not hiding layers of complexity. In this way also be a mirror of the presented and proposed result of the icon and iconic, being a layered phenomena with potential complexity that is lobotomised by processes of hollowfication and superficial notion of the iconic image. Hence, the work in part also makes intentional use of ideas of *layering*, *ambiguity*, *multivalence* and *double coding*.

The presentation works with its results and its mediation both as *meta* re-presentation and as *proxy*, as well as producing *autograms* (see **section 6.15** for an elaboration on these concepts). That is to say, both making the point by being the point made in a self-referential manner, and by expressions acting on behalf of the point made by means of re-presenting the content as proxies. As well as becoming the expression itself, and be in essence non-referential except to itself.

In this sense the presentation has opted to work with layering, believing chaos and complexity in plain sight in itself can carry a clear message, without having to be “read”, and is as an effective tool as simplification, clarification and summary. It is the combination of expressions, redundancy, and layering that intends to achieve a revelation of the complex here. If wanted, it may just as

well be engaged with as mere [stunning] images with superficial appeal. After all a design is but a design. Experienced viscerally, as well as on a behavioural and reflective level. And according the ideas of *emotional design*, a thing or design that looks, and feels good, work better (Norman, 2004). It may still mean something, even when it seemingly means nothing, or the meaning is obscured.

Furthermore, ambiguity as a potentially effective designerly tool and principle, highlighted by for instance both Vignelli (2019) and Zumthor (2005), is utilised in the presentation as a *stimuli*. Both for curiosity and to open patches where a human subject, that is to say the audience, may lay its own claim on the interpretation.

## 5.6

### Expression by Olfactory Means As the Classic Greeks

*The Scripts* lays forth a theory, discussion and reflection, on how the pure visual may be argued too slow for our current day culture; infused with speed, interconnectedness, all-at-onceness, chaos and non-linearity of information flows (commented on in **section 4.4**). Thus, an alternative approach towards “iconicity” is proposed, which speaks for involving more senses in the experience and conveyance of the iconic. More fit for the current culture and times.

One such expansion would be to incorporate olfactory aspects in the mediation of the “iconic”, or a design’s “iconicity”. Smell is argued to be a much faster sensation and evocation than sight (Lupton and Lipps, 2018). (See **section 6.14**)

To comment on these ideas, this thesis has worked with an olfactory approach in its design manifestation of its underlying theory and discussion, developed in *The Script*. The intention being to manifest the idea of olfactory aspects in relation to iconic architecture, by probing a concept of finding a “scent-image” or profile of an iconic architecture. Or by means of priming a beholder or interactor of the iconic architecture with such a profile. This in order to test or show an intention of how an expanded notion of “iconicity”, beyond a strictly image based meaning of the word, could be intended, conceived and executed.

The models of the design results of this thesis — made as casts of leveling compound or self-leveling concrete — both represents existing iconic architecture, while being “new” architecture. Made from the translations of iconic drawings and AI-prompted iconic imagery, of three historically important iconic buildings, from three distinct and defining architectural historical (style) epochs respectively. The casts of these translated and reinterpreted architectural designs were primed with designed scents. Made as perfumes for each architectural translation respectively (see **section 5.7, 7.7**).

The priming of sculptural pieces, which we may think of as primarily visual entities, with scents as in this thesis work, is not really a “new” or novel concept. Research has shown that already the old Greeks, as the saying goes, primed or perfumed their sculptures (Brøns, 2025). Adding, or rather revealing, yet another layer to or of the white myth of antiquity. Since before, the discovery of polychromic expressions of temples, reliefs and sculpture has already busted the modern era white myth, believing in the classic antiquities pure all white expression. By history said to be emanating from Johann Joachim Winckelmann in the 18th century. Sculptures of antiquity were thus not only colorful, but had scents to go along with them, expanding their experiential dimensions. Although antique scents are hard to research due to their obvious elusive nature, modern day technology has given new insights; “particularly gas chromatography-mass spectrometry (GC-MS) and liquid chromatography-mass spectrometry (LC-MS) as well as proteomics and metabolomics, have placed the study of ancient smells within the grasp of modern science” (Ibid). By analysis of lipids, aromatic plants and their residues, hints of the classic scents has been given, and facilitated potential recreations of them.



Fig A12-14:  
Lavender Line Eau de Parfum x3.

The scents designed for the (sculptural) architectural design of this thesis are made with only natural scent components, just as the classic sculpture perfumes. No synthetic components, otherwise often common in modern day commercial perfumes are utilised here.

## 5.7

### From Image to Architecture and Visceral Icon with Scent

Three key eras or epochs of Western architectural history were chosen for the translation work and reinterpreted architectural expressions in three key designs. From each era one iconic or key building were chosen, to be translated architecturally and described by one ekphrasis receptively for translation into different media. The buildings chosen are not only to be seen functioning as icons and testimonies of the architectural era in which they were conceived; but can be argued to also have had paramount impact on other buildings in the same era, and served as inspiration and resources material for succeeding era’s development of their styles and architecture.

#### Ekphrasis as Intermediary

An ekphrasis is a literary work, which function as a description or commentary on a work of art. It often has a vivid expression, and may be dramatic. In antiquity the word carried a wider notion and used to denote a description that could be about another person, object or experience, though today it has come to denote the literal genre in itself (Dictionary).

For the purpose of this thesis, the ekphrasis was used as a lively, sensory, and poetic description and intermediary translation tool of the architectural icons to be interpreted as a visceral icon in different media, besides the purely visual — by other artists and creators in collaboration with me as architect (see **Appendix II**). The ekphrasis became a core component of the multi sensory approach in the work of this thesis. Used to design the perfumes and soundtracks of the three architectural key designs respectively.

### Three Key Eras

The chosen eras or epochs were: Classic Antiquity, (High) Renaissance, and Modernism.

Much of the Western World architecture can be found tracing back to the architecture of classic antiquity, in that sense a fountainhead. The renaissance was a "rediscovery", resurrection or revival, of classic ideals and thinking. And modernism was in turn distancing from the directly preceding era and ideals. It held an optimistic belief in the now and the future, adopting a linear rather than a circular view of time, and was in large and experimental and critical project, with a desire to evolve the world into the better (Honour, and Fleming, 2009; Fazio, Moffett, and Wodehouse, 2013).

In Sweden the manifesto *Acceptera*, in essence describes the mood of the modernistic architecture from the Swedish perspective. In 1931 the director of Svenska Slöjdföreningen, Gregor Paulsson, together with five merited Swedish architects, all participants in the Stockholm Exhibiton 1930 and part of the Swedish modernist architect movement, jointly wrote the book and manifesto *Acceptera* (Asplund, 1931). Among them Gunnar Asplund, Uno Åhrén and Sven Markelius. The book wanted to debate and was propaganda for the style and concept of "functionalism". The introduction which was also printed on the original cover read:

#### ASPLUND

“Acceptera den föreliggande verkligheten — endast därigenom har vi utsikt att behärska den, att rå på den för att förändra den och skapa kultur som är ett smidigt redskap för livet. Vi har inte behov av en gammal kulturs urvuxna former för att uppehålla vår självaktning. Vi kan inte smyga oss ur vår egen tid bakåt. Vi kan inte heller hoppa förbi något som är besvärligt och oklart in i en utopisk framtid. Vi kan inte annat än att se verkligheten i ögonen och acceptera den för att behärska den. Vad som är medel och vad som är mål i våra dagars kulturliv har det aldrig varit någon

tvekan om. Det är de trötta och pessimistiska, som påstår att vi håller på att skapa en maskinkultur, som är sitt eget ändamål.”

[~Accept the present reality — only by this do we have the outlook to control it, to get the better at it in order to alter it and create culture which is a convenient tool for life. (...) We cannot sneak out of our own time backwards. Nor can we jump past something difficulty and unclear straight into a utopian future (...)]

Though the modernism seemingly wanted to break with the old, and in large rejected ornamentation or decoration, it worked with concepts of beauty, proportions, harmony, and a keen eye to materiality, both aesthetically and functionally. It could thus be argued to pick up ideas from classic antiquity, but on its own terms and for the purpose of the “new” and contemporary age.

### General Image for Visual Translation



Fig 1:  
Parthenon, general and iconic image by ChatGPT.

In order to work with a general “image”, or common idea of which buildings are the most era defining, most “like”, and “most” iconic, ChatGP has been used as a tool. With the argumentation that this kind of AI motor will generate a supposedly common or generally agreed upon knowledge, or “view” on the icons and the iconic. ChatGPT has been feed with seemingly simple questions as prompts, asking for “the most iconic building of [a certain named era]”. The chosen key buildings, form the output of ChatGPT, has resulted in the following line up of main icons. For the spatial (architectural) design interpretation as metro station spaces (cavities), their visuals, scents (perfumes), and sound (ambient tracks):

(1) Classic Antiquity — *Parthenon*, by Iktinos and Kallikrates, Athens, Greece, from ca. 430-450 BCE.



Fig 7:  
Tempietto, general and iconic image by ChatGPT.

(2) High Renaissance — *Tempietto di San Pietro in Montorio*, by Donato Bramante, Rome, Italy, ca 1502. ChatGPT primarily proposes two other buildings: Firstly, Santa Maria del Fiore, Florence. With the first western cupola built after the roman antique period, drawn by Brunelleschi; often held as the “inventor” of one point perspective, which was an important invention of the renaissance, having had paramount influence on succeeding eras. Secondly, Saint Peter’s Church, Rome, drawn and built during centuries, and featuring several influential renaissance architects; among them Bramante, Rafael, and Michelangelo. However,



Fig 12:  
Seagram Building, general and  
iconic image by ChatGPT.

with Tempietto a new phase in the renaissance architecture begins, where Bramante returns to classical proportions and aesthetics. For instance the correct implementation of the classical Greek orders; and also rejection of what he saw as unnecessary or irrelevant ornamentation. Furthermore Tempietto is a building from the midst of the High Renaissance. All in all making it a key renaissance icon.

(3) Modernism — *The Seagram Building*, by Ludwig Mies van der Rohe, accompanied by Philip Johnson et al., Manhattan, New York City, 1958. This is a later modernist icon, epitomising a visions of modernism in a Skyscraper. And being an icon of the “International Style” as well.

For the architectural design of one entrance situation above ground an additional icon is chosen for translation and reiteration:

(4) Modernism — *The Barcelona Pavillion*, by Ludwig Mies van der Rohe, Barcelona, Spain, World Fair 1929.

## 5.8

### Four Stages of Glitching

An effect appears when a radio receiver with loud speakers is moved into a room that before was silent. Suddenly we will become aware that this silence previously only existed on a certain frequency. That we, in fact, all the time shared this silent space with sound waves from an Ukrainian radio station or the nightly calls and chatter of some taxi drivers (De Botton, 2021, p. 33). This is what this thesis, and more so its design expressions sets out to do. Or rather *be*. Be the radio, disclosing the radio waves that were there all along. Be a reveal of the frequency of the sound of silence. Be the glitch, a friction in the flow, that visualises a non-visual structure of the consumable and “superficial” part of the image, which is the figurative and intended readable layer of the meaning of the message, the visual representation. In this way will the concept of the “iconic” as well as the imagery aspect of architecture be deconstructed.

According to Grundell (2016) — conducting a case study of glitches in the flow, particularly studying how photo-based glitch art affect the spectatorship — the protocols of the underlying system of the digital environment and our interfacing with it is often hidden. The “flow” is so pervasive, stable and natural, that on an everyday basis it appears axiomatic these days. Thus there is a naturalised integration process of the individual and system. Though, Grundell means that glitches in the digital environment creates a kind of *friction* that

makes visible the digital flow, which otherwise “is often trivial and abstract enough to be invisible.” (Ibid, p. 9). The icon is not alone. It is *the one*. It is *within*, and because of, the protocol, operating seamlessly integrated and covert. Singling it out and credit it as such.

The icon is, or becomes, not without a system. “Iconicity” may be a quality inherent within the icon candidate itself, though the iconic and the *icon* as such is better regarded as a property being *without it-self*. The icon as such, may thus be a loose affiliate, though pointing to a specific entity, or the idea of it.

Can the iconic, or rather the process of icon generation, be visualised and dis-covered or unveiled by means of glitches somehow — by working with glitches of sort and thus creating the friction in the axiomatic flow of the icon? In a paper titled “Drawing the Glitch”, Austin and Perin (2016) lays out a well referenced discussion about the “nature”, or rather un-naturely prospects, of digital drawing and drafting. Along with what constitutes the glitch and its relation to the architectural drawing. Instead of viewing the glitch just as a malfunction or erroneous effect, they discuss how it as “accidental potential” act within digital imagery. A kind of “potential” that is entailed in all innovations, as exemplified by Virilio:

#### VIRILIO

“The innovation of the ship already entailed the innovation of the shipwreck.” (Ibid)

And they themselves state that:

#### AUSTIN AND PERIN

“Algorithms look after the translation from user input to its visual representation in the design process.” (Ibid)

Hence the renders of a design process becomes implications of this. One being that the visual representation of an image is only its “surface” — the visuals. While other forms of expression constitutes its “structure” — in essence being the digital code, along with coding and decoding protocols, Austin and Perin notes.

#### GAULON

“The digital glitch [...] is a way of seeing the code behind a document.” (Ibid)

That is to say, laying bare the structure and go beyond the surface of the imagery. Much like Grundell (2016) refers to the glitch as a “friction” in the flow, laying bare the underlying, Austin and Perin (2016) refers to the glitch as a “resistance”:

## AUSTIN AND PERIN

“The glitched drawing resists the drawing’s material and spatial notions to be decoded via the allographic rules of the drawing.”

The process of the experimental practice in this thesis, translating the image of four classic icons into new spatial situations, and bringing the image of selected icons back into [iconic] architectural designs, inherits defined stages of potential erroneous mistakes. Though, as noted above, we may not only see them as “erroneous” — there is expressive and disclosing potential in these potential flaws. In a way they deconstruct the “iconic” idea, image, and architecture, by designerly and architectonic means:

*First* — by algorithms. When an iconic conception or collective *image* is translated into *a picture*. That is the translation of each building respectively made by ChatGPT via prompts in this thesis work. And by the selection of one of the most common and recursive drawings, of the chosen iconic building or one of its details, which is appearing as result from a simple Google image search.

*Second* — by me, the architect; a human subject, eye and mind. When the image and drawing is translated into a 3D modeled interpretation of the picture, in turn the image.

*Third* — by machine. When the positive casting mould is milled by a CNC machine, having only a certain tolerance and drilling tools set up. In this case, for instance, fine details will be lost from the original digital model.

*Four* — by stages of casting and material characteristics. When the models are casted in a reinterpreted method of the classic lost-wax casting process (Cirre Perdue); the oldest know casting method, dating approximately 6500 years back in modern day Bulgaria, and was notably also used in the Mesopotamian region during the third millennium BC (Honour and Fleming, 2009). Here a three stage process of positive→negative→positive. With each material, foam(XPS)→paraffin wax (or silicone)→self-leveling concrete, all will interfere with the translation process by means of their materiality.

Every step of the way in the iconic translation process in this thesis’ design work eats away on the renderings of details, their exactness, and even resemblance with “reality”, or an intended iconic original. For example, in the “iconic



Fig 12:  
"Iconic image of Seagram Building", render from prompt in ChatGPT.

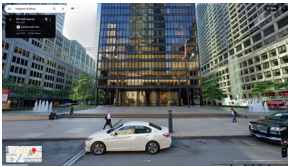

Fig 11:  
Screenshot from Google Maps of actual situation of the plaza in front of Seagram Building.

image" prompted forth via ChatGPT, and used as original for the translation of Seagram Building, a mirror pond is rendered in the enlarged plaza in front of the building. In reality the Park Avenue lies much closer to the entrance and there are two minor mirror ponds to each side instead. The concept of the building and design ideas of Mies van Der Rohe's architecture is rendered "correctly", but composited slightly erroneous or glitched.

The method and model making process of the thesis becomes a metaphor, or even similar representation of the process in which the superpositioned (see **section 6.4**) iconic image of the collective mind is constantly reiterated and recreated — as exactly *that* it; but in an inexact an unreal, yet defining image. The new original becomes the image. While reality becomes a replica of the image. A hero image, all as much a phantom or ghost image (see also the discussion in **section 6.5**). The image is not distanced from reality, but reality somewhat from the creating and mediating "flow" and its rendered icon or "image". Any attempt of likeness or resemblance with the iconic, and subsequently the original, must stand the test against this hero image, rather than reality. The chock of recognition!... these days, will appear in reality, when faced with the real original, looking like the image.

This work thus embraces *glitches* that may create disclosure or "friction" in the "flow", and expose underlying structures of the surfaces of images. Learn your own tricks — though it often turns out to be the hardest thing you'll ever do...



## Concepts and Keys as Theoretical Framework

The part of work called *The Script* presents, comments and discusses several concepts, leads, and found “keys” in a revisiting and re-framing of the icon and the iconic, as well as for a speculative attempt of design *of* or *for* the iconic. The reflective essays in the *The Script* serve as a theoretical background and subtext providing a theoretical framework of the design outcome, expressions and visuals of this thesis.

The following is a short-listing of concepts and keys of the “iconic”, figuring in the essays of *The Script*. Chosen with regards to the selective focus on the concepts most prominent in the design phase of the thesis. *The Script* presents too wide a scope, or set of ideas and concepts for design of the iconic, to be manifested or expressed in a design within the limitation of this thesis. See also **Appendix V**, with visuals and diagrams of selected concepts and keys.

## An Icon

### Looking like it

In a semiotic sense one could speak of a sign having three levels: the top being the syntactic (its visual appearance), then the semantic (its content), and finally the pragmatic level (its aim, effect, and function; and what it does to us, its performativity). This essay takes interest in all levels.

Charles Sanders Peirce, one of the pioneers in semiotics, who’s ideas of a theory of signs have been influential, presented a definition which differentiates the *icon*, from *symbol*, and *index* — all being types of signs (Liszka, 1996). The icon is special in the sense of being the most resembling, or “look alike” expression

of everything that looks like *it*. Or of which the icon has become a symbol or representation of. So by saying that the icon is different, we are partly right, but also wrong. Indeed it is special, but the way in which the icon differs is by epitomising all the others, or that “other”, which it is said to look like, and hence differs from. It differs since it is more of it, than all others of the same kind. It is so much of the same, or so alike what it attempts to be like, that it or its “image” ends up *becoming* what it resembles — it becomes *it*, an *icon*.

The icon is the most, of precisely it. It thus needs a kind of clarity, but too much or disclosed makes it risk being flat, lacking and banal. Too clearly defined could also make it locked in and harder for some to create a subjective interpretation in order to bond with it. It may gain from a precision of vagueness, as we shall see. However, what the concept of being most tells us, is that to become an icon doesn't necessarily have mean being something spectacular or very special or even extreme, but indeed the most of something. Much enough to be representative of a potential or actual rest. Be it, being the most of a certain characteristic, or most recognisable of a certain feature, most memorable of the same type or kind, or the like... Let's call it having the most *iconicity*, or the strongest or *most fit imageability*. Within this iconicity and imageability also lies what the dictionary definition states as “worthy of veneration”. If the icon candidate is not the most, it must at least fulfill the condition of being fit for veneration. So in a first instance of this reasoning an icon can only be an icon of something. But in everyday talk we also use the phrasing icon as a stand alone expression and thing. Sometimes without the of being implicit. We talk or refer to a kind of self-referential icon. The indeed different icon, set free by being so much most of all, and distinctly so, that it is iconic of itself. The icon candidate can in this the second instance of reasoning become an icon if it also fits the second condition; being fit for veneration.

Even a seemingly “ordinary” house can be iconic, if it looks the most like an “ordinary” house (see **Key 3, Appendix V**). The “monopoly house” is iconic of the typical idea or conception of a conventional or typical house. If a child, in the Western world, were to draw a house it would most often look a special way — just like a house! Our preconceived idea of a house as expressed in the collective aesthetics of our culture and cultural groupings. The explicit image fits the collective inner mental image, the overlapping communicational interpretant.

Thus, in a pan-iconic culture and time, all architecture, even the everyday architecture, can be argued to have an “iconic side”, plane, or expression. “Side” as in a literal sense as well as in a figure of speech. This iconic side can be thought of as an iconic quality or aspect. The “side”/quality/aspect through which the architecture identify itself, and can be identified just as its particular architectural design. This by being *like* the “image” of itself or its particular design. Leading to the state of recognition.

## Delineator and Thing of Devotion

A seemingly superficial pop-magazine-article titled *The 25 most famous buildings in the world to visit before you die* in Elle Decor, from 2023, starts with asking: “So what makes a building fit the definition [of being iconic]?” The former chief curator of architecture and design at the Museum of Modern Art in New York City, Barry Bergdoll, answers:

‘It has to be one that’s immediately recognizable to a vast number of people whether they’ve seen it in person or not, (...) It should, on its own, define a landscape or place.’  
(Curkin and Mulvey, 2023)

However, in the same article Bergdoll is quoted: “(...) iconic buildings are not specific to one period or place. They are borderless ‘things of devotion’.” (Ibid).

Hence, the icon is in one sense place- and context-less. This is the threat of hollow-ness posed by the icon, as well as its strength. But if we are to look to, or perhaps *for*, a physical context of the icon, there is an implied manifest of the icon. Which both Bergdoll and architect Julien De Smedt are onto, namely:

The icon manifests, or becomes the manifest of the surroundings (Curkin and Mulvey, 2023; Smedt et al., 2017).

But there are cases in which the icon does invert this concept of itself. As De Smedt says about his own design of the ski jumping hill in Holmenkollen, Oslo. Where “the surroundings become the manifest”, for the icon. Here, not the least by means of the visitor platform atop where one can take in the Oslo fjord, the mountain hills, and the region beyond (Smedt et al., 2017). At the same time, the icon’s context in a wider sense, is not specifically place bound. Since the icon *is* image. The icon is as Bergdoll said a “borderless thing of devotion”. So if we want to situate the icon, as icon; or review its context; it is equally well done within the collective mind, and its environment. Which is carrying and creating the image. That is, to situate the icon among its actors and in its networks, its “thingly” environment and place.

## Modern Versus Contemporary Icon

The writing on museum architecture by Arvidsson (2015), was touched upon already in Chapter 4. *Introduction*, stating that architecture is image today. But this claim also opens up for a proposed change in framing and understanding of the icon today, contra past time.

Arvidsson speaks of how key aspects of form and structure of the Modernist era, was amended by ideas of symbolism and the sign by the Postmodernism movement. Not the least by the seminal writing of Venturi and Scott Brown in *Learning from Las Vegas* (1977). In a post-war and commercial context they study and highlight the expression of American architecture in relation to its function and content of the building. They distinguish between two types of building expressions: “the duck”, being architecture expressing the content of the building by designerly form, which often complicates the aesthetics as a result; and “the decorated shed”, being generic, principle or simpler architecture and construction, expressing content and function by billboards.

However, these types don't seem to take us closer to a conclusive definition or design principle of iconic architecture. Both types seems relevant for iconic architecture today seeking landmark or symbol status. Though, in the culture of consumption and media environment of today, architecture is image; and in many senses detached from concrete reality. For the architecture intended to “sell”, it is supposedly more effective to *icon mark* or *imprint* a building, and doing so by cunning imagery and culture creation, than to search for and express an elaborated aesthetics and designerly form. *Gimmick* has become a more important publicity device. Hence, both the decorated shed and the duck could work. Though, the decoration is not a billboard but an imagery iconic imprint, and the duck is best served as fast food in the hunger for consumption. If fine dining, it must have direct visual and visceral appeal, to be consumed by the eye before taste.

However, more yielding here is the implied amendment by the postmodern spirit, of ideas of *symbolism* and the *sign* to architecture. To Arvidsson (2015) this amendment is key in his reading of the expressed focus shift in the architecture he comments on. From the modernist idea of transparency, unity and the ideal of “form follows function”; to the development of the museum architecture we see today, which has embraced an imagery aspect and function. As result of the postmodern renegotiation of architecture, going from being about form, to being about signs. Resemblance with modernism in today's architecture is therefore rather on a visual plane, than an ideological one. If modernism is read from its functional ideal and program. The imagery aspect replaces an older or other ideal, and the buildings become image, is the argument of Arvidsson (Ibid, p. 158). His reflections are based on his study of museum architecture of today and its historic development. Museum architecture, as he points out, has become closely related to branding, landmarks, symbols and attraction. To be traced in some extent to the workings of the concept coined as “late capitalism” by Fredric Jameson, and commented upon by Rosalinda Krauss. In essence stating that the idea of industrialism has entered realms previously disparate from it; such as the arts, with an increased focus on branding and marketing as result (Ibid, p. 166). Hence, museum architecture makes for relevant examples in discussing some aspects of the iconic in architecture. Even when it does not regard a museum

specifically.

What could be implied by this is that, in simplified terms: If the modernistic architecture conceived its icons based on an ideal of *form follows function*. The contemporary icons; in the wake of postmodernist influence and the ideas of late capitalism; conceives its icons based on the sign, surface and branding, by means of image, in what could be stated as *form follows branding* (or marketing and image).

## 6.3

### Iconicity

The property of “iconicity” is held by an icon. The recognition of it can be assumed to rely heavily on pattern recognition today. The iconicity is here interpreted as the object’s, architecture’s or design’s ability to be imagined or turned into an image. It thus share much common ground with the concept of *imageability*, as the one Kevin Lynch (1960) presented for cities. Here iconicity also accounts for the ability of this image to be contained, retained or preserved across communities and human subjects’ interpretations, [aesthetic] taste, and communication. As well as upon abstraction, reduction or permutation of the formal properties of the image.

Since we are talking about a property of an “imageability” of sorts. That is to say, how clear a mental image may be re-created, re-presented, re-remembered, in a human subject observing, remembering or evoking the primal object. It supposedly makes it interesting to study iconicity in a Kevin Lynch-like case study; deconstructing “iconicity” and its “imageability” by means of “pattern recognition”. However, this is beyond the scope of this thesis.

## 6.4

### Superposition

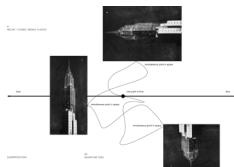

Key 10:  
Icon in superposition. See  
Appendix V.

The iconic architecture is; in some cases, instances and situations; in what could be described as a state of *superposition* (see **Key 9-10, Appendix V**). With a concept inspired by and word borrowed from quantum physics. The icon is oscillating between the conventional “concept of the icon”, where it becomes the manifest of its surroundings, and the inversion of this concept. It is a function of probability, until it is observed from a certain [physical] viewpoint or [mental] standpoint, when it becomes one of the states more certainly.

## Hero Images and Connotative Shadows

The icon can further be described as a *hero image*. A layered, overlaid *and* composite image, though appearing as *one* self contained picture, both complete and defining image entity. A hero image in the contemporary and mainly digital flow is definitive, concrete and collectively shared, yet elusive and not fully static. It is also superpositioned, as is the icon.

Some aspects of this is in part highlighted by the Canadian Centre for Architecture. The museum and research centre in Montreal issued a quite spot on manual titled “How to: not make an architecture magazine” (Borawski, Z. et al., 2018), with a comic yet serious undertow. The manual was published online as an article of a workshop dated 17 august 2018, as the result of an intense period of twenty-one interviews resulting in a manual for what to consider before starting, producing, and publishing an architectural magazine. Commenting on the role and conditions of the architectural magazine, or in these day, more so the wide spread mediation of architecture and architectural projects, defined by the shift towards immaterial media. Two interesting points to note from the manual are as follows:

*Firstly*, in a research from 2005, Columbia Laboratory for Architectural Broadcasting (C-LAB) was looking into what was the most distributed media of printed architecture, and disclosed it was the printed and circulated Euro bills. Physical money that is! — with motifs portraying historical architecture. It would have been the most widespread images of architecture — and consequently, one could argue, the most iconic... The CCA manual proposed a revisit of such a study in our new era of social media influence. In a photomontage the manual superimposed and merged the top most viewed images on social media of Le Corbusier’s iconic modernist Villa Savoye. The house from the year 1928-30 is a built manifesto of his architectural ideas and five principles. The montaged image reveals a kind of “Hero image”, as the manual states, of this iconic piece of architecture. The striking, and wacky thing, is that the superimposed individual images are ghostly identical — showing the building from almost equal perspective and with conspicuous, yet not surprisingly, identical image composition. Striking that is, to the very high degree of *sameness*. Yet not surprising, with regards to the pervasive nature of collective aesthetics, emphasised by means and workings of social media, along with our image consumption.

*Secondly*, the CCA manual almost comically shows how little value text has ended up with. They state that the project of the Norwegian National Opera and Ballet in Oslo from 2008, by Snøhetta, is (or at least was) one of the most viewed architecture projects online. However, a review of the text often published along with images of the project, is more or less identical copies of a

press-releases. More so “poorly-edited”, as the CCA manual states and shows, by superimposing published texts upon each other, and with overlays annotated with textual, grammatical, and own editorial corrections made to the texts. Words simply doesn't seem to mean that much any more.



Fig. A1:  
Standing Mies as hero and cover image. See Appendix III.



Key 4:  
Connotative shadow? See Appendix V.

The point being: A hero image is more effective and affective than text. In some sense self sufficient. Text becomes no more than place holder and content less marker or pointer. The hero image is collectively conceived and iconic of its referent per definition. Furthermore it functions as a cover image. Such an image iconicity will make it less susceptible to only immediate or ephemeral consumption, but be subject to a kind of sustained consumption. All related imagery or picture entities, by context for example, or serial images of the cover *one*, will put on the cover's iconicity and gain their general iconicity from the cover image's, and thus partly or completely suppress their own latent or particular iconicity. In this sense the iconic cover image literally *covers* the rest and becomes the hero image.

In this thesis the cover hero is alluded to in the *acheiropoieta* expressions, especially the postcard rendering of the *Standing Mies* (see Fig. A1, Appendix III).

Iconic “cover architecture” works in the same sense and by the same means. The latent iconicity of a city's individual parts are suppressed by its iconic entities covering the city. Individual parts become contextual content; either divested (deprived) of its iconicity; or with iconicity by inheritance as in an iconic bleed (or glow). We may talk about the major icons working by effect of iconic *connotative shadows*. Note how such a shadow may amplify or cancel out the iconic. Potentiality also creating pseudo-icons (see Key 4, Appendix V). There seems to be scales in these workings, dependent on what scale the iconic entity is conceived at. In this sense, for example, the whole of a city's or city part's silhouette may become the iconic entity on a large scale level.

#### STATEMENT

The single image is dead!

Our culture promotes the composite image or sequenced images (as in motion content, or even the carousel gallery). The overflow and lavish consumption breads what we could call *the pleonastic image* [composite/-ion], in a false reassurance of plenty and sufficiency. Value of the single image unit is rendered by the composite entity or totality.

Compare this idea with the mosaics of earlier art historic periods; today manifested in the digital image with its pixel arrays; as symptomatic of, even influencing and altering[?], the whole image cult today. Or with the example of the “hero image” of Villa Savoye, shown in the CCA “manual” (Borawski

et al., 2018). Or in the concept of photogrammetry, where each picture is made *without care* for “proper” or “good” image creation. Since these kinds of image making principles nowadays, in these kind of image practices, are short-circuited. And since ever single image unit has become a picture unit, never intend to be a single image entity, but part of a totality. May it be the cover image, or hero image, for instance.

Hence, the single unit is rendered valuable by the totality or collective; and the single image, with value of its own, exist only as a masked composite, or virtual render. Which equally well could be named “iconic allographic virtual renders” (plural) [of the collective input/data/information]. Which in turn exists in the mind of the human subject as well as in the collective mind. Thus specific, yet not completely defined. Every unit can be said being *iconic*, in the same way every allographic virtual render is iconic, when it has a convincingly and recognisably enough resembling *likeness* with or of the “mother” render, or its collectively created and conceived composite.

## 6.6

### Accursed Share Imagery

Our technological advancements have resulted in a multifaceted world, with a multitude of reality claims, where data and imagery is as well resources, as assets, and commodities. It is a world that produces, or rather generates, great amounts of data and imagery. This seemingly inexorable surplus of imagery is by necessity — according to the implementation of the principles of the general economy, as laid forth by George Bataille (1991[1949]) in *The Accursed Share* — being consumed and lavishly squandered to a degree of vast extension.

As resource the imagery enables [re-]generation and spreading of collective aesthetics. As assets the images are not directly consumed, but function as input in a seemingly productive practice, often with rather instant subsequent consumption. As commodities the images are most often prodigal products destined for sumptuous consumption. In our networked world characterised by high interconnectedness and plethora of digital platforms and realms, the circulation along with the consumption of the images is more intense, instant, and profound than ever before. The high degree and rate of circulation also enables the taste of the group to become an even greater group, within an even shorter period of time. Quicker and more volatile vogues are to expect as a result. This is the foundation of the collective aesthetics of our day and age.

## 6.7

### Collective Aesthetics and Contextual Overload

Collective aesthetics is here to be related and compared with Baxandall’s (1988)

idea and theory of the “period eye”. By use of the “period eye”, Baxandall situated the renaissance art, and our art historic gaze of it, under the influence of its original context — meaning the cultural conditions of the time in which it was created, viewed and understood by its contemporary actors — artists and beholders, among others. In essence, understanding the art by means of understanding it along with the people and influencing cultural factors of its own time of conception. He meant that people perceive, interpret and understand, in essence *process* art in their brains, in slightly different ways. By means of a combination of innate — inherent or instinctive — and experience based skills. Cultural factors and conditions, the environment of the brain and human subject that is, thus influences the characteristics of art, or expressions, that come across as appealing under certain periods in time.

Hence, Baxandall’s theory gives us an idea of the workings and forming of a collective aesthetics. An understanding of an aesthetics that is in one sense subjectively shaped, oriented and regarded, yet at the same time describes and gives rise to a mutual understanding or agreement of taste of a greater group of people. A collective aesthetic judgment we may say, which can be “thingly” observed and described.

The essence and a major point of our current culture and world, with its collective aesthetic is: !!! . It comes with, as well as being fed by, a **contextual OVERLOAD**; being reality, sensory, cultural, informational, and data bound. Or as Latour and Yaneva (2008) puts it, “‘context’ is this little word that sums up all the various elements that have been bombarding the project from the beginning”. This contextual overload has had an impact.

Zumthor (2005, p. 16) makes a reflection in a chapter called *Beyond the sign*; “Everything merges into everything, and mass communication creates an artificial world of signs. Arbitrariness prevails.” (...) This world of arbitrariness is the reality for the icon. It’s an elusive “environment” of reality, we live in, with a hegemony of images — full of world views, misconception, memory and forgetfulness...

#### SOCRATES

“The discovery of the alphabet will create forgetfulness in the learners’ souls, because they will not use their memories; they will trust to the external written characters and not remember of themselves... You give your disciples not truth but only the semblance of truth; they will be heroes of many things, and will have learned nothing; they will appear to be omniscient and will generally know nothing.”  
(Plato, “Phaedrus”, ~370 BC, dialogue between Socrates and Phaedrus, quoted by McLuhan [1966])

## NARRATOR

Imagine you are on a train, looking out on the passing land-, or cityscape. What is it that you look at? And how does this differ from what you see? If you at all do see.

More so, how does this that you potentially see, differ from what you perceive? These, “visual perceptions”, are not the same things are they?... “The world is full of signs and information, which stand for things that no one fully understands because they, too, turn out to be mere signs for other things. Yet the real thing remains hidden.” (Zumthor, 2005). This is the case, along with our artificial photographic view of the world. In which every individual with his/her aesthetic judgment, though primed and trained collectively in an visual mainly photographic mass psychosis, re-presents only what is perceived and agreed upon to be visually pleasing. In line with Sontag’s (2008[1978]) statement that we see photographically, and what is perceived visually pleasing is what most often comes out visually pleasing in a photograph. Or should we say *satisfactory*, according to Meynell’s (1986) vocabulary.



Key 6:  
TTL-seeing? See Appendix V.

We have adopted what could be called a TTL-seeing; Through-The-Lens (see **Key 6, Appendix V**). With an acronym borrowed from how many modern day cameras measure light and acquire focus. Thus, reinforcing the visual minority of places and icons for example, over the totality of the actual and natural reality. Most places are not photographed... yet the whole world still is to be seen in photographs or by other visual means... a paradox... with probable explanation in the fact that the not-photographed is assumed or assessed to be looking like the rest that is valued highly enough to have become photographed, or it be of no interest or visually un-satisfactory. We make the rest of world beautiful and satisfactory, or ugly and unsatisfactory, by believing in it and its images and that it is... just like that.

Hence, we act and create collectively through our images, formed by a collective aesthetics. Although “we” believe in, or operate in, a culture celebrating individuality, uniqueness, and the emotional subjective imperative. That is to say, it’s probably more of a “dividual” than “individual” process and world we are involved in as human subjects. McLuhan (2008[1967], p. 68f) put it as: “Print technology created the public. Electric technology created the mass. The public consists of separate individuals walking around with separate fixed points of view. The new technology demands that we abandon the luxury of this posture, this fragmentary outlook.” And as this collective or “dividual” mass we are constantly curating and screening the world to neglect the perceived ordinary or mundane, the thought to be non-visually, in a satisfactory sense.

Vignelli (2019, p. 68) said about typefaces:

“As I said, at the time, if all people doing desktop publishing

were doctors we would all be dead! Typefaces experienced an incredible explosion. The computer allowed anybody to design new typefaces, and that became one of the biggest visual pollutions of all times.”

In the culture of consumption we are experiencing a similar visual pollution on a much grander and all pervasive scale. And all the concrete buildings are no longer saying, but *dying*; ‘Hineini, Hineini, Hineini’. This as a happening in an-other kind of “Sub-Ville Radieuse” (in the [visual] “radiant” sense) within the greater imagery “Métropole Radieuse”. Where an ever increasing visual competition and pollution is fed by the consumeristic urge...

As it gets easier to produce visual fragments, more and more makes less sense, and naturally a drop in quality is expected, if the material is not curated(!). The visuals gets polluted, and as a response(?), or rather an adaptation(?), to “the new world order”, consumption along with a dumping of more complex content becomes an answer, making it easier to disregard quality and prefer quantity, even urging it...(!) Thus an evolution, or devolution of the visual perception, is under way... Instating not only new means of visual interaction, but linked to it, also new means of visual generation. Social media is another example of how a new technology and medium accounts for new visuals, and the availability of it accounts for its explosion and permeation in the culture. Comparable to the computer’s explosion of fonts.

All in all, **this is contextual OVERLOAD**; a redundancy of information, expressions and impressions. As a result expressions have to be simplified and repeated — they are bound to, by our actions and systems for the masses. The masses don’t have the interpretational power to decode the messages and inner meanings otherwise. Due to a textual as well as partly visual “illiteracy” stemming from, or implied by, as well as enhanced by the *overload*. (See the essay on *The Society of the Illiterate* in *The Script*.)

## 6.8

### The Iconic Drawing For Mass Consumption

In the Kröller-Müller Museum 1992, the Italian architecture historian Francesco Dal Co holds a speech at the opening of the exhibition “De Ruimte Verruimd” (Space Extended), featuring work of renowned world and star-architects. Dal Co goes on speaking how there up till that day has been two types of drawings: *The modern architectural drawing*, developed during the renaissance, and being dominant up until the early 19th century. When *the contemporary architectural drawing* enters the scene, and perseveres through the upcoming two centuries — through the École des Beaux-Arts, and the modernist era of the 20th century, to be sustained also in the post-modernist time. Which is proven by the drawings at

the show in the museum in 1992, in the national park of Hoge Veluwe, outside of Otterlo.

The former drawing, *the modern*, which Dal Co exemplifies with drawings of Brunelleschi, shows a practice where the drawings were means to discover universal truth. This by their occupation of tracing proportions, taking the measures of things, and formulating the numbers they were ruled by, all in a wish to order and understand the underlying classical universe. While the latter drawing which Dal Co speaks of, *the contemporary*, is in his view, on the contrary, relates to the idea of the new — both of being new and producing new. A notion of beauty in this type of drawing equal to an ever changing and varying idea of the new. We may even speak of vogues.

#### DAL CO

“On the one hand, architecture is something that is able to find truth; on the other, it is something that produces objects meant for consumption, simply because they are new.”

(Decroos et al., 2020)

Anyway, Dal Co doesn't seem overly appeased with either of the two types of architectural drawings he has defined so far. The former since it merely is a conveyor of classical truths; and the latter since it, by lavish publishing, pushes the drawing towards an autonomous notion, which Dal Co means pushes it in to the domain of painting. His critique is that this undermines the drawing as a specific instrument in the architectural design process. Instead an “idiotic” attitude reigns, where drawings are praised as images, he means (see also **section 4.3**). Perhaps the border lining manic image creation and translations of this thesis are to be read as part of the incisive joke (see **section 8.7**), which the work intends to bring about. It is left to the reader to decide and conclude.

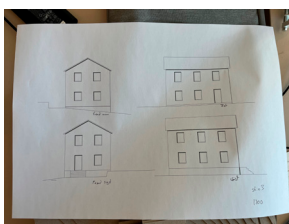

Key 3:  
An everyday icon? See Appendix V.

The drawing is pulled out of its notion as a precise tool, and pushed towards the realm of picture, and in a world of consumption subsequently towards becoming *the image*. Hence, the architecture exists in a double nature; as mediated image, and as reality. However, in the cult[-ure] of image consumption which we live through, one can argue this isn't quite true. Rather the counter intuitive double nature is perhaps closer to the truth. That is, architecture as: *real image* and *mediated reality*. The “imagery notion” of architecture, the image of most icons for example, comes first, then the built actuality. The real has to look like the image to look-a-like, not the opposite. And this might not be that far removed from the truth even for less “known” or “popular” architecture in the iconic sense. Even the *everyday icon*. A house looking like a house for instance (see **Key 3, Appendix V**).

How does *newness* and *consumption* relates and interacts with the idea and

conception of the *icon*? We live in a society, a culture and time of image production, consumption and *waste*. In marketing there even exist a concept called *planned obsolescence*, implying that products are not made to last longer than a certain time, often made shorter than the materials and components actually could sustain, in order for the product to be replaced soon enough, keeping the sales and consumption in constant motion. Likewise our icons, or at least image, should probably also be looked at in this light, as something to be “consumed”. So how does the icon deal with the concept of being, and continuously becoming, new — refreshing itself, and keeping itself relevant for the “consumers”? Or is the Icon, part of a stranger consumption pattern, more or less incapable of depletion?

Perhaps the lesser icons can't deal with this, and thus fade. They will hold their *iconicity* “visible” or “recognisable” when looked at or interacted with, otherwise “invisible” or non-existent — and they'll fail to be sustained Icons. While the sustained ones, are this because of, and as long as, the masses keep feeding itself with new, or seemingly “new” content of the Icon, and thus prevent the depletion of it. This would imply that the iconic property if treated right, is something unable of depletion, but it has to be re-fed into then system and spectacle, to be continuously “visualised”. And not be “over-shadowed” by something “newer” new, or more “*iconic*” iconic.



Key 7:  
An iconic drawing? See  
Appendix V.

The fashion house Suistudio did a campaign 2017 called “Not Dressing Men” (see **Key 7, Appendix V**). It was not about architecture nor architectural photography. However, the fashion/advert images can be used as inspiration for a case study commenting on the two types of architectural drawings Dal Co (Decroos et al., 2020) speaks of. In the shots women with white and black skin color pose enticingly face to camera, dressed in classy suits, in what looks like minimalistic and contemporary furnished skyscraper apartments. In every shot there is a completely naked man, well trained, but always facing way from camera or with their head cut away by something in the frame. The men becomes part of the interior. Passive pleasures for the dominant woman.

These could be renders or provocative architectural photographic work. Scale figures that become so strongly evocative that they potentially steal our focus from the architecture. The women are what Kemp (1998) would call “focalizers”. One of the five forms of address in an image, according to him. With these strong focalizers in place, the architecture is over-shadowed. Thus the images could become comments on the role, argument, function, and intention of architecture. A mere backdrop for the human being, or the strongest focalizer?

This imagery connects to the idea of the contemporary architectural drawing — images to be published and “consumed”. If we were for a moment regard this imagery as architectural imagery. They would present some kind of extreme of this contemporary drawing. No longer even being about architecture, but

its potential or eventual actors. “Sex sells”, as the saying goes, why not also for architecture? By means of a provocation or stimuli, as in these images, an architectural drawing or image could potentially attract attention and sustain an attention span for the “other” in the image, being the architecture, to actually be considered. May be subconsciously.

Though, what makes these fashion shots particularly interesting in this analysis is the existence of naked men. The naked male bodies, stripped of personality, become reminiscent of “The Vitruvian Man”. Leonardo DaVinci’s drawings, from 1492, featuring notes in mirrored text. In this reading it is a flirt with the *modern drawing* as well, with its obsession in the order of the classical universe. Measure things with the body and tracing proportions.

However, viewed as a type of “architectural drawing”, these images become examples of “the incomplete drawing” — utilising *ambiguity*, which both Zumthor (2005) and Vignelli (2019) points out as key factors in good and intriguing design, as well as *indeterminacy* which is an other of Kemp’s (1998) forms of address. Perhaps this type of proposed drawing is closer to a subtype, or third type of drawing, namely *the iconic drawing*. One not afraid to overshadow some of the concrete or “actual” architecture, and regard it more “thingly”.

Especially the postcard renderings and visuals, of the acheiropoieta of this thesis (see **section 7.6**), makes an attempt and comment on being the iconic drawing of mass consumption.

## 6.9

### The Fantastic, Hineini!

In an interview with Christopher Beanland once:

ZAHA HADID

“I remember visiting Berlin in 1995 to see Christo’s Reichstag wrapping ... that’s when it became clear to me that people are very interested in fantastic projects — those projects that make fantasy become reality.” (Beanland, 2021, p. 81).

This speaks for the icon and the iconic-urging architecture. The iconic is more than just a visual property or quality. This is true for the everyday icon as well as for the ambitious and extraordinary iconic architectural vision. In the latter there is a point of even searching and utilising the *civic drama*. “Place the civic centre where maximum civic drama might be achieved.” As Kenneth Brown is quoted in the introduction to Hubert de Cronin Hasting’s *Civita* 1971 (Ibid, p. 7). It seems given to find a reciprocal relation between the icon and the civic

drama, the one potentially inducing the other. Triggering the punctum, with a word borrowed from Barthes (1986), that may transform the vision into an icon. The iconic, as well as the drama, might as noted above, in fact not be part of the “actual” object, design or architecture itself, but its “image” in an extended conception. Is it a performative and latent aspect, that is about how to append, affix, awake, appeal and extend? Whatever, never could we resist a touch of drama...

#### GAIUS PETRONIUS

“Mundus vult decipi, ergo decipiatur”

Whatever its true origin, it is a long lived statement... *The world wants to be deceived, so let it.* The image is near and all around us, as a tender deception if we or someone else lets it be. Architecture as image, and architecture being image, is no exception. The icon is here and near, to serve as the tender deception, which you yearn. Hineini, hineini! It says. Especially the “fantastic”. Look at me, look over here. A magic trick, so common, you’ll even fail to notice its magic, is about to appear.

Hineini is an old biblical word that says “I am here”. Though hineini means more than just “I am here.” It is more like a command and has a proclamation to it: “Behold! It is I”. It was Moses’ response to the burning bush, being God, calling his name. Hineini, says the iconic!...when the burning masses call out its name, and it’s urge for a belief to consume.

Architecture, primarily of the non ordinary, and not anonymous kind, carries a character line in the play, that would be uttered if architecture wasn’t a silent scenography. Namely: Hineini! Often this exclamation seems stronger for modern, post-modern, and contemporary architecture.

It is there even when the design is as minimalistic and reduced, as Zumthor’s — with his particularly profound attempt of reverence to material and of showing respect in its place connection, that its annexation of the place almost becomes a mellowly whispered ‘pardon’. Even in this, the seemingly most puritan architecture, which worships the magic of the everyday, the essence rich search for the delicate sensory, and emotionally greater, and poetic rendezvous. Or in the minimalistic reduced for the sake of unity and the purity of essence and concept, on the verge of reducing also human life’s potential to make an eventual imprint. Even in this architectural design, sometime even more so, there is this self-conscious declaration. An almost ideological exclamation. Sometimes so silently loud, that its sub-text cannot but help to be interpreted as pretentious, and sometimes bragging.

And if the design is not as minimalistic or pure, it seems to reside on the razor’s edge of becoming a visual abuse, or attack on something that has been.

The Museum of Military History in Dresden, by Libeskind, being a potential example. Or a degenerate form of something that has not yet been explained... Wicked and incomprehensible, if seen from a more conventional or “common” gaze on architecture.

This architecture is like a child, or an overlooked person, who can't take it anymore, and gives its all to gain attention — ‘look at me, see me now’. Or perhaps it's another kind of exclamation; of boredom, discontent. Or a cry out of something close to exhausted discouragement; a *prompt*, ‘now you should see me, really see me, not just look or gaze’ — Hineini! Hineini!

Or is a covert claim that architecture's resources and ideas are exhausted, as a consequence of a growing desire, visual hunger, and wildly consuming mass? In conjunction with a growing force of architects who needs and wants to express themselves. A call about a stated of Depleted resources of the mind, and now comes the outburst, where anything could suffice. Anything esoteric, or wicked and weird, or mimimalistic enough. Since it may still hold true, may still have any explanation, meaning and message, and be anything until reason has caught up with the outburst of constructs. Anything could be understood, because there is not yet any adequate critique that must be taken into account. False understandings they may be, but not yet able to be falsified, they hold as truths. In the land of no preconception everything may hold true. And that is sometimes worth more than all the promises of reality and reason. In the unknown hope may reside, the sublime, when all other possibilities are depleted. Then we don't want reason, but a vision or dream to keep us beating on. Our image and consumption cult doesn't help. We are fascintaed by the fantastic. And the iconic.

## 6.10

### The Iconoclash

John Berger (2008[1972]) opens his *Ways of Seeing* with:

“Seeing comes before words.”

Words of the world can never substitute or undo the fact that we are surrounded by the world, Berger states. A world that today is infested, embellished and overlaid by the redundancy of imagery. Our world is superpositioned by images, enhanced and cancelled out — as in the physics of waves. And the [image] world has inherit the property of being in multiple positions and states at the same time — as in quantum physic's superpositioning (see **section 6.4**).

JOHN BERGER

“The relation between what we see and what we know is

never settled. Each evening we see the sun set. We know that the earth is turning away from it. Yet the knowledge, the explanation, never quite fits the sight.” (Ibid)

The world today is in images, *sights* recorded from *the* reality re-created in a new reality. Fictional or not it appears more real, less pseudo, by every day and technological break through it seems. We can flee from images as much or little as reality today. If you attempt you will just delve into a new mediated image reality. A detox from the image reality is hardly conceivable within our society, as of now.



Key 8:  
An unintentional iconoclasm? See  
Appendix V.

When an image or artwork meets reality today, the one may intercept the other. Juxtaposition and superposition occurs. It may be of intention or mishaps, by professional or amateur practice. But in a world infused with redundancy, contextual overload, and image consumption, this will potentially render an “icono-clash” (i.e. an ironic iconoclasm) (see **Key 8, Appendix V**). As some of the design output and visuals of this thesis intentionally makes use of.

## 6.11

### Interfaced

Architecture does not appear in an isolated state as an objective an concrete fact. But as a source, sometimes a kind of source code, as well as agent and regulator. Its physical and concrete interface becomes a projection surface or screen. All set within the actor network web. There is a thingly and dynamic nature of architecture, and the icon, to consider. A “nature” which actually belongs to the essence of architecture.

Furthermore architecture is not only about the built, and the world as is, but equally much or more about the world to be. Of our wishes for it, interventions in it, and so on. Architecture then is about the intention of [potentially] being built, or become the next iteration of reality. It is future tense, and as such architecture does well as image, so well it becomes a practice of imagery, and subsequently the imagined and imaginary.

The icon is architecture transformed into a certain kind of image. Architecture has a permeating quality being an image. Much since images has a permeating quality, especially suiting our present day culture, life and communication, making them onmipresent. This is why architecture so easily becomes image. This image is then mediated by an interface, while the image and architecture itself being an interface (see **Key 1-2, Appendix V**). Architecture already from its [intended] essence is a real life, material interface, which assumes a widen scope enabled by being transformed into an image.

Granström (2022) reasons in an essay that the perceived reality is better described as a kind of sign. More particularly she denotes it as an *icon*, which becomes our interface for perceiving the underlying “phenomena” or “thing”. Furthermore, she means that if we let go of the presumably false assumption that our senses make us perceive “reality”, then our perceptions do not tell us anything about what in our surrounding that is conscious. The consciousness is perhaps rather something primary, and all existing concept, everywhere in the universe. Granström means that the perception of the world and the difference between living beings, is not to be decided by the level of consciousness of any entity; be it a stone, an ant, or a human; but by the level or degree of information which the icons of every single entity’s perception mediate of the underlying; that is to say, about the phenomenas and essences of the things the icon “actually” resembles.

6.12

### Image Translation

MARSHALL MCLUHAN

”Art, or the graphic translation of culture, is shaped by the way space is perceived.”  
(2008[1967], P. 57)

The icon is an interface of a translation. From a reality interface, to an imagery interface, connoting a collective world view. The image of an icon, translates reality or idea, and in doing so gives it a commonly shared interface. Architectural icons may be viewed accordingly. As perceptions of space and spatiality, among other aspects, they are part of our culture. And in being so they shape not only it, but our world view as well. Which effectively is our environment for perception, and the “context” of the icon itself.

6.13

### The Prompt

The prompt highlights the *shift* from text to visuality, and future wise potentially other hierarchies of media and perception. Our culture’s media seems to have rendered text increasingly redundant. The text prompt in AI generation, is the “last sigh”, an implementation of an old familiar medium, for testing out a new one. To project diagrammatic:

**(Recent past)** text → image

**(Present)** text ↔ image

**(Near future)** ?[sound/speech] <—> image

**(Future)** ?<—>?

Which will mark the direct, simultaneous, interconnected, participatory, and immersed, that is “pure transaction” of media [medium in plural].

“Prompt” doesn’t only mean *to bring about* or *cause*, but also “swift”, “rapid”, “quick”. Which is the style of the [visual] consumption culture under way, in the lived society of the spectacle.

The thesis makes use of the AI prompt to translate from text and idea, to visuals, to new architecture. Which in essence is three dimensional spatial situations, which are partly turned back into new imagery. But also auditive expressions and scents.

6.14

### Multi Sensory Amplification of the Iconic

If “purely visual means of apprehending the world are (...) just too slow to be relevant or effective.” (McLuhan 2008[1967], p. 63); it nurtures an idea of making the iconic aspects of a design present themselves in other forms than only visual. For instance experiment with and utilise olfactory or auditive properties, qualities, or aspects as well. In this way, a design can also flirt and come closer to “the multidimensional space orientation of the ‘primitive’”, which the electric circuit is recreating according to McLuhan.

MARSHALL MCLUHAN

“Primitive and pre-alphabet people integrate time and space as one and live in an acoustic, horizonless, boundless, olfactory space, rather than in a visual space. Their graphic presentation is like an x-ray.” (Ibid, p. 56f)

Sound and scent are multi sensory aspects that can be both potentially “consumable products” — think of a perfume — and communicators of the icon’s “iconic quality”, thus being part of its “iconicity”. Aspects that possibly can promote a faster pattern recognition! For instance, regarding a potential olfactory manifestation of the icon, note that:

BRUCE MAU

“The sense of smell is only a few synapses away from the brain. Smell is the most direct pathway to memory. That is why we can remember smells four times as accurately than images, and for much longer time”

(Lupton and Lips, 2018, p. 23)

Regarding sound; the consumption of audio books and pods — consumption by means of listening and *not seeing* — are on the rise in Sweden (Stjernkvist, 2025). And we control phones, home assistants and speakers, and create prompts by talking. New media is overtaking old. Ratios of sense perceptions are under renegotiation. An eye is traded back for an ear (the one we traded away according to McLuhan). New ratios to be designed for are here. In the world of printed words and media there have, for instance, been many “efforts to introduce an AUDITORY dimension onto the visual organization of the PAGE” (McLuhan, 1967[1996], p. 117). This has been a way of effecting information, rhythm, inflection, pauses, by means of changes to and in the typefaces, the typography, and layout. An icon needs an auditory effect in its visuals! And perhaps a multi sensory approach in more general terms as well.

We live in and with the *sensory turn* which directs a focus towards the totality — immerse yourself in a direct experience, an orchestrated all at once impact in your one center of attention. The chaos is the non-design, a *noise*. The design is a *signal*. Inspired by Bruce Mau’s idea, presented in “Designing LIVE: A New Medium” (Lupton and Lips, 2018), this totality may more effectively happen within a grander and more direct sensory scope today if we approach the multi sensory realm. According to Mau, the multi sensory design is a feed; not a singular object or image, but a synthesised signal, lived in and experience through time (Ibid). Why would we not argue that the icon is ready for the sensory turn as well? It may be revitalised, strengthened, deepened, more visceral, affective and effective this way. More *immersive*.

McLuhan and Powers (1989) end their book, *The Global Village*, with an index on transformations in the world life and media of the 21st century, in what they call a “A Glossary of Tetrads”. The glossary follows an (A), (B), (C), (D) bullet point structure. Tracing a speculative shift, by posing concepts as entries in the glossary, and explaining the concept’s previous role; working or effect; and its reverse, flip, or change, in the proposed transformation in the “new age”. On the entry “Copernican Revolution”, they note it will; “(D) Flip into relativity — centers everywhere and margins nowhere (acoustic space)” (Ibid, p. 170). This can be used to argue for a visuality beyond a *unilateral sensory one*, generated by only look and gaze. Hence regarding “iconicity” as *not* a unilateral property of the icon. The visual centric idea, infused by the invention and expression of perspective and the vanishing point, from invention or discovery by the renaissance architect Brunelleschi about 1415 onwards, has fostered and nurtured the idea of beholders. And furthermore placed us “outside” looking in or on the world and its representations, converging in a believed in imaginary point or singularity. But with the quoted “flip”; simultaneous and shifting “vanishing points” or “centers” endorsing inclusion, may emerge anywhere, and we within them. Other sensory input, as sound and scent, have this more

naturally inherent in them than sight — as of now at least, with our visual heritage and beliefs still affecting how we “look” at “looking”. Sound and scent don’t possess vanishing points in the conventional sense, but are perceived more as an *immersion*.

In an paper on museum architecture for embodied experience Tzortzi (2018) explores how museum architecture has changed in regards to the sensory turn. In the study architecture is by delimitation understood as arrangement of spaces, with the application of a space-syntax-oriented approach. Tzortzi states that there has been an increase in interest for engaged and embodied experience, along with focus on emotive forms of knowledge. Hence, the study argues for how a certain type of space design and layout “offers a spatial affordance for the juxtaposition of discrete immersive experiences”. The study also argues for how the spaces created uses non-verbal forms of communication, and how inherent sensory qualities in architecture along with imaginative technological implementation can be used to emphasis an *embodied* and *affective narrative*.

Sensory design *opens up*, since it considers not only the shape of things, but the how they themselves shape us. Sensory design can enhance well-being and health, and it is inclusive. The senses are not lonesome entities; because senses triggers and amplify other sense — they are plastic. Not the least do effects of *synesthesia* show us this. The senses “chatter constantly with each other”, they “merge and mingle”. Neither are the senses static nor definitive. No, the senses mix with memory, and imagination; one sense telling the other what to expect. They move us through space. And not to forget, they constitute a somewhat unique, subjective, set up to each person (Lupton and Lips, 2018).

Thus, a multi sensory approach supposedly enhance the imageability as well as a kind of “resilience” and flexibility of the iconic design, even beyond “consumption resiliency”.

Architecture holds multi-sensory qualities inherently — so why not use and delve into them? There are obviously much to be won. Although, “sensory design celebrates the qualities of place” (Lupton and Lipps, 2018, p. 17). While this fact may be an atonement and resolve a deficiency for the placeless design, and nature of some icons. For the nomadic or non-place design and icon, or the one with ambivalence towards place, it might however be a hindrance for complete freedom and universality, or its boundless crave. This is apparently a double-edged sword, especially with consideration of the culture and media of the now, and with regards to the nature of the icon (described in **section 6.2**). If we assume that: architecture = place; then sound and olfactory aspects should indeed be considered part of it — *the signal* — and why not, consequently also the “icon”, increasing its *signal-to-noise ratio*. But on the other hand, we have already noted that the icon is not necessarily place bound or physical in that sense, and situating it in a physical locale would on this opposing note, *not*

*make sense* — in a double meaning... For example, if we assume that iconic architecture  $\neq$  place; a sensory input as smell could as well be regarded as “noise” instead, which could deflate the signal-to-noise ratio of the icon. Unless the scent has been primed well enough with the icon, as to be part of the signal, not the noise.

However, the icon striving to enhance its signal-to-noise ratio; amplify its iconic signal; and wants to suffice the urge of immediate appeal; should *not* only *look* to put on an easily digested wow-factor, or assume a quickly consumed visual iconicity. But engage in an immersed synthesised impact, wherein, for instance, scent possesses certain powers beyond the visual. The visceral icon, in time of the sensory turn, simply put, holds more. A grander promise and experience.

## 6.15

### Modality of Drawing: Proxy, Meta and Autogram

The expression, model, representations, drawing and image of architecture can by convention act by *meta* or by *proxy*. We may see it as modalities of the expression in question. In linguistics modality refers to how our language may express a clause’s relation to reality or truth. This may for instance be done by usage of modal verbs, also known as “helping verbs”, such as: may, would, should, must, could, etcetera. Modality should here be read in a similar way; as expressing how the expression in question of the architecture relates to reality or truth; as well as the way in which it interacts with us. Both its intention and performance, in a sense.

Dal Co argues that what he calls the “contemporary drawing” has become a vehicle for something else, than its mediated architecture (see **section 4.3, 6.8**). Most importantly a vehicle of its own and the new. Dal Co even describes it as if the contemporary drawing carries a fear of becoming real, and by means of its claim for autonomy, it ironically tries to postpone the moment of it becoming what it re-presents, an actual built reality (Decroos, B. et al., 2020). This drawing is *meta*. Referring to itself, or its genre, becoming a self-referential thing.

All architectural drawings, especially of the contemporary kind, and representations are in some sense meta until what they convey, the intention of being built, are realised and built. That is to say, they are not really re-presentations, but presentations. One may say re-presentations of an idea or abstract thought, but as such concrete presentations of the abstracted. Being meta in their self-referential statement. Unless they renounce their state of meta to firmly declare themselves as proxy of an intention. Which may happen if the drawing doesn’t manage to retain a suspension of disbelief, or if it becomes an entity of its own.

When the *intention* no longer is intentional, but in some sense “real” or “reality”, the drawing naturally turns from meta into proxy. The presentation becomes a representation of *real*, acting on behalf of the executed intention. Meanwhile the drawing can turn itself into an image in order to remain autonomous and in some sense detached from the real. If this image, as an image detached from its initial intention, trumps the executed intention, the built instead turns into a re-presentation of the image.

Being meta and autonomous image may be a treacherous state. Not so much for the image or its message, as for the receiver or beholder. By being meta an image may mask its intention, to already become its *itself*. That is to say, not only foreshadow it, but be it. Not on behalf of the other, as in proxy, but in itself. And thus interfere and hustle the reality claims. The meta version, since it is what *it* is, will supposedly be more evocative than the proxy version. Though the proxy may be as evocative if it becomes an entity on its own, a real deal in its own means, with its own claims. Be the referent rather than the reference. For both versions or states of being, it comes down to how they manage to sustain a suspension of disbelief, to retain the receiver within the illusion, narrative, or claim.

A photograph has both an *indexical* and an *iconic* nature, relating to the semiotics of Peirce (Kjørup, 2004). Hence it is dubious. In essence it is an expression in a state of proxy. However, by its iconic nature it does its representation so believable, that it may become a pure presentation and expression in a state of meta. Not only mediating, but *being*.

In one sense, the design outcome in form of various expressions of this thesis, intends to be part proxy, but more so meta. In the sense that the expression wants to be and comment what it itself expresses. If using Peirce triadic model and semiotic notion, of *object* (what is represented), *representamen* (what represents something [else]), and *interpretant*, which is the mental image, idea, concept or meaning conveyed by the sign (Liszka, 1996); this means that the expression of the design outcome here intends to be both object and representamen, at the same time, in its creation and mediation of the interpretant. What is looked for is a kind of tautology. An image of the image of architecture. Or an image of the iconic.

However, this is not a quite sufficient description of the design outcome's and its expressions' intention or modality. One way of putting it would be to say that the design outcome in part, ideally would express itself as a kind of “architecturing photograph”. Not an architectural photograph representing a built intention by proxy. But an architectural expression, intention, or comment, as both an indexical and iconic image. Thus, being potentially in a state of meta *and* proxy, the design may be read as a conceit and tautology of iconic architecture, or an image of architecture as image, if seen from an external or

meta level.

To explain this “ideal” or intended modality of the design outcome’s expression of the thesis further, we supposedly need to introduce a third type of acting or modality of the architectural drawing or image, beside the *meta* and *proxy* state; one we could call the *autogram*. Here referring to a modality where the drawing *is* the architecture; *no* manifestation, *nor* representation. A third modality which would not completely comply with either of the conceptions reflected upon by Somol and Whiting (2002); talking about the idea of the critical project *contra* the projective practice. In the first instance, architecture and its inevitable representations — along with the necessary constant reproduction of the representation and its inherent comment on being a representation — acting as indexes. A kind of representation of indices, being traces of reality. While in the second instance, the projective practice, the diagram present itself as an important tool of the virtual instead (Ibid). However, these both instances, of the index and the diagram, seems to be instances of the modality of meta and proxy, respectively.

A third modality would propose an idea where the drawing or image of architecture is acting neither by means of meta nor proxy. Neither as index nor diagram. But as an *autogram*. It would be itself as image and the architecture, both index and diagram, as well as the object or thing itself — *an iconic modality*. It would present a modality of both reality and the virtual. Or, if we put it differently, as both intention of real or built architecture, and virtual speculation or proposition. (The former being the concept most often showcased in the projects in the master thesis profile of “Building Tectonics” on Chalmers School of Architecture; while the latter most often is showcased in the master thesis profile of “Architectural Experimentation”, for example.)

The word “autogram” is according to its Wikipedia article (accessed 20 Feb 2025) coined by the British electronics engineer and recreational mathematician Lee Sallows (b. 1944). Its concept originally refers to a sentence which describes itself by means of providing an inventory of its containing or constituting characters. As its Wikipedia article states it is obviously a perplexing task to write such a sentence, since the object, or objective, of its description will be unknown until the description itself is complete. Since, again, the description is the object or objective of the description.

Translated to our discussion and theory regarding architecture, drawing, representation and image; the autogram here talked about could be put as follows (if we translate description to image, model or drawing, and object or objective to architecture): The drawing(/model/image) of the architecture will remain unknown, and hardly preconceived nor complete, before the drawing(/model/image) in itself is completed. Since the image is the architecture of an autogram.

The autogram as a third modality beyond the index, as a trace of reality, and the diagram, as a tool for the virtual, holds potential, as an iconic manifestation of sorts. This thesis' design outcome was initially intended to be expressed as an autogram. Has it succeeded? Its up for reflection. Anyway, in such a sense, be both and simultaneously the drawing, the image, and the object or thing itself, all at the same time. In this modality lies a special potentiality. Though, the somewhat complexity of conceiving this modality might fail the actual attempt of the expression, as well as the potential initial difficulty of others understanding the concept, may obscure the desired and clear enough conveyance of the intended modality. Resulting in the expression, all the same, being understood, subconsciously or not, as acting by meta or proxy. Since these are the more conventional and common modalities of the mediated expression of architecture.

**BODY**

7. REALITY, DREAM & DESIGN

## Gothenburg Metro — A Long Lived Dream and Snake

Or a slow dying myth?



Figure 2.1 Extracts from railway investigation maps from 1934 and 1967 (Östergrens Radio, 2009).

Fig 20:  
Excerpts of maps from the  
Gothenburg metro investigations  
of 1934 and 1967.

Carl Axel Reuterswärd (1875-1963) was an engineer educated at Chalmers. He worked as a director's assistant to Sigfrid Edström during the electrification of the Gothenburg tram network in the year 1900. And later, as the tram line director himself, he put forth the so called "Lokalbaneanredningen" in 1934. A proposal for a future metro below the grounds of Gothenburg, today almost forgotten... It was never realised. But in the 1960's the idea of a metro was revived, to connect the planned and soon developed new suburban satellite communities of Gothenburg. The investigation "Stadsbaneanredningen" was presented in 1967 (Rudolphi, 2012). The metro idea was presented as a premetro, called "stadsbana".

A premetro is almost or entirely without plan crossings, just as a pure metro, but the rolling stock is trams or tram like vehicles, and tracks carries a catenary line, or overhead contact line, for the electric power transfer. The premetro most often runs above ground except for the more dense city core.

In the end of the 60s governmental subvention were issued for the Stockholm metro development. The demand on Gothenburg in order to be granted a similar financial support, was that the new lines were to carry equivalent standards as the Stockholm metro. This effected the development of the light rail stages of the lines above ground connecting the satellite communities, in fact executed with almost metro standard. The only subterranean station Hammarkullen, being one stop along the line. However, the central metro was never built, due to lack of insufficient financing, and, or, lack of political willingness (Rudolphi, 2012). Furthermore , the clay which much of central Gothenburg rest upon, makes a metro system difficult to execute. It is at least an often first raised comment — or excuse?

CUT TO:

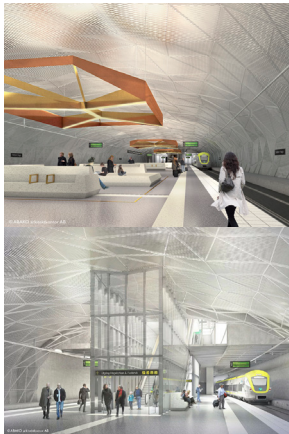

Fig 22-23:  
Renderings of stations for  
“Västlänken”, designed by  
ABAKO Arkitektkontor AB.  
(Courtesy of ABAKO)

2001 and 2002. When an idea study and pre-study was conducted for the project named “Västlänken”. A subterranean railway line making a curve beneath the city of Gothenburg linking three new stations: Göteborg Central (below today's terminus railway station), Haga, and Korsvägen. Connected to the national north bound lines in one end and the southbound line in the other. The vision is to make travel by commuter and regional trains “more convenient, faster, and with fewer change overs” (Trafikverket, n.d.). Financing was approved in 2009, and after investigations, protest and discussions, political decision and granting on national governmental level, and approving in court of appeal, during the 2010s, the project finally was begun construction in 2018. To date the project is delayed but the new Grand Central station is planned to be operated by 2026 and the entire line by 2030 (Ibid).

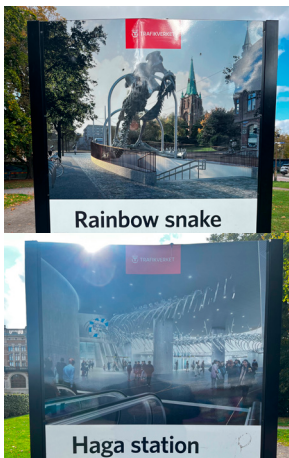

Fig 24-25:  
The artwork Rainbow Snake by  
Huang Yong Ping, supposed to  
embellish the station of Haga in  
“Västlänken”.

However, there has been major political debates and a still exists a opposition against the project among the people of Gothenburg. A lobby group and non-profit association Gårdalänken (n.d.), with the website Tunnlebana.nu, is in opposition of “Västlänken”. *Not* of the idea of a subterranean railway line, but the intended output and use of “Västlänken”. They argue the societal economic gain is lower than it could be. Instead of seeing “Västlänken” used as a by pass for commuter and regional trains, they want it to become the start and first investment, the aorta, of a future and grander central metro network of Gothenburg — the slumbering dream and faded vision of Reuterswärd wakes again.



Fig 26:  
Station locations of the projective  
Lavender Line. Overlay drawing  
of Stadsbananätet (schematic  
map of the metro proposal of  
lobbyist group Tunnlebana.  
nu), catchment area and line  
of Västlänken (Trafikverket),  
and Google Maps of central  
Gothenburg.

The design output of this thesis connects to the vision and line proposal of Gårdalänken. Sharing some similarities with both the 1934 and 1967 proposals. Namely designed spaces of three subterranean stations, complemented with an above ground entrance motif, for this schematically proposed metro network. With basis in the theory of a new reading of the iconic in architecture, image, and translation of image to architecture. The designerly approach induced by the theoretical framework diverge from the ordinary idea of what a subterranean station should, or could, *look like*. For instance the design propositions expressed in renderings by ABAKO Architect Office. Or sculptural and artistic add-ons, as the The Rainbow Snake by Huang Yong Ping, supposed to embellish the entrance and station of Haga. This thesis doesn't appeal to the ordinary infrastructural station design or architecture, but to a spatial *experiential* one, with basis in reading, interpreting and transformation and translation of imagery and the iconic. It doesn't need artistic or artwork add-ons. In one sense it rejects them. The space is a spatial artwork and visceral icon already, by means of experimentation with pure architecture.

## Metro as Infrastructure and Rendered Art Space

The Stockholm metro system is sometimes called the worlds largest, or longest, art exhibitions. Or to put it more poetic: *A subterranean network of art galleries in tube shaped caves.*

SL (Stockholms Lokaltrafik), the principal organisation of Stockholm’s local collective traffic, writes on their website:

“Stockholm’s Metro system is 110 kilometer long and houses a unique collection of sculptures, artworks and exhibitions. There is art at 94 of the 100 stations, created by 250 different artists.” (SL)



Fig 36:  
Details of the glazed tiles in artistic patterns of T-Centralen metro station in Stockholm.

It started to be developed in the post war era in the mid 40’s, and with governmental subventions in the 60’s. Reaching out and connecting to the suburban housing projects know in Sweden as “Miljonprojeketet” of the 60’s and 70’s. The stations of the 70’s were designed as “cave stations”, where the crude rock face is preserved, though with its shapes softened by covering with a layer of sprayed concrete (SL; Rudolphi, 2012).



Fig 32-34:  
Hammarkullen tram station in Gothenburg. A “tram cave”.

Similarities of these stations appearance can be found in the only real subterranean station, though for trams, in Hammarkullen in Gothenburg. A suburban community developed as part of “Miljonprojektet” as well. However, with rather mediocre attempts of artistic embellishments — hardly visible behind or within all sot, dirt, and decay. The raw, coldish and humid atmosphere down here makes it a rather sad and pure cave for trams — it is how it is felt, and the “architecture” simply affirms it.

But what if a metro station didn’t have to be a cave. And what if it wasn’t an art gallery, but an art space by its own means — through its own form giving and architecture. Along with Arvidsson’s (2015) commentary on one of the architectural approaches of contemporary museum halls, in which they have become the attraction and art themselves, rather than accommodating their art input. What if we push this approach to an extreme? — Turning the whole metro space into an art space, presenting itself as a sculptural piece with strong image qualities. In fact rendered from a translation of iconic architecture as image, back into an architectural space. Hence, becoming a “museum of iconic architecture”. The space being the artwork, as a performative installation.

## 7.3

**Station to Station**

Fig 29:  
The Lavender Line. 1:5000  
(600x600 mm).

Behold the three station designs along the *Lavender Line*. (Symbolic of love at first sight, as the lavender rose.) Gothenburg's first real premetro line. Travel station to station; icon to icon; image to image:

Stathmós Parthenon (Classic Antique) – *Stigbergstorget*

Stazione Tempietto (High Renaissance) – *Linnéplatsen*

Seagram Station (Modernism) – *Chalmers*

## 7.4

**Conceived Space as Image Space**

The station spaces are modeled from generic and iconic imagery of three different architectural icons. By making each space respectively into a sculptural piece and installation the space is turned into the image and re-presented icon. Each design respectively, turns the space into the artwork itself, by conceiving it as an image space. It is a translation act from the image of an existing architectural icon into a [new and] visceral icon. Visceral by means of the multisensory approach. Meanwhile, the new image, and potential icon, is also an architectural three dimensional space.

The models, in scale 1:87, are casted from self leveling concrete. They are projective longitudinal section cuts through the imagined spaces of the metro stations. However, as models they are *not* to be reagrds as only working by means of proxy. They are *autograms* (see **section 6.15**) — independent and self-contained entities, acting on their own behalf. They are their own expressions and artwork, as sculptural architectonic pieces. Almost furniture like. Nonetheless, with projective and diagrammatic intentions, dimensions, and qualities, as paper architecture.

## 7.5

**Glitched Homage to Bernini, Borromini and Mies**

The modeled station spaces becomes a reminiscence, and perhaps a glitched homage to Borromini and his rival Bernini, of the Baroque era in the 17th century Europe. The former who is said to be the one turning architecture into sculpture. And the latter turning sculpture into architecture. In the spatial situations here, I have now turned image back into sculptural, and image friendly, “architecture”.

Perhaps to be viewed as the modern day ironic comparison to the two Italian masters. Supposedly this could be an example of an architectonic delirium. The wish of an architecture to express itself architectonic-ally, as response to the contemporary societies response addiction.

Even though the design is the results of glitched image and architecture translation, the supposedly new iconic image and design is an interface equally much as the original image, or even further back the line, the original architecture of reality. Iconic imagery is an interface as much as reality is an interface to the human subject. This becomes an example where “actual” truth is no longer as interesting, as the version of the interface. Being what we can access, as well as viscerally, aesthetically and intellectually judge.

All the translations of architectural icons into new icons, via images, are in part blind to the “real”, “pure”, underlying or inherent architecture, its ideology and qualities, in each work respectively. Sometimes the translation stumbles upon it or manages to pick it up. But what matters here is only the image. And more so the somewhat abstracted image. The process sometimes strikes as almost distasteful — an abuse to the arduous work and high ideas and moral put into each original work. While the translation only sees the overlay hero image, the clichés, the repeated notions and messages, and collages these aspects only, into a new icon that may become an image itself. A mostly superficial reading and interpretation, that is rather quick and a historic. But in this sense also somewhat corresponding to our contemporary culture of consumption and imagery. This is part of the hidden message in plain sight, and the “incisive joke”.

For instance the translation of the Barcelona Pavilion into the *Standing Mies Entrance Tower*, is both a homage to the beauty of the building and architectural icon. But not primarily in the sense of the milestone in architectural history it makes, the expressed and concretely designed ideologies of Modernism and Functionalism. But to the beauty and icon status of it as image, and foremost in this case, its plan. Interpreted not as a plan, but a composition here, interpreted and reproduced *unscrupulously*. Does it make the translation a immoral work of architecture? A steal? — Or is the translation a beautiful and iconic case of image recycling and reproduction. The composition of lines in its functional drawing, a two dimensional tool of mediation, is intentionally misread as a complete and autonomous image, and turned into a new three dimensional composition. The horisontal arrangement of the original, is turned into a vertical and new design arrangement. The two entities now only share the proportions and compositions of certain lines, and a shared base image. Their abstracted and original hero image is the same, though their expressional hero images differs.

The materials of the Barcelona Pavilion; roman travertine (limestone), and three types of marble (green alpine marble, ancient green Greek marble, and

golden onyx from the Atlas Mountains); are also translated. Reinterpreted in the *Standing Mies* as a pavilion and showroom of Nordic stones: *Limestone* from Öland or the plateau mountains of Västergötland replaces the travertine in the floor, here becoming the wall slabs; *red granite* in the foundations; the metamorphic and banded *gneiss* in the upright top slab; *pink Norwegian marble* in the internal vertical walls; and the greenish *marble of Kolmården* in the flooring (see **Fig. A1**, **Appendix III**).

The Standing Mies is a standing ovation to the concepts of Modernism and the ideologies of Post-modernism. It is a designed example of the *iconoclash!* (see also **section 6.10**).

## 7.6

### Acheiropoieta

The models, to be interpreted as autograms (see **section 6.15**), are accompanied by *Artwork Drawings* (see **Appendix III**). In this thesis also named *Acheiropoieta*. After the old Greek word, denoting a kind of devotional icon that is thought to be divine icon imagery. This kind of icon has a special place and relevance within christian iconography. The word's literal meaning being something in style with “not made with human hand”. That is to say not by hands of any mortal being. It could however, according to Kitzinger (1958), refer to a kind of mechanical imprint or impression of the original, that have come into being by some kind of miracle.

The artwork drawings is a play and comment on the image idea, production and reproduction, within architecture, but also our current society in general — being hooked on and shaped by imagery. The Acheiropoieta here turns the architectural drawings, most often line drawings, into artwork in their own rights. But they are themselves produced by a process of iteration and copying. In a final stage traced by means of different tools — pencils, pens, scalpel, bone folder, planned wooden sticks in different dimensions — and carbonic paper, on to a fine art paper made from 60 % hemp and 40 % cotton rag. Hemp paper, which is said to be used in the original Gutenberg Bible for instance.

The artwork drawings thus become imprints, made by computer, hand, and tools, as much as the will and effect of the carbonic sheet and its play with the hemp paper. These drawings are a kind of translations in their own terms. They are imprints of originals — of intermediary imagery which never were to be showcased — but also one-offs and own originals. They turn the architectural tool and communicator, as the drawing intentionally is, into imagery of the projective design. And they become own icons of the design. They are no longer only designerly process things, but final and complete image as well. The one, without need to be further realised. Hence they are also framed, here physically,

when showcased. In reality the architectural image and icon is also framed, but most often in a digital contextual frame or by a “platform”. The drawing is thus partly deprived of its transitive and commutative qualities, when moved into a different picture; or better put, image realm.

7.7

## Scent and Listen to the Autograms

The three revisited, translated and reiterated main icons (see **section 5.7**), has resulted in the design of the three main spatial situation. Which are presented as *autograms* (see **section 6.15**), in the form of one casted station space respectively. As described in **section 5.6-5.7**, the design phase of this thesis has additionally resulted in:

- (1) Three *eau de parfum*. Scents designed as perfumes, which primes the casted models/autograms.
- (2) Three *ambient audio tracks*. To go along with each casted model/autogram respectively.

Thus the iconicity of each design attempts to expand its visuality, by enhancing the experience of it and strengthen its impression. In this way the thesis has taken on a multisensory approach to its designerly work and expressions. As a part in its intention to look for and open up for a discussion on expanded visuality within the realm of architecture and the architectural design practice with its expressions and communication, that is and has been a strongly visual centric practice. Although other fields of art, as well as other design practices, have embraced or opened up for the so called *sensory turn* (see **section 6.14**).

The scents become mediators, in a similar sense as the drawings, models or imagery and other visuals of the suite of work in this thesis. Even though, they in this thesis are designed as artistic scents, to be used exclusively within this project and its display; as *eau de parfums*, they also comments on and connotes an iconic and a consumerist aspect. The latter being closely related to the theoretical framework and discussion on the culture of image and image consumption. Which the architectural icon, its image, and practice of drawing and communication is related to as well.

The perfumes could function as distinct makers, to bring about reminiscence, designed sensations, and particular “images”. Meanwhile they are both tangible products and ephemeral “things”. In such a way they share characteristics with both the icon, and the ionic image. And could as well function as an iconic sign or representamen of the iconic object or referent. Supposedly it all comes down to how well they may resemble or be *like* the iconic, which the icon intends to

be or look like (see **section 6.2**). Or how well it may become the “borderless things of devotion.”

The key to the perfumes, as scents, is that they already is bordreless in some sense. As the models are primed with the scents, anyone or anything could be primed with the scent. Carrying it. Spreading it. An iconic scent could contaminate its iconicity all over. The ultimate connotative shadow (see **section 6.5**)? So why not engage in reinforcing architectural and architecturing scent profiles and scapes.





N.B.

This is *not* a discussion *explaining* the results of the thesis. The effectual and dynamic, as well as the final interpretant of the work, lies within the work itself in interaction with the [mass] audience, as already outlined in the theoretical framework. Nor is it a discussion of the iconic in relation to architecture, which is presented implicitly within mediation of the work, as well as continuously commented upon in this booklet's previous chapters. What follows is a recap and reflection on the thesis questions, as well as a final remark on the nature of the designerly and imagery work, as well as the other expressions in the suite of work seeking to evoke sensation.

8.1

## Design for the Iconic

So can we design *for* the iconic? The answer lies partly in the design work and expressions of this thesis; is the design recognisable?; does it carry a high level of imageability?; does it look like *it*?; or does it have potential to eventually become an image setting up an expectancy, on reality as well as other images, that will make it succeed in fulfilling the condition of likeness? The other part of the answer lies in reality and its embrace of a design.

The answer of the overarching question still has to be: Yes, we can. If we know the workings of images and icons. Though they are set within a web of relations and a partly implicit collective conviction. If something is iconic is in this sense not an A-objectivity, as in true, no matter the condition or agents. But probably carries a characteristic of B-objectivity, as in a partly objective property of the object, but realised in relation to its actors and the joint network.

## 8.2

**Architectural Tautology**

The outcome in terms of imagery expressions and designs of this thesis suite of work, are intended to be experienced as interfaces. They may be read as a conceit of iconic architecture, as in the fanciful and elaborated metaphor. Since it produces an array of pictures and imagery expressions, by its means of translation of iconic architecture and engaging in the image cult and practice of architecture, it could as a sum also be called an “architecturing image”. The outcome is in part *an image of the image of [iconic] architecture*. Thus, it is an architectural tautology.

It is a comment and response, coming from within the image cult of our general culture, as well as of the architectural practice. The different modes of translation, and the resulting design expressions and images, are engaging in architecture that do well as image. That is *the point*, to be made. Iconic architecture, in a culture of image consumption, often seem to be that kind of architecture — the one that do well as image. Or put more scientifically: Have a high degree of imageability of its iconicity. That is to say its iconic content or side, when speaking of it as an expression and, or, as a sign.

## 8.3

**Involution of Iconic Manifest and the Vanishing Point**

In the projective design of the metro stations, part of the iconic manifest (see **section 6.2**) stumbles upon an inversion. Normally, or in the general understanding of the icon, it is a building that can only be seen from the outside, and from a distance. In one sense the icon always lies without or beyond our reach. An icon is in one sense always present but unreachable. We access it by minds and sight. From within the icon itself, it “disappears” for us. Like the treasure at the end of a rainbow. What we are left with is the outlook from the icon, but the icon itself is not *in* this image.

However, in the translated designs for the metro stations this condition is inverted. Except for the entrance situation of *Standing Mies*, the station itself is invisible from a distance. It can in contrast to the normal or generic icon only be experienced and lived from within. The debossed elements of the translated designs even strengthen this idea. Since the translated facades by debossing will be seen from “within”, or by inversion. What we see is a negative if their normal or exterior appearance. Hence we must be within to see them, and being within, we see the outside and image from inside out.

Within these iconic spaces, we are in a mathematic terminology, experiencing the *involution* of the translated icon's *image manifest*.

Just as the artwork drawings, or *Acheiropoieta* imagery, the stations are icons by being *imprints* of translations. Being within, you are looking at the translated icon's envelope. Literally the building envelope, which in most of the cases is what constitutes the foundation of an architectural icon, and the primary expression plane of its image. But in contrast to the common icon as well as the drawings, both being imagery foremost, the iconic station spaces lack the vanishing point of the image or common icon.

An image can have a literal vanishing point, as in the perspective drawings. This is what the station lacks. Since such a vanishing point is only functioning when the motif is watched from a distance. Within the vanishing point, it does what it says — vanishes. The stations are impossible to be viewed from a distance, nor even its proximity, without their image. Or from directly within. The station spaces by involution of the iconic manifest dissolves the hegemonic vanishing point “invented” during the Renaissance. Or at least challenges its norm. Not so much perhaps for image creation, but as consequence for the icon. There is no point left into which everything can converge, since you already is within this very point.

However, in the case of an icon, its vanishing point could also be figurative or metaphorical, in the icon's collective image, as the interpretant of the sign. The point in which common perspectives, understanding, and the collective image of the icon converge. Such a vanishing point potentially still exists within the station spaces' expression and their images. As on potential postcards or other kind of imagery, directing a collective view towards them, when not within them.

In essence, the kind of icon expressed or projected by the design of the station spaces and their conception by translation, is reevaluating the role of the vanishing point for an icon.

8.4

## A Superpositioned Hero Image

As the design outcome has shown, the icon can be understood as an elaborately layered as well as overlaid image, what we may call a *superpositioned image* (see **Key 9-10, Appendix V**). Collective and defined in one sense, yet not static, and also context, relation, and time sensitive. We may also call it a *hero image*, or a *composite image*. Like the ones created by ChatGPT on prompting for an iconic image of “...”; or the collectively created one by top hits on Google image search, or any social media feed. Both this kind of ChatGPT images, as well as top hits

on Google image search of drawings of the chosen icons, has been used in the translation and design process of this thesis' work. What the thesis has explored is how such images can be translated, manipulated, and re-rendered into new architecture, and subsequently new hero images. And in doing so disclosing glitches in this imagery.

The point being that these kind of iconic imagery is part of shaping our *collective image* of a particular building or architectural work — expressed as *one* image, the “iconic” *one*. Looking as the “expected”, of how *it*, the image should look. As well as creating an expectancy for how *it*, the actual architecture or signified, in turn should look.

However, as the design work and produced imagery has shown, this kind of superpositioned and hero imagery, is prone to different sorts of glitching. But if this glitching is concealed or goes by unnoticed, a belief in the partially false accurateness of this kind of imagery is sustained. In conclusion, it is believed, that by working further with exposure of the glitches in various forms, the concept and workings of the superpositioned and hero images, and their forming of our collective image, including both our iconic and common world and view, can be disclosed. Before a hero image could be somewhat confined. As in the postcard. Not anymore. As in the social media post, or the AI prompted render. In a collective image cult, where anyone potentially could, and everyone in fact is contributing, if not always to actual the hero image, so at least to the collective image taste and vogues, the hero image can no longer be confined. But have we lost all control of it? Not necessarily, if we study and know its workings. Image is power, the icon more so. All over again, as in the days of Caesar Augustus. In fact it has never really ceased to be. This is argument for the sake of *why* we should design for the iconic in particular. At least expand our critical knowledge and projective practice to include it as a focus. Thus, it is worth revisiting the iconic concept to develop its new relevance. There is an indisputable potentiality and power in the iconic.

Furthermore, we as architects are in part responsible for the images and image worlds we feed into the image cult of our society. These images have consequences. They form beliefs, and suspend disbeliefs. They not only propose realities to be — they already are realities, upon seeing.

Do we chose to make architecture that does well as image. Or do we resist, and keep engaging in what is inherently good design? Not only good or captivating image. That is to say, there is no inherent conflict per se. But there may be more than image quality, and pleasing visual beauty, or sought after imagery effect.

Furthermore, architecture as effect also has more to give than the visual. Hence the talk of a multisensory approach. The feeling, memorability, experience, a directness, affect and effect, as well as communication and accurate “depiction”

of architecture, may very well lie beyond pure visuals.

#### THE ARCHITECT

Have you seen it already?  
Scented it?  
Heard it?  
What you can't see is already in the air and room  
Have you traveled underground, by the Lavender Line here?  
Have you risen to the top of Standing Mies?  
In your mind it may already have happened  
If you suspend your disbelief  
Architects suspend people's disbelief  
That's how an icon is born  
... Did you get the postcard I sent you  
... All of them  
What did you make of it?  
The Icons reframed

8.5

### Iconic Sustainability

The research question took off in a reflection and discussion of a statement in Rem Koolhaas', by some called polemic manifesto, *Preservation Is Overtaking Us*, from 2014. The original quotation proclaims that: 'The 'star architecture' is dead, and the refuge of the contemporary architect is 'preservation'. It further reads: "Preservation can offer a new path of cultural relevance for architects, but at the price of changing the core of what we believe architectural creativity should be focused on. If preservation is the enabling element of architecture's cultural currency today, then why not expand architecture to include preservation?" (Plevoets and van Cleempoel, 2019, p. 48). The statement place itself within and fit the vogue and contemporary discourse in architecture, calling for an enhanced sustainability focus and responsibility among architects for such questions. Preservation being one such recurring approach and trope in the sustainability discourse.

This thesis has argued, discussed and reflected upon, how our world is hooked on and formed by image creation, consumption and the iconic. Even if 'star architecture' might be rightfully claimed dead, that doesn't necessarily imply the death of the iconic. Correlation is not causation. Rather, in this world — of visuality for credibility, interconnectedness, vast amount of the in-substantial and superficial, multiple reality claims, all-at-once-ness, image consumption, and increasingly "empty branding" — the 'icon' and 'iconic' could be stated being of paramount cultural relevance for the architect and this culture's architecture.

The Koolhaas' statement was thus remodeled by change of keyword, from "preservation" to "iconic". In formulation of thesis question it claimed: If the iconic is an enabling element for the architect's, and architecture's, cultural capital and currency today, then why not expand our critical knowledge and projective practice to include it as a focus.

This was not, however, an oppositional claim of Koolhaas promotional statement about preservation. And not a diversion from a sustainable discourse. No, this is an additional claim and argument. To put it in a potentially provocative way: Sustainability in architecture today, is *not only* about preservation, energy conservation, and other buzz topics, but the image of architecture as well — prominently featuring the iconic. It could also be seen being a question inherent to the essence of design, form, and aesthetics. A core aspect.

Behold the "sustainable" icon. It might not be what you expected it to look like. But it will surely look the most like it — since this is the credo of the icon.

## 8.6

### Sensory Iconic

The fourth research question read:

Can the iconic be expressed in an expanded visibility,  
beyond the pure visual or imagery — and gain from such an  
expression?

The attempt of expanding or re-framing the visibility of the iconic, partly by means of move it away from pure visual understanding, and into another primary medium, is dazzling. If the icon or iconic as a result is comes across as less understood or recognised in this expression, this may be the result of an audience flaw or misreading of its capabilities. That is to say, a push of the expression to far from the ordinary and past the current point of recognition. An overestimation of the capabilities of the audience; not yet being ready to take on or recognise the new ratios of sense perceptions proposed by the expression of this thesis' multi sensory approach. Stating that our current media culture, has not yet shifted the ratios of sense perception into this expressed state, proposed and experimented with by this thesis. Not to say though, that such a shift may happen or already is underway.

However, there may be another potential flaw inherent in the core idea of this thesis' experimentation and attempt of alternative "visuality" and multi sensory expression. McLuhan (2008[1967], p. 81, 86) argued that: "In the name of 'progress', our official culture is striving to force the new media to do the work of the old." And that we furthermore tend to; "impose the form of the old on

the content of the new. The malady lingers on.” If one in the name of progress and acknowledgment of the *sensory turn*, attempts to “replace” a pure visual expression or its “work”, by means of primary auditive or olfactory media expressions — since these supposedly is “newer” and seemingly more fit — this may be a misconception or flawed reasoning. We don’t want “new media” to do the work of “the old”. Neither do we gain from imposing a past “form” on an idea of “new content”, it could be argued. This thesis want to engage in a discourse of the multi sensory in relation to the “icon” and “iconic”. In some sense it has deliberately pushed the envelope, to experiment with and disclose certain aspects. An apt conclusion though, is that a multi sensory approach of the iconic, doesn’t try to replace one expression by just a new or other sensory medium, trying to express the “same”. Rather the idea should be that the other sensory or multi sensory may add dimensions and evolve our perception and experience. Not express the same “iconicity” as the visuals already does and has done; but, as already said, expand an icon’s visuality, or potentially shift it altogether. Either by priming the audience for such an expansion or shift; or, by awaiting such a potential shift in our media culture, and be set for it.

## 8.7

**The Incisive Joke**

In the contemporary world where everything supposedly is to be summarised, clarified and consumable, for the sake of simplicity, satisfaction and convenience, deeper meaning, complex information and essences seems to risk being lost or drowned below the promotion of a superficial approach and explanation. This thesis argues that the iconic is in one sense consumption resilient; not exhaustible in the same sense as much else. Owing much to the icon’s power as image, and strength in letting it be abstracted, extracted, summarised, refined, consumed yet reproducible and further straightened by consumption. It is an image fit for the times. Some of the icon’s value and its value making comes from this quality or property. The question remains though, how far can we abstract something, a design, a concept, a thought, narrative or image, before it is depleted of value, hollowed and means nothing?

The design outcome and result of this thesis’ work comments on this by means of its expression. A master thesis on Chalmers School of Architecture in year 2025, is supposed to be summarised in a booklet as a stand alone and self-explanatory product of maximum 80 pages, featuring a design. Architecture is image and thus expected to be communicated by imagery. But what if the idea of textual summary, design proposal, and image communication, was pushed even further, perhaps beyond a point of rationality and absolute clarity, as understood and asked of now. But reflecting contemporary times and a speculation of intensification of its premises in a potential near future?

This thesis thus, in part, turns its design outcome into a scent. An olfactory product. Both as the final iteration and its mediation. As such it is conceived to be abstracted, yet concretised, beyond the need of explanatory text, and with a new approach to imagery, being scientifically more direct and potentially more immersive than the pure visuals. The thesis' work has thus been outputted as a product of and for the contemporary times. An attempt and speculation of a design outputted as pure essence to be mediated. Ready to be worn and consumed, with your convenience in mind. You no longer have to understand it, just sense it.

Is it for many a still infusible expression of a speculation about a present near future? Perhaps the serious outcome, of turning a collection of unread platitudes in between two covers, into the just as or more effective incisive joke, which McLuhan (1967[1996], p. 10) spoke of? Or is it just ironic "architecture", making a failed and misread attempt of commenting on iconic "architecture"?

What do you sense?

You see  
 I have walked into the great hall  
 And kneeled down by some mighty altar  
 How is that not religious?  
 Am I to blame  
 For how is my image to you  
 Not a conceit of my culture  
 That brought me?

And here I have asked  
 A bigger question  
 And wondered loudly  
 When an echo comes along  
 And you ask too much of me  
 How is that not the price  
 Of asking too big  
 Of asking too loudly  
 In the great hall  
 Of marvel?

People don't want what's real  
 They want what could be real  
 The wish to be real  
 We are fascinated by the fantastic  
 So I thank you  
 If you don't fully understand  
 But still do not leave  
 'Cause you still wish you could know  
 What I made you feel

The age of the stars  
 We live in the age of the stars  
 We are made of their dust  
 I'm something because of the stars  
 I'm less because of the fact  
 Because they are the stars  
 Without them we are nothing  
 Beside them we are small



## APPENDIX I

### REFERENCES

Complete index, used throughout the whole suite of work.

#### Literature

- Arnheim, R. (2004). **Art and visual perception: a psychology of the creative eye**. (New version). Berkeley, Calif.: University of California Press.
- Arvidsson, K. (2015). Arkitektur för eller som konst: Konflikten mellan form och funktion i nutida konstmuseiarkitektur. In **Sciaspoe 7**, Konstmuseiarkitektur / Art museum architecture, 90-182. Göteborg: Göteborgs konstmuseum.
- Asplund, G. (red.) (1931). **Acceptera**. Stockholm: Tiden.
- Austin, M. & Perin, G. (2016). Drawing the Glitch. In Allen, L. & Pearson, L. (Ed.). **Drawing futures: speculations in contemporary drawing for art and architecture**. London: UCL Press, University College London.
- Baldwin, P. J. (2024). Introduction: I Ain't Afraid of No Ghost. **Architectural Design**, 94(4), 7-15.
- Bataille, G. (1991[1949]). **The accursed share: an essay on general economy**. Vol. 1 Consumption. New York: Zone books.
- Barthes, R. (1986). **Det ljusa rummet: tankar om fotografiet**. Stockholm: Alfabeta.
- Baxandall, M. (1988). **Painting and experience in fifteenth century Italy: a primer in the social history of pictorial style**. (2. ed.) Oxford: Oxford Univ. Press.
- Beanland, C. (2021). **Unbuilt: radical visions of a future that never arrived**. London: Batsford.
- Berger, J. (2008[1972]). **Ways of seeing**. London: Penguin.
- Bergström, B. (2020). **Bildens kraft, makt och ansvar**. (1. ed.) Stockholm: Carlssons.
- Buchloh, Benjamin H. D. (1 Dec 2001). Andy Warhol's One-Dimensional Art: 1956–1966. In A. Michelson (Ed.), **Andy Warhol**. The MIT Press.
- Burrows, R., Graham, S. & Wilson, A. (2021). Bunkering down? The geography of elite residential basement development in London. **Urban Geography**, 43(9), 1372–1393. <https://doi.org/10.1080/02723638.2021.1934628>
- Brøns, C. (2025). The scent of ancient Greco-Roman sculpture. **Oxford Journal of Archaeology**, (44), 182–201. <https://doi.org/10.1111/ojoa.12321>
- Cresswell, T. (2015). **Place: an introduction**. (2. ed.) Chichester: John Wiley & Sons.
- De Botton, A. (2021). **Låt Proust förändra ditt liv**. (1. ed.) Stockholm: Volante.
- Debord, G. (2021[1967]). **The society of the spectacle**. (Translation: F. Perlman & K. Knabb). Critical Editions.
- Decroos, B., Patteeuw, V., Çiçek, A. & Engels, J. (2020). The Drawing as a Practice. **Practices of Drawing, OASE**, (105), 13–24. <https://oasejournal.nl/en/Issues/105/TheDrawingAsAPractice> [access 2024-11-01]
- Dunne, A. & Raby, F. (2024[2013]). **Speculative everything: design, fiction, and social dreaming**. (First MIT Press paperback ed.) Cambridge, Massachusetts: The MIT Press.
- Earle, W. (2013). Cultural Education: Redefining the Role of Museums in the 21st Century. **Sociology Compass**, 7(7), 533-546.
- Evans, R. (1997). **Translations from drawing to building and other essays**. London: Architectural Association.
- Evans, R. (2000). **The projective cast: architecture and its three geometries**. (New ed.) Cambridge, Massachusetts: MIT Press.
- Fazio, M. W., Moffett, M. & Wodehouse, L. (2013). **A world history of architecture**. (3. ed.) London, UK: Laurence King.

- Grundell, V. (2016). *Flow and friction: on the tactical potential of interfacing with glitch art*. Stockholm: Art and Theory Publishing.
- Haddad, E. (2009). Charles Jencks and the historiography of Post-Modernism. *The Journal of Architecture*, 14(4), 493–510. <https://doi.org/10.1080/13602360902867434>
- Harvey, D. (2009). *Den globala kapitalismens rum: på väg mot en teori om ojämn geografisk utveckling*. (Translation: M. Åsard) Hågersten: Tankekraft.
- Honour, H. & Fleming, J. (2009). *A world history of art*. (Rev. 7. ed.) London: Laurence King.
- Jencks, C. (2011). What is Radical Post-Modernism? / Post-Modernism: An Incomplete Project. *Architectural Design*, 81(5), 14–23. <https://doi.org/10.1002/ad.1291>
- Jong, I. D., Nünlist, R. & Bowie, A. M. (Ed.) (2004). *Narrators, narratees, and narratives in ancient Greek literature*. Boston: Brill.
- Kemp, W. (1998). *The work of art and its beholder: The methodology of the aesthetics of reception*. In M. A. Cheetham (Ed.), *The subjects of art history: historical objects in contemporary perspectives*, 180–196. Cambridge: Cambridge University Press.
- Kitzinger, E. (1954). The Cult of Images in the Age before Iconoclasm. *Dumbarton Oaks Papers*, (8), 83–150. <https://doi.org/10.2307/1291064>
- Kjørup, S. (2004). *Semiotik*. Lund: Studentlitteratur.
- Krauss, R. (1979). *Sculpture in the Expanded Field*. *October*, 8, 30–44.
- Koolhaas, R. (1994[1978]). *Delirious New York: a retroactive manifesto for Manhattan*. (New ed.) New York: Monacelli Press.
- Latour, B. & Yaneva, A. (2008). Give Me a Gun and I Will Make All Buildings Move: An ANT's View of Architecture. *Ardeh*, 2017(1), 103–111. 10.17454/ARDETH01.08.
- Leerberg, M. (2009). *Design in the expanded filed: rethinking contemporary design*. [Research paper]. Nordes: Nordic Design Research – Engaging Artifacts, 2009(3). The Oslo School of Architecture and Design, Norway, 2009-08-30 – 2009-09-01.
- Lindkvist, L. (2018). *Avtryck: kulturentreprenörer, konsthallar och mecenater*. (1. ed.) Stockholm: Volante.
- Liszka, J. J. (1996). *A General Introduction to the Semiotic of Charles Sanders Peirce*. Bloomington, Indiana: Indiana University Press.
- Lupton, E. & Lipps, A. (2018). *The Senses: Design Beyond Vision*. Published in conjunction with the exhibition “The Senses: Design Beyond Vision” at Cooper-Hewitt, Smithsonian Design Museum, April 13-October 22, 2018. New York: Cooper Hewitt, Smithsonian Design Museum.
- Lynch, K. (1960). *The image of the city*. Cambridge, Massachusetts: MIT Press.
- Mankell, B. (2013). *Bild och materialitet: om föreställningar, synsätt, material och uttryck i måleri, teckning och fotografi*. (1. ed.) Lund: Studentlitteratur.
- McLuhan, M., Fiore, Q. & Agel, J. (2008[1967]). *The medium is the message*. London: Penguin.
- McLuhan, M. & Powers, B. R. (1989). *The global village: transformations in world life and media in the 21st century*. New York: Oxford University Press.
- Mitchell, L. S. (1921). *Here and now story book: two- to seven-year-olds*. New York: Dutton.
- Meynell, H. A. (1986). *The nature of aesthetic value*. London: Macmillan.
- Norman, D. A. (2004). *Emotional design: why we love (or hate) everyday things*. New York: Basic Books.
- O’Doherty, B. (1999). *Inside the white cube: the ideology of the gallery space*. (Expanded edition). Berkeley, Calif.: Univ. of California Press.
- Orwell, G. (1949). *1984*. New York: Signet Classic.
- Orwell, G. & Packer, G. (2008). *All art is propaganda: Critical essays*. (1 ed.) Orlando: Harcourt.
- Peirce, C. S. (1991). *Peirce on signs: writings on semiotic*. (Ed. by J. Hoopes) Chapel Hill: University of North Carolina Press.
- Platon, (2003). *Skrifter Bok 3 Staten*. Stockholm: Atlantis.
- Plevoets, B. & Cleempoel, K. V. (2019). *Adaptive reuse of the built heritage: concepts and cases of an emerging discipline*. New York: Routledge.

- Rudolphi, M. (2012). **Allélänken: A study of the possibility and the potential effects of a tramway tunnel construction in Gothenburg city**. [Master Thesis, 2012:11, Chalmers University of Technology]. <https://publications.lib.chalmers.se/records/fulltext/161322.pdf> [access 2025-04-20]
- Somol, R. & Whiting, S. (2002). Notes around the Doppler Effect and Other Moods of Modernism, **Perspecta**, (33).
- Sontag, S. (2008[1978]). **On photography**. London: Penguin.
- Sontag, S. (1966). Notes on camp. In **Against interpretation, and other essays**. New York: Dell.
- Tehrani, N. (2013). The icon and its shortcomings: In defence of discourse. Under the Influence (Symposium) (2013). In A. Miljački (Ed.) with I. Hwang, **Under the influence**. Cambridge, Massachusetts: SA+P Press.
- Thornton, S. (2009[2008]). **Seven days in the art world**. London: Granta.
- Tralau, J. (2024). **Myten om tidens början**. Malmö: Ellerströms.
- Tufte, E. R. (1983). **The visual display of quantitative information**. Cheshire, Conn.: Graphics Press.
- Tzortzi, K. (2017). Museum architectures for embodied experience. **Museum Management and Curatorship**, 32(5), 491-508. DOI: 10.1080/09647775.2017.1367258
- Unwin, S. (2014). **Analysing architecture**. (4. ed.) London: Routledge.
- Venturi, R., Scott Brown, D. & Izenour, S. (1977). **Learning from Las Vegas: The forgotten symbolism of architectural form**. (Rev. ed.) Cambridge, Massachusetts: MIT Press.
- Venturi, R. & Scott Brown, D. (2004). **Architecture as signs and systems: for a mannerist time**. Cambridge, Mass.: Belknap Press of Harvard University Press.
- Vignelli, M. (2019). **The Vignelli Canon**. Zürich: Lars Müller Publishers.
- Weir, S. (2022). Salvador Dalí in Rem Koolhaas' Delirious New York. **The Journal of Architecture**, 27(2-3), 398-419. <https://doi.org/10.1080/13602365.2022.2106580>
- Wooldridge, D. (2021). **To be determined: photography and the future**. (1 ed.) London: SPBH Editions.
- Wölfflin, H. (1957). **Konsthistoriska grundbegrepp: stilutvecklingsproblem i nyare tidens konst**. (Translation: B. G. Söderberg, of original 11 ed.) Stockholm: Svenska bokförlaget / Norstedts.
- Zheng, J. (2016). **I Am Present**. OJ (om jag bara kunde få det tryckt)-priset, programmen för Arkitektur samt Arkitektur och Teknik vid Chalmers Tekniska Högskola. Göteborg: Chalmers University of Technology.
- Zanker, P. (1988). **The power of images in the age of Augustus**. Ann Arbor: University of Michigan Press.
- Zumthor, P. (2005). **Thinking architecture**. (3. exp. ed.) Basel: Birkhäuser.

## Sources

- Borawski, Z. et al. (17 Aug 2018). How to: not make an architecture magazine. A manual. **Canadian Centre for Architecture**. <https://www.cca.qc.ca/en/events/62023/how-to-not-make-an-architecture-magazine> [access 2024-11-19]
- Carson, D. Archive: The end of print. **David Carson Design**. <https://www.davidcarsondesign.com/t/tag/the-end-of-print/> [access 2014-11-01]
- Castello di Rivoli. (n.d. / web content © 2024). Lucio Fontana. **Castello di Rivoli**, museum, Torino. <https://www.castellodirivoli.org/en/artista/lucio-fontana/> [access 2024-10-06]
- Curkin, C. & Mulvey, K. (7 Dec 2023). The 25 most famous buildings in the world to visit before you die: It's time for an architecture pilgrimage. **Elle Decor**. <https://www.elledcor.com/life-culture/travel/g31101520/ionic-buildings/> [access 2024-10-04]
- Dalí, S. (1930). **La Femme visible**. Paris: Editions Surrealist.
- Demey, M. (18 Nov 2023). C2PA and the Battle Against AI-Generated Deception. **Apryse**. <https://apryse.com/blog/ai-content-cp2a-authenticity> [access 2024-10-31]
- Farhat, R. & Olsson, G. H. (2024). **Spektaklet: Livet som ett enda flöde** [The Society of the Spectacle] [Dokumentär, TV]. K Special. SVT Play. <https://www.svtplay.se/video/KzVBVYN/spektaklet> [published 2024-10-13]
- Fioretos, A. (2019). **Atlas: fallstudier**. Stockholm: Norstedts.

- Gayle, D. (10 mar 2022). Millions suffering in deadly pollution 'sacrifice zones', warns UN expert. **The Guardian**. <https://www.theguardian.com/environment/2022/mar/10/millions-suffering-in-deadly-pollution-sacrifice-zones-warns-un-expert> [access 2025-03-07]
- Granström, H. (9 May 2022). Mycket tyder på att vi inte vet någonting om verkligheten [podcast]. In OBS: Radioessän. **Sveriges Radio**.
- Gårdalänken. (n.d.). **Tunnelbana.nu**. <https://tunnelbana.nu/forslaget/> [access 2025-04-20]
- Huldschiner, H. (29 Sep 2023). Vem vinner modematchen. Di Weekend #38 [bilaga], **Dagens Industri**.
- Mattsson, P. (1 Dec 2021). Ängar som botar den utbredda växtblindheten. **Sveriges Natur**, 2021(5). <https://www.sverigesnatur.org/aktuellt/angar-som-botar-den-utbredda-vaxtblindheten/> [access 2024-11-01]
- Maya, W. (10 Mar 2018). Architecture and image making: it's cultural, aesthetic and media impact as a (not so new) discussion in architecture. **Medium**. <https://medium.com/william-maya/architecture-and-image-making-its-cultural-aesthetic-and-media-impact-as-a-not-so-new-b6672e70d03> [access 2025-01-24]
- Miller, R. (10 Aug 2010). NYSE Opens Mahwah Data Center. **Data Center Knowledge**. <https://www.datacenterknowledge.com/colocation/nyse-opens-mahwah-data-center> [access 2024-10-28]
- Mills, N. (3 Sep 2017). We've Been Saying Goodnight to That Moon for 70 Years. **The Daily Beast**. <https://www.thedailybeast.com/weve-been-saying-goodnight-to-that-moon-for-70-years/> [access 2024-11-01]
- Moderna Museet (n.d.). **Remembering She — A Cathedral**. <https://www.modernamuseet.se/stockholm/en/exhibitions/remembering-she-a-cathedral/> [access 2024-11-03]
- Nguyen, K. (Director and scriptwriter). (2018). **The Hummingbird Project** [film]. Elevation Pictures (Canada); Belga Films (Belgium).
- Powel, S. B. (Sep 2011). High Frequency Trading. (Commentary, Issue 70). **The Hedge Fund Journal**. <https://thehedgefundjournal.com/high-frequency-trading/> [access 2024-10-28]
- Rand, A. (2004[1957]). **Och världen skälvde** [Atlas Shrugged]. (Translation: M. Freccero) Stockholm: Timbro.
- Reimers, C-V. (15 Nov 2024). Dumheten hotar vårt välstånd [editorial]. **Dagens Industri**.
- Schwöbel-Patel, C. (19 Jan 2025). The Coming Battle for Greenland. **Jacobin**. <https://jacobin.com/2025/01/greenland-trump-climate-imperialism-mining> [accesses 2025-03-07]
- Schneider, D. (n.d.). The Microsecond Market. **McKay Brothers**. <https://www.mckay-brothers.com/the-microsecond-market/> [access 2024-10-28]
- SL. (n.d.). Discover the world's longest art exhibition: the Stockholm Metro! **Stockholms Lokaltrafik**. <https://sl.se/en/help-and-contact/the-worlds-longest-art-exhibition> [access 2024-04-20]
- Smith, A. (7 Jun 2014). Fast money: the battle against the high frequency traders. **The Guardian**. <https://www.theguardian.com/business/2014/jun/07/inside-murky-world-high-frequency-trading> [access 2024-10-28]
- Sornette D. & von der Becke, S. (2011). **Crashes and High Frequency Trading: An evaluation of risks posed by high-speed algorithmic trading** (The Future of Computer Trading in Financial Markets – Foresight Driver Review – DR 7). Government Office for Science, commissioned as part of the UK Government's Foresight Project. <https://assets.publishing.service.gov.uk/media/5a7c284240f0b61a825d6d18/11-1226-dr7-crashes-and-high-frequency-trading.pdf> [access 2024-10-28]
- Spector, N. (n.d.). James Turrell, Afrum I (White). **Guggenheim New York**. <https://www.guggenheim.org/artwork/4084> [access 2025-02-20]
- Spurlock, M. (Director). (2011). **POM Wonderful Presents: The Greatest Movie Ever Sold** [film]. Sony Pictures Classics; Stage 6 Films.
- Steiner, C. (16 Jul 2012[2010]). Wall Street's Speed War. **Forbes**. <https://www.forbes.com/forbes/2010/0927/outfront-netscape-jim-barksdale-daniel-spivey-wall-street-speed-war.html> [access 2024-10-28]
- Stjernkvist, S. (10 Feb 2025). Podd-lyssningen fortsätter att öka. **TV4 Nyheterna**. <https://www.tv4.se/artikel/tt-250210-poddlyssning-634f1362/podd-lyssningen-fortsatter-att-oka> [access 2025-02-22]
- Svensson, A. (2020). Veckans nyord: växtblindhet. Språkbloggen. **Språktidningen**. <https://spraktidningen.se/sprakbloggen/veckans-nyord-vaxtblindhet/> [access 2024-11-01]
- Sveriges Television. (2023). Vetenskapens Värld: Nätdejtingboomen [Dokumentär, TV]. **SVT Play**. <https://www.svtplay.se/video/jmLgggd/vetenskapens-varld-natdejtingboomen> [published 2023-03-05]
- Trafikverket. (n.d.). **Västlänken**. <https://www.trafikverket.se/vara-projekt/projekt-i-vastra-gotalands-lan/vastlanken/> [access 2025-04-20]
- Trafikverket. (2020). Järnvägsnätsbeskrivning 2020. Edition 2020-09-17.

## Figures

N.B.

All figures, pictures and images that are *not* referenced is the original work of the author, if nothing else is annotated.

Figure: 2 and 3

*Perspective section*, and *Plan and elevation*, Parthenon, 447-432 BCE., Iktinos and Kallikrates, Athens, Greece.

In: Lu, Fangqing. (2016). Architecture as spatial–textile storytelling: Metamorphosis of frieze as a narrative medium mediating the Panathenaia festival. *Frontiers of Architectural Research*, (5), 489-498. 10.1016/j.foar.2016.08.003.

Figure: 9

Plan, Tempietto del Bramante [Tempietto di San Pietro in Montorio], 1502, Donato Bramante, Rome, Italy. Drawing by Andrea Palladio (1508-1580).

In: Palladio, A. (1965[1738]). *The four books of architecture*. New York: Dover.

Figure: 13

Detail I, Seagram Building, 1958, Ludwig Mies van der Rohe, New York City, USA.

In: Čakarić, I. (2017). *Facade Installation Optimization*. 10.13140/RG.2.2.34868.96642

Figure: 14

Detail II, Seagram Building, 1958, Ludwig Mies van der Rohe, New York City, USA.

In: Kostić, M. (2020). *Functional Excess: Ornamentation in the Post-Fordist Production and Projection of Architecture*. [PhD Thesis, University of Belgrade – Faculty of Architecture]..

Figure: 17

Plan, Barcelona Pavillion, 1929, Ludwig Mies van der Rohe, Barcelona, Spain.

From: Kelly, M. J., (30 Sep 2013). Mies van der Rohe Pavillion. **Jason M. Kelly**. <https://jasonmkelly.com/jason-m-kelly/2013/09/30/mies-van-der-rohe-barcelona-pavilion> [access 2025-04-04]

Figure: 20

Excerpts of maps from the Gothenburg metro investigations of 1934 and 1967.

In: Rudolphi, M. (2012). Allélinken: A study of the possibility and the potential effects of a tramway tunnel construction in Gothenburg city. [Master Thesis, 2012:11, Chalmers University of Technology]. <https://publications.lib.chalmers.se/records/fulltext/161322.pdf> [access 2025-04-20]

Figure: 21-23

Renders of station spaces and architecture in connection with Västlänken, by ABAKO Arkitektkontor AB. (Courtesy of author.)

Figure: 27

Stadsbanenätet, schematic map of proposed metro line network in central Gothenburg by Gårdalänken. (Courtesy of author.)

In: Gårdalänken. (n.d.). **Tunnelbana.nu**. <https://tunnelbana.nu/forslaget/> [access 20205-04-20]

Figure: 40

Static reference profile A and Dynamic reference profile SEa for Swedish railroads.

In: Trafikverket. (2020). *Järnvägsnätsbeskrivning 2020*. Edition 2020-09-17: p. 19.



## APPENDIX II

### EKPHRASISES

#### Translation from Visual to Visceral Icon

The ekphrasises used in translation from image based architecture to olfactory and audio expressions. One for each main spatial situation designed, which are presented as *autograms* (see **section 6.15, 7.7**).

(1) Three *eau de parfum*. Scents designed as perfumes, which primes the casted models/autograms.

(2) Three *ambinet audio tracks*. To go along with and enhance the experience of each casted model/autogram respectively.

Original ekphrasises were written in Swedish. On the staged and presented postcards condensed excerpts in English were published. For the front side image of each postcard see **Appendix IV: Fig. 1, Fig. 7, Fig. 12**.

Ekphrasis I: Parthenon (447-432 BCE)

## **The Icon of Classic Antiquity**

På toppen av berget står ett tempel.  
En del av berget har huggits ut och bort,  
För att kvar lämna proportioneringens och ordningens urmoder.  
Som inte bara ser ut som ett tempel,  
Men är templens tempel och en av den västerländska världens orubbliga relik.  
Det går bortom en byggnad eller arkitektur.  
Det är lika mycket en symbol för demokrati,  
Civilisation, kultur och konst.  
Del av berget, del av civilisationen.  
Som ett möte och ett tyglände,  
Av natur och osynlig matematik,  
Materialiserad i sten och rum.  
Det är här natur blir civilisation.  
Som en elegant stramhet uttryckt i geometri.  
När triangeln blir en tympanon.  
Rektangeln blir en arkitrav,  
Med metop och triglyf.  
Koordinerade geometriska smycken bredvid skulptural relief i en entablatur.  
De fluterade stående cylindrarna,  
Med sina linjärt reducerande omfång,  
Som förstärker vertikal balans och harmoni,  
Markerar med tydlighet och stolthet det bärande.  
Samtidigt som de ramar in rätblockets inneslutna innerst heliga rum.  
Allt poserat på en lätt upphöjd plattform,  
Embryot till en scen,  
Som anspråkslös markör för byggnadens potens och position.  
Den penteliska vita marmor, är nu beigetonad och med skavsår från tidens gång,  
Men ännu lika starkt ett sökljus mot det klassiska idealet.  
Från en tid då det inte var en dröm, historia, eller teori,  
Men en verklig och fysiskt samtida sanning.  
En vithet och renhet,  
Som historien och performativa blickar gjort till mystikens ideal.  
Färgen har inte flagnat, den har försvunnit,  
Och av generationer raderats.  
En air av storhet genomsyrar kropp och blick.  
Ett mått av tektonik möter den subtraktiva stereotomins höjd av bemästrad  
finess.  
Ett mått av luft möter byggnaden som är de tunga och grundläggande  
elementens moder.  
Eller är även jag bedragen av den vita myten?  
I skuggan av ett åldrande olivträd,  
Som ändå inte kommer överleva arkitekturen.

English excerpt I  
Parthenon Postcard (Fig 1, Appendix IV)

On the mountain top stands a look alike temple  
Mountain cut out and away till stepped stage  
Left the mother of order and proportion  
It goes beyond building and architecture  
Art and culture, relic and script, of our west world  
A marked site, part rock, part civilisation  
Where nature reveals invisible mathematics  
Elegance is an attitude expressed in geometry  
Austere it urged when triangle became tympanon  
Rectangle architrave an holy shrine  
Carried and guarded by fluted rows of columns  
White Pentelic marble now torn beige  
From the graze of time and the white myth  
Performative gazes made you the ideal  
Your colour has not faded, it was erased  
Still a sense of pride permeates body and sight  
Or am I too, one of the beguiled?

Ekphrasis II: Tempietto del Bramante (1502)

## **The Icon of High Renaissance**

Petite, petite, petite  
Du är lika mystisk som bekant  
Lika ärlig som osagd  
Lika enhetligt sann som fylld av paradox  
Du är här, men bara nära.  
Du är nätt och ser även ut att vara lätt,  
Trots din släta sten och sakrala tyngd.  
I plan är du koncentrisk disk som staplats,  
Och en cirkel av prickar runt en veckad skugga lika rund.  
Med vit sten som upplöses som material till att plötsligt bara bli form,  
Som redan gör blicken vän innan min hand känt dig.  
Står du där och säger kom sätt dig på min avsats.  
Cylinder, runt, runt, kupol.  
Till mindre cylinder på ärgat tak och tillsist mot himlen en sfär.  
Inskriven i rektangelns gård,  
Står du i din egen fullständiga och slutna värld.  
Pånyttfödelsens fulländning av antikens vision.  
I en liten enhet ryms dess allt.  
Du står här rätt och avslutad på din runda sockel,  
Fem långa låga steg upp.  
Men pågår runt dig själv i oändlighet i din egen cirkel.  
Utan vassa hörn och med rundade kanter,  
Är du mjuk och vänlig.  
Står du här och säger hej.  
Som att du blandar allvaret med lek.  
I en mänskligt nära skala.  
In i ett inre rum av nischer och prång.  
I mitten i golvet ett runt hål,  
Bland livligt ordnade mönster i färger från slipad sten,  
Sipprar en omfamnade dunkel skugga upp,  
Och blandas med dämpat infallet ljus från spröjsat glas,  
Under stjärnbestrött valv.  
Komplexitet som adderar och förför,  
Men också delvis dold av helhetens förföriska enkelhet.  
Elementen sammanflätas till helhet och egen entitet.  
Kolonn och pilaster, nischer och fris, runt cylinderns rymd.  
Endast den svarvade formen hos balustrar i krans,  
Antyder om en kommande tids svulst och större form,  
Och särskiljer sig lika mycket som de passar in.  
Antikens ideal är repatrierat,  
Men möter din plastiska utveckling,  
Som skvallrar om mer.

English excerpt II  
Tempietto Postcard (Fig 7, Appendix IV)

As mystique as familiar  
An honest as undisclosed desire  
Uniformly true as filled with paradox  
Petite, petite, you're so neat  
Smooth stone and sacral weight at odds  
Circle of dots around a shadow crimped  
Dissolves your white stone till pure form  
Elements entangled till own entity  
Cylinder, round, round, till verdigris dome  
Inscribed in the court of the square  
You endlessly linger on around yourself  
Without sharp corners you whisper hineini  
As if you play the serious game  
The middle of the floor holds a hole  
An embracing shadow oozes from obscurity  
The repatriated antique ideal  
Meets your plastic gossip of coming times

Ekphrasis III: Seagram Building (1958)

## **The Icon of Modernism**

Ett resligt svart rätblock sträcker upp sig bland snarlika, men inte helt samma.  
En pionjär, en del som står för det hela, redo för att erövra världen,  
Men med en återhållsam nästan anonym uttrycksfullhet.  
Det är massivt men ändå inte slutet.  
Det är sammanhållet och rent,  
Till vad vissa skulle säga avskalat.  
Det är uttrycket av enhetlig mångfald som möter totalitet.  
Det är en till synes tung kropp av stål och glas,  
Som landar på höga pelare,  
Som ändå framstår som korta men proportionerligt rätt,  
Dock smala ben.  
Eller är det ett par fötter på tå med utsträckta anklar,  
Som sticker ut under den sobert släta klänningens fall,  
Som aldrig möter markens asfalt och betong?  
Pelarna och fönstren är underordnade sitt ordande system.  
Om dagen glittrar och reflekterar sig himlen och stadens kontext i fönsterytorna,  
Som vertikalt markerade rektangulära speglar lätt indragna i det mörka stålets  
rutnät.  
Om natten är det endast de oregelbundet upplysta rummen som tänder fasaden,  
I ett lika dynamiskt som förutsägbart mönster.  
Stål och glas mot stadskontur och himmelshorisont.  
En fullbordan av tre decenniers vision och dröm om en annan skyskrapa,  
I modernismens vertikala fullbordan?  
För i fönstren speglar sig inte längre bara mötet mellan himmel och stad i mina  
ögon,  
Men ett ideal,  
Bortom bara ytan och fasad som bilden och vår tid mest ser.  
Men är den lite tråkig kanske?  
Ett rätblock som nästan kunde pågå närmre molnen,  
Men slutar arbiträrt just där.  
Ändå har någon valt just dessa proportioner,  
Och den slåss inte om att vara högst eller mest, men ändå bäst.  
Den är ett ideal.  
Det är i den nära detaljen, dess proportion och repetition,  
Som i tanken bakom designens val,  
Värdet väntar tillsammans med idén om det vackra och funktionella.  
Det samtida och tidlösa.

English excerpt III  
Seagram Building Postcard (Fig 12, Appendix IV)

A towering cuboid stretches for infinite skies  
Among similars not yet sames  
A pioneer showing how a part sands for the whole  
Massive yet not closed, ready to conquer  
With restrained, almost anonymous expressiveness  
It is the expression of unified multiplicity  
Taking on the task of totality  
A pair of tiptoeing pillars with stretched ankles  
Sticks out under the hem of a sleek sober dress  
That never touches the grit of the paved ground  
Recessed rectangles in a dark grid  
At night live out their lit disarrayed dream  
Bronze and glass on a skyline  
A completion of three decade's vision  
In the vertical fulfillment of the modernism?  
'Cause mirrored in the windows the longing lips  
Of heavens and city touch in a reiterated ideal



### Final Expressions and Visuals

Here follows photographic reproductions, or scans, of a selection of the final *Artwork Drawings*. In this thesis also named *Acheiropoieta*. After the old Greek word, denoting a kind of devotional icon that is thought to be divine icon imagery. (See also **section 7.6**)



Fig A1

### Standing Mies Postcard Render

Acheiropoieta expression in form of rendering of the *Standing Mies*. Cover and hero image, published and performed as postcard. (See also **section 6.5**.)

21x29,7 cm

Note the reinterpreted materials of the Barcelona Pavillion. Here: Swedish *limestone*, *red granite*, *gneiss*, *pink Norwegian marble*, and greenish *marble of Kolmården* (see **section 7.5**).

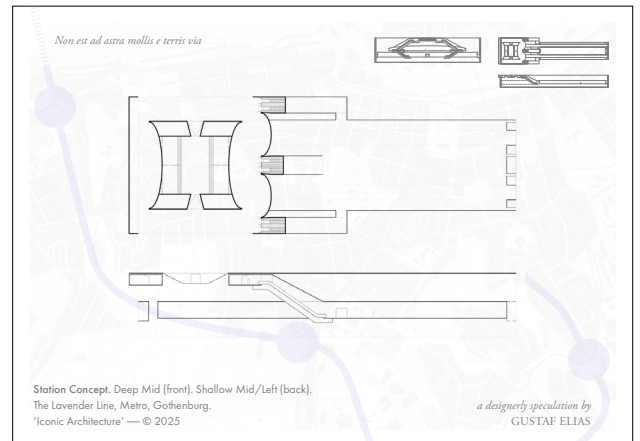
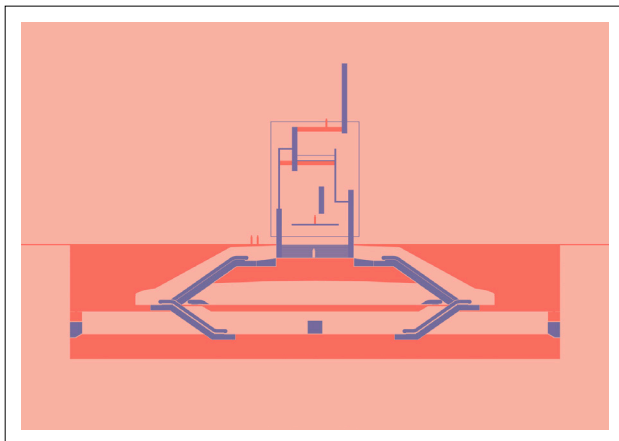
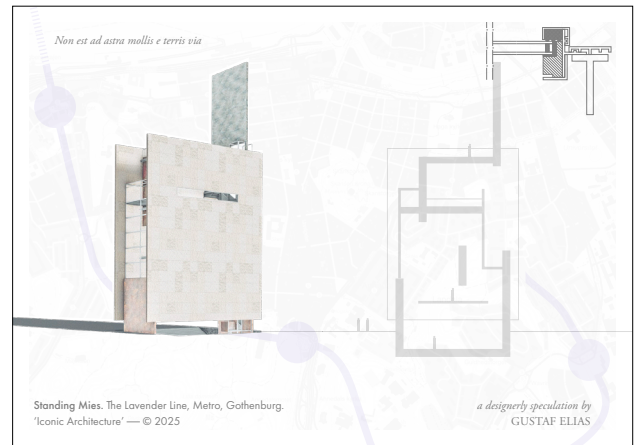

Fig A2-A3

### Lavender Line Postcards

Acheiropoieta expression in form of postcards and promotional imagery for the of the *Lavender Line* and *Standing Mies*. Front and back of card A (top), and front and back of card B (bottom), performed as actual postcards in a first edition of 100. (See also **section 7.6.**)

14,8x10,5 cm

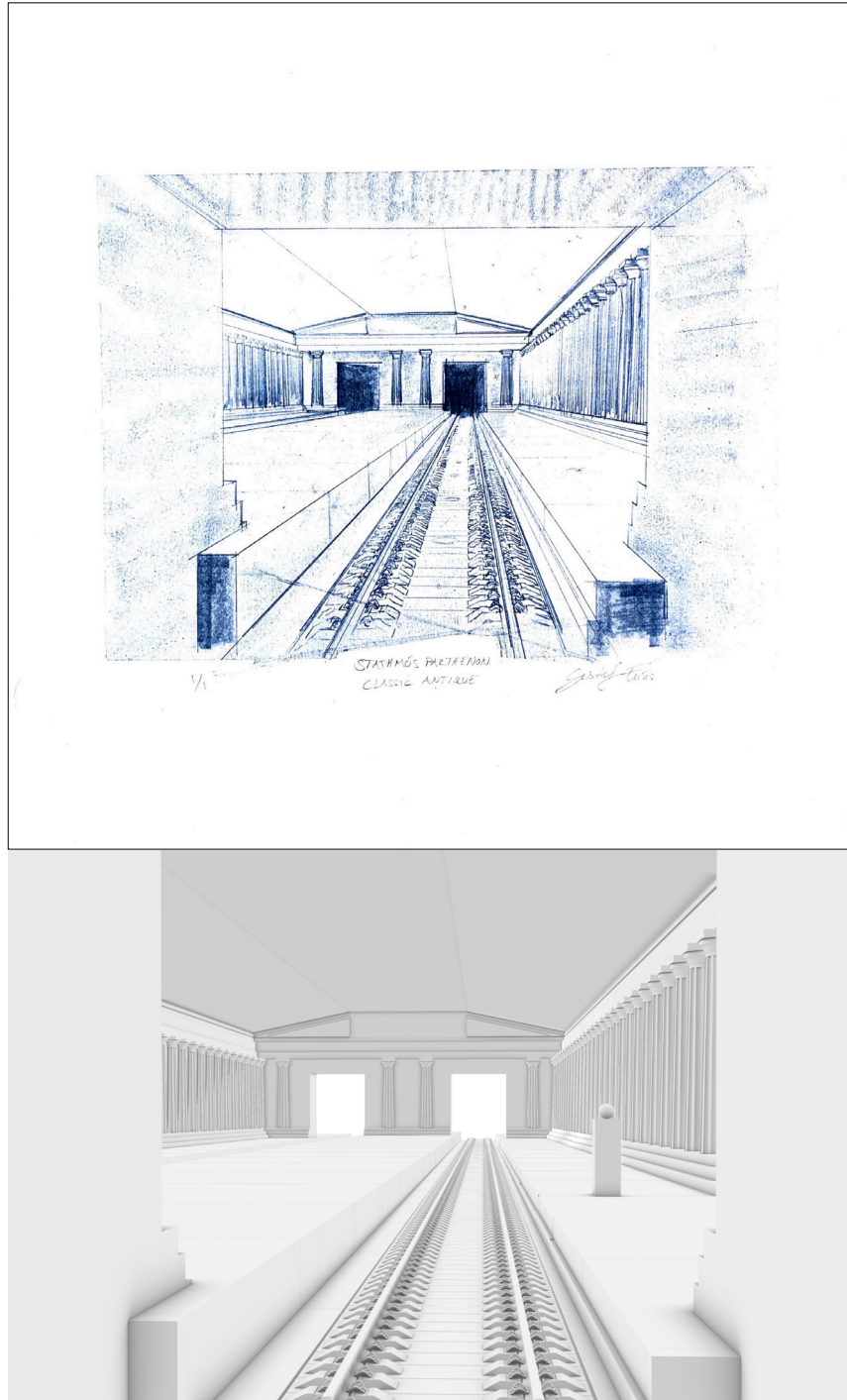

Fig A4

### Stathmós Parthenon Imprint

View from within the involution of an iconic expression and manifest.  
Could also be read as a render, interpretation, or image documentation and  
communication of the casted station autogram.

38x40 cm

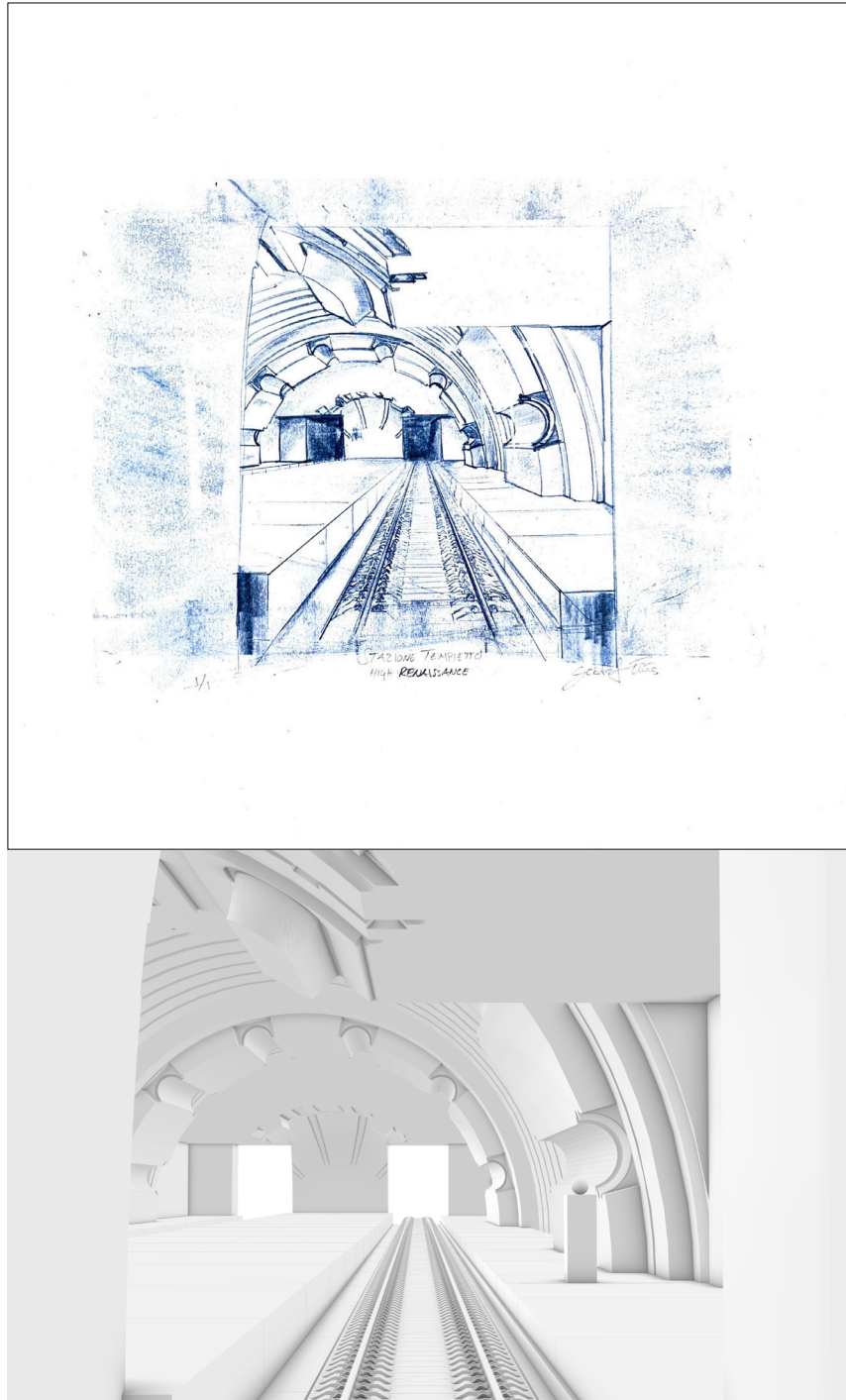

Fig A5

### Stazione Tempietto Imprint

View from within the involution of an iconic expression manifest. Could also be read as a render, interpretation, or image documentation and communication of the casted station autogram.

38x40 cm

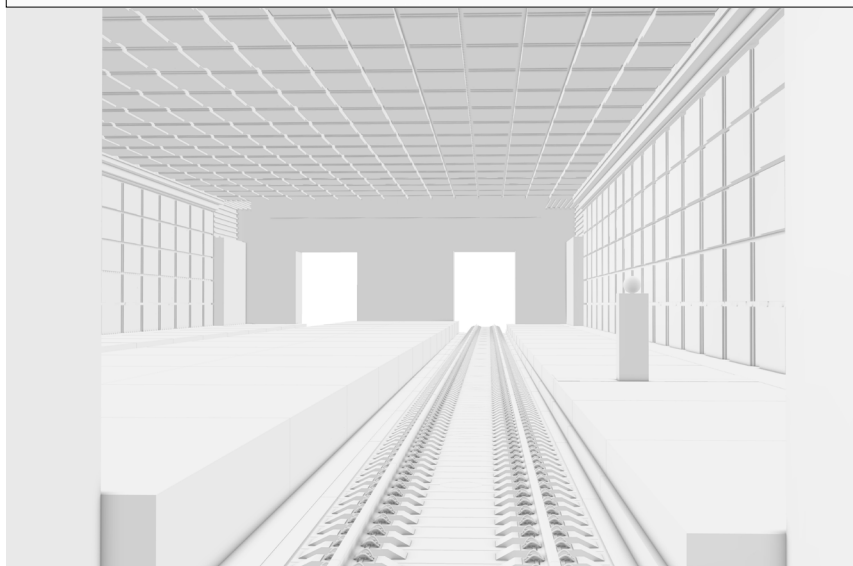
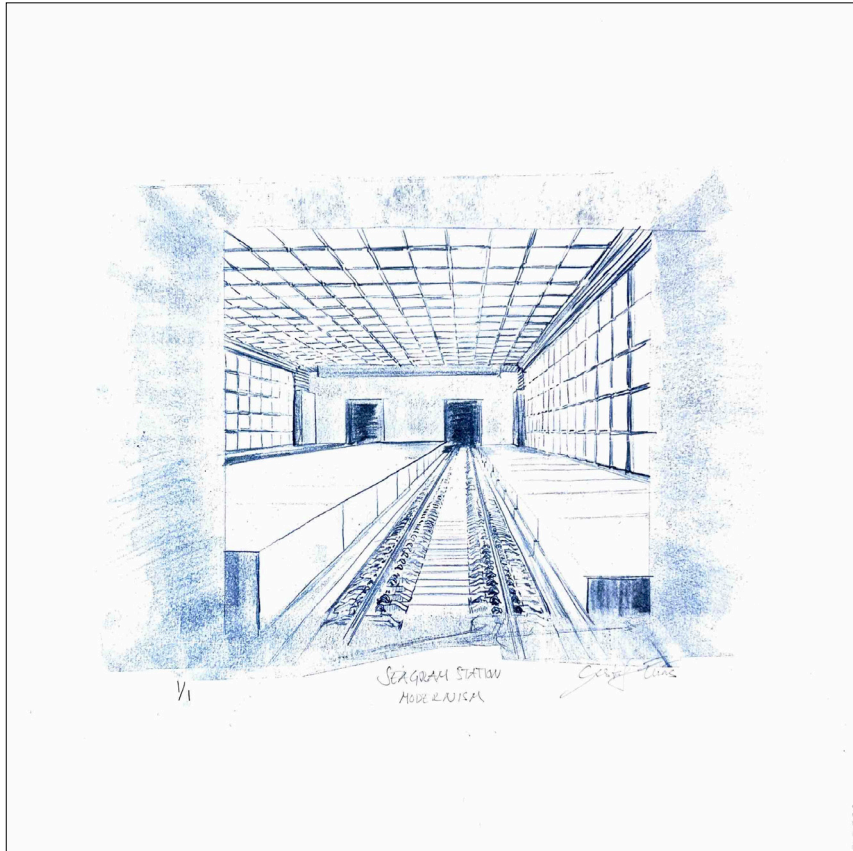

Fig A6

### Seagram Station Imprint

View from within the involution of an iconic expression and manifest.  
Could also be read as a render, interpretation, or image documentation and  
communication of the casted station autogram.

38x40 cm

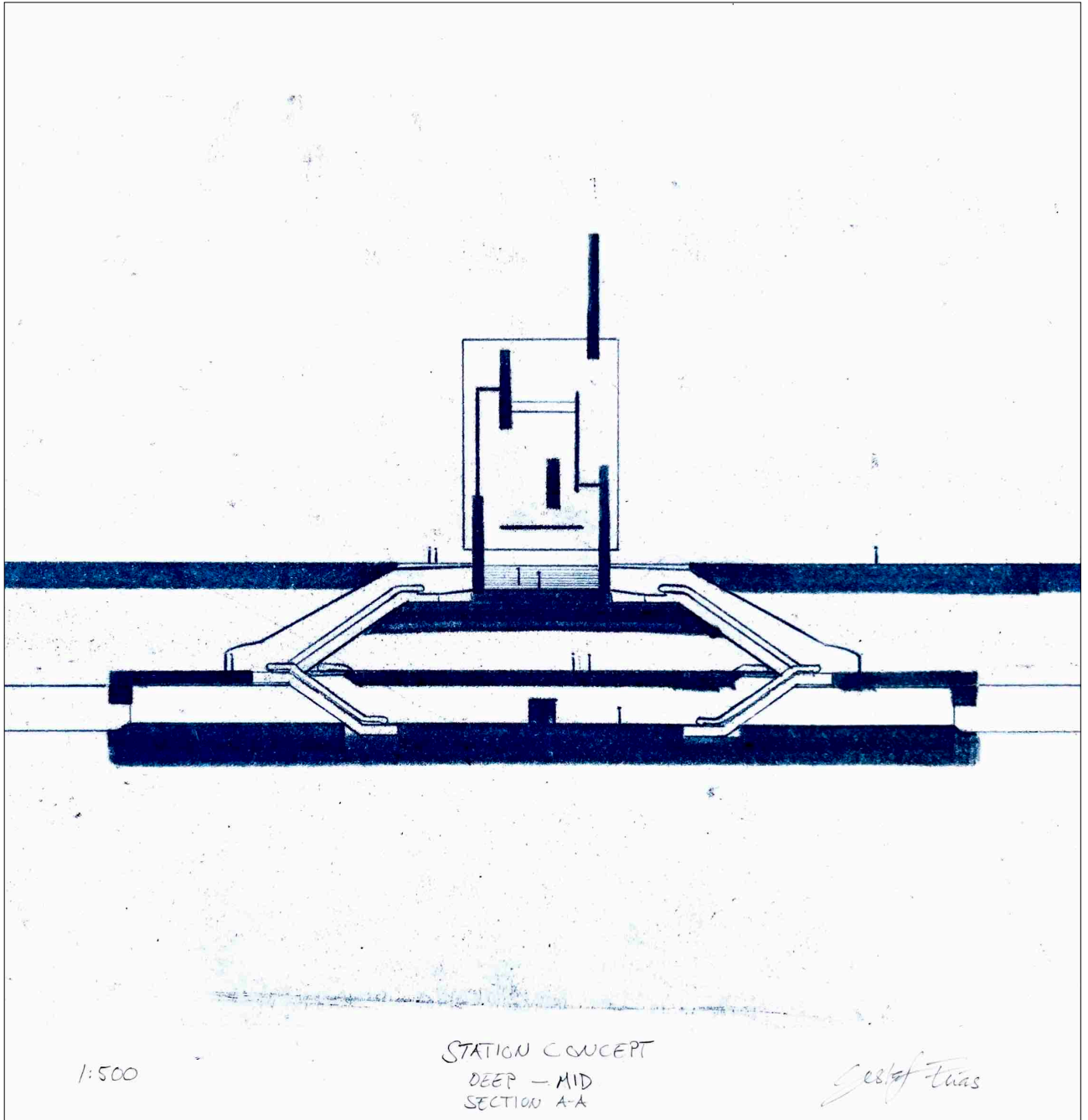

Fig A7

**Station Concept Deep Mid**

Longitudinal section AA-BB, scale 1:500.

38x40 cm

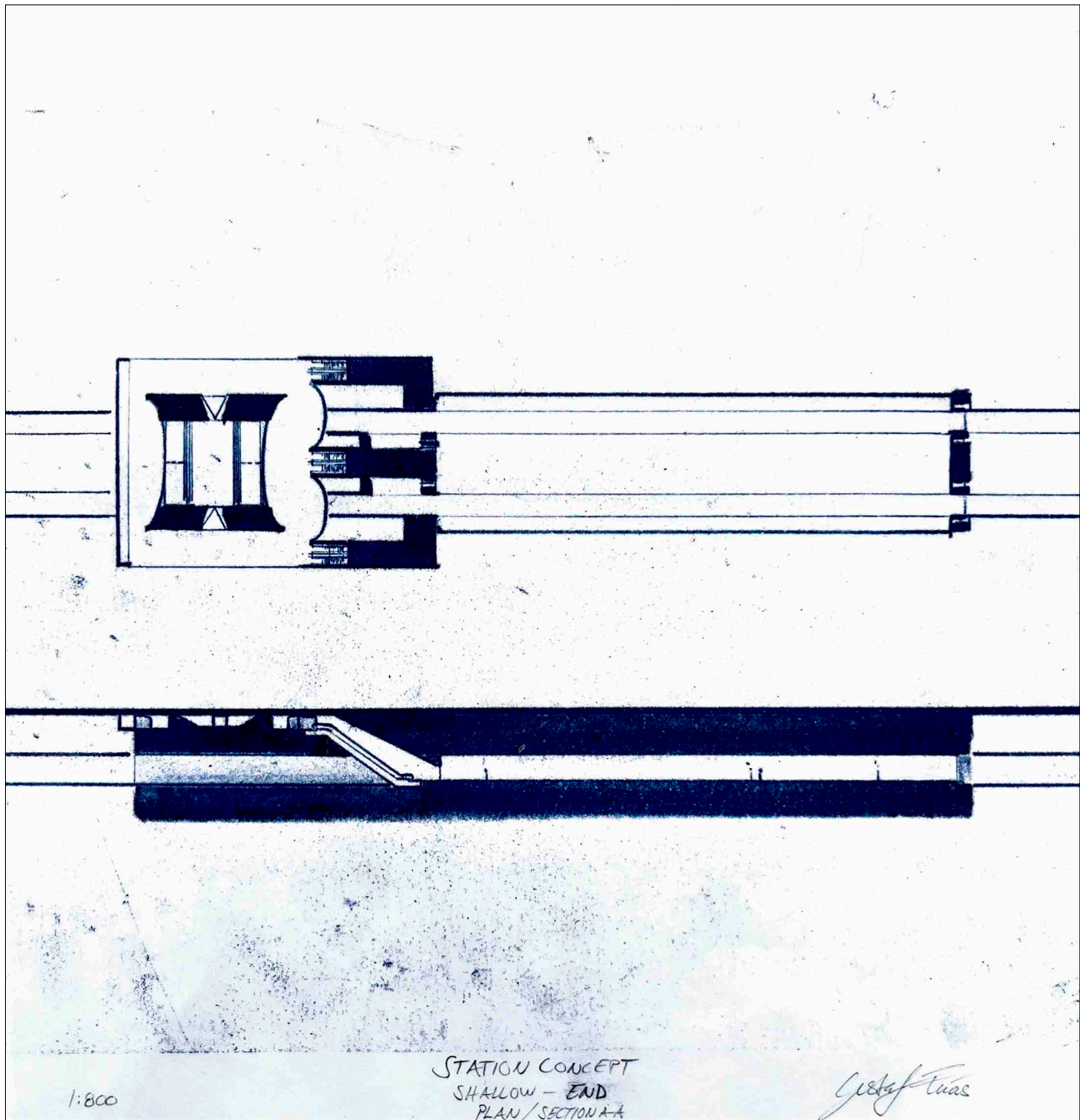

Fig A8

### Station Concept Shallow End Left

Plan and longitudinal section, scale 1:800.

38x40 cm

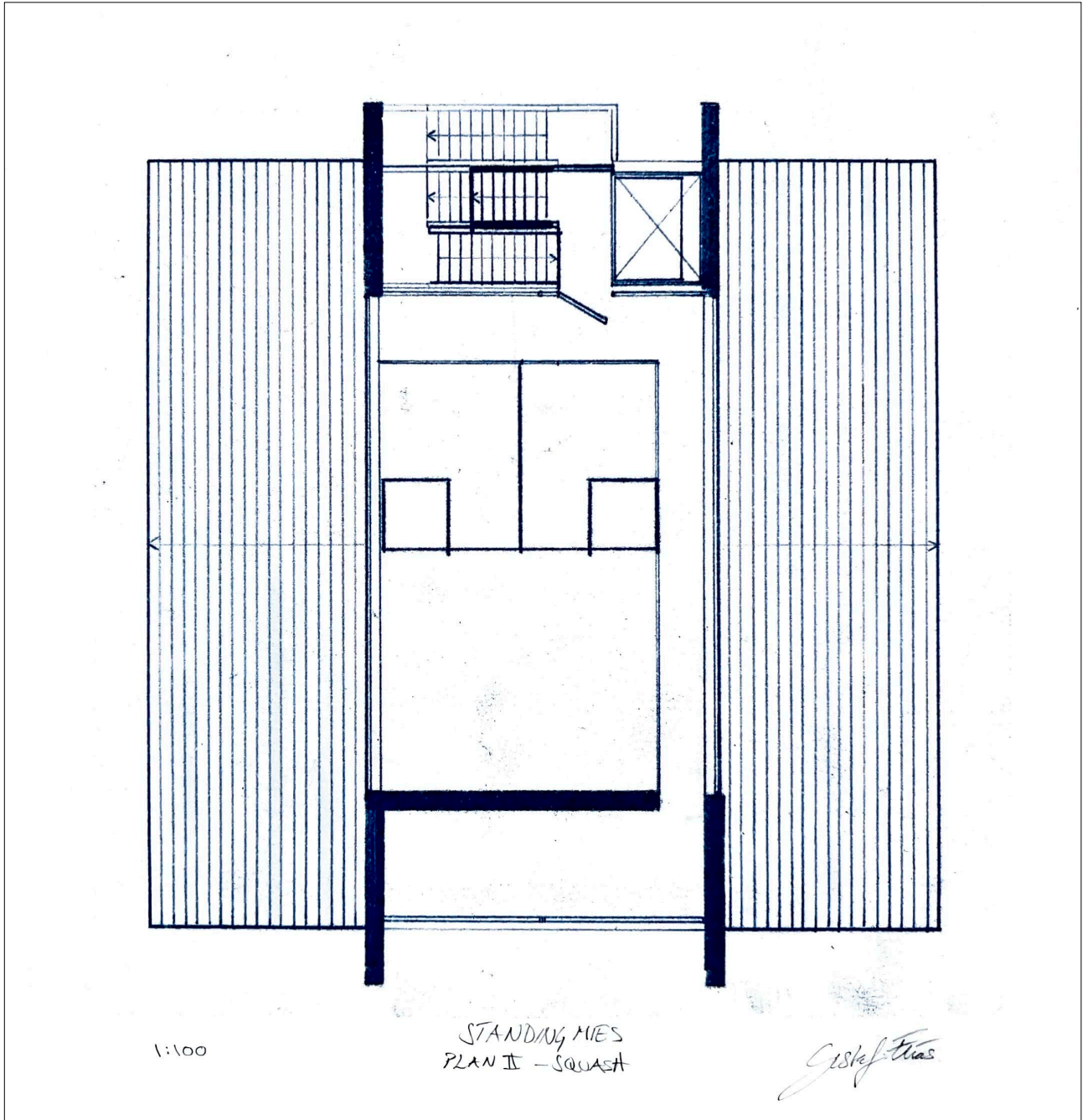

Fig A9

### Standing Mies Plan II Squash

Plan of the *Standing Mies*, second floor, fitted with a squash plan and private dressing room with panoramic view (lower room), scale 1:100.

38x40 cm

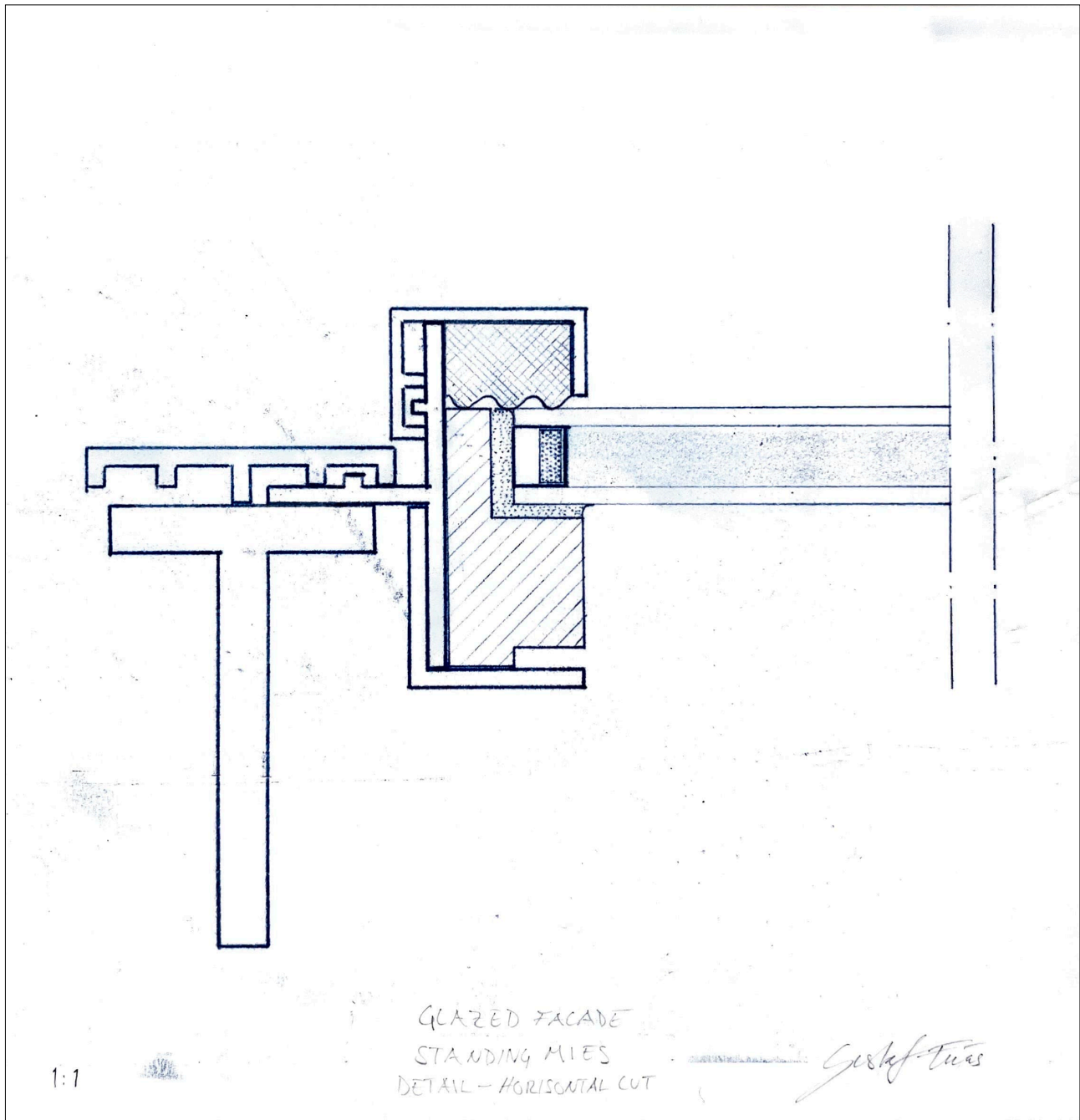

Fig A10

### Standing Mies Window Cut

Horizontal cut of principle detail for glazed facade and window framing of the *Standing Mies*, scale 1:1.

38x40 cm

See also the physical concept model (approx. scale 1:2) which is framing the *Standing Mies Artwork*.

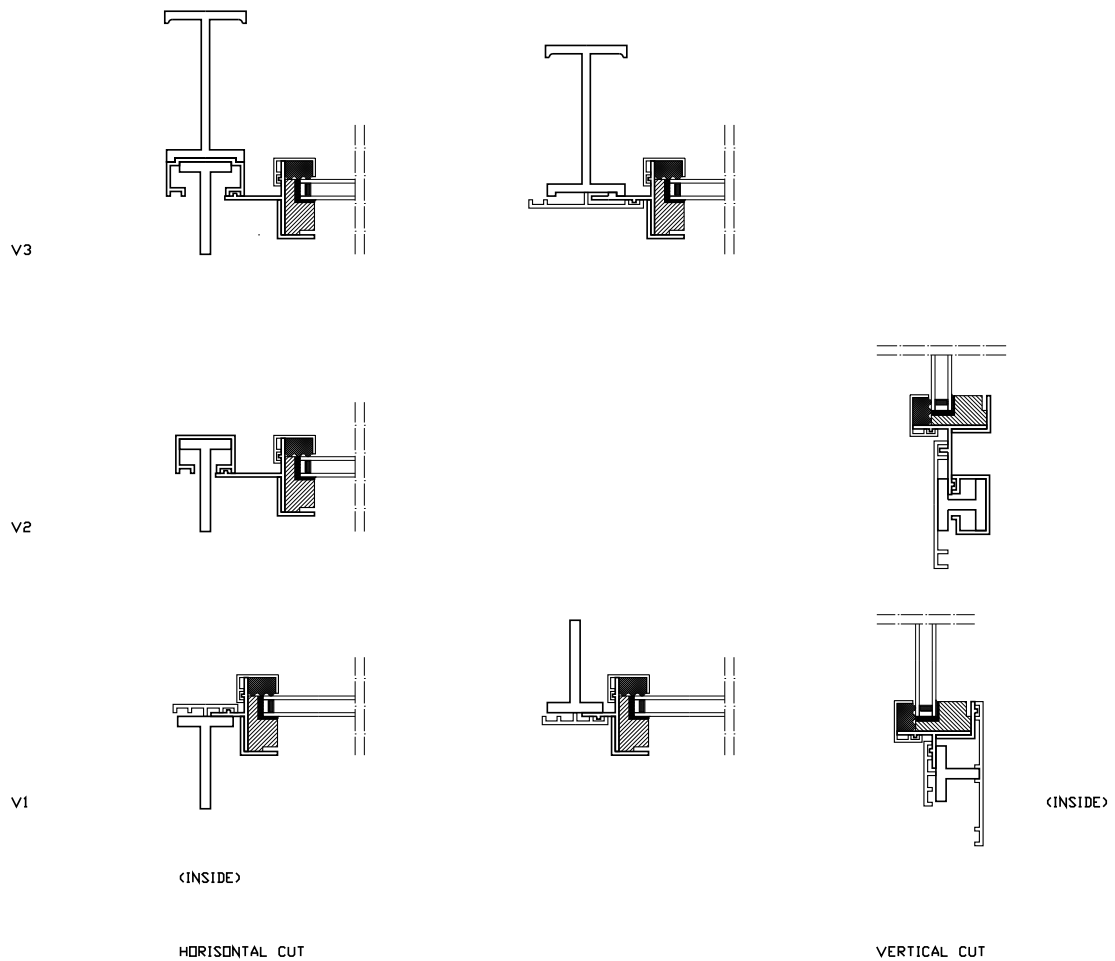

Fig A11

### Standing Mies Detail Matrix

Iteration matrix of principle detail for glazed facade and window framing of the *Standing Mies*, scale 1:3.

60x60 cm

Translation and reinterpretation of detail from Mies van der Rohe's Seagram Building (1958), merged with the Barcelona Pavillion (1929). First instance of version v3 (upper left) is the most like the original of Seagram Building. (See **Fig. 11-14, Appendix IV.**) An additional infill detailing in beech wood replaces the all bronze in original. Polished aluminum is used to imitate the chrome look of the Barcelona Pavillion. See also concept model (approx. scale 1:2) which is framing the *Standing Mies Artwork* (represented as digital artwork in **Fig. 18**; original artwork is in oil on gesso primed hemp paper, 60x60 cm).



(1) Stathmós Parthenon



(2) Stazione Tempietto



(3) Seagram Station

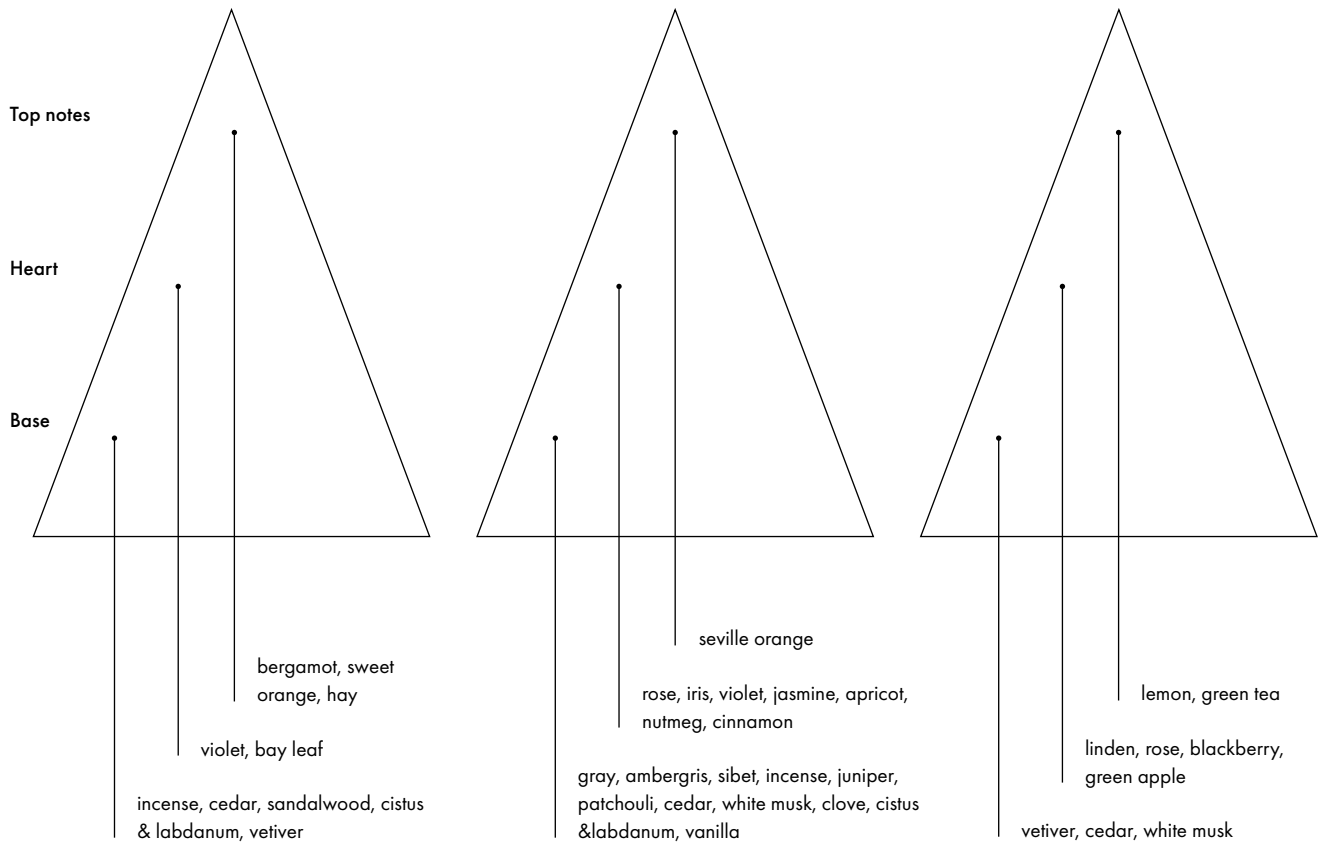

Fig A12-14

### Lavender Line Eau de Parfum x3

Scents designed as perfumes, which primes the casted models/autograms, and expands the iconic visuality of the architecture.

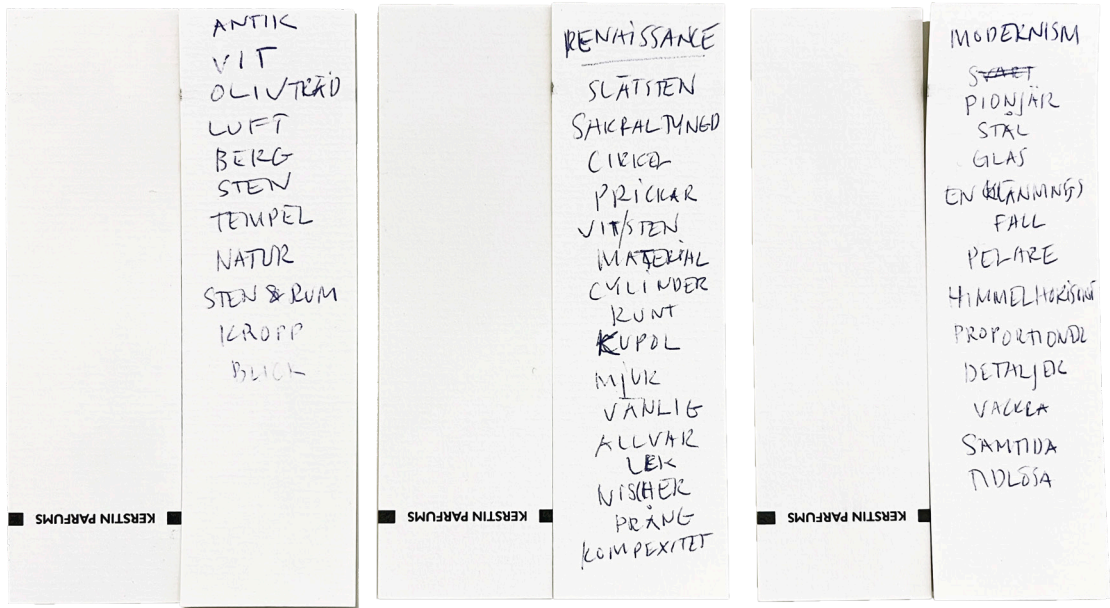

Fig A15-17

Testers during the development of the perfumes, sprayed with the base notes and annotated with key textual notes of the scents (top).  
The *Lavender Line Collection* as postcard (bottom).



Fig A18-20

**Standing Mies Model**

By night. Scale 1:87.

Baseplate 30x30 cm.

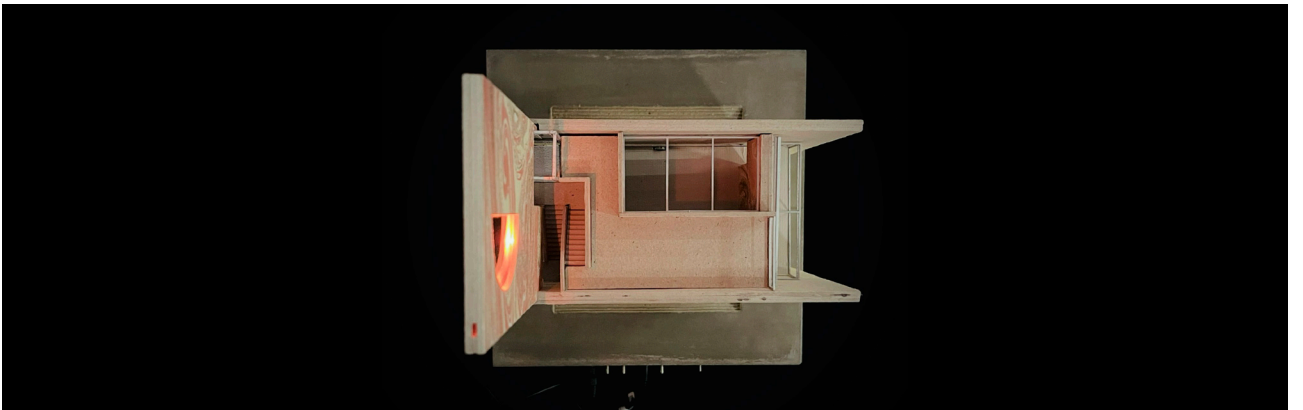



Fig A21

**Standing Mies Model Section**

By day, in exhibition. Scale 1:87.  
Baseplate 30x30 cm.

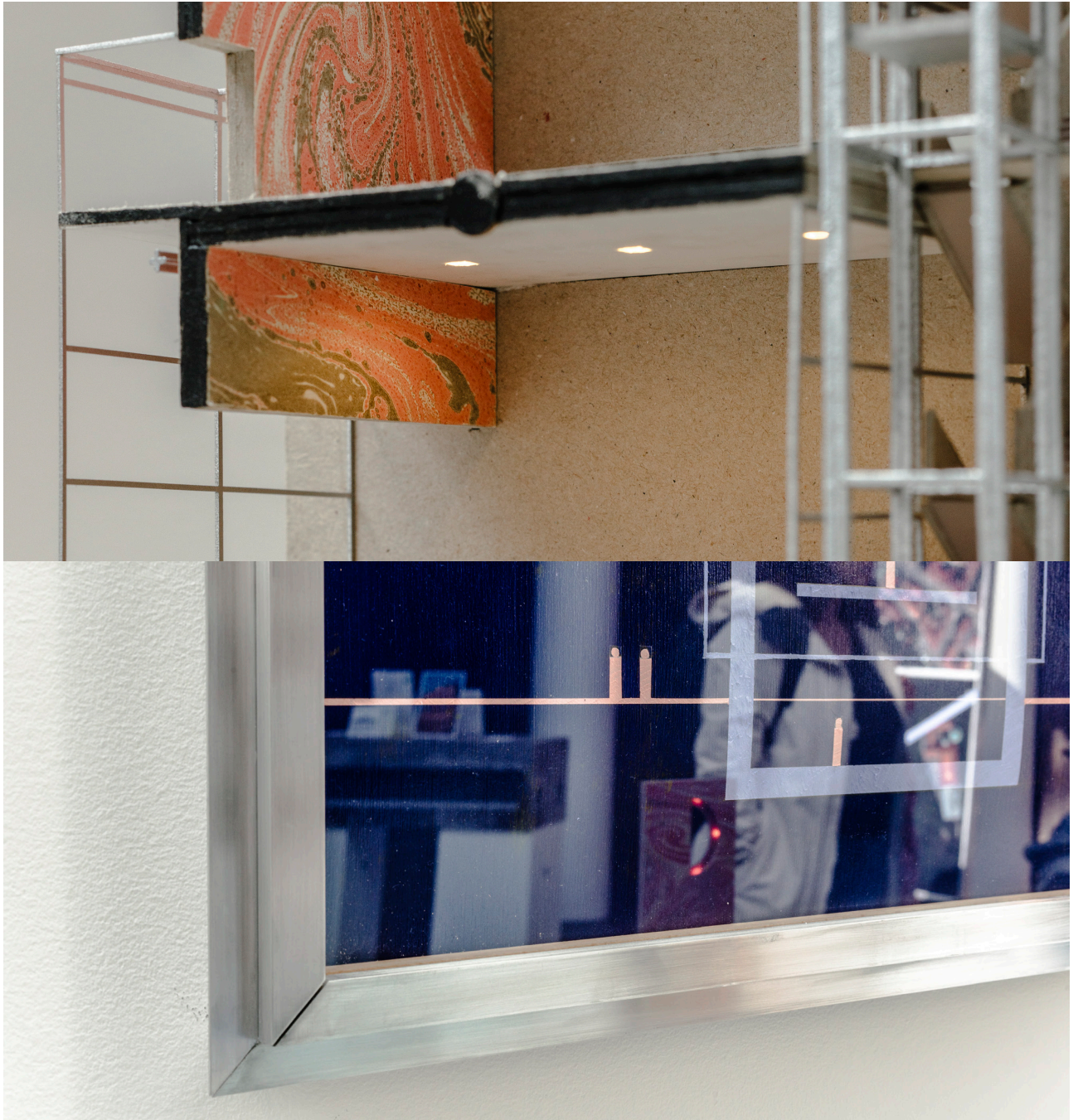

Fig A22-23

**Casted Autograms (Lavender Line Stations)**

Standing Mies model, detail (top).

Autogram and concept model of principle detail for glazed facade and window framing of the *Standing Mies*, acting as framing for the *Standing Mies Parti Artwork* in exhibition. Aluminium and beech wood (bottom).

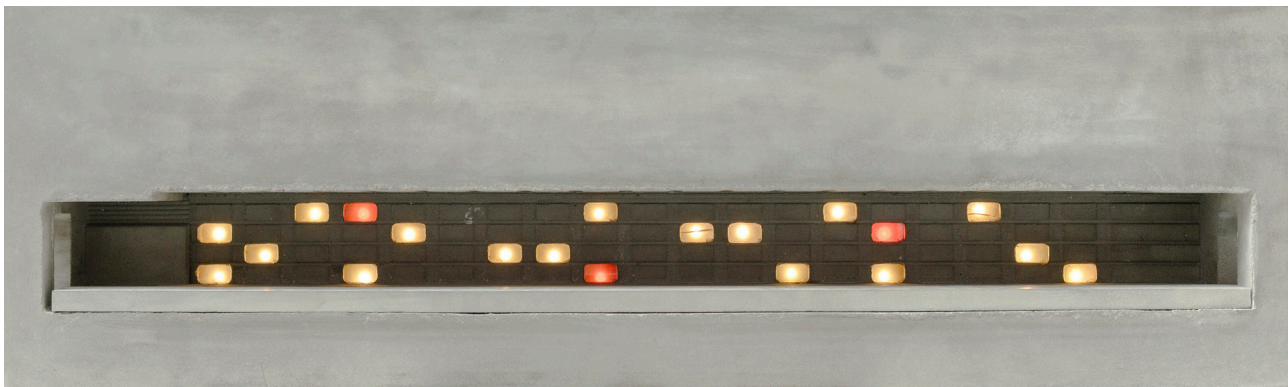
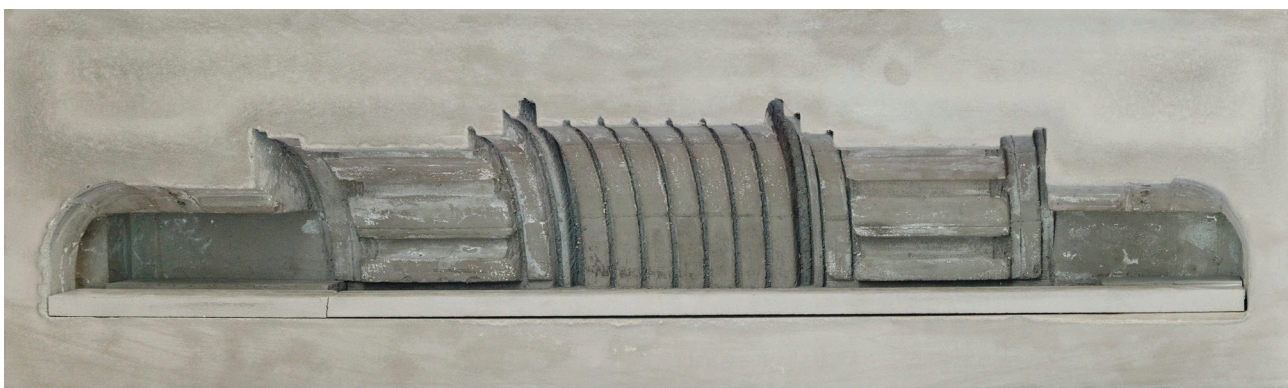

Fig A24-26

**Casted Autograms (Lavender Line Stations)**

Self-leveling concrete. 914x270x164 mm. Scale 1:87.

Stathmós Parthenon [Classic Antique] (top)

Stazione Tempietto [High Renaissance] (middle)

Seagram Station [Modernism/International Style] (bottom)

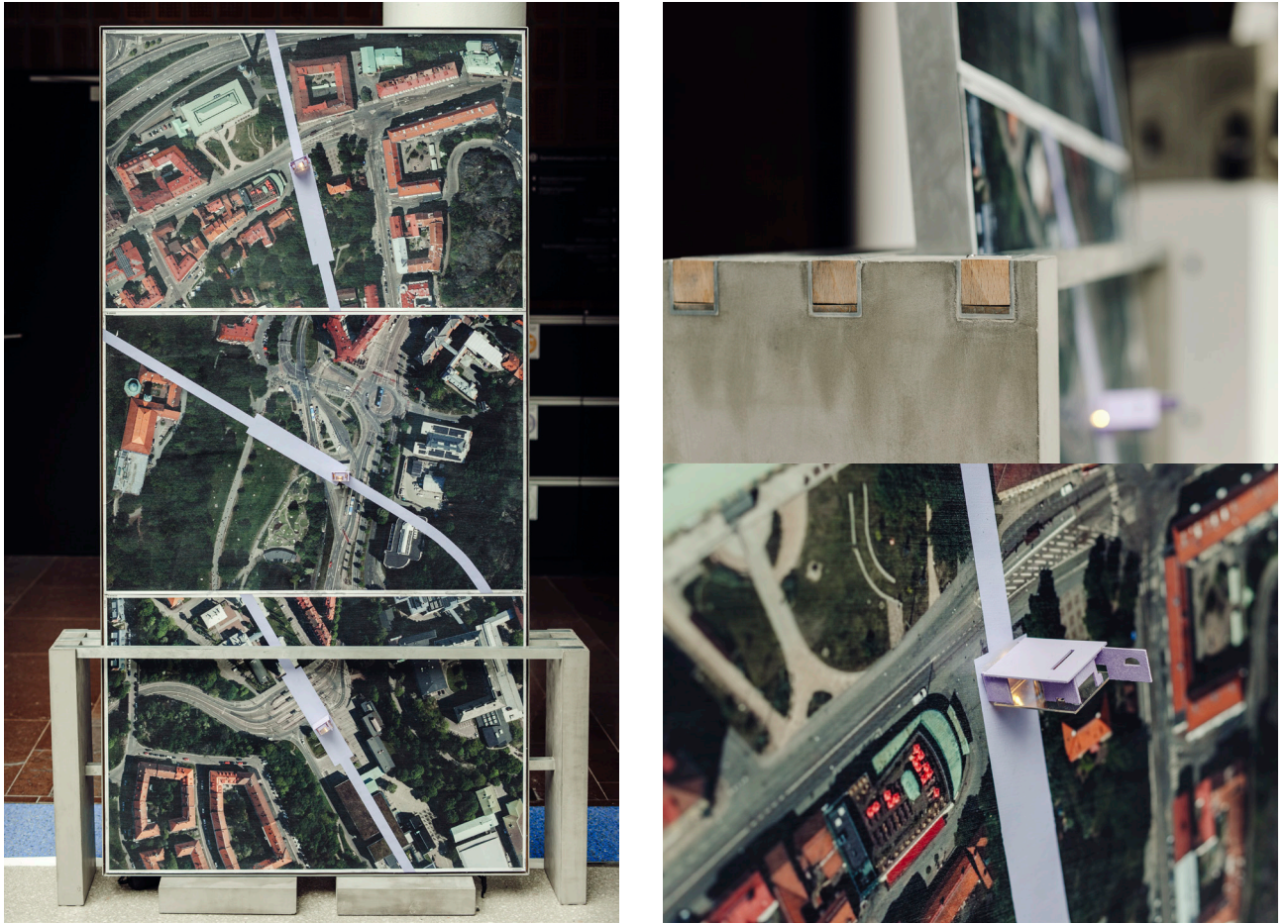

Fig A27-29

### **Lavender Line 3D Site Map**

With station bench prototype. Aluminium profiles, self-leveling concrete, beech wood, gesso primed pigment on paper, oil paint, cardboard, acrylic glass, SMD-LED:s. Scale 1:500.



Fig A30-33

**Iconic Architectur [fragments]: in exhibition**

Autograms and acheiropoiet in exhibition. Chalmers School of Architecture, 5-12 June 2025.

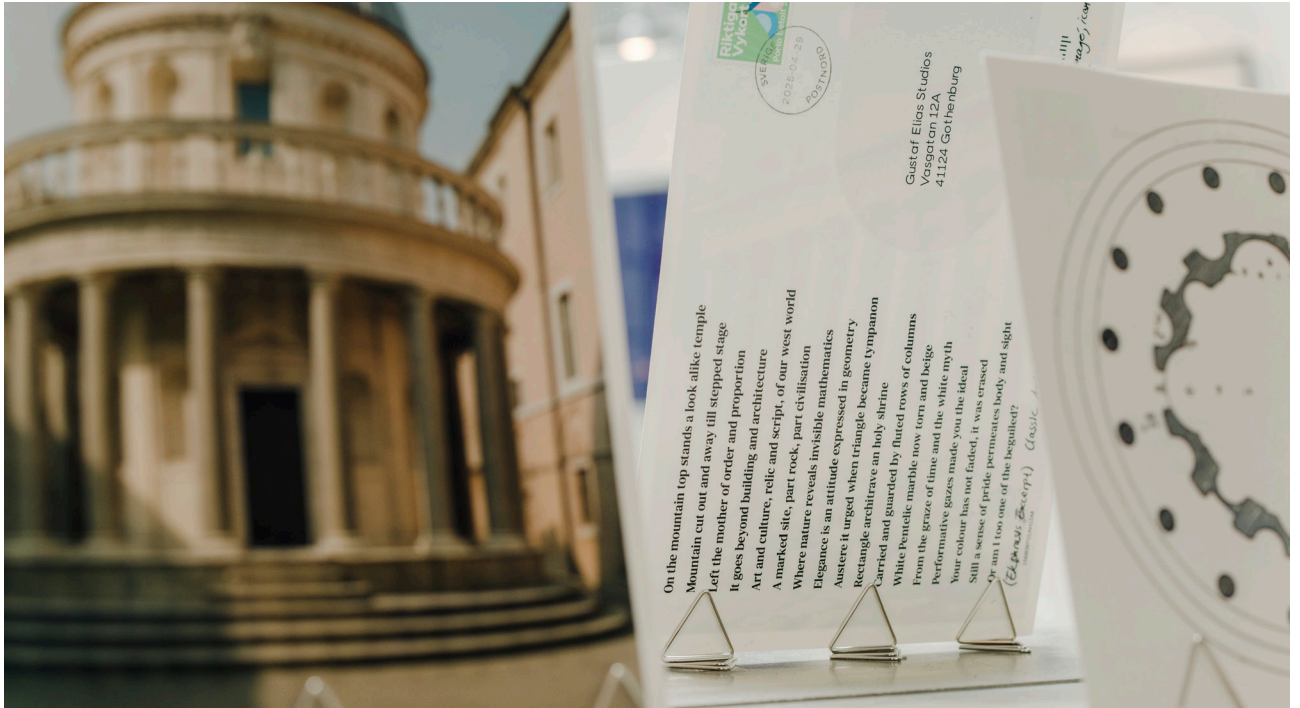



## APPENDIX IV

### FIGURES

#### Compilation of Figures, Pictures and Visuals

The figures presented parallel to the text in *The Booklet* are here presented in large. In compilation with process pictures and complementary visuals.



Fig 1

**Parthenon by ChatGPT**

Image rendering by ChaGPT from prompt; asking for iconic image of Parthenon. Used for spatial translation.

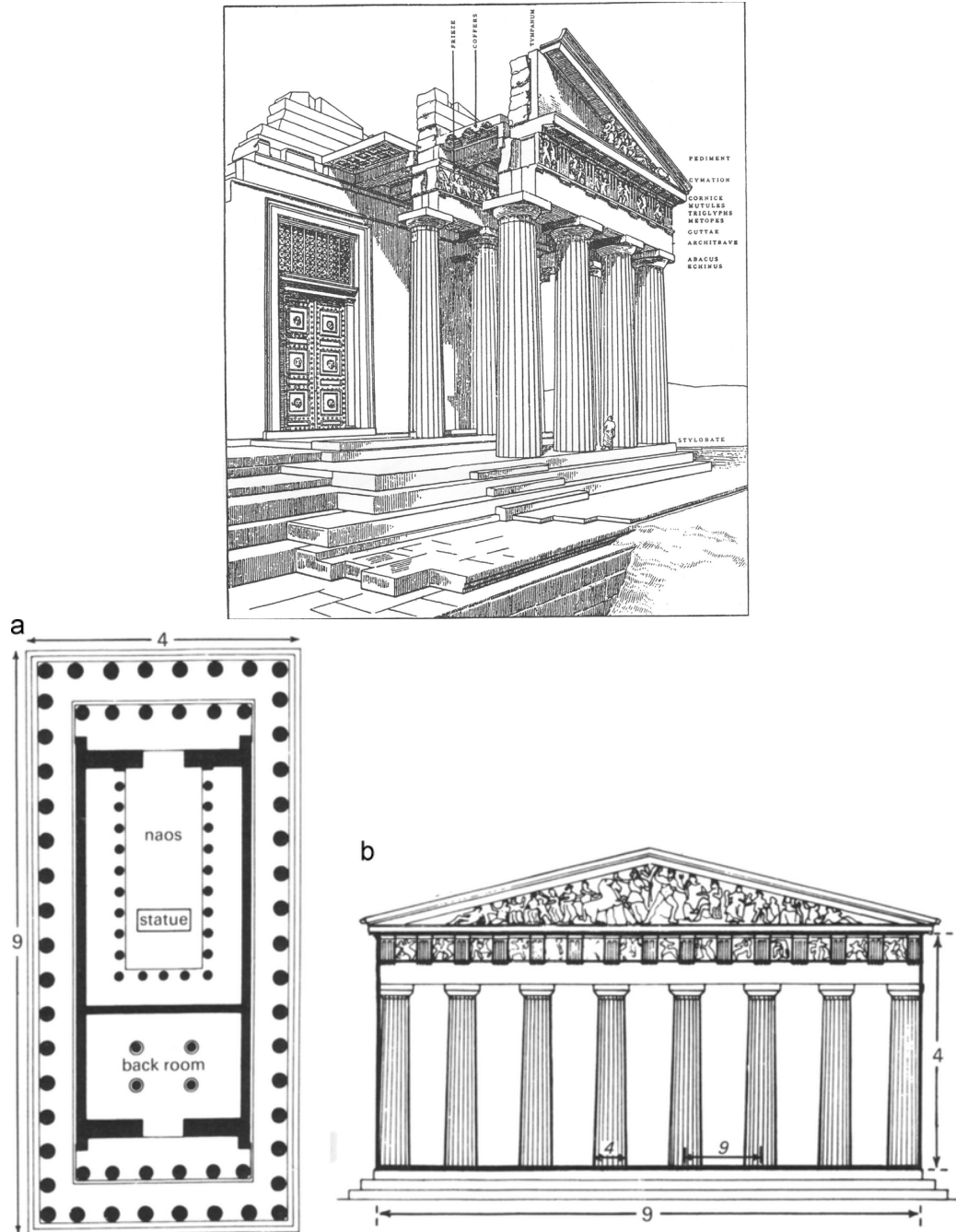

Fig 2 (top). Fig 3 (bottom).

### Iconic Drawing of Parthenon

Disclosing proportions and composition of classic Architectonic Elements. Perspective section (top); Plan and elevation (bottom); Parthenon, 447-432 BCE., Iktinos and Kallikrates Athens, Greece.

In: Lu, Fangqing. (2016). Architecture as spatial–textile storytelling: Metamorphosis of frieze as a narrative medium mediating the Panathenaia festival. *Frontiers of Architectural Research*, (5), 489-498. Used for spatial translation.

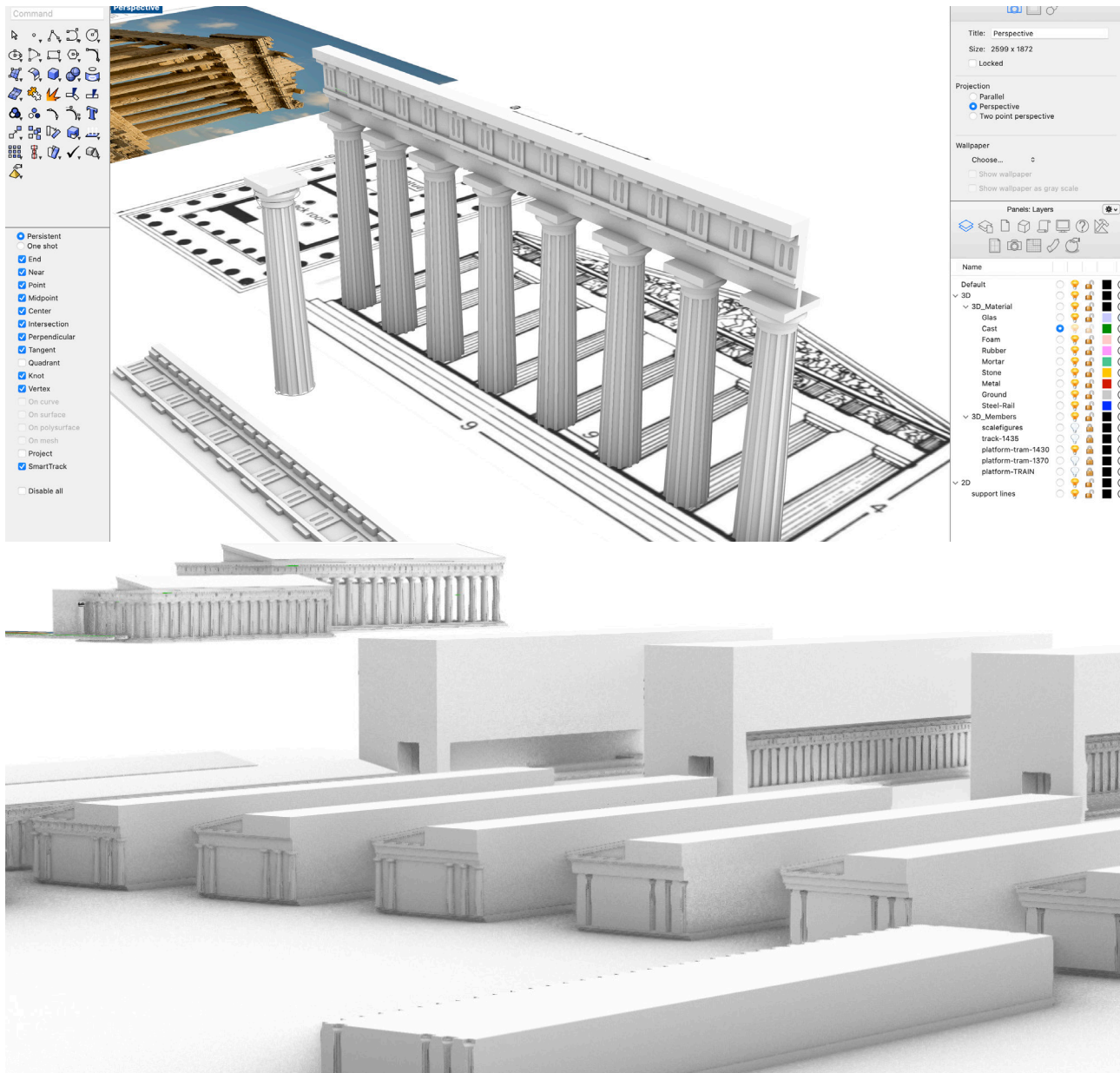

Fig 4  
**Parthenon Translation and Iteration Sequence**

Spatial translation from imagery. Note that the frieze initially was modeled with triglyphs, though omitting the detailing of the metopes. The cornice was modeled with the dentil row in its bed mould. The final entablature was later simplified in a sequence of iterations, due to the scale factor in the following model reproduction. Focus was put on height proportions and relief depths of the different vertical levels of the entablature, instead of all sculptural features. Maintaining an iconic likeness, while in a purified form.

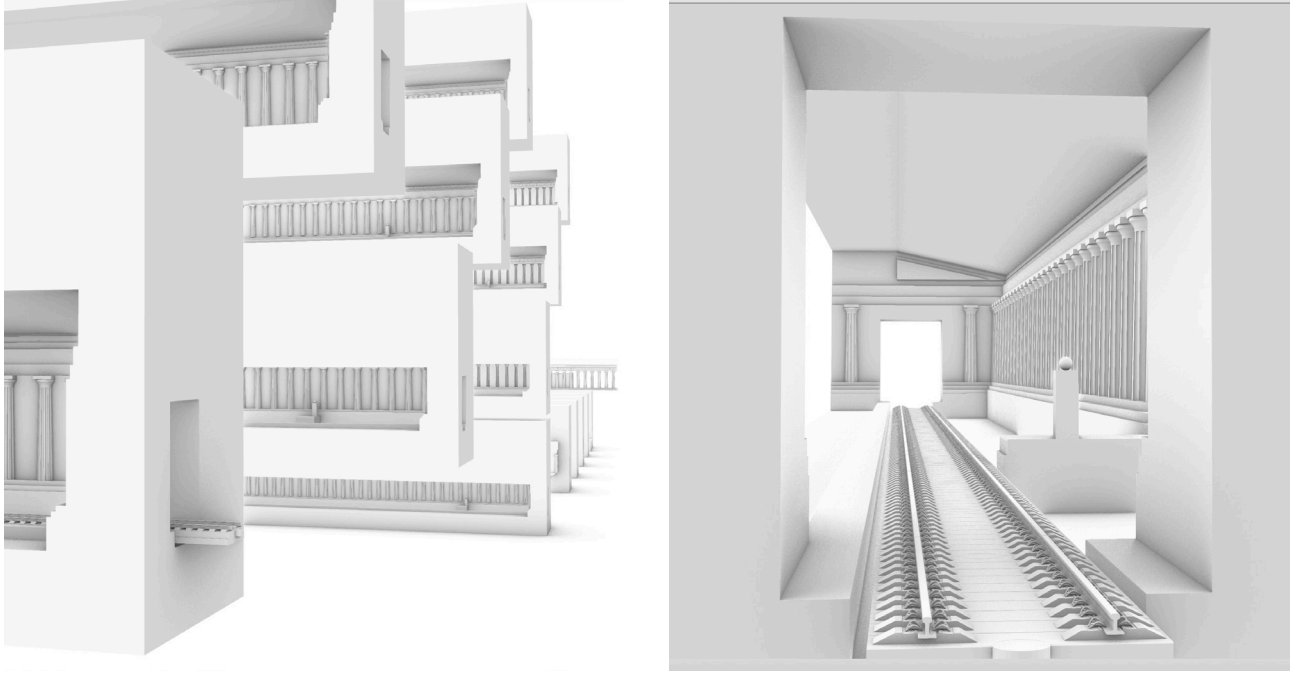

Fig 5

### Parthenon Debossing, Embossing, and Scaling

The final sequence of iterations reversed the outset concept of the translated building envelope making a negative debossing in the station space. The deboss was kept for the entablature, tympanon and roof, but for the columns and platforms serving as steps up towards the rows of columns an inversion was chosen, turning the imprint into a positive embossing instead. The scale factor of the short ends and height was scaled with a factor 1:2, also keeping the small original increase in column distancing towards the center; an optical illusion invented by the Greeks to make the temple seem level and more harmonic. While the long side is extended with added columns fitted with equal distancing in the middle to fill the total length of the station.



Fig 6 (left). Fig 7 (right).

### Tempietto by ChatGPT

Image Renderings by ChaGPT (2025-04-03) from prompt; asking for abstracted image (left) and iconic image (right) of Tempietto. Used for spatial translation.

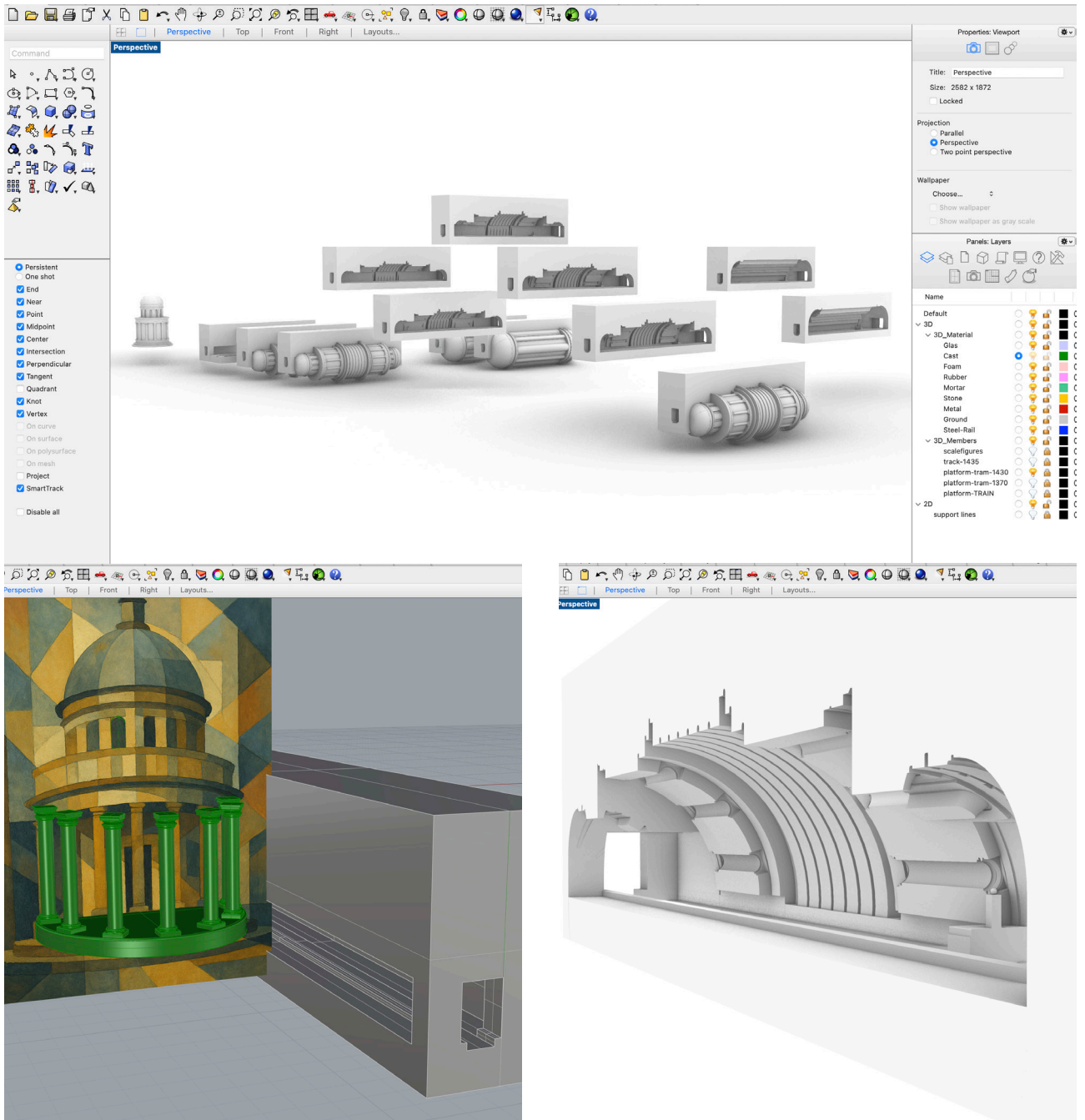

Fig 8

### Tempietto Iteration Sequence I

Spatial translation from rendering by ChatGPT. Translated design put in horizontal position and mirrored from its discs previously constituting fundament, now in center. Modeled scaleless, with focus only on proportions according to image, and length x2 to fit the length of the concept station's base cavity.

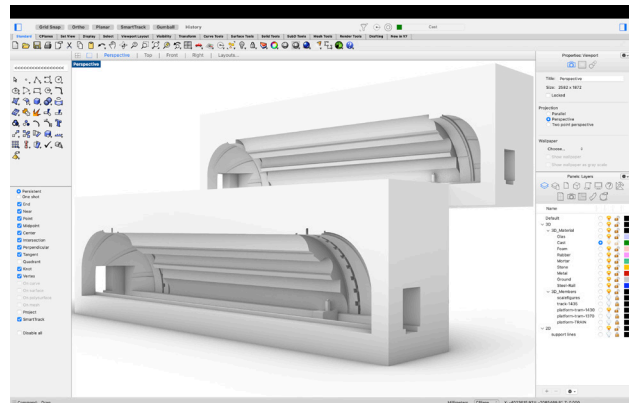
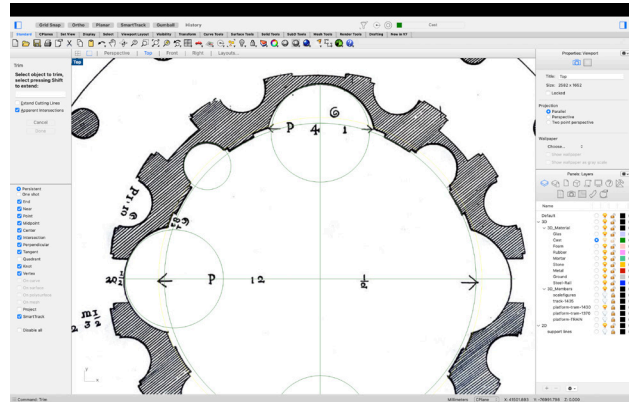
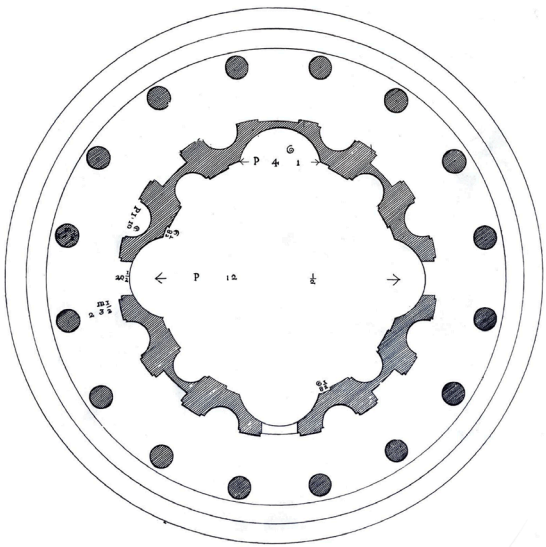

Fig 9 (left). Fig 10 (right).

### Tempietto Iteration Sequence II: Palladio Plan Extrusion

Plan of Tempietto del Bramante (left), Rome, drawing by Andrea Palladio (1508-1580). In: Palladio, A. (1965[1738]). *The four books of architecture*. Translated into an extruded lateral cavity and spatial situation (right). Though being a more intriguing and not as obvious iconic translation, this iteration sequence was discarded in favour of the first. The former iteration presenting a more intriguing final space with more intricate and dynamic room heights as one move lateral through the space.

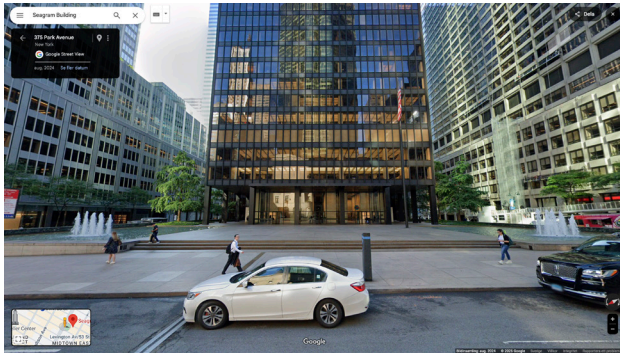

Fig 11 (left). Fig 12 (right).

### Seagram Building in reality and by ChatGPT

Screenshot from Google Maps Street View (2025-04-16) (left) and render by ChatGPT (2025-04-04) from prompt, asking for iconic image of Seagram Building (right). Example of the glitched translation process between “reality” and “iconic” or “collective image”.

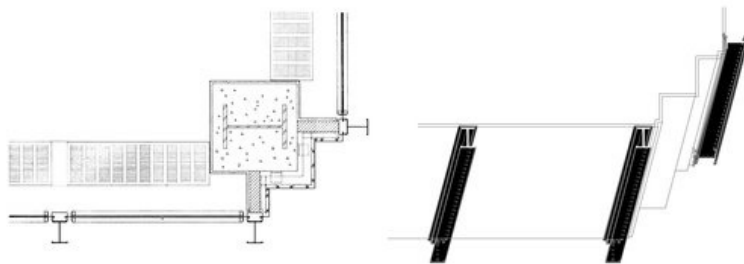
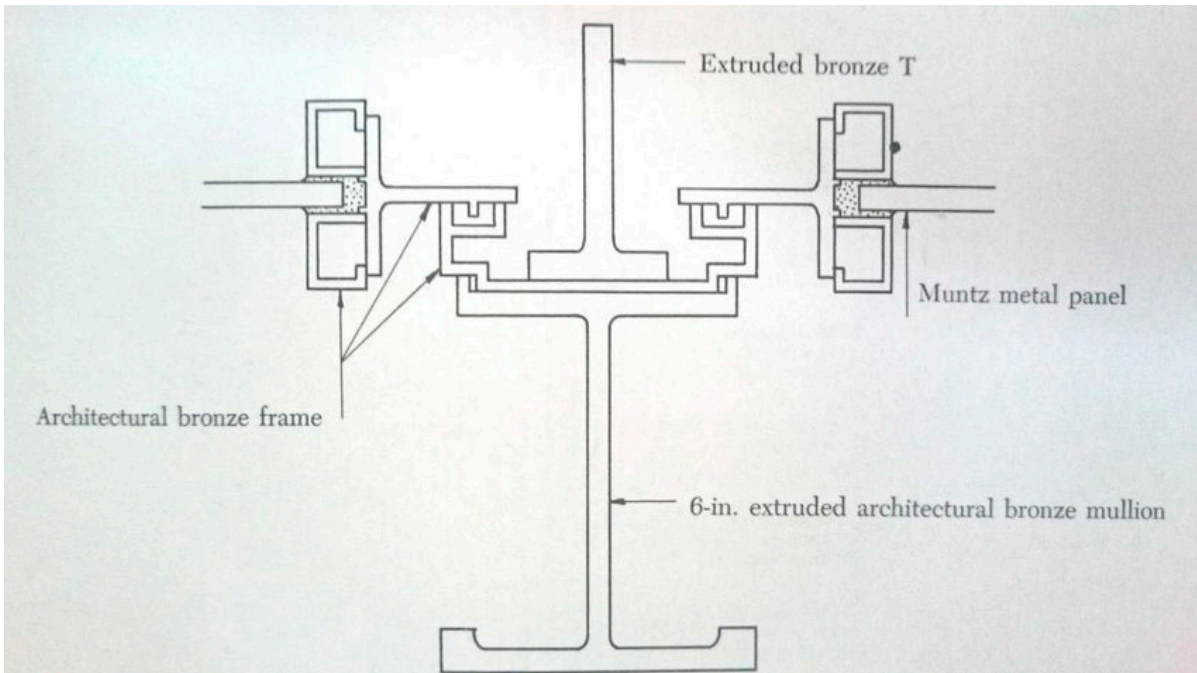

Fig 13 (top). Fig 14 (bottom).

### Most Recurring Drawing of Seagram Building

(Top) Detail I, Seagram Building, 1958, Ludwig Mies van der Rohe, New York City. In: Čakarić, I. (2017). *Facade Installation Optimization*.

(Bottom) Detail II, Seagram Building, 1958, Ludwig Mies van der Rohe, New York City. In: Kostić, M. (2020). *Functional Excess: Ornamentation in the Post-Fordist Production and Projection of Architecture*.

The image down left is a very recurring image and drawing of Seagram Building in Google image search, and thus part of the “collective image”.

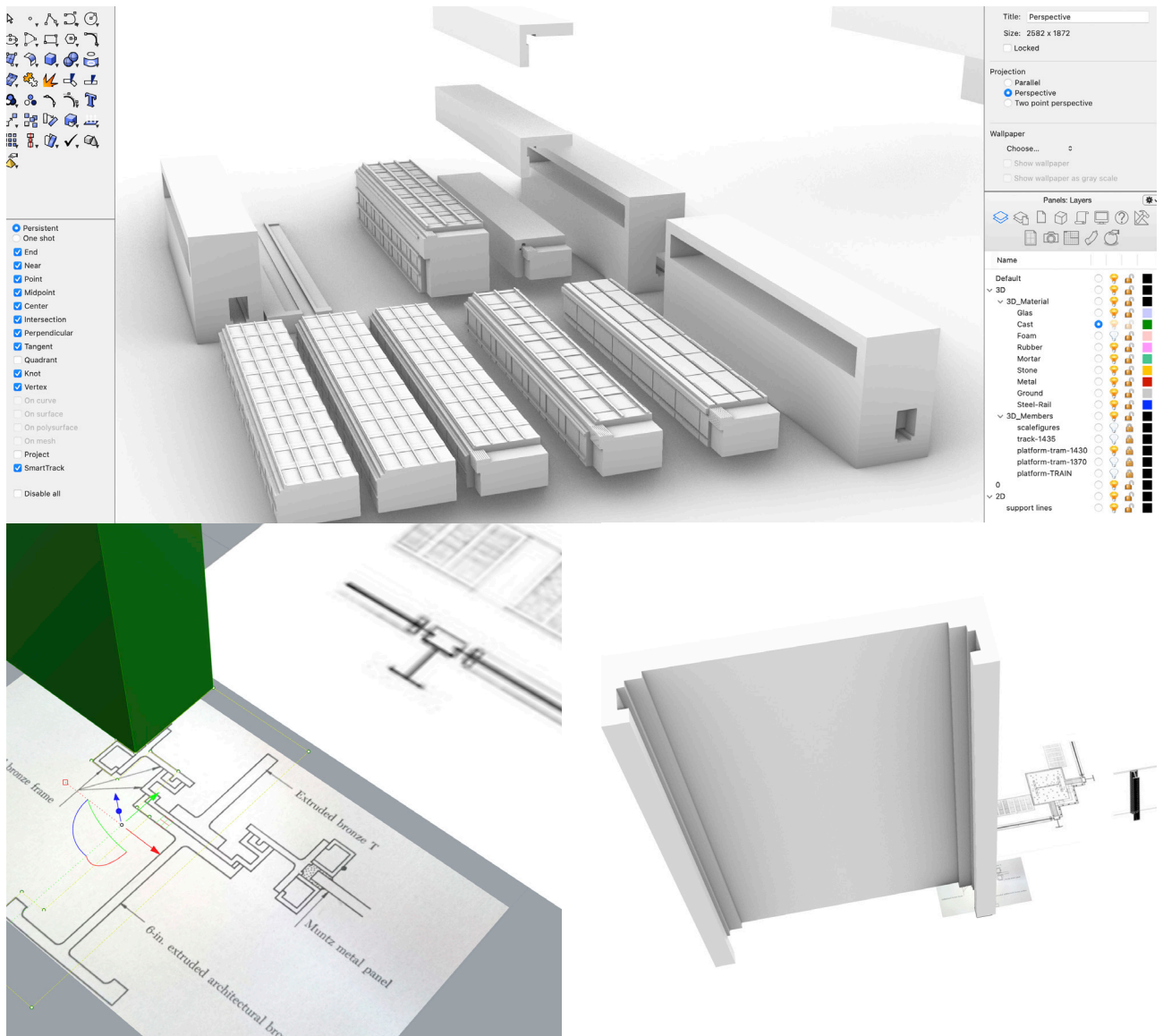

Fig 15  
**Seagram Building Translation and Iterations**

Spatial translation from imagery. By the look of it the most simple and repetitive case, though it presented the most translation iteration, design choices and challenges. This building is about the detailing, creating its iconic imprint and mass effect; reflected in the one very frequently recurring detail drawing, i.e. *not* a plan, nor section or elevation. Translation here lies in the interpretation of the details, and how much of their intricacy that is reduced in scaling and image making. The window translation were tested with a scale factor of 2:1, then 3:1, before finally settling for 1:1, to get the most out of the mass effect of their repetition. Though keeping the partially visible one column in approx. scale 3:1. The final modeled envelope was put into a horisontal position, turning the original skyscraper's verticality into a horisontality.

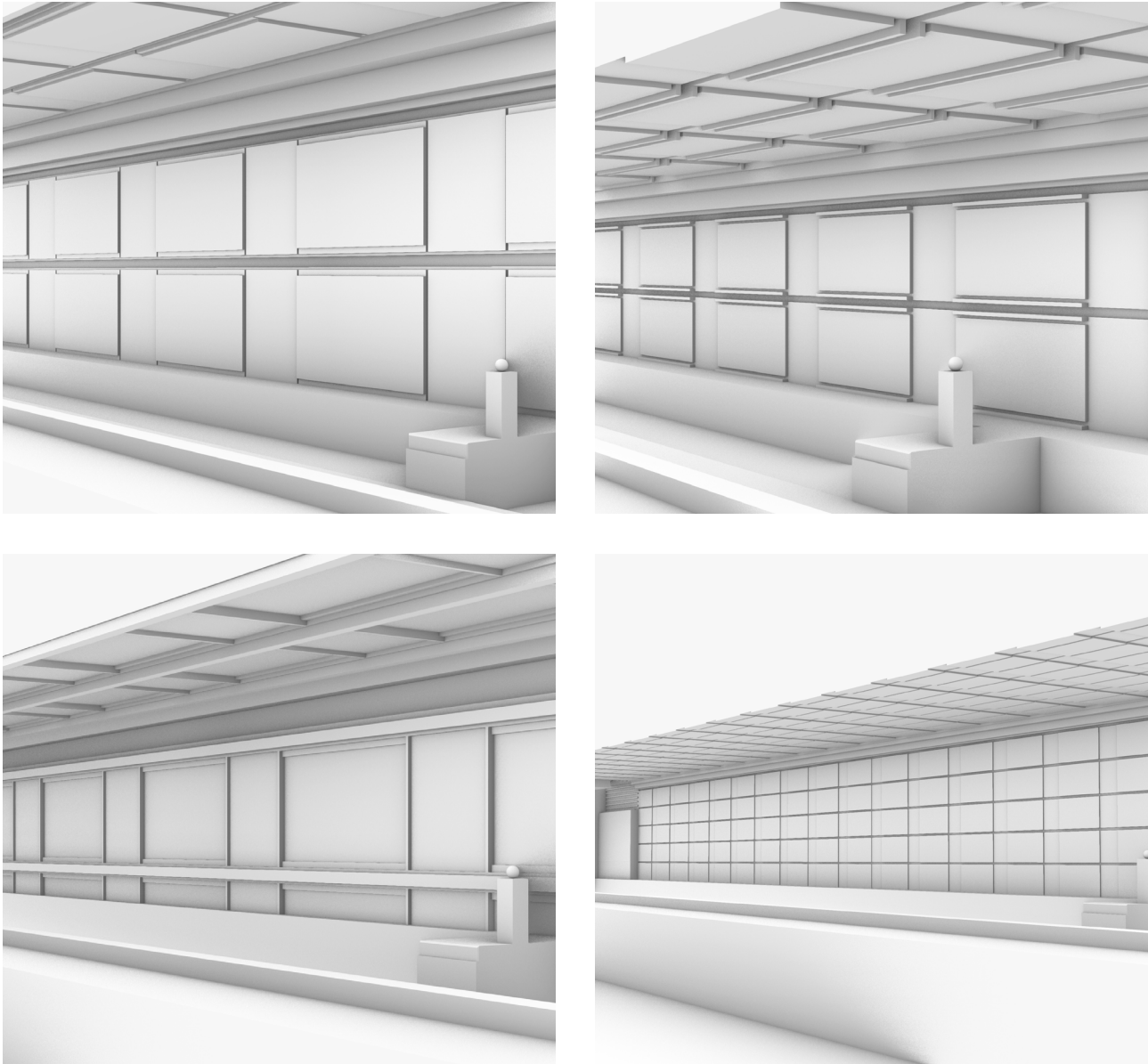

Fig 16

### Seagram Building Deboss, Emboss, and Details

The translation of detailing and their sometimes poor resemblance with the prompted “iconic image” from ChatGPT as well as the “iconic drawing” when turned into a debossed pattern, made the translation process into a freer interpretation with a aim to gain more resemblance and likeness with the “iconic” idea and image. The uppermost figures show two freer iterations with a factor 2:1. The lower left an iteration with an inversion into an emboss in factor 3:1. The lower right shows the close to final iteration with a deboss in scale factor 1:1 and a distinct purification of detailing. Though the partially visible column in the upper far left corner, is kept in a factor of 3:1 with its detailing of subtle fluting, to highlight the reminiscence of fluting in classic antique columns.

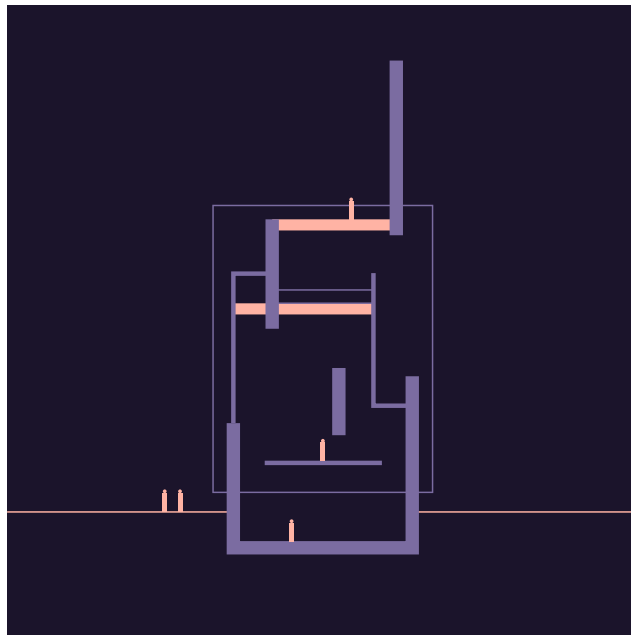
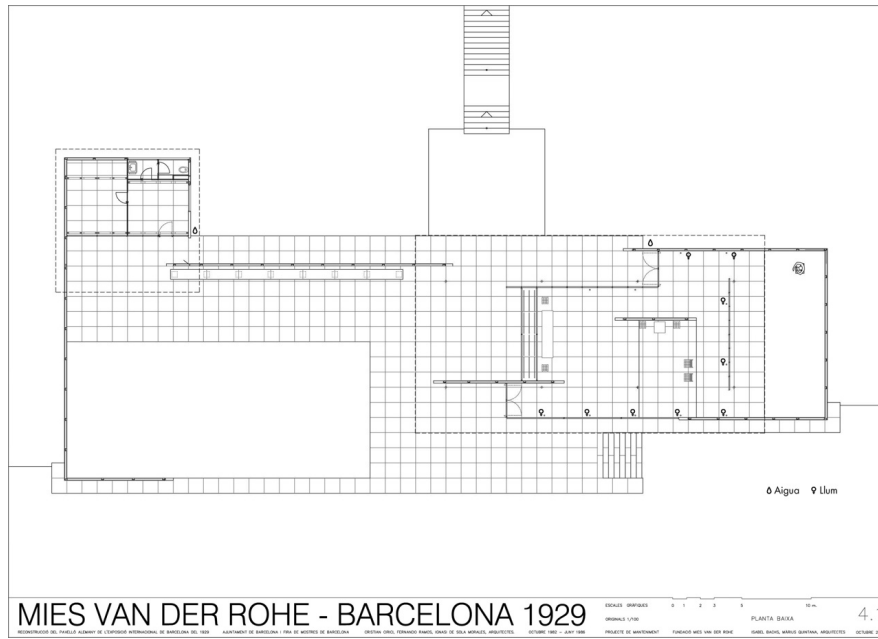

Fig 17 (top). Fig 18 (bottom).

### The Barcelona Pavilion to Standing Mies

Plan, Barcelona Pavillion, 1929, Ludwig Mies van der Rohe, Barcelona (top). From: Kelly, M. J., (30 Sep 2013). Mies van der Rohe Pavillion. Jason M. The plan was rotated -90 degrees and translated into a vertically standing section, extruded and mirrored, with the dashed roof line is interpreted as a massive suspended external wall panel and facade. The “Standing Mies” becomes a proposed iconic tower design, marking the subterranean station’s entrances.

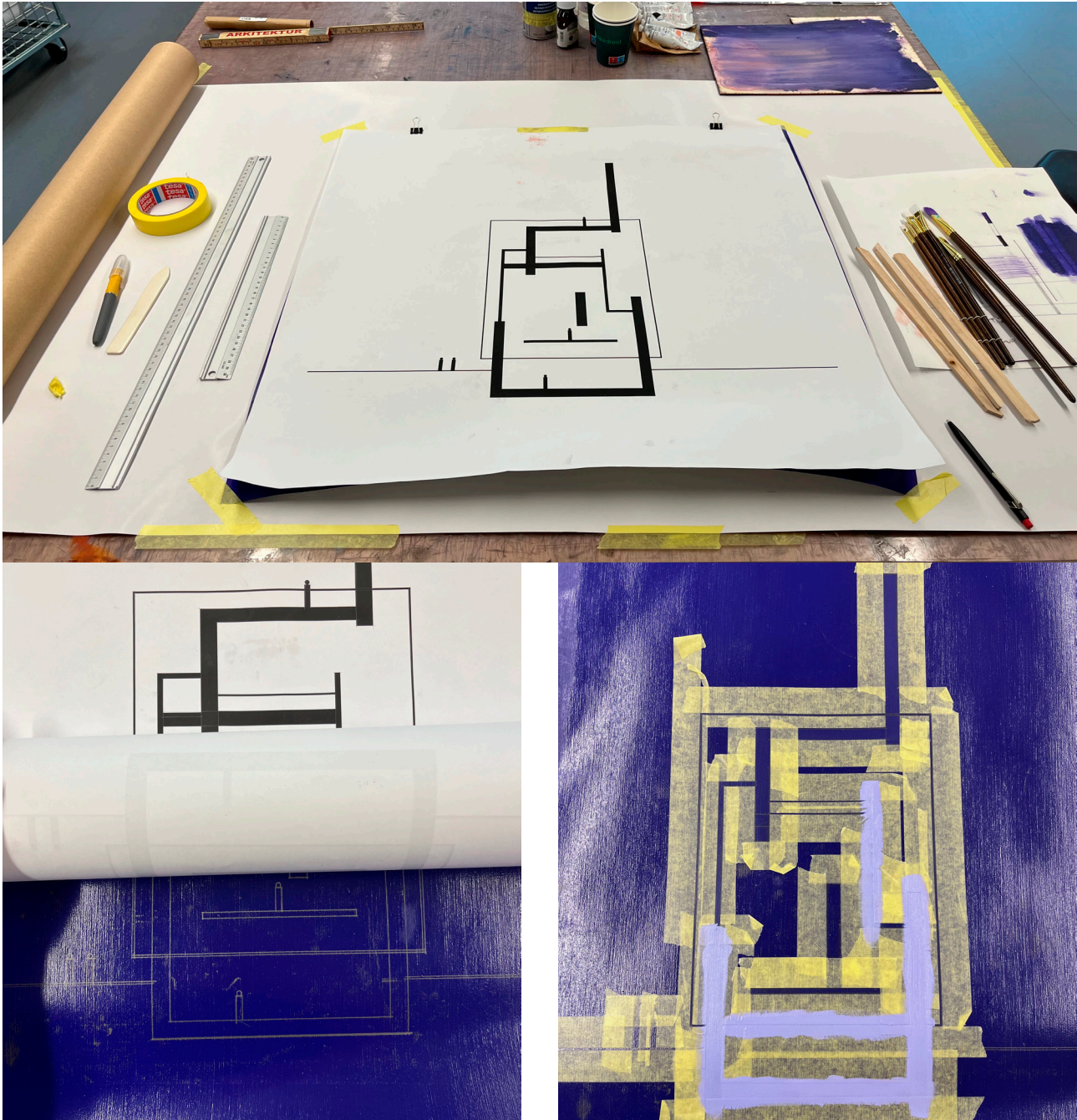

Fig 19

### The Standing Mies Artwork

The translated plan of the Barcelona Pavilion turned into a section drawing in scale 1:87, as well as a parti (image/digram/concept), and back into an icon and image, by means of turning it into a 60x60 cm oil painting.



*Extracts from subway investigation maps from 1934 and 1967 (Sveriges Radio, 2009).*

Fig 20

### Historic Metro Visions of Gothenburg

Excerpts of maps from the Gothenburg metro investigations of 1934 and 1967. In: Rudolphi, M. (2012). Allélinken: A study of the possibility and the potential effects of a tramway tunnel construction in Gothenburg city. [Master Thesis, 2012:11, Chalmers University of Technology].

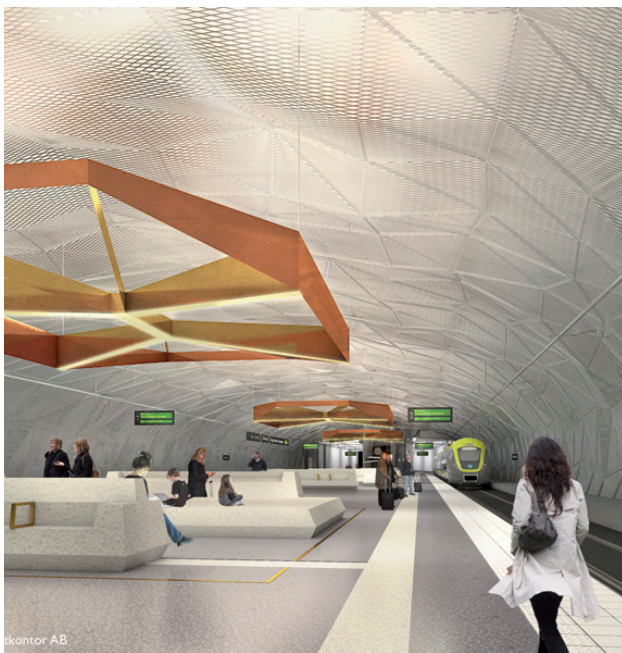

Fig 21-23

### Expected Infrastructural Architecture

Renderings of station spaces for “Västlänken”, designed by ABAKO Arkitektkontor AB. (Courtesy of ABAKO.)



## Rainbow snake

Konstverket Rainbow Snake består av ett 320 meter långt ormskelett vars kurviga linjer följer hela Haga station och slingrar sig upp genom jordlagren. Skelettets kotor binder samman stationens underjordiska rum med marknivån, där ormens huvud dyker upp vid entrén till cykelgaraget. Delar av den gigantiska kroppen kan skymtas utifrån, medan den största delen ligger under jord, med en stor bågformation i norra mellanplan och över tågstationens ena plattform.

### SYMBOLIK OCH ALLEGORI

Rainbow Snake blir den röda tråd som binder ihop stationens olika rum och följer reseansrens rörelsemönster på stationen. Ormen uppmanar oss också till reflektion över vår uppfattning av tid och rum. I många kulturer, myter och religioner över hela världen ses ormen som ett mäktigt och mångsidigt symboliskt djur och en allegori över transformation förändring. På så sätt blir skelettet även en metafor för tidens gång.

### KONSTNÄREN

Huang Yong Ping (f. 1954, Xiamen, Kina - d. 2019, Paris, Frankrike) har blivit känd för sina monumentala installationer som kombinerar storslagna gestaltningar med en mångbottnad konceptuell innebörd.

*"Ormen, närvarande i de flesta kulturer och religioner, är ett kraftfullt, mångsidigt och symboliskt djur. Den associeras ofta till föreställningar om förändring, mutation och rörelse."*  
Huang Yong Ping

Statens  
konstråd  
PUBLIC ART AGENCY SWEDEN

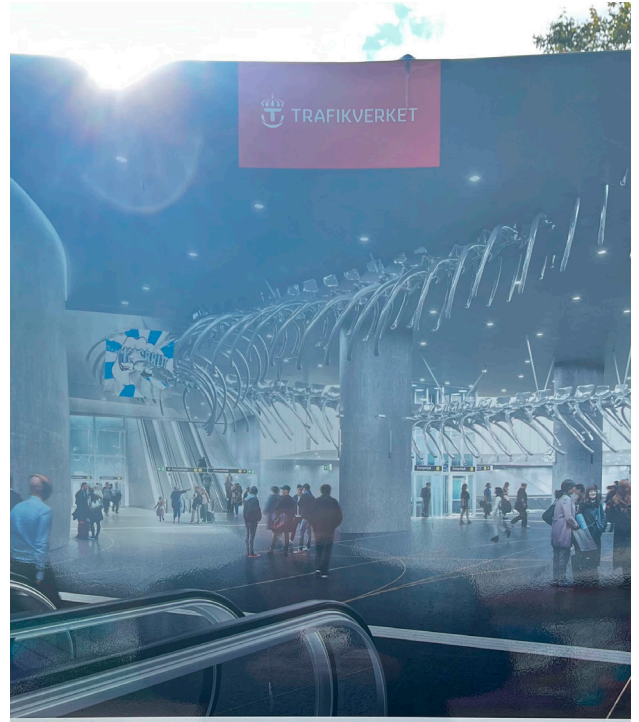

## Haga station

Haga station är placerad i hjärtat av Göteborg under parken Haga kyrkoplän och Hagakyrkan. Stationen bildar en viktig ny bytespunkt mellan tåg och stadstrafik framför allt västerut. Den underjordiska stationen ökar tillgängligheten till viktiga mål som Göteborgs universitet, city och utbyggnadsområden runt Järntorget och Södra Älvstranden. Stationen byggs med två 250 meter långa plattformar som ligger ca 20 meter under mark.

### HÖG ARKITEKTONISK NIVÅ

Om de underjordiska delar av stationen är generösa och storslagna är avtrycket ovan jord i en mindre skala, anpassade till den trängre och tätare stadsmiljön. I området finns historiska byggnader och miljöer som genomgående är av riksintresse. I utformningen av en stor underjordisk stationsbyggnad som Haga station ställs krav på att kombinera en hög arkitektonisk nivå med nödvändiga tekniska system för drift och säkerhet.

### KRONOTOPIA

Konstnärerna och konstarkitekterna som arbetar med projektet undersöker platsens tid, nutid och framtid. Det utforskande konceptet har fått namnet Kronotopia (av grekiskans *chronos* - tid och *topos* - plats). Trafikverket och Statens konstråd har genomfört internationella konsträvlingar för gestaltningen av Västlänkens stationerna och 2017 utsågs konstnären Huang Yong Ping till vinnare för den konstnärliga gestaltningen av Haga station - med förslaget Rainbow Snake.

Statens  
konstråd  
PUBLIC ART AGENCY SWEDEN



Fig 24 (left). Fig 25 (right).

## Embellished Station Spaces by Artwork

The artwork Rainbow Snake by Huang Yong Ping, supposed to embellish the station of Haga in "Västlänken".

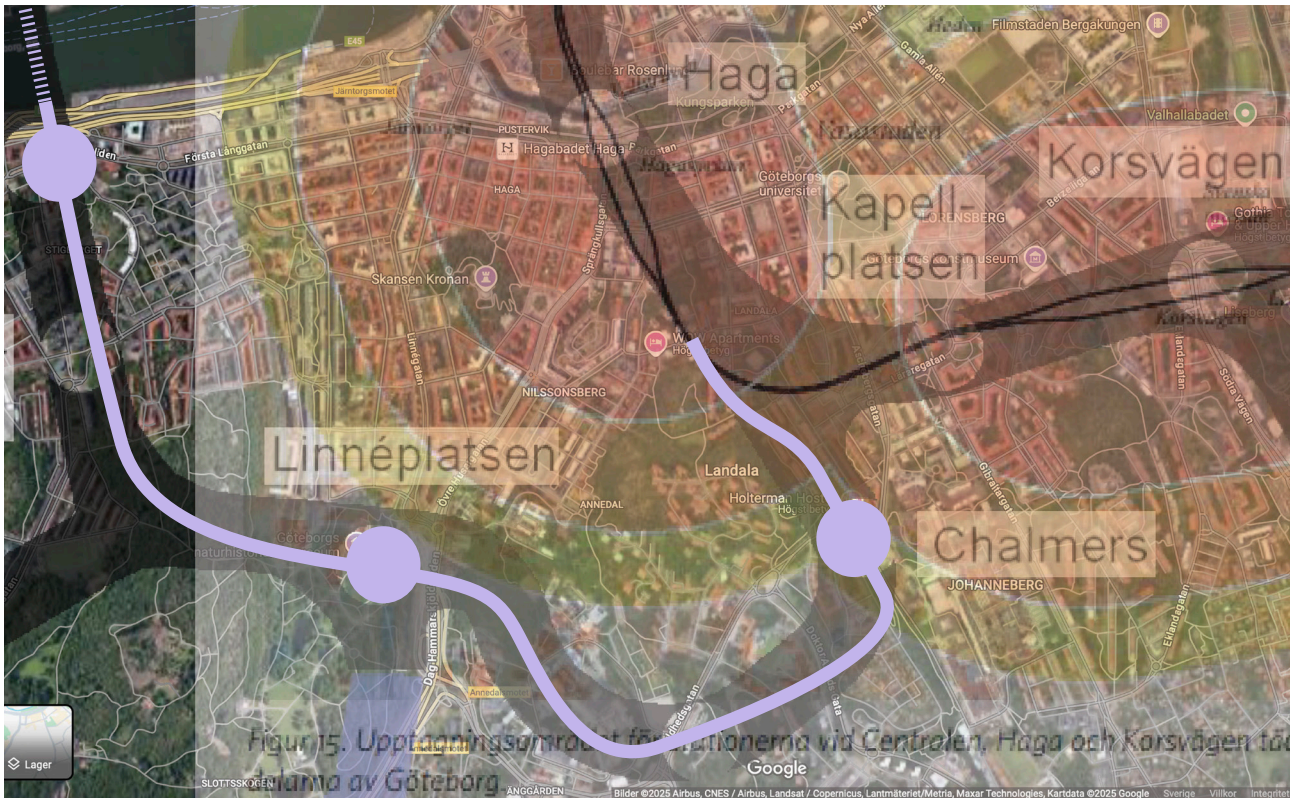

Figur 15. Uppfångningsområdet för stationerna vid Centralen, Haga och Korsvägen i de centrala delarna av Göteborg

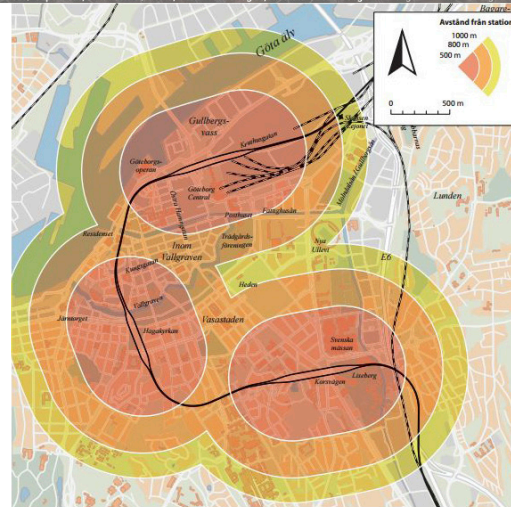
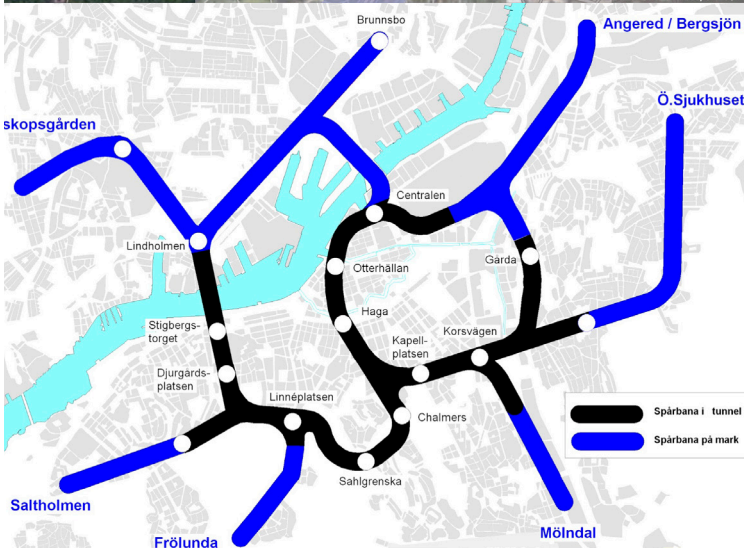

Figur 15. Uppfångningsområdet för stationerna vid Centralen, Haga och Korsvägen täcker in de centrala delarna av Göteborg.

Fig 26 (top). Fig 27 (bottom left). Fig 28 (bottom right).

### The Lavender Line

The speculative station locations of the Lavender Line (top): Overlay drawing of Stadsbanenätet (schematic map of the metro proposal of lobbyist group Tunnlebanan.nu) (low left), catchment area and line of Västlänken (Trafikverket, investigation) (low right), and Google Maps of central Gothenburg.



Fig 29  
**Lavender Line Site Map**

The speculative premetro line and connection to Västlänken. 1:5000 (600x600 mm).



Fig 30-31

### Lavender Line Site Plans

Three A1, scale 1:500, site plans of the three station locations along the Lavender Line. Pigment prints on paper of orthophoto from Lantmäteriet, primed with clear gesso and line painted in oil. From top: Stathmós Parthenon (Classic Antique) – *Stigbergstorget*; Stazione Tempietto (Renaissance) – *Linnéplatsen*; Seagram Station (Modernism) – *Chalmers*.

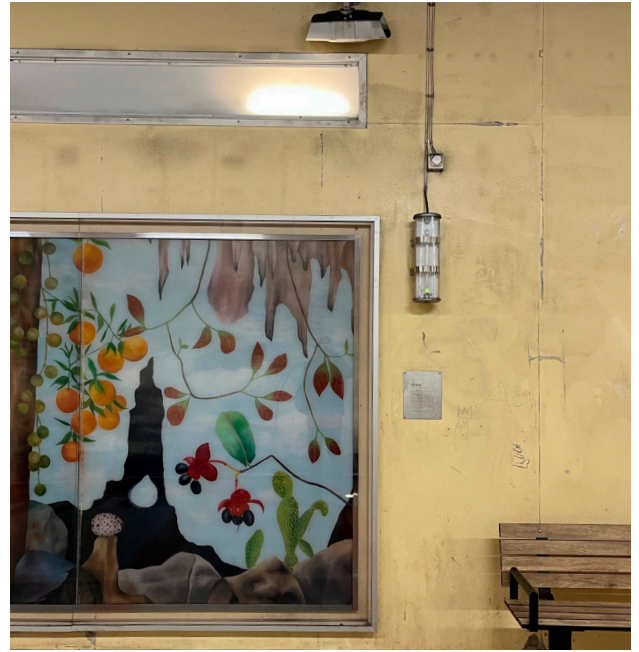

Fig 32-35

**Hammarkullen Subterranean Tram Station**

The only subterranean tram station in Gothenburg. A “tram cave”.



Fig 36 (top). Fig 37 (bottom).

## Stockholm Metro

Details of the glazed tiles in artistic patterns of T-Centralen metro station in Stockholm (above).

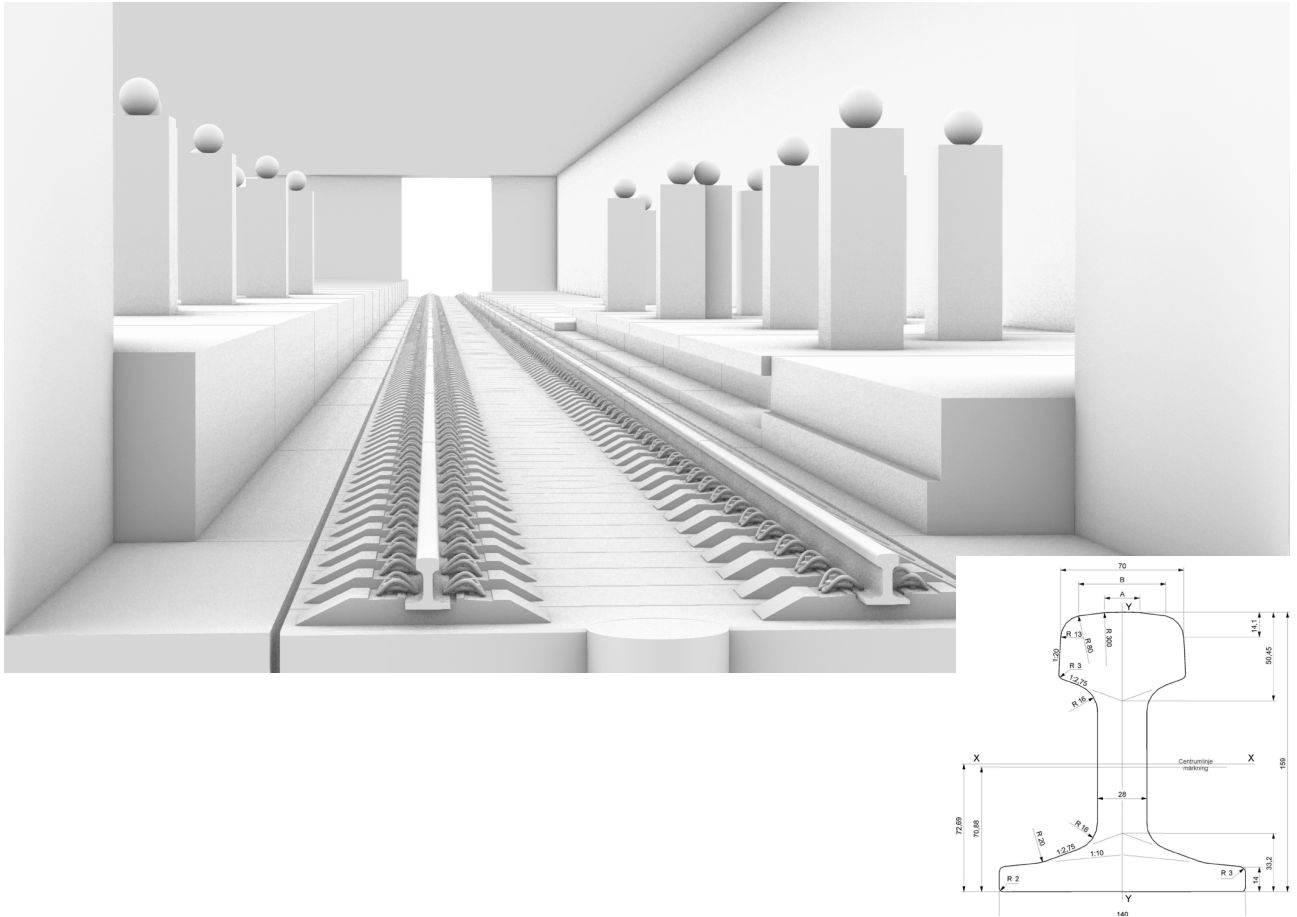
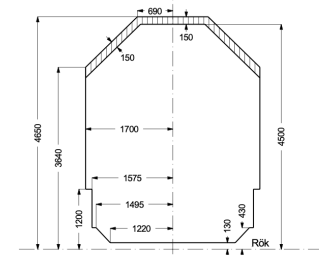

Fig 38 (main). Fig 39 (auxiliary).

### Concept Station and Platform Design

Platform for regular trains on the left, with the lower EU standard adopted as main standard in Sweden of 550 mm from RÖK (“rälsens överkant”; rail top); fitting the dynamic reference profile SEa, described by Trafikverket (2020). Two iterations of platform on the right fitting low floor trams with step height of 350 mm RÖK and a vehicle width of 2650 mm. Track gauge is standard 1435 mm. The closest is a fix platform adapted for clearance of the Swedish reference profile A, and is thus set 1430 mm from track center and 305 mm above RÖK. Leaving a height difference of 25 mm to vehicle floor, compared to today's curbs in Gothenburg leaving approx 140 mm. Though leaving a gap of 105 mm, exceeding the optimal platform gap of <75 mm, and today's curb gap of 45 mm. The second iteration is a platform which is height adaptable with mechanics or by means of floating platform decks lowered or heightened by the water line in a sub-basin in which the platform rests. This solves clearance for reference profile A, and set 350 mm above RÖK and 1370 mm from track center, maintains a gap of only 45 mm, and no step less entrance to tram. The slabtrack is designed with rail profile UIC54 and reference to German design and Japanese slabtrack standard for tunnels.

Figures



Statisk referensprofil A

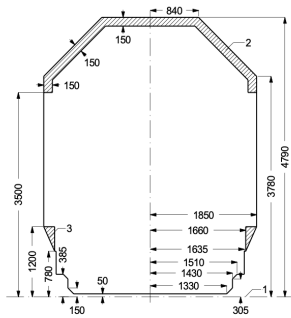

Dynamisk referensprofil SEa

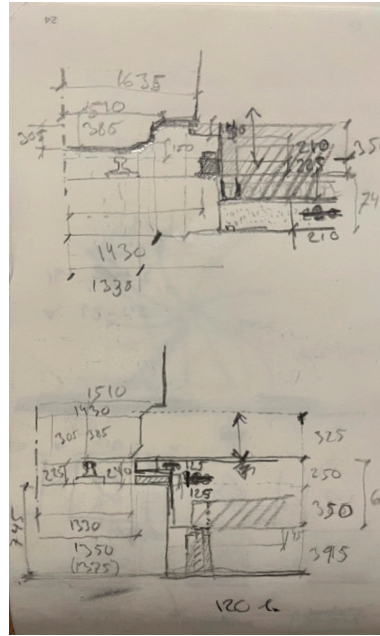

Fig 40-43

**Platform Heights and Gaps**

Static reference profile A and Dynamic reference profile SEa, (“lastprofiler”) described by Trafikverket (2020) (left). Sketch (upper right) and measurements of platform situations along the Gothenburg tram network today and the central station accommodating regular train services.

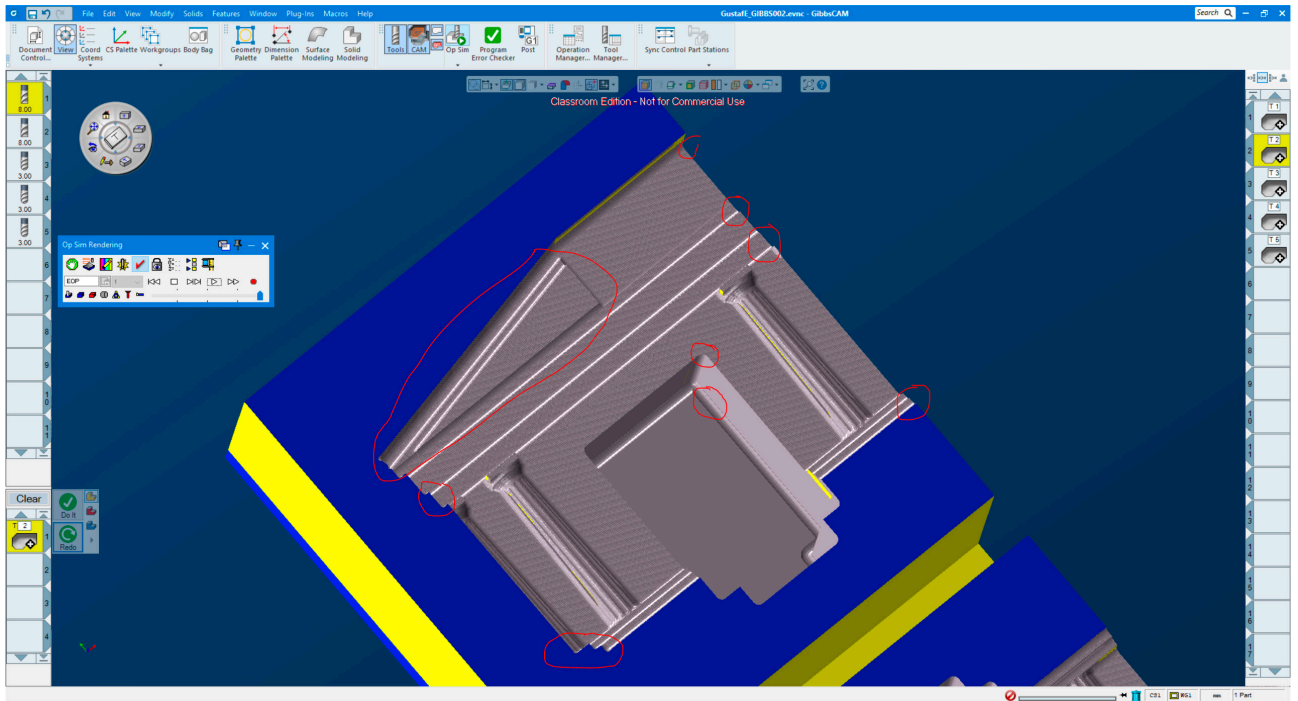

Fig 44

### Glitched Translation in Stage 3

By machine. When the positive casting mould is milled by a CNC machine, having only a certain tolerance and drilling tools set up. In this case fine details for instance will be lost from the original digital model, and sharp corners will get a soft edge.

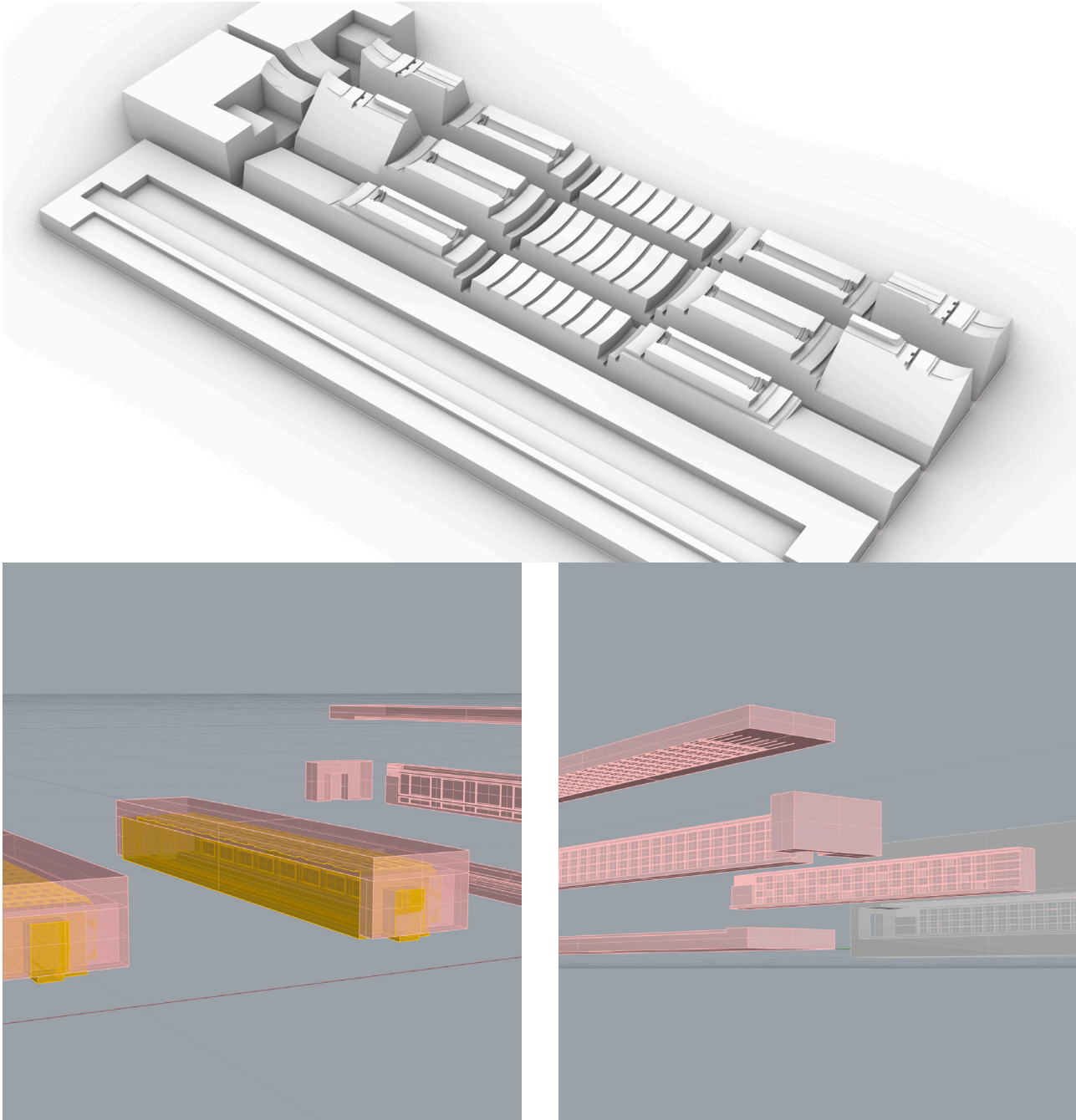

Fig 45

### From 3D Model to Casting Mould

The 3D modeled positive station spaces are cut into flat pieces that can be milled in XPS by a CNC machine. Most difficulty was the quarter round tube of the Tempietto station, showcasing a lot of details, edges and angles. To avoid an excess of negative angles when the pieces are laid flat, which hides areas and spaces that the CNC milling machine can't access and process, the space was after iterations cut up radially (above).



Fig 46-48

### Casting of Base Plate for Standing Mies

The frame and CNC milled foam was removed after the self-leveling concrete had hardened completely. The black flexible tube was left in place for the wiring of the electrics in the cardboard model.

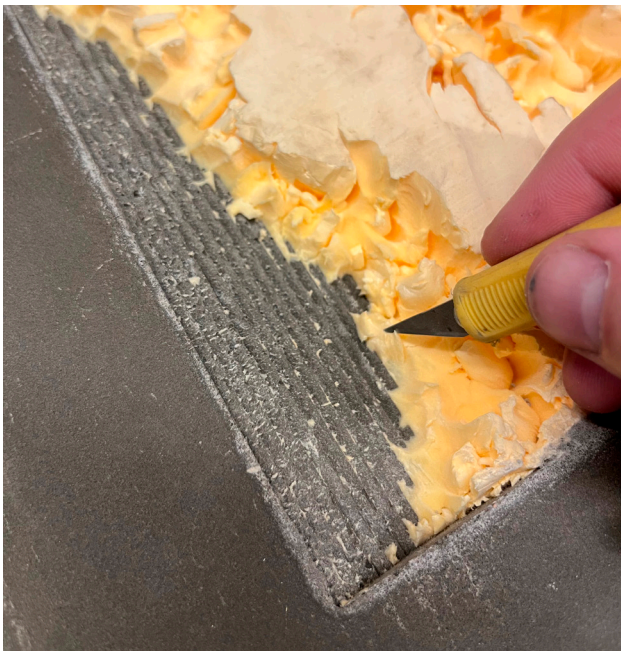
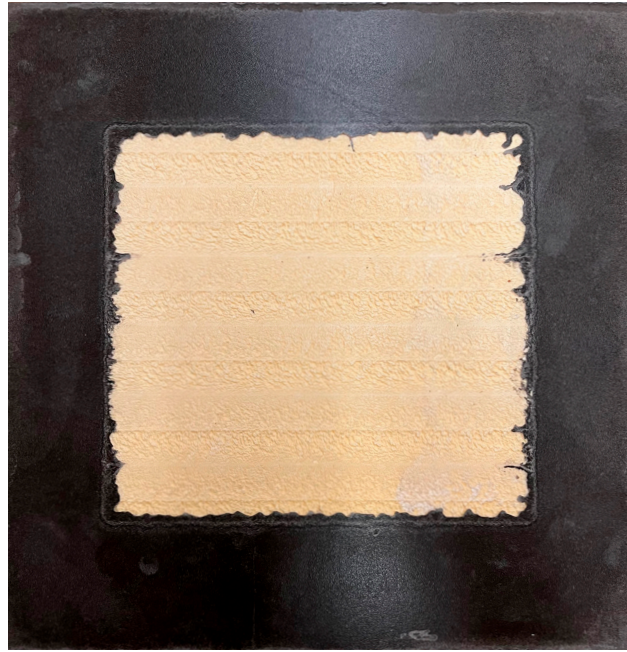

Fig 49-52

### Post Processing of Station Pit Cast

Removal of supporting frame (melamine covered chipboard) and XPS moulds, before sanding.

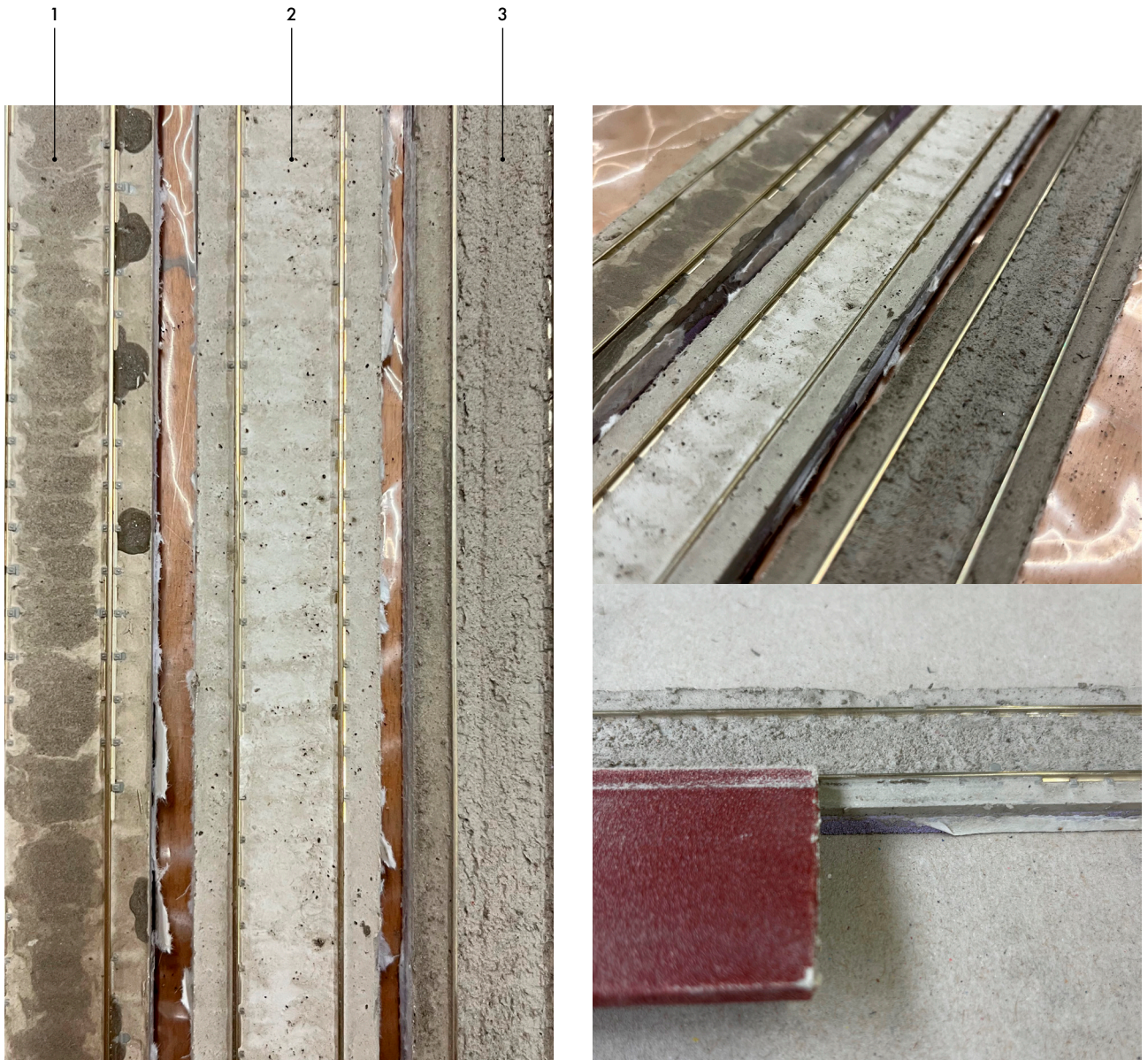

Fig 53-55

### Casting of Slab Tracks 1:87

Rocco Code 83 flex tracks was used, thus it is slightly too large. To accurately simulate the intended UIC54 standard, a rail corresponding to approximately Code 72 would have given the correct rail height. (The *Code* number indicates the rail dimensions in 1/1000 of an inch.) Color variation is due to experimentation with fluidity of the self-leveling concrete. Compound for track 1 was mixed with 17 % w/w water. Track 2: 20 % w/w water. Track 3: Same compound as 1, but poured when the mixture had sedimented somewhat and also begun to set a bit, resulting in coarser grains of sand in the poured mix, yielding a rougher surface. All tracks were sanded for a smoother finish.

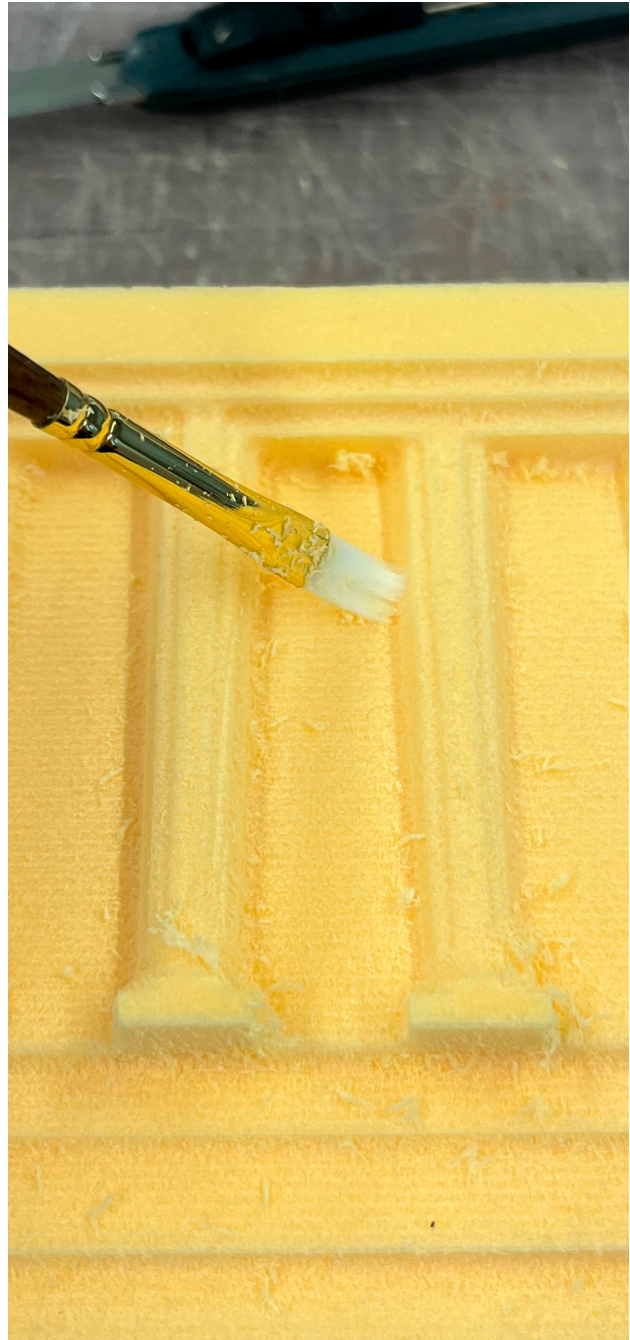
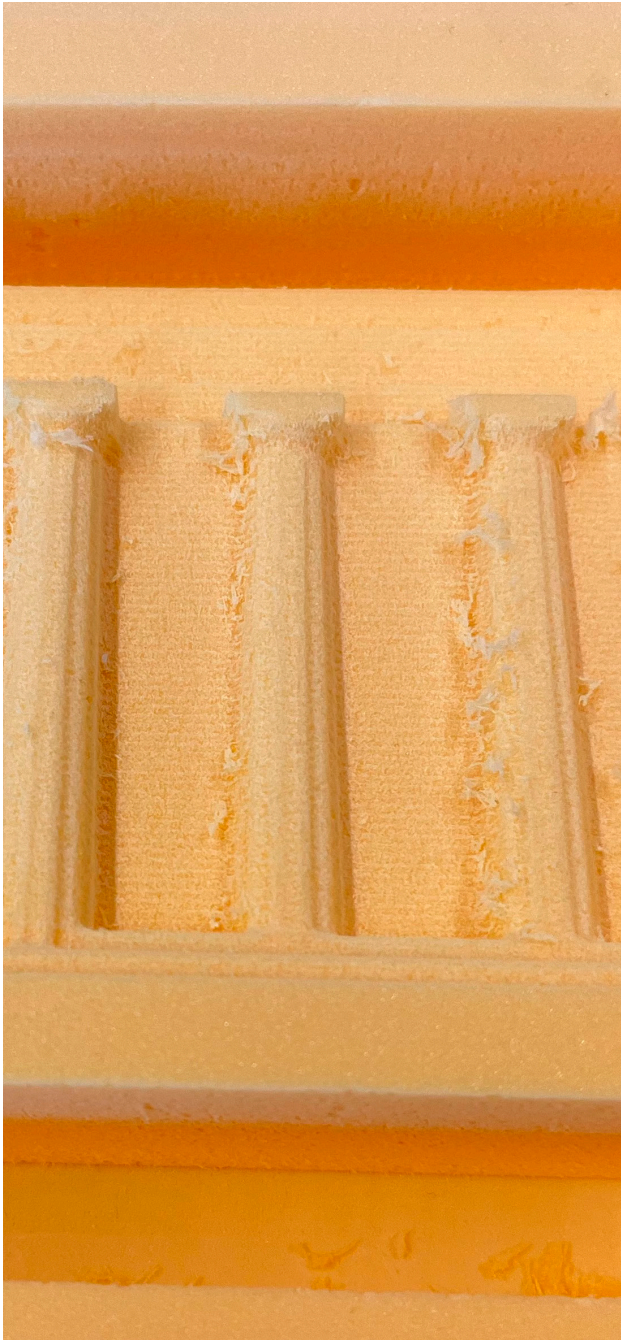

Fig 56-57

### Preparation of positive casting moulds

The CNC milled positive moulds in XPS are cleaned from any foam residues and polished with hard and softened brushes, before mounting.

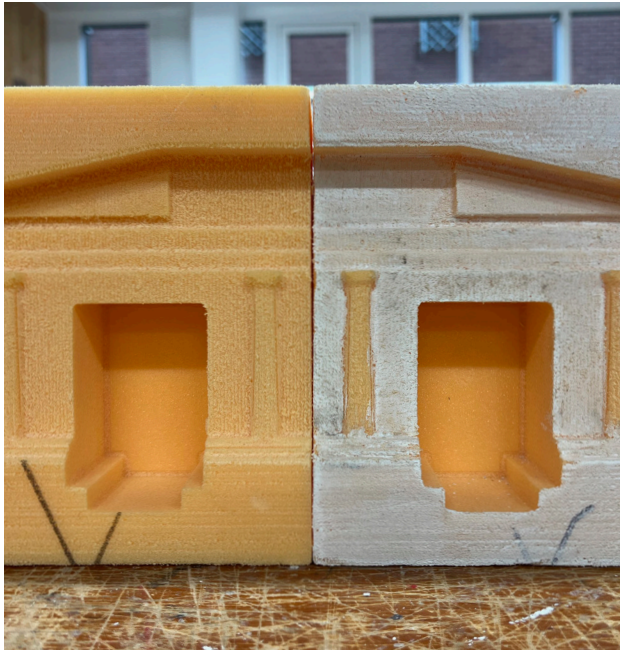

Fig 58-61

### Preparation of Positive Casting Moulds

Rougher surfaces and banding marks in the positive moulds left from CNC milling are covered with fine carpentry plaster, before sanded and glued together into the space. An infill block in XPS is placed in the mould, leaving 10-30 cm for the wax to be poured in.

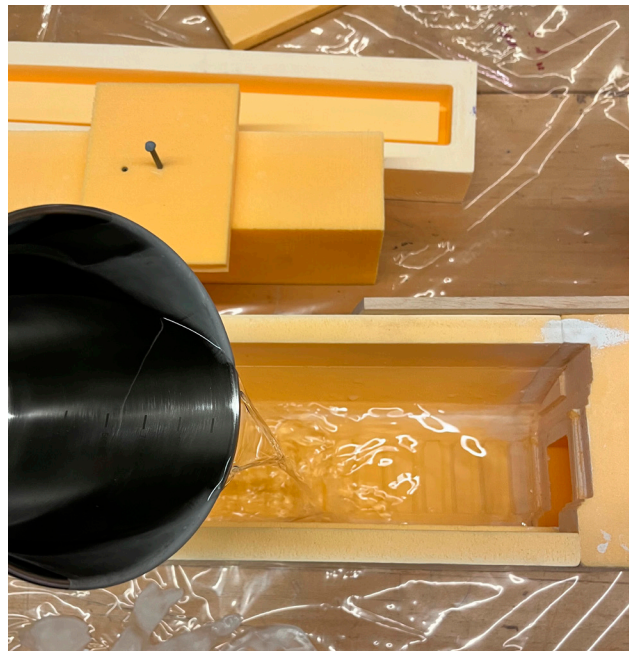

Fig 62-65

### Casting of Wax Negative

Paraffin wax are cut from 5 kg blocks and melted at a temperature of 70-80 °C. Then cooled to 57-63 °C before poured into the XPS mould. When the bottom part is filled the infill is put into place and the rest of the mould is topped up with wax. The resulting negative impression in wax, after further preparation, is used for the second stage casting back to the final positive in self leveling concrete.



Fig 66-67  
**Retouching of Wax Negative**

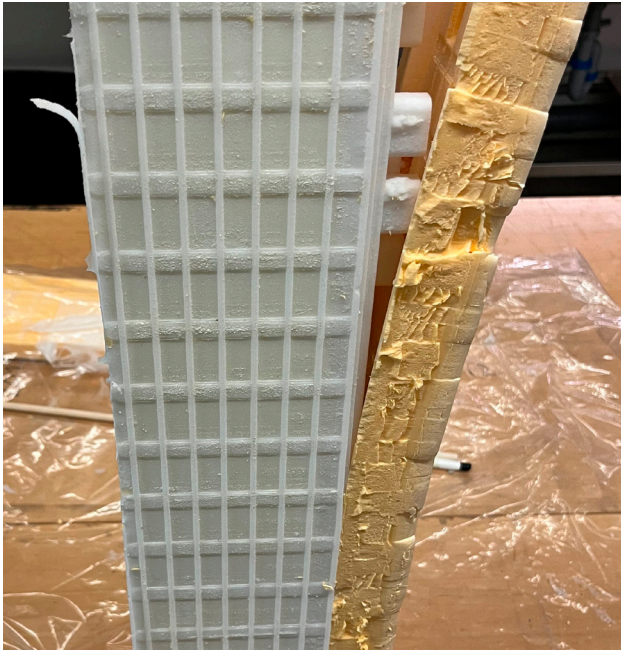

Fig 68-71

### Casting of Concrete Positive Autogram

The wax or silicone negative is placed in the bounding box and fitted with mounts and auxiliary tubing for wiring. The autogram is then casted in self leveling concrete and left to harden before removal of XPS infill and the negative shape wax or silicone.



Fig 72

### **Surreal Delirious Skyscraper Reemerge**

Unintentional image architecture and an amorphous intermediary interface. Stilleben and homage to Madelon Vriesendorp imagery in *Delirious New York* (Koolhaas, 1994[1978]). Unconscious paranoid critical method at work, expressing itself in the project.



Fig 73-75

### Losing Wax

The wax negative is exposed from the XPS infill, to be melted out and lost. Iconic column of the Parthenon station re-emerges. Finally the casted autogram [model] is exposed and set free.

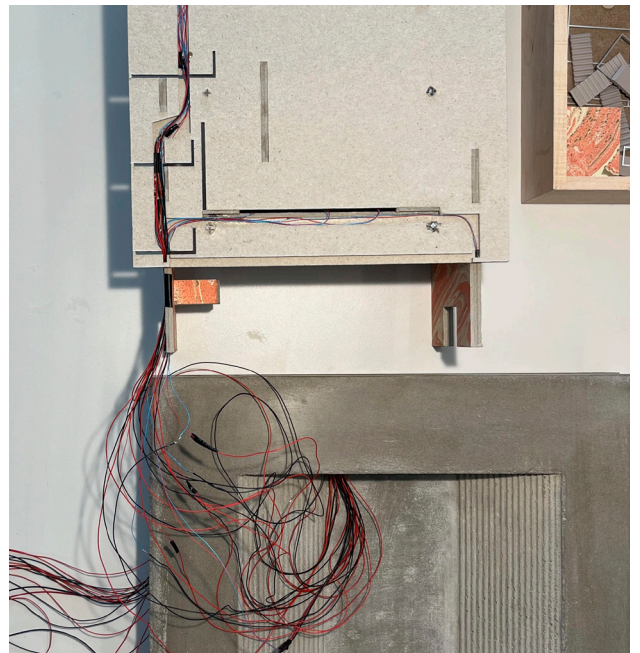
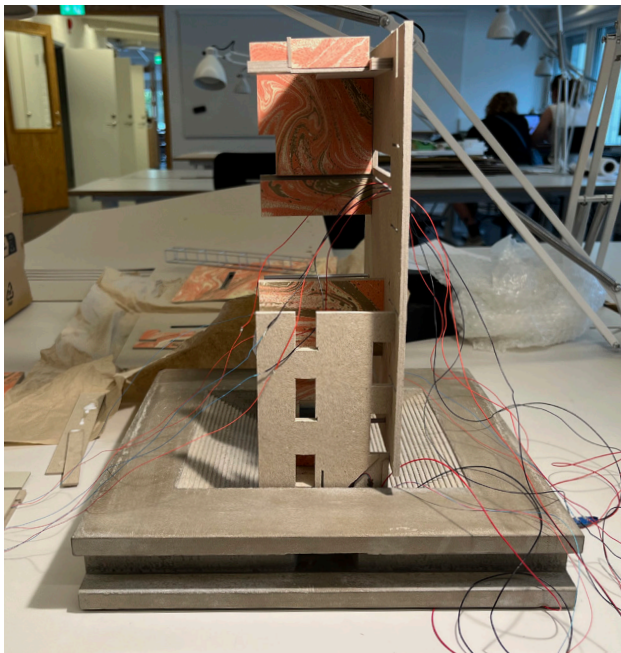
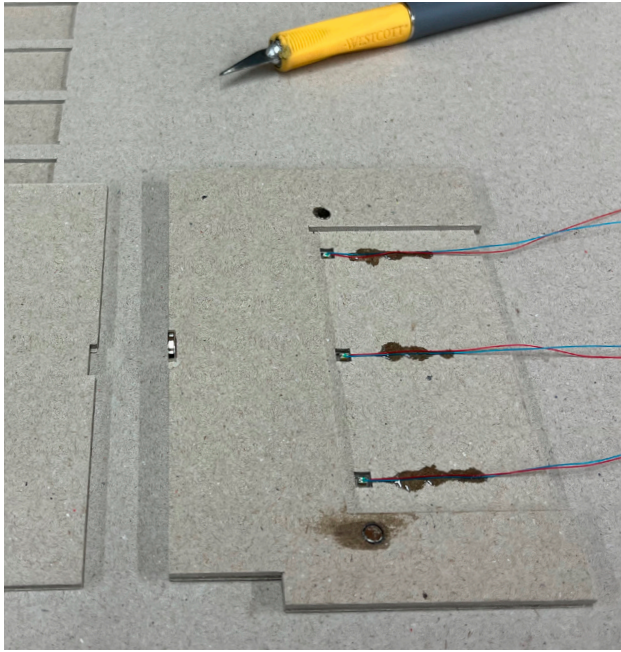

Fig 76-79

### Assembly of Standing Mies

Installation and wiring of SMD LED:s in Standing Mies and casted station pit.



## Recollections

Selected “Keys” from *The Script*.

The keys are imagery and diagrams with a function to visualise or abstract certain intellectual or textual drawings and ideas. The intention of the keys is for them to work as summaries/extracts/distillates/essences of the work or content.

In this appendix of *The Booklet*, they are re-presented without an elaborated context. Just as recollections, to show on their appearances, expressions, and content.

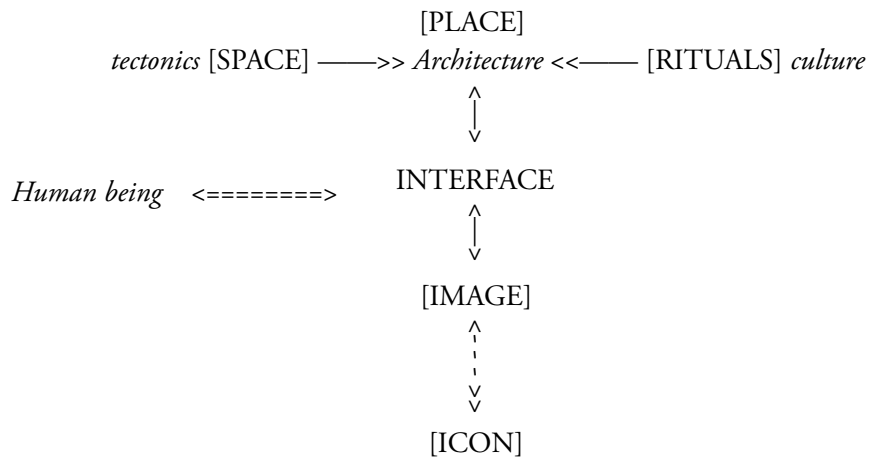

The iconic being potential radiation of the image.

### Key 1

#### *A Star is Born*

Digrammatic draft of how an icon as star is born, and the icon's relation to architecture and interface.

1st iteration

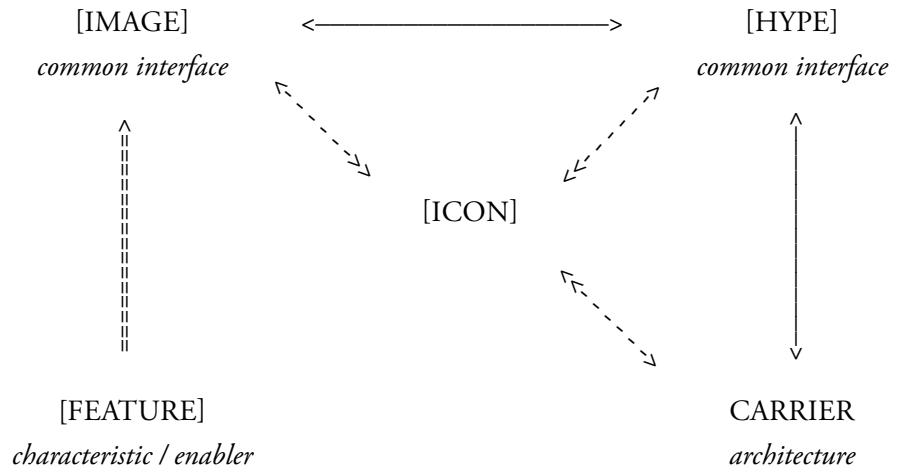

2nd iteration

Double line being input; Solid lines being media; Dashed line being mental constructs or conjectures.

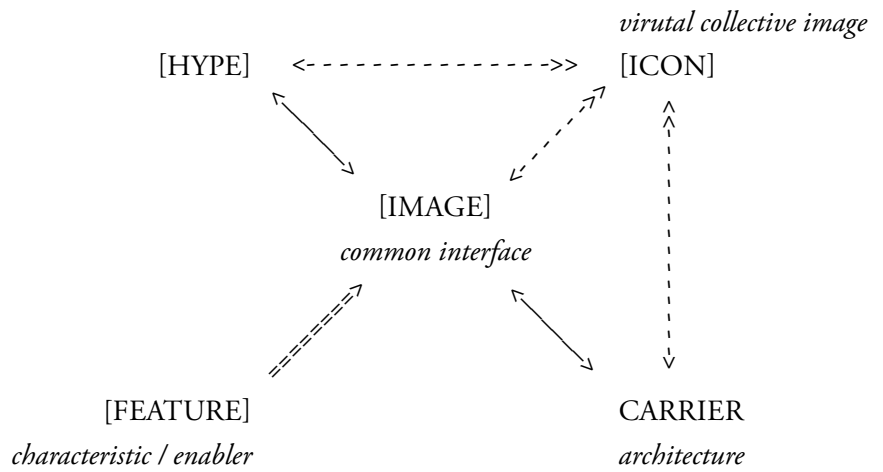

## Key 2

### *Image Carrier Hype*

Digrammatic draft of how an icon relates to the concepts of image, hype and carrier.

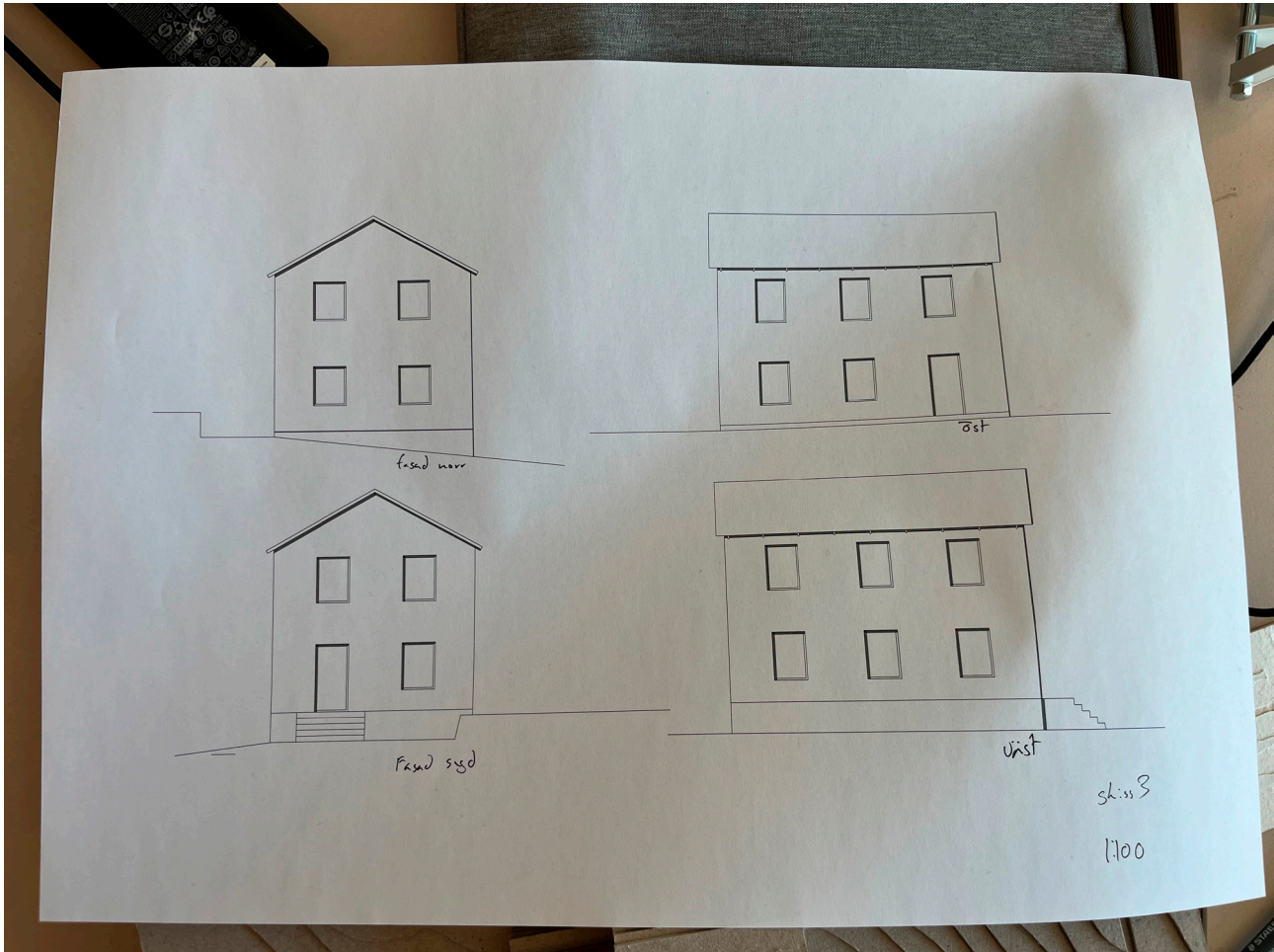

### Key 3

#### *Everyday Iconicity*

“A house looking like a *house*”. Early draft of a design, Master Thesis work by Vilhelm Anderson, 2025.

From “Iconicity Analysis” in *The Script*. Example of a potentially *open icon*.

A  
RECAP / ICONIC IRONIC PLACES



Pseudo-icon  
Connotative  
shadows  
Amplification / Cancellation

## Key 4

### *Connotative Shadows*

The latent iconicity of a city's individual parts are suppressed by its iconic entities covering the city. Individual parts become contextual content; either divested (deprived) of its iconicity; or with iconicity by inheritance as in an iconic bleed (or glow). We may talk about the major icons working by effect of iconic connotative shadows. Note how such a shadow may amplify or cancel out the iconic. Potentiality also creating pseudo-icons.

A  
RECAP / ICONIC IRONIC PLACES



Outsider /  
Insider  
Placelessness  
(Edward Relph)

## Key 5

### *Insider vs. Outsider*

Iconic architecture working by the embedded narrative's and motif's argument function (with regards to insiders/characters) and/or key function (with regards to outsiders/narratees).



## Key 6

### *TTL-seeing*

Exemplified by imagery. Through-The-Lens seeing. We see and evaluate photographically.



## Key 7

### *The Iconic Drawing*

Speculation of a third type of drawing. A subtype to the modern drawing and the contemporary drawing; elaboration from the concepts introduced by Dal Co (Decroos et al., 2020). See also **section 4.3, 6.8**.

Image courtesy: Campaign “Not Dressing Men”, Suistudio, 2017. (Print screen of campaign imagery.)

A  
RECAP / ICONIC IRONIC PLACES



Elli Hemberg, public sculpture, Skövde  
+ sculptural pile of junk



Art / Reality  
Juxtaposition & Superposition  
of Intention & Mishaps  
of Private & Public  
of Professional & Amateur  
a “icono-clash”  
(i.e. an ironic  
iconoclasm)  
In a world incused with:  
Redundancy  
Contextual overload  
Image consumption

## Key 8

### *Icono-Clash & Contextual Overload*

Exemplified by imagery. Key concepts.

Art meets Reality, the one intercepting the other. Juxtaposition and superposition, may be of intention or mishaps, by professional or amateur, in a world infused with redundancy, contextual overload, and image consumption, rendering an “icono-clash” (i.e. an ironic iconoclasm).

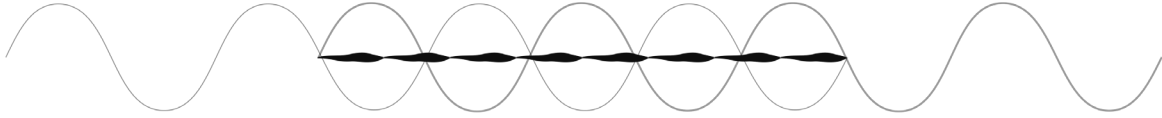

Photographic pseudo-documentary reality [one materiality]  
+ The networked mass age's image of the "true iconic view"  
Augmented by means of painting and drafting [an-other materiality]  
To achieve critical gaze by means of

SUPERPOSITION

AS WAVES  
CANCELLATION

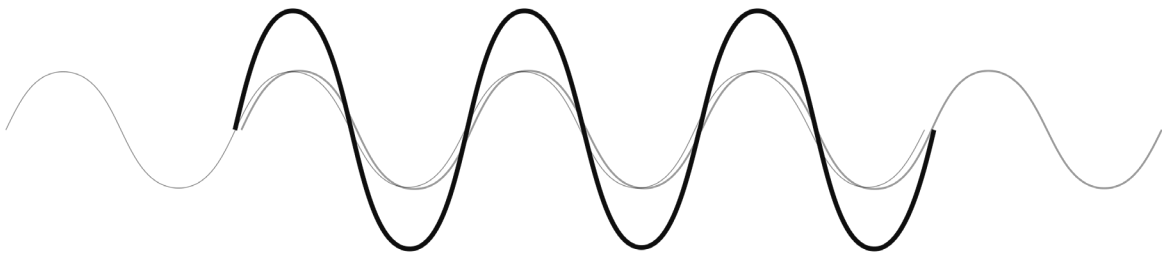

Photographic pseudo-documentary reality [one materiality]  
+ The networked mass age's image of the "true iconic view"  
Augmented by means of painting and drafting [an-other materiality]  
To achieve critical gaze by means of

SUPERPOSITION

AS WAVES  
AMPLIFICATION

## Key 9

*Superposition – Cancellation as wave (top)*

*Superposition – Amplification as wave (bottom)*

Diagrammatic effect in media and collective aesthetics and mind, when superposition generates cancellation of superimposed icons or the images of an icon. (Abstracted as waves).

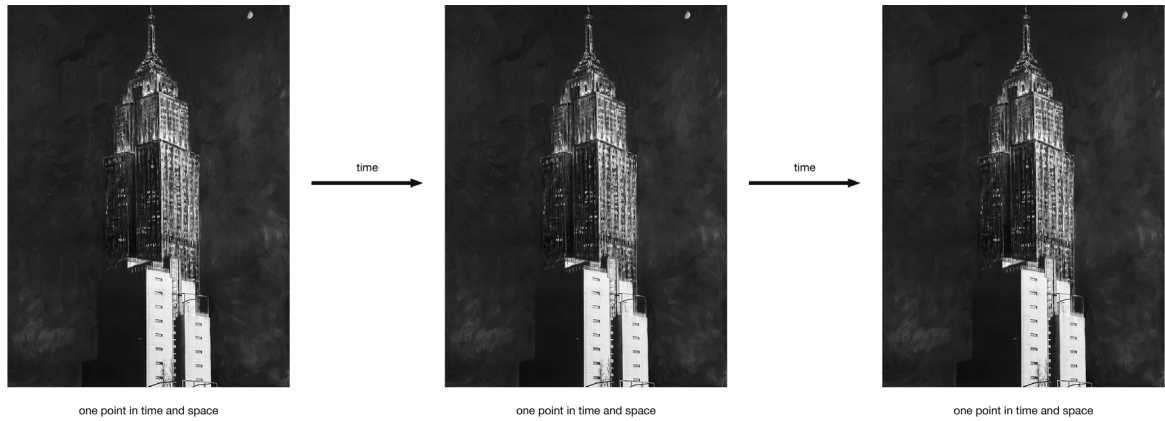

NO  
SUPERPOSITION

"NORMAL" LIFE / PERCEIVED IDEA OF "REALITY"

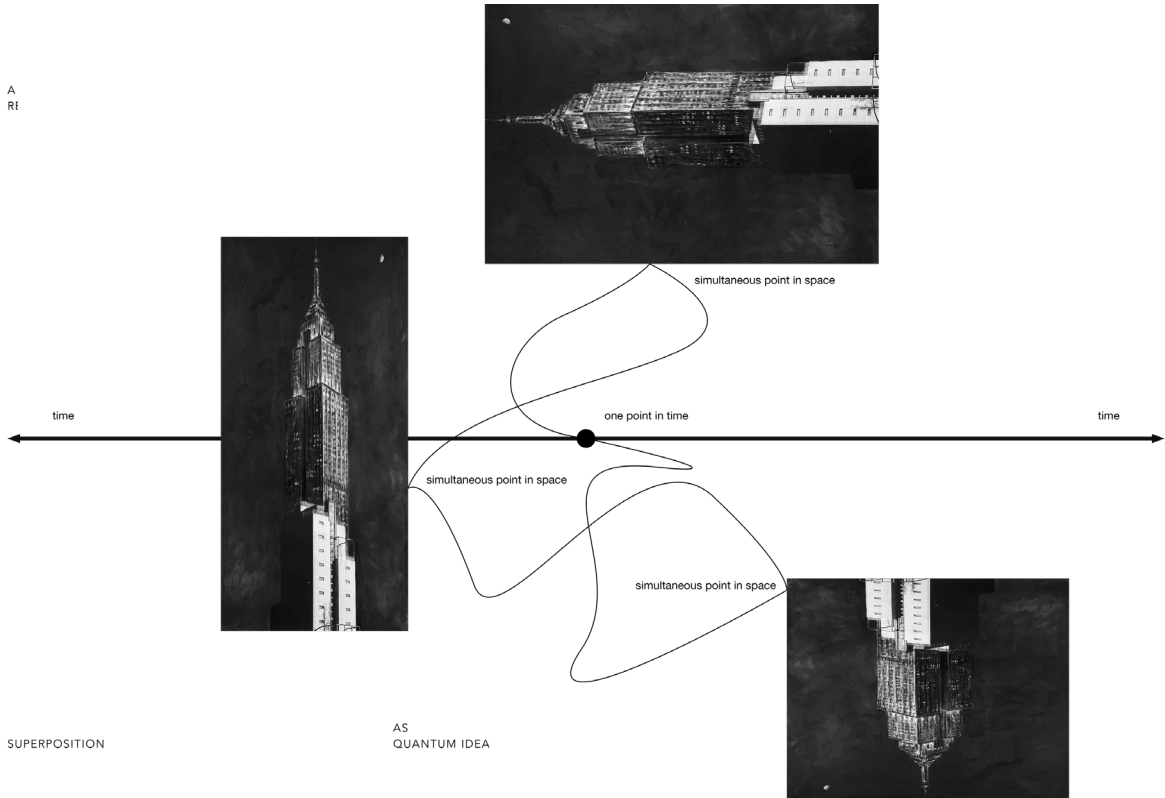

### Key 10

*Linear and conventional understanding of an icon through time (top).*

Diagrammatic abstraction. The Icon appears as one, definitive and absolute through linear and sequential conception of time.

*Quantum superpositioned understanding of an icon through time (bottom).*

Diagrammatic abstraction. The Icon appears when observed or interacted with, in between it is a mere function of probability. Non conform, nor absolute, nor existing in one single place at any given moment.



And a man can't see himself  
Without a reflection  
The sun doesn't shine on itself  
And so the icon is iconic  
To us, not to itself  
Through reflection  
And exerted effect

That was when i realised  
Why no one really spoke about it anymore  
Why no one seemed to want to  
Aspire to it anymore  
The iconic architecture  
I and it had been caught in limbo  
In between two realms  
To the few able to achieve the icon  
It has been implicitly understood  
To the masses though a thing of devotion  
Either it's already understood  
Or still a devotional infinite mystery  
To neither of them something to explain  
But to live with or in  
I've been trying to make it to the few  
While I've been praising it blindly  
In my limbo state of mind

ICONIC ARCHITECTURE  
by Gustaf Elias

Idea, concept, content, design and layout:  
Gustaf Elias Studios · gustafelias.com

Scents, *eau de parfum*, designed in collaboration with, and developed  
exclusively for the *Iconic Architecture* project by:  
Kerstin Strömberg · Art in Experience · artinexperience.com

Ambient soundtracks designed and developed in collaboration with:  
Herou · Tuva Herou · @heroumusic

Voice messages on the phone, a call from another point in time and a space,  
recorded by:  
Julia Lundberg · Script and Mix by Gustaf Elias

Curatorial text:  
Viveka Kjellmer · Associate Professor of Art History and Visual Studies,  
Department of Cultural Sciences, University of Gothenburg.

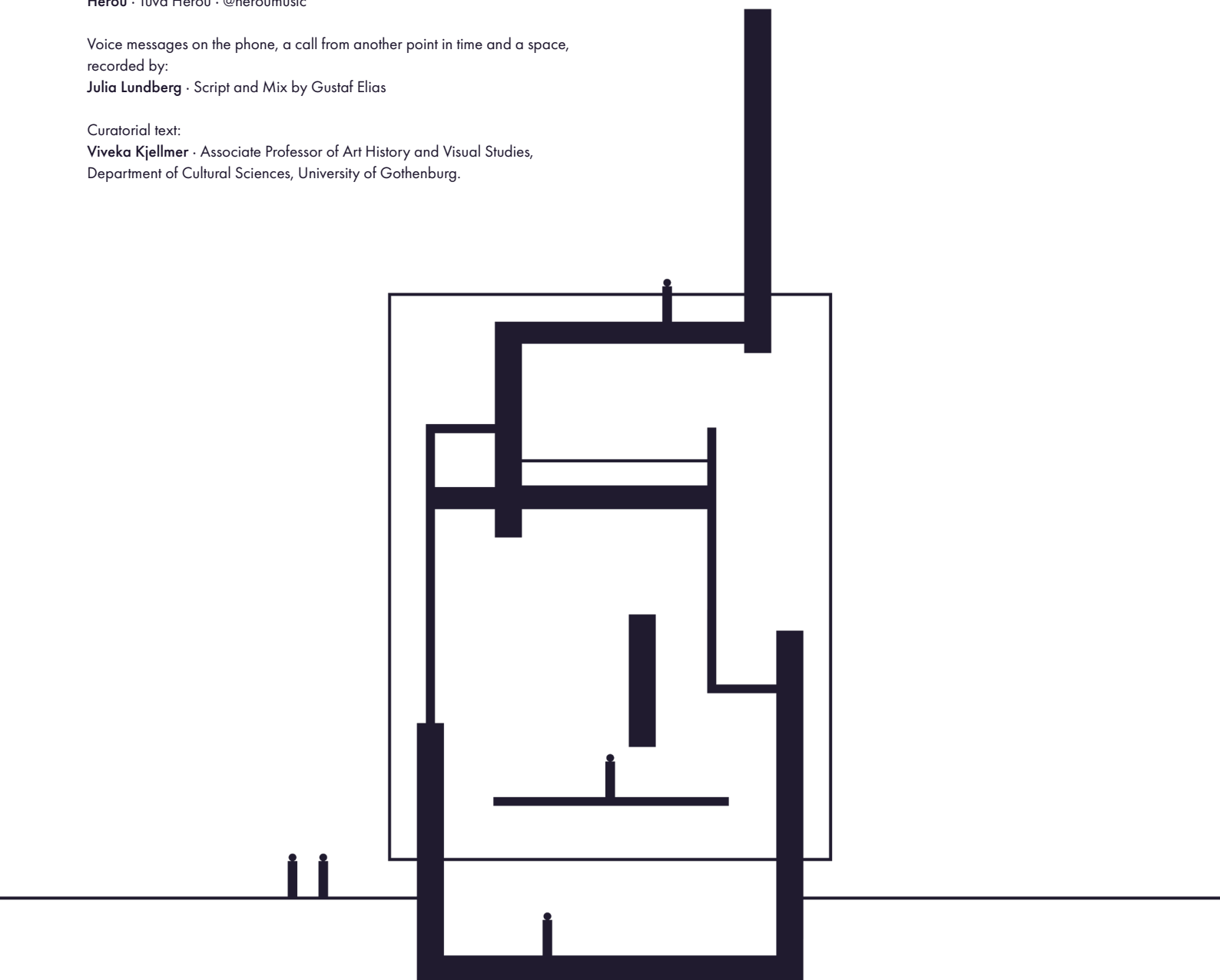

1.2 edition 2025. 250609-2201.

© 2025 Gustaf Elias Studios, artists, authors, contributors.

All rights reserved.