

THIS IS NOT

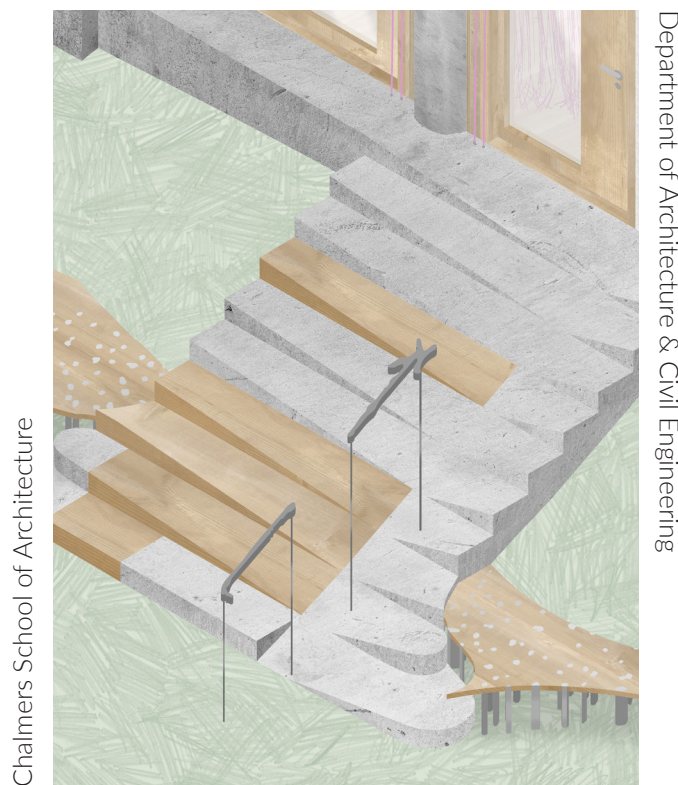

Chalmers School of Architecture

Department of Architecture & Civil Engineering

using the (mis)interpretation of drawings as a method
to design non-conventional architecture

2024

by **JULIA FORSBERG**
examiner **DANIEL NORELL**
supervisor **KARIN HEDLUND**

A BUILDING

Abstract

A drawing is a representation of an object; it is an abstracted version of the object, stripping it from three dimensions to two. This act inevitably causes a loss of information, gaps which are filled with the reader's subjective interpretation.

Evans (1986) describes architecture as the translation from drawing to building. The drawing is the architect's final output, and the information it conveys is loaded with values. Weisman (2000) states that "architecture [...] is a record of deeds of those who have the power to build" (p. 86). Although drawing is largely seen as a neutral tool for representing architecture, this thesis argues that by putting these theories together, we could understand the translation from drawing to building not as something neutral but rather as an act based on societal values.

To orient ourselves in drawings we use conventions. Ahmed (2006) writes about the relationship between queerness and disorientation, and states that to queer space is to disturb the order of things. Through a series of explorations, this thesis develops a method of design based on the (mis)interpretation of drawings and their conventions, disturbing their order – enabling a reading of drawing which is disorienting and queer. An

influential part of the method is also the translation of an analog drawing into vectors, done through a mixture of manual and automated tracing.

The method is applied to a design project based on the (mis)interpretation of the hand drawn entrance floor plan of Slottsviken, Mölndal. Slottsviken is a costly villa built originally in 1898, today used as a private conference venue with its grounds closed off from the public with a black iron gate – the villa only to be seen from opposite the lake next to it. The design project distortedly mirrors the villa from across the lake, but answers to the private extravaganza with something public and celebratory – a community centre.

The intention of the thesis is not to critique the subjectiveness of drawing, but to urge the reader to be aware and intentional with their interpretations, and to raise a conversation about future uses of drawing, highlighting that there are more stories to be told. The thesis celebrates drawing through creative use of it and argues that non-conventional but functional and intriguing design can be discovered through the method of (mis)interpretation.

Title.....This Is Not a Building:
Using the (Mis)Interpretation of Drawings as a Method to Design Non-Conventional Architecture
Author.....Julia Forsberg
Year.....2024
Institution.....Chalmers School of Architecture, Department of Architecture & Civil Engineering
Program.....Architecture and Urban Design
Examiner.....Daniel Norell
Supervisor.....Karin Hedlund

Keywords.....architecture, drawing, interpretation, representation, non-conventional, queer

Table of Contents

INTRODUCTION	4	BIBLIOGRAPHY	78
Foreword.....	6	FIGURES	79
Research Questions.....	7		
Intentions.....	7		
Terminology.....	7		
Delimitations.....	7		
Drawings and Subjectivity.....	8		
Drawings and Orientations.....	14		
METHOD	16		
Method Diagram.....	18		
Drawing: Conventions and Interpretations.....	20		
Explorations.....	24		
SITE	30		
The Labbera Peninsula.....	32		
PROCESS	38		
Vectorising the Drawing.....	40		
Open Curves.....	46		
The Automatically Traced.....	52		
PROPOSED INTERPRETATION	56		
The Exterior.....	58		
The Interior.....	62		
DISCUSSION and REFLECTIONS	74		
STUDENT BACKGROUND	76		
ACKNOWLEDGEMENTS	77		



Staring at the dirt I have scraped 'clean' I see a chaotic jumble of colours and a scatter of stones. Reuben slaps a hand on my shoulder.

'You've found it' he announces, 'It's the Norman Tower.'

I can just barely make out a patch with more green-grey mottles than everywhere else. It makes a squarish shape disappearing under the walls of the abbey. Perhaps there are more stones embedded in the shadow, but there are stones everywhere else as well. I look doubtfully at Reuben.

'I can't see an edge.' (I want to make sure that what I see is the same as what he sees).

'Yeah you can' he offers 'It's here'. He draws a line on the ground with his trowel, excluding some of the stones that I might have included.

'But wouldn't you say here?' I draw a rival line just outside his including the stones, which might be tipping down into something.

Noticing us having a 'conflab' Johnny takes a break from shovelling and ambles over. A short distance away he stops, considers the ground. He advances again and begins frantically scraping the soil a metre or so to my right. 'I'd take it back to here myself.'

Reuben scrutinises, beginning to scrape, 'I'm not convinced...'

- Wickstead (2008, p. 2) in *Drawing: The Purpose*

Part One

Introduction

Foreword

The theme of this thesis is drawings and their subjectivity. What motivated me to choose this theme was a feeling of frustration, since in my experience drawings are generally perceived to be a neutral tool for designing and representing architecture, which I disagree with. Initially, working with the intentional misinterpretation of drawings was a way for me to make a point and add a comment to the discussion of drawings.

But during the process I realised that there is one more reason to work with this method – to create alternative stories. In that sense, **the thesis celebrates drawing through creative use of it.**

I hope readers of this thesis will reflect on their positions within the discourse and feel inspired to challenge themselves through practicing intentional (mis)interpretation.

Research Questions

How can the (mis)interpretation of existing architectural drawings be used to develop an alternative method of design?

and

How can a method of alternative interpretation be used in order to design a community centre using the hand drawn architectural plan of a villa, namely Slottsviken?

and

How can representation be used to communicate a non-conventional interpretation of a drawing, and the result of such an interpretation?

Intentions

Ehrnberger (2017) states that unawareness of your own position and prerogative of interpretation can lead to consequences that go against the norm critical ambition, but that design becomes an effective tool to make visible and communicate this (p. 202).

With this thesis, I intend to be intentional with and aware of my subjectiveness. By having a fundamental understanding of drawings as subjective matters, I become empowered to use said drawings as operative tools, creating alternative stories using my readings of them. Using research through design, I want to explore and test the limit of these readings. The intention is to, at the end of this thesis, have achieved a greater understanding of the creative potentials contained in already made drawings – highlighting that there are more stories to be told. It is not an attempt to design the most beautiful or the most efficient building, but rather something to be seen as a discussion piece.

Lastly, I intend to not only be aware of my subjectiveness, but also be transparent with it. To throughout the thesis, in text and in drawing, remind the reader of the existence of an author.

Terminology

Interpret, Read, Translate

Goodman (1968) writes: “reception and interpretation are not separable operations; they are thoroughly interdependent” (p. 8). Based on this notion, the terms *interpret*, *read*, and *translate* are used semi-synonymously throughout the thesis. When reading a drawing, you inherently make an interpretation of it, and when translating a drawing e.g. from 2D to 3D, you inherently make an interpretation of it.

Delimitations

Plan Drawings

I believe the theories and methods discussed in this thesis could be applicable to different types of drawings – perhaps even different mediums? – but for the design exercises of this project I have chosen to focus specifically on the interpretation of plan drawings due to my personal interest in them.

Artificial Intelligence

In discussions about this thesis with student colleagues and tutors, the question of AI has come up quite a few times. How would AI describe a drawing in words? How would AI draw e.g. a plan given a description? Would we be able to reach objectivity using AI? (Off the top: no). At the time of writing this, AI is developing fast and it is raising wide-spread concerns regarding the future of architects. It is not an irrelevant issue, to work with how AI interprets existing drawings. However, I am personally more interested in exploring the human interpretation. Additionally, having no previous experience, I find learning to manoeuvre AI too big of a task to fit in the time frame of this thesis. Therefore, I will not be working with AI.

Accessibility

Slottsviken is not a building adjusted for accessibility, which is reflected both in its architectural plans and my interpretation thereof. That is not to say it would not have been possible to make an interpretation in which the building would become accessible for e.g. wheelchair users, but that has not been the focus of this project.

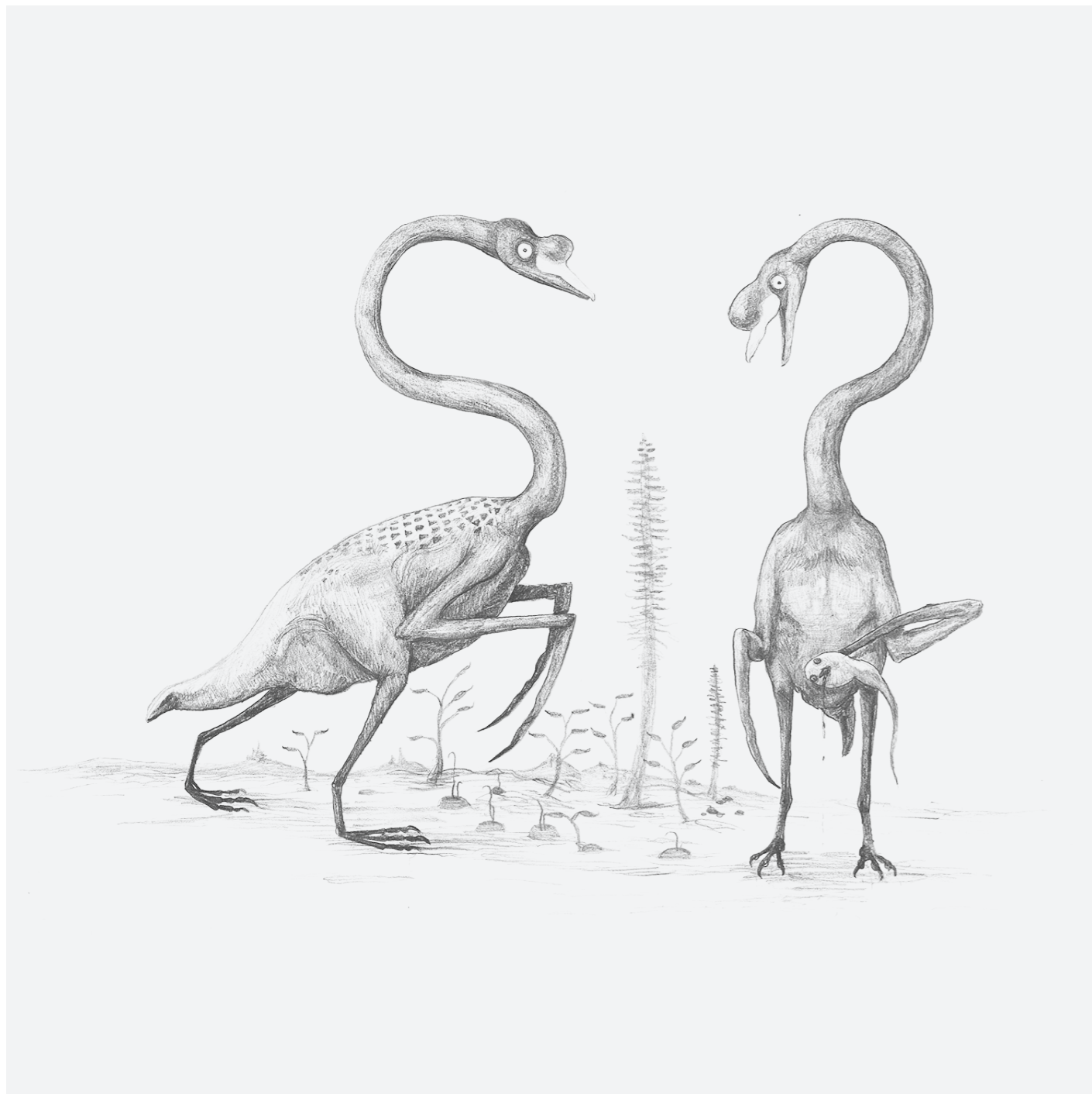

Fig. 1 / Scythe-armed swans, as imagined by clueless palaeontologists millions of years in the future. (Kosemen, 2012). Courtesy of the artist.

Drawings and Subjectivity

A Palaeontological Analogy

I first became interested in the topic of drawings as a subjective matter in the spring of 2023. However, what brought me into the conversation was not an architectural reference, but rather an analogy I found in the palaeontological discussions. In the book *All Yesterdays: Unique and Speculative Views of Dinosaurs and Other Prehistoric Animals*, Conway et al. (2012) inaccurately

reconstruct non-extinct animals in order to highlight the margin of error present in modern day dinosaur reconstructions. They reconstruct the animals based on their skeleton, but also on their preconceived notions about what an animal looks like – basically in the same way that palaeoartists typically reconstruct dinosaurs. Essentially what this tells us is that we have

a probable misconception of what dinosaurs looked like in reality.

Connecting the story of palaeontological reconstructions back to architecture, the way I make sense of it is by translating “bones” into “drawings” and raising the question of what, as architects, our drawings can convey. Our drawings are packed with symbols which we have agreed carry a certain meaning, but they might not carry the same meaning tomorrow, or to someone with a different habitus. We believe drawings follow a certain set of rules, putting a lot of faith into what information can be held by simple lines.

//

A Norm Critical Introduction

In the essay *Social Theory of Space: Architecture and the Production of Self, Culture and Society*, Archer (2005) describes a series of theories concerning how society and architecture mutually influence each other. For example, he mentions Bourdieu’s “habitus” – a word representing all attributes the individual possesses (gender, ethnicity, class affiliation, etc.). With the help of habitus, you can describe the relation between people and space. He proceeds to tell us about the feminist theory that space is not definite. Rather, it is shaped by its perceiver. A person’s histories and traits, or *habitus*, affects space in aspects such as how it can be utilised.

Weisman (2000) argues in a similar fashion that architecture is shaped by our societal values. Architecture is the embodiment of economics and politics and we need to understand it as such. Weisman urges us to not see architecture as a neutral background for our everyday lives. I would further argue that architectural drawings are not a neutral background for architecture, although they are in my experience generally perceived in such a way.

The Abstraction of Drawings

It is inevitable to lose something when representing a three dimensional space in a two dimensional drawing. Wigley (2021) speaks of “the secret lives of materials”. This partly refers to what happens outside the building, the lifecycle of the materials and how we do not know where

materials have been extracted from. But it also refers to – as I am more interested in, in this context – what is hidden inside the buildings. Plumbing, ventilation, electrical cables. These are secrets veiled by the architect, hidden in the building’s physical shape as well as in its architectural drawings.

What we can take from this, and as the title of Robin Evans’ essay *Translations from Drawing to Building* (1986) suggests, is that there is a gap between drawing and the physical matter it depicts. This abstraction leaves room for interpretation. Evans brings up an analogy between the translation of drawing to building, and the translation of languages: “Yet the [translation] from language to language does not appear to have the requisite evenness and continuity; things can get bent, broken or lost on the way. [...] I would like to suggest that something similar occurs in architecture” (p. 154). I agree with Evans, but would like to add that things can – other than get bent, broken, or lost – also be *discovered* in the translation of drawing to building.

Interpretation In Practice

An example of how this translation can take shape in architecture is found in *The Entire Situation* by Besler & Sons (2014). In this temporary exhibition you could find assemblages of walls, shaping three separate spaces in full scale. The drawings of the walls were made by an architect, to be built by construction workers. However, the walls in the drawings were not conventional. They were rounded and connected in unusual ways. When the construction workers then applied standard solutions onto the walls, the intersections became awkward. To me, this is a discussion on the gap between drawing and execution. About what gets lost along the way.

Another example – this time taking advantage of the interpretative freedom of drawings – is the exhibition *Alternative Histories* by Drawing Matter (2020). Eighty contemporary architecture offices were invited to participate. They were each handed a drawing out of Drawing Matter’s archive and were tasked with envisioning an alternative future for it. One of the participating offices was Fala Atelier. The drawing they were handed was a site plan for an office building,

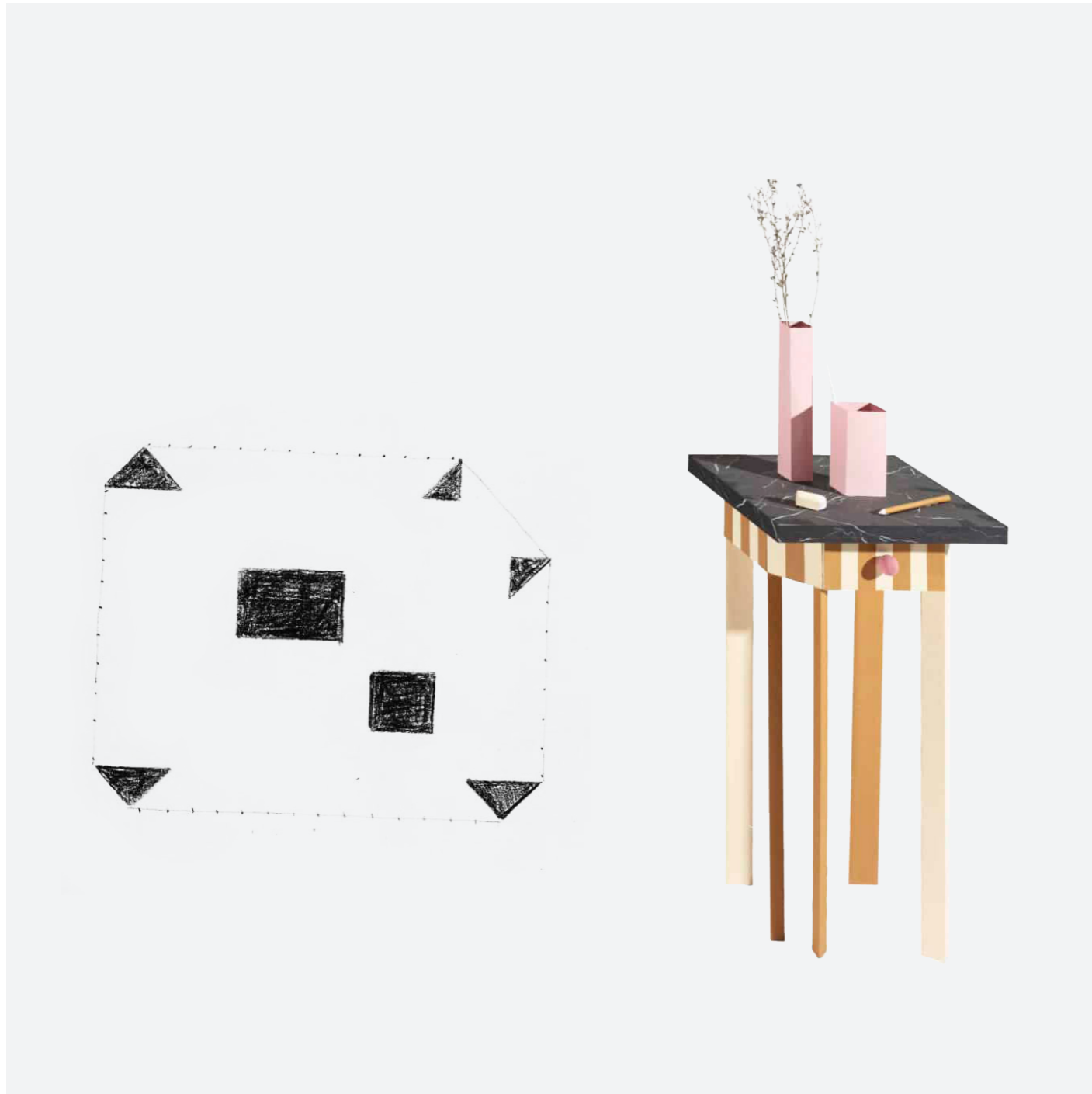

Fig. 2 / Site-plan for an office building. (Kahn, 1972). Licensed for non-commercial use by Drawing Matter.
Fig. 3 / Louis Kahn's site plan for an office building. (fala atelier, 2018). Licensed for non-commercial use by Drawing Matter.

made by Louis Kahn in 1972. When they interpreted the drawing, it became a nightstand in a full scale model. They did not remove any lines from the drawing but simply gave them a different meaning.

A difference worth noting between these two examples is that *The Entire Situation* tells us that

the abstraction of drawings has physical consequences, while *Alternative Histories* expresses that this can be utilised. I believe the first is needed to understand the other. However, for this thesis, I am more interested in the latter: using the interpretation of drawings as a method of design, and seeing the translation of drawing as an opportunity for discoveries.

Why Drawings Matter

We have established that drawings are abstracted, and that there is room for interpretation when reading a drawing – intentional or unintentional. Now I would like to explain why it matters. What makes the notion of drawings so important to me? In other words: *why drawings?*

To answer this question, I will take help from Evans (1986). He states that architecture is the translation from drawing to building. Before building, comes drawing. A problem with this becomes evident as Evans compares architects and painters: the painter will start with a sketch on a paper and then move onto painting on a canvas, a quite comprehensible jump between mediums. The largest amount of work goes into the canvas, the painting, the final product in itself. Similarly, the architect will start with a sketch on a paper and then move onto the drawing, in which the main effort is put. The drawing is the architect's final output. Although ideally the final *product* is not a drawing, but rather a building. However, the building comes afterwards – the architect does not construct it. You could say that what separates architecture and building is whether or not an architect drew the building beforehand. That is my answer to why drawings matter.

Representation

Now that we know it matters, it would be useful to have a common understanding of what a drawing is. Of course, a drawing can be many things. There is a bigger discussion to be had, which does not fit into the frame of this thesis introduction. But to put it shortly: drawing is a form of representation. Line drawing is the most fundamental form of it – using lines or curves to represent two- or three dimensional objects. The drawing being a representation means that it depicts something, without actually being the thing. Take a look at Magritte's 1929 painting *The Treachery of Images*, in which we see a pipe with a text stating (in French): "this is not a pipe". I agree: it is not a pipe, it is a painting of a pipe. The same way an architectural drawing is not a building, but a representation of it.

Goodman (1968) explains representation as one thing symbolising another. To this he adds that faithful representation is more than mere

imitation – in fact, abstraction is part of truthful representation. He writes:

"[...] the object before me is a man, a swarm of atoms, a complex of cells, a fiddler, a friend, a fool, and much more. If none of these constitute the object as it is, what else might? If all are ways the object is, then none is *the way* the object is. I cannot copy all these at once; and the more nearly I succeeded, the less would the result be a realistic picture."
 (pp. 4-5)

The Neutral Drawing

Yet again comparing architecture to other forms of art, representation is generally not assumed to be neutral when discussing painting in contrast to architecture (perhaps with the exception of realism). Looking at e.g. one of Monet's impressionist paintings of water lilies, we are aware that what we are looking at is the artist's interpretation of a scenery. We know it is not a neutral representation, it is loaded with his values in order to depict how he, the artist, perceives the scene. But regarding architectural representation, it seems to me that it often strives towards being "neutral", and additionally often succeeds in being perceived as such.

However, I have seen the rise of a discussion on the neutrality of rendering as a form of architectural representation. This can for example be seen in the handbook of norm critical visualisation by Fredriksson et al. (2019). They state that there is no neutral way to visualise the future city, and present eight different tactics to work norm critically with renderings, collages and paintings. Not to say that it does not exist, but I have yet to see the same discussion being as widely spread concerning orthogonal drawings, despite their abstraction.

Why is it then, that architectural drawings are often associated with neutrality? Chard (2016) explains: "Typically, architectural drawing leans heavily on the conventions of contract drawings, where there is a legal imperative for all parties to understand the drawings in exactly the same way" (p. 149). Though, in his project *Paradoxical Sciagraphy* he challenges this idea through attempting to find a way of drawing which does not rely on convention, but rather the unspe-

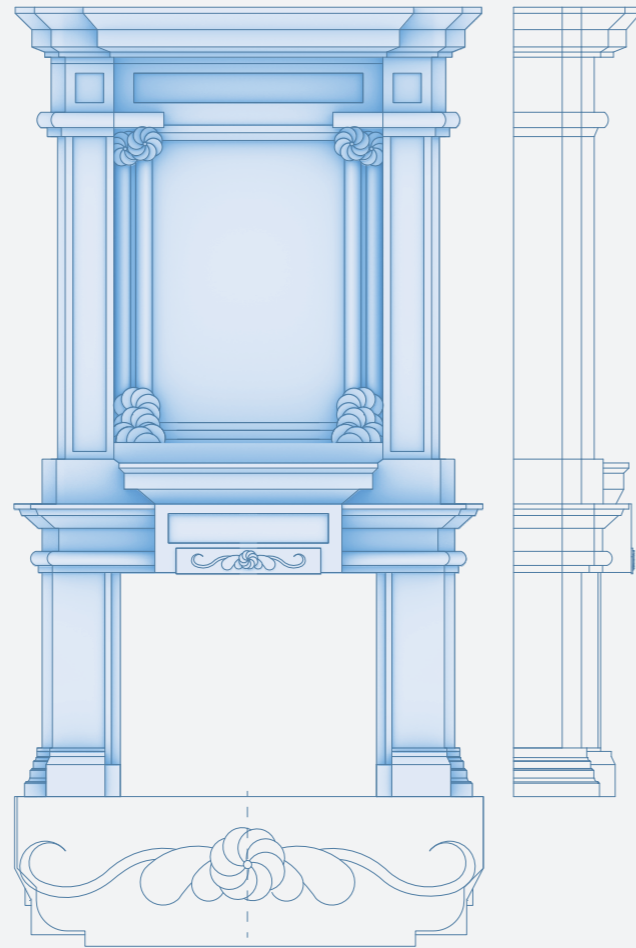

Fig. 4 / Ritning på Skoklosters slotts gårdfasad. (Most likely by de la Vallée, 1650's). CC PDM.

Fig. 5 / Fireplace. (Eklund, 2022). Courtesy of the artist.

cified method of paint throwing, in order to capture a part of life which is not covered by convention.

This is to say that while there are reasons for drawings to strive towards neutrality, there are also things to be discovered beyond the drawing as a legal document.

The Single Drawing

I want to address that I am aware that drawings are meant to complement each other. When drawing a project, the architect(s) usually not only makes a plan but also sections, facades, and construction and detail drawings. Often complemented with a 3D-model. You might be wondering, "so what" if drawings are abstracted?

That is why we have multiple of them – to make a whole. Why is it relevant to make interpretations out of drawings on their own?

To this, I would like to add that there are also cases where we do not have access to these multitudes of drawings. Anecdotally, when I got my apartment contract I had only ever seen the plan drawing. There were no pictures from the apartment itself, only general ones from a similar building, and I was not allowed to visit the inside beforehand. This is oftentimes the case with student housing, in my experience.

Another example is that when studying an architectural project, you do not always have full access to all drawings. This could either be because they are not properly digitalised, locked behind a paywall, or if it is an older building the drawings might have been damaged or lost. To get an example, take a look at the master's thesis *Do not touch? Speculations on historical intentions and their place in cultural heritage* (Eklund, 2022), where the author uses her interpretation of archival drawings in an attempt to communicate the original intentions of "the unfinished hall" of Skokloster. For instance: from an archival, low resolution section drawing, Eklund finds that there was supposed to be a fireplace in the hall. By interpreting the drawing with the help of her research on the existing parts of the castle, she is able to make an educated guess on what the fireplace was supposed to look like. In reconstruction projects like Eklund's, the interpretation of single drawings becomes a vital part of the process.

A Creative Use of Drawings

Even taking aside that there are cases where we do not have access to more than one drawing – or where the drawings are aged, damaged, or somehow modified – I would still like to argue that there is value in interpreting drawings on their own.

In order to explain why, it is important to first understand drawings from a norm critical perspective. Weisman (2000) states that "architecture [...] is a record of deeds of those who have the power to build" (p. 86). Those with the power to build does not necessarily refer to architects but rather their clients: developers and

landlords, and those with the power to influence their decision-making (in the context of Sweden today). Whether you are able to get in hold of this power is to a certain extent determined by your habitus. Now, taking Weisman's statement and in extension adding it together with the previous statement based on Evans (1986) – that architecture is the translation of drawings – we can claim that "the translation of drawing is a record of deeds of those who have the power to build". Therefore, this translation – or interpretation – of drawings cannot be considered neutral.

With this in mind, I would like to view the interpretation of drawings as an opportunity for discovering design beyond norms and conventions. For a moment, switching the narrative that there is room for interpretation in drawings "because of" their abstraction, to "thanks to" their abstraction. By interpreting drawings in different ways, we open up for the creation of alternative stories. For this sake, it does not matter whether drawings are read on their own or not.

In the book *Drawing Futures*, Allen and Pearson (2016) describe architectural drawing as an art form that is not dying, despite the automatisa-tion of the last thirty years. The book presents sixty different projects which work with drawings in unconventional ways. Among other questions, they ask: "How might critical re-readings of established histories offer new approaches for the future, and how might reframing the past shake the fundamental notions that we take for granted in drawing practice?" (p. 5). This project aims to answer that question in another way and to expand the repertoire of drawing usages.

There is an apparent interest in drawings and I believe they will continue to exist in architectural tradition in the foreseeable future. However, I am not so sure that they are going to look the same, as our norms and conventions might not apply to whoever comes after us. Our preconceived notions about what a drawing looks like, what it represents and how, might come to be challenged. This is why I think it is an interesting exercise to experiment with the interpretation of drawings already now.

Drawings and Orientations

“Orientation” is a word that describes the relationship between your body and the space, objects, and architecture around you. It deals with positioning, direction, and alignment. The lines you follow – in space and in society – determine how you are oriented. A body following movements that are structurally repeated, may appear to be neutrally oriented. (Ahmed, 2006)

When reading an architectural drawing, the architect relies on certain rules to orient themselves. Perhaps the reading of drawings is a skill particularly possessed by architects. With a legal compulsion we practice the rules of drawing, aiming to orient ourselves in alignment with the industry. These rules – or conventions – are imprinted in us to the point where when we read drawings, we assume they follow the standards we have learnt, unless clearly stated otherwise. The reading is done by the architect in such a routinely manner, I believe the act is often not even reflected upon as a subjective interpretation. But as Goodman (1968) states: “the most neutral eye and the most biased are merely sophisticated in different ways. [They] differ not in how much but only in how they interpret” (p. 9).

Queer Disorientation

What, then, is the alternative to being oriented in alignment with your surroundings? In *Queer Phenomenology*, Ahmed (2006) compares disorientation to queerness. A straight body is oriented in alignment with the world, follows the anticipated lines, and has capacity to act within its space. A queer body is disoriented as its ability to be involved with the world around it is weakened. Ahmed writes:

“The ground into which we sink our feet is not neutral: it gives ground to some more than others. Disorientation occurs when we fail to sink into the ground, which means that the “ground” itself is disturbed, which also disturbs what gathers “on” the ground.” (p. 160)

When the ground is disturbed, it becomes disori-

enting, which can reflect the experiences of a queer body. To queer space is to disturb the order of it. (Ahmed, 2006)

Drawings and Queerness

How does the notion of queer disorientation translate into the reading of drawings? To me, the answer would be to disturb the rules which we use to orient ourselves in the drawing. Challenging the dominant conventions, disrupts the “ground” of understanding. If the meaning of a symbol is undetermined and freely up for interpretation, the drawing is no longer read with ease, and the reader might become uncomfortably aware of their position – feeling disoriented.

In *Noncon Form*, Barrett (2017) describes non-conventional architecture as a blend of various elements, both past and potential (p. 144). Further, she argues that queerness in architecture is not about fixed or absolute qualities, but rather about the fluidity of those qualities, and their ability to take on various forms. This suggests that the ability to read or interpret things in different ways, rather than adhering to any *one* definition, is inherently connected to queerness.

In summary, queerness celebrates the multiple layers of meanings and interpretations. Through challenging the conventions of architectural drawings, we put ourselves in a position of disorientation, additionally inviting ourselves to engage in creative acts of perception and understanding.

//

Part Two

Method

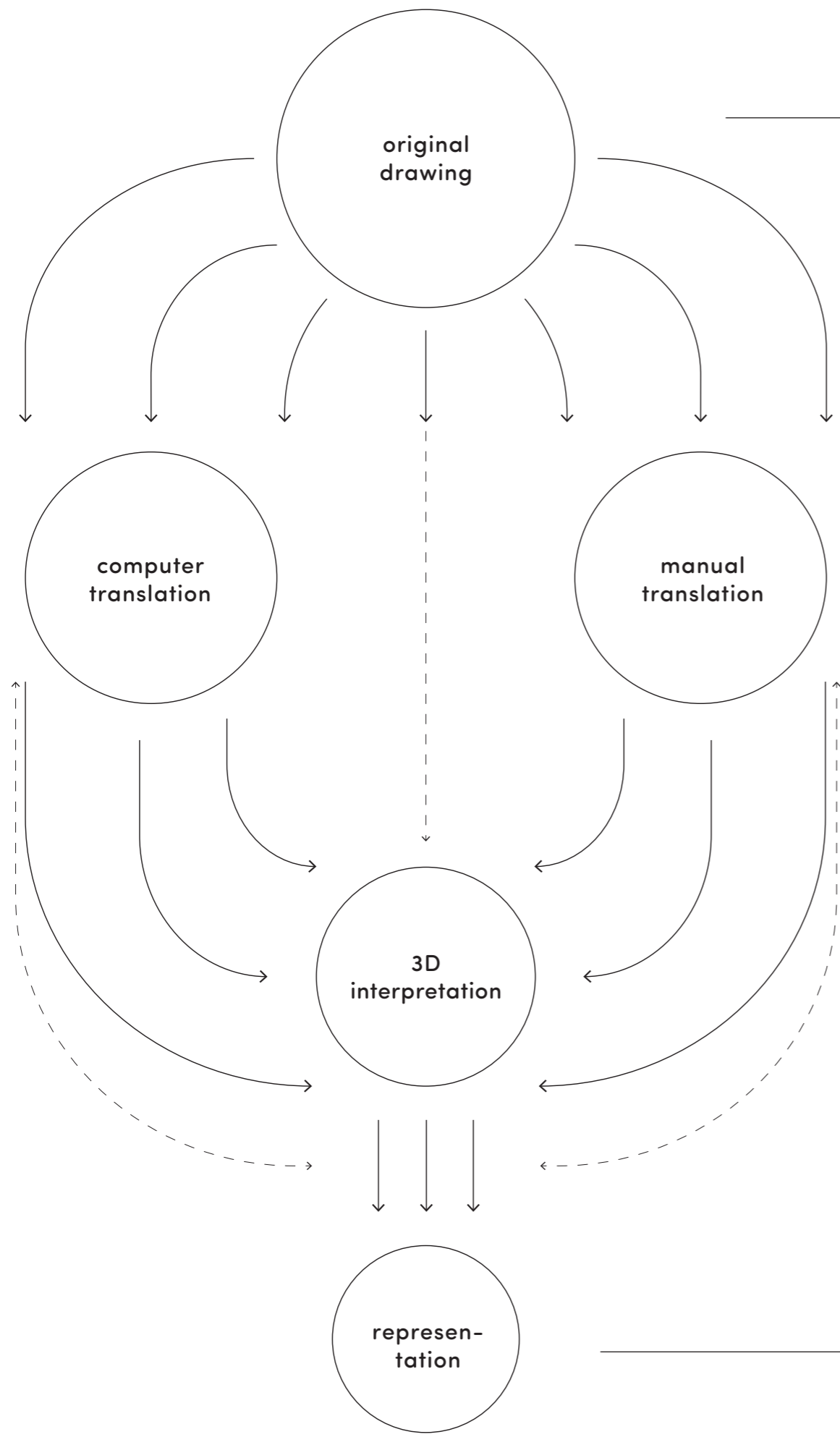

general idea of the process.....specified process

1. Drawing

The first step of the interpretation process is having a drawing to start from. This could be an analog or digital drawing, of any type or scale in any context.

1. Find a plan line drawing with a sufficient amount of detail, preferably hand drawn

2.a. If in a physical format, scan the drawing into a digital format

2.b.a. Vectorize it by manually translating it using a CAD-program

2.b.b. Vectorize it through computer translation, using Illustrator. Use image trace and change into the following settings for higher accuracy: 2 colours, 100% paths, 1px noise. Finalise and split. Delete the fill of all negative space. Invert fill and line colour of what is left

2.c. Combine the translations as you see fit

2. Translation

If the original drawing does not meet your needs to begin the 3D-interpretation, translate the drawing into the needed format, manually and/or using automated trace.

3.a. Put the translated drawing into a 3D-modelling software such as Rhino

3.b. Interpret the drawing from the ground up. See next page for (mis) interpretation suggestions:

3.b.a. Start by defining direction and depth of the negative spaces

3.b.b. Define the borders of the spaces, such as walls and ceilings, and how to move between them

3.b.c. Work your way through the drawing bit by bit, interpreting things on a smaller scale such as furniture, until all lines are charged with some kind of meaning (symbolic or material)

3. Interpretation

Take the drawing from 2D to 3D through interpreting its different symbols and properties (see next page).

4. Representation

After interpreting the drawing in 3D, it can be translated back into 2D to represent the project. This is where the architect's work ends. But the process may repeat itself.

4.a. Export selected views

4.b. Represent the project using a combination of exported lines, the original drawing, and post-production rendering

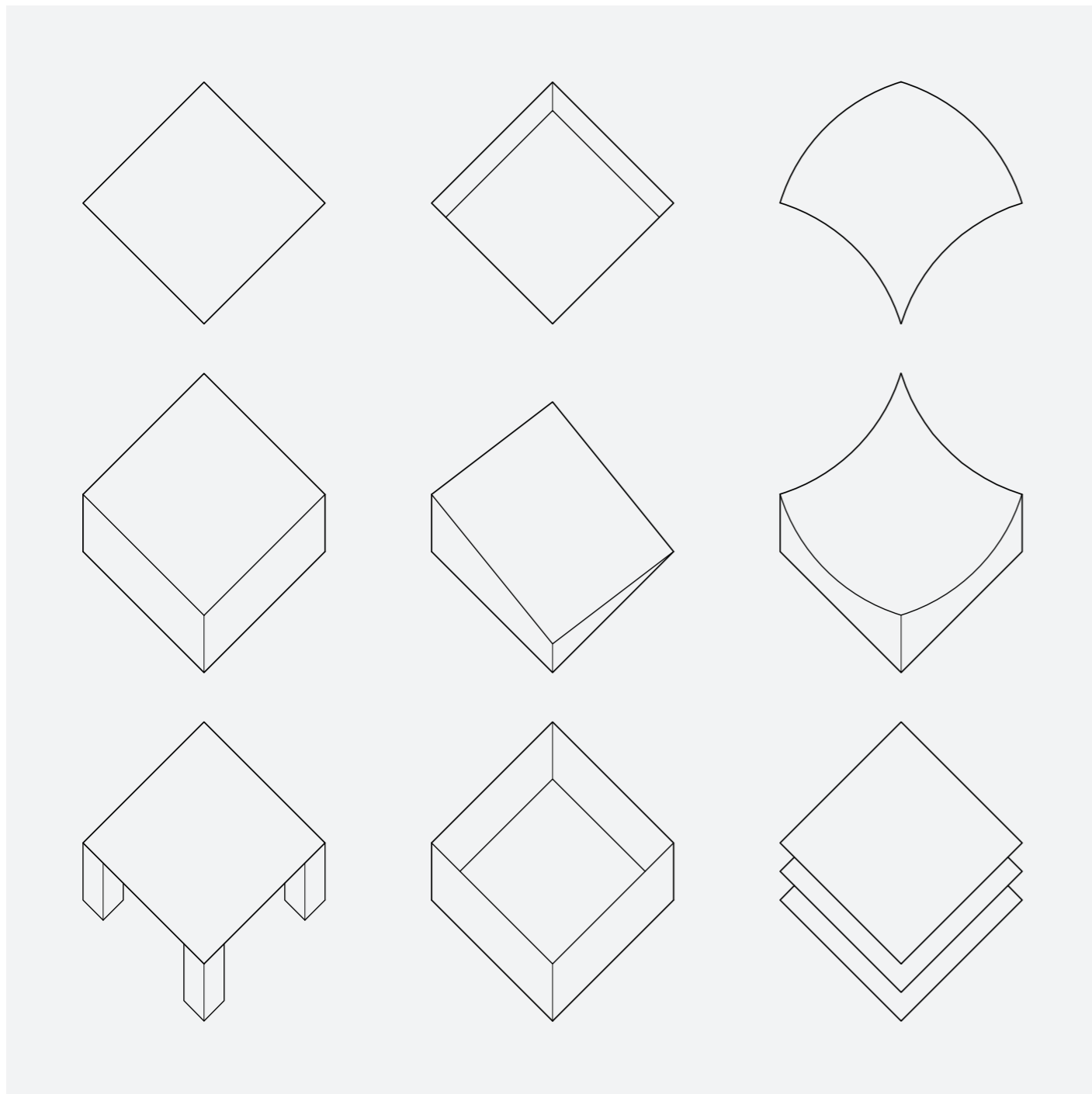

Axonometric drawings / nine situations which could look the same in a plan drawing (by author)

Drawing: Conventions and Interpretations

This section introduces the 16 categories of things I have found you can (mis)interpret in a drawing. In part the text explains the basics of the conventions which I have brought with me from my five years of architectural studies. These conventions are explained through my own experience to give transparency to the base on which my interpretations are built. And in part

the text exemplifies what (mis)interpretation in the particular categories could look like.

Type

There are different types of drawings. A plan drawing would normally be of the object as seen from above, like a map, and cut horizontally so that its inside is visible, portraying any of a

building's floors (unless it is a roof or site plan). A facade would be a drawing of one of the object's faces, as if standing parallel to it. There are more types of drawings but to name one last example, a section drawing cuts through the object vertically, and draws it in parallel to the cut.

To (mis)interpret the drawing's type, could for example be to read a plan as a facade. The drawing of the object from above, would then instead be read as a drawing of one of the object's faces. This could in extension impact the way you interpret for example symbols on the drawing, symbols marking say furniture on a plan would probably not be perceived as furniture on the facade.

Scale

A drawing of an object is made in a certain scale in relation to the object, such as 1:1 (in which the drawing is the same size as the object), 2:1 (in which the drawing is double the size of the object), or 1:100 (in which the drawing is one hundredth the size of the object).

To read the drawing in a different scale than originally intended, would make the object grow or shrink in size. This could for example change the object's functionality. If you were to believe a 1:10 drawing of a regular sized chair was instead made in 1:1, the chair would suddenly not function as a chair, as it would be too small to sit on (at least for a human).

Context

"Context" refers to other information concerning the drawing, such as the age, site, or program of the object it depicts. Depending on what context you believe the object is placed in, it is possible you would assign different characteristics to it.

Were you for example to receive a plan drawing and asked to interpret it in 3D, it is likely you would interpret it as one thing if given the context it is a drawing of a home in the Swedish countryside, and another if given it is of a suburban American home, since people in different cultures and climates often use different building materials and build in different architectural styles.

Intention and Detail

"Intention" is about what information is assumed to be present in the drawing – the drawing's purpose. The purpose changes for example depending on the type and scale of the drawing. But an architectural drawing would look different from an electrical scheme even if both of them were to depict a plan of the same building in the same scale. In that sense, "intention" also has to do with the details of the drawing.

A drawing is always abstracted in one way or another. (Mis)interpreting the drawing's intention and detail could mean to interpret the drawing's abstraction as intentional and representing a physical lack of detail, or otherwise interpret details in its place. Imagine you are looking at a drawing of a door, but the door does not have a door handle on the drawing. Then you could either believe that this drawing is supposed to show the door in its full detail and that it is a door without a handle, or you believe the door handle is abstracted from the drawing but that the physical door, which the drawing depicts, would still have a handle.

Medium

A drawing can be made by hand, or made digitally using whatever program is preferred. The chosen medium has an effect on the outcome of the drawing and if it is in vector, pixels, or purely physical. In addition, different programs might have different standards for line weights, and when drawing analogically, the pens and tools you choose will change the outcome of the drawing.

(Mis)interpreting a drawing in the category of "medium", could for example be to read an analog drawing as a digital one. When reading an analog drawing as analog, you might still interpret a line to be straight even though it is a slight bit wobbly, since it could be due to a shaky hand. But if you were to read the same analog drawing as a digital drawing, translating the wobbly analog line to a vector, you might interpret that the object the drawing depicts must be wobbly too – because why else draw a wobbly line, when a completely straight line is not only perfectly manageable but might even be easier to draw in a digital program.

Modifications

The “modifications” of a drawing is related to “medium”, but could be things that happen as a result of the process of making the drawing, of the ageing of the drawing, or of the transferring of the drawing. For example still slightly visible erased lines, or bleaching accumulating over time as the paper ages, or pixelation as the drawing is saved in low resolution.

To (mis)interpret modifications could for example be to read a coffee stain as an intentional part of the drawing and believing it represents something physical.

Direction

“Direction” is about whether any object depicted on a drawing is moving upwards or downwards from the base plane of the drawing. Say you are looking at a plan drawing with a square on it. You then have to interpret if the square marks something that digs into the plane (a hole in the ground?) or if it builds upwards from the plane (a block object?). Alternatively if it is a surface with no volume at all, negative nor positive.

Depth

“Depth” determines how far any object on a drawing is moving upwards or downwards from the base plane of the drawing. Let us say that the square previously mentioned under “direction” is in fact an upwards building object. Interpreting “depth” is then to read the height of the object – whether it is a single nanometre, five centimetres, or a hundred metres tall.

Symbols

A drawing of an object is made out of symbols, however literal or vague they are. A symbol can for example be a letter, a figure, or a line. An example of a more literal drawing symbol could be that of a wall on an architectural plan, which is often symbolised either by two parallel lines or a single thick line, marking the physical shape of the wall. An example of a more symbolic symbol could be the triangle which points towards an entrance on the plan drawing of an entrance floor – the triangle does not actually exist as physical matter but exists as a symbol to help the reader orient themselves in the drawing.

To (mis)interpret symbols on a drawing, could be

to read symbolic symbols as physical shapes or to read literal symbols as symbolic symbols; for example looking at an L-shaped wall and interpreting it as the actual letter “L”, which would typically stand for a linen closet (linneskåp) on a Swedish plan drawing.

Line Type

Lines are, as mentioned, also symbols. But in a line drawing, lines as symbols are essential and the different qualities of the lines also have their own conventions which can be open for interpretation. There are different types of lines, including continuous, dashed, and dash-dotted. The different types can serve different functions. A dash-dotted line in a plan drawing normally shows something that is above the cut, while a dashed line could be used to show something hidden beneath, or to mark a border, or to mark something optional (for example, a dashed line could be used to mark a wall that could potentially be built to separate the kitchen from the living room).

(Mis)interpreting line types could be to have other rules for what the different types are used for, perhaps reading the opposite way of how they were previously described, so that dash-dotted lines mark something beneath and dashed something above. It could also be to read a dashed line which was intended to show something optional instead as something hidden beneath, or vice versa.

Line Weight

A line’s “weight” refers to the thickness of the line. Line weight is often used as a tool to put hierarchy into a drawing. What thickness a line should be assigned can depend on different things, it can for example have to do with permanence: having vital structural elements drawn in thick lines, and interchangeable furniture drawn in light lines. It can also have to do with proximity and distance: an object immediately cut through having thicker lines than an object seen from afar, in the background. Line weight could also be used in a drawing as a tool to put value into what the reader should put their attention to: looking at architectural plan drawings, you might find a drawing of a house in thick lines, and beside it trees in thin lines. This does not have to do with permanence as the trees could well

enough stand for longer than the house, and it does not have to do with proximity and distance as the cutting plane goes straight through the trunks. It is simply then that the main object of the drawing is the house, and the trees are there to give background and context.

(Mis)interpreting line weight could then be to follow a different hierarchy when reading the drawing, such as reading distance when permanence was originally intended. It could also be to interpret that at any certain line weight, the line becomes physical itself – that it does not mark the outline of an object but rather in itself marks the object in its entirety.

Layers

“Layers” describe objects hidden in a drawing, behind other objects or in front of the cutting plane. One could argue then, that dashed and dash-dotted lines solve precisely that, or perhaps that it is rather a matter of “intention and detail” if one expects whether these hidden objects would be drawn or not. However, one thing “layers” captures that these other categories do not, is the problem that could occur when objects perfectly align. In a flat, two dimensional drawing, you would not be able to tell if two or more objects were to exist if they are identical and in parallel to both each other and the viewing plane. That describes one way to (mis) interpret a drawing in the category of “layers”. Another way would be to assume that there were two identical objects lined up in this way, when there was not.

Function

“Function” refers to any function associated with an object in the drawing. Specific functions are often marked with symbols. For example, the letter “K” normally stands for an object functioning as a refrigerator (kylskåp) in Swedish architectural plan drawings.

(Mis)interpreting function could include both assigning a new function to or removing function from an object in a drawing. This could happen as a result of (mis)interpretation in a different category, such as interpreting a symbol as a symbol for something else, or as the example under “scale” where the chair lost its function as a chair because it was read in a scale where it

would be too small to function as a chair.

Material

Depending on what type of drawing you are looking at, it is not for certain that the material(s) of the object(s) in the drawing are disclosed. In a large scale drawing, perhaps you can see the walls built brick by brick, but on a smaller scale you might be left to guess by context and wall thickness. It is quite straightforward then, that the (mis)interpretation of materials on a drawing, is about making assumptions of what the object (or objects) on the drawing is built out of, for example believing the drawing is of a brick house when the house is in fact made out of wood.

Texture

“Texture” is quite similar to material, as it is dependent on it. A brick wall does not have the same tactile qualities as a wooden wall. But even when knowing the material of the object, you cannot be sure of its texture. A clean cut, sanded wood has a different texture than a roughly cut wood. (Mis)interpreting texture is simply about interpreting the texture of the object(s) in a drawing.

Colour

Interpreting the colours of a drawing can have a twofold meaning. It could refer to potential colours that are on the drawing itself, in which case I would argue the colours would be a type of symbol. Rather, I would say it refers to the colours of objects in the drawing. These definitions could of course be intertwined, that the colours in the drawing itself are literal symbols of the colour of the object they represent. Whether or not there are colours on the actual drawing, (mis)interpreting colour means to read the drawing’s object(s) in different colours, for example assuming that a wall is white when it could be yellow.

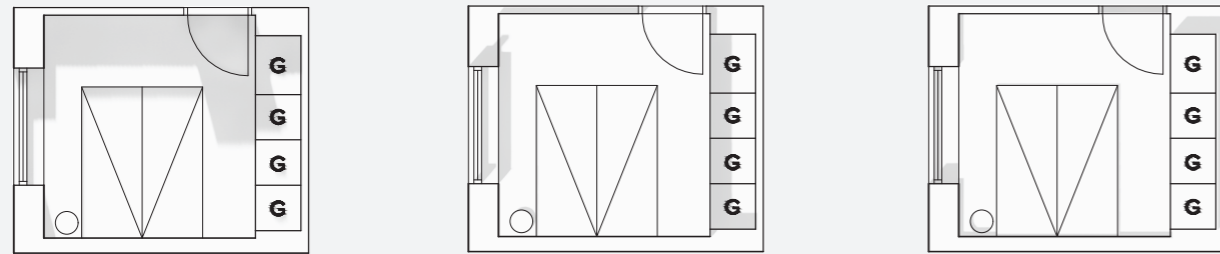

Type

Direction I

Direction II

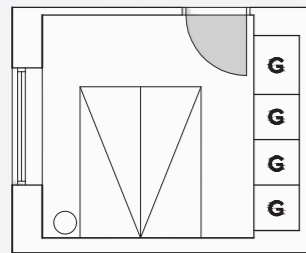

Scale

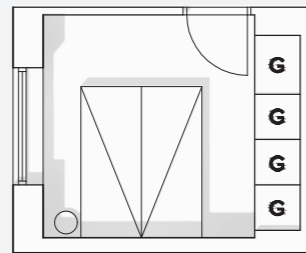

Depth I

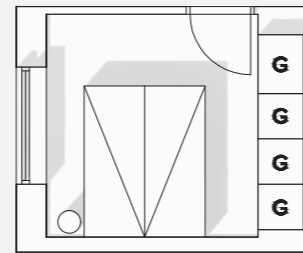

Depth II

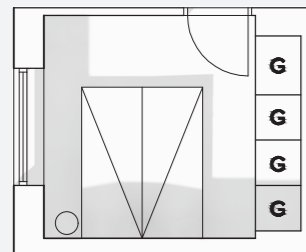

Context

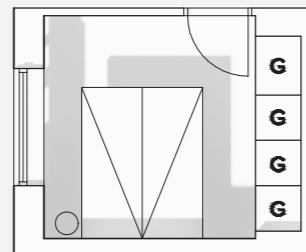

Layers I

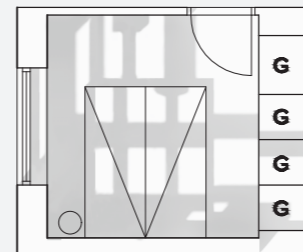

Layers II

Plan drawings / nine versions of the same plan (by author)

Explorations

The explorations introduced in this section were made in order to develop a deeper understanding of the different categories of (mis)interpretation, discover more of them, and to explore the method. They do not follow the specified process found on p. 19, rather they are part of the research which helped me figure out the specifics of that process.

Some of these explorations offer more of a design challenge while others (namely direction, depth, and layers) are more illustrative examples of how their categories of (mis)interpretation can be used as tools to solve different challenges which intentional misinterpretation presents.

Type

When reading the plan as a facade, everything I thought I knew about the drawing is suddenly challenged. Nothing can be directly translated, as facade drawings generally do not use the same symbolism that plan drawings do. The old bed I interpret as a door and the bedside table as either a ventilation hatch or a cat flap. The old window could be led tubes, the old door a window with a small screen roof. The old wardrobes simply a decorative relief.

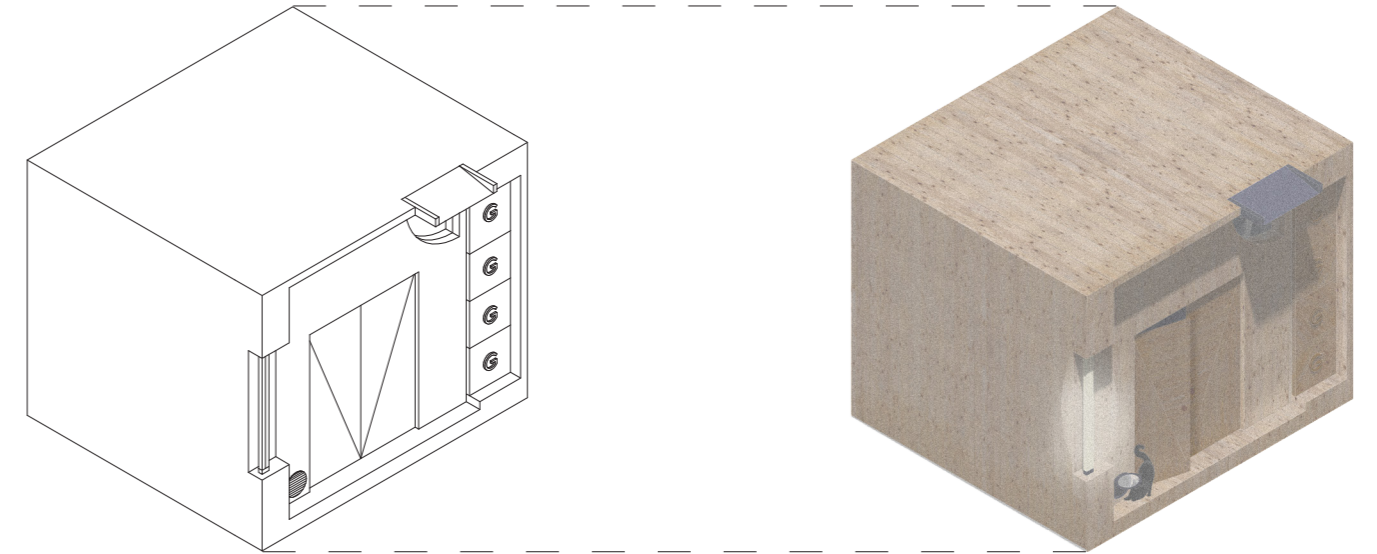

Scale

When interpreting the plan in 1:3,75 instead of in 1:100, I read it as the lid of a small storage box. The functions have to change in order to suit the new scale. The symbols representing the bed, I instead interpret as a card holder. The old door arch I see fitting as a hole in which to stick your finger in order to open the box. And the old windows I read as a symbol for a hinge.

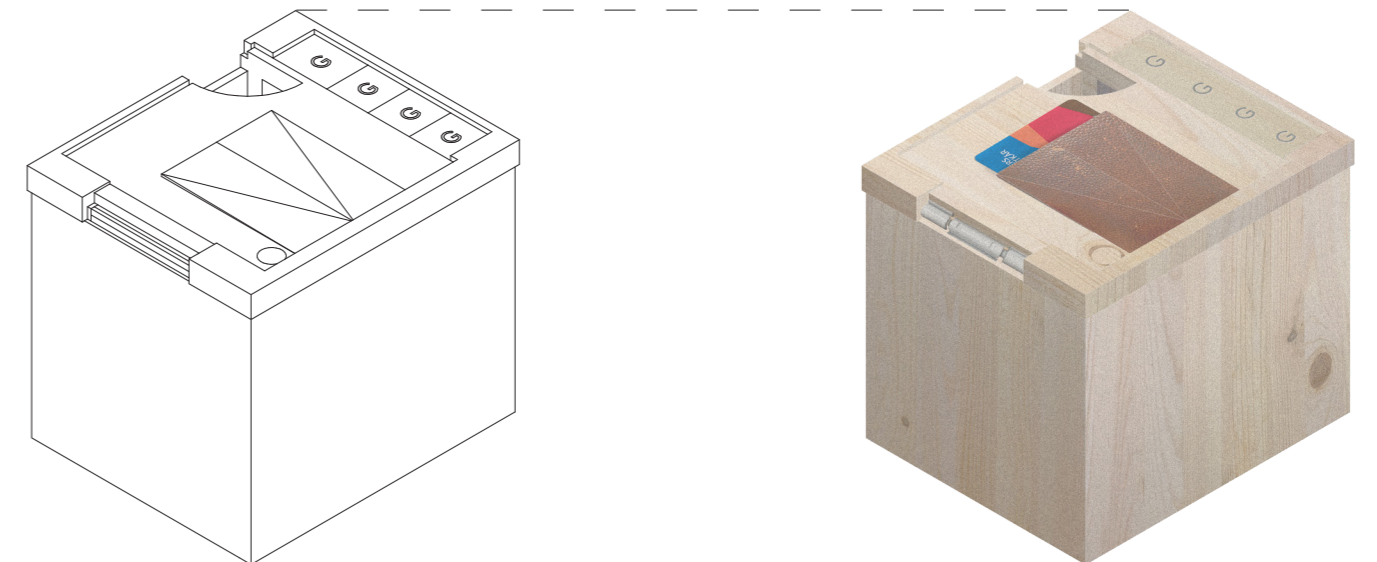

Context

When changing the program of the plan to being outside, I do not read everything as intuitively anymore. I would still read the door as a door, and the window as a window. But I would not assume the bed to be a bed when it is outside, instead I read it as a water feature. And G might not stand for garderob (wardrobe) – I interpret it as a G for gardening. The bedside table could be an infrared heater.

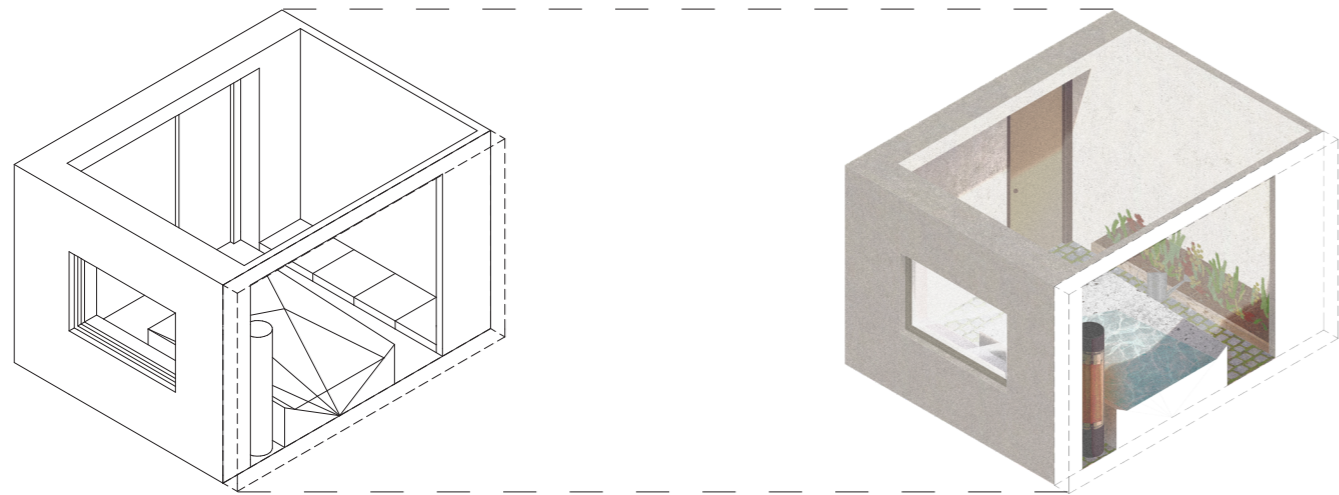

Direction

These drawings are meant to illustrate how we cannot tell from a plan drawing (where we have the X and Y-directions set) where lines are headed in the Z-direction. Perhaps the bedroom is on a raised platform with the bed sunken into the floor. The two are inverted versions of each other (if one of them was mirrored, they would fit perfectly together in a cube) yet they look the same in plan.

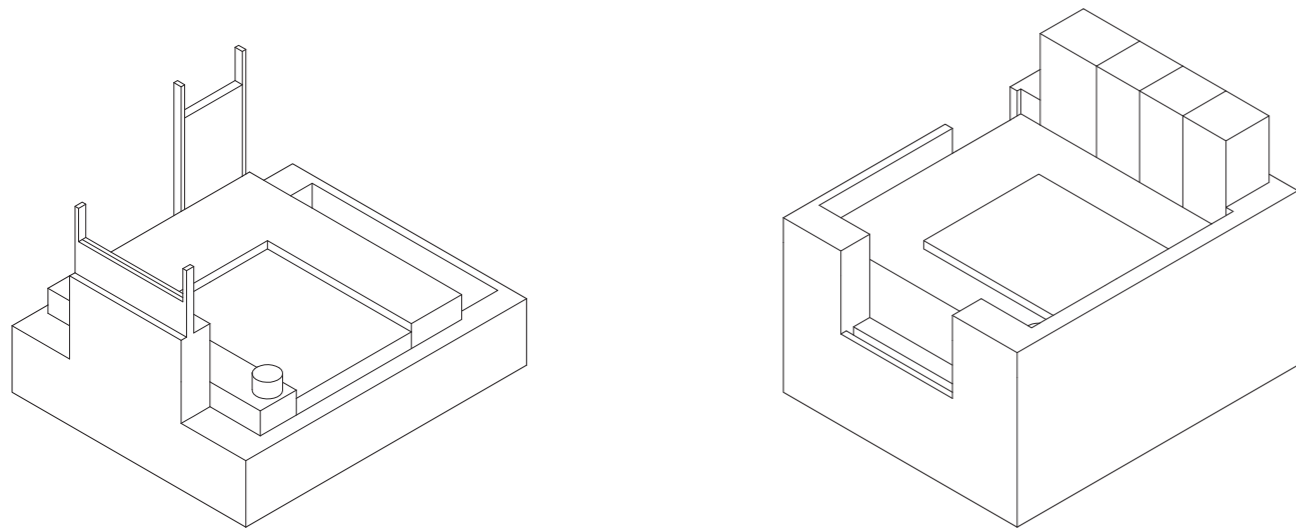

Depth

Even when having an idea of what direction everything is supposed to go in, we do not know how far in that direction it goes – what the highest and lowest points are. These illustrate two models where the heights are opposite (the lowest point in one is the highest in the other).

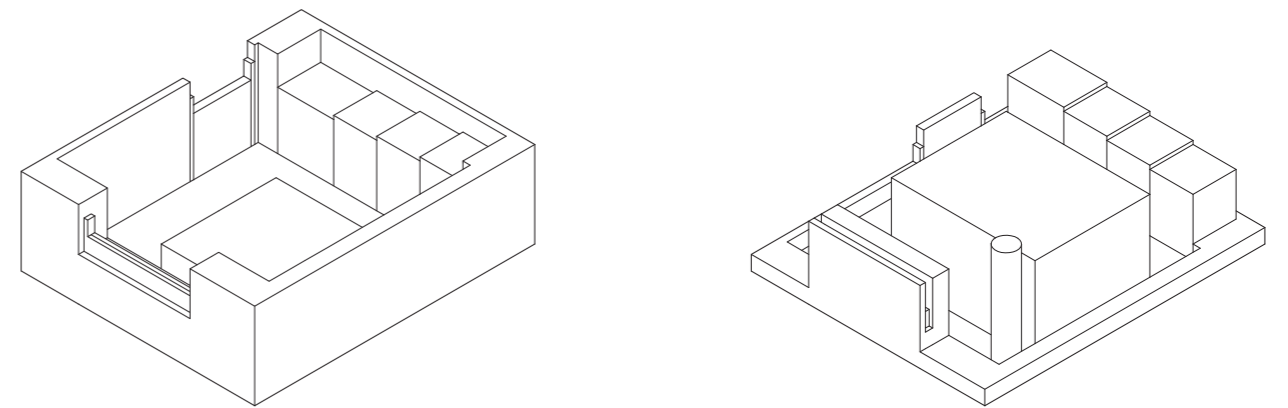

Layers

The left one is an illustration of how objects, as they are seen from above, can cover things happening underneath them. Hiding their own inwards inclination or covering other objects beneath. The right one is an illustration of things that could be hidden above the cut (specifically a plan cut 160 cm above the floor plane) – beams, ventilation pipes, holes in the wall. Things which completely change the atmosphere of the room, but that you could not see by solely looking at the plan.

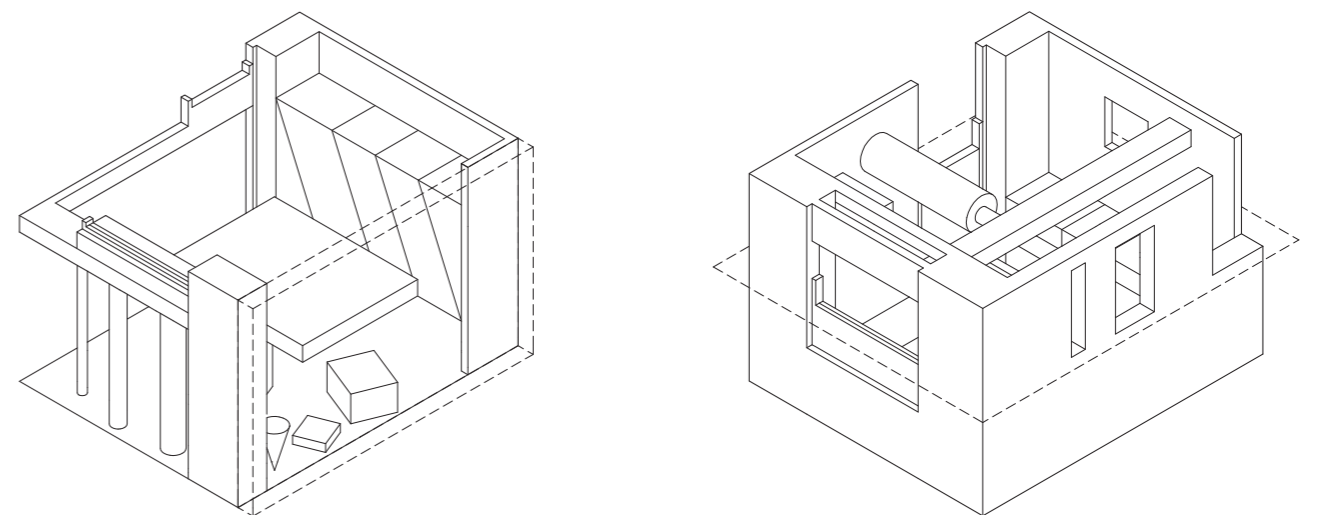

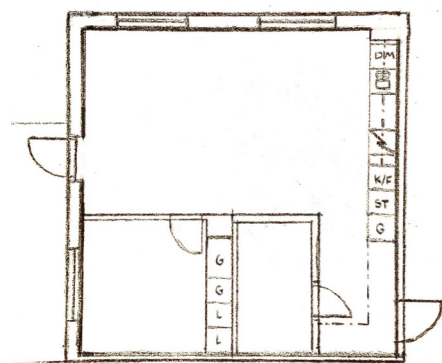

01. *P: analog*
A: make drawing
O: scan to .pdf

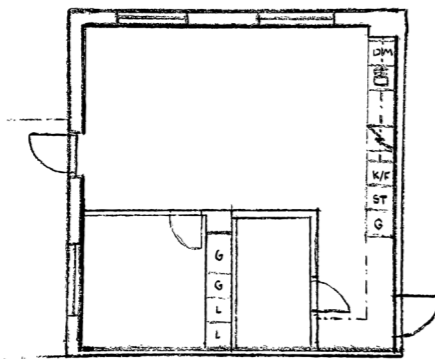

02. *P: Illustrator*
A: trace
O: export as .png

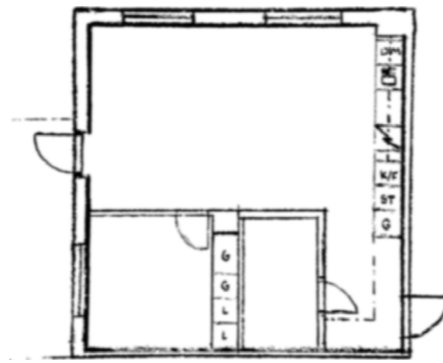

03. *P: Photoshop*
A: blur
O: save as .png

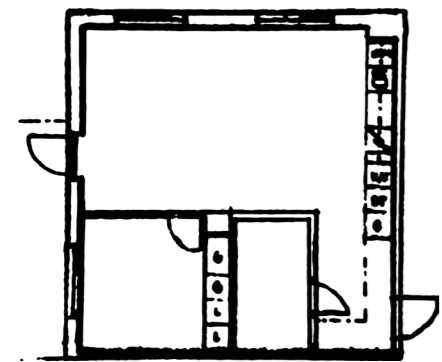

04. *P: Illustrator*
A: trace
O: export as .png

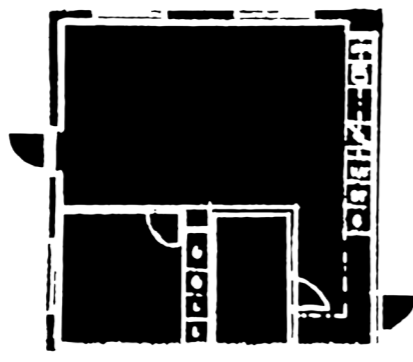

05. *P: Photoshop*
A: fill
O: save as .png

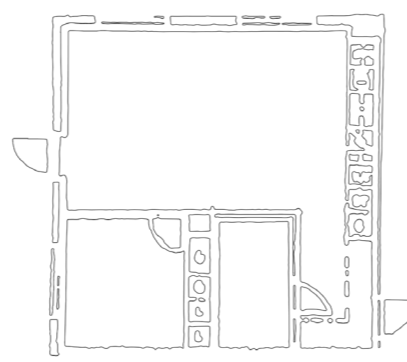

06. *P: Illustrator*
A: trace, invert line and fill
O: export as .dwg

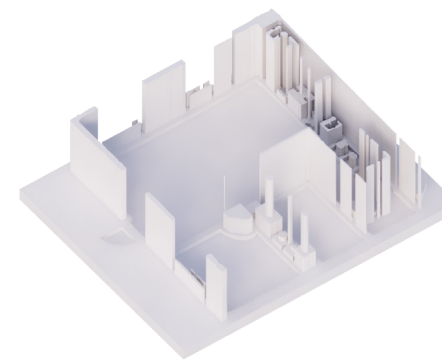

07. *P: SketchUp*
A: extrude different heights
O: export as .dwg

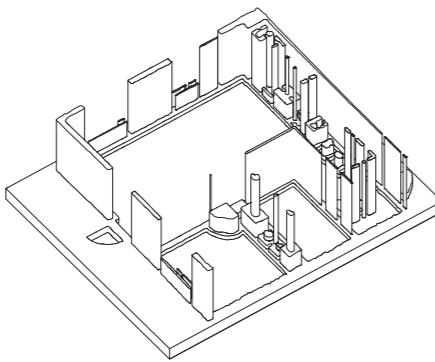

08. *P: AutoCad*
A: trim excess lines
O: print as .pdf

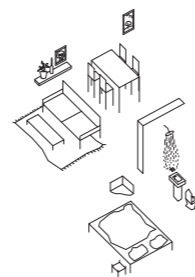

09. *P: AutoCad*
A: create furniture
O: print as .pdf

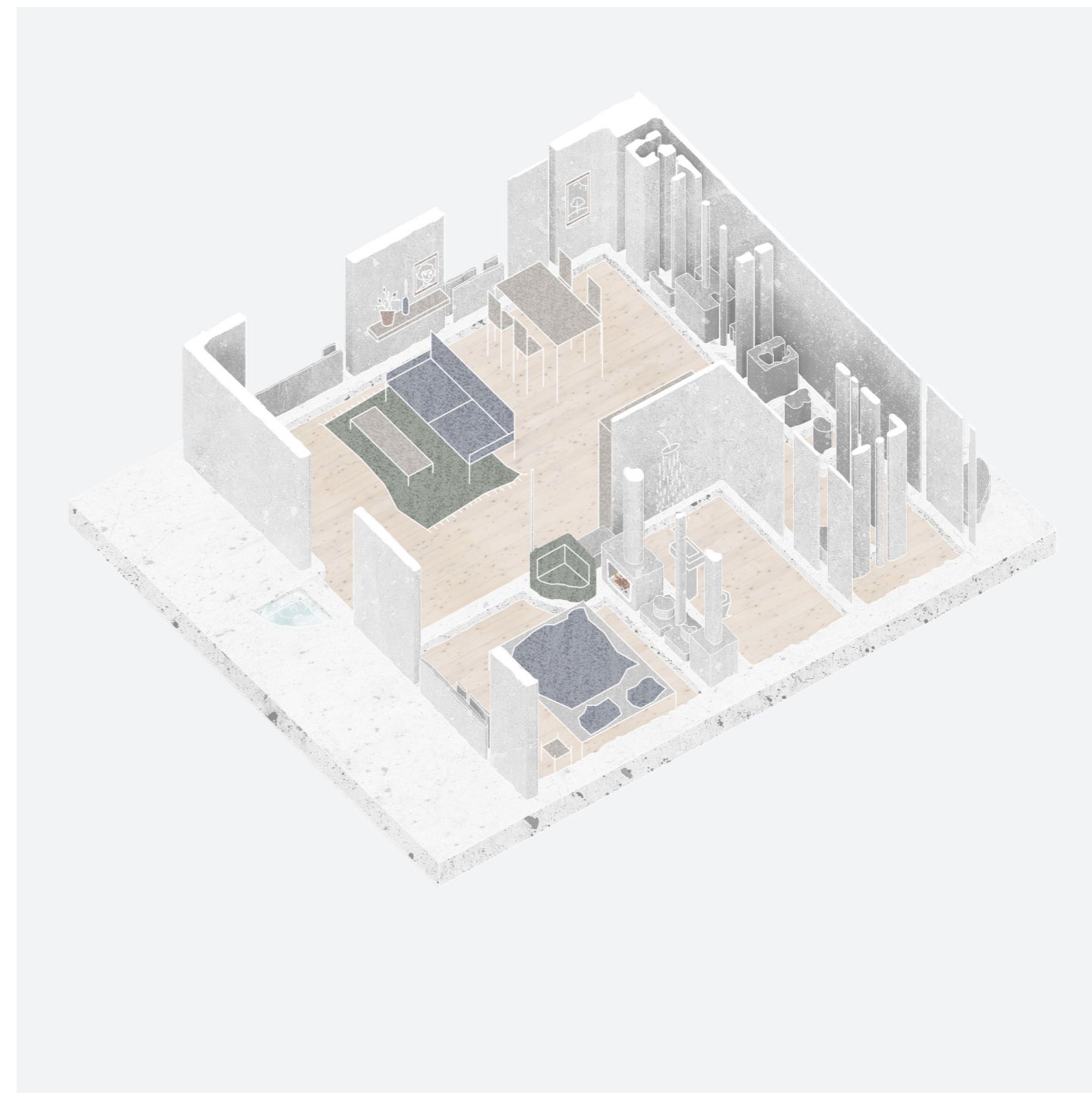

10. *P: Photoshop*
A: texturise
O: save as .pdf

Medium, Modifications

The exploration begins with me making a plan drawing of my apartment by hand, in scale 1:100 (not pictured in scale). The idea is to produce it quickly. The drawing is made using a single, rather thick pen, which leads to a reduction in detailing, rugged lines, and all lines being fairly thick. The drawing is then scanned, turning physical lines into pixels, to be vectorised.

This exploration touches mainly upon the categories of "medium" and "modifications" – digging into the translation between analog and digital, and between vector and pixel, also making modifications along the process, affecting the translation between mediums.

Part Three

Site



Site plan / site in relation to the city

0 2 km

The Labbera Peninsula

Rådasjön is a lake located in between Mölndal and Mölnlycke. On the east side of the lake, you can find the Labbera peninsula, which largely consists of a nature reserve with open pastures, temperate broad-leaved deciduous forests (with mainly oak and beech), and forest beaches. The project site is on the south-western edge of the peninsula.

Råda Säteri

Close to the mainland connected to the peninsula, is Råda Säteri ("the manor of Råda"). The manor is open all seasons, but during summer, the gardens bloom with flowers, fruits, and spices. Råda Säteri is home to multiple associations such as a tea and a beekeeping society, a fishing club, and a horse riding club



Site plan / site located on the Labbera peninsula

0 200 m

with about twenty horses partly living on the open pastures of the nature reserve. Here you can also find multiple shops and cafés in buildings dating back to the 1700's. The manor itself is owned by the municipality and it is, since 1969, a listed building for its historical importance. The area is important both for its historical values but also as a centre of recreation.

Slottsviken

Slottsviken ("the castle cove", originally known as Villa Denninghoff) is also located by Rådasjön, opposite the Labbera Peninsula, close to the castle of Gunnebo.

In 1888, about a hundred years after the castle of Gunnebo was built, it was bought by



Fig. 6 / Slottsviken. (Oberger, 2014). CC BY-SA. Edited by author.

a wealthy merchant named Wilhelm Denninghoff, and his wife Jeanna Denninghoff. After the couple had lived in the castle for about a year, their daughter was married and she received the castle as dowry. The newlyweds moved into the castle, and Wilhelm and Jeanna decided to build a summer residence on an adjacent plot – Villa Denninghoff. The villa was drawn by the

architect Louis Enders, and was completed in 1898. (Ackerhans, 2023; *Slottsviken*, 2023)

Villa Denninghoff changed names into Slottsviken in 1929, after the building was turned into a pension, as the new owners did not want the Denninghoff-name to be associated with it. (*Slottsviken*, 2023) In 1951, Slottsviken was

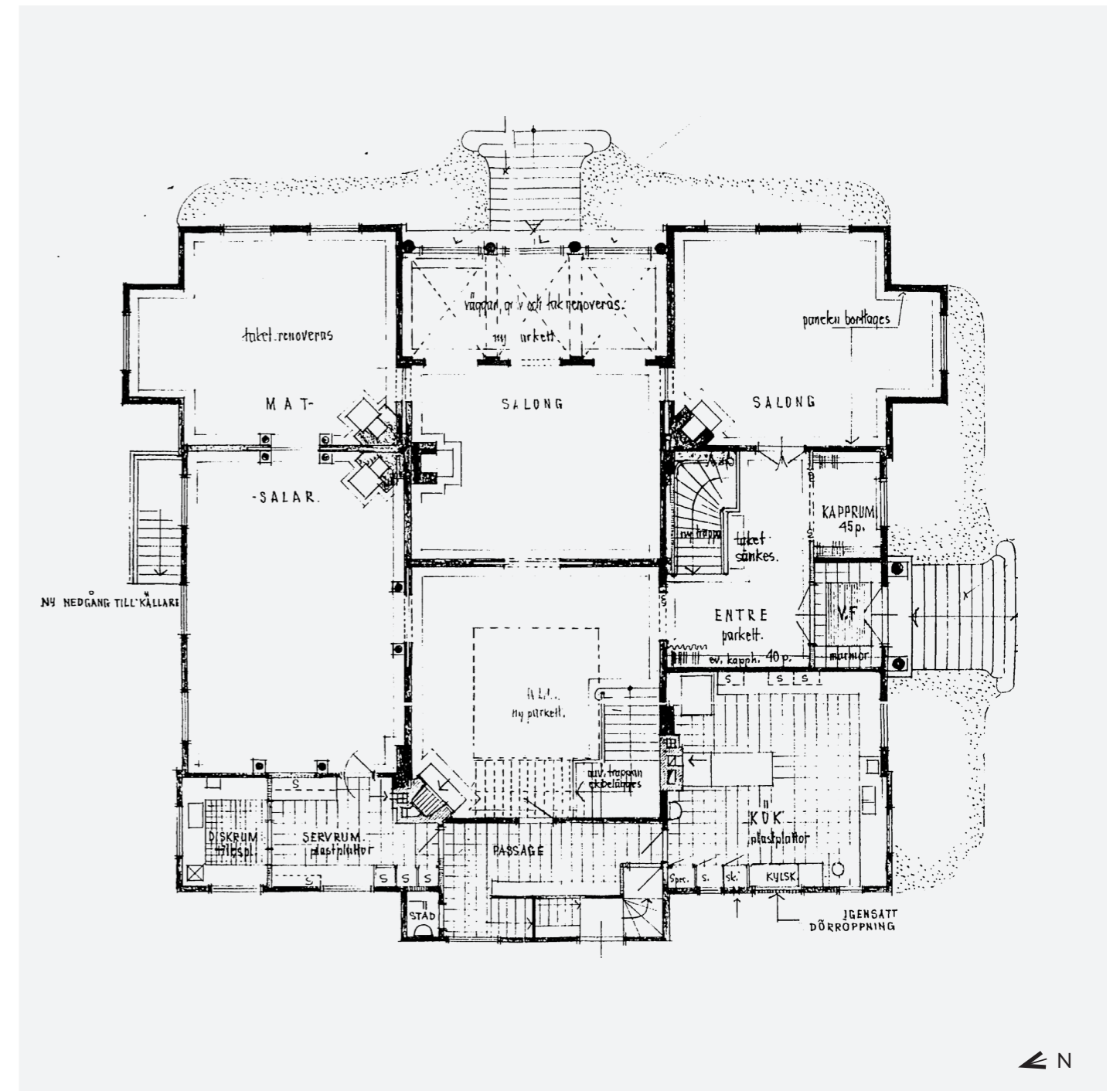

Fig. 7 / Slottsviken entrance floor plan drawing. (Unknown, 1952). CC PDM. 0 5 m

bought by SKF and renovated to become a conference and event venue for the company, which is what it is still used for. (Ackerhans, 2023; *Slottsviken*, 2023)

The property is closed off from the public with a black iron gate, and due to the dense vegetation around it, the villa is only to be seen from

opposite the lake next to it. At the time of writing this thesis, there are not even any free publicly available photos from inside this extravagant historical building, and its Google page is filled with reviews from people who are disappointed that it is not open to the public, making it apparent that people would want to visit if they had the chance.



Fig. 8 / Okänt sällskap vid Labbera. (Malmberg, n.d.). CC PDM. Edited by author.

The Labbera Ruin

When walking in the woods of the nature reserve of Rådasjön, you might encounter the Labbera ruin. The layout of the stones suggests that the ruin was once a church. There is a fallen archway, and next to it lies a rock with a Latin inscription: "sie redit in nihilum quod fuit ante nihil". It roughly translates to: "so returns to

nothingness, what was nothingness before."

There is something peculiar with this ruin. If you were to define "ruin" as a fragment of a decayed or abandoned facility, the Labbera ruin is not really a ruin at all (...or maybe it is now, or will be). In fact, the so-called ruin has never been a church or had any other functional properties

– it has never been anything but a "ruin". It is a staged ruin, a folly.

Generally, "folly" refers to a building with a primarily decorative purpose. Follies experienced a particular surge in popularity in the 17th and 18th centuries. As many manors during this era already featured romantic ruins of monastic houses, some of those who lacked these kinds of historical remnants decided to have it staged. (Folly, 2024)

A sign located in the area tells us that the Labbera ruin was built in the 1830's in order to enhance the romanticism of nature. Martina von Schwerin (daughter of Martin Törngren, director of Ostindiska kompaniet) was the one who had the folly built, after inheriting the nearby estate of Råda Säteri. It is said she considered the property to lack in cultural-historical value – and the folly was supposed to make up for that.

//

Reflection

I came across this site last summer while taking a stroll on the peninsula, spotting Slottsviken across the lake. Although I could not make out the details at that distance, it was obviously a quite extravagant piece. Becoming curious as to what I was looking at, I made a quick Google search. A sense of disappointment washed over me as I realised I was never going to be able to see the building at any closer range than I was at this moment.

As I was searching for a site for this project, I recollected this memory, and realised what I was going to do: use a (mis)interpretation of the plan drawing of Slottsviken in order to make a non-conventional, distorted copy of it – mirrored across the lake. A community centre inviting people in, rather than closing them off. This allows for people to interact with Slottsviken in an alternative way, opening up for an experience beyond merely visiting the original building or a typical reconstruction.

The presence of the Labbera ruin strengthens the project's connection to the site. In different ways, both the folly and the project itself tell stories of what could have been.

Part Four

Process

* This part explores different representative tactics of working with the (mis)interpretation of the entrance plan drawing of Slottsviken, rather than showing a linear process towards the final result.

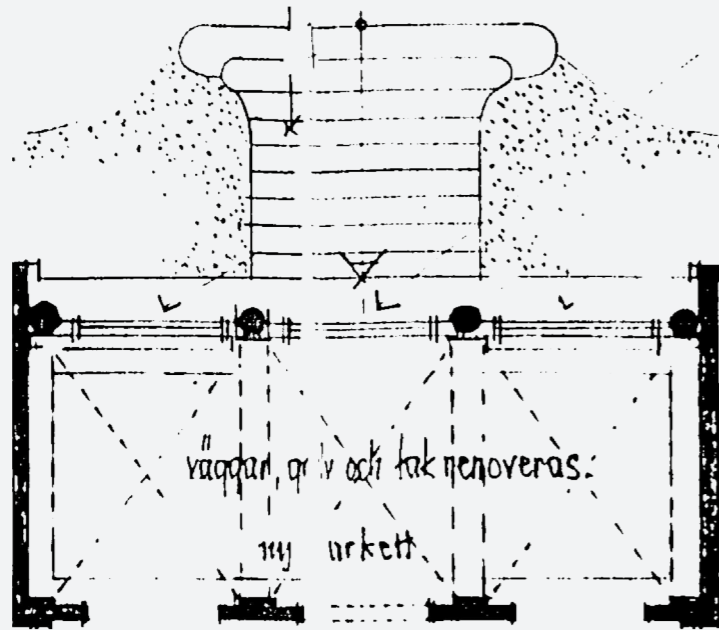

Plan drawing / east entrance of Slottsviken

0 2 m

Vectorising the Drawing

Categorising Components

To get started with the translation from analog to vector, the drawing is dissected into its different components. Shown in detail on this page is a section of the drawing, the east entrance, which is chosen to represent the entirety of the drawing because of its variation. The components it is built out of are perceived as: continuous lines, dashed lines, fills, letters, arrows,

and texture. There is not always an unambiguous answer to what category a component should belong in.

How the different components can be interpreted in 3D is explored further after the translation of the drawing to vector has been made.

Line Types

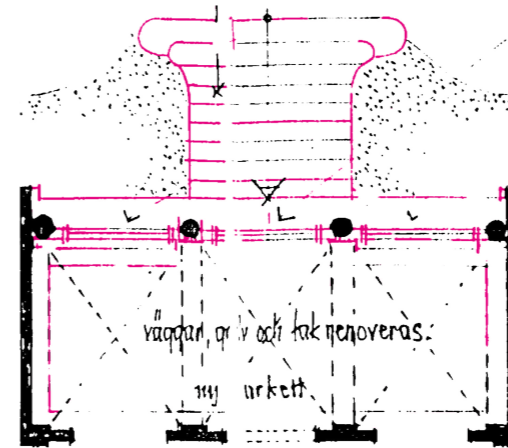

continuous lines

Other Symbols

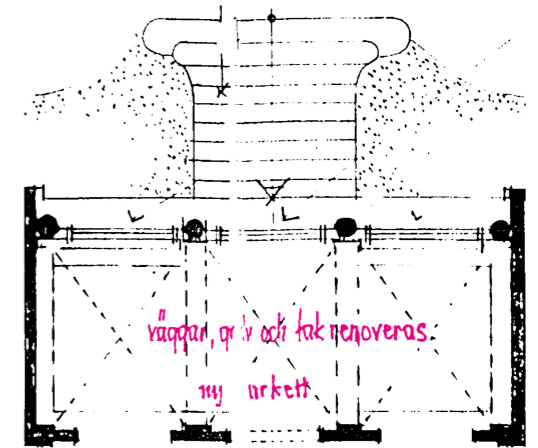

letters

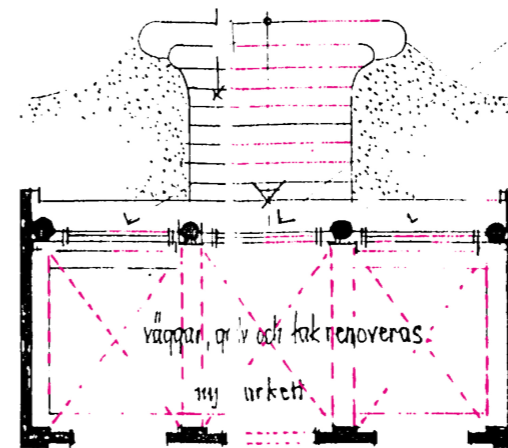

dashed lines

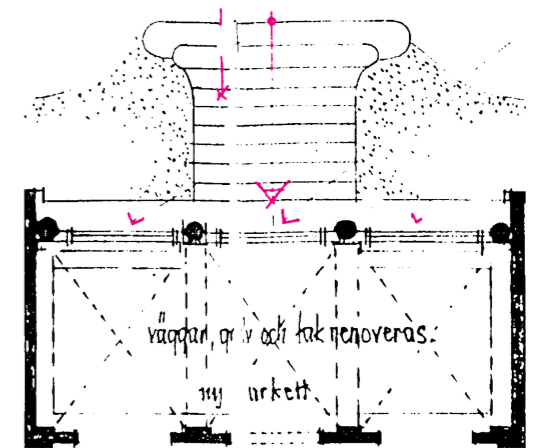

arrows

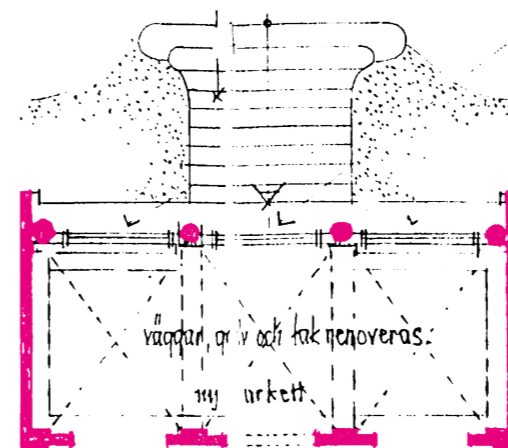

bold lines / fills

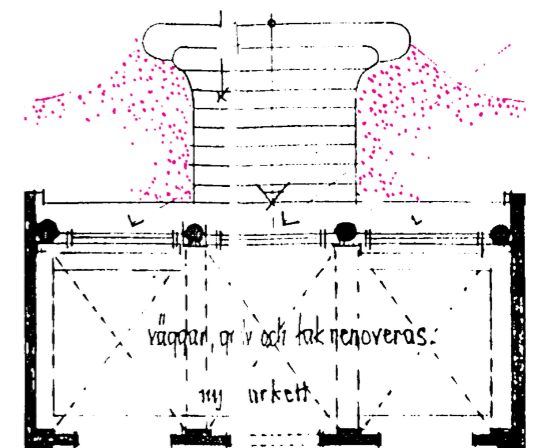

texture

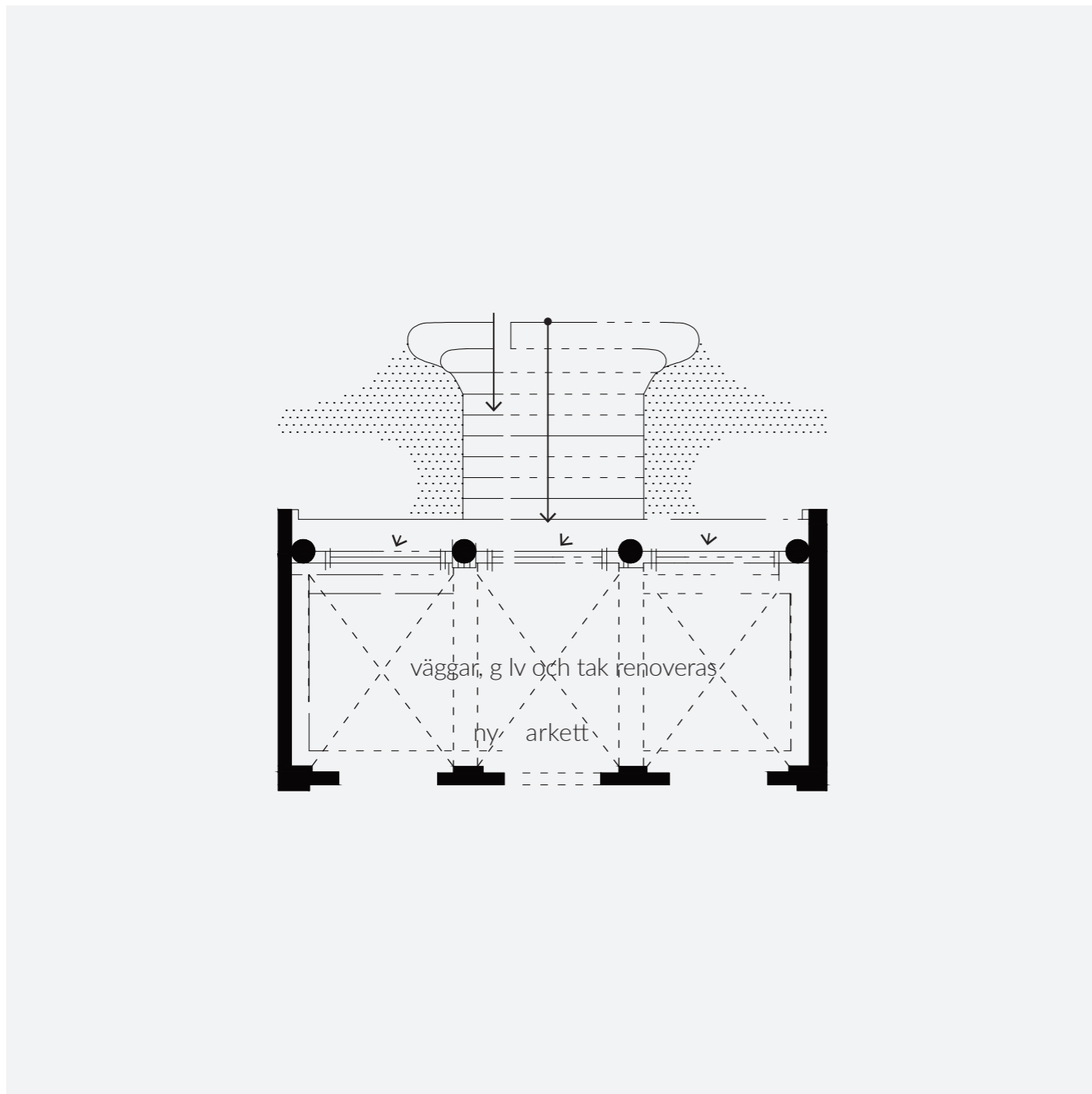

Plan drawing / part of manually translated plan (by author)

0 2 m

Manual Translation

Wickstead (2008) writes about archeological drawings and how after archeologists excavate their sites, they excavate their drawings of them, and gain knowledge about the drawings through the making of new drawings.

The manual translation of the drawing is dependent on the component categories shown

on the previous page – but the categories are also updated throughout during the making of this translation, since knowledge is gained through manually drawing the drawing.

Although the original hand made drawing barely has a single entirely straight line, when manually translating the drawing, wobbly lines can be

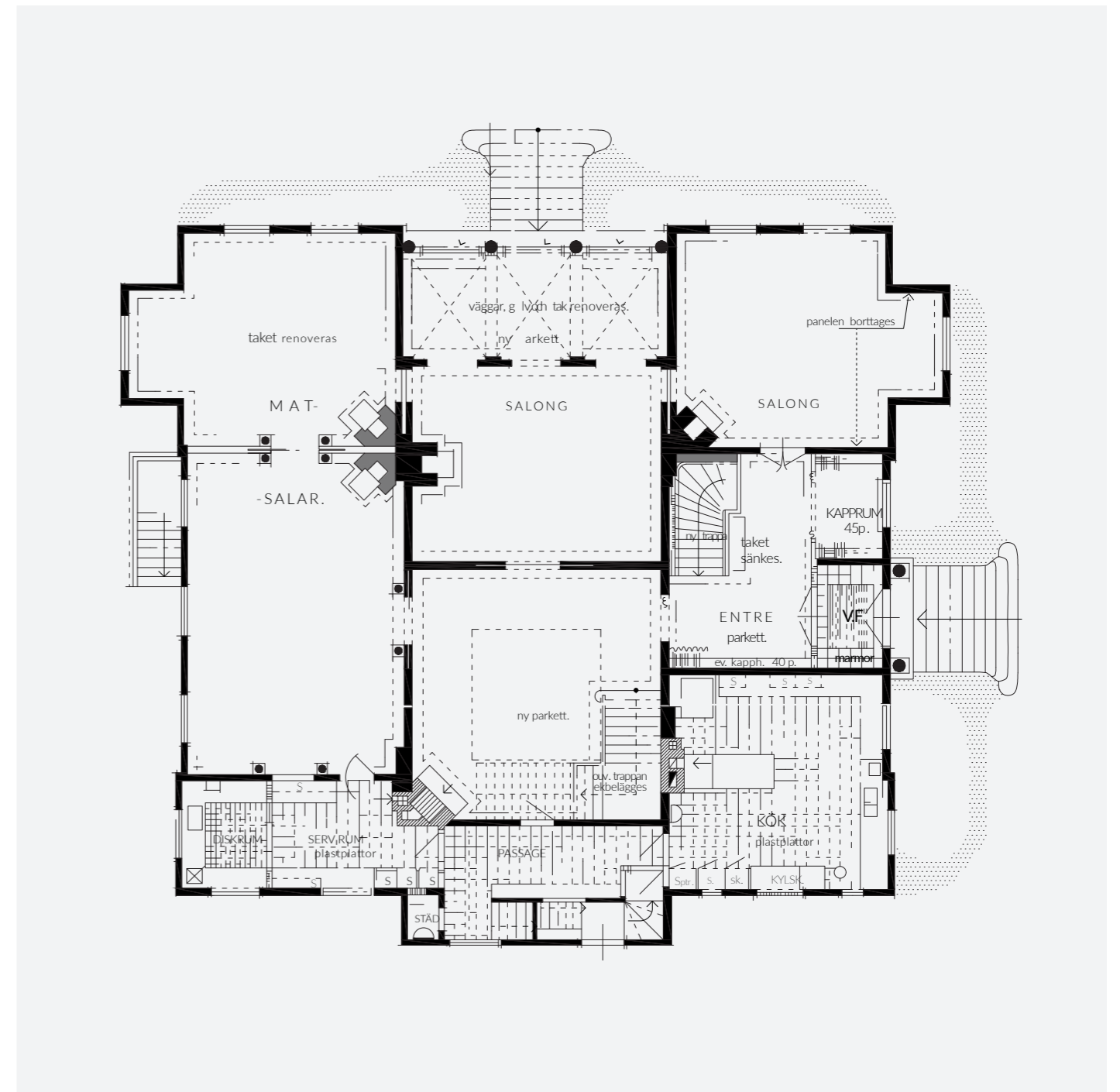

Plan drawing / plan manually translated to vector (by author)

0 5 m

interpreted as having the intention to be straight, and be translated as such. In addition, this translation is made in AutoCAD, where it requires less steps to make a straight line than a curved line, and it would be incredibly time consuming to manually trace non-straight lines.

This translation also deviates from the original in

the "fills"-category as all fills are completely solid, and some symbols are changed to symbols which carry the same perceived meaning. For example, letters in a different font.

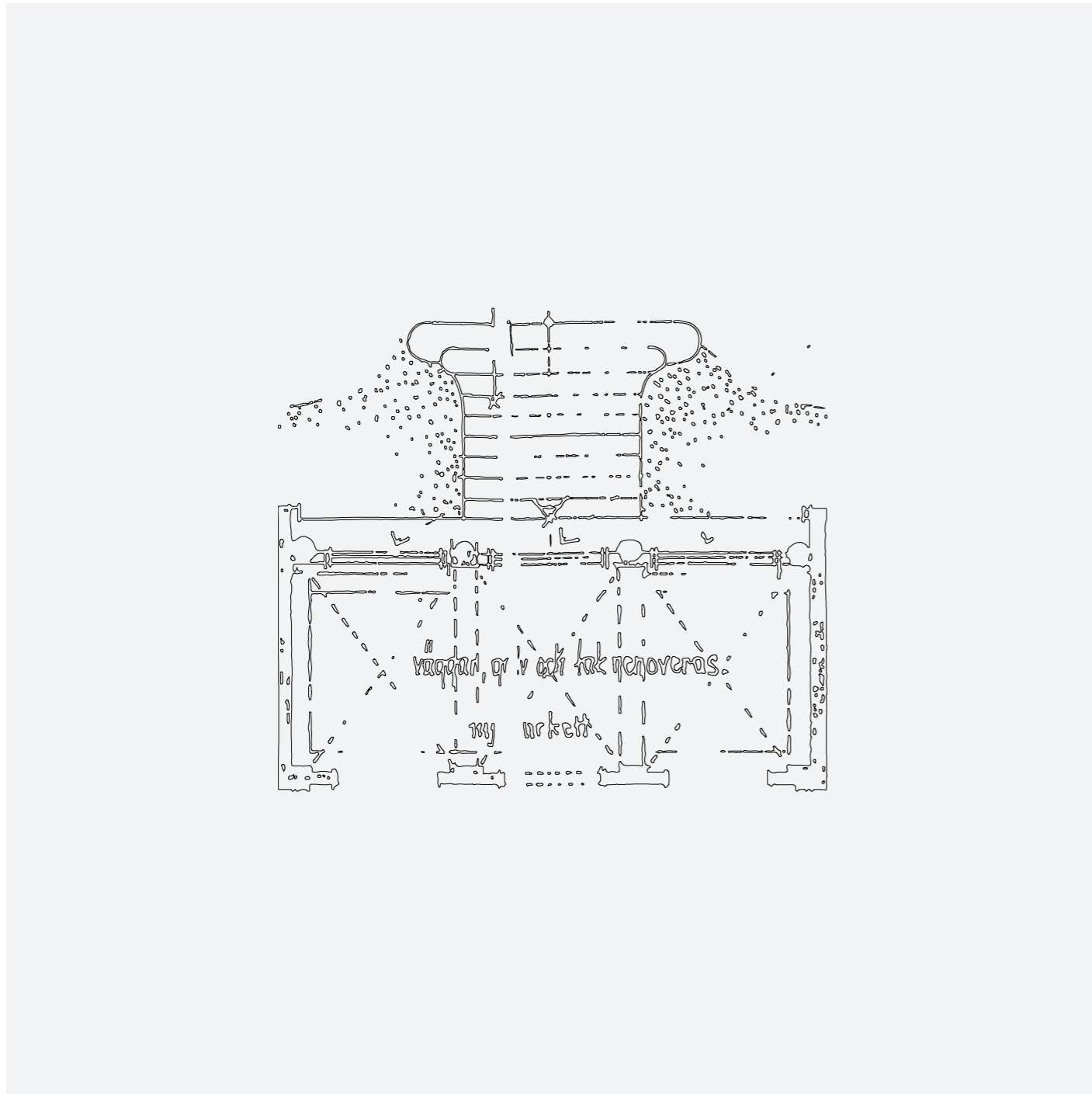

Plan drawing / part of computer traced plan (by author)

0 2 m

Automated Trace

When translating the drawing by automated tracing, the categories from the beginning of the chapter are disregarded. It does not differ between a line and a fill; it translates everything as if it were a fill, and lines are just thinner fills.

In the sense that this translation is but a trace, it does stay true to the original drawing, as curves

and wobbles are accurately reproduced in vector form. Symbols down to letter fonts essentially stay the same. But sharp edges and corners appear softer in this translation.

However, the computer trace is quite literal in its translation, and lacks the ability to interpret intention. Comparing the computer translation to

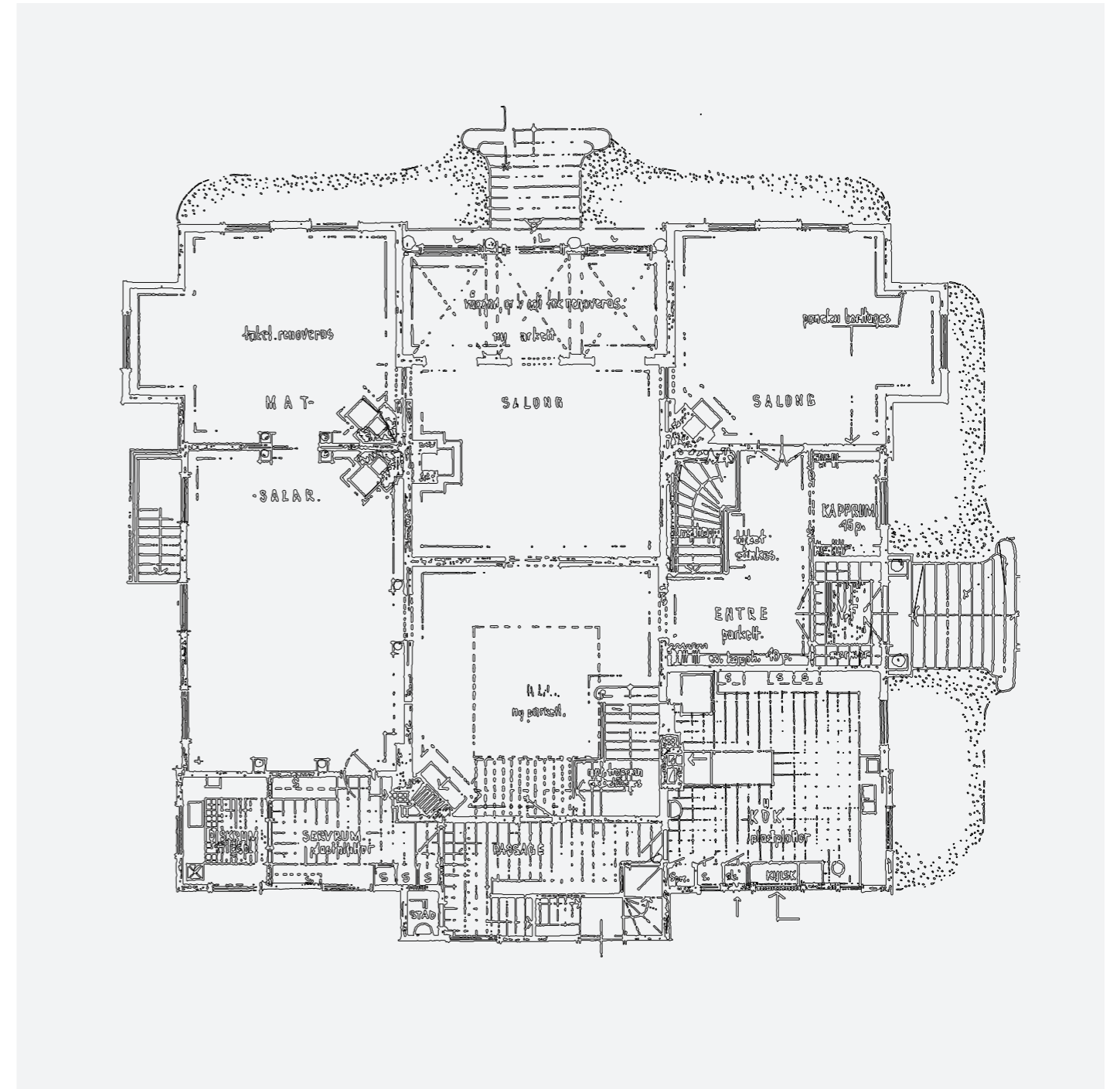

Plan drawing / plan computer traced to vector (by author)

0 5 m

the translation of language, the computer trace is like translating a sentence word by word, without adjusting for the grammarly differences of the languages you are translating between.

This opens up for an interpretation where the medium and tools used to create the original drawing carry a lot of weight.

Documentation of Process

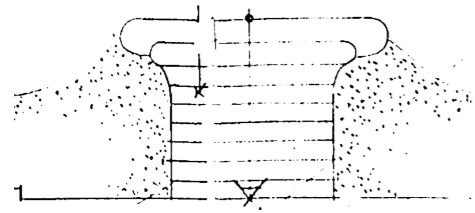

01.

P: Analog
A: original drawing
O: scan to .pdf

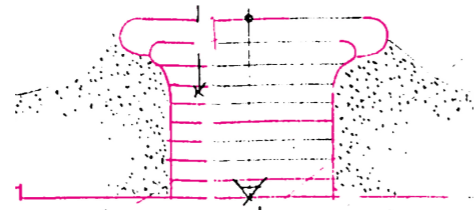

02.

P: Photoshop
A: colour continuous lines
O: save as .pdf

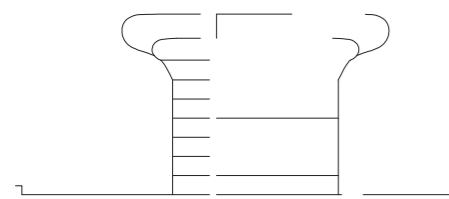

03.

P: AutoCad
A: manually translate to vector
O: save as .dwg

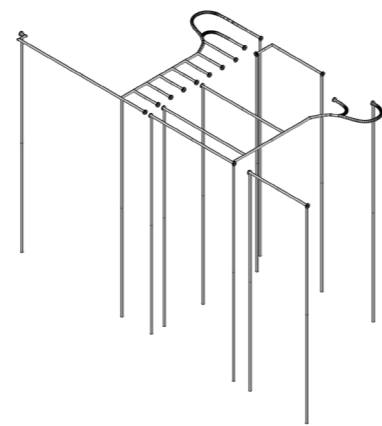

04.

P: Rhino
A: make circle, sweep 1 rail (lines), make cylinder as caps

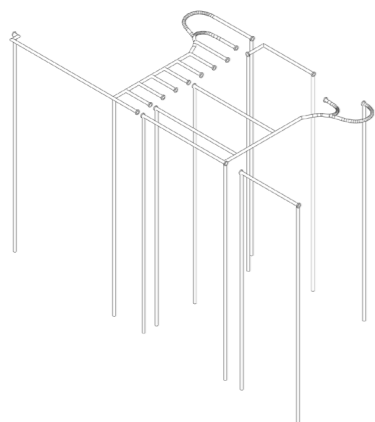

05.

P: Rhino
A: make2D
O: export as .dwg

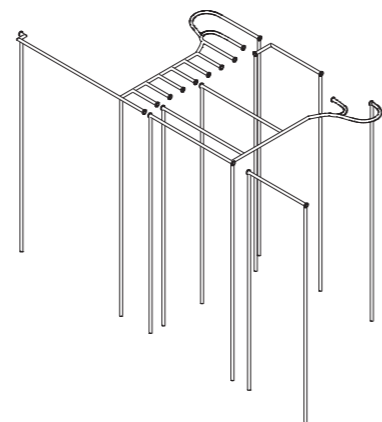

06.

P: AutoCad
A: trim excess lines
O: print as .pdf

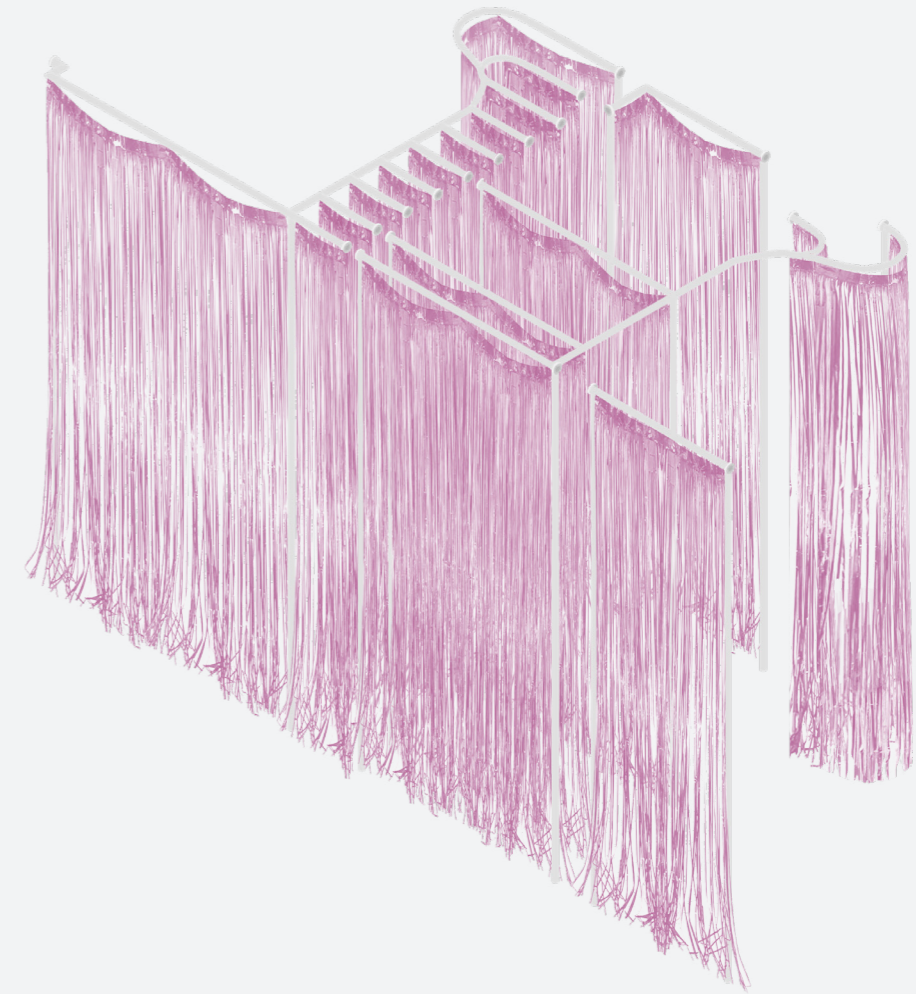

07.

P: Photoshop
A: texturise
O: save as .pdf

Isonometry / open curves representing physical matter / a glitter curtain (by author)

Open Curves

Open Curves as Physical Matter

When manually translating the original drawing, many curves turn out to be open, as in that they do not enclose a surface.

One strategy to deal with this, is to see the lines not as edges but as representing physical matter in themselves.

In this example, it is interpreted that the thin lines represent a thin material. The arrows on the drawing, going through the open curves, could be understood as arrows marking an entrance. The glitter curtain is transparent and inviting, allowed to be entered through at any point.

Documentation of Process

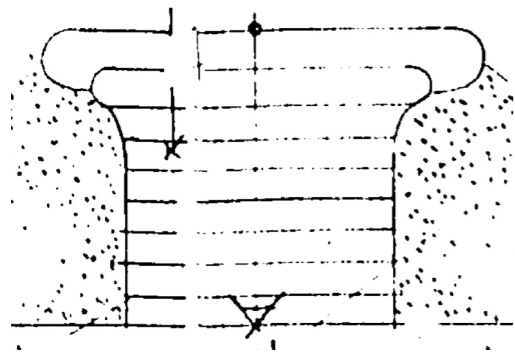

01. **P:** Analog
A: original drawing
O: scan to .pdf

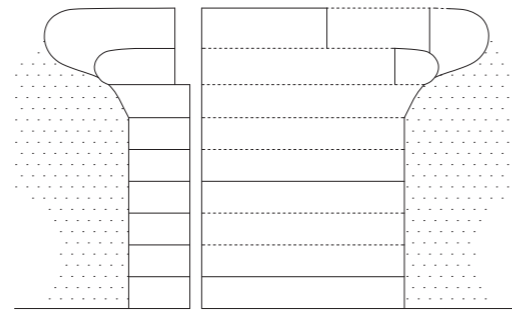

02. **P:** AutoCad
A: manually translate to vector, close the curves
O: save as .dwg

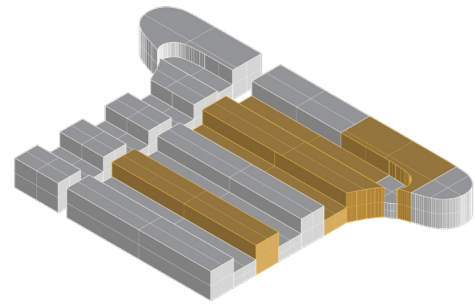

03. **P:** Rhino
A: planarSrf, extrude srf as wanted

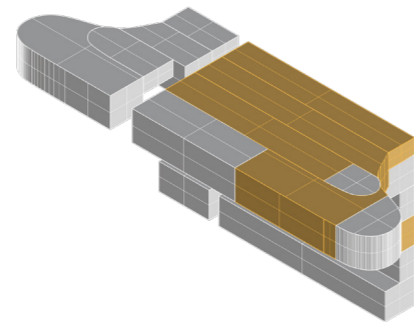

04. **P:** Rhino
A: rotate (according to arrows)

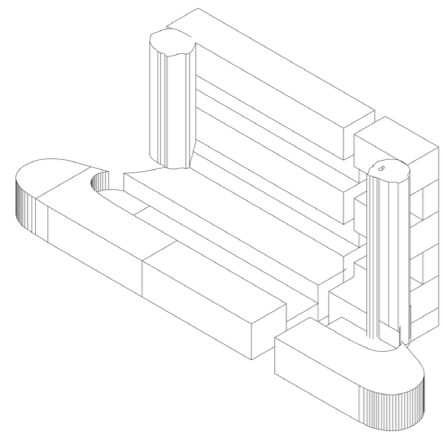

05. **P:** Rhino
A: make2D
O: export as .dwg

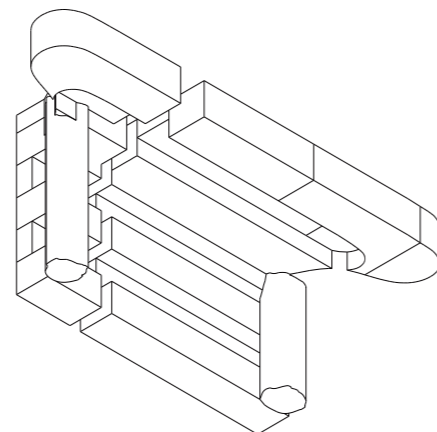

06. **P:** AutoCad
A: trim excess lines, rotate
O: print as .pdf

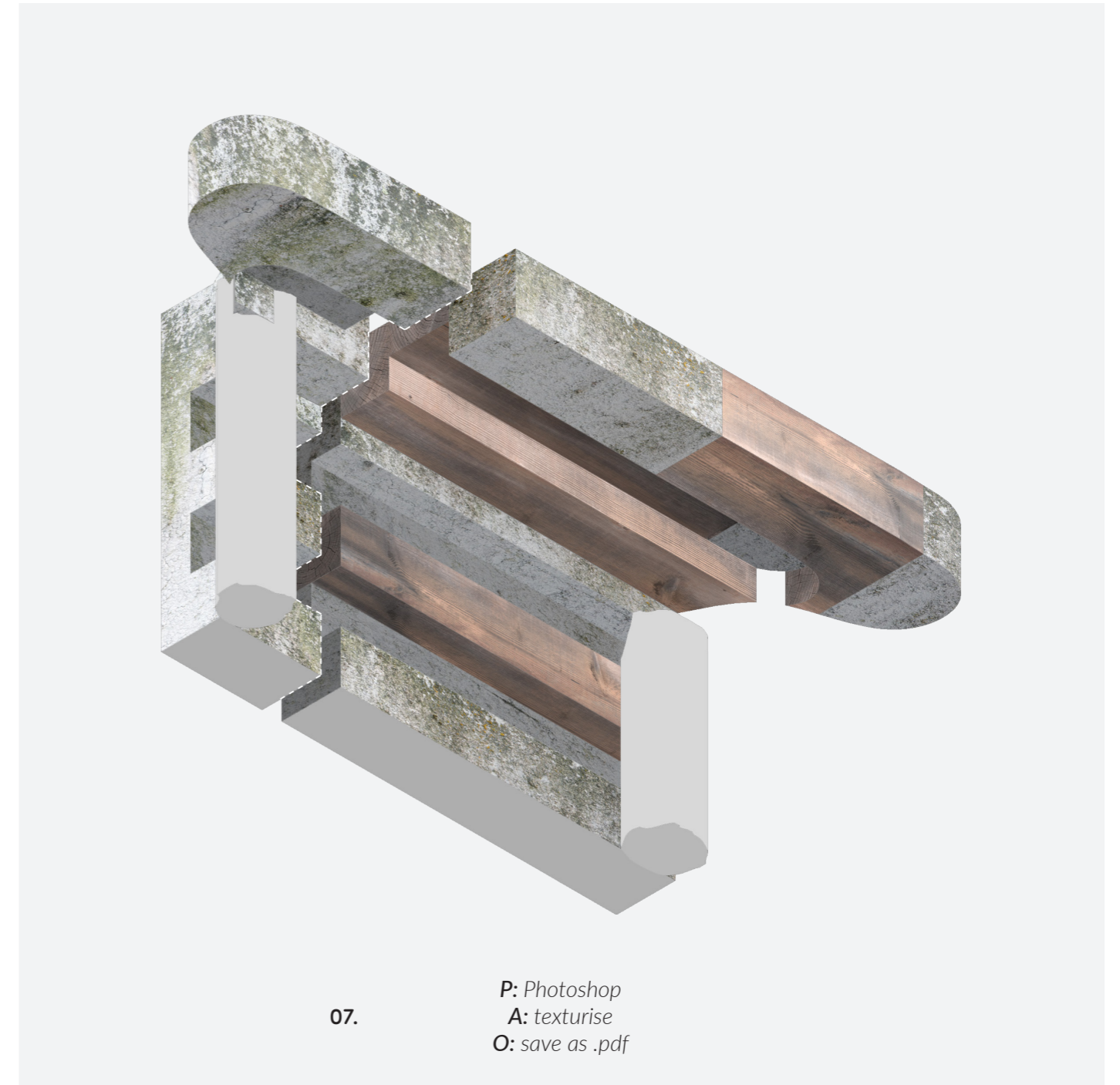

07. **P:** Photoshop
A: texturise
O: save as .pdf

Isonometry / looking up from below / closed curves marking edges / a concrete and wood object (by author)

Closing the Curves

Another strategy of dealing with open curves is to close them. This makes an adjustment to the translation, argued for by the perception that thin lines on a drawing should mark edges of surfaces, assuming that the now reconstructed lines must have been lost from the original drawing.

In this interpretation, the continuous lines mark the object's edges, and dashed lines mark the border of materials (concrete and wood are chosen as appropriate materials). The arrows are interpreted as symbols for folding, in which the object folds twice in on itself.

Documentation of Process

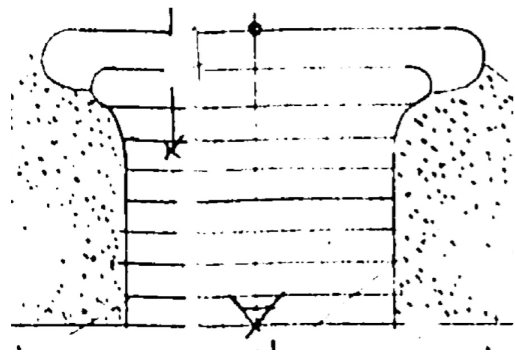

01. **P:** Analog
A: original drawing
O: scan to .pdf

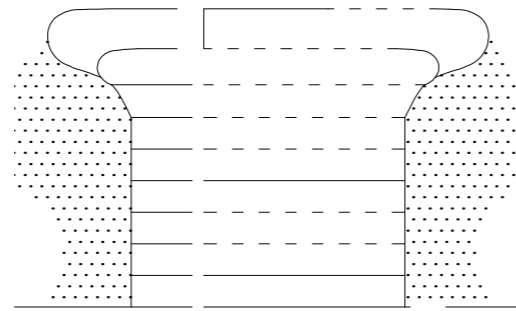

02. **P:** AutoCad
A: manually translate lines to vector
O: save as .dwg

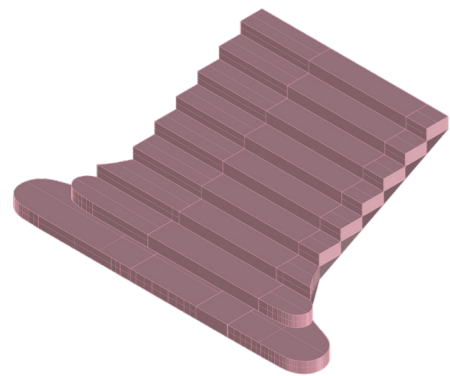

03. **P:** Rhino
A: build a 3D-base according to your interpretation of the original drawing

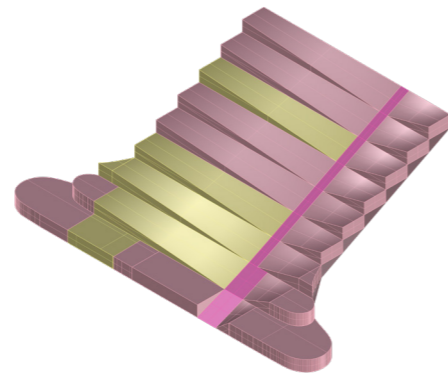

04. **P:** Rhino
A: make adjustments in accordance with the translated open curves

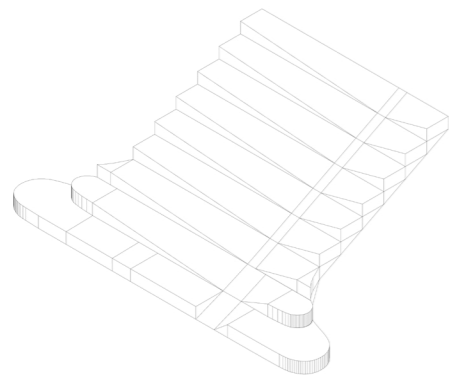

05. **P:** Rhino
A: make2D
O: export as .dwg

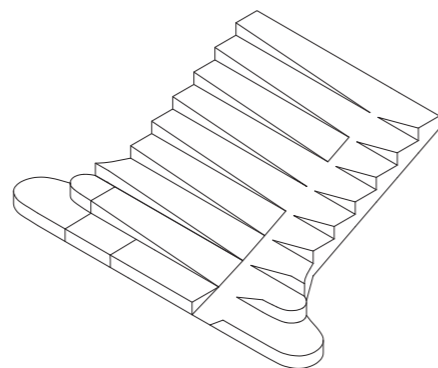

06. **P:** AutoCad
A: trim excess lines
O: print as .pdf



07. **P:** Photoshop
A: texturise
O: save as .pdf

Isonometry / open curves marks the edges of a surfaces / a weird staircase (by author)

Working With the Open Curves

One last strategy of dealing with open curves is to assume that they do in fact mark the edges of surfaces, and where the curves are open, there is no edge. This approach remains faithful to the lines from the translation.

edges of surfaces, while continuous lines mark change in material. In this version, the arrows are interpreted as symbols for a staircase.

In similarity to the previous interpretation, continuous lines are here interpreted as marking the

Documentation of Process

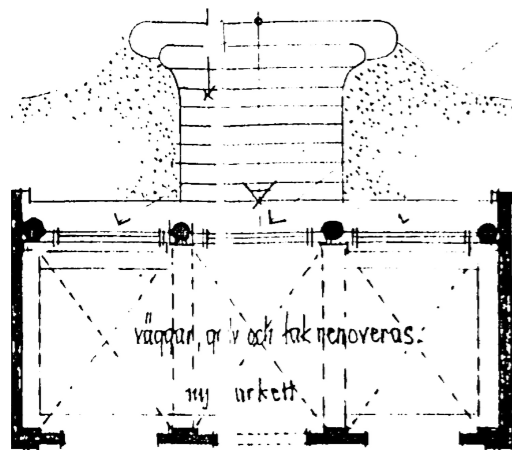

01. P: Analog
A: original drawing
O: scan to .pdf

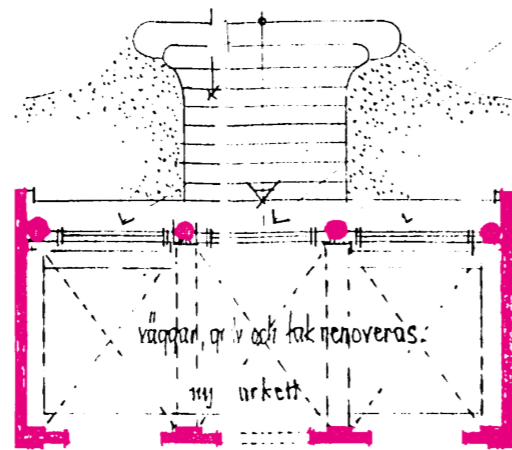

02. P: Photoshop
A: colour fills
O: export as .png

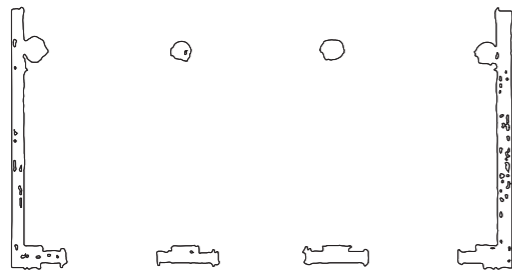

03. P: Illustrator
A: trace, delete excess, invert line and fill
O: export as .dwg

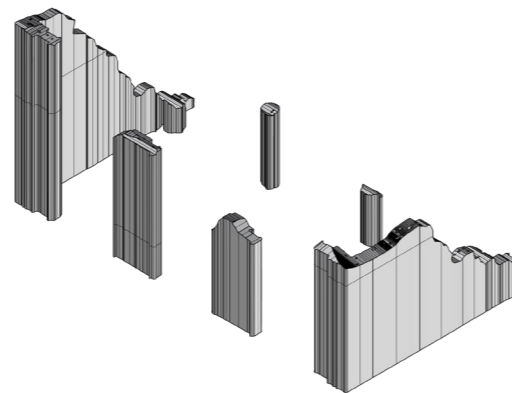

04. P: Rhino
A: planarSrf, extrude srf 2,6m, sculpt with booleanSplit

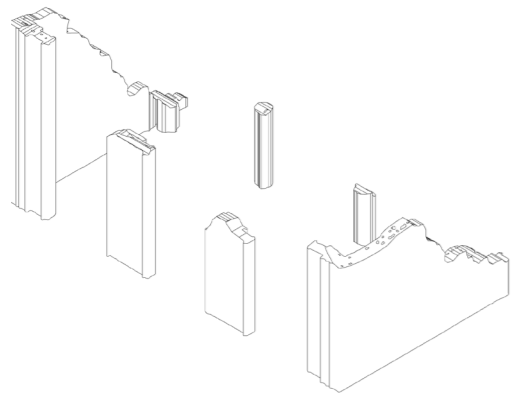

05. P: Rhino
A: make2D
O: export as .dwg

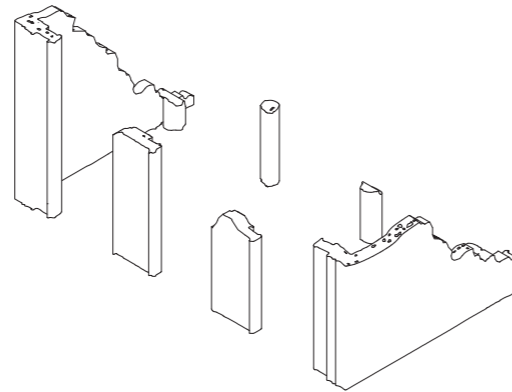

06. P: AutoCad
A: trim excess lines
O: print as .pdf



07. P: Photoshop
A: texturise
O: save as .pdf

Isonometry / traced fills with "holes" in the solid / a concrete ruin (by author)

The Automatically Traced

Fills

When dealing with fills based on the computer traced translation, they are closed curves, and can be interpreted in similar ways as to what you could assume the original intention was, although having a softer expression. But they are also not completely solid, as the closed curves have other closed curves inside their area.

It is interpreted that the closed curves from the fills represent a thick material, but something a little bit porous or broken, that can be molded into a specific shape. Perhaps concrete which has aged and been damaged, causing holes in the solid.

Documentation of Process

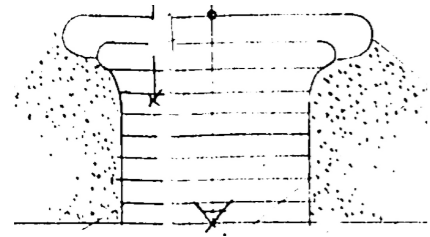

01.

P: Analog
A: original drawing
O: scan to .pdf

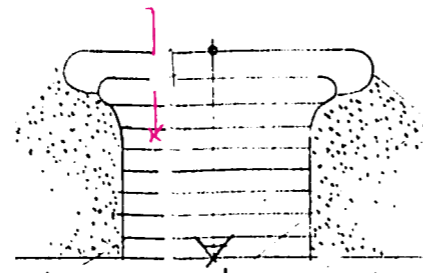

02.

P: Photoshop
A: colour wanted lines
O: export as .png



03.

P: Illustrator
A: trace, delete excess, invert line and fill
O: export as .dwg

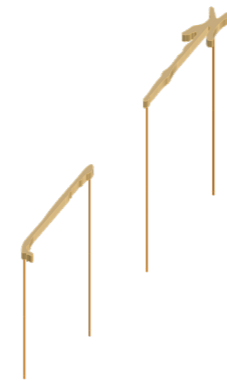

04.

P: Rhino
A: planarSrf, extrude srf, sculpt with booleanSplit, add support
O: export as .obj

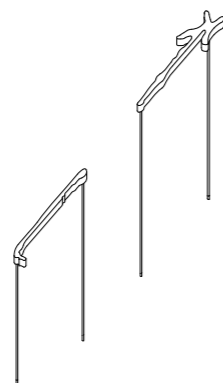

05.

P: Rhino
A: make2D
O: export as .pdf

06.

P: Photoshop
A: colour
O: save as .pdf



Isonometry / traced line making a surface / a metal railing (by author)

Lines

As previously mentioned, the traced translation does not differ between fills and single lines.

In this example, the lines forming an arrow are translated into a closed curve encapsulating a surface. This is then interpreted as matter, rather than a non-physical symbol.

If the lines around are interpreted as a staircase, such as in the example under "Working With the Open Curves", the traced arrow could work as a railing for said staircase. It could for example be made out of metal, cut with a water jet to contain the specific traced shape.

Part Five

Proposed Interpretation

Perspective /
exterior / facade
facing Rådasjön
(by author)



Fig. 6 /
Slottsviken.
(Oberger,
2014). CC
BY-SA.
Edited by
author.

The Exterior

The Original and the Copy

Slottsviken and the community centre are facing each other from opposite sides of Rådasjön. Made from translations of the same plan drawing, the community centre is a copy of the original (Slottsviken).

Here, the facade is a function of the plan, and as we cannot tell the appearance of a building

based on just a plan drawing, the buildings do not look the same. The copy is distorted.

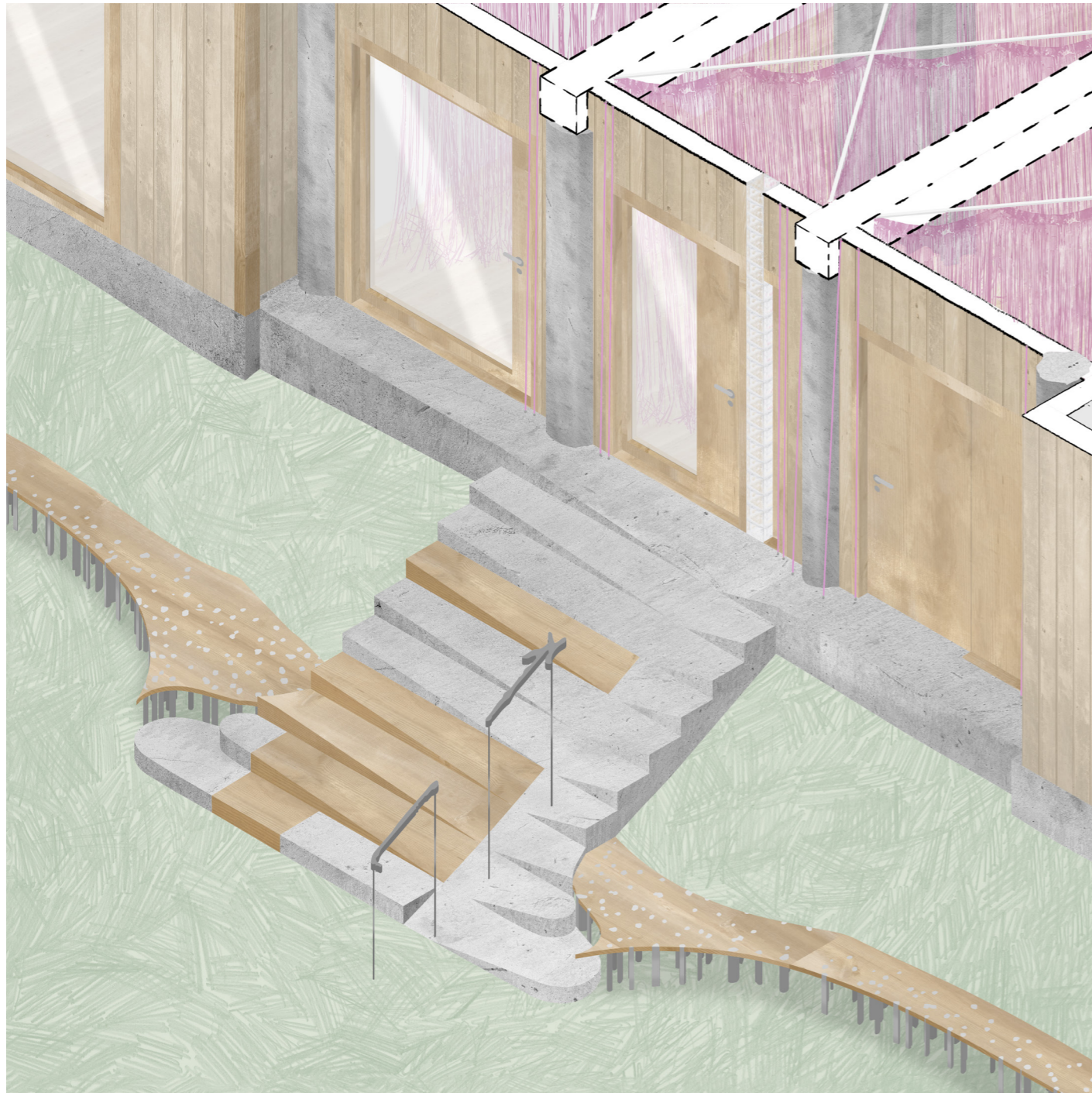

Isonometry / main entrance (by author)

The Entrance

Visitors first come in contact with the building via the entrance staircase. With its leaning steps and seemingly odd transitions of materials, it communicates to the visitor that this is not an ordinary building, intending to awaken curiosity.

Next to the staircase, surrounding half the building, is a bench with metal legs interpreted

from the automated trace of the dotted texture in the drawing. The bench signals to the visitor that they are welcome to stay, as opposed to the iron gate shutting people out of Slottsviken.



Isonometry / facade (by author)

Walls

The walls define the limits of the building's spaces, and they are created through extrusion of both the manual translation (interpreted as straight, wooden walls) and the automatically traced translation (interpreted as soft, moulded concrete). The use of both hints to the visitor that there are several interpretations leading to the creation of the design.

The concrete wall reaches above the roof, this is to say that while the spaces have been defined by design, the plan drawing does not limit the walls to any specific height. The curved top flirts with the aesthetics of the ruin, a nod to the ruin of Labbera.

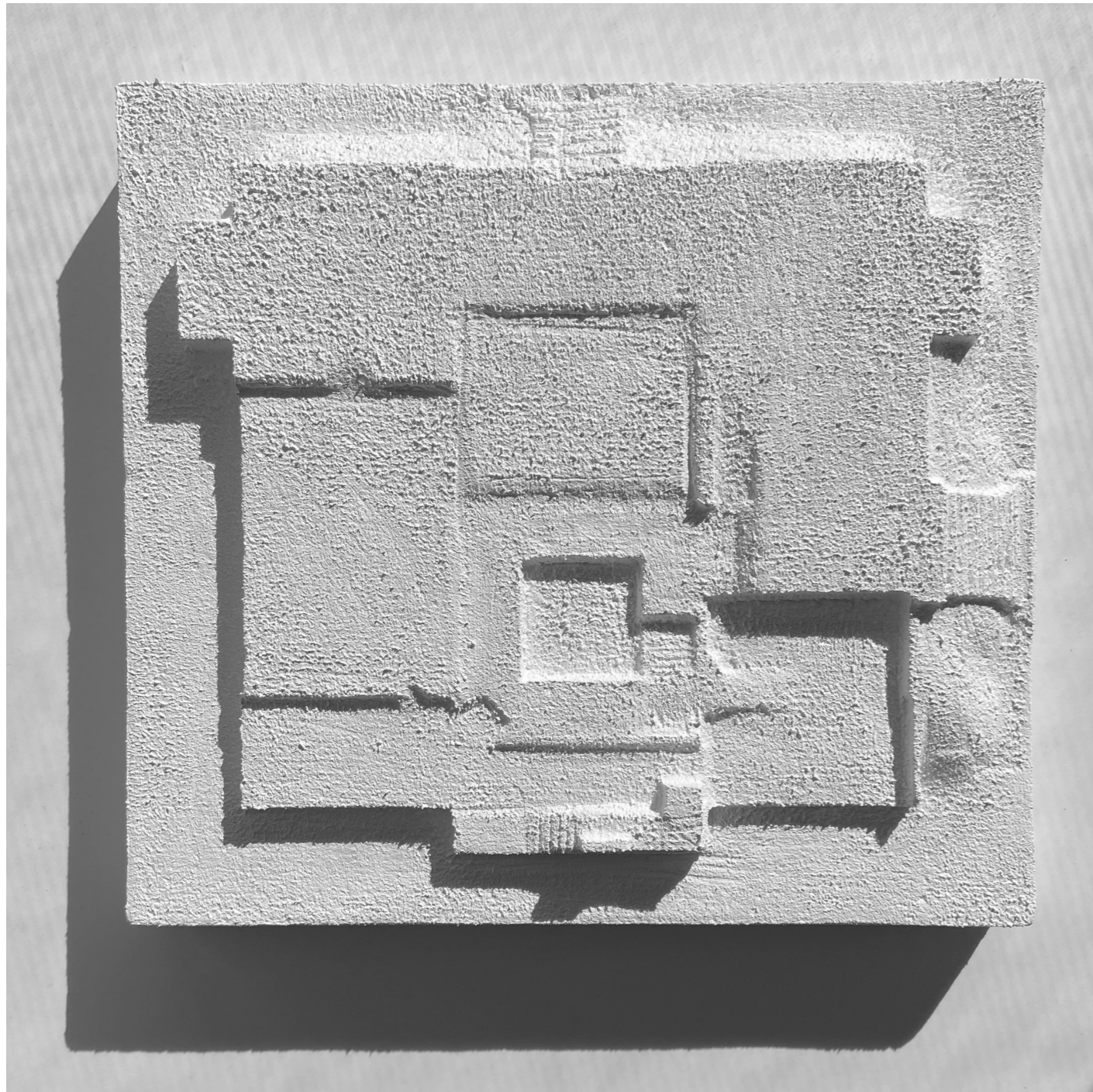

Model / the ground / the space / cnc milled styrofoam painted with white acrylics (by author)

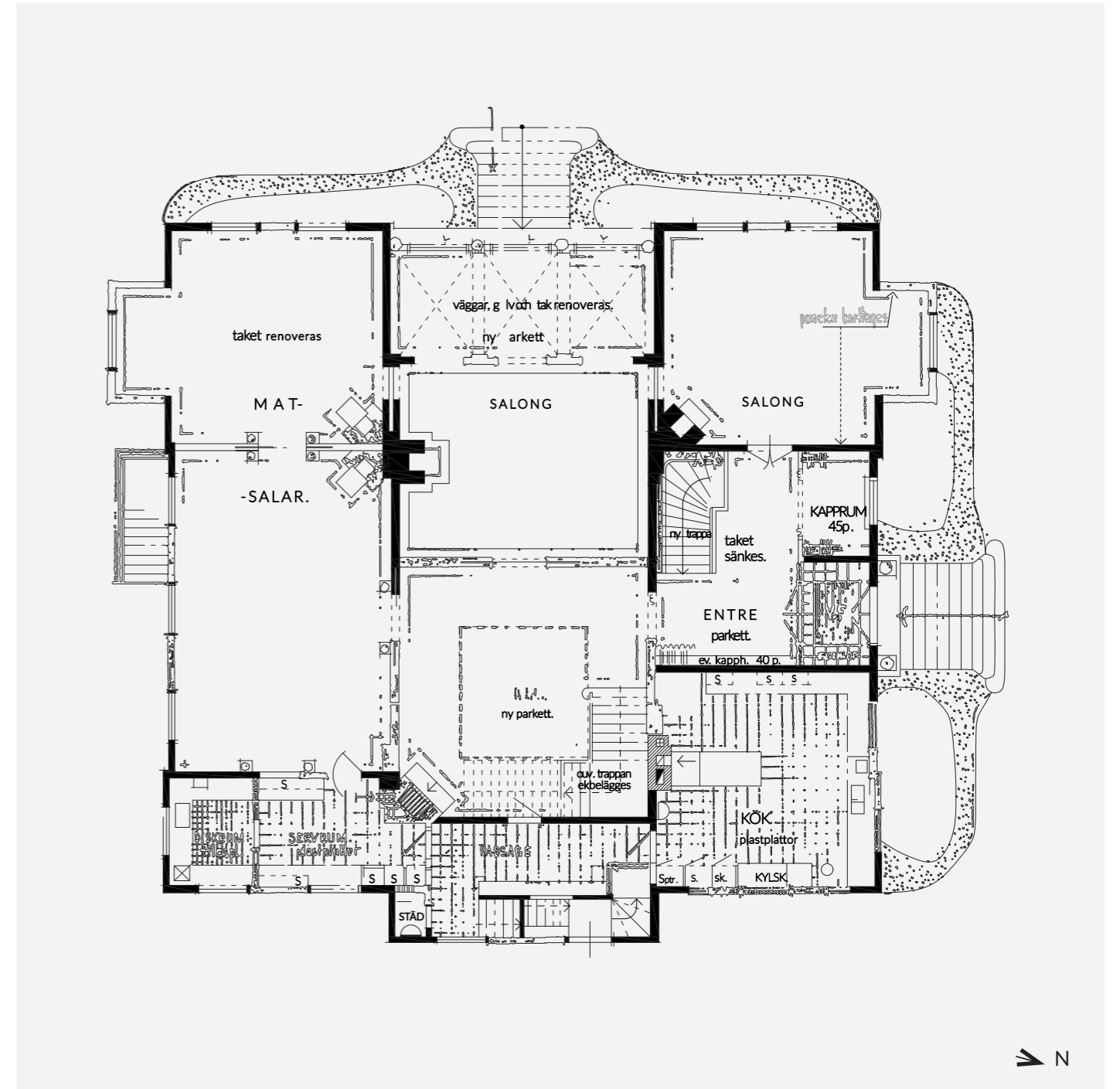
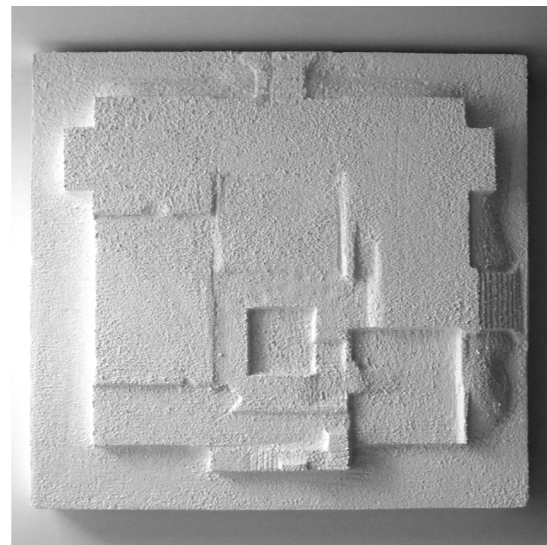
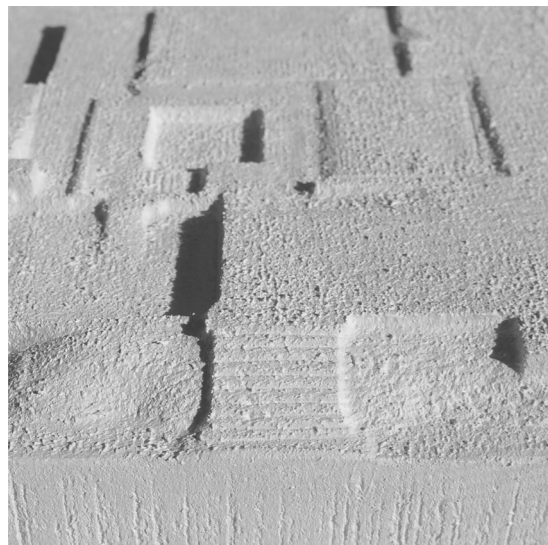

Plan drawing / translated / community centre entrance floor (by author)

0 5 m

The Interior

The Plan Drawing

Pictured above is the final vectorised plan drawing of the community centre, used for the 3D interpretation. It is a merge of the manual translation and the automatically traced translation (see pp. 42-45).

The Ground

The 3D interpretation of the plan begins with interpreting the negative space of the drawing – the part that is blank and completely up for interpretation. This interpretation deals mostly with direction and depth (see p. 22). The negative spaces of the drawing make up the ground and the spaces of the building. In the model, the ground of the community centre is shown.



Perspective / central parlour (by author)

The Central Parlour

The pink glitter curtain is a feature found throughout the building, with the intention to symbolise transparency, creativity, and celebration. At certain points, such as in the central parlour, it has to be walked through in order to reach other spaces. The curtains are created from lines interpreted as physical matter (see p. 47) and the sensation of walking through the curtain serves

as a reminder of the line it was created by.

The central parlour does not border an exterior wall, but takes advantage of the fact that the plan drawing does not disclose wall height – this room reaches above the others, allowing light to seep through windows higher up.

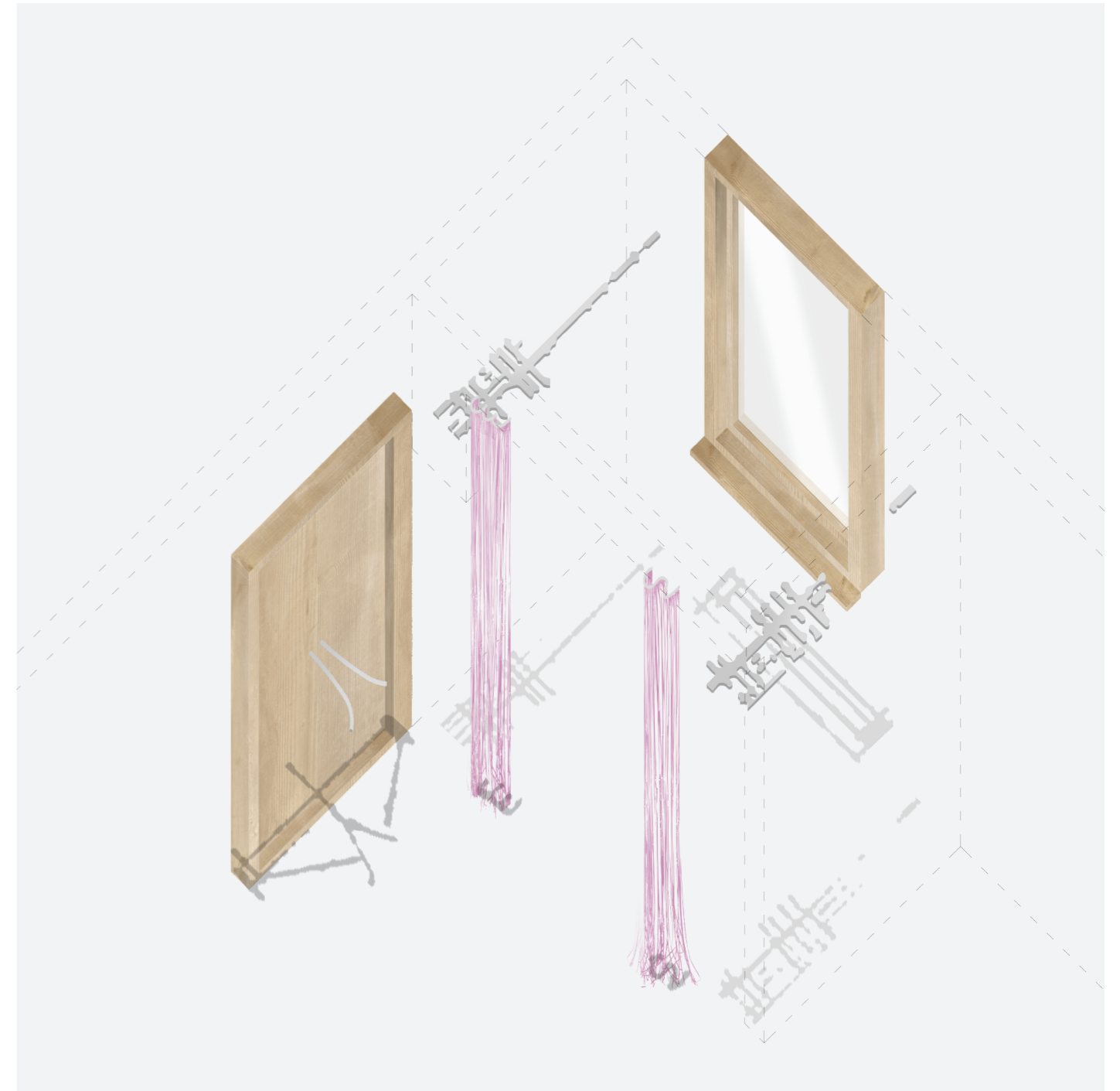

Axonometry / storage / cloak room (by author)

0 1 m

(Mis)interpreted Symbols

The door by the cloak room has a pair of expressive door handles, interpreted from the curves originally representing the arch of the open door.

The clothing racks are still clothing racks, as symbolised on the drawing, but through interpreting them from the automatically traced translation, the lines of the original drawings go

from semi-symbolic symbols to literal symbols – directly shaping the object.

These objects help make the drawing itself readable to a visitor of the building.



Perspective / dining hall (by author)

Transitions Through Lines

When moving between rooms and spaces in the community centre, there is almost always a difference in floor level by at least one step, defined from lines on the drawing interpreted as edges.

Through directing the visitors up and down rather than just straight ahead, the drawing is given power to alter how people move through

the building, making a single line a physical sensation.

The ceilings are lined with skylights based on lines from the automatically traced translation, enhancing the readability of the drawing in the building.

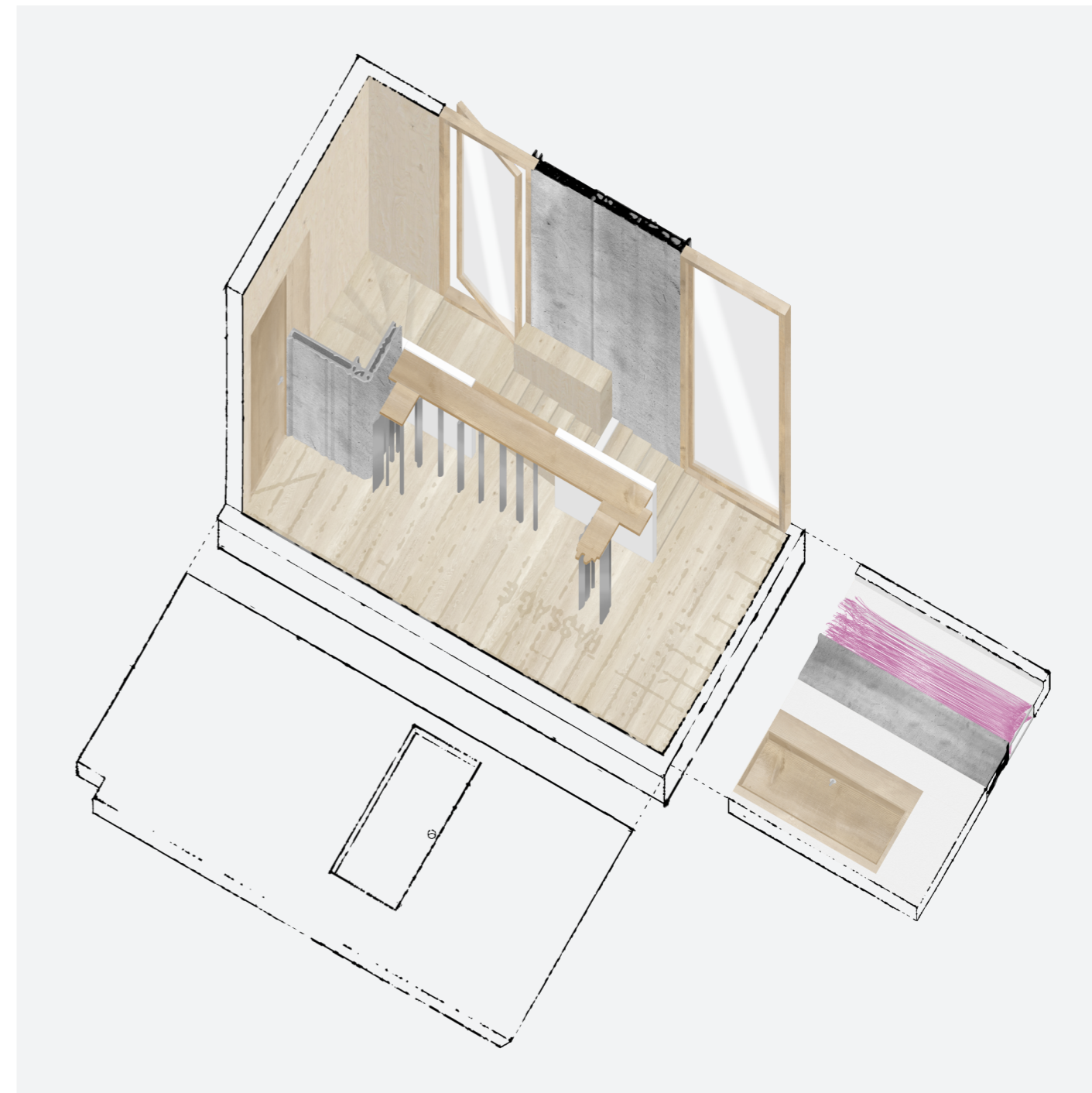

Axonometry / meeting room (by author)

0 2 m

Disorienting Space

In the centre of the meeting room is a built-in table in a slight, asymmetric U-shape. Around half the table, a staircase is wrapped.

The meeting room is disorienting – users of this space will actively have to think about how to orient themselves in it, as there is no predetermined single answer. This could encourage reflec-

tion and conversation in a group, on who sits where and why.



panel removed

panel removed



Discussion and Reflections

Throughout the thesis I have pushed the argument that there are multiple layers of meaning, allowing for different interpretations. This is also true for the thesis itself. While I recognise that there may be more understandings of this thesis than I can account for myself, this chapter focuses on discussing my thoughts from working with the project.

First, a disclaimer: this is not a building. It is a fictional project represented by drawings and illustrations. Having this in mind, I have and will refer to the proposed interpretation as a building, for the sake of simplicity.

Non-Conventional Design

Through translating and (mis)interpreting drawings, new designs can be discovered. The project expression presented is not a result I would have reached had I used a different method. I am able to state that with confidence, since the final project in itself tells us about the process leading there, from drawing to building. Through the parts of the building built out of the automatically traced translation, a visitor would be able to get a glimpse of the original drawing and the tools it was created by. In addition, by contrasting the automatically traced parts with parts from the manual translation, the building hints that there are more interpretations leading to its creation.

The architecture that is designed is not the most conventional, or the most efficient, and it does not have the ambition to be – but it is functional, intriguing, and it tells an alternative story of Slottsviken: one that is transparent and welcoming, rather than concealed and closed off. It invites the visitor to explore different ways of how space can be moved through and used.

Queerness and Disorientation

Drawing on Ahmed's (2006) comparison of queerness and disorientation, as described on p. 14 of this thesis, I hypothesised that disturbing the order of drawing conventions could induce a sense of disorientation in the reader. Indeed, I find that statement to be true for this thesis' method of designing. If I had to use one word to

describe what it has been like to both develop and use this method, it would probably be that – disorienting. However, I believe that feeling has been necessary, as it has challenged me in my understanding of what a drawing is. Additionally, I believe the method to be effective in designing architecture which invites the reader to a more nuanced understanding of drawing. The disorientation of the method is at certain points reflected also in the building, where – again – there is not an obvious single answer to how the space should be moved through and used.

Architecture and Humour

Another aspect of the project is that it is humorous. It is an architectural innuendo of sorts, in the sense that I intentionally misinterpret drawings as if they are implicitly hinting at something other than the conventional. At times when discussing the project with student colleagues and presenting different interpretations, especially when the interpretation is taken far from its original intention, it has provoked laughter. This disorienting view of what a drawing could represent can give you a funny feeling, and the project is light-hearted, although not unserious. But it does highlight and overstress mistakes, such as lines disappearing when the drawing was scanned from analog to digital. Thinking the project is funny is not derogatory but a response to having your perception changed as the drawing gets exaggerated almost in a satirical manner, encouraging reflection on the quirks of the drawing process.

The Future Archeologist

One reading of the project is that I assume the role of a future archeologist, attempting to reconstruct a building based on its plan drawing without any other information about it. This serves a base for a speculative discussion on how our drawings could be interpreted in the future. Here, "information" is a keyword. One could look further into how drawings and their information is stored today – whether in physical formats such as folders or USB sticks or in digital clouds such as social media platforms – and speculate about what information the future archeologist might have access to but especially

about what they will be able to learn about our society and architecture based on this information. But also – what can we learn about me and my habitus, in the role of the future archeologist and subjective interpreter, when we look at how I reconstruct the building based on the plan? My biases inevitably shape my interpretation, and I follow certain conventions while deviating from others. For instance, we learn that I believe a building for a community centre provides shelter from the outside climate, as I interpret walls and roofs even where a different interpretation could be possible, but that I do not believe these walls have to be of one standardised solution.

Drawings as Architecture

Working with this project has allowed me to reflect on what I believe architecture is. I have referred to Evans (1986) and the idea that architecture is the translation from drawing to building. I agree, that is architecture, but perhaps not the only definition of the word. If architecture would only be the translation from drawing to building, then the architect is entirely dependent on construction workers to translate their drawings to make architecture. In this thesis I have worked with the translation and interpretation of drawing, but it has not and will not reach the building state, yet I believe I have designed architecture. I have opened up for the understanding that drawings can be considered architecture, independently.

Beyond Single Drawings

If this project was to be continued, I think it would be interesting to explore how the method of (mis)interpretation could be developed to include multiple drawings (despite having argued for the value in interpreting a drawing on its own): how they inform each other, what still is up for interpretation, what is not. For me, these questions complicate the task of designing using (mis)interpretation, which is why it did not fit in the time frame of this thesis. The facade is now a function of the interpretation of the plan, but the distorted mirror image of Slottsviken would be interesting to explore with the additional use of a facade drawing.

Material

Despite the design being described as non-conventional, most of the materials used in the building are quite conventional (wood, concrete, metal, glass). I can reflect on this from two perspectives.

One is that the project could have been a great opportunity to explore what queerness and interpretation means in terms of material, making an even bigger statement of how drawing gets translated to building.

The other perspective is that through using mostly conventional material, more emphasis is put on the non-conventional forms and material (the pink glitter curtains). The contrast of conventional and non-conventional helps the building from becoming monotone in either direction.

Subjectivity Awareness

On the one hand, an architect reading this project could become encouraged to make their drawings more heavy with information, to enable as little misinterpretation as possible. On the other hand, they could appreciate the drawing for its abstraction and embrace the subjectivity of another interpreter, potentially adding layers of meaning to their project.

My intention with the thesis is not to critique the subjectiveness of drawing, but to urge the reader to be aware of and intentional with their interpretations, and to raise a conversation about future uses of drawing.

Student Background

Julia Forsberg
+46 (0) 70 297 48 46
julia.forsberg.ark@gmail.com
@jarkitektur

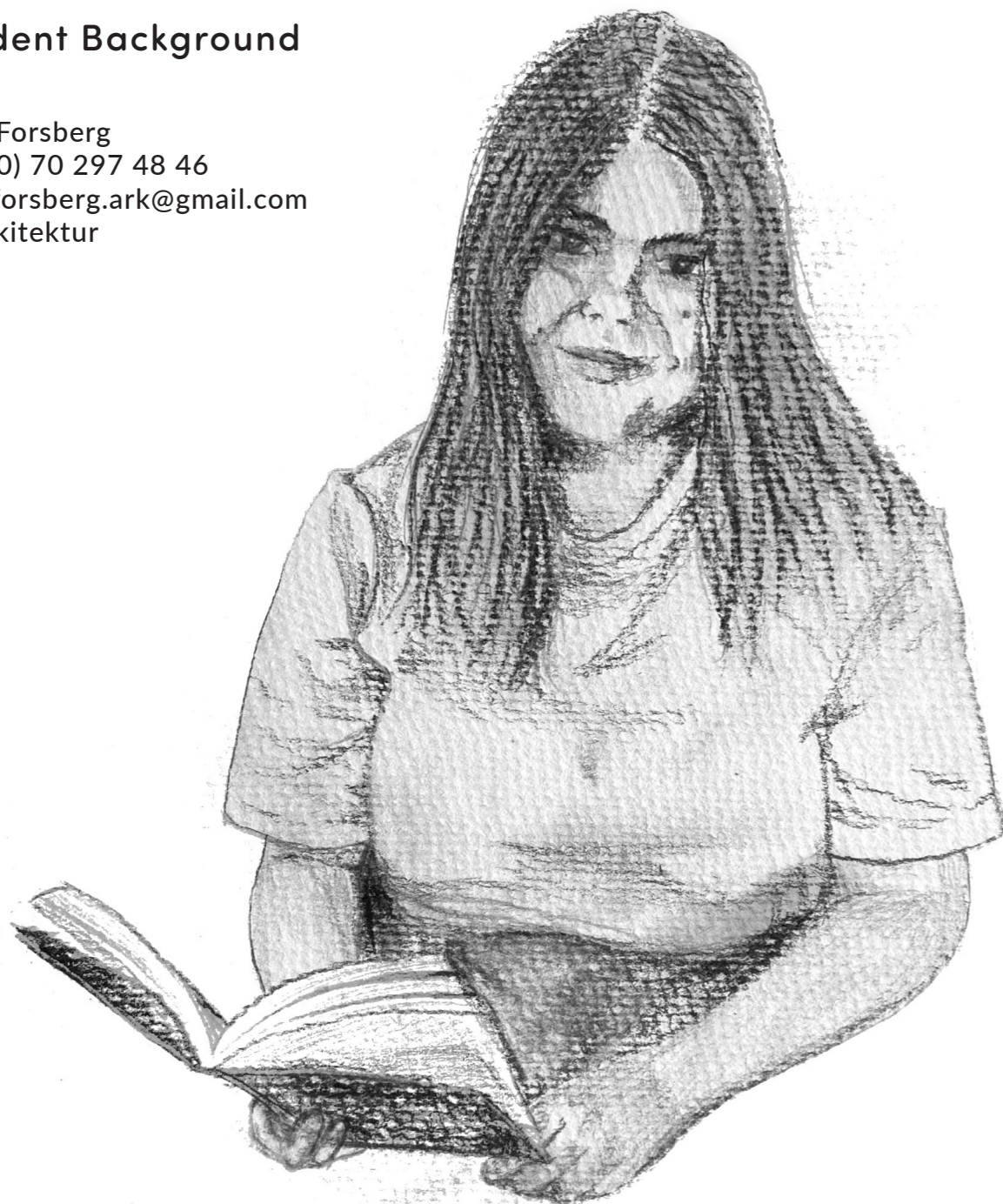

Education

2022-2024
Chalmers University of Technology
M.Sc in Architecture
Architecture and Urban Design

2019-2022
Chalmers University of Technology
B.Sc in Architecture

Master's Studios

ACE490
Building on Contexts and Buildings

ARK132
Matter Space Structure II: After Building

ARK128
Architecture and Urban Space Design

Acknowledgements

I would like here to acknowledge some of the support I received – both privately and academically – while working with this thesis.

Firstly, to my family – mum, dad, and Sara and Johanna – I am forever grateful for your love and support. Without you I would not be here in the first place.

Gabriel, I have enjoyed exploring our common interest in philosophy through discussions of my work. Thank you for your patience with me during stressful times.

I have to thank Elaine, Sara, and other friends, for boosting my confidence when at its lowest and for making me laugh when I am worried the most.

Many thanks to Tove and Ida for rewarding conversations before, during, and after tutorials, and for your positive attitude towards my project.

Thank you to guest reviewer Tor Lindstrand for a fun final review; it is a privilege to have the project read through and discussed with such interest.

Not least I want to thank my supervisor Karin Hedlund and my examiner Daniel Norell for your guidance, references, and for incredibly sharp comments throughout the process.

Bibliography

Ackerhans, B. (2023, September 25). *Villa Denninghoff – en dold pärla med myllrande historia*. Digitalt Museum. Retrieved February 27, 2024, from <https://digitaltmuseum.se/0211813922953/villa-denninghoff-en-dold-parla-med-myllrande-historia>

Ahmed, S. (2006). *Queer Phenomenology: Orientations, Objects, Others*. Duke University Press.

Allen, L., & Pearson, L.C. (Eds.). (2016). *Drawing Futures: Speculations in Contemporary Drawing for Art and Architecture*. The Bartlett School of Architecture.

Archer, J. (2005). Social Theory of Space: Architecture and the Production of Self, Culture and Society. *Journal of the Society of Architectural Historians*, 64(4), 430-433.

Barrett, A. (2017). Noncon Form. *Log*, 41, 141–144. <http://www.jstor.org/stable/26323729>

Besler & Sons. (2014). *The Entire Situation*. <https://www.erinbesler.com/the-entire-situation/>

Chard, N. (2016). Paradoxal Sciagraphy. In Allen, L., & Pearson, L.C. (Eds.), *Drawing Futures: Speculations in Contemporary Drawing for Art and Architecture* (pp. 149-154). The Bartlett School of Architecture.

Conway, J., Kosemen, C.M., & Naish, D. (2012). *All Yesterdays: Unique and Speculative Views of Dinosaurs and Other Prehistoric Animals*. Irregular Books.

Drawing Matter. (2020). *Alternative Histories*. <https://drawingmatter.org/exhibitions/alternative-histories/>

Ehrnberger, K. (2017). *Tillblivelser: En trasslig berättelse om design som normkritisk praktik* [Doctoral dissertation, Kungliga Tekniska Högskolan]. DiVA. <https://urn.kb.se/resolve?urn=urn:nbn:se:kth:diva-202361>

Eklund, A. (2022). *Do not touch?: Speculations on historical intentions and their place in cultural heritage* [Master's thesis, Chalmers University of Technology]. Chalmers School of Architecture. https://projects.arch.chalmers.se/wp-content/uploads/2022/06/eklundandrea_LATE_25156_2197609_Eklund_Andrea_MTBooklet_2022-1.pdf

Evans, R. (1986). Translations from Drawing to Building. In Evans, R. (Ed.), *Translations from Drawing to Building and Other Essays* (pp. 153-193). Architectural Association London.

Folly. (2024, April 10). Wikipedia. Retrieved April 25, 2024, from <https://en.wikipedia.org/wiki/Folly>

Fredriksson, J., Jahnke, M., & Ernström, T.C. (2019). *NormViz: Normkritisk visualisering i arkitektur och stadsutveckling*. Chalmers Research. https://research.chalmers.se/publication/514443/file/514443_Fulltext.pdf

Goodman, N. (1968). *Languages of Art: An Approach to a Theory of Symbols*. The Bobbs-Merrill Company, Inc.

Slottsviken. (2023, July 20). Wikipedia. Retrieved February 27, 2024, from <https://sv.wikipedia.org/wiki/Slottsviken>

Weisman, L.K. (2000). Architecture. In Kramarae, C., & Spender, D. (Eds.), *Encyclopedia of Women: Global Women's Issues and Knowledge* (pp. 86-90). Routledge.

Wickstead, H. (2008). Drawing Archeology. In Duff, L., & Sawdon, P. (Eds.), *Drawing: The Purpose* (pp. 1-7). Intellect Press.

Wigley, M. (2021). Returning the Gift: Running Architecture in Reverse. In Space Caviar (Ed.), *Non-Extractive Architecture: On Designing without Depletion* (pp. 41-56). SternbergPress.

Figures

Fig. 1 / Kosemen, K.C. (2012). *Scythe-armed swans, as imagined by clueless palaeontologists millions of years in the future* [Drawing]. Tumblr. https://64.media.tumblr.com/8d493c3b1abd4bfa436d377d8cd78f7a/tumblr_n145nagTgZ1tst46wo1_640.jpg

Fig. 2 / Kahn, L. (1972). *Site-plan for an office building* [Drawing]. Drawing Matter. https://drawingmatter.org/wp-content/uploads/2020/09/14_drawing-1536x1191.jpg

Fig. 3 / Fala atelier. (2018). *Louis Kahn's site plan for an office building* [Photograph/Model]. Drawing Matter. https://drawingmatter.org/wp-content/uploads/2020/08/30_model_a-768x1152.jpg

Fig. 4 / De la Vallée, J. (1650's). *Ritning på Skoklosters slotts gårdfasad* [Drawing]. Statens Historiska Museum. <https://media.samlingar.shm.se/item/403C3F36-EFE3-4710-97A4-90AB435D8BC8/medium>

Fig. 5 / Eklund, A. (2022). *Fireplace* [Drawing]. Chalmers School of Architecture. https://projects.arch.chalmers.se/wp-content/uploads/2022/06/eklundandrea_LATE_25156_2197609_Eklund_Andrea_MTBooklet_2022-1.pdf (p. 77)

Fig. 6 / Oberger, B. (2014). *Slottsviken* [Photograph]. Wikimedia Commons. https://upload.wikimedia.org/wikipedia/commons/d/d3/Slottsviken_01.JPG

Fig. 7 / [Slottsviken entrance floor plan drawing]. (1952). Unpublished.

Fig. 8 / Malmberg, V. (n.d.). *Okänt sällskap vid Labbera* [Photograph]. Råda Hembygdsförening. <https://bilder.hembygd.se/rada/bygdebild/2017/05/Labbera-1.jpg?h=300>



Master's Thesis

Architectural Experimentation
Before and After Building