

THE REHOUSE PROJECT

Filling the gap between reuse as concept and as reality



© Miriam Andersson & Elin Nilsson
Master Thesis Spring 2020

Examiner: Liane Thuvander
Supervisors: John Helmfridsson & Ida Röstlund

Chalmers School of Architecture, Department of Architecture and Civil Engineering

THE REHOUSE PROJECT

Filling the gap between reuse as concept and as reality



CHALMERS

© Miriam Andersson & Elin Nilsson
Master Thesis Spring 2020

*Examiner: Liane Thuvander
Supervisors: John Helmfridsson & Ida Röstlund*

*Chalmers School of Architecture, Department of Architecture and Civil Engineering
Architecture and Planning Beyond Sustainability*

Gothenburg, Sweden



Image 1. Roof materials

ABSTRACT

The construction industry has a large negative impact on the environment, causing 40% of the world's CO_2 emissions. Today, during times of increased awareness of climate change, there is an increased interest in reuse within the construction industry. However, few know how to implement it in practice and there is not yet a logistics supply system that supports reuse which makes reuse processes complicated, time consuming and expensive on a commercial scale. The aim of this thesis is to contribute to the discussion regarding practical application of reuse within the architectural design process.

Through interviews and literature studies, this thesis collects knowledge from professionals within the architectural field of today's construction industry, describing what aspects affect the opportunities to reuse, what challenges exist and what they see as likely measures to increase reuse. By implementing a real design and construction project, experience is gained on how reuse works in practice beyond conceptual ideas.

Everything is project specific when it comes to reuse, which stresses the importance of architects starting their own learning process by engaging in pilot projects and taking a more active part in construction. Reuse projects require more time due to the lack of an efficient logistical supply system for reuse products. Also, the many uncertainties when working with reuse demands an iterative design process, which creates a challenging chain of consequences. Thus, architects must become increasingly flexible in their design. Architects can contribute to making reuse feasible by increasing their knowledge on material content, quality and environmental impact to be able to properly evaluate reuse choices made. Increased reflection on material qualities and properties are required during the design process.

By designing with reused materials, architects can contribute to an increasing demand which will create incentives for a logistical supply system facilitating reuse. However, in the beginning, for architects to be able to realize reuse projects, their own systems must be created by establishing collaboration with like-minded suppliers and businesses.

Keywords:

Reuse, Circular design, Reuse design, Architectural design process, Sustainable construction industry

ABOUT THE AUTHORS



Image 2. Elin Nilsson



Image 3. Miriam Andersson

Connecting through our mutual interest in reuse we feel our common creativity spark when designing within a context of existing features. We work together in this master's thesis because we share the same curiosity to go beyond concept stages and learn what works and what doesn't. Also, we want to take the opportunity that is given through a thesis semester, to develop knowledge on how we can contribute to a sustainable construction industry in our future careers as architects.

ELIN NILSSON

For as long as I can remember I've had a fascination for old things that survived years of use, always digging deep into flea-markets and second-hand shops. I highly value the quality, robustness and patina they hold, seeing potential in discarded materials. Thus, I find it more interesting and challenging to design within an existing context.

2018-2020
Master's programme Architecture and Planning Beyond Sustainability

2017-2018
Architectural intern at Liljewall Arkitekter, Gothenburg

2014-2017
Architectural batchelor, Chalmers University of Technology

*elinnilsson9292@gmail.com
0730439544*

MIRIAM ANDERSSON

I have always wanted to be able to design and build my own house, but I have felt that I lack the knowledge to build. I love old things, not only for their materiality but also for the high level of detail and the craft behind it. I feel sad whenever an old building is demolished and all the materials go to waste.

2018-2020
Master's programme Architecture and Planning Beyond Sustainability

2016-2019
*Architectural intern at Kjellgren Kaminsky, Gothenburg
Architectural intern at Nordström Kelly Arkitekter, Gothenburg
Architectural intern at DreemArkitekter, Gothenburg*

2014-2018
Architecture and engineering batchelor, Chalmers University of Technology

*miriamisabellaandersson@gmail.com
0722526662*

ACKNOWLEDGEMENTS

THANK YOU

To our supervisors John & Ida and our examiner Liane, for their expertise and guidance.

To all our interviewees, who have taken the time to share their experiences and provide valuable insight into the current situation of reuse in the construction industry.

To our client, Linus and Sofia, for seizing the opportunity to let us build their future home and for accepting the conditions of this accelerated process.

To all the inspiring people working at Egnahemsfabriken. Their driven way of working, experience and community in combination with the infrastructure for self builders was absolutely crucial for our chances to realize this project.

A SPECIAL THANK YOU

To Christian, who have guided us through the construction with patience, creativity and support.

To Raed for all his creative construction hacks, trying to teach us arabic and for keeping the mood up with constant corona jokes.

To John, for welcoming us to stay in his cozy home at Tjörn.

To Tinna, for believing in our idea, always being positive and welcoming us to Egnahemsfabriken.



Figure 1. Logo of Egnahemsfabriken at Tjörn



Image 4. Metal screw

TERMS AND DEFINITIONS

CO₂ equivalents

A common unit for all greenhouse gases to compare the global warming impact they have, measured in the amount of CO₂.

Deconstruction

Deconstruction of a product with the aim to take care of it for reuse or recycling. A reversed building process.

Ecological footprint

A measurement on humans impact on nature. How much natural resources it takes to provide for a society or a person.

Embodied energy

Embodied energy is the sum of all the energy required to produce any goods or services, considered as if that energy was incorporated or 'embodied' in the product itself.

Energy recycling

Extraction of energy from the combustion of decay products. Classified as recycling.

Leftover material

Unused excess material from other construction sites.

Raw material

Basic material in product manufacturing that has only been processed through raw material extraction. Can also be a return raw material.

Recycling

Use of residual products. Can be divided into recycling, energy recovery and material recycling. Old materials and products are transformed into new products, energy or materials

Reuse

To use a material or product again, either for its original purpose or for any other purpose. to use again especially in a different way or after reclaiming or reprocessing

Small scale / Large scale

Small scale is defined as projects no bigger than villas and non-commercial projects that can be carried out by self builders.

Large scale is defined as projects bigger than villas and commercial projects such as multi family residential buildings, public buildings and commercial projects.

Swedish building phases

Programming and schematic design document = Programhandling.

Project planning document = Systemhandling

Construction document = Detaljprojektering för bygghandling.

Waste

Products and materials discarded for disposal. The material has lost its usability or is considered worthless by the owner.



Image 5. Roof

TABLE OF CONTENT

<i>Introduction</i>	<i>11</i>
Background	12
Objectives	14
Research questions	14
Audience	14
Scope and delimitations	15
Method	16
<i>Part 1 - Reuse as concept</i>	<i>19</i>
Circularity	20
Embodied energy	21
The relation between different values	22
Setting reuse goals	26
The reuse design process	28
Summary Part 1	37
<i>Part 2 - Reuse in reality</i>	<i>39</i>
Pilot project introduction	41
Establish collaboration	45
First Sketches	46
Early inventory	47
The client	48
Site analysis	50
Conceptual design	51
Thermal envelope	56
Final design	59
Construction start	60
Reusing metal sheets	78
End of project	84
Retrospect on budget	85
Summary Part 2	87
<i>Part 3 - Filling the gap</i>	<i>91</i>
Reflections on the reuse design process	92
Discussion & conclusion	99
Personal reflection	102
<i>References</i>	<i>104</i>
Reference list	104
Image and figure reference	107
List of interviewees	107
<i>Appendix</i>	
Appendix I - Construction drawings	
Appendix II - Presentation	
Appendix III - Logbook	

Introduction

BACKGROUND

Historically, humanity has always been reusing materials. Resource scarcity made it more efficient to reuse rather than to throw away and reproduce. With the industrial revolution in the 19th century, large scale extraction and processing of raw materials was possible. Machines and automation replaced the experience and craft of workers, making society in general lose its connection to the value of materials and incentives for reuse disappeared (Lloyd Thomas, 2007). This created a shift from circular to linear waste streams (see fig. 7), from a use and reuse mentality to a use and dispose mentality (Berge, 2009).



Figure 2. Linear waste stream

The past years' interest in reuse and circularity has increased as a counter movement to the linear make and waste society common today. The construction industry has a large negative impact on the environment, treating materials as coming from limited resources, when in fact most are not. Every year the global population is increasing with intensified demands for housing. This will require more building materials, leading to resource scarcity and increasing the stress on the environment (Lendager Group, 2019). The construction industry today stands for 25-30 % of the waste generated within the EU (European Commission, 2019). 40% of the world's CO₂ emissions are caused by the construction industry (UN Environment, 2018) where 50% of the CO₂ emissions from a building, during its entire lifetime, originates from the building process and the embodied energy of the materials used (Urban Next, n.d.). Thus, the construction industry must act and contribute with solutions.

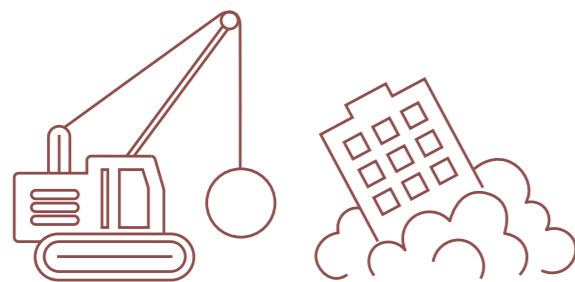

Figure 3. Demolition

Material reuse is seen as an effective means to reduce the negative impact on the environment (EPA, n.d.). As buildings become more and more energy efficient in operation and Sweden moves toward an even smaller environmental impact energy production, the relative importance of the environmental impact, as associated with the production of building material, increases (Göteborgs Stad, 2020).

To increase resource efficiency and decrease the negative impacts of production and waste management, a waste hierarchy is established to be used by the member states of the EU (European Commission, 2019). Reuse of materials is of high priority to reduce the negative climate impact (European Commission, 2019).

The UN has developed 17 sustainable development goals to protect the planet, end poverty and improve lives and opportunities for all, which are to be achieved by 2030. Goal 12 is about responsible consumption and production, which promotes construction with reuse (United Nations, 2015).

Today, during times of increased awareness of climate change, there is an increased interest in reuse within the construction industry. However, few know how to implement it in practice. Reuse projects on a small scale have been carried out by self builders many times before, though often not as thoroughly documented and reflected upon in relation to the architectural design process. Design is deliberate, which enables the architect to affect the rules of the game and have a significant role when creating a circular system for the construction industry (Lendager and Lysgaard Vind, 2018).

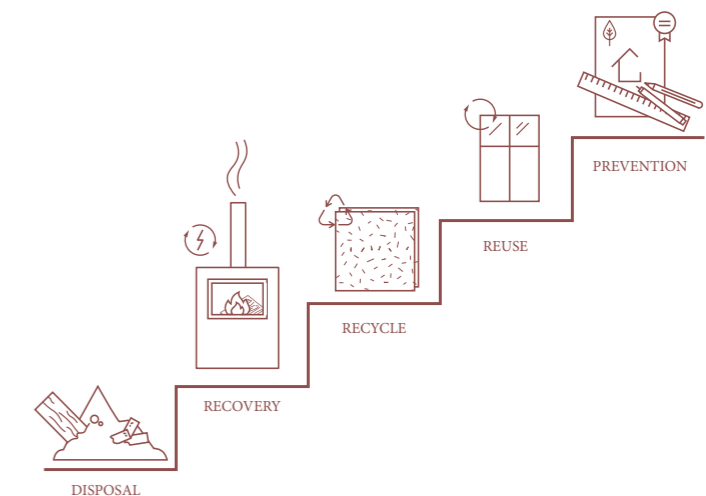

Figure 4. EU waste ladder

OBJECTIVES

- Describe what aspects affect the opportunities to reuse, what challenges exist and what is seen as likely measures to increase commercial reuse projects within the Swedish construction industry.
- Inspire and create courage and confidence among practicing architects for them to engage themselves and others in working with reuse projects.
- Contribute to the discussion regarding practical application of reuse within the architectural design process.
- Develop our own practical experience of reuse and to contribute with a well documented pilot project, to be able to transfer experience of reuse beyond conceptual thoughts.

RESEARCH QUESTIONS

- In what way can architects contribute to an increase of reuse projects in Sweden?
- What effects do working with reused materials have on the architectural design process?

AUDIENCE

This thesis addresses practicing architects, who this thesis hopes to inspire to engage in design with reused materials. Secondly, authorities, contractors, developers and individuals can find interest in this thesis to get an insight of the architect's challenges when designing with reused materials and the opportunities that can be provided through increased collaboration among architects and stakeholders.

SCOPE AND DELIMITATIONS

This thesis focuses on constructions of new buildings by reuse of individual materials from buildings that are renovated or demolished. There are structural obstacles for reuse in the construction industry and this thesis will give a brief overview of these obstacles. However, a thorough investigation of all aspects is not presented, as well as governmental and legal issues regarding reuse.

Renovation of buildings must be prioritized higher than demolition, but renovation methods and processes in itself are delimited from this thesis, as well as questions of heritage held by the reused materials.

Both in new construction and renovations, design for disassembly is important to be able to reuse building parts. However, this thesis will not investigate the design principles for disassembly. Upcycling of scrap materials from industrial production of new materials, as well as of domestic waste are delimited.

Even if production of new materials and products can cause harm to biodiversity and humanitarian working conditions, this thesis focuses on the environmental impact of products in relation to reuse. To make choices of what materials to reuse, the climate impact of materials are based on general information on embodied energy of materials. However, further Life Cycle Analyses nor embodied energy of individual materials is delimited. Nor was there time to compare exact properties and costs of individual materials.

Due to limitations in time, the project carried out during this thesis is limited to a small scale. Aspects of interior and furniture is delimited, as well as reuse of installations and electronic products. The construction of the documented project, was not finished. Thus, it is not possible to evaluate the final budget of the project.

METHOD

The thesis booklet is divided into three parts developed with different methods. The thesis is largely developed with knowledge collected from interviews and experience from design and construction of a small house. The focus is development for a Swedish context, though seeking inspiration and good examples internationally.

PART 1 - REUSE AS CONCEPT

Reuse as concept is the theoretical part where the method research for design is used to collect and develop conceptual thoughts on how working with reused materials affects the design process.

To create a base of knowledge, literature studies have been carried out. To deepen the understanding and collect knowledge and reflections of professional experience within the field of reuse, interviews with architects and stakeholders within the construction industry, have been carried out.

PART 2 - REUSE IN REALITY

Reuse as reality is the pilot project part where the methods research by design and research by practical experience is used. To develop practical experience of reuse, a real design and construction process has been implemented through designing and building a small house at Tjörn, together with Egnahemsfabriken, for a client in Varberg. The intent has been to document the process to contribute to an experience transfer.

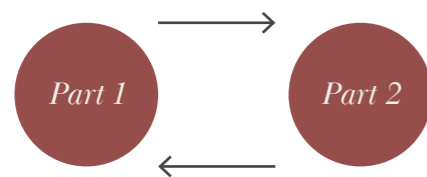

Figure 5. Part 1 and part 2 inform each other

PART 3 - FILLING THE GAP

Filling the gap is where part 1 and part 2 are put parallel and reflections are made of how they inform each other. The small scale of the pilot project has an impact on the design process, however, large scale buildings have other and often greater challenges when it comes to implementing reuse. Thus, part 3 also reflects on how the experience from the small scale pilot project can be implemented on a larger scale.

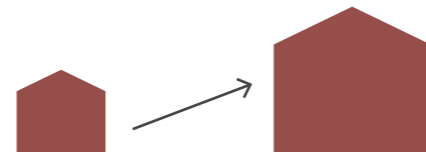

Figure 6. Small scale experience implemented on large scale

REFERENCE PROCESSES

The investigation of the reuse design process (see fig. 9) in this thesis departs in the description of the architect's design process for local materials and reuse in Ida Röstlund's architectural master's thesis (see fig. 7). The proposed process in Röstlund's thesis is inspired by the design process of the Dutch office Superuse Studios in Rotterdam, who is one of the leading offices working with reuse in Europe (Röstlund, 2017, p. 85). To put the process in a Swedish context, the Swedish standard phases of a building process described in Johansson (2018), have been used as a complimentary basis (see fig. 8).

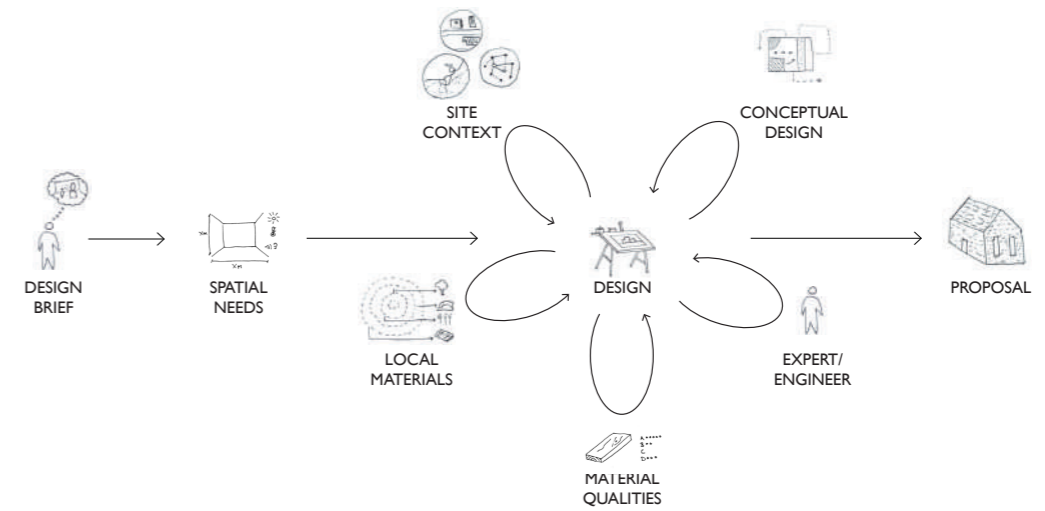

Figure 7. Design process with reuse and local materials. From *Form Follows Material* by Röstlund (2017, p. 85)

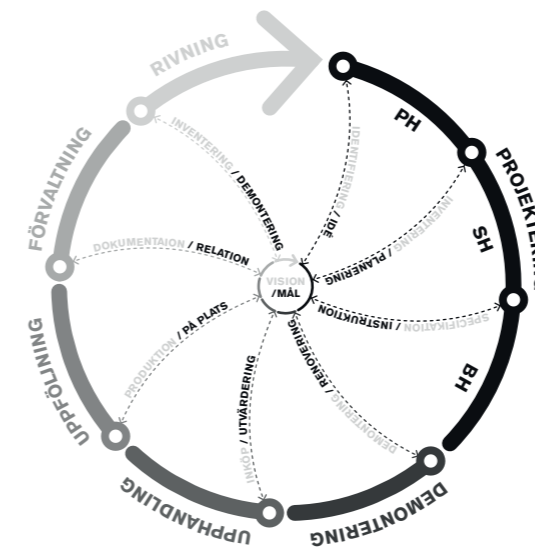

Figure 8. From *Arkitektens Återbruksmetodik*. Johansson (2018, p. 10)

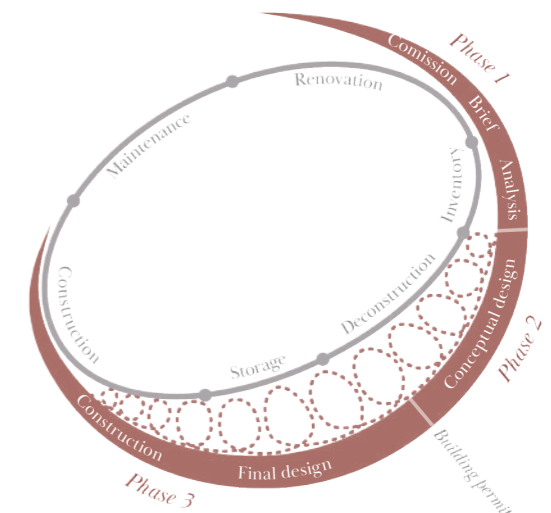
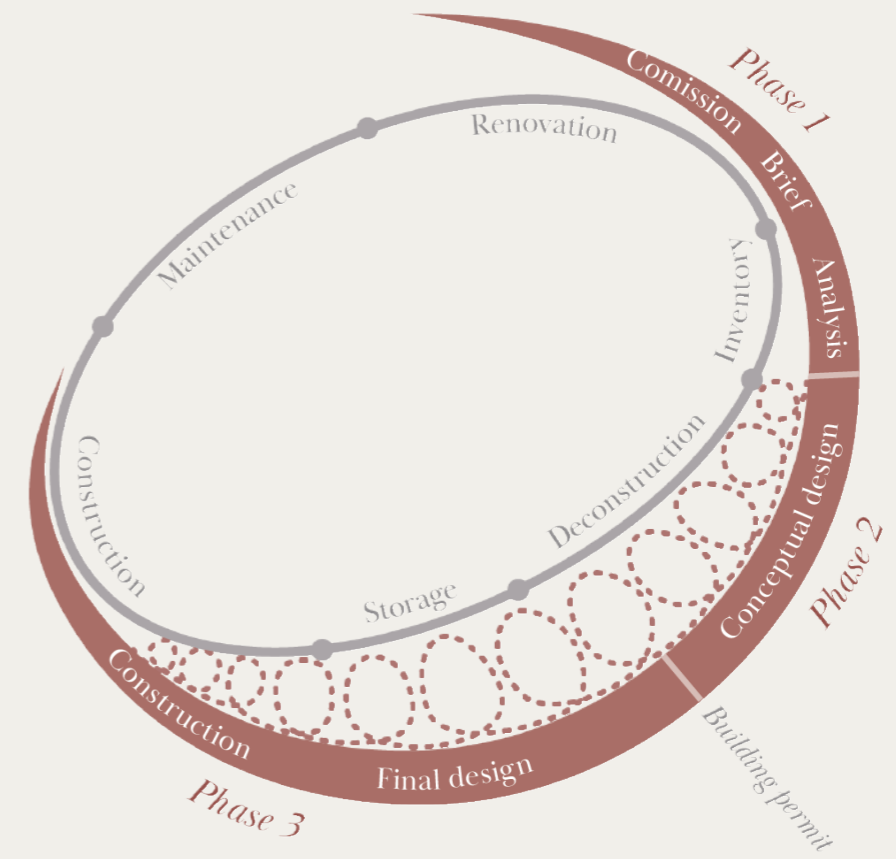

Figure 9. Illustration of the reuse process presented in this thesis



Part 1

Reuse as concept

The interest in reuse is big today but few know how to implement it in practice. A circular construction industry with reused materials is possible but is not yet a natural part of the system of today (Göteborgs Stad, 2020). This chapter presents selected concepts related to reuse and investigate the opportunities with and incentives for reuse and what obstacles there are in the construction industry today.

CIRCULARITY

“A circular economy is one that is restorative and regenerative by design and aims to keep products, components, and materials at their highest utility and value at all times” - Ellen MacArthur Foundation (2015, p. 2)

CIRCULAR ECONOMY

Circular economy (see fig. 10) is based on circular flows in a closed system where waste does not exist and products are reused and shared instead of discarded (Johansson, 2018) which celebrates a reduce-reuse-recycle mentality (Kenniskaarten, n.d.).

Linear economy is based on the cradle-to-grave mentality where new raw materials are being processed into a product which is discarded when it has been used, creating a lot of waste, causing resource scarcity and major climate problems (Lyngsgaard, Guldager and Jorgensen, 2013). This mentality sees natural resources as eternal and waste as something natural to take-make-dispose (Kenniskaarten, n.d.).

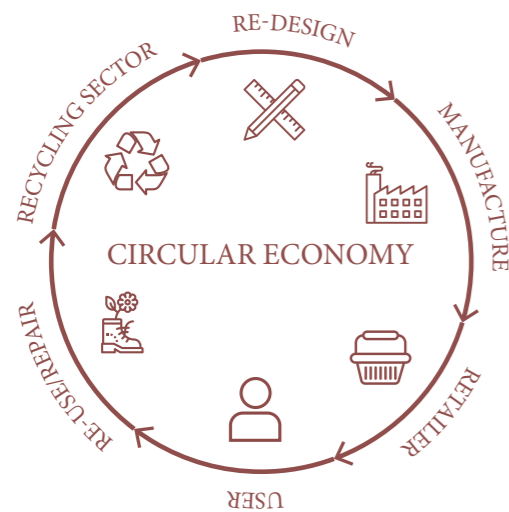

Figure 10. Circular economy

CIRCULAR DESIGN - C2C

Cradle to cradle (C2C) is a design strategy that sees everything, even waste, as a resource for design, aiming to close the loop of products and materials, and seeing reuse as crucial to achieve a circular economy. The strategy is inspired by the laws of nature, where all nutrients are circulating in a closed loop, and was founded by architect William McDonough and chemist Michael Braungart and developed as a countertrend to the linear system (Lyngsgaard, S., Guldager Jorgensen, K, 2013).

C2C is based on three principles:

- To see waste as a resource
- To use renewable sources - wind and solar power
- To celebrate diversity in cultures, solutions and species

There are two types of circular flows for materials, one biological and one technical. Biodegradable materials are included in the biological cycle. Materials that can be reused without losing quality, recycled or set apart are part of the technical cycle, which is the focus of this thesis (Lyngsgaard, S., Guldager Jorgensen, K, 2013).

EMBODIED ENERGY

Embodied energy is the sum of energy [MJ/kg] required to produce any material or product including extraction, manufacturing, transportation, construction, considered as if that energy was incorporated or 'embodied' in the product itself.

MATERIALS

According to different studies on buildings, window glass, concrete, drywalls and bricks have the largest embodied energy in constructions (Azari, 2019). Thus, these materials are important to reuse. Almost one third of GWP (global warming potential) impacts are derived from the production of concrete (European Commission, 2014) where the cement, a component in concrete, causes 95% of the total CO₂ emissions of concrete (RISE, n.d.). In addition to concrete, metals like aluminium, copper and steel, commonly used in construction, are materials which get high embodied energy due to their energy intensive extraction and processing (European Commission, 2014). The environmental impact of glass production is caused by emissions during the melting (AGC-glass, n.d.), making reuse of glass a priority prior to recycling, since melting is not avoided in glass recycling.

IMPACT ON EMBODIED ENERGY

Due to development reasons, buildings in the city have considerably shorter life spans than buildings in the countryside, where cause for demolitions often are wear (Josefsson, 2019). Thus, it is relevant to look at the embodied energy of a building in relation to its lifetime, making high embodied energy more acceptable for buildings that stand for ages. However, 25% of the buildings demolished in Sweden since 1980, were less than 30 years old (Thormark, 2007).

The distance and kind of transport influences the embodied energy of a product. A material that has generally negative impact on the climate, but is locally produced, can have a lower embodied energy value than a more sustainable material that has been transported a long way. By choosing materials produced locally, decreasing distances of transport, and using reused or recycled materials instead of new materials, the embodied energy of a building is lowered (YourHome, 2013). It is important to do a Life cycle analysis (LCA) on the materials, but keep in mind, when looking at embodied energy diagrams, that they differ depending on location and what is defined as local materials (YourHome, 2013).

25% of the buildings demolished in Sweden since 1980, were less than 30 years old

“Given the difficulty in calculating the embodied energy of reused materials, it is nearly impossible to compare the same structure between new and reused... as all of the values contributing to the total embodied energy would be project-specific in a reuse situation. One may assume that since no new material is procured when constructing with reused material, the embodied energy from resource extraction, transportation, processing, etc. would be significantly less than a construction consisting of new materials.” - Josefsson (2019, p. 94)

THE RELATION BETWEEN DIFFERENT VALUES

The high price on labor in Sweden creates a reputation of reuse to be costly and the lack of structure for reuse in the construction industry today makes it a complicated process. The environmental savings and other values of reuse are often overlooked in favour of short-term financial gains. When choosing materials to use in a building, several aspects need to be taken into account.

FINANCIAL FEASIBILITY

The relatively high price on labor in comparison to those of materials is one of the problems the reuse process is facing (Rose and Stegemann, 2018, p. 14). Commercially, this makes reused materials expensive, when the cost of deconstruction, storage, refurbishment and transport of reused materials quickly reaches the cost of new materials (Bismark, 2020). In the case of non-commercial projects conducted by self builders the picture of cost is the opposite. Then the labor is mostly free and new materials are expensive. Thus, reuse is more widely spread among these kinds of projects.

Everything that doesn't have a functioning system yet will always be more expensive and more complicated in the beginning

Everything that doesn't have a functioning system yet will always be more expensive and more complicated in the beginning. For reused materials to be financially competitive to new products, the demand for reuse products need to increase for the market to create the systems needed for a circular construction industry (Rose and Stegemann, 2018). By designing with reused materials, the architect can contribute to increasing the demand.

ENVIRONMENTAL IMPACT

It is problematic to only look at the costs of labour. Priorities of what materials are worth reusing have to be made with several aspects in mind and the focus must shift towards what other expenses and other values can be saved by reusing a product. It must be of high priority to reuse a product of high embodied energy in order to keep and utilize the energy needed and environmental impact caused to produce a product.

By designing with reused materials the architect can contribute to increasing the demand

MATERIAL QUALITY

Every building must be durable and constructed to have as long lifespan as possible. Thus, the quality of materials and building parts must always be of high priority, both when choosing reused materials and new materials (Johansson, 2018).

When comparing the cost of reused materials and new materials it is important to not compare apples with oranges. A. Franker (personal communication, February 11, 2020), reuse consultant, questions why reuse always has to strive towards being cheaper than new materials, considering the quality that reused materials can possess.

He exemplifies this with a project where a marble floor was dismantled and put in a new building. The reused marble was more expensive than putting in a new concrete floor, due to the labor costs. However, the material quality and beauty of having a marble floor compared to a concrete floor was worth the cost of deconstruction, and probably cheaper than a new marble floor.

A.-M. Blixt (personal communication, February 11, 2020), architect engaged in developing reuse projects at Link Arkitektur in Gothenburg, argues that the point of reuse is to achieve high quality in buildings over time and to ensure that quality products are not discarded prematurely. Thus, there is no point in reusing poor quality materials for the sake of it, especially in commercial projects where the labor costs are expensive.

ARCHITECTURAL VALUE

In any project, one of the main contributions of an architect is the ability to care for the aesthetics and the creation of good architecture, of beauty in buildings and spaces. If a building is loved, it is also taken care of, making it last longer and in the end it is a more sustainable building (Josefsson, 2019, p.24).

“Even a building made in paper can be permanent as long as people love it. Even a concrete building can be very temporary if that is made to make money.” - Shigeru Ban (2013)

However, buildings that were considered ugly and of no value during the demolition hysteria in the 1960's are now considered having great cultural and aesthetic value, whilst the million programme buildings that the demolitions gave way for are now threatened by demolition. What is considered beautiful constantly changes over time and comes back again.

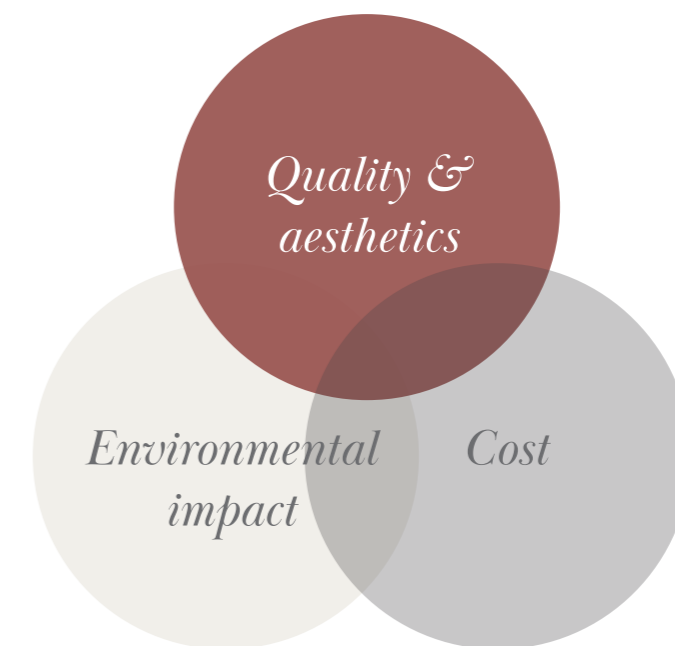

Figure 11. The relation between different values

REUSE APPROACHES

The projects Upcycle studios in Copenhagen and the townhouses in Svartlamon in Trondheim are two examples of projects raising the discussion around reuse through their different aesthetic and financial approaches.

Upcycle Studios by Lendager Group, situated in the residential area Ørestad in Copenhagen, consists of 20 townhouses constructed of mainly reused materials between 2015-2018 (Tidningen Byggmaterial, 2020). The characteristic aesthetic expression is created by the large asymmetrical system of reused window glass put in new wooden frames, in combination with an overall high level of carefully designed architectural finish, creating a uniform expression throughout the houses.



Image 5. Upcycle studios by Lendager Group



Image 6. Townhouses in Svartlamon by Nøysom arkitekter (Photo by Nøysom arkitekter)

...one can see that the aesthetics of reuse is about how the materials are reshaped ... and how it is controlled by the architect

Svartlamon is a residential area and an experimental arena for city ecology in Trondheim. Between 2015-2017, five townhouses were built mostly by the future residents. Reuse and low costs were keywords for the anti-commercial foundation financing and renting out the houses (Stenberg, 2020). All floor plans, created by Nøysom architects, look basically the same and were made flexible for the residents of the houses to be able to choose the appearance of the facade and the interior themselves. Due to the low budget, a “take what you have” mentality was created, which has given the area a varying character (Stenberg, 2020).

It is very time consuming for a carpenter to make the kind of custom made windows used in Upcycle Studios. Thus, they are probably expensive according to C. Olsson (personal communication, February 12, 2020), window restoration specialist of cultural heritage buildings at Tvåtumfyrå Byggnads AB. Lendager Group states that the cost of the project is equal to a construction with new materials (Tidningen Byggmaterial, 2020). However, one can assume and have in mind that this kind of high architectural design level and material quality, at a central site in Copenhagen, makes the project relatively expensive regardless of material origin.

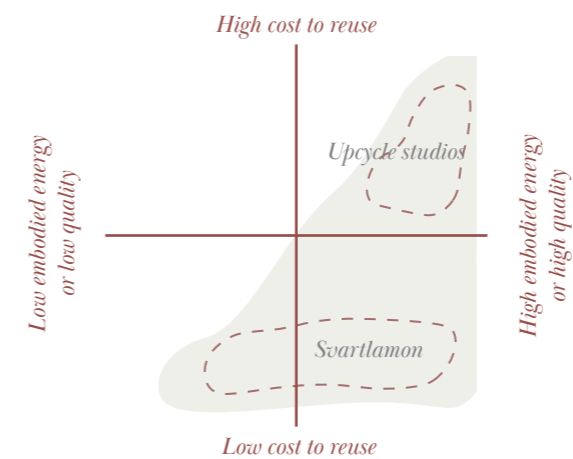

Figure 12. Diagram showing the relation between embodied energy/quality and cost, highlighting an estimated difference between Svartlamon and Upcycle Studios.

By looking at these two very different projects, both made of reused materials, one can see that the aesthetics of reuse is about how the materials are reshaped, departing in the prerequisites of the budget, and how it is controlled by the architect.

On one hand, one can accomplish a building with high quality and aesthetics, with well thought out material choices and the costs thereafter. On the other hand, one can achieve a building with a completely different expression by designing with what you have and what you can get for free or for a low cost (see fig. 12).

The form of reuse in Upcycle Studios has values as a signal of reuse, drawing attention to the reuse project. Also, reusing the glass with new wooden frames has saved 52% co2e (Lendager and Lysgaard Vind, 2018, p. 163). In Svartlamon, social values of self-construction and low cost housing have created a different value, contributing to a low environmental footprint as well.

SETTING REUSE GOALS

FLEXIBLE AND MEASURABLE GOALS

A common vision of reuse among the stakeholders involved in a reuse project is important, but setting specific reachable goals at the very start of a project is difficult. B. Johansson (personal communication, January 29, 2020), architect and development manager of transformation and circularity at White Architects in Stockholm and author of the report Arkitektens återbruksmetodik (2018), describes reuse projects as having more unknown factors than projects with new materials. Thus, the goals need to be flexible, adaptable and motivate the project group to take a step back and reflect on what choices are most climate beneficial under the current circumstances (B. Johansson, personal communication, January 29, 2020).

Before setting goals in a reuse project the existing conditions of the project must be investigated

However, most stakeholders prioritize minimization of costs at every given chance and without a specified goal of minimum reuse amount the intended reuse vision risk to be over run (A.-M. Blixt, personal communication, February 11, 2020). Before setting goals in a reuse project the existing conditions of the project must be investigated (Johansson, 2018). Otherwise, the goals are set without a context and might be unachievable. It is also important to agree on a method to reach the goals (Johansson, 2018). This will help clarify the process ahead for the stakeholders and motivate the project group to create supporting structures such as time plan and logistics chain allowing flexibility, storage of reused materials and procurement of the competence needed.

UNITS

J. Helmfridsson (personal communication, February 12, 2020), architect and sustainability specialist at Wingårdhs and tutor of this thesis, states that there is a huge difference in environmental impact outcome whether a goal is measured in kilograms of reused materials or in CO₂e equivalents (CO₂e) saved. Reuse of heavy materials such as concrete, where the reused concrete is crushed and replace the gravel when the emissions really is generated by the production of cement, can make the project reach the set goals without lowering the buildings emissions substantially. Measuring the goal in CO₂e clarifies whether the reused material actually helps create a building with a small ecological footprint or not (J. Helmfridsson, personal communication, February 12, 2020).

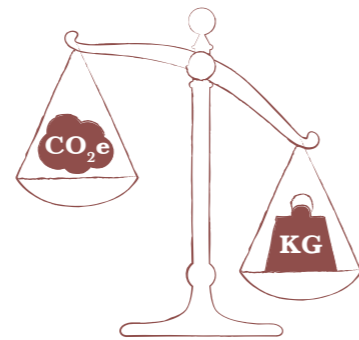

Figure 13. Measuring reuse in kilograms or CO₂e

However, it is hard to find information on CO₂e for building materials in Sweden today, due to the lack of EPDs (Environmental Product Declaration). In Norway, EPDs are very common for building materials. According to M. Svensson there must be a demand for proper material information regarding environmental impact for every material, including CO₂e (White Architects, 2020).

Setting goals such as that the building will be constructed out of 80% reused materials, say little about climate impact, quality, intended aesthetics and do not support the project team in making priorities most beneficial for the climate. Instead, a more clearly formulated goal might be such as the building will emit 80% less co₂e through construction with reused materials compared to a building constructed out of new materials.

You cannot solve everything at once, think about what are reasonable goals and what the purpose of the project is, every project is unique

When looking at other countries, both Holland and Denmark are ahead of Sweden regarding reuse in the building sector. In Holland, the legislation requires that at least 80 % of materials from demolitions must be recycled and used in new build projects (Berge, 2009).

However it is not known in what unit the percentage is measured. Dutch experience shows that reusing old buildings, which usually contain simple and natural materials, are easier to recycle and reuse. With today's building materials, with lots of composites and hazardous materials, it can become quite problematic to handle and recycle (Berge, 2009).

Goals in reuse projects can also be financial ones to create frames for the priorities within the project. For example the cost of reused materials must not exceed the cost of new materials by more than 20%.

L. Conradi (personal communication, February 3, 2020), architect of renovation and transformation projects at White Architects in Gothenburg, states that you cannot solve everything at once, think about what are reasonable goals and what the purpose of the project is, every project is unique.

GENERAL GUIDELINES TO SET ACHIEVABLE GOALS IN REUSE PROJECTS :

1. Analysis of the context investigating the conditions of the project.
2. Make a priority list, which defines what building parts, containing high embodied energy, is possible to reuse within the frames of the project.
3. Set specific minimum goals in relation to the context, defining how much co₂e will be saved. The goals should be flexible allowing the project group to re-evaluate due to unforeseen events. Goals must also define what value in terms of aesthetics and quality is desirable and achievable within the project.
4. Agree on a method to reach the goals and create supporting structures such as time plan and logistics chain allowing flexibility, storage of reused materials and procurement of the competence needed.

THE REUSE DESIGN PROCESS

The architectural design methodology must develop to support reuse, in order for building parts to contribute with their full potential and stay within a circulatory system. Looking at a process conceptually it is easy to visualize a linear process, even though it is often not. Research findings indicate reuse processes as needing an even more iterative and looping process than design processes with new materials. Thus, this chapter will seek to deepen the understanding of the architectural design process on a concept stage.

CONNECTING PROCESSES

The grey oval illustrates the construction industry, which is ideally circular (see fig. 14). Even if architectural competence is needed during renovation and during inventory of a building bound for demolition, it is not necessarily the same architect as involved in the design process of creating a new building out of reused materials. Thus, those parts of the architect's profession are not included in the architects reuse design process, which is the main focus of this thesis and is marked in red.

Due to the iterative process needed when working with reused materials, the boundaries between standard phases of Swedish building processes are blurred and not easily separated. Thus, they are reorganized and clustered in phases numbered 1-3, where phase 1 and 2 are the phase of programming leading up to creating the schematic design document and phase 3 is the phases of creating the project planning document and construction document as well as taking part in the construction.



Figure 14. Illustration of how the design process and a circular construction process should interact

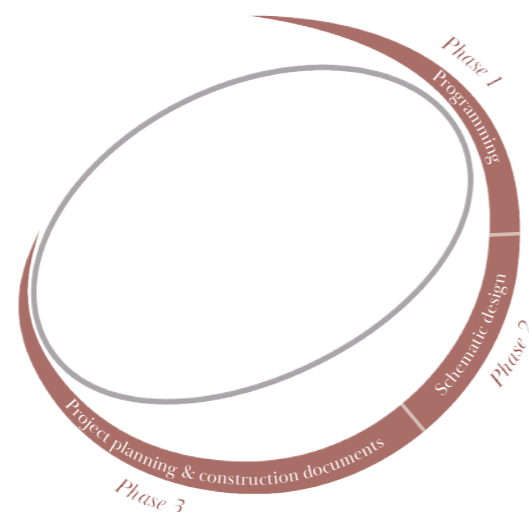

Figure 15. The design process divided into three phases where the standard Swedish phases are incorporated

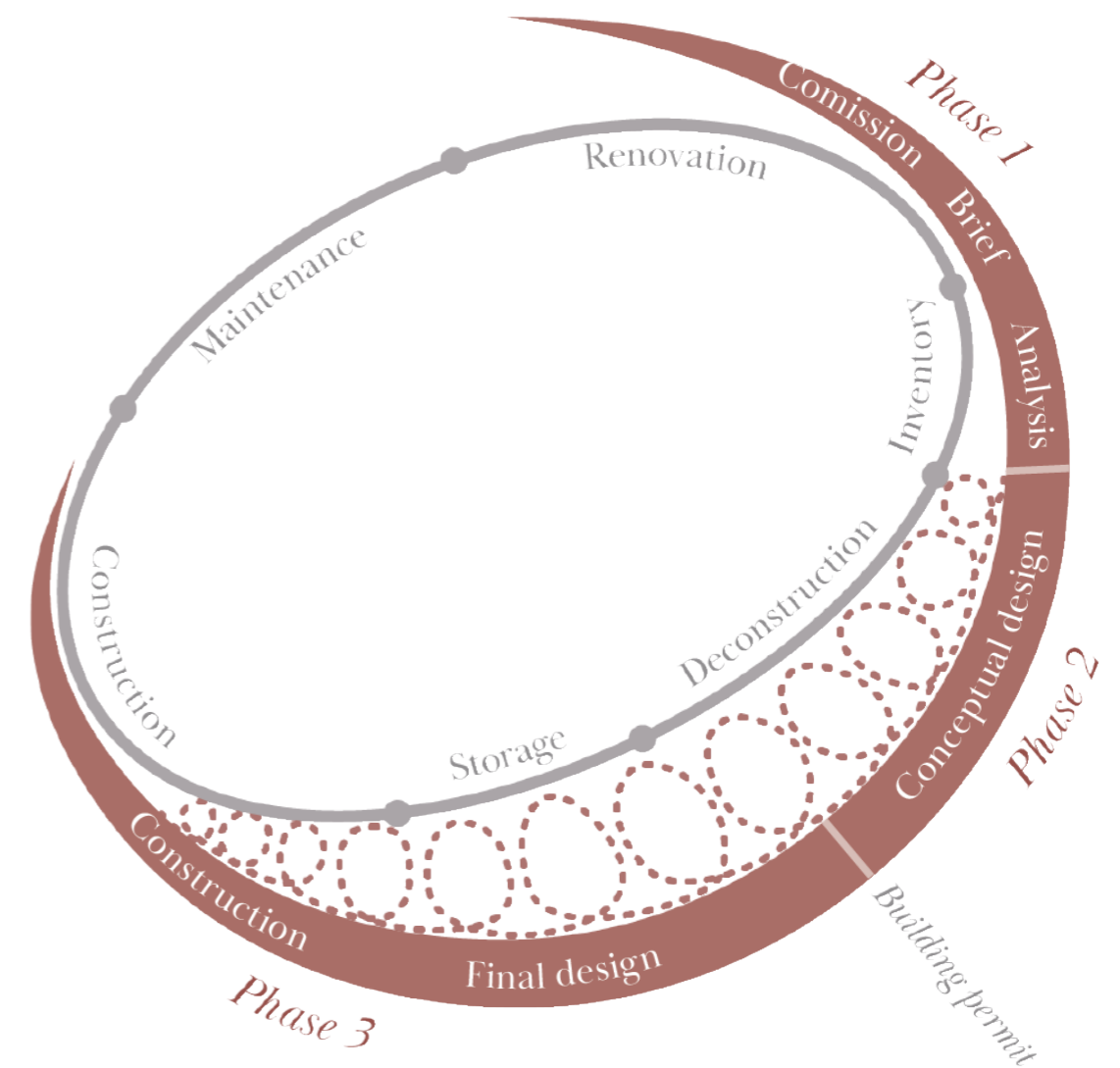

Figure 16. The proposed process as a whole, showing the need for an iterative design process. Based on research findings and the two reference processes described on page 18-19

The circular construction industry

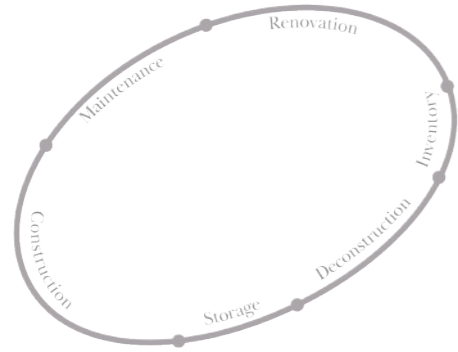

Figure 17. Illustration of the circular construction industry

CONSTRUCTION

Due to the iterative process needed when designing with reused materials and the unforeseen changes in material access, the architect must be present frequently at the construction site to assist in decisions regarding changes that affect the design, but also to make sure that the reuse vision is implemented all the way (Johansson, 2018, p. 11). Also, attending the construction site give valuable interaction, understanding and knowledge sharing between the professions and increase the collaborative capacity, both in the current project and for future projects.

MAINTENANCE

To achieve a long lifespan of the building, the possibility to easily access worn out parts is crucial. When maintaining and replacing worn out parts it is important not to use destructive techniques which might obstruct future maintenance and disassembly with retained quality (Göteborgs Stad, 2020). The more knowledge there is of a building and its parts and qualities, the easier it is to reuse parts in the future.

Thus, during maintenance of a building in use, it is important to thoroughly document the changes made by updating the as-built documents, which will ease the process of later inventory prior to deconstruction (Johansson, 2018).

RENOVATION

Reuse is a natural part of renovation projects and within its frames, architects analyse what existing materials are going to be reused. By working with renovation projects in different contexts and with different levels of preservation demand, the architect can gain experience of inherent materials and heritage qualities and a better understanding of the possibilities and obstacles of reuse in new design projects (B. Johansson, personal communication, January 29, 2020; L. Conradi, personal communication, February 3, 2020).

It is important to not start prioritizing demolition above renovation of old buildings, just because we are eager to show reuse results in new ones

Reusing materials from an existing building can be financially expensive, and in some cases hard, due to construction techniques not allowing disassembly. Thus, it is of highest priority to make the lifespan of existing buildings as long as possible through renovation. Also, renovation will make materials available for reuse before the final deconstruction of the building where materials once again enter the circulatory system of reuse or recycling (Rose and Stegemann, 2018). If there is to be a reuse revolution in the upcoming years, it is important not to start prioritizing demolition above renovation of old buildings, just because we are eager to show reuse results in the new buildings (L. Conradi, personal communication, February 3, 2020).

INVENTORY

When planning a deconstruction of a building it is important to make a thorough inventory, evaluating the possibility to reuse materials, their quality, amounts and detailed product information (Göteborgs Stad, 2020). Ideally, the as-built document has been updated with changes made during maintenance and renovation, which will ease the planning of the deconstruction.

The architects can contribute to the inventory with knowledge to identify the architectural and material qualities of products and components. To find a balance between architectural values, material quality and financial feasibility, it is important to form an inventory team of architecture, architecture antiquarian and constructor competence. In an early stage, the documentation of the inventory must be distributed to possible stakeholders for reuse planning (Göteborgs Stad, 2020). It is important to make an inventory of buildings about to be demolished, even if a scheduled new construction using the building parts, is not yet planned (Johansson, 2018).

DECONSTRUCTION

A selective demolition process is to be prioritized. When implementing a selective demolition, all parts are separated during deconstruction instead of being crushed, in order to enable recycling and reusing of materials, and to sort out all hazardous materials. If the deconstruction is well planned, and a proper inventory has been made, it will facilitate the utilization of materials (Rivningshandboken, 1999).

STORAGE

To make reuse possible, it is crucial to have a storage for all collected materials. Both for materials from deconstructed buildings, and for materials collected and purchased during the process. It is logistically, financially and environmentally beneficial if storage takes place near the construction site. However, land prices in the cities makes storage expensive. In the countryside, the lower price on land and premises, in combination with an increased access to unused spaces, feasibility to store materials is increased. On that account, the countryside has greater possibilities to create the infrastructure needed for reuse projects.

This indicates the importance of the architects creating a network of craftsmen and contractors that can upcycle and store the harvested reuse products

Lendager Group in Copenhagen and Superuse Studios in Rotterdam are two front edge architectural offices when it comes to circular economy buildings and design with reused materials. Both offices have founded independent sub companies working with upcycle product development for the benefit of the mother companies architectural office as a consequence of the lack of suppliers of refurbished products (Lendager Group, n.d.). This indicates the importance of the architects creating a network of craftsmen and contractors that can upcycle and store the harvested reuse products.

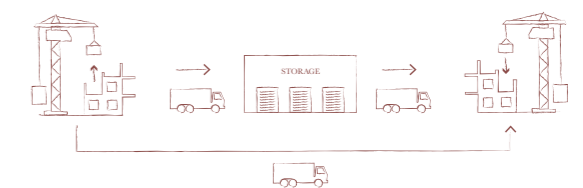

Figure 18. Logistics chain

Phase 1

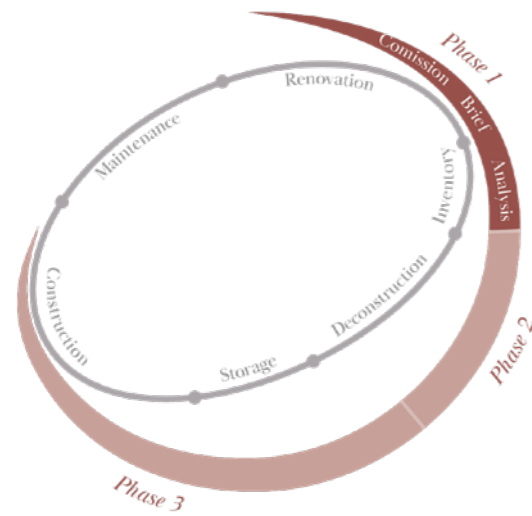

Figure 19. Illustration of phase 1 of the reuse design process

COMMISSION

An important part of innovative processes is that all the stakeholders share the same vision and are strategically aligned. But most important is that the stakeholders are willing and ready to support the vision all the way, through obstacles and crises (Lendager and Lysgaard Vind, 2018). As reuse projects are quite new in the Swedish construction industry, it is important to find collaboration with brave commissioners that are willing to take a risk to achieve innovation (A. Franker, personal communication, February 11, 2020).

Partnering would be the most beneficial form of contract for a reuse project, where the continuity of stakeholders makes it easier to preserve a common goal and view (B. Johansson, personal communication, January 29, 2020; A. Franker, personal communication, February 11, 2020; A.-M. Blixt, personal communication, February 11, 2020). Partnering is not a form of procurement in itself, but a process method for increased cooperation, created to balance the financial risk among the stakeholders (Byggherrarna Sverige AB, 2018).

Partnering contracts are procured at an early stage typically in projects with uncertain factors and calculation conditions like renovations where current account payment is necessary (Byggherrarna Sverige AB, 2018).

It is beneficial if the reuse vision is in the process from the beginning. However, A. Boström, project manager at Vasakronan, describes the project Kv. Hugin was going from having a strong demolition focus at the beginning of the project, encouraged by the municipality, to a determination of refurbishing and reusing as much as possible (White Arkitekter, 2020). In the project, containing house blocks, which created barriers, from the 70's in Uppsala, the reuse process was initiated by the developer after the detailed development plan for the area had become final (White Arkitekter, 2020).

Partnering would be the most beneficial form of contract for a reuse project

Reuse is not yet part of the Swedish building legislation. Architects and contractors must assist with methodology and good examples to provide knowledge of the process and facilitate decision making. Ultimately, the decision whether reuse is implemented or not, lies with the client (Johansson, 2018).

BRIEF

To create a brief of reuse for the project, the specific technical, esthetical and spatial needs are to be analyzed to determine whether there are certain parts of the building that specifically require new products which are unable to be fulfilled by the inventoried reuse materials (Johansson, 2018).

If it has been hard to determine the structural quality of some building component during the inventory, those parts can be used where lower requirements exist (Johansson, 2018).

To create successful collaborations the stakeholders involved need to be analyzed, mapping what competence they can contribute with or develop within the frames of the project. This will show what competence and expertise needs to be procured externally and what collaborations need to be established to achieve reuse and circularity in the project.

At this stage it is important to agree on strategies and methods for creating supporting structures for reuse such as budget, time plan and logistics chain for storage of reused materials (Johansson, 2018).

ANALYSIS

In the same way that daylight, terrain, infrastructure and soil conditions are mapped and analysed at the beginning of a project, an inventory of the conditions for reuse on the site must be a natural part of every analysis to identify existing and potential qualities and values (Johansson, 2018).

Due to the relatively high cost of reusing building parts, it is important that each building and building part has as long lifespan as possible in its original location. Thus, renovation and reconstruction must be prioritized compared to demolition and new construction (Göteborgs Stad, 2020).

GUIDING QUESTIONS DURING REUSE ANALYSIS:

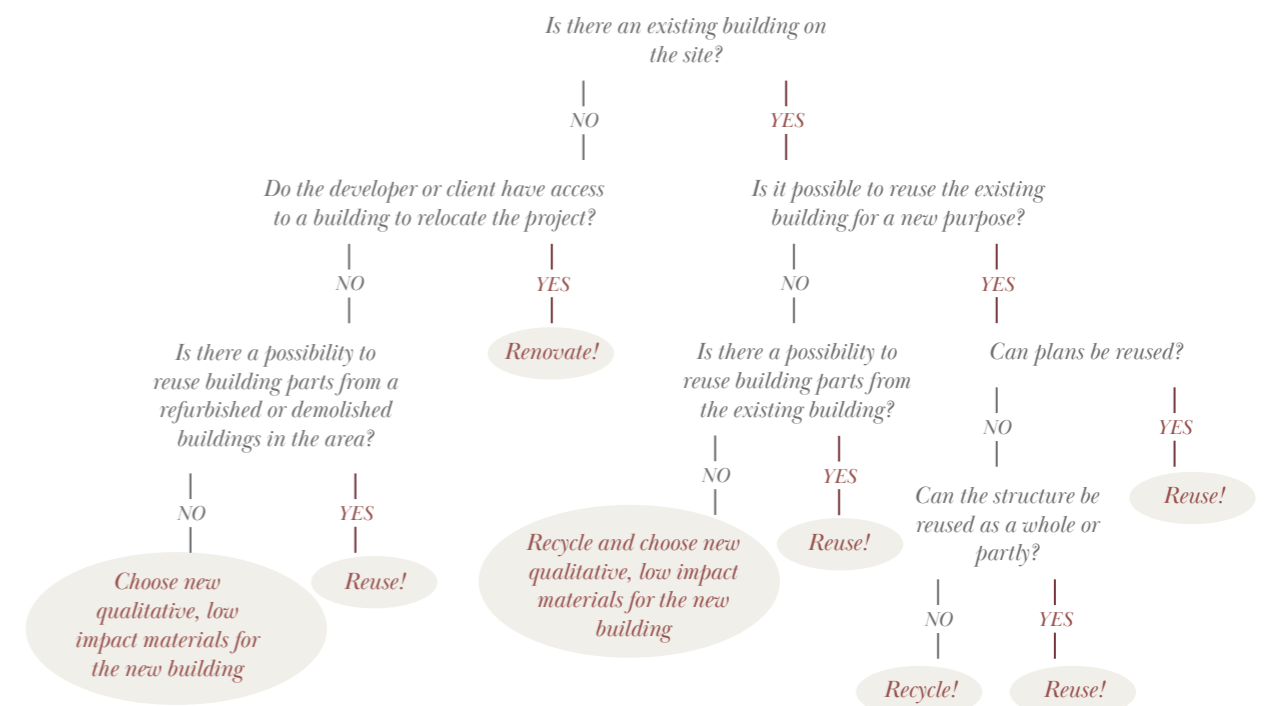

Figure 20. Guiding questions during reuse analysis. Developed from point 1-3 of White Architects reuse hierarchy in Johansson (2018, p. 4)

Phase 2

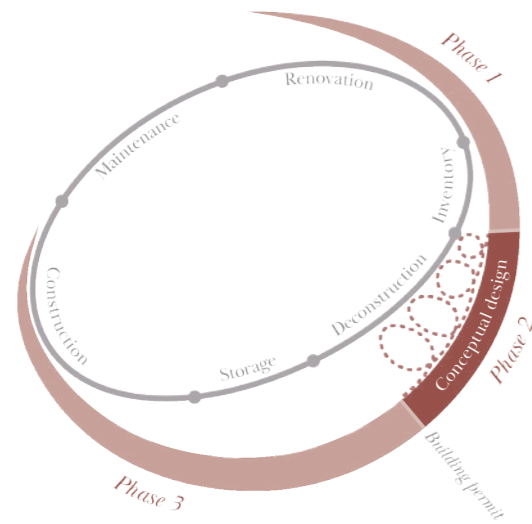

Figure 21. Illustration of phase 2 of the reuse design process

CONCEPTUAL DESIGN

The architect's task is to look at an existing building as a resource for coming projects (Johansson, 2018). Depending on the access to an existing building on the site or not, two main approaches of reuse design have been identified:

DESIGN BY SITE AVAILABILITY

Access to a building that is about to be deconstructed at the project site or match a local scheduled deconstruction, the starting point of the design is created by the style of the reusable building parts from that building. Depending on the amount of materials that can be reused and the amount of materials that must be added, the possibility to create a unified expression increases. This strategy is similar to the ones of renovation or transformation projects.

Whichever method one uses, it is crucial to have a conceptual design in order to know what available materials are of use and what materials to look for. When designing with site availability there is usually a need to look for additional materials from the reuse market as well.

S. Karlsson, (personal communication, January 30, 2019), architect at Tengbom and interviewed during a previous course at Chalmers, states that it is beneficial to develop a documented design program in order to keep the vision of the project amongst the stakeholders throughout the process.

Also, it is a good communication tool between architects and contractors

This document works as a tool to emphasize, properly explain and argue for the importance of certain design decisions. Also, it is a good communication tool between architects and contractors, which can make the contractors understand the underlying intention with the design, which in the end can make them feel more involved and encouraged to incorporate the design in the construction (S. Karlsson, personal communication, January 30, 2019).

DESIGN BY MARKET AVAILABILITY

If the site is empty or if there is no planned deconstruction nearby, materials to reuse is to be found at the reuse market, either locally or online. This gives the architect a more liberated choice of expression making the design process more similar to a process with new materials, yet more iterative. However, it requires a major change in logistics systems and access communication to implement a design methodology like this on a large scale.

The early design proposals require flexibility in the design which can be achieved by designing with interval measurements instead of precise measurements (see fig. 22). This gives room to find reused materials later in the process or if earlier choices need to change.

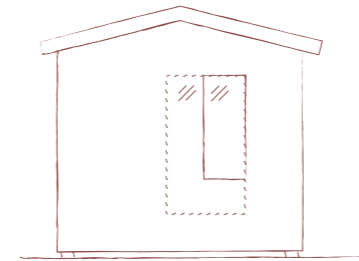

Figure 22. Interval measurements

BUILDING PERMIT

The demands for the level of detail in the building permit documents and the time consumed during the building permit process, have a major impact on the design with reused materials. Usually, specific measurements affecting the facade expression are required, such as placement of the windows. In some cases the detailed development plan requires a specific facade material. This level of detailed information is often impossible to determine at that point in a reuse process.

L. Conradi (personal communication, February 3, 2020) states that it is crucial for the realization of a reuse project that the city planning office understands the consequences of working with reused materials and accepts permits to be based on documents on a conceptual level, allowing a certain level of flexibility during the continuous design and construction process.

Phase 3

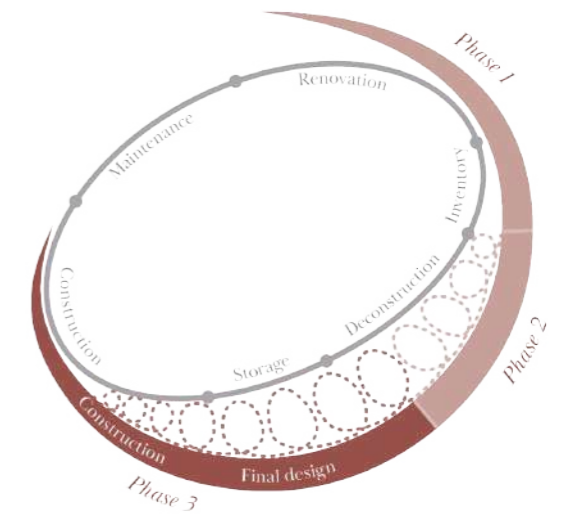

Figure 23. Illustration of phase 3 of the reuse design process

FINAL DESIGN

Due to unknown events that may occur during the construction, the design on this stage must be tolerant to iterations. To promote a design with reused materials, it is important to enable maintenance and future reuse by using standard dimensions and designing in layers, with easy access to wear out parts, extends the lifetime of a building (Josefsson, 2019; Göteborgs Stad, 2020).

Materials used must be qualitative enough to be durable over time and demountable to be possible to reuse multiple times (Johansson, 2018). By facilitating design for disassembly, the need of demolition is prevented, thus, the lifetime of the building is prolonged (Göteborgs Stad, 2020).

The design needs to make the building flexible for different needs without the building going out of fashion, which is one of the causes for demolition. However, too strict demands and specific planning for a certain user decrease the flexibility over time (Göteborgs Stad, 2020). However, creating a building that is too general, risks making it not specific enough for anybody.

SUMMARY PART 1

It is relevant to look at the embodied energy of a building in relation to its lifetime, making high embodied energy more acceptable for buildings that stand for ages. Window glass, concrete, metal, drywalls and bricks are the materials that contribute to most of the embodied energy in constructions (Azari, 2019). Thus, these materials are important to reuse and will guide the priorities made in the design and construction of the pilot project in this thesis.

Priorities of what materials are worth reusing has to be made with several aspects in mind. The relatively high price on labour must be balanced relating to high priorities of material quality, aesthetic expression and what environmental cost can be saved. Everything that doesn't have a functioning system yet will always be more expensive and more complicated in the beginning. By designing with reused materials, the architect can contribute to an increasing demand of reused products on the market, which will make reused materials financially competitive to new ones.

It is important to find collaboration with brave commissioners that are willing to take a risk to achieve innovation as well as creating a network of craftsmen and contractors that can upcycle and store the harvested reuse products.

To set achievable reuse goals an analysis of the context has to be made as well as a priority list of what building parts is possible to reuse within the frames of the project. Set specific yet flexible minimum goals in relation to the context, defining how much co2e will be saved, as well as what value in terms of aesthetics and quality is achievable within the project. However, everything cannot be solved at once, think about what is reasonable and what the purpose of the project is, every project is unique.

Due to the iterative process needed when designing with reused materials, the design must be flexible and contain interval measurements to be resilient to unforeseen changes in material access. The aesthetics of reuse is about how the materials are reshaped, departing in the prerequisites of the budget, and how it is controlled by the architect.

Architects must be present frequently at the construction site to assist in decisions regarding changes that affect the design and to develop and maintain good collaboration, which is to be further explored in the upcoming part of this thesis.

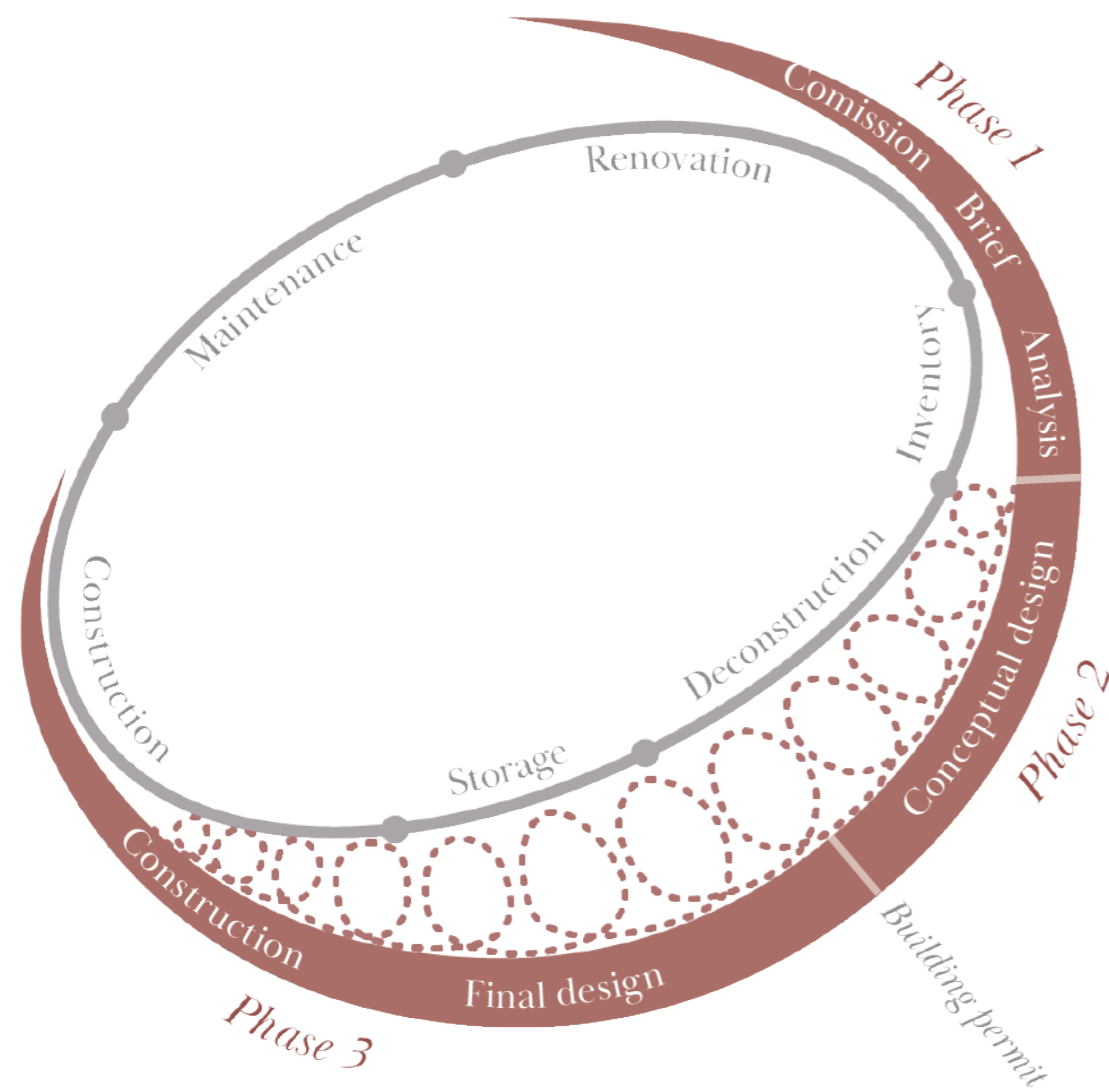
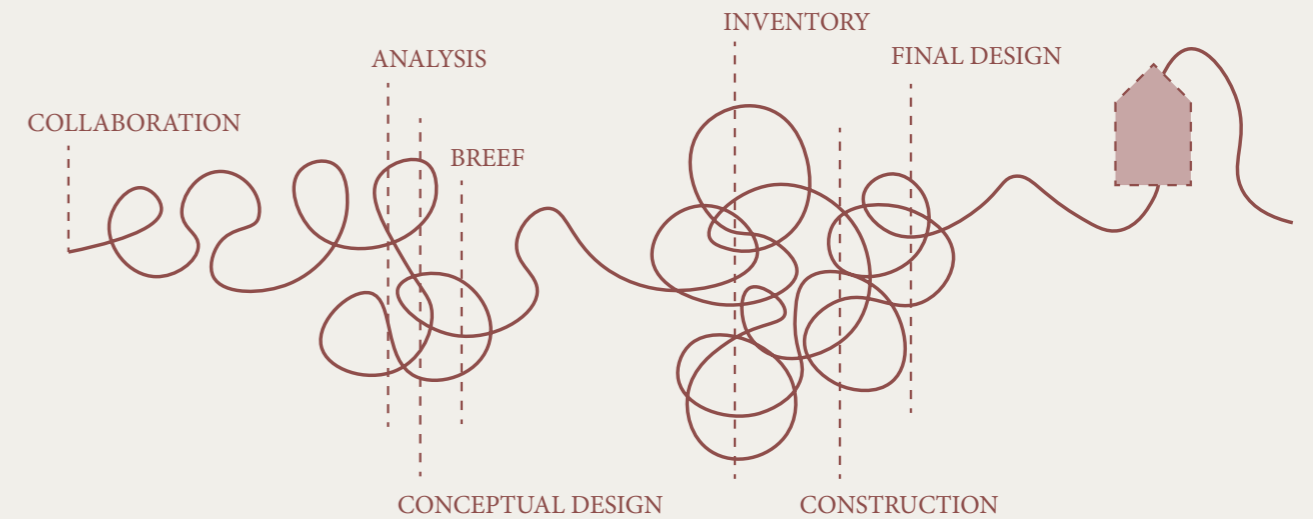

Figure 24. The proposed process as a whole, showing the need for an iterative design process. Based on research findings and the two reference processes described on page 18-19



Part 2

Reuse in reality

To test ideas of reuse and develop practical experience of how reuse affects a real design and construction process, a small house was designed and constructed in collaboration with Egnahemsfabriken at Tjörn. By documenting the process, the thesis aims to transfer experience of reuse design and construction and to inspire others in the profession to engage in reuse projects.



Image 7. The pilot project

PILOT PROJECT INTRODUCTION

The main focus of this part is not to describe how to build a small house, but to describe the exploration of a reuse design process in a self-build context and what consequences working with reused materials has on the design and construction process. The aim is to describe the crossroads where choices and priorities had to be made between reusing materials or buying new in relation to the time limits of a thesis semester and the budget, needs and wishes by a real client.

”It is important with pilot projects, to start on a small scale that is easier to grasp and to succeed with than to go big, fail and lose energy and confidence” - B. Johansson

GOALS & PRIORITIES

The idealistic goal of the pilot project was to construct a house made out of 100% reused materials. However, being realistic, reusing as much material as possible and achieving long-term quality, was the initial aim. Thus, it was important to find a client who would let reuse design be of highest priority.

In addition to reused materials, eco-friendly materials have been prioritized above buying new complementary materials with high embodied energy, where the sufficient amount of reusable materials was not accessible.

Without attracting too much focus in the process, designing for future reuse was a part of the priorities.

Since LCA calculations of specific materials that were used and reused were not performed, due to the level of complexity in such calculations, the priorities made have been guided by assumptions of what material contains high embodied energy based on the information presented in the Embodied energy chapter of part 1 of this thesis.



Figure 25. Priorities during the pilot project

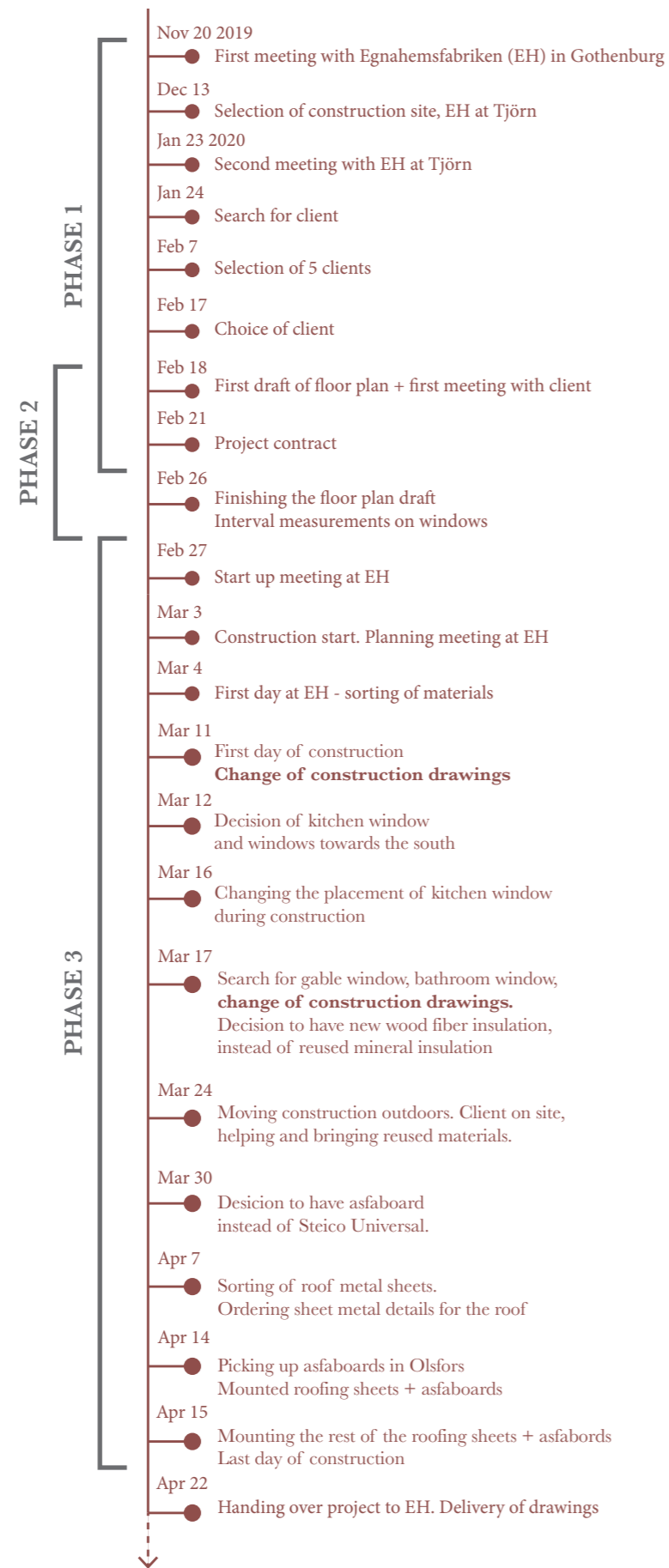

Figure 26. Timeline

TIMELINE

Initially, the time set to be spent by us as students to construct the building was 3 days a week from the middle of February up until April 24, 2 weeks before the project booklet hand in. The rest of the time was to be spent on the theoretical part of the thesis and documentation of the project for the project booklet. However, due to the delay of finding a client the construction started on March 3.

DESIGN BY MARKET AVAILABILITY

Due to the lack of knowledge of buildings bound for demolition in the surroundings of Egnahemsfabriken, design by market availability has been the reuse approach during the pilot project. Form has been following the needs and wishes of the client and the site specific prerequisites in combination with demands in the attefall regulations. The aesthetic expression has been following the availability of materials during this accelerated process as well as the wishes and budget of the client. Materials to reuse have been found online through blocket, at the storages at Egnahemsfabriken as well as by advertisement by the client in the local newspaper.

ENABELING FUTURE REUSE

By building the house on piers, the house was movable as a whole, enabling as much of the construction to be performed at Tjörn for later transport to the site. This creates a possibility for the client to bring the house if they are moving or to sell it if they no longer have need for it in the future. By using screws instead of nails to the maximum extent possible, future disassembly for material reuse or recycling is possible. The house was not designed for whole sections, such as walls, to be reusable as modules.

PROJECT PROCESS

As illustrated below design and construction with reused materials require an iterative process. For several reasons, such as limitations in time at the beginning of the process, the general steps of the process overlap. The aim is to describe the design and construction process chronologically. However, to bring clarity around how reusing certain materials was implemented and how it affected the process, the main reused components are clustered yet integrated in the chronology.

To be able to properly understand and explore the process of reuse, building the house as self-builders, with tutoring and help, was important to get perspectives of the fuzzy term “time consuming construction”.

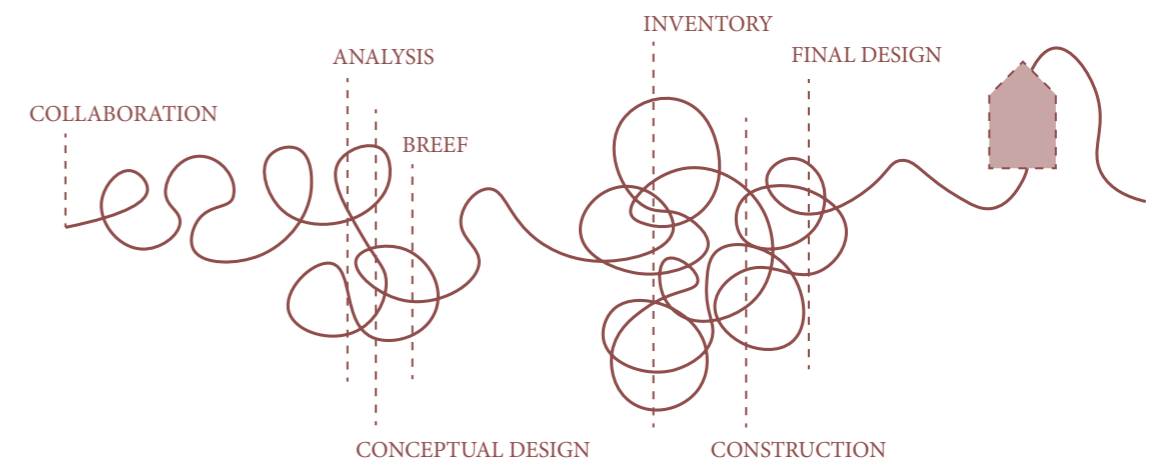

Figure 27. Pilot project process



Figure 28. Map of Sweden



Image 8. Egnahemsfabriken



Image 9. Egnahemsfabriken



Image 10. Egnahemsfabriken

Phase 1

ESTABLISH COLLABORATION

FIRST CLIENT

The first client was introduced by the thesis examiner during the early fall of 2019. The client wanted a tiny house on wheels to support his flexible and free lifestyle, which was a construction size well fitted to the time limits of the thesis. Thus, effort was put into finding a construction site, not on finding alternative clients.

FINDING THE INFRASTRUCTURE

To be able to carry out this project within the time limits of a thesis, the infrastructure of the construction was crucial to find. In our case, the infrastructure had to contain a well organised construction site with access to tools and guidance by professionals. During the late fall of 2019 we got in contact with Tinna Harling, project manager at Egnahemsfabriken on Tjörn.

EGNAHEMSFABRIKEN

Egnahemsfabriken is a innovation project and a support structure for people who wants to build their own house or help others to build theirs in a collaborative, social and supportive environment. Their main aim is to make self-help construction a realizable alternative for people who have a hard time finding a home due to the escalating market prices, yet Egnahemsfabriken is also open for other initiatives like ours. It is located at an old farm on the island Tjörn, north of Gothenburg, with good access to public transport. Egnahemsfabriken focus on environmentally sustainable construction methods, with the aim of building with as much reused and eco friendly materials as possible (Egnahemsfabriken, 2018).

The infrastructure for self builders that Egnahemsfabriken have created at Tjörn was absolutely crucial for our chances to realize this project within the given timeframe. Their driven way of working, network, experience and community in combination with access to construction site, tools, storage of leftover materials and materials to reuse gave us the foundation to create this house upon. Not to mention the importance of guidance by professional carpenters and their business taking care of the legal obligations, finance and bills towards the client. Their work is also an excellent example of good integration and knowledge sharing between cultures.

The cost depends on how much work is done by the selfbuilder, how much of the material is reused and in what quality the house is built

CREATING THE BUDGET

As in all projects, the budget is important for the client. Talking to different self builders, trying to find information on how much the house would cost, did not provide a clear picture of the budget needed. It depends on how much work is done by the selfbuilder, how much of the material is reused and in what quality the house is built. When the collaboration was established with Egnahemsfabriken their experience gave us an approximate estimation of 300 000 sek, which was higher than the first client expected. He pulled out last minute, which left us in a situation to quickly find a new client right at the start of the thesis semester.

FIRST SKETCHES

When starting the design of the small house the decision was not yet made who was to be the client and future owner of the house. Thus, the sketches focused on investigating the general design principles of creating a good accessible home with a loft, within the limits of the attefall regulations.

ATTEFALL REGULATIONS

The maximum footprint and height of a small house without a building permit, called an Attefallshus, is 30m² and 4 meter height (Boverket, 2020). When building small Attefall houses in Sweden, there is a difference in demand of accessibility if the house is intended for permanent living (demand for accessibility) or as holiday cottage (no demand for accessibility), which was unknown at this point.

Secondly, the transport from the building site to the residence site has a width limit of 3.1 meter if transport is to be carried out without paying extra for an escort car.

Figure 29. Attefall regulations

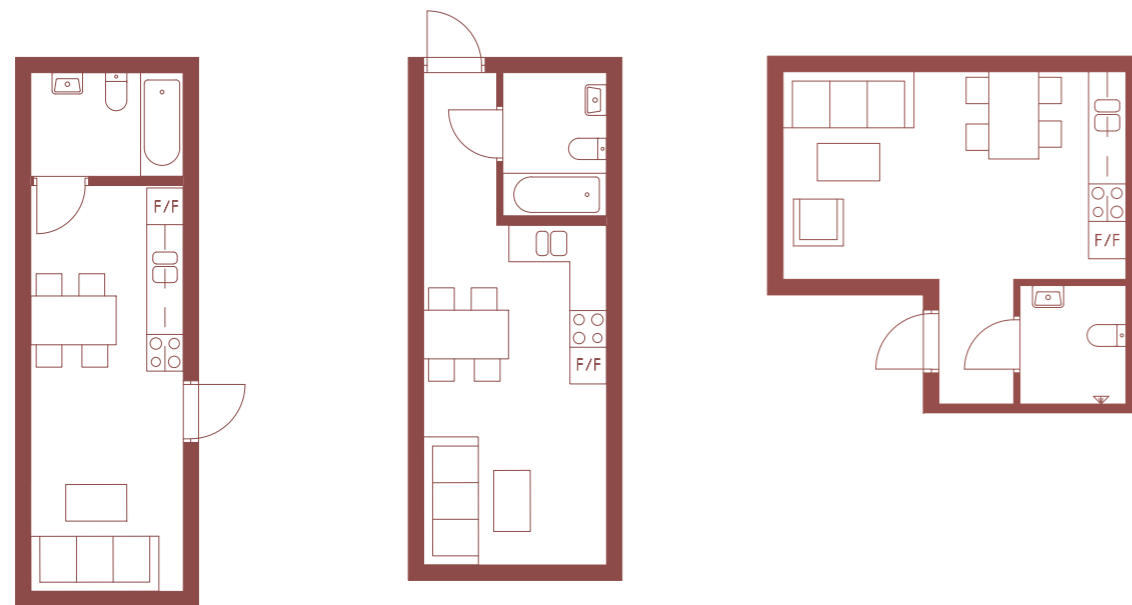

Figure 30. Narrow house of 3.1 m width for transport without an escort car. Unnecessarily big wc with no functional space beside. Better spatial qualities with a wider house.

Figure 31. Angled house to be transported in two pieces. A time consuming constructional element that would take away focus from reuse.

EARLY INVENTORY

To get an overview of what kind of materials are commonly accessible for reuse, the different reuse centers in the region of gothenburg were mapped. The materials available at their websites, at Marketplace and Blocket as well as at Egnahemsfabriken were briefly inventoried. Some of the reuse centers were visited at this point but the lack of conceptual design drawings and the fact that a client was not yet involved made it difficult to know what materials were needed and impossible to buy unique pieces without knowing who would pay for it.

WINDOWS

Apart from furniture and interior products, a considerable majority of materials available were windows and doors. However, older windows, with character and heritage, were often only sashes without frames. PVC windows were common as well but there was strong advice not to use PVC windows due to the poor quality (C. Olsson, personal communication, February 12, 2020).

KITCHEN

Due to the kitchen being a central place in the modern home and a status symbol in the Swedish home interior, making the kitchen exposed to renovation hysteria (Chalmers, 2020), this was another product of considerable amounts. The 50's and 60's development of kitchen standardisations has contributed to an increased reusability of kitchens (B. Johansson, personal communication, January 29 2020). However, the quality varies over the years and the kitchens from the early years are often easier to refurbish than later editions. Also, what is perceived as functional has changed over the years. Today, drawers packed from above are more common than cabinets.



Image 11. Windows at Egnahemsfabriken. January 23

LARGE QUANTITIES

Large quantities of left over materials, like insulation, were rare, which of course is good and indicates that many have avoided severe miscalculations of their need. However, the material inventory used mainly comes from private constructions and renovations and one can assume the larger quantities are found at commercial construction sites

THE CLIENT

SORTING PRIORITIES

Through advertisements on facebook, written in collaboration with Egnahemsfabriken, we got responses from around 30 interested clients. To quickly sort out the candidates to interview during this accelerated process, we put up 3 main prerequisites:

1. Whether they expressed excitement of reuse in their application
2. Their budget
3. Their access to a site without need for a building permit

THE CHOICE OF CLIENT

After initial interviews of 5 candidates the choice of client fell upon a young couple from Gothenburg with a plan to build a small house on a premise in Väröbacka north of Varberg. We got along very well during our initial interview. They had a strive for an eco friendly house with reused materials and a budget of 400 000 sek which was considered having good margins.

CONTRACT AND BUDGET

The contract between the client and Egnahemsfabriken, who was taking the business responsibility for the project, had to be shaped and signed. In this, Egnahemsfabriken was the driving force, and their previous experience made it efficient.

The lack of final drawings of the house, due to the late establishment of a client contract, in combination with the unknown cost of reuse products at this point in the process, made it hard to provide a clear budget for the project.

However, the client gets the time we, as students, spend on the design and construction for free, making them willing to accept the uncertainties and the condition of expenses being paid on current account. A rough estimation of budget, based on experience from previous Attefall constructions at Egnahemsfabriken, indicated a cost of around 300 000 sek excluding costs of transport to the site and foundation. The estimation was based on building with new materials and with self build as the main labour. By reusing materials at a lower cost than buying new, the time spent on tutoring and help from the carpenters would hopefully break even.

This was an extremely accelerated part of the project, which contributed to the overlapping of many stages in the project process

Due to the limits of time of a master's thesis semester, the contract made clear that there was no predetermined level of completion of the construction at the final date set for our time. The remaining work is to be executed by the client themselves or by hiring Egnahemsfabrikens carpenters to complete the house at an additional cost.

There was a pressing need to start with construction drawings and plan the building process, making this an extremely accelerated part of the pilot project which contributed to the overlapping of many stages during the process.

BRIEF

- Important to achieve an eco-friendly house. Thus, open minded towards reused materials.
- Priority of sustainable choices and quality, but prefer low price on reuse products.
- Prefer the house to have a rectangular shape.
- Gable roofs, since the rest of the buildings on the site have that kind of roof.
- Solar panels on the roof to collect energy, in addition to the already existing municipal water and energy supply to the premises.
- Fireplace to heat the house in addition to an electrical air source heat pump.
- Willing to pay extra for the transportation escort of a wider house, unlocking the measurement restrictions in the floor plan.
- No need for accessible measurements, it would take up too much space.
- Prefer to have a bedroom on the bottom floor, however a loft with a proper stair that includes storage is ok.
- Erase the boundary between inside and outside by a large glass partition on the southern side of the house that can be pushed aside.
- Priority on the kitchen space to support their mutual interest in cooking.



Figure 32. The client

SITE ANALYSIS



Figure 33. Site plan scale 1:1000

A site visit by the architect is often crucial, but the rapid process of creating the plans for the house, in combination with good access to pictures and information from the client, made the site visit not prioritized during the circumstances.

The premise is an old farm with wooden houses, used as a holiday cottage by the client's family. The main house of the farm burned down in 1906 and was rebuilt shortly after.

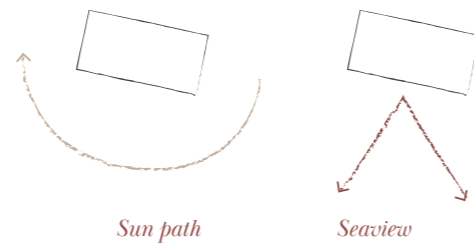

Figure 34. Analysis diagrams



Image 12. The site



Image 13. The site

Phase 2 CONCEPTUAL DESIGN

LOFT

After viewing the initial concept plans, the client agreed that a loft would be most sufficient for such a small house. The loft will be placed towards the east to avoid overheating the bedroom by the evening sun in the south west. Approaching the house from the south, the entrance and the main south facing facade of the house was to be united by a large terrace, placing the entrance door at the southern facade and the bathroom, where the demand for room height is less, underneath the loft. A mix of proposal 1 and 2 was to be developed further.

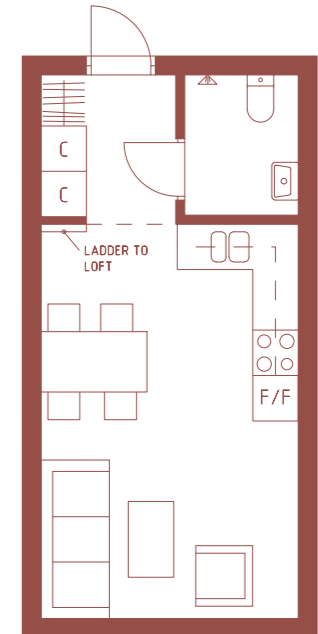

Figure 35. Proposal 1

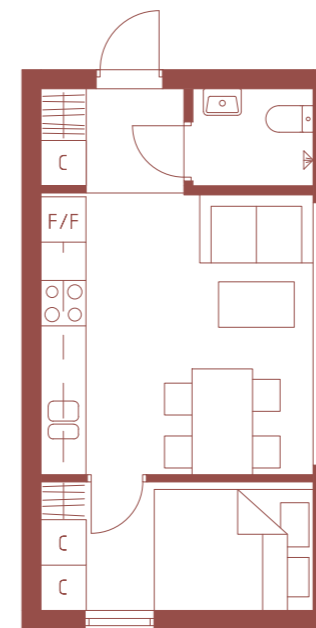

Figure 36. Proposal 2

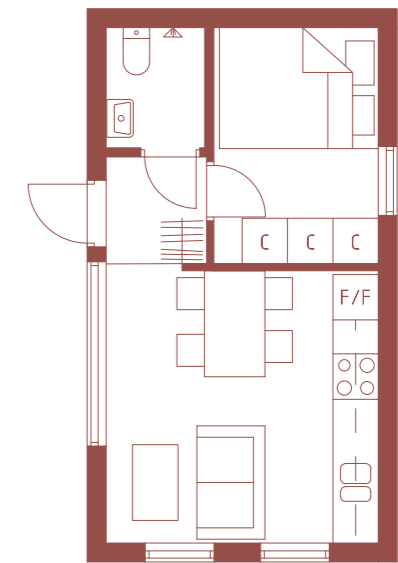

Figure 37. Proposal 3

KITCHEN

In a small house like this, the kitchen largely affects the spatiality, interior expression and the storage availability. The client's parents were renovating their kitchen after the summer, creating a possibility to reuse their old kitchen for free, which the client wanted. Thus, the design of the kitchen was based on pictures and measurements of the parents kitchen.

However, since it had standard dimensions it will be possible to change to another kitchen if needed.

At first, the design used the cupboards to hide all the porcelain, but to not let the kitchen limit the measurements of a not yet found kitchen window, the decision was made to use open shelves, with material from the farm.

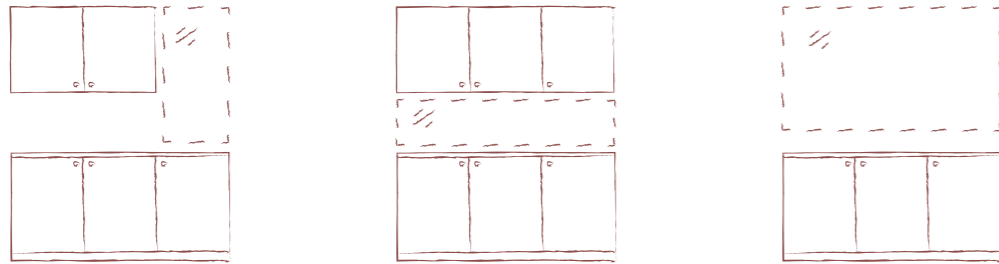

Figure 38. Different placement options for the kitchen window



Image 14. The client's parent's kitchen

ROOF DESIGN

To maximize the amount of solar panels towards the south, a lean-to roof would be the most beneficial choice. However, the client decided to put the solar panels elsewhere and go with a gable roof, since the other houses at the farm had gable roofs.

To create good space at the loft, a flat angle of the roof was necessary due to the height limitations of the Attefall regulations. Due to the angle affecting the choice of roof cover, the ultimate angle of 14 degrees was proposed. This angle provided a balance between interior height and special qualities at the loft and maintained flexibility of reuse roof cover. However, the client wanted the roof to be as steep as possible, resulting in a minor change to a 16 degree angle.

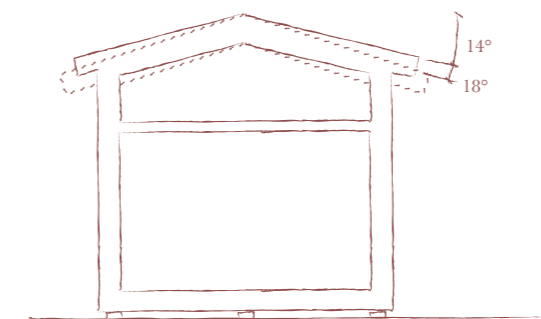

Figure 39. Section showing the impact of different roof angles

ROOF MATERIALS

Traditional clay roof tiles, commonly found at reuse retailers, need at least a gradient of 22 degrees to enable water runoff properly, avoiding the risk of frost wedging, which causes the tiles to crack.

Concrete roof tiles, the most commonly found roof tile on the reuse market, can endure a gradient of 14 degrees with maintained water run off.

Roof tiles can be unmounted and reused again. Holding high embodied energy when produced industrially they should be reused. Exceptionally old clay roof tiles may not have been produced industrially, thus not holding as much embodied energy. However, they should be reused if any beautiful patina might contribute with the aesthetic qualities.

Felt-covered roofs are not easily reused in its original intent, thus it is not available at the reuse markets. Single left-over rolls of felt are to be found but are still not reusable as a next step.

Tin roofs are less common at the reuse retailers, yet they are to be found at barns and relatively easy to demount. The cost for new roof metal sheets are quite low, which often leads to the choice of buying new ones. However, metal holds a high embodied energy and reusing it saves energy and environmental impact on the production site.

The existing buildings on the site had tin or felt-covered roofs. Thus, there was no immediate incentive to use tiles as roof cover, which made the search target for tin roofs.

WINDOWS

For good daylight conditions and to be able to ventilate the house properly, having windows on all four facades was needed. Due to a slightly unpleasant view of a distant parking lot in the west, there was a wish for a smaller window on the western facade. An elongated window with low placement in the sightline from the entrance was proposed, still creating a view of the trees in the garden. As previously described, the client wished for an outside view from the kitchen counter and an interval measurement of the kitchen window to use as reference when looking for suiting windows.

The client wanted the exterior expression of the house to be uniform and harmonize with the rest of the houses at the site, but at the same time they wanted it to feel contemporary. This lack of own determination of expression created a much appreciated freedom of design. Having specific requirements in the design affect the time spent on searching for materials as the supply on the reuse market is limited.

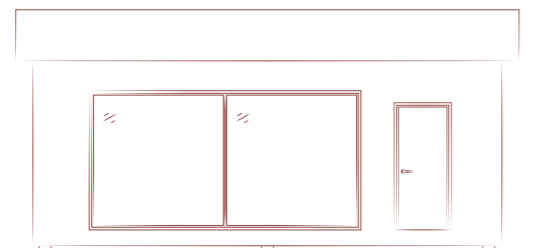

Figure 40. Windows - option nr 1.

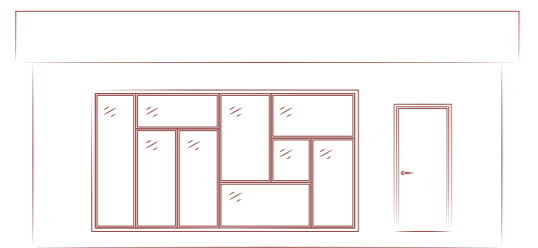

Figure 41. Windows - option nr 2.

The design process of the windows was continuously iterative due to the client changing their mind over time, especially regarding the south facing front-side of the house which sets much of the characteristics in aesthetic expression.

At first the client wanted big open windows towards the south, to erase the boundaries between outdoor and indoors during summer, yet still wanting them to be somewhat energy efficient with three glass windows. It turned out hard to find large windows on the reuse market and investigations started on what possible methods could create large partitions made out of several smaller windows.

Inspired by a study visit to the home of one of Egnahemsfabrikens coworkers, where home made wooden frames combined old window sashes quite similar to the windows of Upcycle Studios, we wanted to try creating our own frames. This could have created a unique and playful expression. However, demanding a custom made and time consuming solution. Due to the risk of condensation that the client experienced from his parents house, with windows constructed with a similar method made by a professional, they didn't want us to use that method which limited the design.



Image 15. Homemade window frames. February 27

During the iteration process of looking for a way to create a large glass partition the client changed their mind and wanted to have small openings to prevent overheating during summer and heat loss during winter. This was a drastic change from their original wish. vision, where the interior takes advantage of the seaview, was an aesthetic quality that was a shame to waste. Thus, a middle way was proposed. Three windows of the same kind and almost the same measurements and in a semi-traditional style, were found in the storages at Egnahemsfabriken. This became the final design, ending the chapter of finding the main characterizing windows. This made the process of construction proceed a little smoother.

However, the rest of the windows needed to follow the same style of southern facade, with white frames and sashes with one mullion. Designing with interval measurements allowed variation. However, some measurements were more rigid, like the bathroom window, and the availability of these windows turned out limited. Eventually all windows were found and a satisfying expression reached. However, none of the other windows were found before construction began.

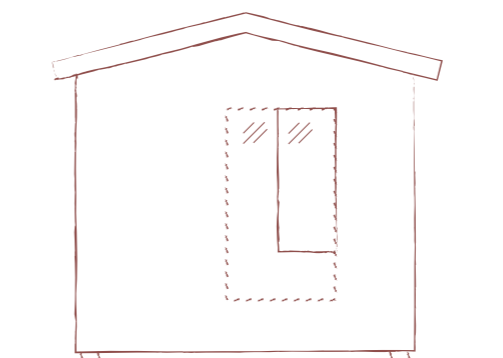

Figure 42. Interval measurement

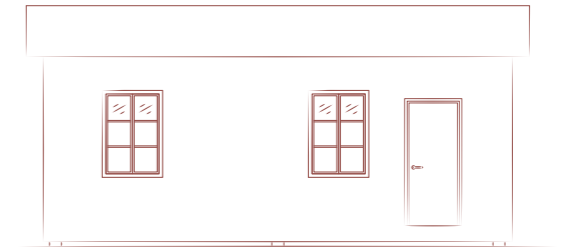

Figure 43. Windows - option nr 3.

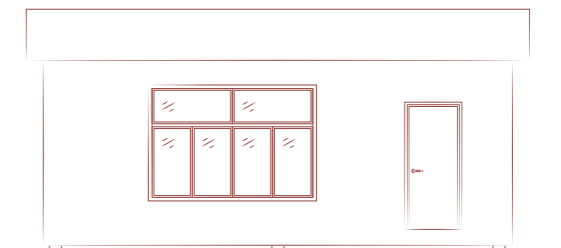

Figure 44. Windows - option nr 4.

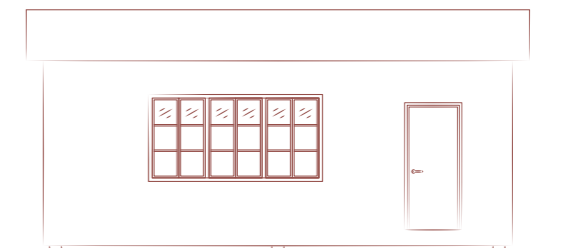

Figure 45. Windows - option nr 5.

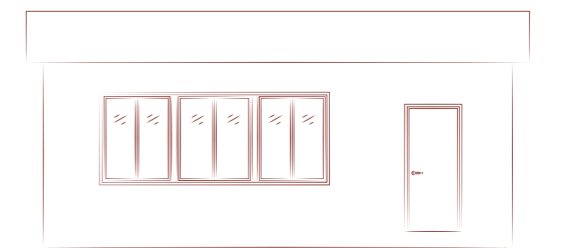

Figure 46. Windows - option nr 6. Final design.

THERMAL ENVELOPE

The question to ask oneself when planning the thermal envelope of a house is what happens when, not if, moisture gets into the structure. Different systems of facade, windshield, insulation and vapour retarder/barrier are optimized to work together to prevent mold and rot.

CHOICE OF INSULATION

Mineral wool insulation, is an umbrella term for rock wool and glass wool. Raw materials are spun to wool used as boards or as loose wool. This process is heavily energy consuming making mineral wool hold a high embodied energy.

Mineral wool cannot hold moisture, thus, there is a risk of moisture liquefying on the wooden structure causing mold and rot if entering inside the structure. Thus, the thermal envelope that includes mineral wool is a system with barriers in to prevent moisture from entering the system. In this system, fossil dense materials, such as plastics, are often used to create the barrier.

Wood fiber insulation, which is a return product from the saw milling industry, has low embodied energy due to the renewable source and less energy consuming processing of wood fibers who are bound together by small amounts of reused

polyester fibres. It is a hygroscopic material which means it can hold moisture and heat to later retract it when the air is drier. This protects the wooden structure from moisture and lets the thermal envelope breathe, enabling use of materials from renewable sources.

U-value, also known as thermal conductivity, is a measure of how well a material insulates, the lower the value, the better. Mineral wool has a bit better U-value than wood fibre insulation. However, wood fibre insulation gives the house a more even indoor climate, which is extra important in a small house.

Wood fibre insulation from Hunton has a U-value of 0.038 w/mK (Hunton, n.d.), glass wool has 0.037 w/mK (Isover, n.d.) and rock wool has 0.040 w/mK (Paroc, n.d.).

REUSE OF MINERAL WOOL

Due to the high embodied energy of mineral wool, the initial intent was to reuse mineral wool for the insulation. However, there was strong advice by the carpenter not to reuse insulation that has been used in a house previously, due to the risk of insulation absorbing smells that might not be discovered until the new house is heated. Also, it is hard to know if the insulation contains spores that might develop mold. It was also said not possible to mix different kinds of insulation due to the materials belonging to different thermal envelope systems.

USE OF NEW INSULATION

Unbroken packages of leftover insulation from construction sites would be a good alternative to reused material. However, due to the lack of time, neither the right dimensions nor sufficient quantities of mineral wool insulation were found. It was not an alternative in the project to buy new mineral wool for the missing amount, due to the high embodied energy. Quality over time and low environmental impact must be of highest priority and the decision was made to use new wood fibre insulation. Eight packages of left over wood fibre insulation was delivered from a construction site nearby, covering 145mm thickness of the 220mm insulation needed in the wooden slab. The rest was to be filled up with wood fiber wool.

POSSIBLE REUSE AND OBSTACLES

After talking to J. Elander (personal communication, March 30, 2020), district manager West at Hunton Fiber AB, we were told their vapor barrier works for all insulation types and thermal envelopes, making it is possible to mix different kinds of insulation materials in the walls (not in the floor structure or roof structure), enabling use of left over materials of insufficient amounts. However, this information was given too late in the process and there was no time to start looking for mineral wool insulation to reuse.

Quality over time and low environmental impact must be of highest priority

Also, J. Elander (personal communication, March 30, 2020), stated it possible to reuse mineral wool from an old house, but under the premises that the insulation has impaired insulation properties. Mineral wool that has been in a wall for many years does not have the same U-value as new, as the insulation collapses over the years. It is not possible to add and press new insulation on top of the old one, it creates an overly compact environment, reducing the heat resistance (Miller et al. 2005). However, it is possible to grind down the old insulation and make new wool of reused mineral or wood fibre insulation (J. Elander, personal communication, March 30, 2020). Yet, he stresses the importance of ensuring that the insulation is dry when it is removed from the wall, when damp insulation indicates a risk of mold. In addition, there is always a risk that mouse turd, or other wastage, is found in the insulation which might cause unpleasant smell.



Image 31. Leftover wood fibre insulation. March 17

WIND BARRIER

To avoid having cross brays, you can use wind boards instead of rolls of wind barrier film. It is also possible to reuse boards to a higher extent compared to films. At first, Steico Universal, wood fiber boards that were thought to be coated with wax, was to be used instead of Asfaboard, made of wood chips with a side impregnated with bitumen.

However, it turned out that the Steiko boards contain aluminium sulphate and paraffin as a bond between the layers which is not eco friendly (Steico, n.d.). Also, Steiko boards are manufactured in Poland, which will increase the embodied energy due to the transport and a higher level of fossil fuel use during manufacturing compared to Norway, where the Hunton Asfaboard is produced (Europeiska miljöbyrån, n.d.).

When mounting the asfaboards, nails had to be used due to the material being very porous and screws would break the boards.



Image 32. Leftover wood fibre insulation. April 14

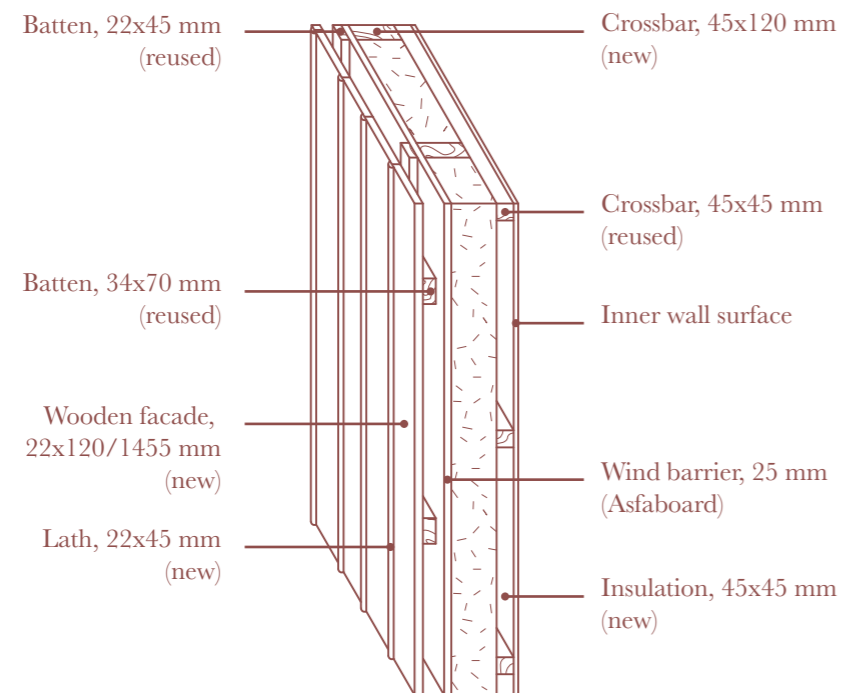

Figure 48. Detail of wall - Scale 1:20

FINAL DESIGN

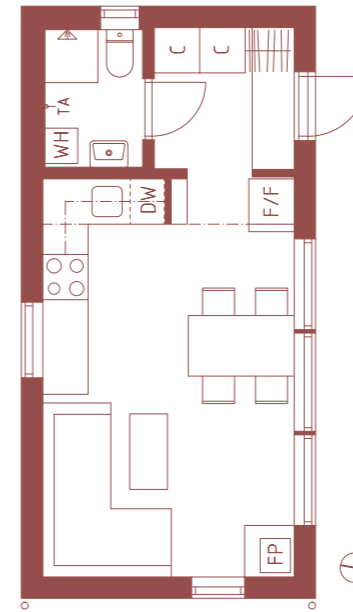

Figure 49. Entrance floor - Scale 1:200

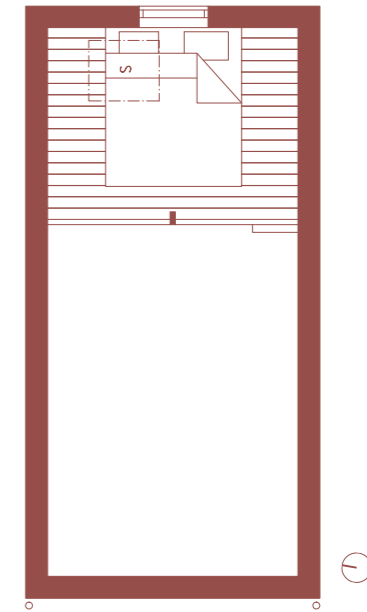

Figure 50. Loft - Scale 1:200

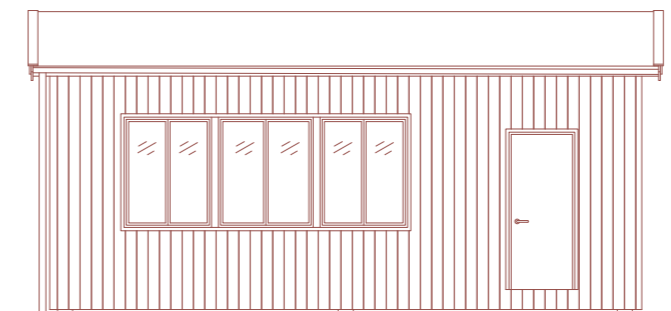

Figure 51. Facade South - Scale 1:200

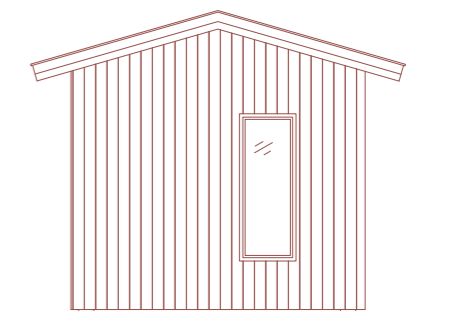

Figure 52. Facade West - Scale 1:200

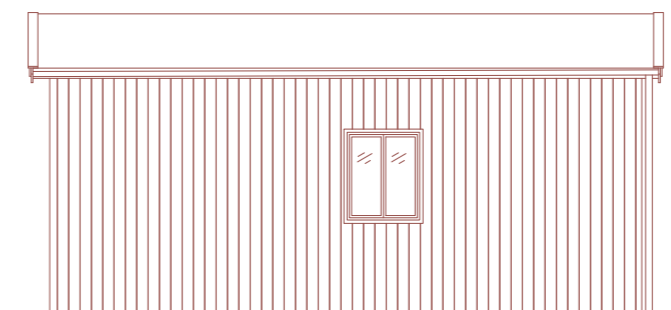

Figure 53. Facade North - Scale 1:200

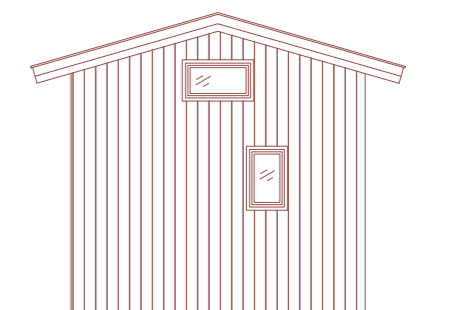

Figure 54. Facade East - Scale 1:200

Phase 3

CONSTRUCTION START

FOUNDATION

The house was built on reused concrete blocks from the garden. This made it possible to build most of the house at Egnahemsfabriken and later transport it to Väröbacka, which was logistically beneficial for the project. Not casting a concrete slab as a foundation for the house lowers the total embodied energy of the house. Also, making the house movable in the future provides a possibility to sell the house if the client no longer has a need for it on the premises or wants to take it with them if they move.



Image 16. Spirit level. March 6

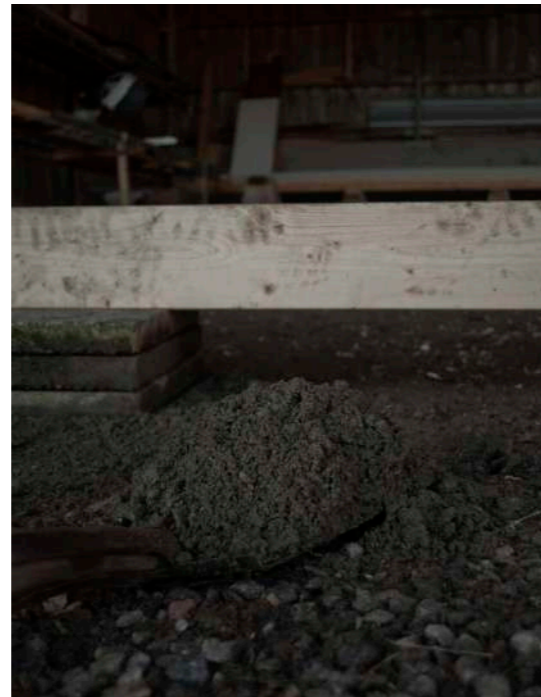

Image 17. Gravel. March 6



Image 18. The piles were grounded with gravel and sand which eased the process of making each pile perpendicular to the other. March 6

WOODEN CONSTRUCTION

To be able to move the house without it being too heavy, a wooden construction was chosen. The structure needs to be in classified wood, due to today's system with a demand of a signature of approval by a control manager.

One of the bigger construction companies in Sweden even had a policy to not give away or sell left over materials

Different contractors were contacted to see if they had left over material to sell or give away, but the time frame of the project made it hard to find left over classified wood, except what was already donated to Egnahemsfabriken from the building material supplier Derome. One of the bigger construction companies in Sweden even had a policy not to give away or sell left over materials. Due to the low embodied energy and the renewable source of wood, it was decided to use new wood for the load bearing structure to reach the legislation demand of construction safety.



Image 19. Pile of sorted reused material. March 6

The piles of leftover wood from Derome were sorted according to our current drawings, which of course took more time than to just unload a delivery of new material from Derome. Luckily, most of the wood was in good condition. However, the majority of the wood was not in the dimensions needed for the load bearing structure and was used for the non load bearing inner walls of the bathroom. Sorting the wood made us aware of the time consuming process of reuse, stressing the importance of priorities being put on reusing materials with high embodied energy and of good quality.

*Wood: -625 kg CO₂-e
(extraction, transport,
manufacturing, transport,
contruction/installation)*

Source: EPD Norge. (n.d.)

In a small house like this, the space at the loft was very important, which demanded the roof construction to be made out of a ridge beam instead of roof trusses. The ridge beam needed to be a glulam beam in order to manage the long span. To find a left over glulam beam in the right dimensions and length was not possible within the time frame and a new beam was ordered.



Image 20. Pile of unsorted reused material. March 6



Image 21. Delivery from Derome. March 6



Image 22. Delivery of new construction timber. March 6

CONSTRUCTION OF FRAMEWORK

When the floor structure was to be built, not all construction drawings were ready. This was affected by the windows yet to be found, where the only ones that were decided were the main windows on the south facade. As long as the construction was concerning the floor structure, there was time to look for the rest of the windows. The interval measures had to be used during construction.

The decision to use screws for the framework, instead of the common nail gun, proved rewarding to be able to change the framework of the walls whenever the drawings were updated, which they constantly were. It was also convenient when errors occurred, due to being first time self builders, it was easy to unscrew and fix the errors.

The planks below the floor structure, which hold up the subfloor closest to the ground, were nailed for easier disassembly in case of deconstruction. It is always a consideration whether to use nails or screws in the structure. It cannot be too time consuming to mount but at the same time it should be easy to disassemble in the future.

A house would never be turned upside down for disassembly, which means kicking the planks downwards if the floor structure would be disassembled. If screws would have been used, the kicking would rather destroy the wood.



Image 23. Start of the floor structure. March 11



Image 24. First half of the floor structure. March 11



Image 26. Assembled floor structure. March 12



Image 25. Resued wood underneath the floor structure. March 12



Image 27. Walls were built on top of the floor structure. March 16

CHANGE OF WINDOWS

Due to the iterative process, the drawings constantly changed during construction, which resulted in design errors demanding last minute changes in the structure. At first, the placement of the kitchen window was determined by the height of the countertop and the height of the kitchen cabinets. But during the design process the kitchen cabinets

were replaced by shelves, something that was forgotten when updating the construction drawings. Now, the windows in the main room all had the same lintel position except the kitchen window, which was noticed during construction and the window crossbars were moved to align the kitchen windows with the rest of the lintels.

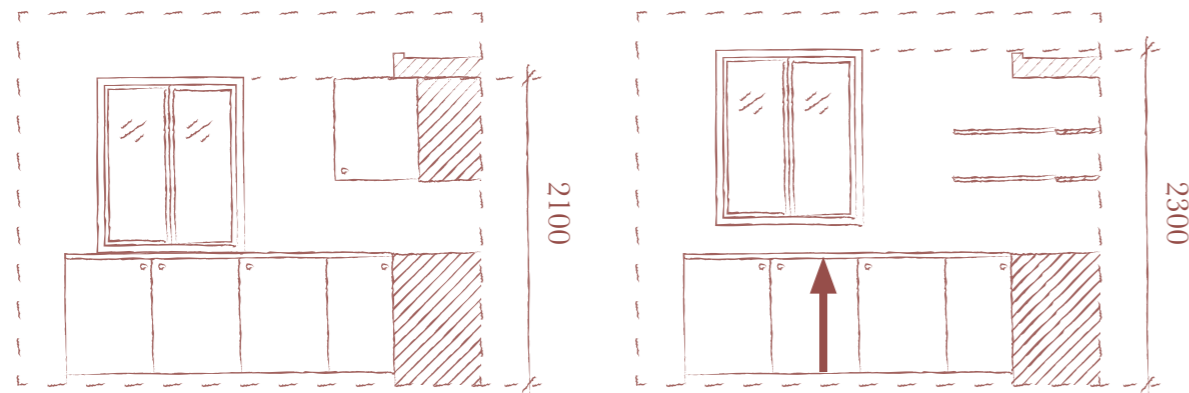

Figure 47. Moving kitchen window



Image 28. Moving a window during construction. March 16



Image 29. Moving a window during construction. March 16



Image 30. Walls were built on top of the floor structure. March 16

ASSEMBLY

Due to the low ceiling height at the current construction site, the walls could not be raised. Thus, the construction had to be moved to a site outside the protective roof.

The floor structure was placed on top of the concrete blocks and the walls were raised and assembled and joined with the floor structure. Construction of the roof could start as soon as a scaffolding was delivered to the site.

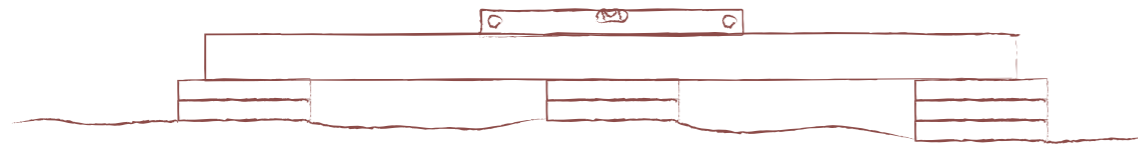

Figure 55. Construction on piers



Image 33. Once again reused concrete blocks had to be put out on the ground and weighed in. March 23



Image 34. Moving out the structure. The client was visiting the construction when moving which made the moving of the structure easier. March 24



Image 35. Temporary placement of the gables. March 24



Image 36. Raising the walls. March 24



Image 39. Delivery of reused materials. March 24



Image 37. Raising the walls. March 25



Image 38. Assembly. March 26



Images 40-42. Reused windows, bought by client. March 24



Image 43. Assembling the rest of the walls. March 25



Image 44. Assembling the rest of the walls. March 26



Image 46-47. When the ridge beam was mounted on the two gable walls and the rafters were mounted on the beam, an error was discovered. The two gables were askew, making the rafters too long for the house causing them to fly in the air. March 30



Image 45. Mounting of the unloading beam which was sawn from the ridge beam. March 30



Image 48-49. The gables were straightened up with the help of one of the carpenters and because the walls were screwed together, this could be done fairly quickly. As soon as the errors were corrected, the rafters had to be remounted. April 1

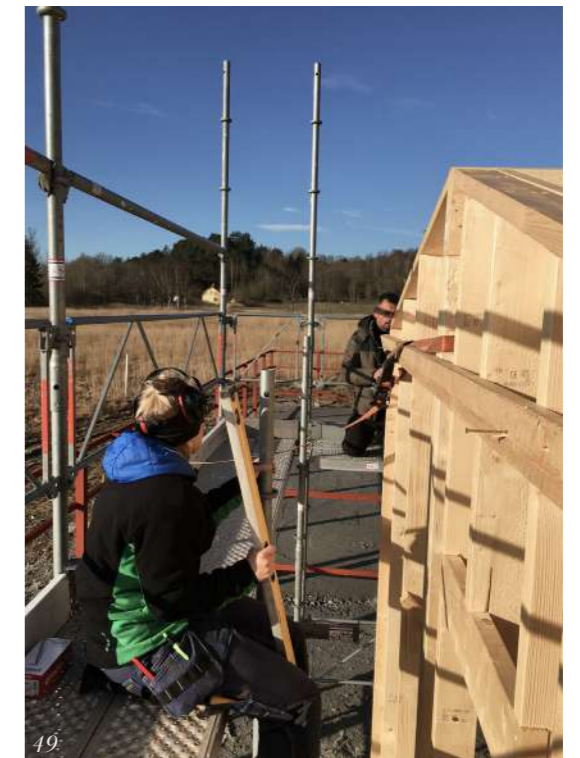

ROOF CONSTRUCTION



Image 50-51. Some tips and tricks from one of the carpenters. If several similar parts are to be constructed or mounted, it is easier to get it right by creating different templates to use. April 1



Image 53. The tongue and groove is very sensitive to wetness. A storm warning had been announced and it took 1.5 hours to secure a tarpaulin. April 1



Image 52. Mounting of tongue and groove. April 1



Image 54. Construction of the roof took several sunny days with appreciated help from a carpenter and a volunteer. April 6

CRITICAL MOMENTS

When the entire roof was covered in tongue and groove, the ridge beam flew into the air on one side. This meant that a lot of time was spent finding the error and fixing it, which meant that the roof had to be covered with a tarpaulin again. This time it went a little faster but we still had to do it in windy conditions and therefore had to secure the tarpaulin with screws into the structure.

A critical point of the time planning of the roof construction was the scaffolding, which was expensive to have on site. With that cost increasing every day, the roof had to be done quickly resulting in down prioritizing of this booklet writing time.

REASSESS PLANNING

Eventually we had to address the fact that the time we as students can spend on the construction is about to run out. The carpenter proposed that the team at Egnahemsfabriken could complete the construction of the walls and facade, which is to be made in new materials, so that the client could use our time as architects more efficiently than mounting facade material. The facade panel was nailed and not screwed, due to the labour cost of the carpenters. Also, screw heads are bigger than the heads of the nails, which would aesthetically be uglier. This way the remaining time for us could be focused on parts made of reused materials and an inventory of the metal sheets was started.



Image 55. Carpenter fixing the flying ridge beam. April 6



Image 56. Sarking membrane and wooden battens mounted on the roof. April 7



Image 57. Barge board. April 7

REUSING METAL SHEETS

The roof cover, bought through an advertisement in the local newspaper, was galvanized metal sheets with a sinus profile of 20 mm in the dimensions of 800 mm x 2445 mm.



Image 58. Print of Stockholms Galvaniseringsfabrik

The metal sheets are printed with the producer logo of Stockholms Galvaniseringsfabrik. Stockholms Galvaniseringsfabrik AB was a company established in 1895. The products produced were mostly galvanized steel plates and containers (Wikipedia, 2017). During the

first half of the 20th century the mass production made steel plates a priceworthy material and several new profiles like the sinus profile emerged in addition to the previous smooth and folded profile. During the 1970's the trapezoidal profile was created which eventually outconcurrent the sinus profile, making it typical for the first part of the 20th century in Sweden (Ekonomistål, n.d.).

In 1939 the company was introduced to the stock market and added the "AB" to the name. Eventually, plastic containers replaced steel containers and the company was closed down in 1969. The business entailed a major environmental impact which still has some influence on the water and sediment of Årstaviken, where the factory was located (Wikipedia, 2017).

METAL SHEETS

The missing letters of "AB" in the logo indicates that the sheets were produced prior to 1939. Thus, they have endured ever since and are of a very good quality.

The metal sheets had previously been mounted on an old barn. After a storm, some other sheets had been blown off and had become damaged. The owner wanted a uniformed expression, so these undamaged sheets were taken down and replaced. The sheets were

originally coated in a light grey colour that was timeworn and, in our opinion, quite ugly. Turning the sheets over, the bottom of the sheets were in good and uncoated condition and we decided to mount them upside down to get a more fresh surface.

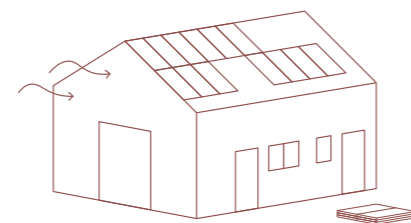

Figure 56. Barn



Image 59. Sorting of metal sheets. April 7

INVENTORY AND SORTING

Sorting the sheets, surface rust was not considered a damage but is rather a protection for the steel. Though, the parts where the rust have gone right through the steel, were sorted out due to the risk of leakage. Luckily, there was only rust at the end of some of the sheets, which was to be shortened anyway to fit the roof length.



Image 60. Sorting of metal sheets. April 7

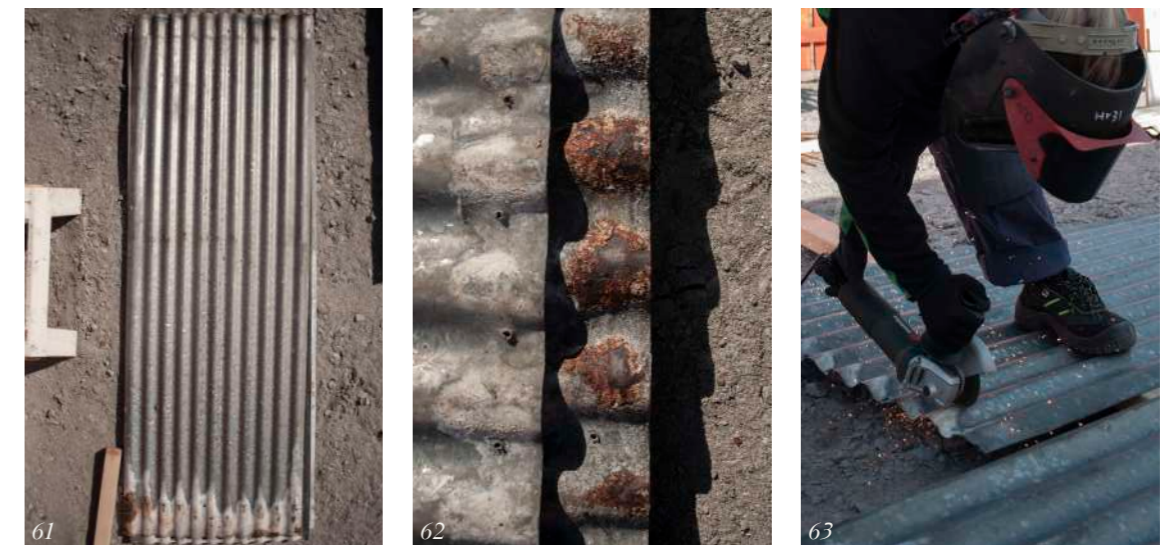

Image 61-63. Sorting of metal sheets. April 7

NEW METAL PARTS

New steel roof edges and ridge plates were ordered due to the lack of such parts to reuse. Bits and pieces were found but in different coated colours which did not fit the raw galvanized look of the metal sheets. New gutter brackets had to be mounted before the fixation of the metal sheets, thus they had to be newly purchased. This provided more time to find reused gutters.

HOLES

As the old metal sheets had been previously mounted, there were a lot of holes in them. The wooden battens on the roof were mounted in different positions to fit the existing holes, lowering the amount of new holes needed. The holes were placed on 3 rows per sheet with one row of holes on each short end and one row in the middle. However, deciding one point zero short end, measuring the distance from the short end to the middle row showed the middle row was irregularly placed between the sheets, making sorting according to four general systems of perforation necessary. The holes that need to be closed were marked and the row of holes at the rusty edges, expected to be placed at the bottom by the eaves, were cut off to fit the length of the roof.

When all the sheets were fixed it turned out that the carpenters thought the point zero of the sheets were by the eaves, but the sheets were sorted with the point zero at the ridge in mind. This caused many of the existing holes to not hit any wooden lath, already mounting all the sheets at the ridge making moving the battens a time consuming process, we were forced to drill new holes and close a few ones not hitting the lath. The old holes could, if remaining open, expose the sarking membrane underneath to UV light causing degradation over time.



Image 64. Mounting of new gutter brackets. April 14

Closing the old holes was done by punching and flattening the tulip-shaped edges created around the hole, then screwing a sheet metal screw of a larger dimension than the hole to seal it. A sheet metal screw does not need any support underneath. It adheres to the metal sheet and seals the hole with a rubber plate.

Communication is, as usual, key. The error could have been avoided if we had known that you usually start from the eaves. If it had been discovered before mounting the metal sheets on the roof, some more battens could have been mounted to create flexibility and ensure that all holes hit, which would have prevented causing more holes to close and more holes to take into account at a future reuse of the sheets.

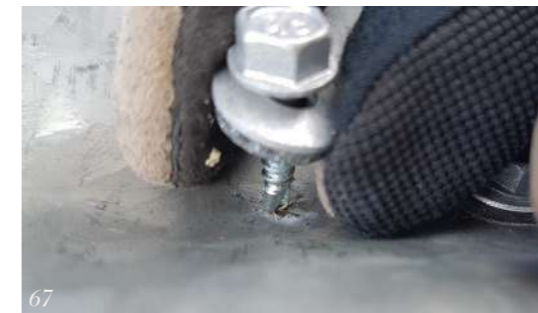

Image 65-69. Mounting of metal sheets and closing the holes. April 14

MOUNTING OF BOARDS

Until the metal parts for the roof were delivered, we started to mount the wind barriers onto the walls. But as soon as they arrived, the roof construction continued. As soon as the roof was finished and the scaffold was taken away, releasing time pressure, mounting of the asfboards continued.



Figure 57. Facades



Image 70. Mounting of Asfaboard. April 15



Image 71. Mounting of Asfaboard. April 15

FACADE MATERIAL

The house was to be situated at an old farm, with traditional Swedish houses from the beginning of the last century. According to the clients wishes of a traditional yet modern expression without shouting “shouting reuse”, the choice of facade material fell upon a wood panel with traditional round hat battens to cover the slit between the panels and for the expression to blend in. Using two different dimensions of the panels, in this case 120 mm and 145 mm, was a carpenter’s trick to create a more lively facade. The facade was decided to be made in new material, due to the low embodied energy of wood, the lack of fine quality material without nails to reuse and the labour cost of the carpenters mounting the facade.

The main house at the site was white and colors of the other houses varied between white and the traditional falu red colour, filled with Swedish heritage associations. The client wanted the house to be painted with calcimine or linseed oil paint, which are traditional paints used in Sweden. We proposed the house to be painted in traditional red calcimine colour, called Falu rödfärg, to blend in with the other complementary buildings on the site and subordinate to the main white house. Also, calcimine paint has a conserving effect on wood, making it a qualitative and sustainable choice compared to acrylic paint.

Due to the large partition of windows on the southern facade, the window casing would be rather thin and also be painted in red. This was to make the windows less articulated in the facade, for them not to take over, creating a neat expression.



72



73

Image 72-73. It turned out to be quite hard to decide what Falu red to use. The pictures show the same two colors, but they vary much depending on the light, the age and the size of the samples.

END OF PROJECT

The design of the facade was the last thing we, as students, were part of before handing over the pilot project to Egnahemsfabriken. We did not have time to be part of the mounting of either the exterior or the interior surfaces.

The interior is usually the architect's responsibility, but apart from the kitchen, the interior had to be delimited due to lack of time. However, the client was provided with consultation and thoughts on what interior material to reuse, like the bathroom porcelain and tiles.



Image 74. Wooden battens mounted on the asphalt. April 22

RETROSPECT ON BUDGET

Due to the lack of detailed budget in this project, the costs have been paid for on current account. Following costs are calculations from invoices during the construction process. However, the rest of the costs, after April 22, are unknown at the moment and it will not be possible to do a final evaluation of the budget until mid-June, when the house is transported to the client's site.

	Hours	Cost
New material - incl. transport	-	41 578 SEK
Reused material	-	18 100 SEK
Transport	-	Unknown
Ground work	-	17 237 SEK
Carpenters, EH	122 h	40 930 SEK
Architects, EH	2.5 h	1 313 SEK
Students - construction	286 h	0 SEK
Students - design & communication	175 h	0 SEK
Total:	585.5 h	119 158 SEK

SUMMARY PART 2

To test ideas of reuse and develop practical experience of how reuse affects a real design and construction process, a small house was designed and constructed in a self build context in collaboration with Egnahemsfabriken at Tjörn. The aim was to describe the crossroads where choices and priorities had to be made between reusing materials or buying new in relation to the time limits of a thesis semester and the budget, needs and wishes by a real client.

Priority was on reusing as much material as possible and achieving long-term quality and low environmental impact by using eco-friendly materials and designing for future reuse. The infrastructure for self builders that Egnahemsfabriken have created at Tjörn, and guidance by professional carpenters, was absolutely crucial for our chances to realize the pilot project within the given timeframe. Design and construction with reused materials require an iterative process. The reuse design approach was to design by market availability.

The choice of client fell upon a couple, who had a strive for an eco friendly house with reused materials and a budget of 400 000 sek which was considered having good margins. The lack of final drawings and the unknown cost of reuse products made it hard to provide a clear budget. However, the client gets the time spent by us as students for free, making the client accept the expenses being paid on current account.

To not let the reused kitchen limit the measurements of a not yet found kitchen window, the decision was made to use open shelves. Due to the angle of the roof affecting the choice of roof cover, the angle proposed provided a balance between interior height at the loft and maintained flexibility of reuse roof cover. The design process of the windows was continuously iterative. Possible methods to create large partitions made out of several smaller windows, were investigated. Three windows of the same kind, with white frames and sashes with one mullion, were found in the storages at Egnahemsfabriken, which became the final design setting the style for the rest of the windows. Designing with interval measurements allowed variation, but some windows with more rigid measurements were difficult to find.

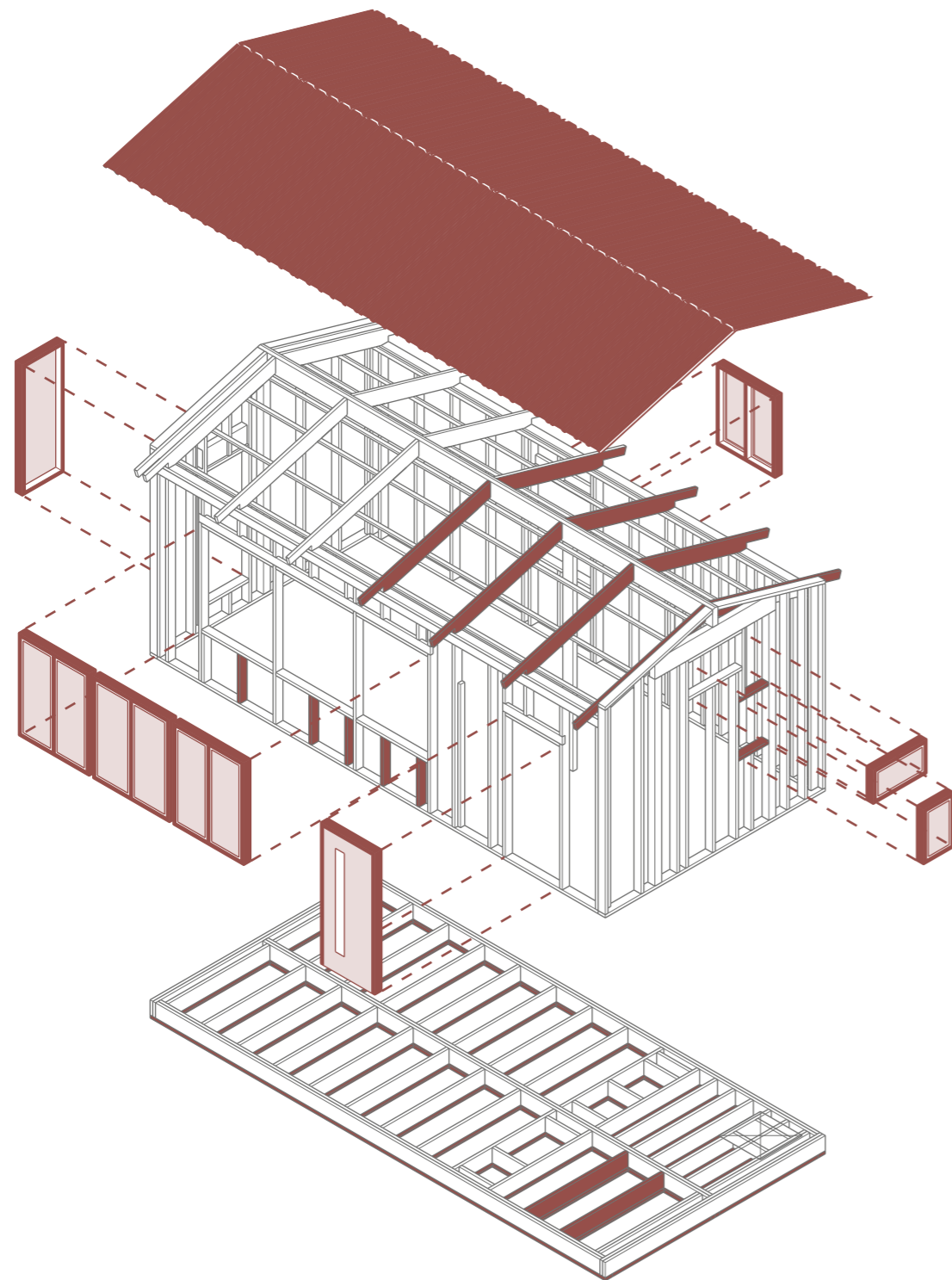

Figure 58. Summary of reused materials

Not casting a concrete slab as a foundation for the house lowers the total embodied energy of the house. Thus, the house was built on reused concrete blocks from the garden, making the house movable in the future. Due to the low embodied energy and the renewable source of wood, it was decided to use new wood for the load bearing structure. Sorting the wood made us aware of the time consuming process of reuse, stressing the importance of priorities being put on reusing materials with high embodied energy and of good quality.

Due to the high embodied energy of mineral wool, the initial intent was to reuse mineral wool for the insulation. However, there was strong advice by the carpenter not to reuse insulation that has been used in a house previously. Unbroken packages of leftover insulation from construction sites would be a good alternative. However, sufficient quantities of reusable mineral wool insulation were found. Thus, the decision was made to use new wood fibre insulation. Too late in the process, information was given that a vapor barrier working for all insulation types, would have made it possible to mix different kinds of insulation materials in the walls and enabling use of leftover materials of different types. Also, stated it was possible to reuse mineral wool from an old house. However, at this stage in the process there was no time to start looking for additional materials.

The roof cover was galvanized metal sheets with a sinus profile. Having endured since prior to 1939, they were presumed to be of very good quality. As the old metal sheets had been previously mounted, there were a lot of holes in them which were irregularly placed between the sheets, making sorting according to four general systems of perforation necessary. Some holes needed to be closed which was done by using sheet metal screws of a larger dimension, with a rubber plate as seal. Rusty edges were cut off to fit the length of the roof.

The facade was decided to be made in new material, due to the low embodied energy of wood, the lack of fine quality material without nails to reuse and the labour cost of the carpenters mounting the facade. The design of the facade was the last thing we, as students, were part of before handing over the pilot project to Egnahemsfabriken. The interior had to be delimited due to lack of time. However, the client was provided with consultation on what interior material to reuse.

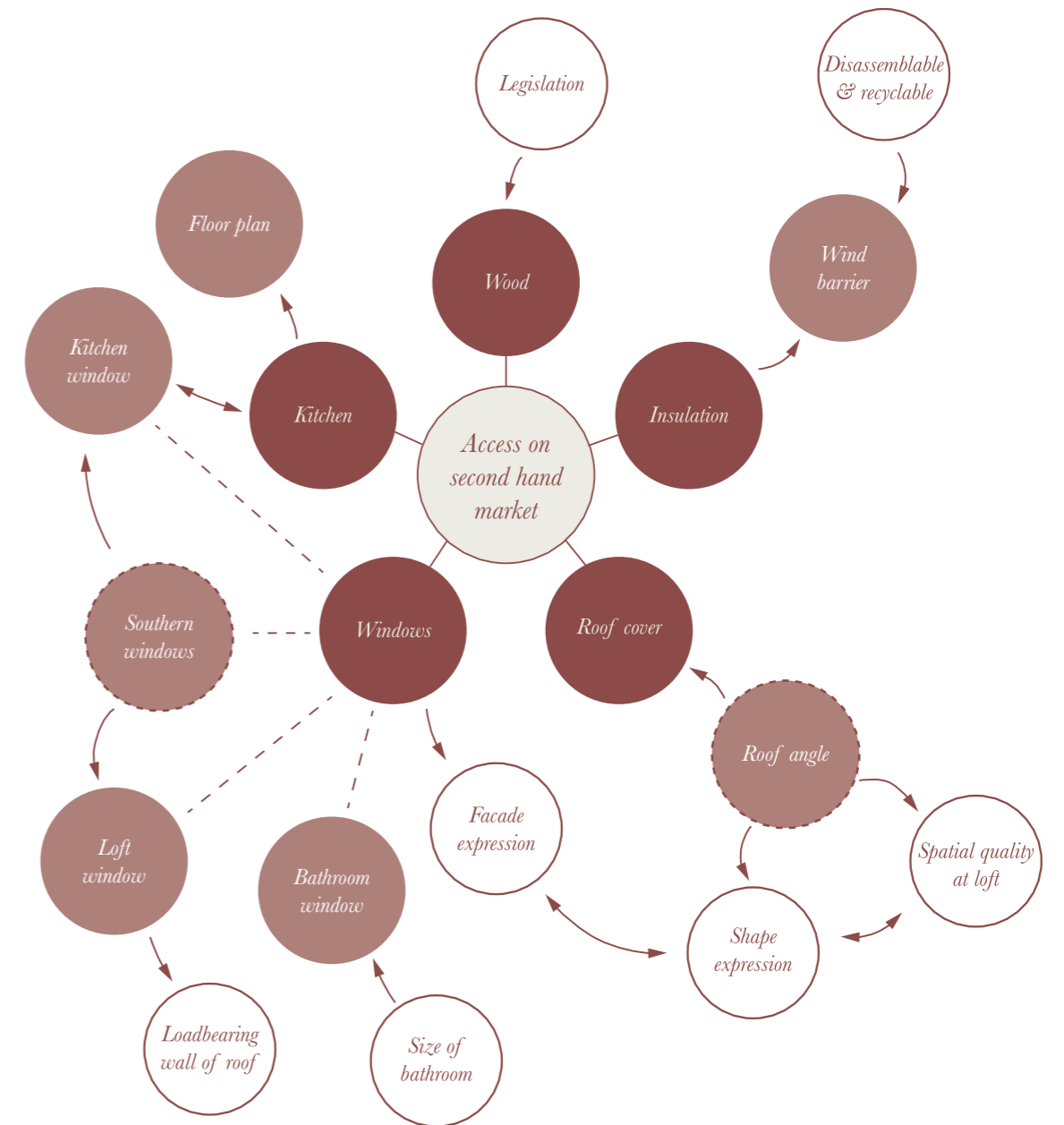

Figure 59. Diagram showing how the access to reused materials on the second hand market has affected the design process and what parts of the design affected each other

Part 3

Filling the gap

Reflections are made of how Part 1 and part 2 inform each other. The small scale of the pilot project has an impact on the design process, however, large scale buildings have other and often greater challenges when it comes to implementing reuse. Thus, part 3 reflects on how the experience from the small scale pilot project can be implemented on a larger scale.

REFLECTIONS ON THE REUSE DESIGN PROCESS

PLANNING & MANAGEMENT

Reuse projects require more time due to the lack of an efficient logistical supply system for reuse products and a need for an iterative design process caused by the many uncertainties when working with reuse. Thus, planning for this extra time is crucial for a reuse project to succeed. During the pilot project, ideas of reuse were tested in a real construction process with good access to the infrastructure needed in terms of storage, tutoring and construction site. Yet, the project did not reach all the way to the intention of constructing a finished house made of 100% reused materials.

The most pressing challenge during the pilot project was the accelerated process, occurring due to the time limits of a thesis semester, in combination with the delays caused by finding a new client after the start of the project process. Without a client, and therefore a lack of knowledge on what amounts of materials or style is needed, it was not possible to start the process of evaluating material access. Of course this is a circumstance unique for the pilot project of this thesis. Usually, the starting point is opposite, with a client needing to engage an architect.

Under better circumstances, the collaboration with Egnahemsfabriken and a client would have been established earlier, preferably during the fall of 2019. This would have made an early conceptual design possible, creating a better overview of the required reused and new materials and making the planning of the construction conducted under calmer conditions. The accelerated process gave little time to collect reuse materials and to research for alternatives according to the project priorities. With proper time management, more materials could have come from reused or left-over sources instead of new.

A building permit was not needed in the pilot project due to the regulations in this small scale, which made the design flexible during the circumstances. However, a milestone like a building permit could have helped create a structure for the process and a natural breathing space to search for reuse materials and to reevaluate choices made.

The iterative process needed, creates a challenging chain of consequences where previous decisions constantly need to be reevaluated and changed according to current material availability. Also, the combination of not only being design project managers, but being inexperienced construction project managers and carpenters as well, showed to be more energy consuming and demanding than expected. However, the challenges that come with reuse creates an interesting design process where the architects can contribute with their ability to maintain a holistic view of a project. Also, engaging in the construction process has provided invaluable insight into the possibilities of collaboration and knowledge sharing between professions is key to succeed with reuse projects, and the kind of understanding and experience collectable from a pilot project is exactly what is needed for architects to develop in reuse design.

REUSE AVAILABILITY

The day-to-day occurrence of reuse materials in the small and unconnected recycling handlers in the region makes it hard to get an overview of the available materials. It is time consuming to drive around to the handlers ever so often. Throughout the pilot project of this thesis, the material collected has been found through web sites such as Blocket and Marketplace where it is easier to get an overview of today's accessible materials. Also, the client was very helpful in searching for materials we requested, advertising in the local newspaper and delivering it to the construction site. However, our time as students and as self-builders was free, making sourcing materials from a variety of sources work for small scale projects of private use. For a commercial project in the current system of fragmented reuse supply, it is not feasible for architects and contractors to look for and collect materials due to the high hourly cost. Labor costs are taxed higher than industrial production, which makes reuse disadvantageous in comparison to new materials.

Another reflection of the construction process is that it is highly recommended to collect all needed materials before the construction starts to be able to properly plan the construction and avoid interruptions caused by the need to search for reuse materials. Taking reuse to a larger scale, where the logistics and planning is a much bigger challenge, this would be crucial, even meaning all the difference, for the possibilities to go through with a reuse project or not.

The experience from the small scale pilot project stresses the conclusion of Josefsson (2019) stating that there is a need for a large-scale, organized database to create an overview of collected materials to reuse. To make it even more efficient, the same database should also include buildings that are about to be deconstructed and inventories made of such buildings, making coordination and organization of reuse in building projects more efficient.

As the aviation sector has sites as skyscanner and flygresor.se, the construction sector could have corresponding sites creating an overview of the reuse available from different sources, making it as easy to order reuse products as ordering new ones.

B. Johansson (personal communication, January 29, 2020) develops an interesting thought on the cities need to find long-term solutions for the increasing demand for reuse materials. It would benefit construction with reuse if the city would plan for factories, storage centers and material stocks inside the city boundaries, which would make construction sites less dependent on “just in time”-deliveries. The lack of such storage possibilities makes it hard to circulate materials locally today. Also, this would make citizens better connected with manufacturing and craft which would facilitate increased refurbishment and reuse. “A common and local logistics centre in the city for contractors would be a very interesting concept to benefit reuse” - B. Johansson (personal communication, January 29, 2020)

LARGE QUANTITIES OF MATERIALS

One of the challenges of reuse on a large scale is the difficulty to find large quantities of exterior materials for the ever growing scale of modern buildings. However, looking at Sweden’s latest housing exhibition, Vallastaden in 2017, one can expect an ongoing shift in design expression beneficial for reuse. With blocks for mixed use and housing, divided into smaller plots of land to welcome a variety of different developers, the aim is to create a variation in the facade expression for the bypasser. One can have opinions on whether the result was appealing or not, in our opinion creating a lack of coherence by crazy individualistic facades. However, it indicates an emerging desire for small scale expression and variation in the architecture of facades in the cityscape, which could facilitate reuse.

As reuse projects are quite new in the Swedish construction industry, the need for large amounts of similar materials required in large scale construction, makes the effectiveness in matching a scheduled deconstruction of a certain building increased.

COST

One is constantly faced with the temptation of buying new materials when time is limited and there is easy access to new materials on demand. However, the time is limited in all projects even though planning in general is based on the timeframes around new materials. Thus, it is not fair to compare the cost of hours spent by first time self builders with the cost of professionals.

When self builders build for their own purpose they can make their own choices and evaluate what is worth and not worth spending time reusing. Even if our time as students was for free and that we approached the design and construction of this project in a self build context, we will come to work with reuse from a commercial perspective in our future profession as architects. Thus, insight and underlying evaluation of what is worth reusing or not has been gained with that perspective in mind.

Aiming for 100 % reused materials in timber-framed structures, with low embodied energy, is not desirable in commercial projects. However, the structure usually has a high impact on the environmental performance of the building, especially in concrete structures, which might make reuse a more stressed factor of consideration in those cases. Working with reuse projects constantly creates crossroads where priorities and design decisions have to be made based on the relation between quality, aesthetics and environmental gains on one hand, and cost of labor time on the other. Materials with low embodied energy in combination with low quality, such as wooden facade material, tongue and groove are not worth reusing in commercial projects. Piles of wooden materials from old structures often contain a lot of nails which will demand time consuming cleansing in order not to break the saw blades when later processing the wood, which is interrupting the construction, thus, costly and time consuming. The material might be for free, or low cost, but the time spent can make the total cost for reused material exceed the cost of new materials for little environmental benefit. As presented in Part 1, it is never worth spending a lot of time reusing low embodied energy products unless they have a very high cultural heritage value.

LARGE QUANTITIES OF MATERIALS

Today, during times of increased awareness of climate change, there is an increased interest in reuse within the construction industry, but there is not yet a system that supports reuse which makes reuse processes complicated and time consuming. In the construction industry, where short term financial gains are always prioritized higher than values of quality, aesthetics and environmental impact, there is a lack of incentives to create the logistical support system that is needed for reuse to be feasible on a large scale. A downward spiral is evident. However, the market providing the systems is regulated by demand and businesses are creative when they see an opportunity. When the demand increases, entrepreneurs will find ways to provide the necessary structure that supports reuse and by designing with reused materials, the architect can contribute to that increasing demand. A logistical system for reuse will make the reuse design and construction process less complicated, less time consuming and thereby cheaper, reversing the downward spiral. A higher valuation of factors lowering the emissions, such as reuse of materials, by legislation and global policies is also an important instrument to guide the market towards reuse.

However, in the beginning, for architects able to realize reuse projects, their own systems must be created through collaboration with like minded suppliers and businesses. Since everything is project specific when it comes to reuse and the context of the project creates different prerequisites, it is difficult to define a certain design methodology for reuse processes. However, by looking at offices like Lendager Group, Vandkunsten and Superuse Studios, a lot of inspiration and knowledge can be collected.

The design and construction project implemented in this thesis, demonstrates the importance of architects starting their own learning process by engaging in pilot projects. To gain experience on how reuse works in practice, starting on a small scale is recommended by B. Johansson (Personal communication January 26, 2020). However, starting on a small scale doesn't necessarily mean one has to start with a small house as in this thesis. It can instead be to try reusing one single material in the building or implement reuse in a small part of a large building. Even if the small scale reuse is only 1% of the construction, the value of that percentage might be huge for future reuse, putting thoughts into motion, establishing collaborations and disarms the notion that reuse is too complicated.

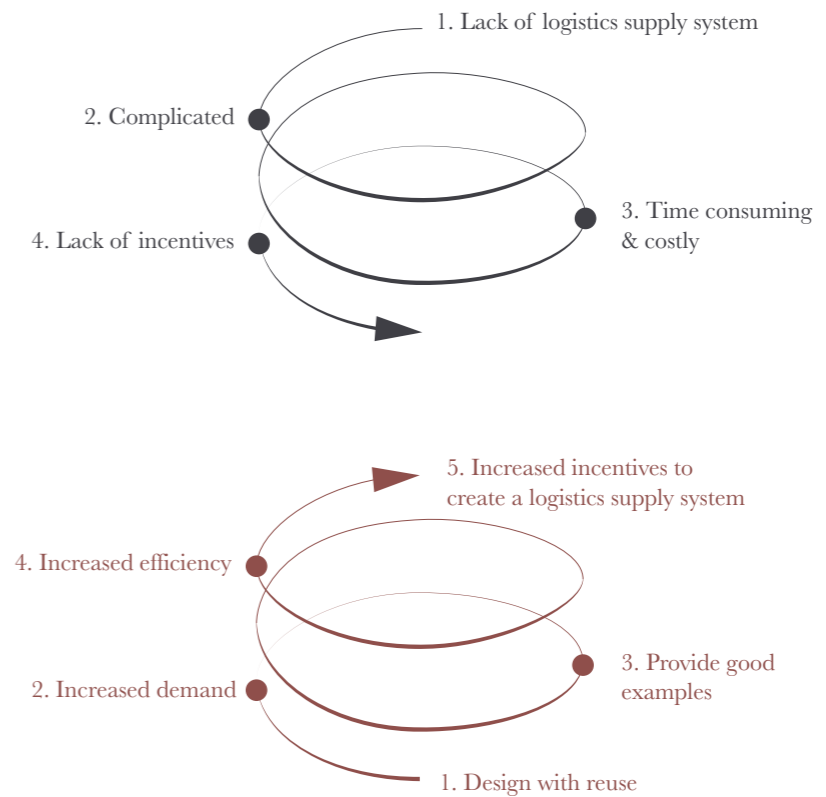

Figure 60. The vicious circle of reuse obstacles

*Discussion &
conclusion*

With departure in current global problems, the thesis aspires to consider reusing materials as one of the solutions to decrease environmental impact of today's wasteful construction industry. Through research and implementing a real design and construction project, the aim of this thesis is to discuss what aspects affect the process of reusing materials, describe perspectives on the current and future status of reuse in Sweden and contribute with experience transfer on how working with reused materials affect the design process.

This thesis strived to answer two main questions:

1. In what way can architects contribute to an increase of reuse projects in Sweden?

Through interviews and literature studies, this thesis collects knowledge from professionals within the architectural field of today's construction industry in Sweden, describing what aspects affect the opportunities to reuse, what challenges exist and what they see as likely measures to increase reuse.

By implementing a real design and construction project, to gain experience on how reuse works in practice beyond conceptual ideas, this thesis demonstrates the importance of architects starting their own learning process by engaging in pilot projects and taking a more active part in construction.

Also, the thesis shows that architects must become increasingly flexible in their design and adapt to the iterative design process needed when working with reused materials, designing with what is available within the context of the project. Architects can contribute to making reuse feasible by increasing their knowledge on material content, quality and environmental impact, to be able to balance cost, quality and aesthetics and make priorities of what material is worth reusing or not in commercial projects.

Today, during times of increased awareness of climate change, there is an increased interest within the construction industry in how to reuse materials to decrease the environmental impact of the construction industry. This creates a possibility to establish cross disciplinary collaborations for reuse to become the new "business as usual".

However, there is not yet a logistics system that supports reuse. By designing with reused materials, the architect can contribute to an increasing demand which will create incentives for a logistical system facilitating reuse, making it less complicated, less time consuming and thereby cheaper, reversing the present downward spiral. However, in the beginning, for architects to be able to realize reuse projects, their own systems must be created by establishing collaboration with like minded suppliers and businesses.

2. What effects do working with reused materials have on the architectural design process?

Through implementation of a real design and construction project, this thesis tests ideas of reuse and develops practical experience beyond conceptual conceptions of how reuse affects the architects design process. Through documentation, crossroads are described, where priorities were made between reusing materials or buying new in relation to the time limits of a thesis semester and the budget, needs and wishes of a real client. The findings of how working with reuse affects the architects design process are reflected upon in relation to the small scale of the self build project as well as on a larger commercial scale.

Engaging in a construction process during the thesis provides invaluable understanding of the importance of collaboration and knowledge sharing between professions, which is key to succeed with reuse projects. Statements which were also stressed by the professionals interviewed during the thesis.

Reuse projects require more time due to the lack of an efficient logistical supply system for reuse products. Also, the many uncertainties when working with reuse demands an iterative design process, which creates a challenging chain of consequences where previous decisions constantly need to be reevaluated and changed according to current material availability. Thus, planning for this extra time is crucial for a reuse project to succeed.

A slightly unexpected realization during the thesis is the fact that 100% reuse is rarely desirable nor possible in commercial constructions. Thus, increased reflection on material qualities and properties are required during the design process, to find the balance between labour cost and quality, aesthetic value and environmental impact of new and reused materials. However, that is beneficial for reaching sustainability in all constructions, reused or not.

PERSONAL REFLECTION

In this thesis, we have tried to find our way in the jungle of truths and perspectives in the construction industry. Overwhelmed by the complexity of the subject we have chosen to investigate during this thesis, we are painfully aware that we have only scratched the surface of the subject of reuse in the construction industry.

Even if we both have made internships at architecture firms, we are humble towards the fact that we, as students, have limited knowledge on design and construction processes with new materials in practice. Thus, it is sometimes hard to compare the processes of new materials with the process of reused materials. This has by far been the most valuable semester at Chalmers. We are proud of our project, eager to keep learning about reuse and the skills and craft required by the profession that we are now entering.

Physical movement and daylight is health promoting but today the architectural profession is based on indoor desk work in front of computers. By doing the pilot project as self-builders, we have been outside engaged in physical work during large parts of the semester, feeling more energized and creative compared to previous semesters indoors at Chalmers. By attending the construction site the architect's knowledge can be broadened, important relationships can be established and the health of people in the profession can increase.

It is easy to fall in the trap of becoming pessimistic when the idealized world at school falls apart under financial circumstances of reality. However, apart from all the possibilities we have discovered and everything we have learned during this semester, we see a lot of will and commitment around us by individuals and companies trying to find solutions for a sustainable construction industry. It proves that change is happening, which keeps us optimistic.

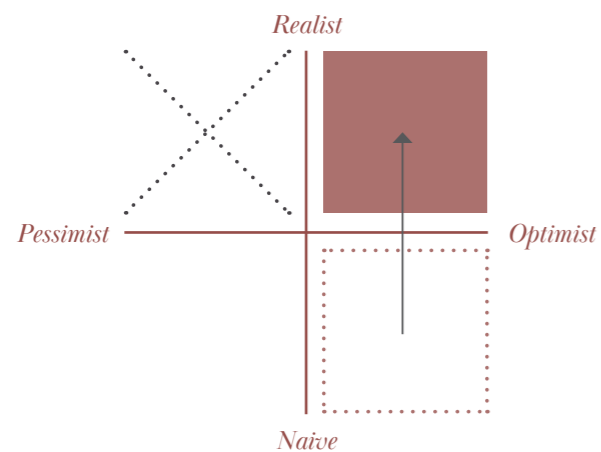

Image 75. Mounting of the tongue and groove. April 1

REFERENCE LIST

- AGC-glass. (n.d.). Our environmental impact. Retrieved 2020 May 6 from <https://www.agc-glass.eu/en/sustainability/environmental-achievements/environmental-impact>
- Azari, R. (2019). *Sustainable Construction Technologies Life-Cycle Assessment*. Oxford: Butterworth-Heinemann.
- Ban, S. (2013, May). Emergency shelters made from paper [Video file]. Retrieved 2020 May 6 from https://www.ted.com/talks/shigeru_ban_emergency_shelters_made_from_paper
- Berge, B. (2009). *The ecology of building materials* (2. ed.). Oxford: Elsevier Ltd.
- Bismark, J. (2020). Återbruk och återbrukbarhet inom byggbranschen: En studie av hinder och utvecklingsmöjligheter med fokus på korslimmat trä (master's thesis, Lunds Tekniska Högskola, Institutionen för Teknik och samhälle).
- Boverket. (2020). Detta gäller för attefallshus. Retrieved 2020 May 4 from <https://www.boverket.se/sv/byggande/bygga-nytt-om-eller-till/bygga-utan-bygglov/attefallshus/>
- Brander, M./Ecometrica. (2012). Greenhouse Gases, CO₂, CO₂e, and Carbon: What Do All These Terms Mean? Retrieved 2020 April 24 from: <https://ecometrica.com/assets/GHGs-CO2-CO2e-and-Carbon-What-Do-These-Mean-v2.1.pdf>
- BusinessDictionary. (n.d.). Waste stream. Retrieved 2020 April 13 from <http://www.businessdictionary.com/definition/waste-stream.html>
- Byggherrarna Sverige AB. (2018). Partnering tillämpningsföreskrift: Tillämpningsföreskrifter för Byggherrarnas kontraktstyp totalentreprenad med partnering. Byggherrarna i Sverige AB. Retrieved 2020 May 4 from <https://www.byggherre.se/library/2421/tillaempningsfoereskrift-partnering-abt-180322.pdf>
- Chalmers. (2020). The circular kitchen. Retrieved 2020 May 9 from <https://www.chalmers.se/en/projects/Pages/The-circular-kitchen.aspx>
- Egnahemsfabriken. (2018) Vad är egnahemsfabriken?. Retrieved 2020 May 26 from <https://www.egnahemsfabriken.se/>
- Ellen MacArthur Foundation. (2015). Towards a circular economy: Business rationale for an accelerated transition. Retrieved 2020 April 23 from https://www.ellenmacarthurfoundation.org/assets/downloads/TCE_Ellen-MacArthur-Foundation_9-Dec-2015.pdf
- Ellen MacArthur Foundation. (2013). Towards the circular economy: Economic and business rationale for an accelerated transition. Retrieved 2020 April 23 from <https://www.ellenmacarthurfoundation.org/assets/downloads/publications/Ellen-MacArthur-Foundation-Towards-the-Circular-Economy-vol.1.pdf>
- Ekonomistål. (n.d.). Plåtens historia. Retrieved 2020 April 10 from <http://www.ekonomistal.se/platens-historia>
- EPA. (n.d.). Reducing and reusing basics. Retrieved 2020 April 27 from <https://www.epa.gov/recycle/reducing-and-reusing-basics>
- EPD Norge. (n.d.). Environmental product declaration. Retrieved 2020 May 1 from https://www.epd-norge.no/getfile.php/1311690-1575284360/EPDer/Byggevarer/Heltreprodukter/NEPD-1937-857_Fingerskjott-trelast---konstruksjonsvirke.pdf
- European Commission. (2019). Construction and Demolition Waste (CDW). Retrieved 2020 April 13 from https://ec.europa.eu/environment/waste/construction_demolition.htm
- European Commission. (2014). Communication from the commission to the European Parliament, the Council, the European economic and social committee and the Committee of the regions on resource efficiency opportunities in the building sector. Retrieved 2020 April 27 from <https://ec.europa.eu/environment/eussd/pdf/SustainableBuildingsCommunication.pdf>
- European Commission. (2019). Embodied energy. Retrieved 2020 April 24 from https://ec.europa.eu/energy/eu-buildings-factsheets-topics-tree/embodied-energy_en?redir=1
- European Commission. (2014). Resource efficiency in the building sector. Retrieved 2020 April 27 from <https://ec.europa.eu/environment/eussd/pdf/Resource%20efficiency%20in%20the%20building%20sector.pdf>
- European Commission. (2019). Waste prevention and management. Retrieved 2020 April 13 from https://ec.europa.eu/environment/green-growth/waste-prevention-and-management/index_en.htm
- Europeiska miljöbyrån. (n.d.). Energi i Europa: så ser det ut idag. Retrieved 2020 May 10 from <https://www.eea.europa.eu/sv/miljosignaler/miljosignaler-2017-europas-framtida-energiforsorjning/artiklar/energi-i-europa-sa-ser>
- Fröst, P. (1995). *Handbok för återvinnare: om återvinning och återbruk av byggnadsmaterial*. Lund
- Göteborgs Stad. (2020). Dags att bygga och riva cirkulärt!: Slutrapport från projektet Upphandlingskrav för cirkulära flöden i bygg- och rivningsprocessen. Göteborgs Stad. Retrieved 2020 January 28 from <https://goteborg.se/wps/wcm/connect/d0600675-8e9c-4522-9984-4783c65d9a07/Slutrapport+Upphandlingskrav+f%C3%B6r+cirkul%C3%A4ra+fl%C3%B6den+i+bygg+och+rivningsprocessen.pdf?MOD=AJPERES>
- Johansson, B. (2018). Arkitektens Återbruksmetodik. Retrieved 2020 January 27 from https://ccbuild.se/content/uploads/2019/03/WRL_Arkitektens_%C3%A5terbruksmetodik_2018.pdf
- Josefsson, T. (2019). Form follows availability: The reuse revolution (Master's thesis, Chalmers University of Technology, Department of Architecture and Civil Engineering). Retrieved November 20 from <https://odr.chalmers.se/handle/20.500.12380/257024>
- Hett Groene Brein. (n.d.). How is a circular economy different from a linear economy?. Retrieved 2020 April 29 from <https://kenniskaarten.hetgroenebrein.nl/en/knowledge-map-circular-economy/how-is-a-circular-economy-different-from-a-linear-economy/>
- Lendager, A and Lysgaard Vind, D (2018). *A changemaker's guide to the future*. Denmark: Lendager Group.
- Lendager Group. (n.d.). Lendager UP. Retrieved 2020 May 7 from <https://lendager.com/en/upcycle-en/>
- Lloyd Thomas, K. (2007). *Material Matters Architecture and material practice*. New York: Routledge.
- Lyngsgaard, S., Guldager Jorgensen, K. (2013). *Cradle to Cradle in the built environment*. Copenhagen: 3XN GXN.
- Merriam Webster. (n.d.). Upcycle. Retrieved 2020 April 22 from (<https://www.merriam-webster.com/dictionary/upcycle>)
- Miller, M.R., Miller, R. & Leger, E. (2005). *Complete Building Construction* (5th Edition). Indianapolis: John Wiley & Sons.
- Naturvårdsverket. (2018). Avfall i Sverige 2016. Retrieved 2020 April 17 from: https://www.scb.se/contentassets/842c4b4c880247b28fad6fef853a0526/mi0305_2016a01_br_misambr1801.pdf
- RISE. (n.d.). Cement and concrete. Retrieved 2020 May 6 from <https://www.ri.se/en/what-we-do/our-areas/cement-and-concrete>
- Rose, C. and Stegemann, J. (2018). From waste management to component management in the construction industry. *Sustainability*, (10), p. 14. doi:10.3390

Roth, L. (2005). Reuse of construction materials: Environmental performance and assessment methodology (Dissertation, Linköpings Universitet, Linköping). Retrieved 2020 January 20 from <https://www.diva-portal.org/smash/get/diva2:21001/FULLTEXT01.pdf>

Röstlund, I. (2017). FORM FOLLOWS MATERIAL: design with local resources (Master's thesis, Chalmers University of Technology, Department of Architecture and Civil Engineering). Retrieved 2020 January 16 from <https://odr.chalmers.se/handle/20.500.12380/252144>

SCB. (2018). Branscher med mest uppkommet farligt avfall. Retrieved 2020 April 17 from: <https://www.scb.se/hitta-statistik/statistik-efter-amne/miljo/avfall/avfall-uppkommet-och-behandlat/pong/tabell-och-diagram/branscher-med-mest-uppkommet-farligt-avfall/>

SCB. (2018). Uppkommet avfall. Retrieved 2020 April 17 from: <https://www.scb.se/hitta-statistik/statistik-efter-amne/miljo/avfall/avfall-uppkommet-och-behandlat/pong/tabell-och-diagram/uppkommet-avfall/>

Souza, E. (2020). Embodied Energy in Building Materials: What it is and How to Calculate It. Retrieved 2020 April 28 from <https://www.archdaily.com/931249/embodied-energy-in-building-materials-what-it-is-and-how-to-calculate-it/>

Persson-Engberg, J. (1999). Rivningshandboken: planering, demonteringsmetoder, verktyg. Stockholm: Svensk Byggtjänst.

Thormark, C. (2007). Energy and Resources, Material Choice and Recycling Potential in Low Energy Buildings. Sustainable Technology, Lisbon

Tidningen Byggmaterial. (2020). Förbrukat byggmaterial får nytt liv. Retrieved 2020 May 6 from <https://www.tidningenbyggmaterial.se/nyheter/e/151/forbrukat-byggmaterial-far-nytt-liv/>

United Nations. (2015). Sustainable development goals. Retrieved 2020 April 16 from <https://www.un.org/sustainabledevelopment/sustainable-development-goals/>

UN Environment. (2018). Global Status Report 2018. Retrieved 2020 April 27 from <https://www.unenvironment.org/resources/report/global-status-report-2018>

Urban Next. (n.d.) Upcycled Studios: A sustainable solution. Retrieved 2020 May 11 from <https://urbannext.net/upcycled-studios/>

White Arkitekter. (2020, April, 15). Re-use: Vad behövs för att återbruk ska bli vår nya standard? [Video file]. Retrieved April 30 2020 from <https://whitearkitekter.com/se/news/webbinarium-22-april-re-use-vad-behovs-for-att-aterbruk-ska-bli-var-nya-standard/>

Wikipedia. (2017). Stockholms Galvaniseringsfabrik. Retrieved 2020 April 10 from https://sv.wikipedia.org/wiki/Stockholms_Galvaniseringsfabrik

YourHome. (2013). Embodied energy. Retrieved 2020 April 28 from <https://www.yourhome.gov.au/materials/embodied-energy>

IMAGE AND FIGURE REFERENCE

All images and figures are authors' own, except:

Figure 1. Egnahemsfabriken (2020)

Figure 7. Design process with reuse and local materials. Form Follows Material by Röstlund (2017, p. 85)

Figure 8. Arkitektens Återbruksmetodik. Johansson (2018, p. 10)

Image 6. Townhouses in Svartlamon. Photo by Nøysom arkitekter (n.d.)

LIST OF INTERVIEWEES

A.-M. Blixt (personal communication, February 11, 2020)
Anna-Maria Blixt, architect engaged in developing reuse projects at Link Arkitektur in Gothenburg.

A. Franker (personal communication, February 11, 2020)
Anton Franker, reuse consultant in Gothenburg.

B. Johansson (personal communication, January 29, 2020)
Björn Johansson, architect and development manager of transformation and circularity at White Architects in Stockholm and author of the report Arkitektens återbruksmetodik (2018).

C. Olsson (personal communication, February 12, 2020)
Christian Olsson, window restoration specialist of cultural heritage buildings at Tvåtumfyra Byggnads AB. craftsman of windows, working with refurbishment of windows in heritage buildings.

J. Helmfridsson (personal communication, February 12, 2020)
John Helmfridsson, architect and sustainability specialist at Wingårdhs and tutor of this thesis.

J. Elander at Hunton (personal communication, March 30, 2020)
Joakim Elander, district manager West at Hunton Fiber AB.

L. Conradi (personal communication, February 3, 2020)
Laura Conradi, architect of renovation and transformation projects at White Architects in Gothenburg.

APPENDIX I

Final drawings

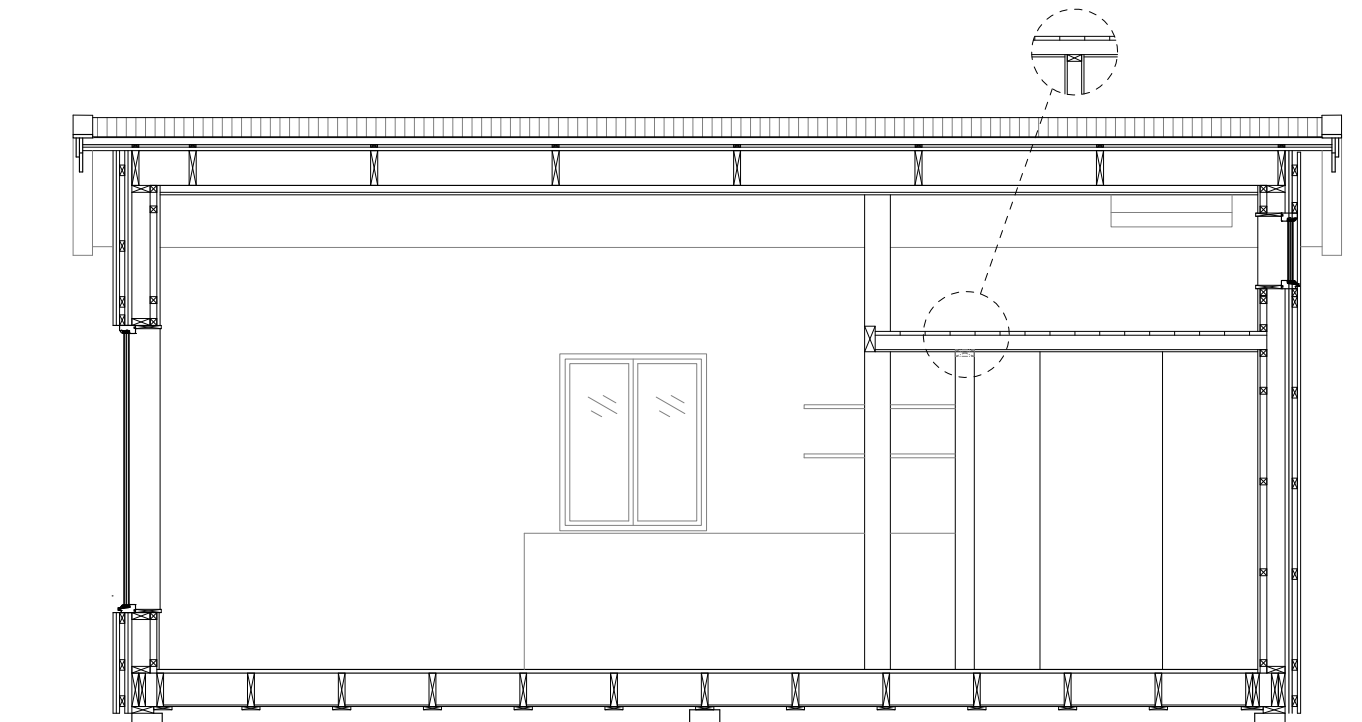
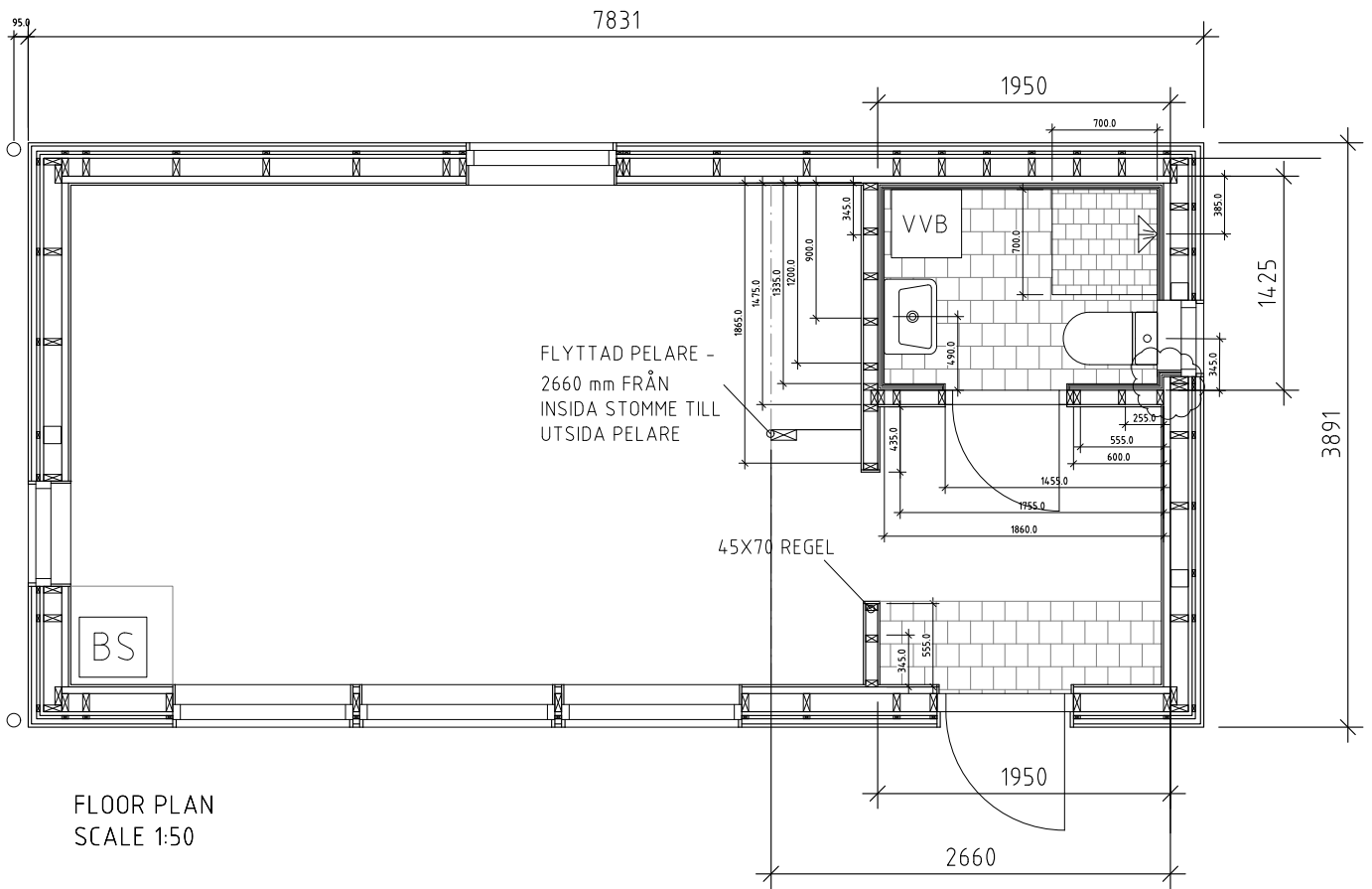

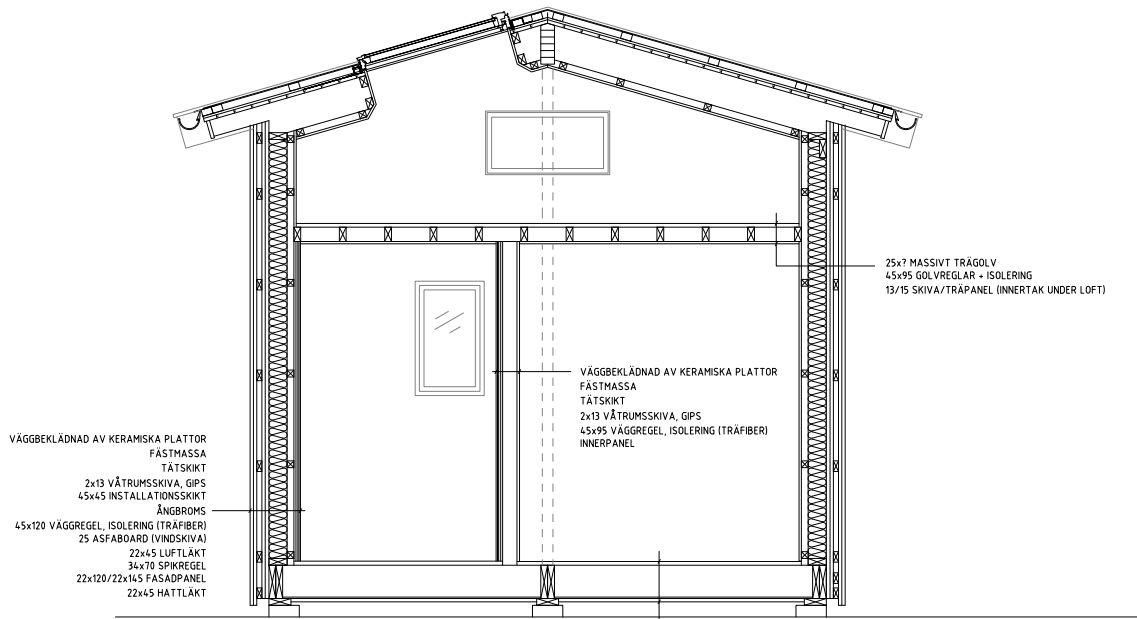

SECTION A-A
SCALE 1:50

25x7 MASSIVT TRÄGOLV/ALT SKIVA - PARKETT GOLV
45x220 GOLVREGLAR + ISOLERING
9 TROSSBOTTENSKIVA
22 BLINDBOTTENBRÄDA

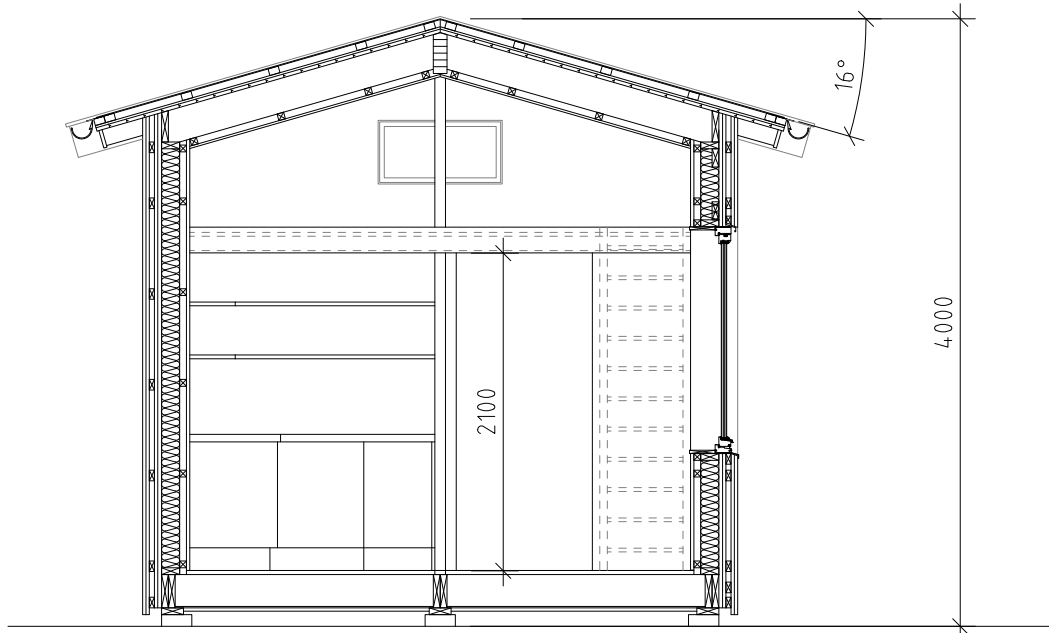

SECTION B-B
SCALE 1:50

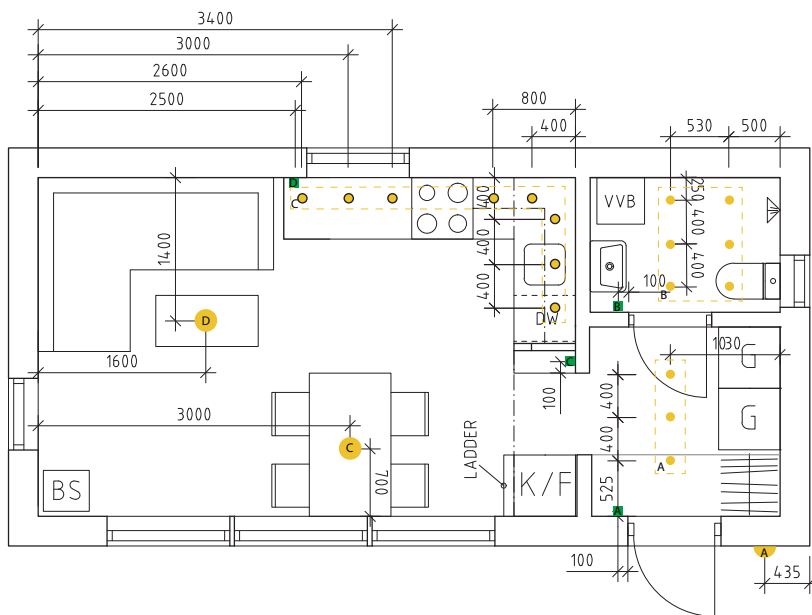

*Installationsritning - Plan 1
Lampor och strömbrytare*

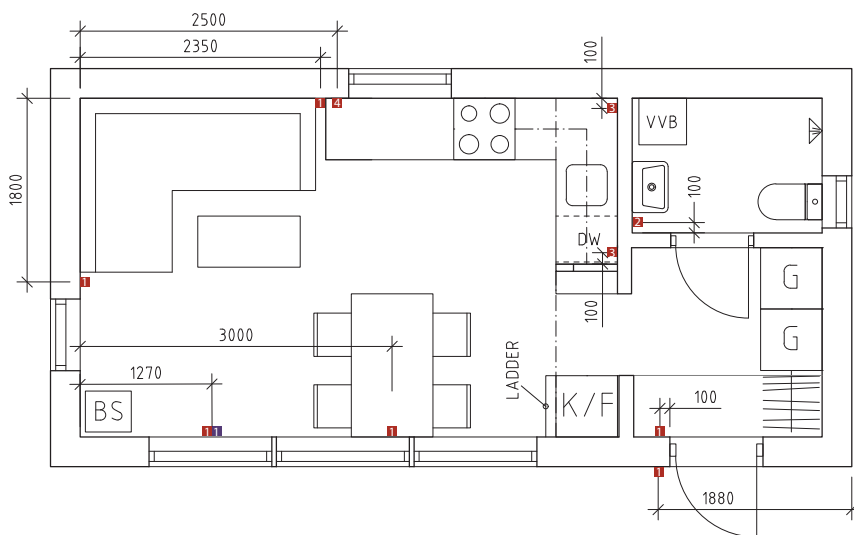

*Installationsritning - Plan 1
Eluttag och Telekomuttag*

APPENDIX II

Presentation

THE REHOUSE PROJECT

- Filling the gap between reuse as concept and as reality



TABLE OF CONTENT

Introduction

Background
Research questions
Method

Part 1 - Reuse as concept

Part 2 - Reuse in reality

Filling the gap

Answering research questions
Reflection



Introduction

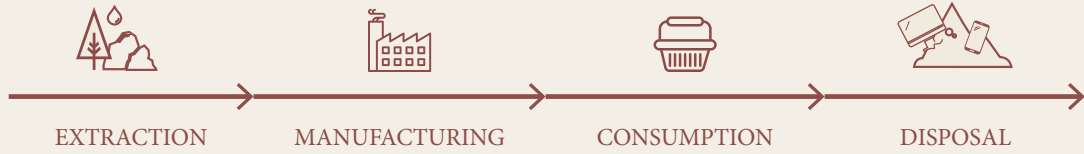
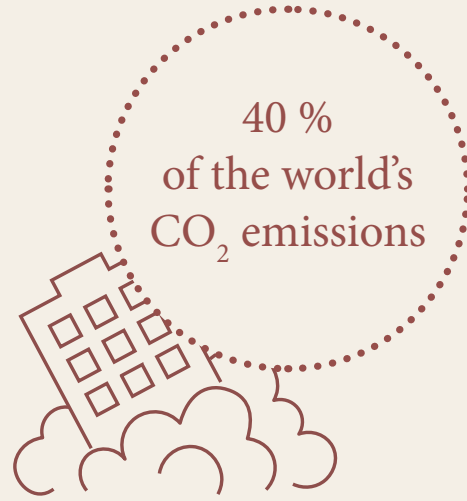
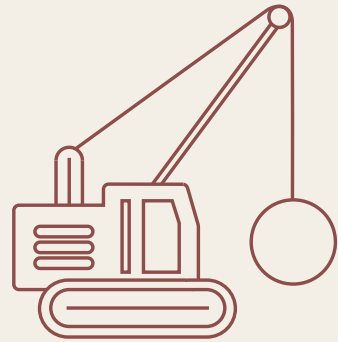

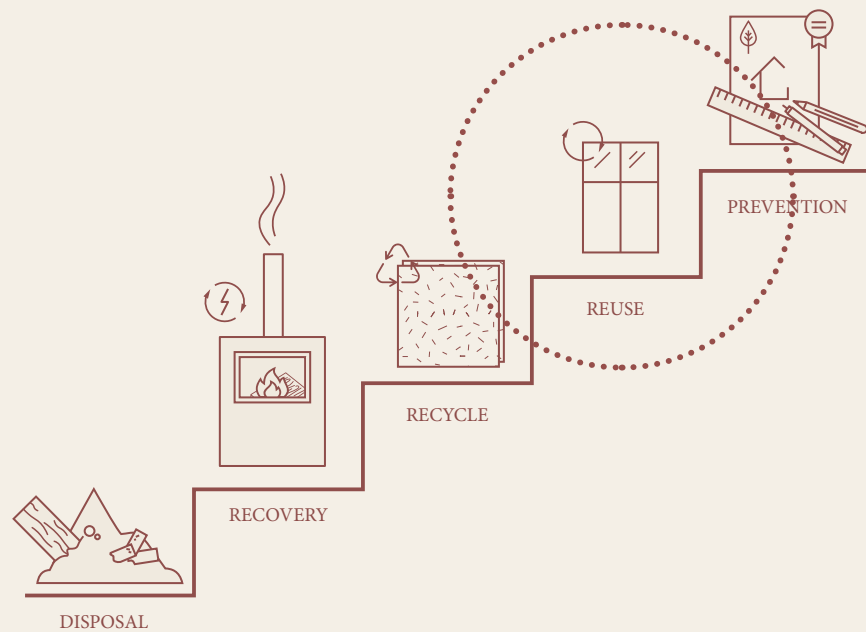
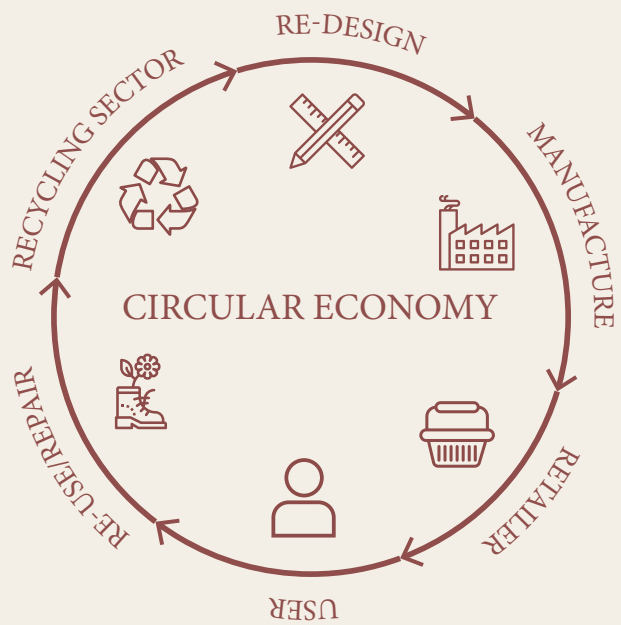

In what way can architects contribute to an increase of reuse projects in Sweden?

What effects do working with reused materials have on the architectural design process?

Method

Arkitektens återbruksmetodik

En rapport från White Research
White arkitekter AB, oktober 2017

form
follows
availability



A
changemaker's
guide to
the future



Reuse as concept

- Research for design
- Literature studies
- Interviews



Reuse in reality

- Research by design
- Practical experience
- Designing & building



Part 1

Reuse as concept

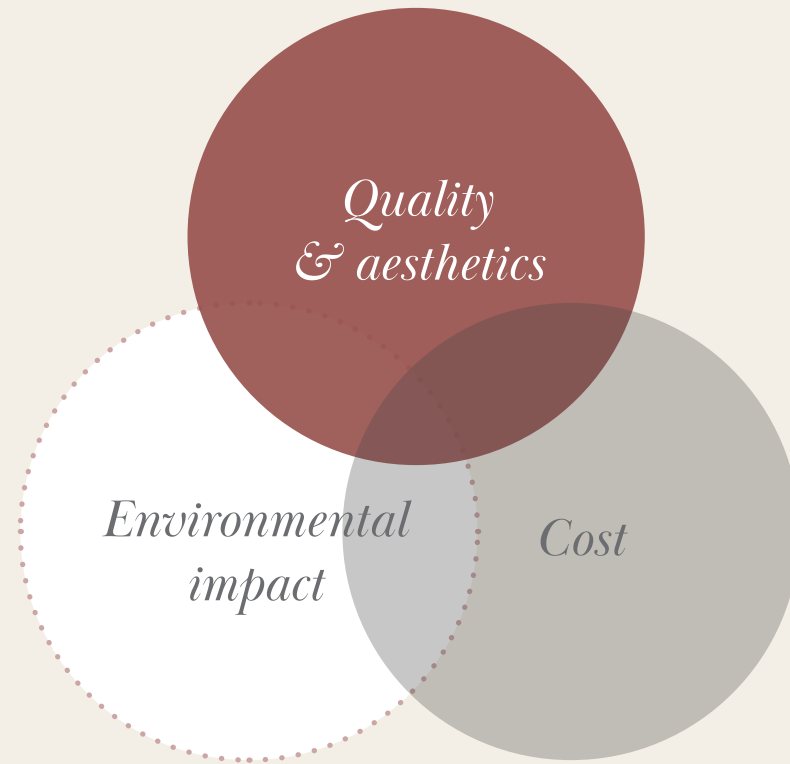

The relation between cost and values

- Wood
- Straw
- Cellulose

*Low embodied energy
or low quality*

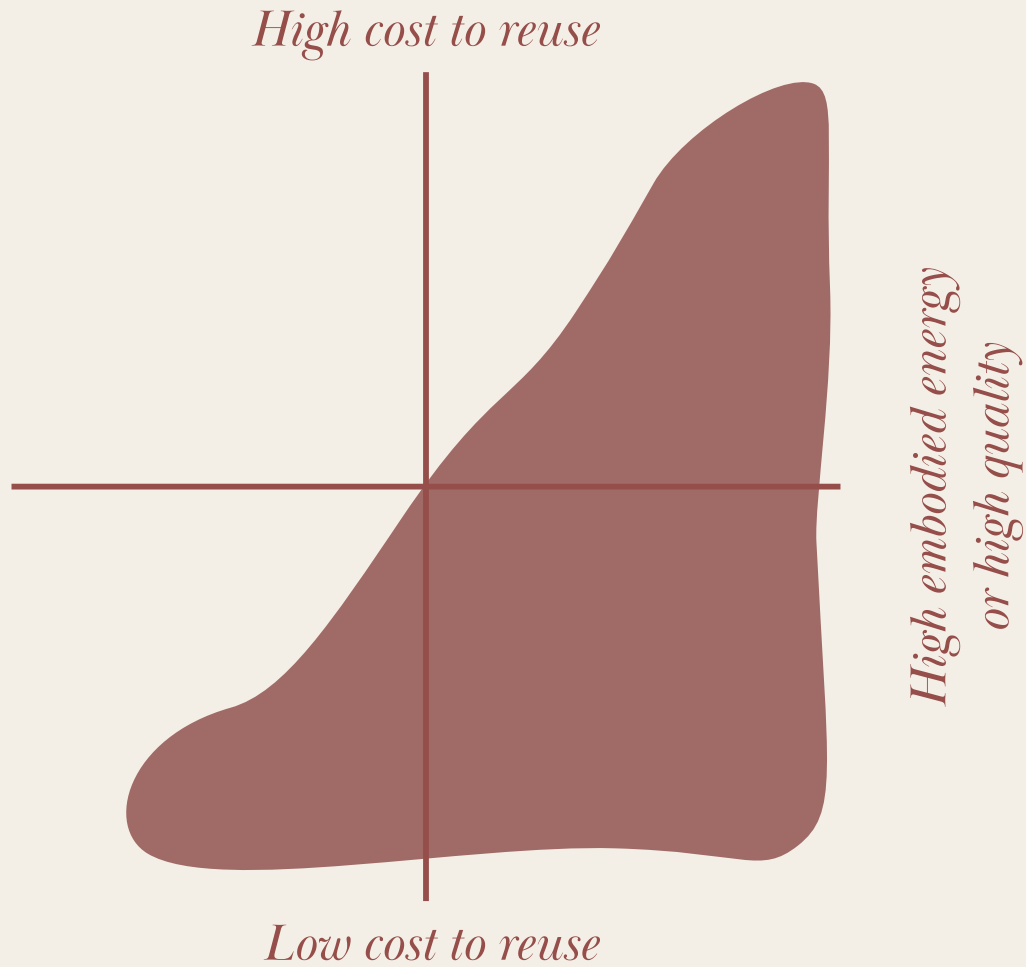

- Window glass
- Concrete
- Metal
- Drywalls
- Bricks



Townhouses in Svartlamon by Nøysom arkitekter (Photo by Nøysom arkitekter)



Upcycle studios by Lendager Group (Author's private)

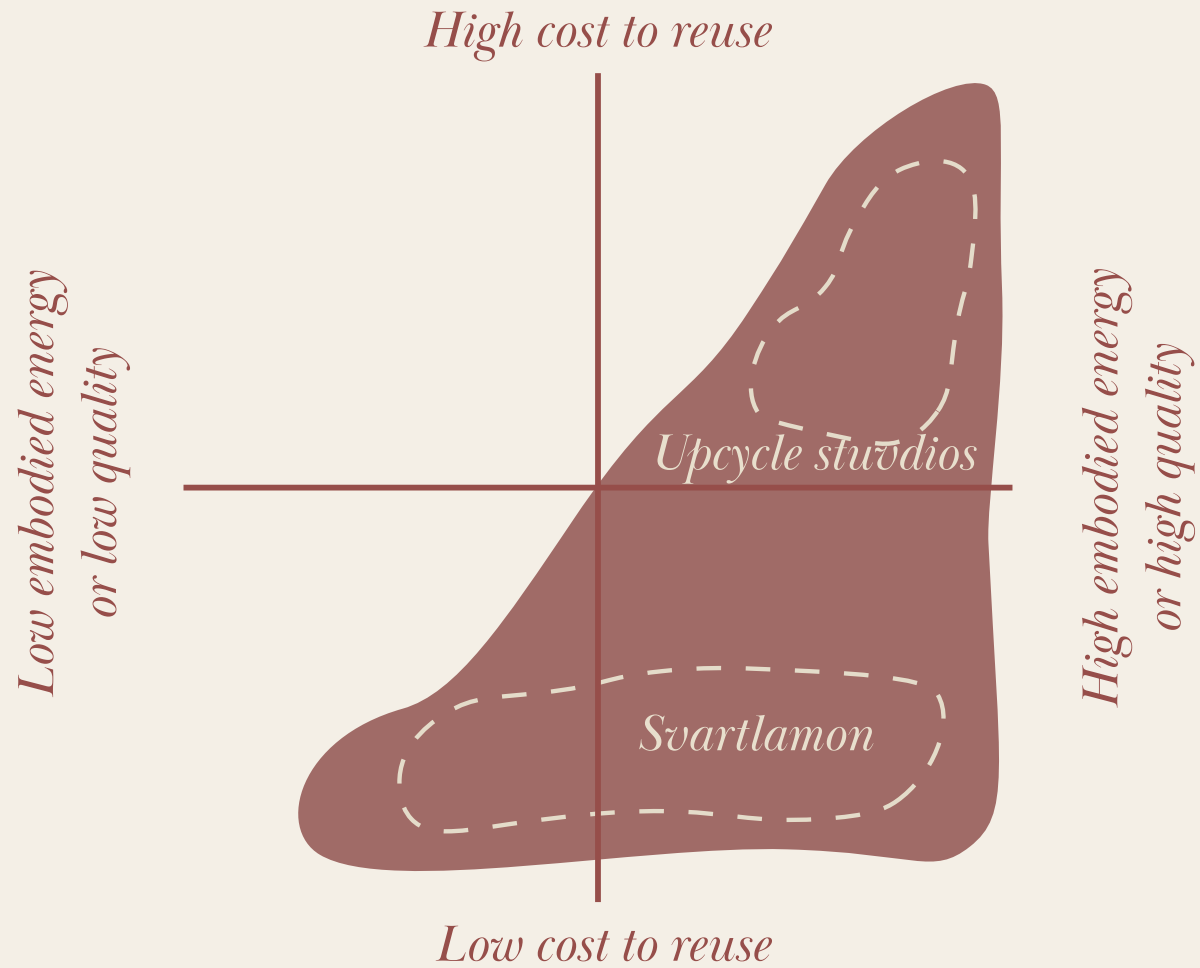

The relation between cost and values

The reuse design process

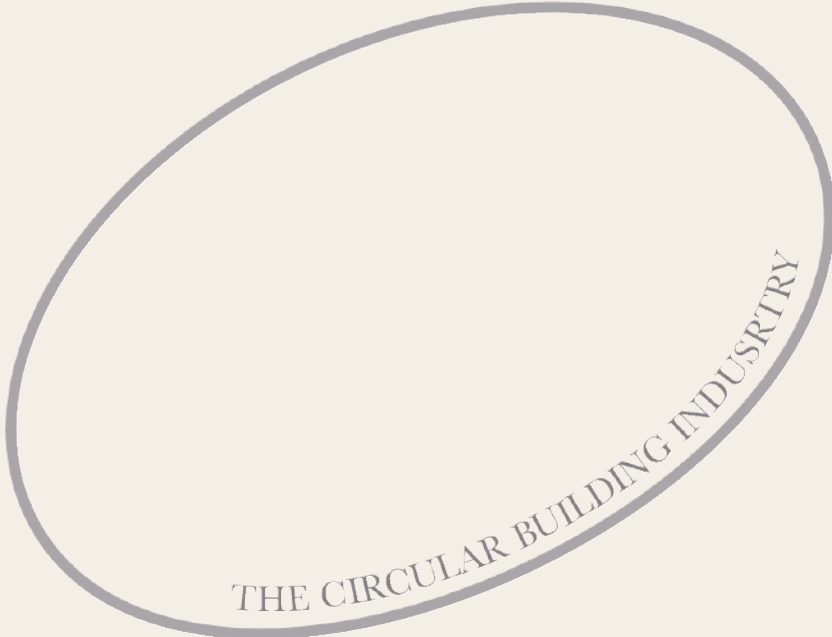



The reuse design process



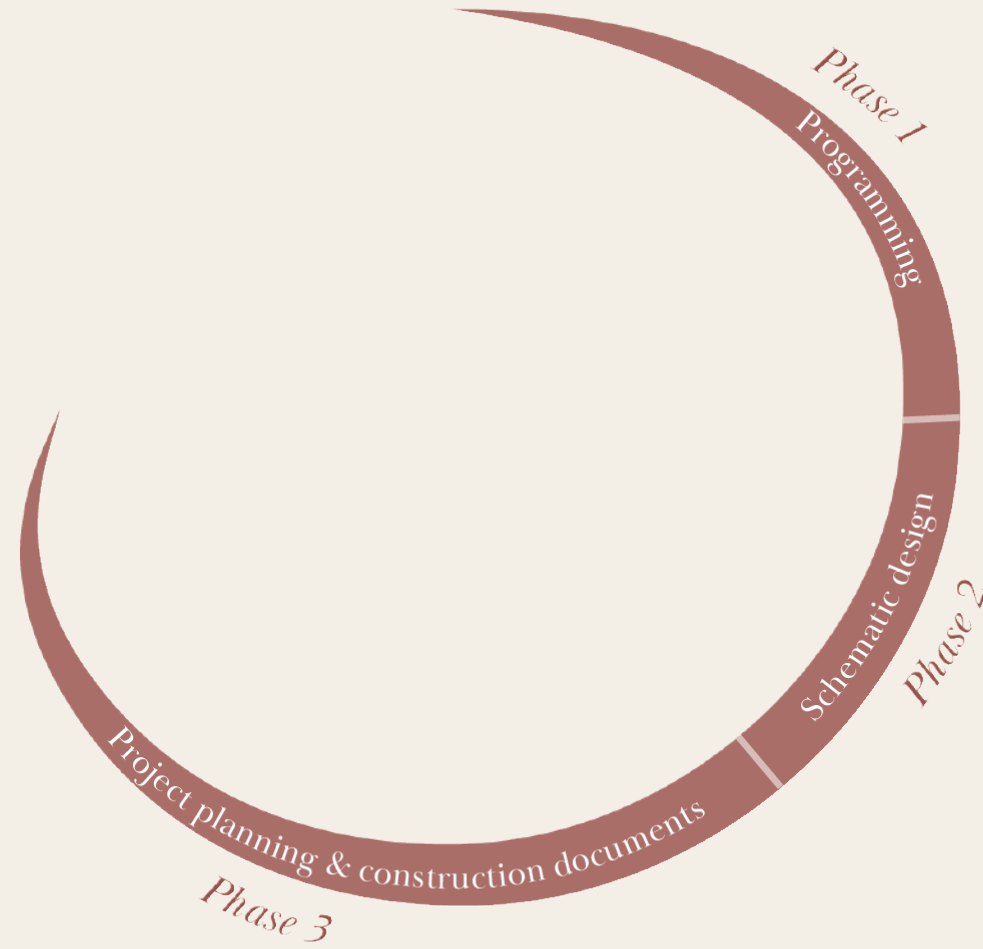

The reuse design process

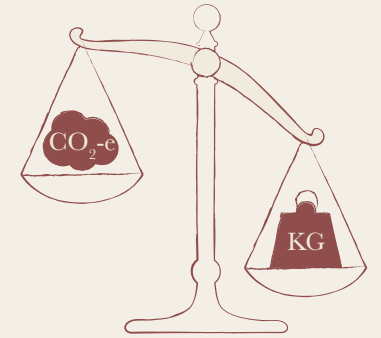
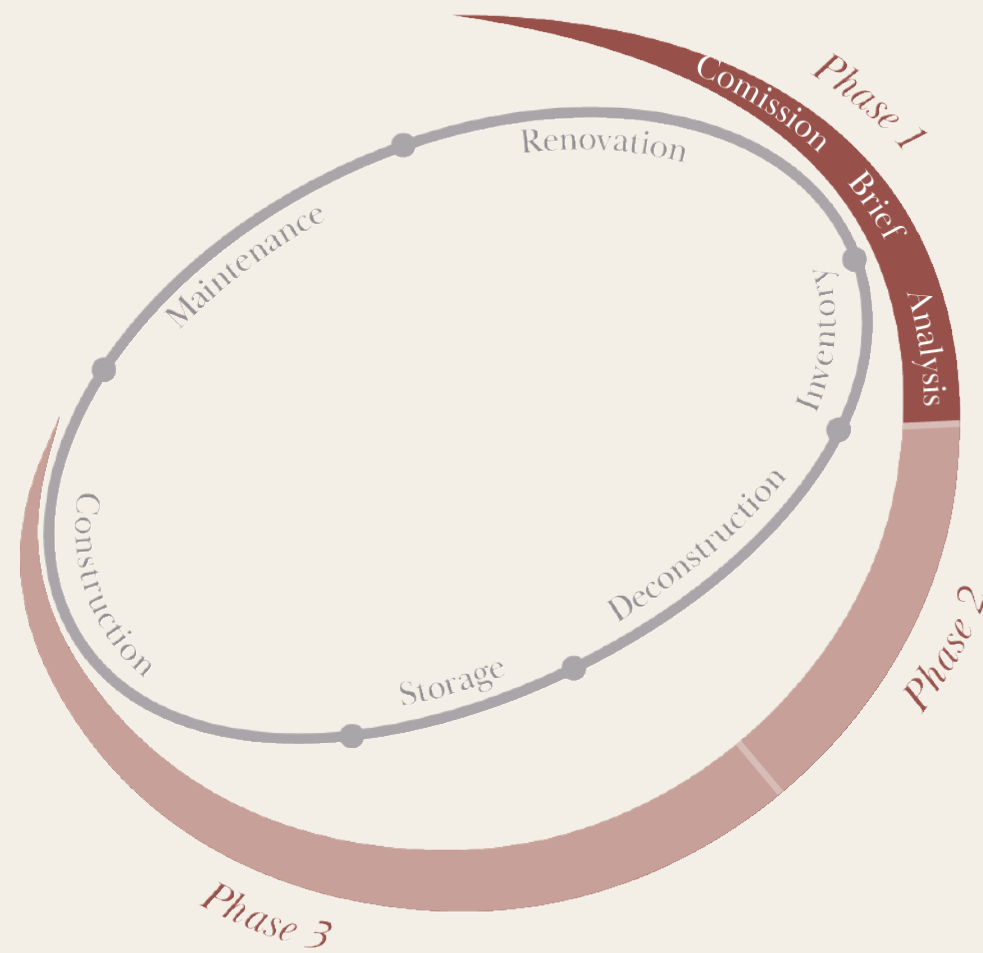

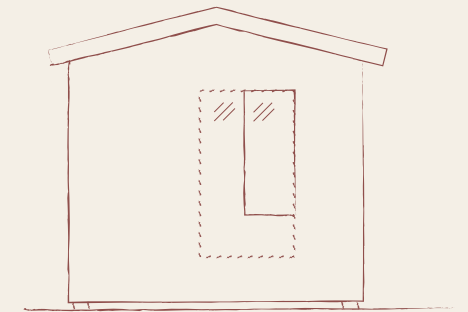
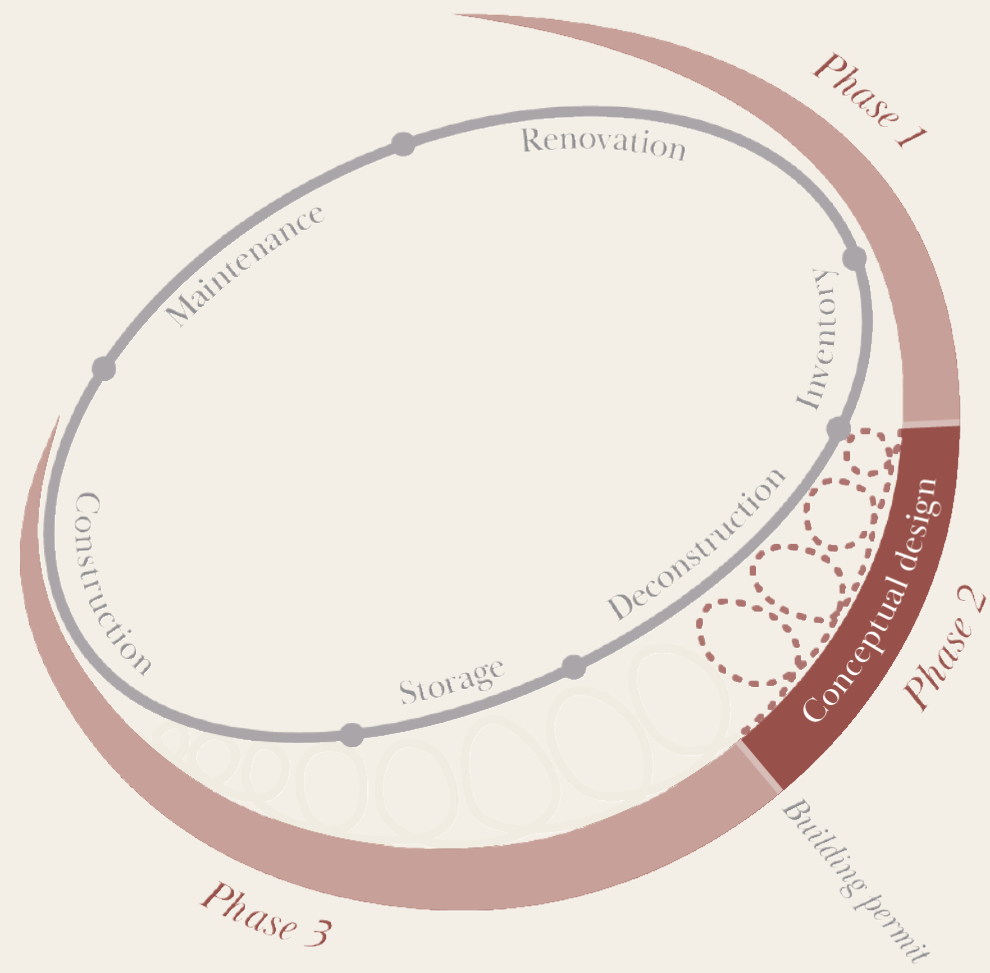

The reuse design process

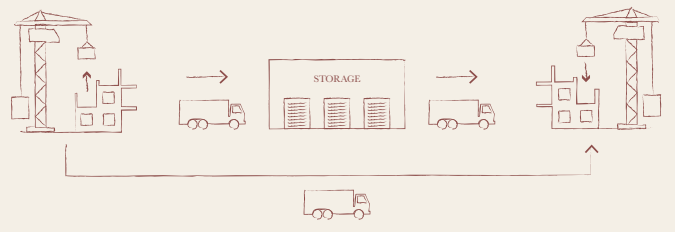
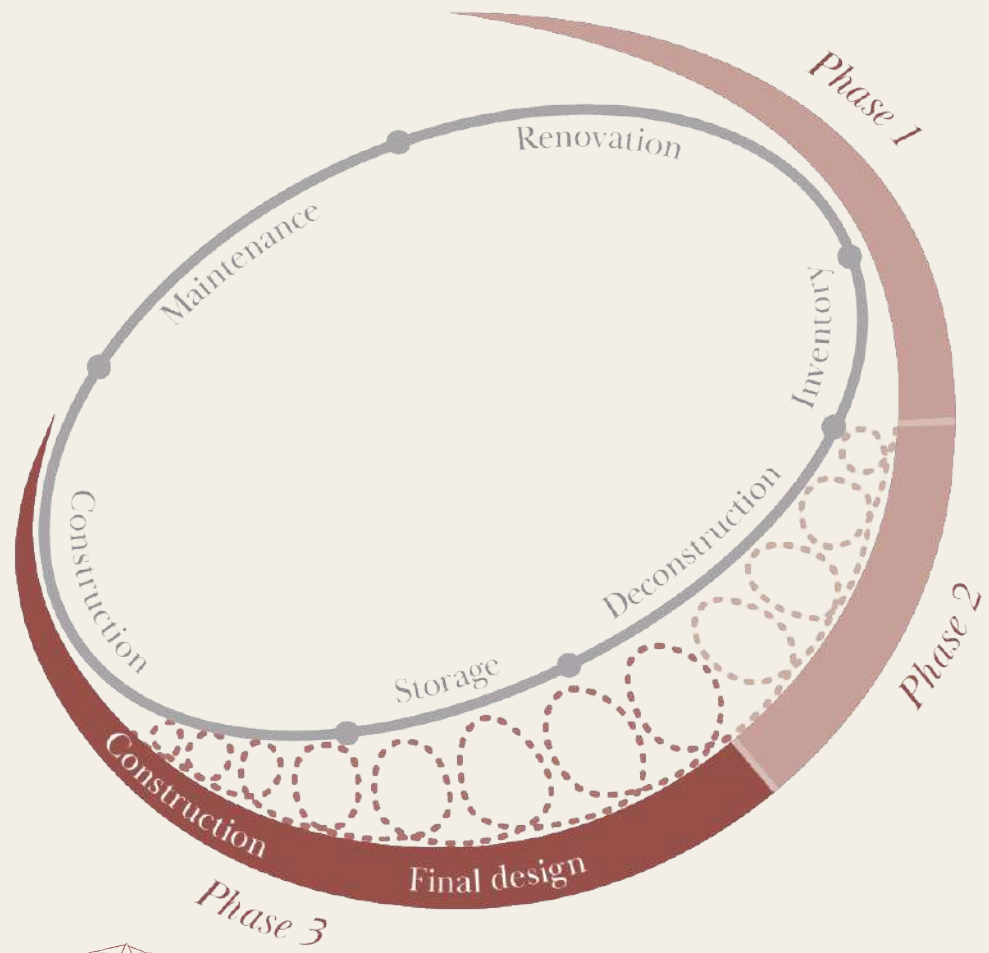

The reuse design process

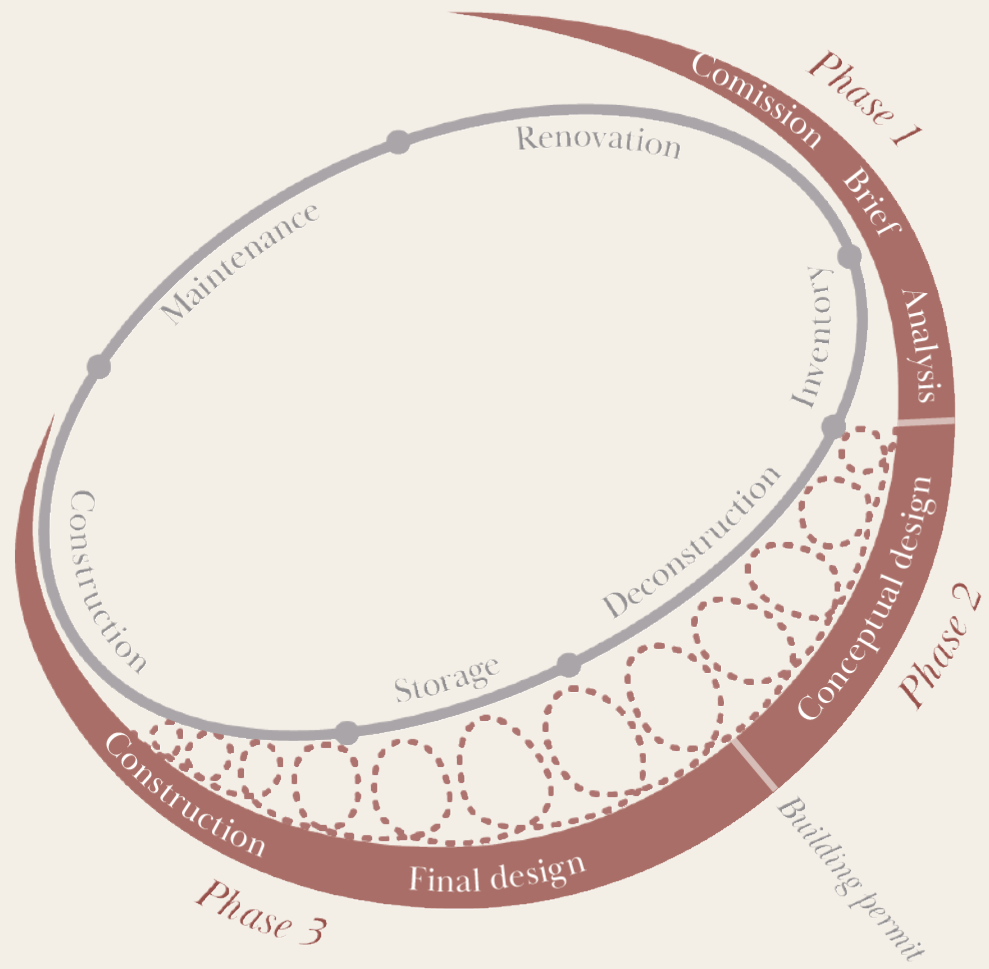

The reuse design process

Part 2

Reuse in reality

Project introduction



Eco materials

- Eco-friendly materials
- Low embodied

Reuse

- 100% reused materials
- As much material as possible
- Long-term quality
- Assumed embodied energy

Future reuse

- Movable house
- Material reuse & recycling
- No module design

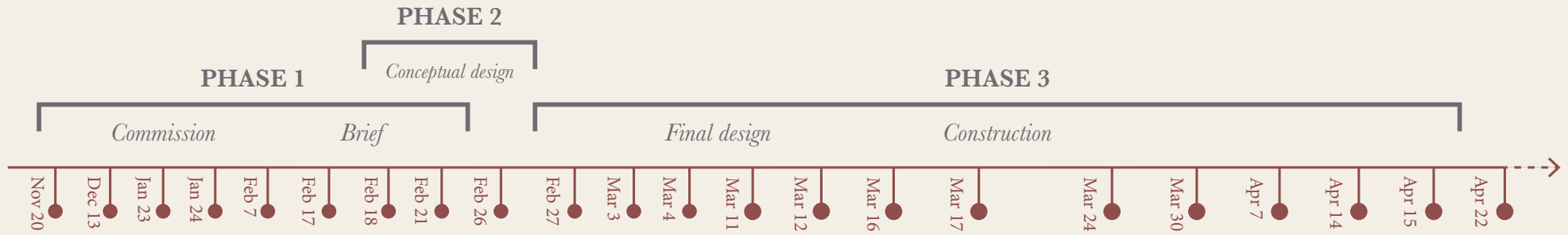
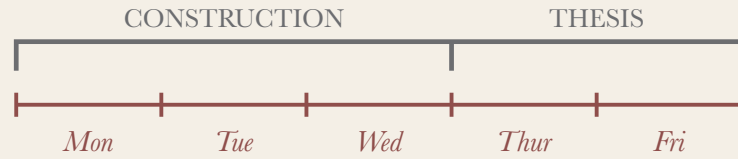

Timeline

Phase 1 - Collaboration



EGNAHEMSFABRIKEN,
TJÖRN

CHALMERS UNIVERSITY
OF TECHNOLOGY, GÖTHEBURG

VAROBACKA



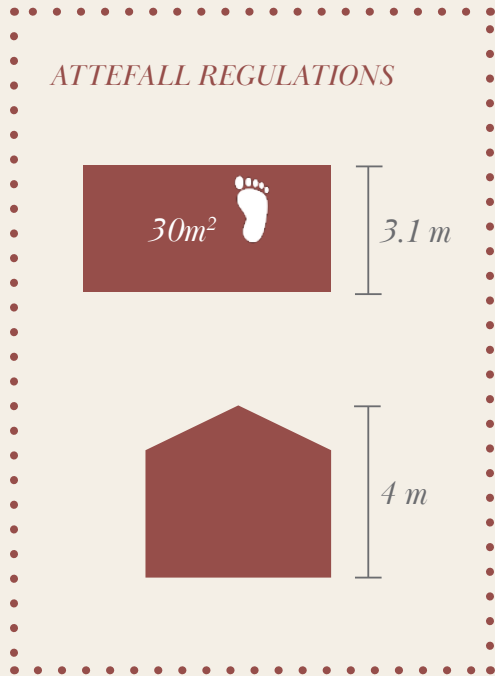

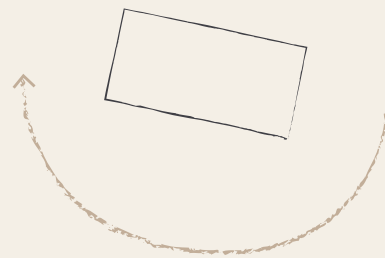

Sun path

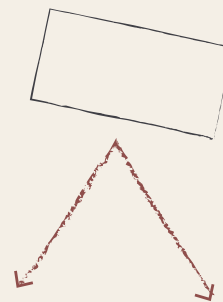

Seaview

Phase 2 - Design



Material inventory

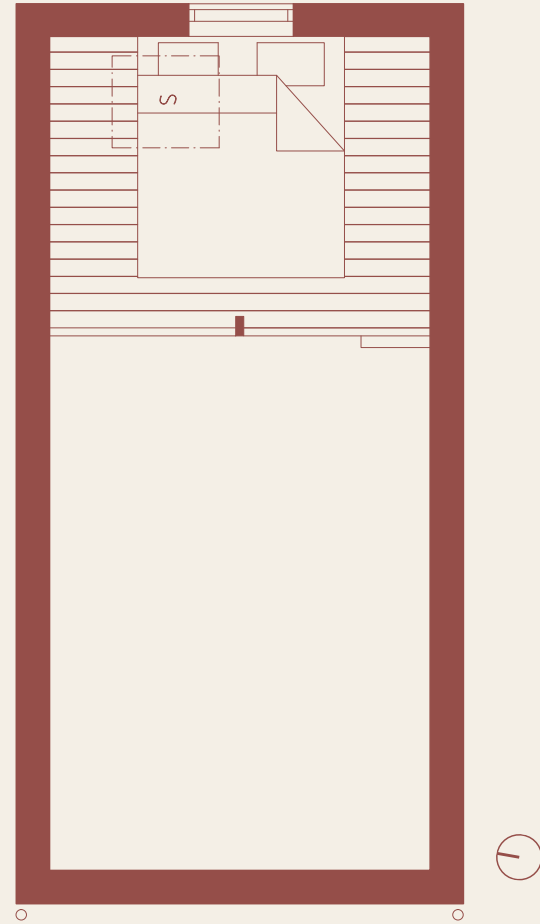
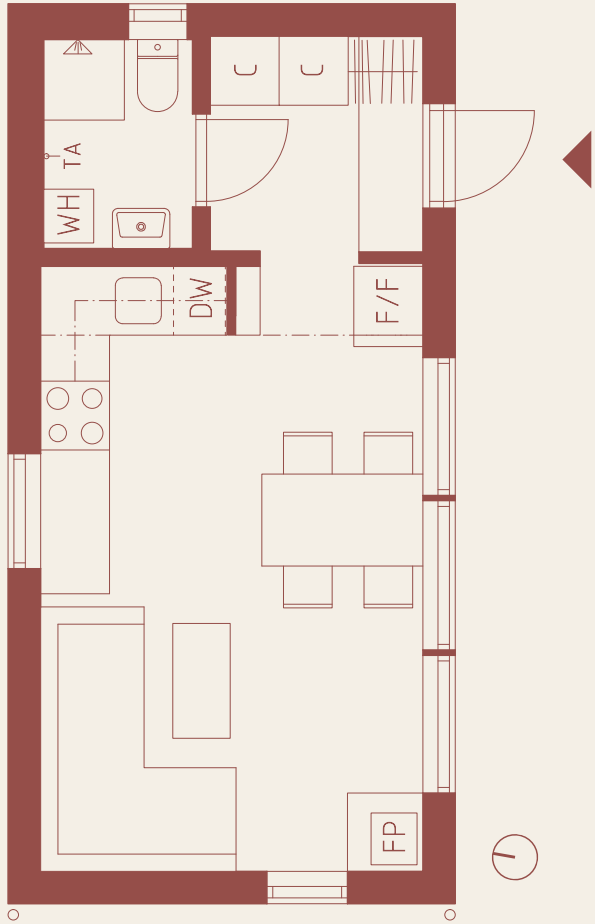



Kitchen

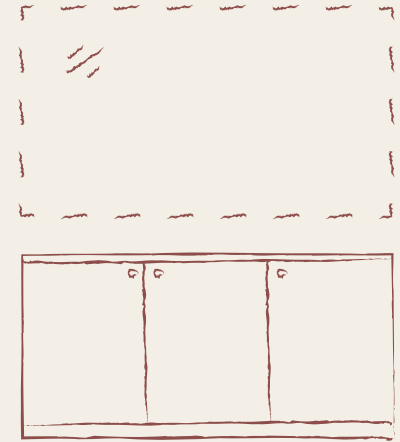
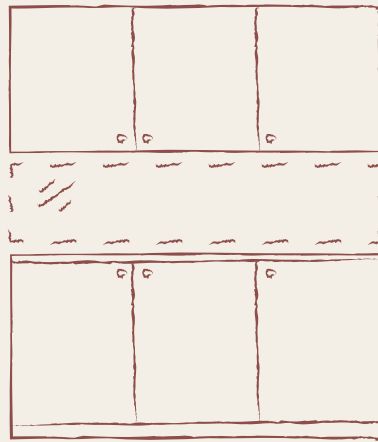

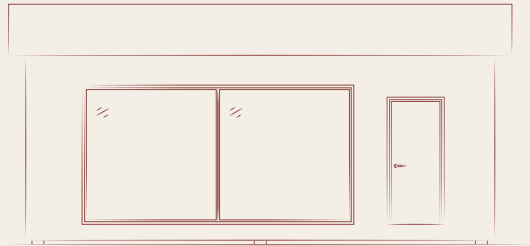

1.

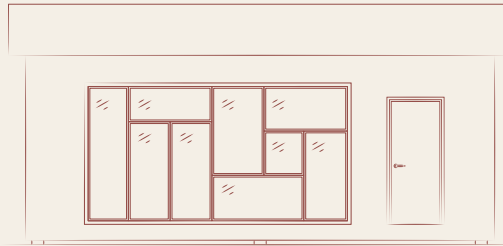

2.

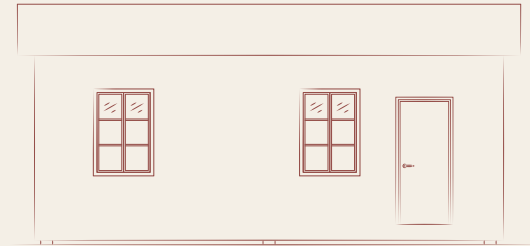

3.



4.

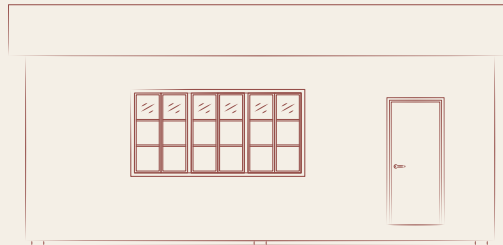

5.



6.

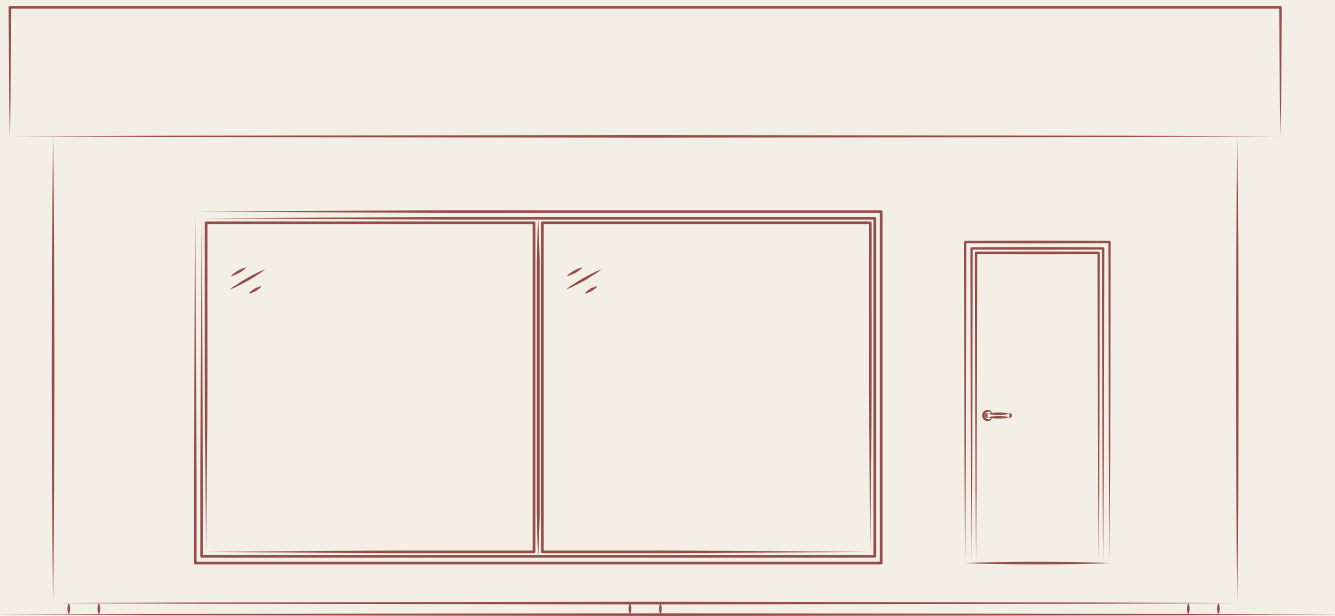

Southern windows

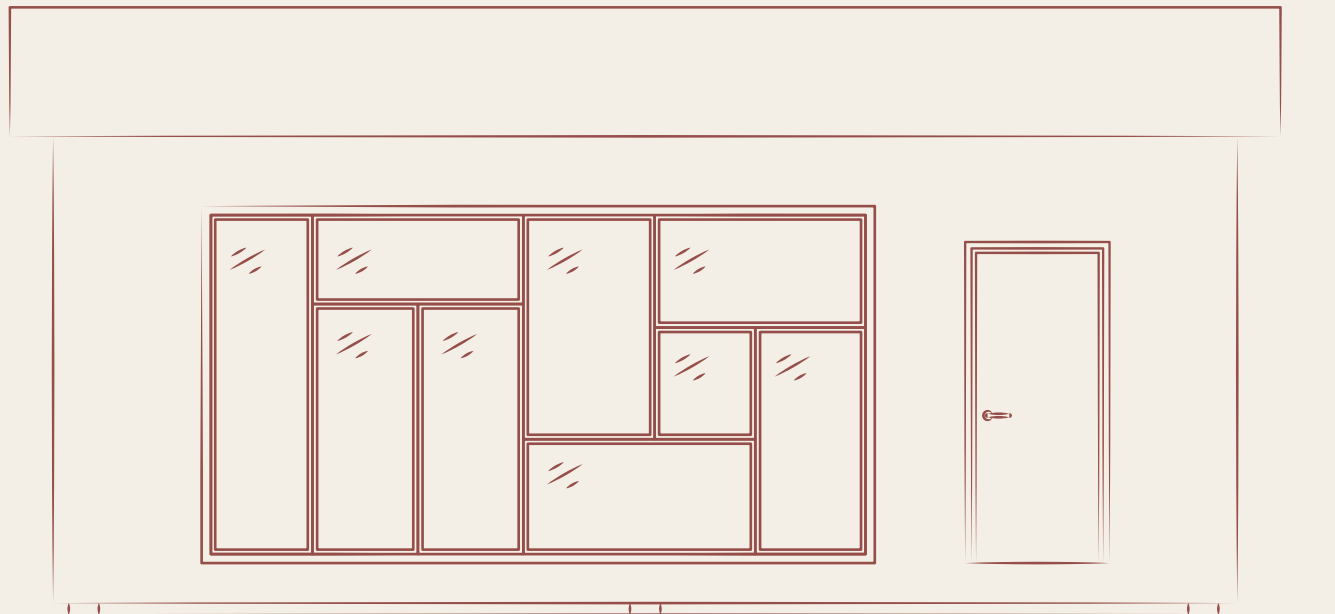

Southern windows



Homemade frames



Southern windows

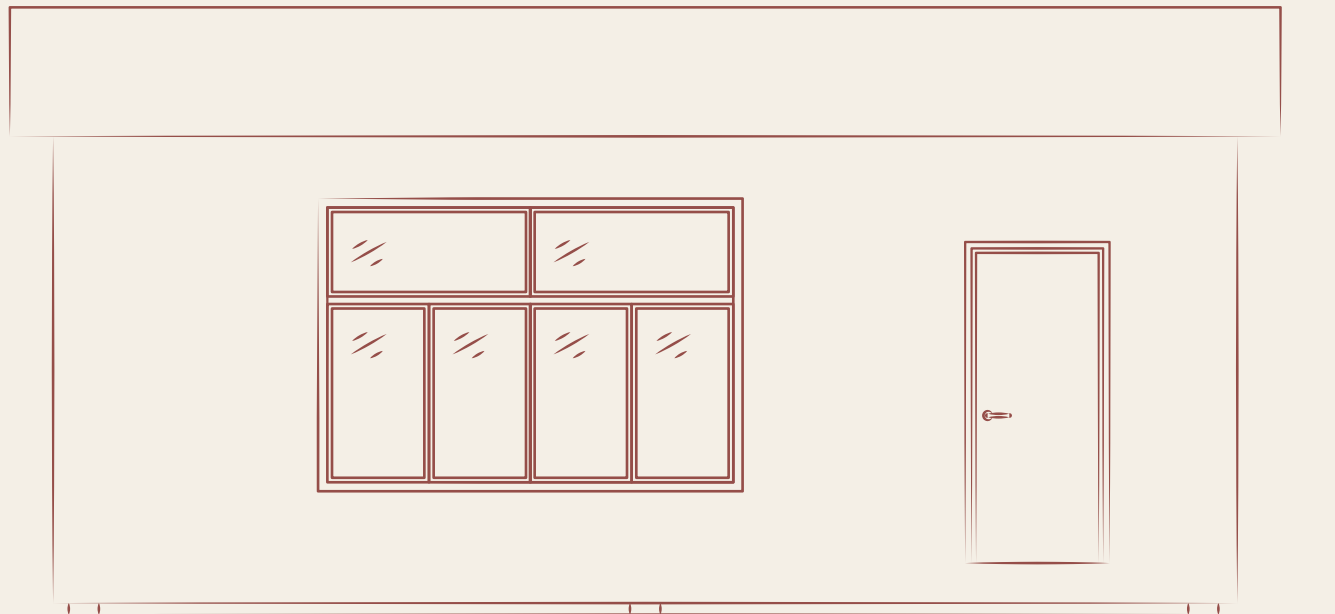

Southern windows

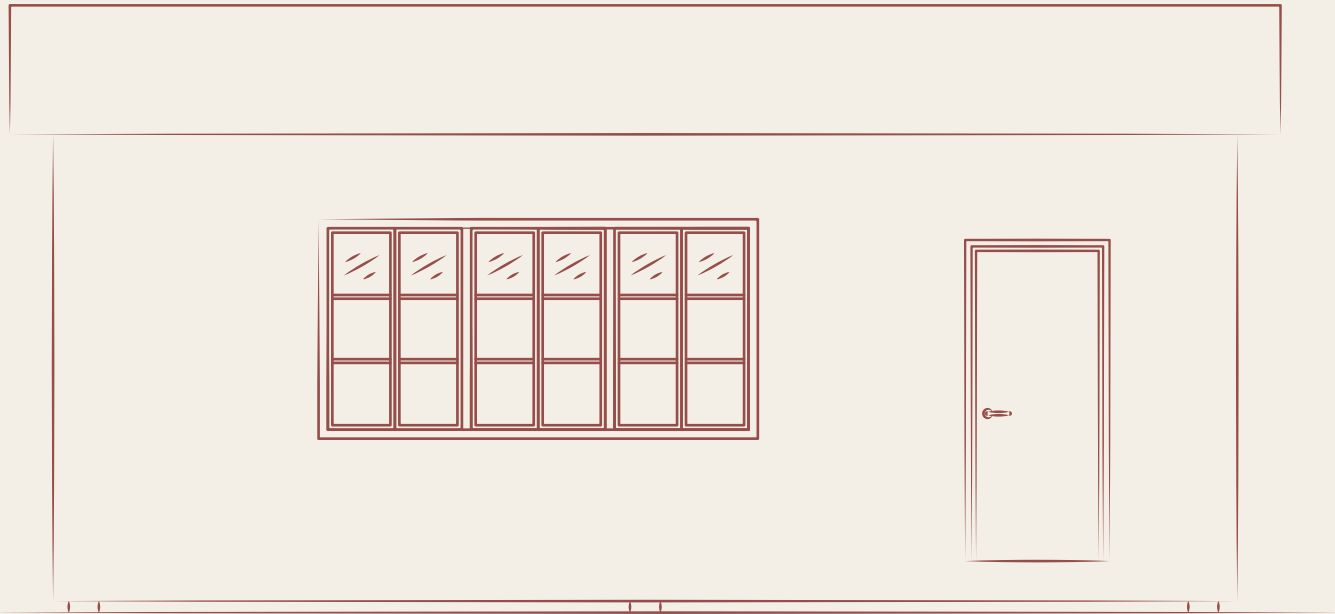

Southern windows



Southern windows

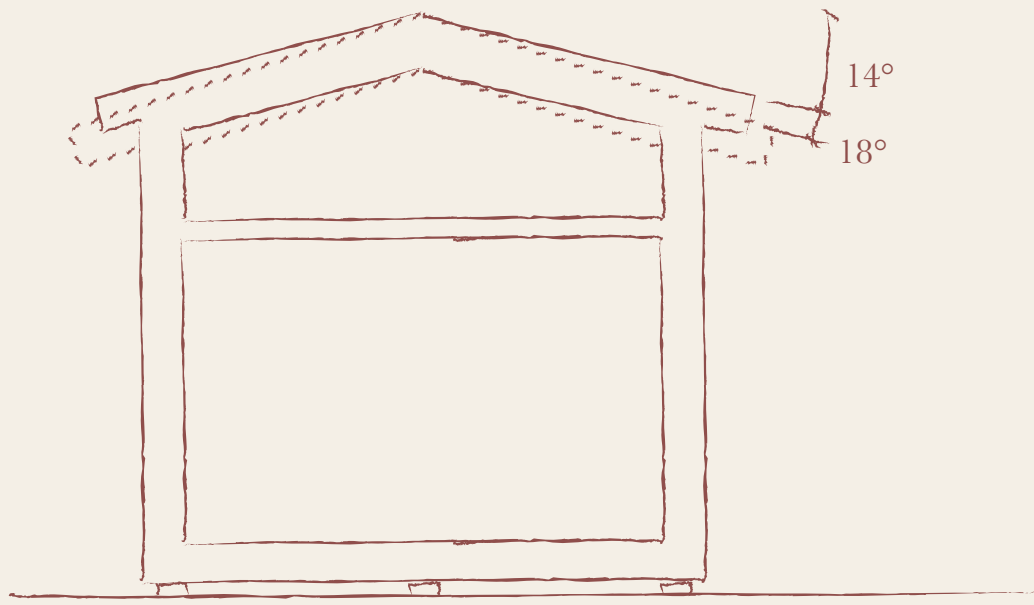

Roof

Phase 3 - Construction

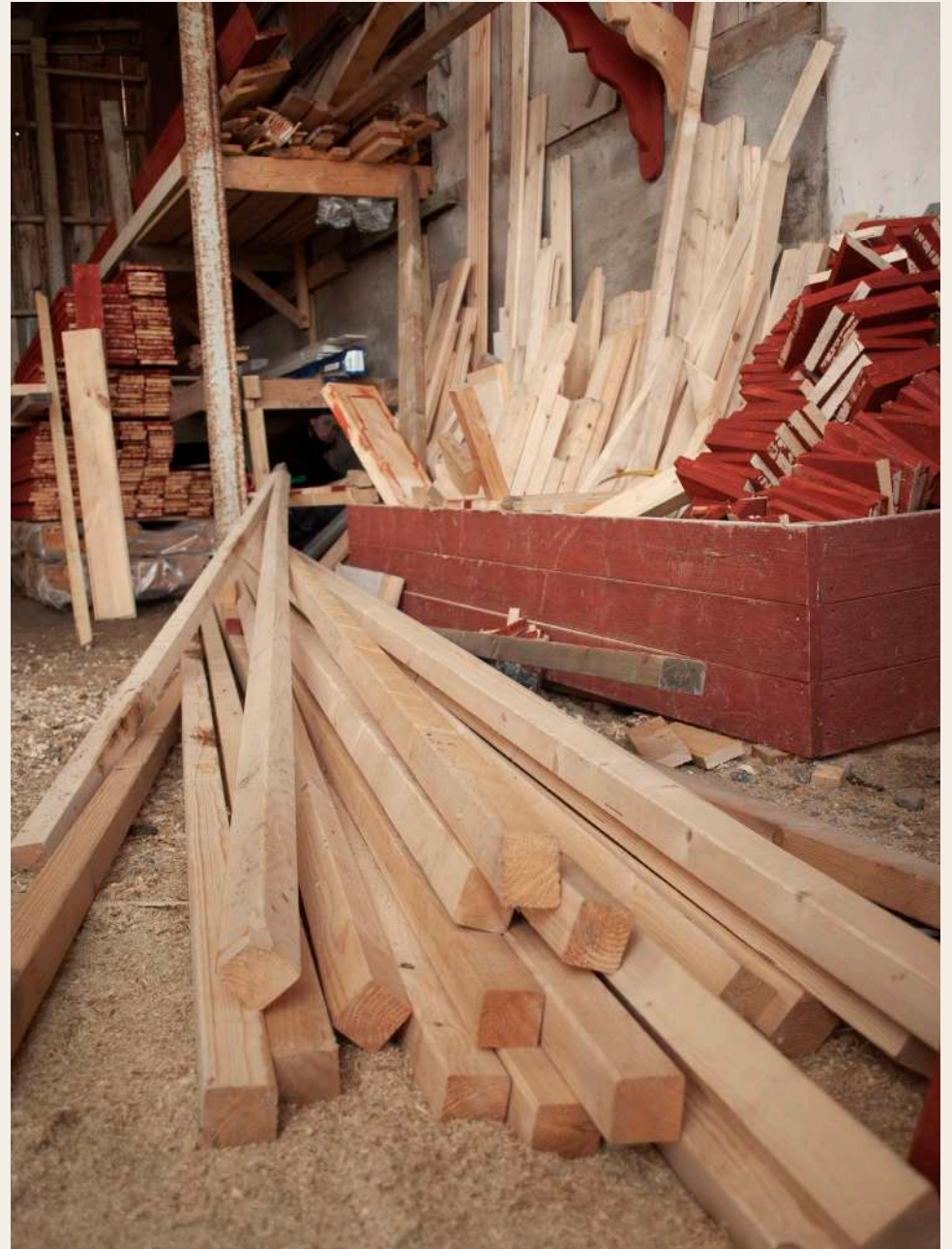



- Mold
- Moisture
- Bad smell
- Worse insulation values
- Different systems













DEROME CE 15 001-CPR-2015-1 EN 15497:2014 F-SKARV K-VIRKE-GRAN C24H PUR-EN15425 I 70 FJ 0-1 S 191208

DEROME
7 82 91 - 42

DEROME
7 82 91 - 42

C24H DEROME CE 0402 DRY GRADED 07 W006 GE

DEROME
7 82 91 - 42

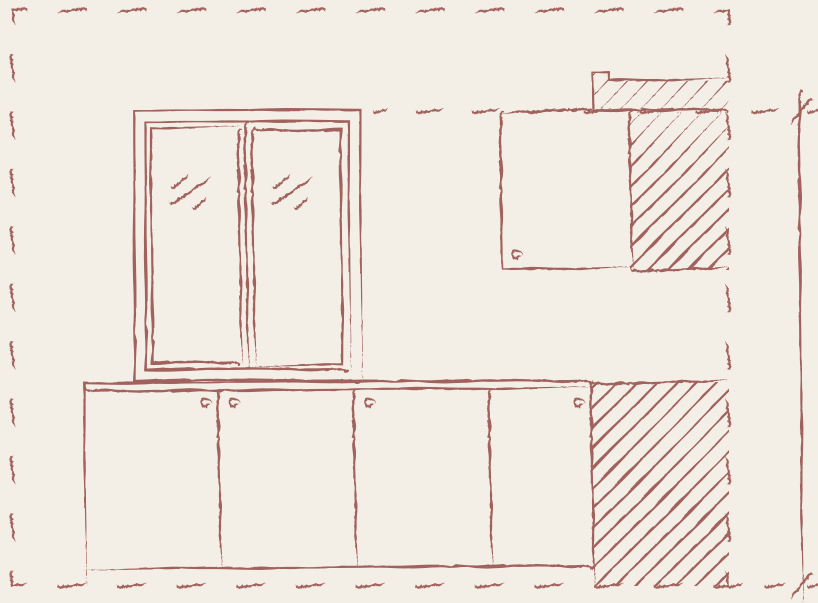

2100

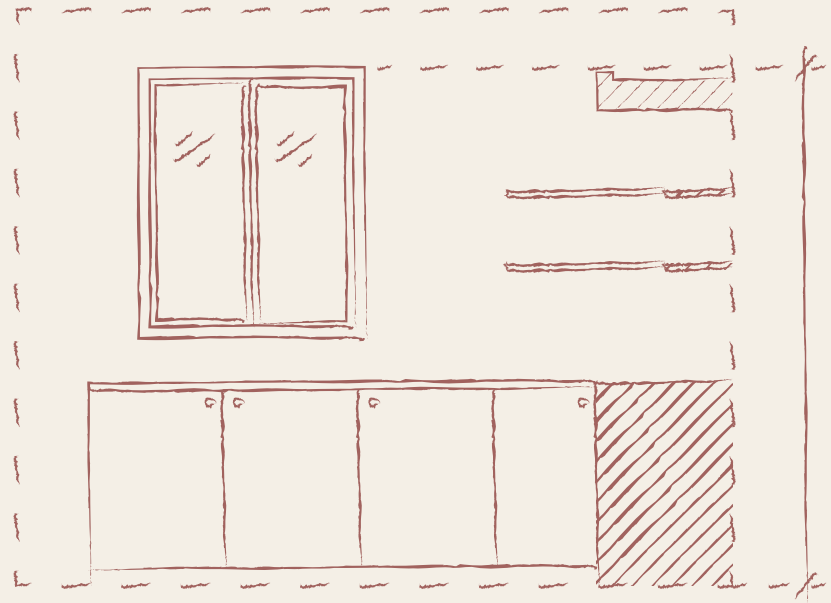

2300







Reused windows



















Carpenters taking over

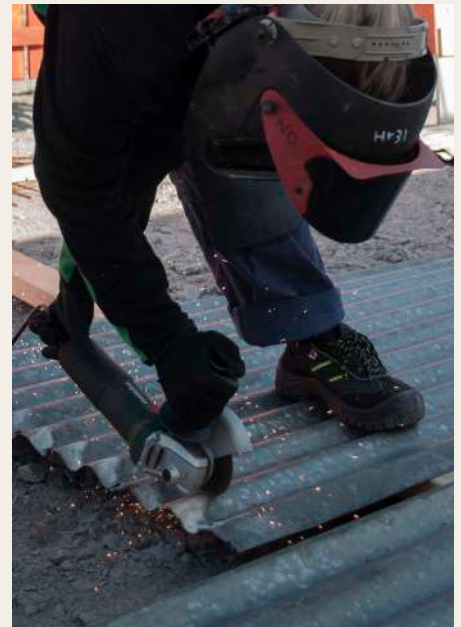

Reused metal sheet roof



Gutter brackets and holes



Mounting of asfboard



Facade color - Falu Red

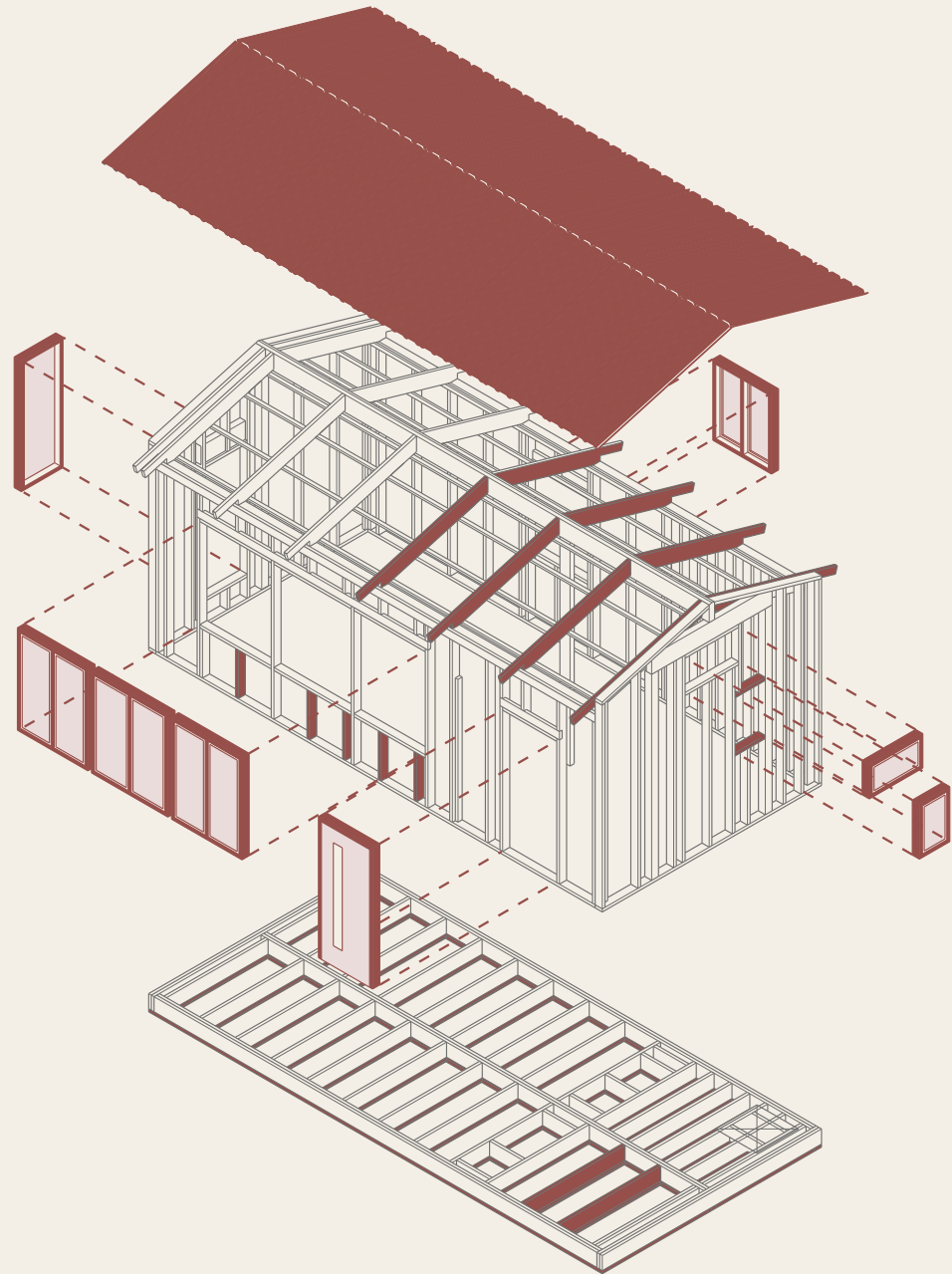

Project process

*Access on
second hand
market*



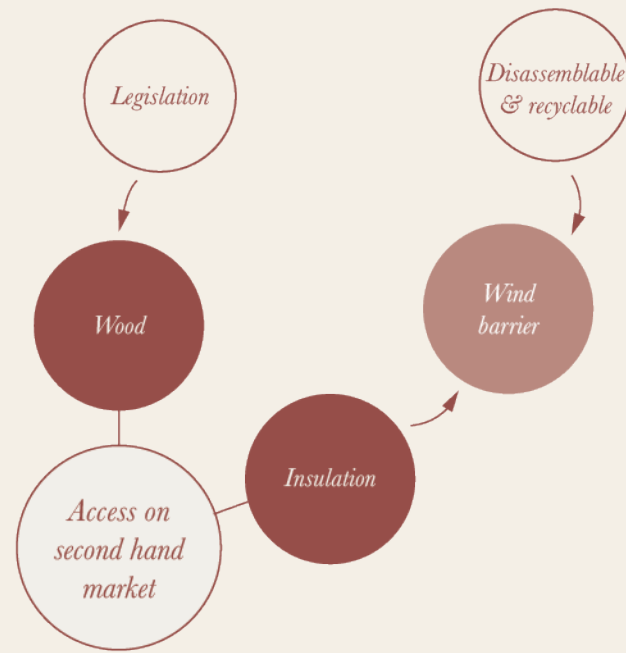



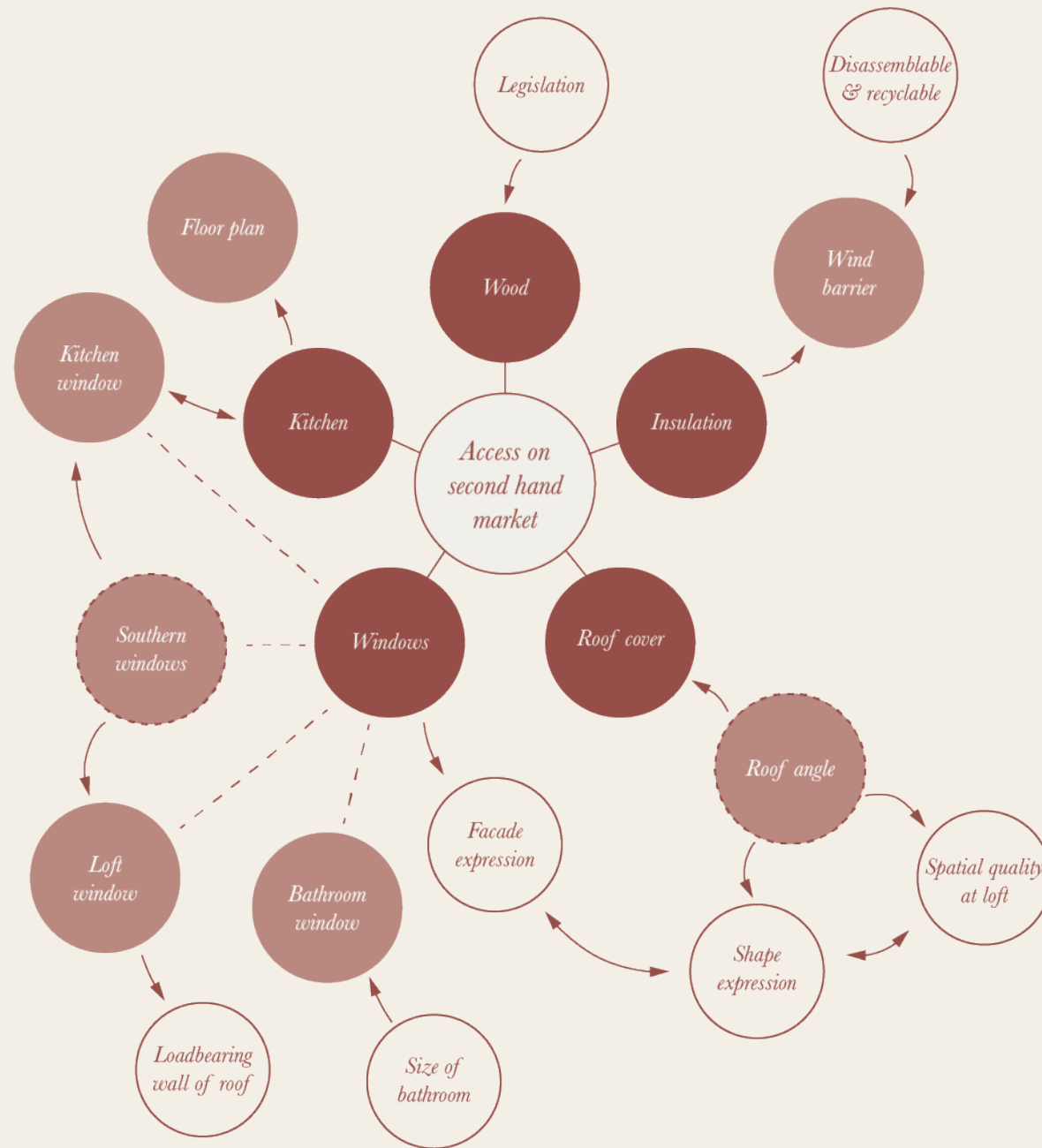

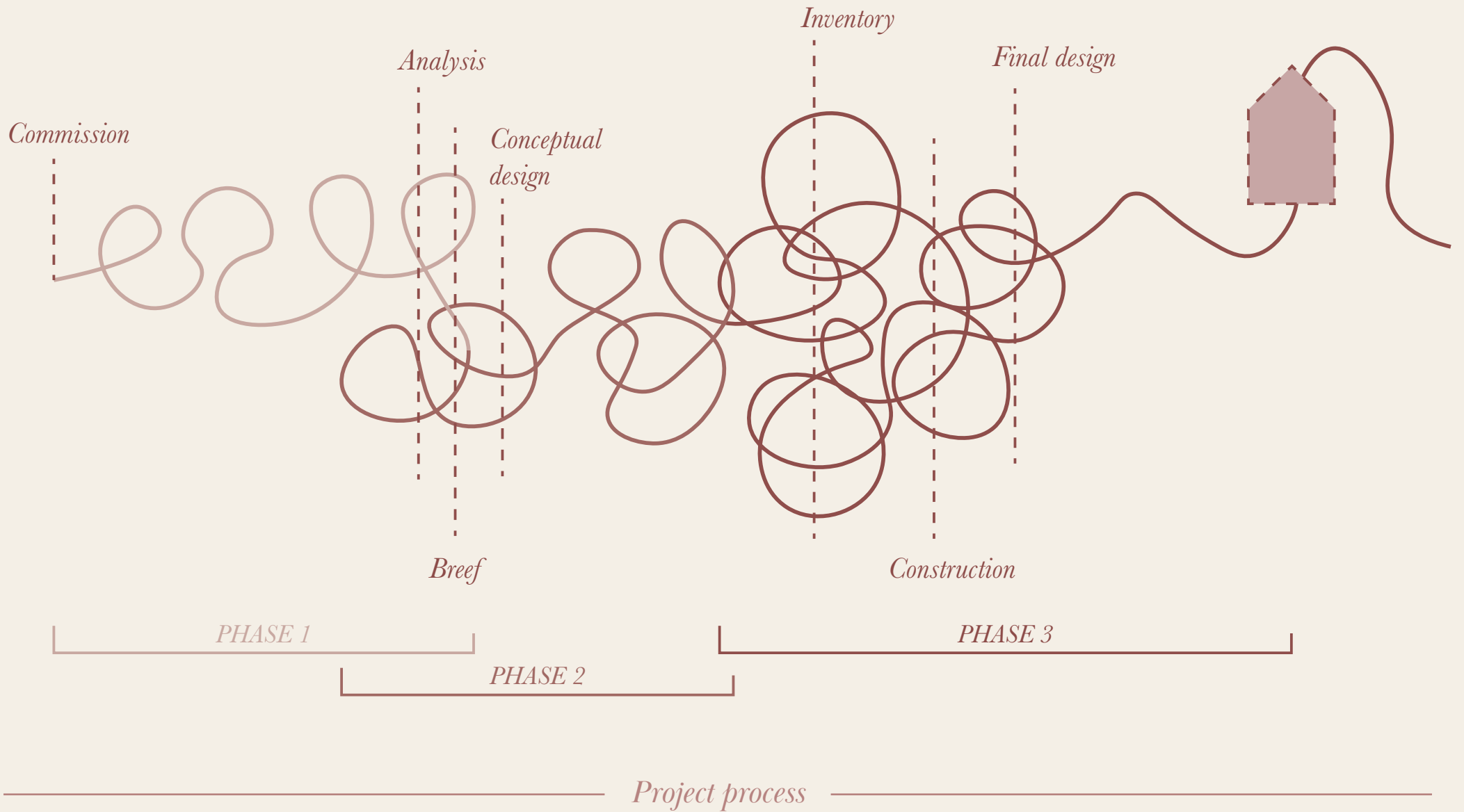

Filling the gap

1.

In what way can architects contribute to an increase of reuse projects in Sweden?

In what way can architects contribute to an increase of reuse projects in Sweden?



Research question 1

In what way can architects contribute to an increase of reuse projects in Sweden?



In what way can architects contribute to an increase of reuse projects in Sweden?

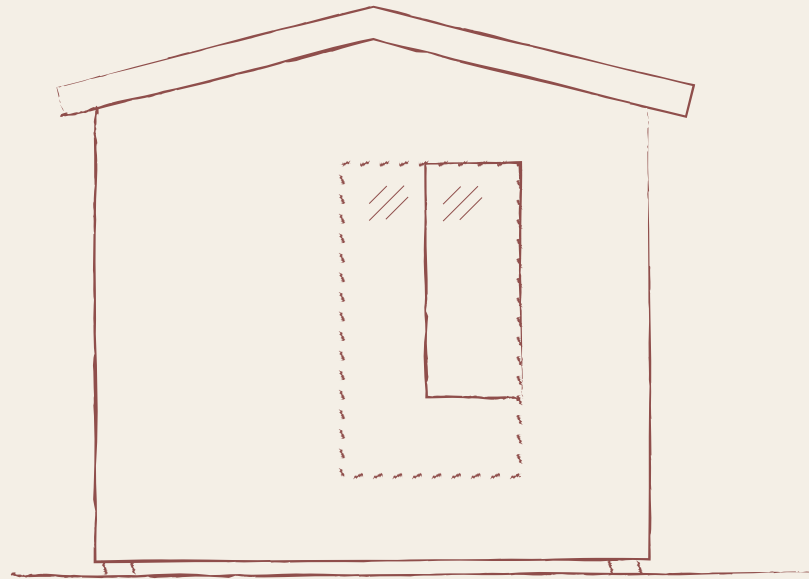

In what way can architects contribute to an increase of reuse projects in Sweden?

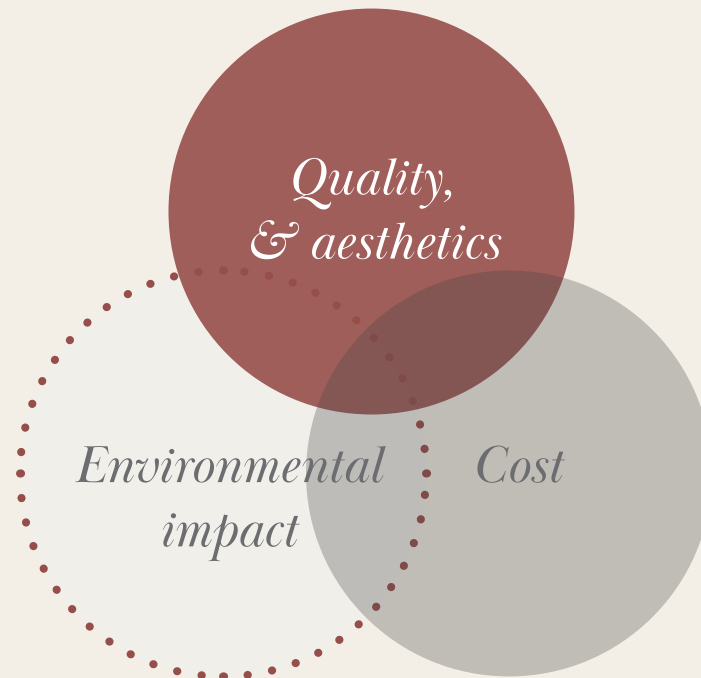

In what way can architects contribute to an increase of reuse projects in Sweden?

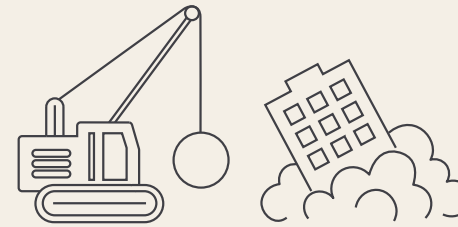
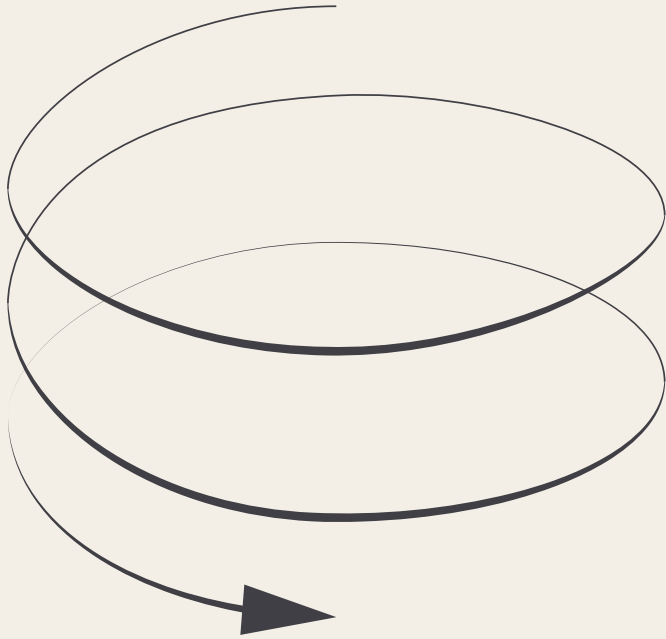

In what way can architects contribute to an increase of reuse projects in Sweden?

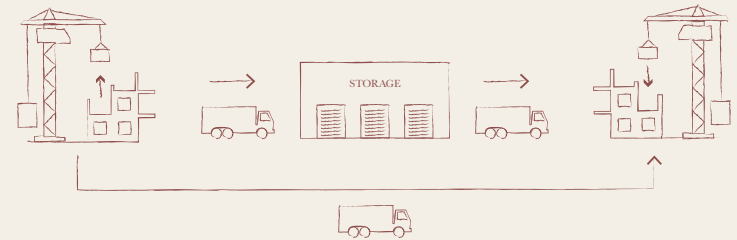
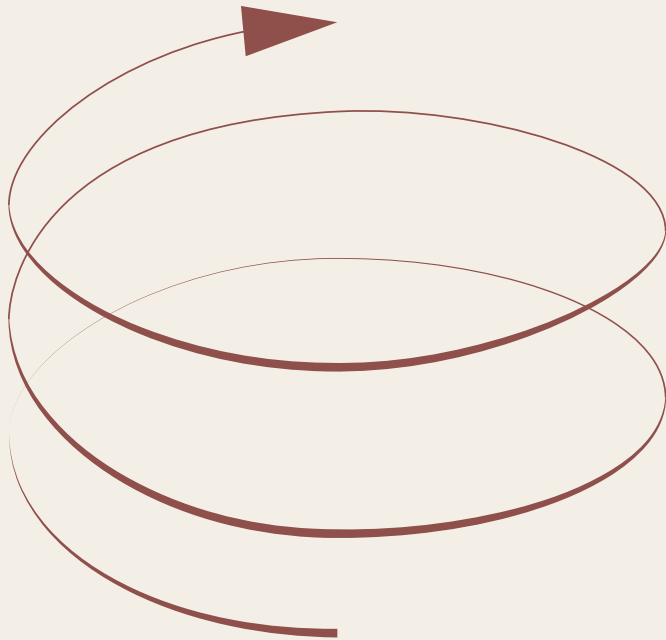

2.

What effects do working with reused materials have on the architectural design process?

What effects do working with reused materials have on the architectural design process?



What effects do working with reused materials have on the architectural design process?



What effects do working with reused materials have on the architectural design process?

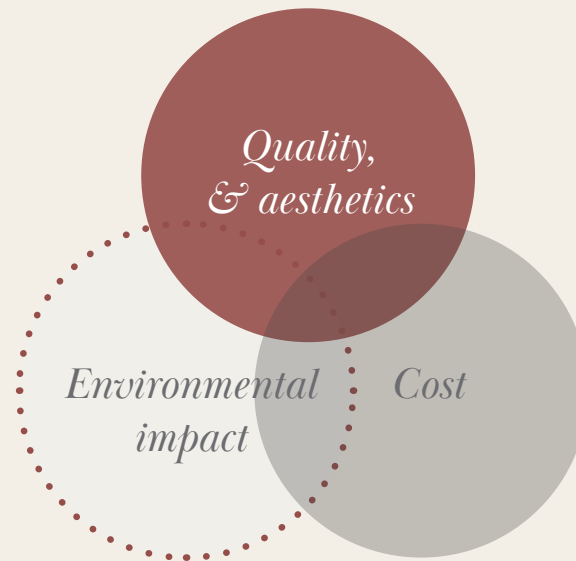

Reflection

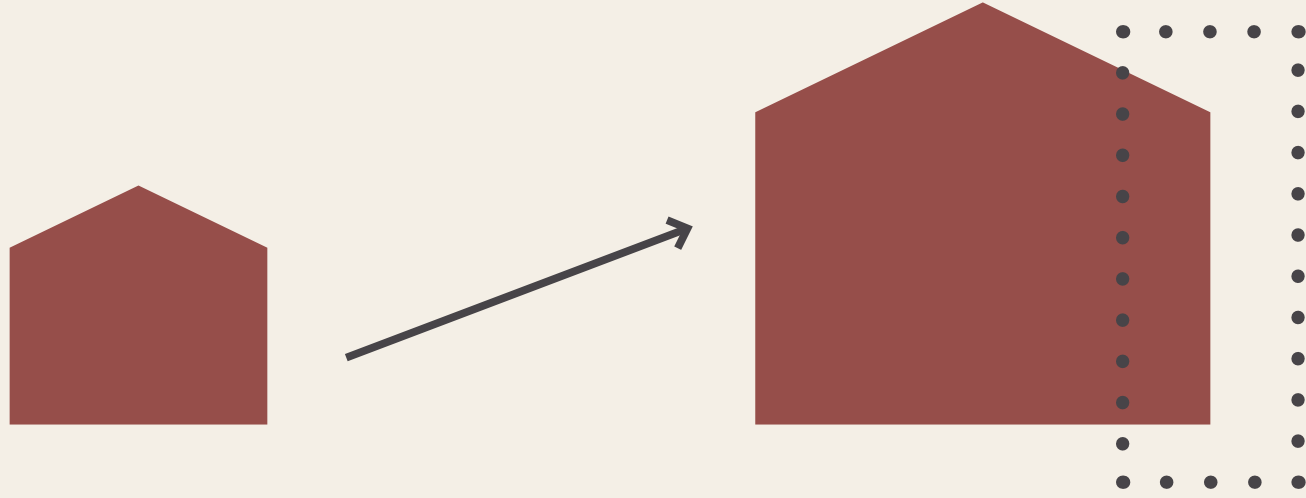

*Thank you for
listening!*



	Hours	Cost
New material - incl. transport	-	41 578 SEK
Reused material	-	18 100 SEK
Transport	-	Unknown
Ground work	-	17 237 SEK
Carpenters, EH	122 h	40 930 SEK
Architects, EH	2.5 h	1 313 SEK
Students - construction	286 h	0 SEK
Students - design & communication	175 h	0 SEK
Total:	585.5 h	119 158 SEK

Costs so far



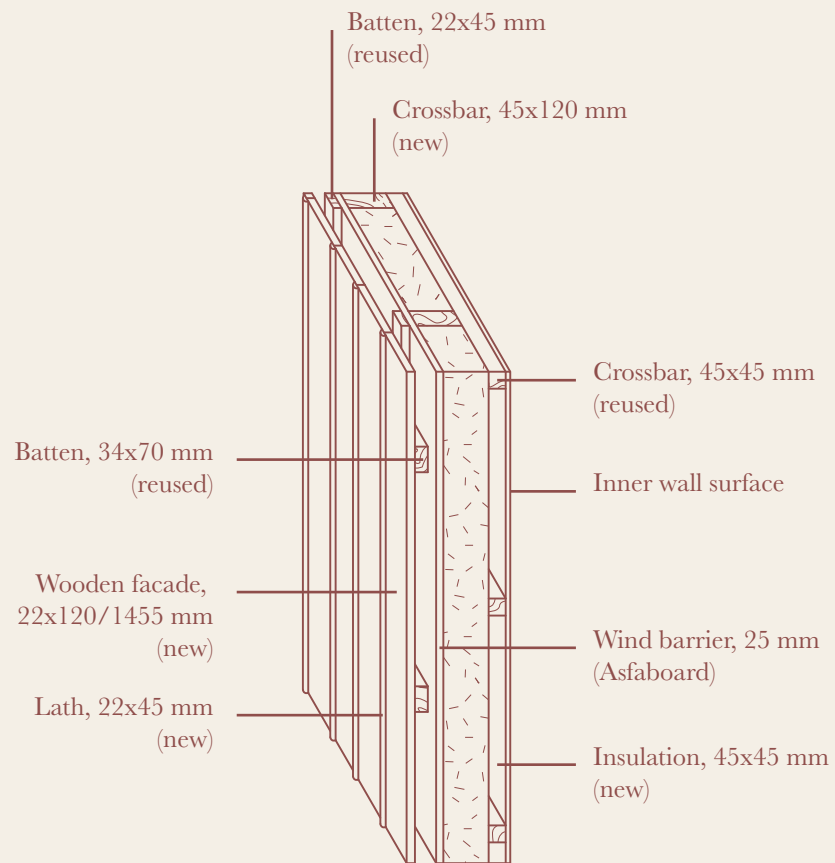

APPENDIX III

Logbook

Tidigare under projektet:

Samlat material till part 1 av rapporten. Skrivit och läst mycket om återbruk. Intervjuat folk som gett oss värdefull förståelse för möjligheter och svårigheter.

kommunicerat med Egnahemsfabriken kring hur vi ska genomföra projektet, hur vi ska få tag i en beställare och sållat bland intresseanmälningar.

Måndag 10/2

Skissande på planlösningar för en generell/okänd beställare. Skissade på en lösning med ett långsmalt hus med en bredd på max 3,1m för att kunna transportera på lastbil utan följevagn (pga extra kostnad) Det funkar men wc blir lite större än den behöver vara pga att bredden inte tillåter någon funktion bredvid wc. Det blir ett fungerande hus men vi skissar även på många alternativ med ett bredare hus som får bättre rum. Testade även vinklat hus som får transporteras i två delar. Det känns som att det skulle medföra ytterligare ett konstruktionsmoment som tar tid från vårt egentliga fokus på återbruk. Många planförslag blir det...

Ett Attefallshus på 30 kvm måste vara tillgänglighetsanpassat om syftet är permanent boende, annars behöver det klassas som fritidsboende om dessa krav inte ska gälla. Proportionerna på en tillgänglig toalett i ett så här litet hus passar inte. Mycket dödutrymme inne på toaletten, lägger hellre mer yta i det gemensamma utrymmet (där man kommer vistas och bo).

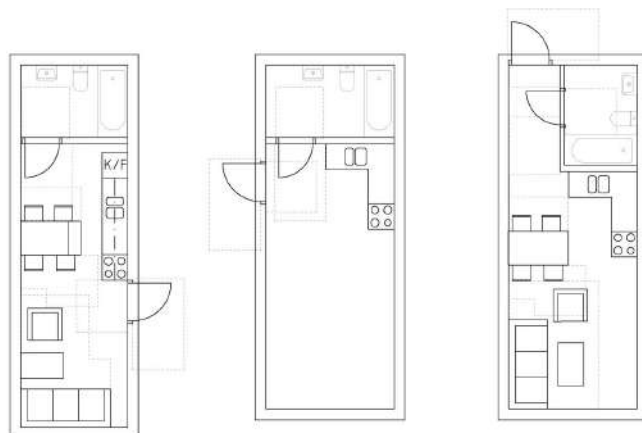

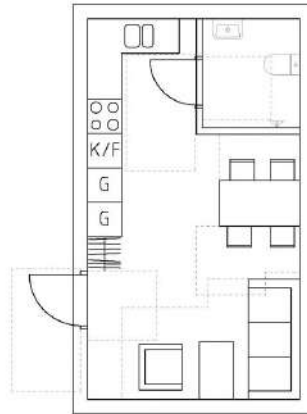
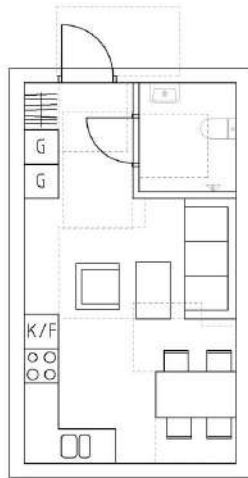
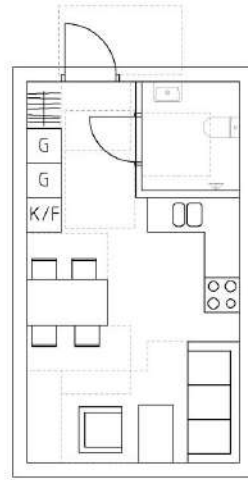
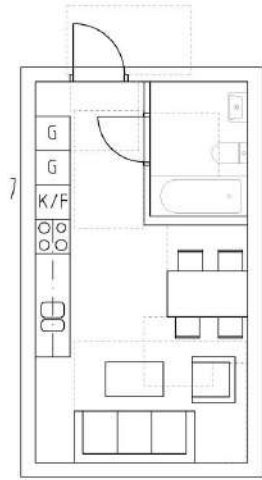

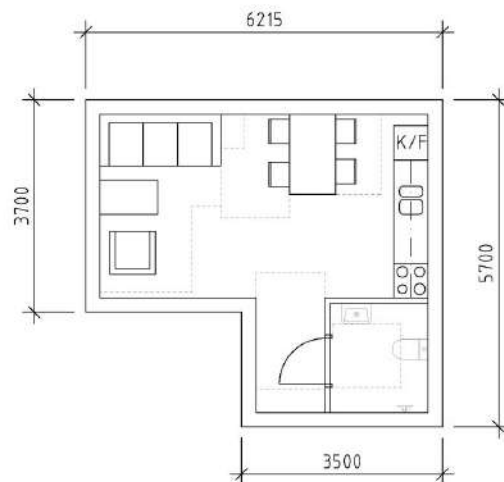
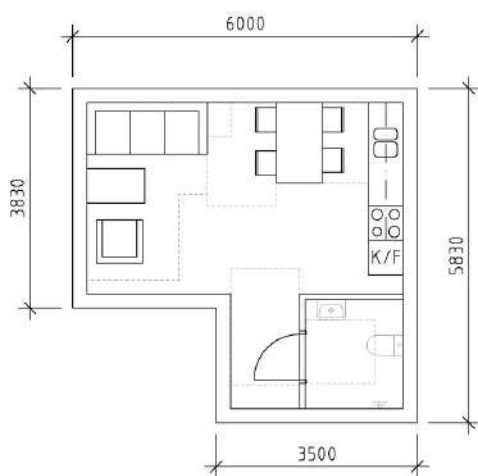
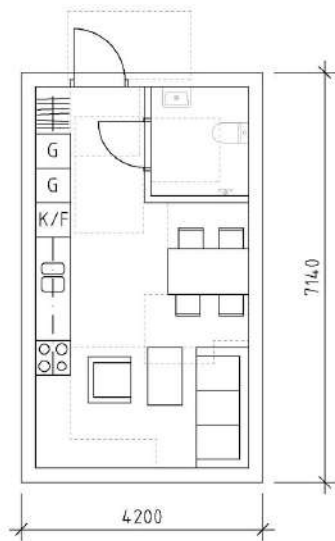

Tisdag 11/2

Förmiddag: Facetime med beställare. De var jättetrevliga och kändes väl införstådda med projektet. Det kändes som att de hade tänkt igenom allt och hade en tydlig budget. Vi diskuterade vår ambition med återbruk och de ramar som exjobbet ger i form av tid och engagemang. De vill ha ett eko och energismart hus på landet, med solceller på taket. Vi pratade mycket om hur de ville leva i sitt hus och vad som var viktigt för dem. De ville ha sovrum på bottenplan, alltså inget loft, men om de ändå behövde loft ville Sofia ha en ordentlig trappa. De gillar att laga mat så därför vill de ha ett rejält kök och

inte bara ett litet pentry. De vill hellre ha ett bredare hus och betala för följebil, vilket öppnar upp för bättre planer enligt oss.

Diskussion kring tak. De vill gärna ha sadeltak men förstår att pulpettak kan vara bra för att maximera solpanelerna.

Tillägg: Vid senare diskussion med solpanelsleverantör framkom att det inte var lönsamt att sätta solpaneler på ett så litet tak utan bättre att sätta de på ett av de större taken på gården, då de ändå finns tillgängliga. Detta skulle ge bättre effekt.

Intervju med Anna-Maria Blixt och Anton Franke (se sammanfattning)

De bekräftade mycket av det vi redan visste från andra intervjuer. Flera säger ovetandes om varandra samma sak och detta skriver vi om i Part 1 av rapporten.

Onsdag 12/2linus

Skissa på planlösningar till Linus och Sofia.

Handledning med John där vi diskuterade beställare och de intervjuer vi haft.

Vi känner att Linus och Sofia är "perfekta", men John tycker att vi ska intervju de andra också innan vi fattar ett beslut. Bra att få lite kött på benen.

L-format hus - hade behövt splitta huset vid transport. Medfört en konstruktiv och tidsödande utmaning som inte har med återbruk att göra.

Intervju med Christian Olsson, fönsterrestaurerare för kulturarvsbyggnader. Lärde oss jättemycket om fönster och hur fastighetsbranschen tänker kring fönster och byte av dem. Kort sammanfattning: Det kostar mer att restaurera än att köpa nya och sätta in, dock har de nya inte alls samma kvalité. Många fokuserar för mycket på att byta fönster för att huset ska bli mer energieffektivt men det hjälper inte att byta fönster om taket läcker värme som ett såll. Dessutom är det sällan i själva glaset som förlusterna finns utan i att karmarna är otäta pga dåligt underhåll. räcker det ofta med att sätta nya tätningsslistor m.m. Man kan sätta lågmissionsglas på insidan av gamla fönster eller lägga till en isolerkasett mellan två rutor. Upcycle studios fönsterkoncept är mer ett estetiskt uttryck för att visa att man återbrukat glas. Det är väldigt dyrt att låta en hantverkare tillverka bågar och karmar till glaset i så olika mått när de är oregelbundna.

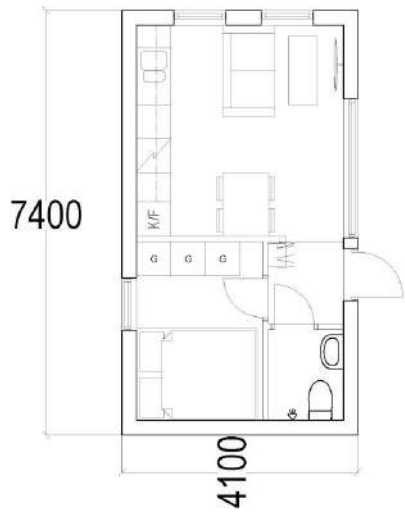

-VA på två ställen
 -Gå över smutslag zon till WC och sov
 + Bra rum, clean planlösning

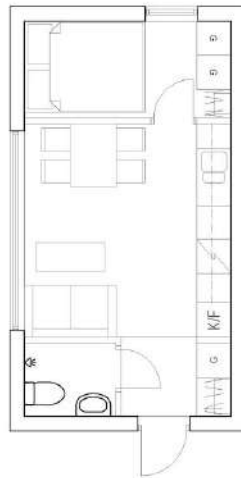

-VA på två ställen
 -Gå över smutslag zon till WC och sov
 + Bra rum, clean planlösning

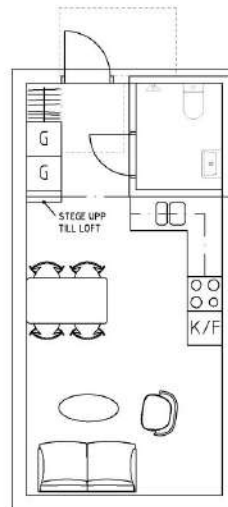
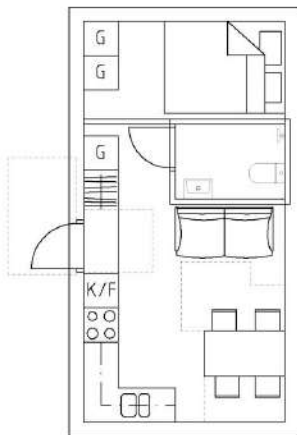
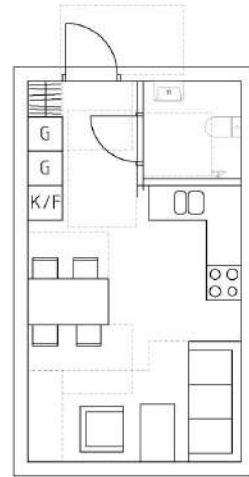



Torsdag 13/2

Viktigt att ha en beställare - är med och formar huset (planlösning, preferenser...)
Svårt att uppskatta mängd och dimensioner på konstruktionsvirke innan planlösning är någorlunda satt (efter kunds önskemål).

Miriam hade telefonmöte med Christian Wendesten, Ylva Berglund. Fick önskemål från båda och tog fram planskisser efter dessa.

Christian ska hyra ut sitt Attefallshus, som ska fungera som ett permanent boende - måste vara tillgänglighetsanpassat. Lite högre standard på toalett, vill ha tvättmaskin och trappan upp till loftet får gärna vara bekväm och mer permanent än en stege. Pengar inget problem.

Ylva hade inga direkta krav på sitt boende, skulle använda det som ett fritidshus på tomten. Inga tillgänglighetskrav, inget behov av dusch inne på toaletten. Väldigt öppen och lyhörd för våra åsikter och önskemål för att vi ska kunna få ett så bra examensarbete som möjligt.

Lite oklart kring ekonomin. Ska återkomma med budget.

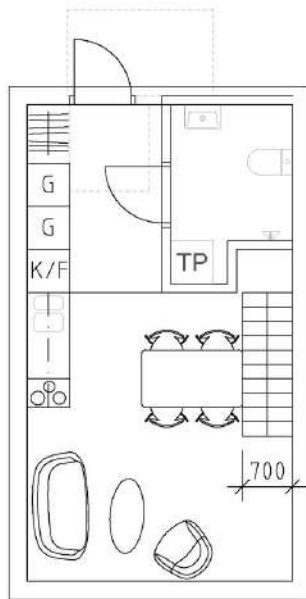
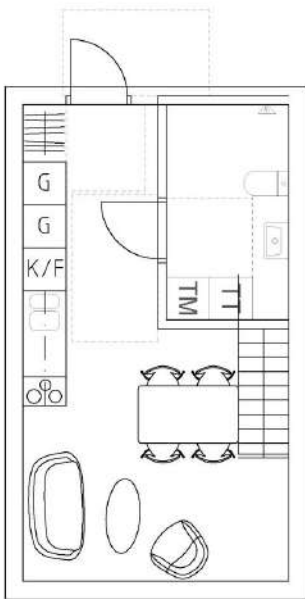
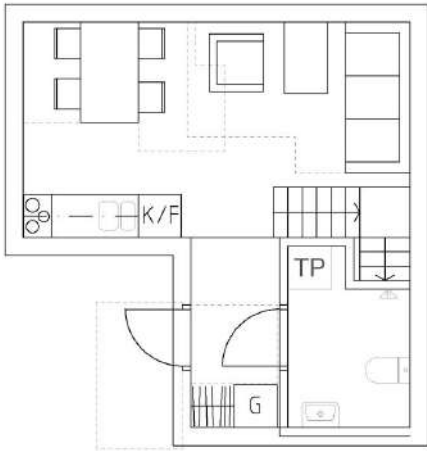

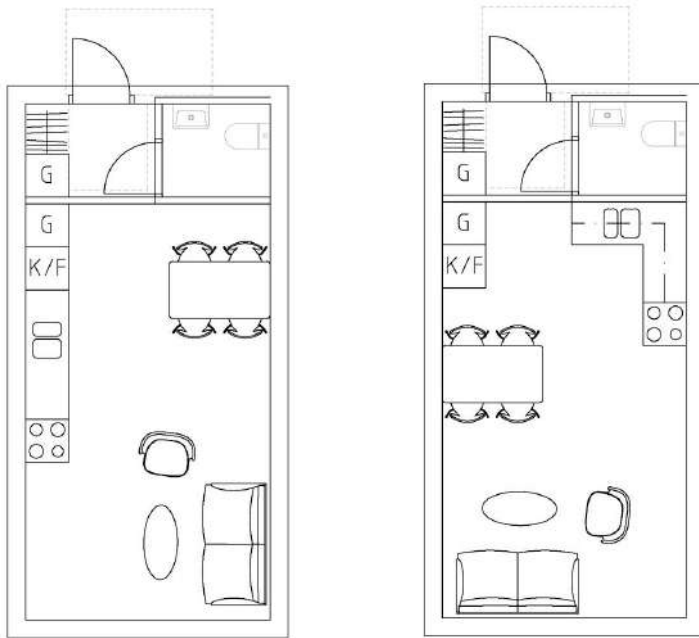

Fredag 14/2

Miriam pratade med Elisabeth Reuterberg, som hörde av sig. Hon drar sig ur då hennes man inte riktigt är med på noterna, tidsplanen är för snabb.

Att göra idag:

städa upp i CAD-fil

Mejla Linus & Sofia - planlösningar

- trångt med sovalkov
- större vardagsrum med sovloft

höra av sig till (finns restvirke?)

- Botrygg (Göteborg)
- Hansson & söner (Tjörn)
- Stenungsundshem
- Tuve bygg

Skanska har policy om att inte sälja/skänka överblivet material.

Valde ut våra favoriter bland alla planskisser och skickade dessa till Linus och Sofia för synpunkter.

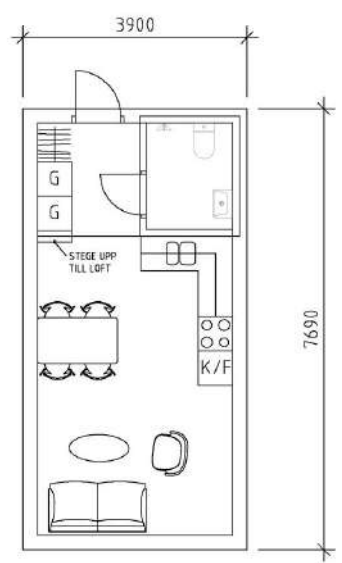
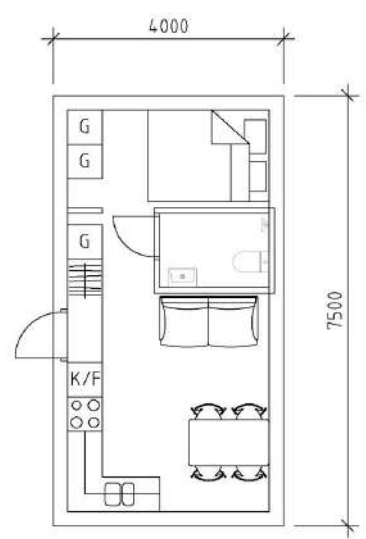
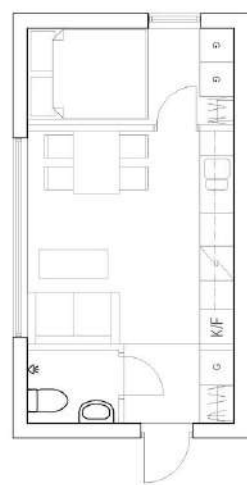
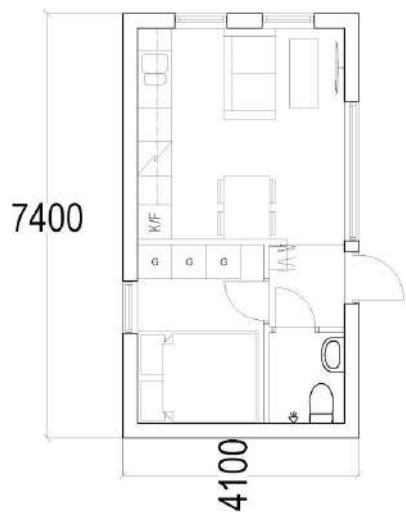

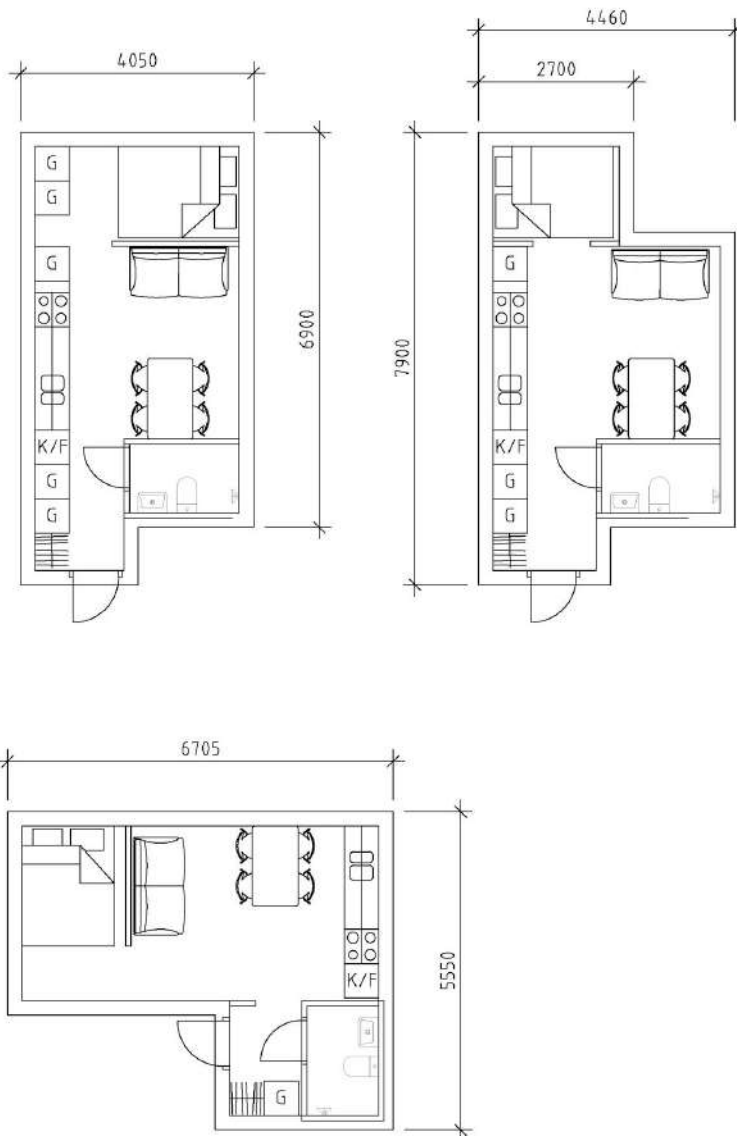

Söndag 16/2

Fick svar från Linus igår (15/2) angående skisser på planlösningar och de har kommit fram till att de inte vill ha sovalkov längre, tar för mycket plats, och istället förespråkar sovloft. Denna kan vara antingen i öst eller väst - långsida mot söder och norr. De vill kunna värma upp huset med braskamin, vill helst ha sadeltak då resten av byggnaderna på tomten har detta men funderar även på om asymmetriskt sadeltak kan vara något. Matplats i söder, kök mittemot och vardagsrum i nära anslutning.

Tankar kring att försöka få byggföretag att skänka restvirke - vi kommer kunna marknadsföra företaget, om vi får det gratis...

pilotprojekt - gör reklam, sälj in vårt projekt

när skrivs kontrakt med entreprenörer (elektriker, vvs, mm).

försöka få till en artikel i Arkitekten

Bestämt oss för Linus och Sofia, söndag 16/2

Blandning av planlösning 1 och 2 (kök i norr, toa & sovloft i öster).

Går det att få in en trappa? L-trappa?

Att göra mån-ons:

stomritningar

mängdberäkning

ringa Tinna/Erik och berätta vilka vi har bestämt oss för

mejla Linus och Sofia om beslut

ringa olika byggföretag om restvirke

Måndag 17/2

Att gå igenom på mötet med Erik (torsdag kl 11 på Tjörn)

- Projektavtal (genomgång av avtalsförslag innan vi skickar den till beställarna)
- Dina / era skisser och ritningar så här långt
- Budget (upprättande och genomgång av budget)
- Planering av projektet, genomgång byggplats, tider mm

Skissade nya planlösningar baserade på deras önskemål från helgen - kombinera de olika planlösningarna till fyra nya, med möjlig placering av braskamin (BS). De ville gärna testa att lägga in en trappa istället för att ha en stege.

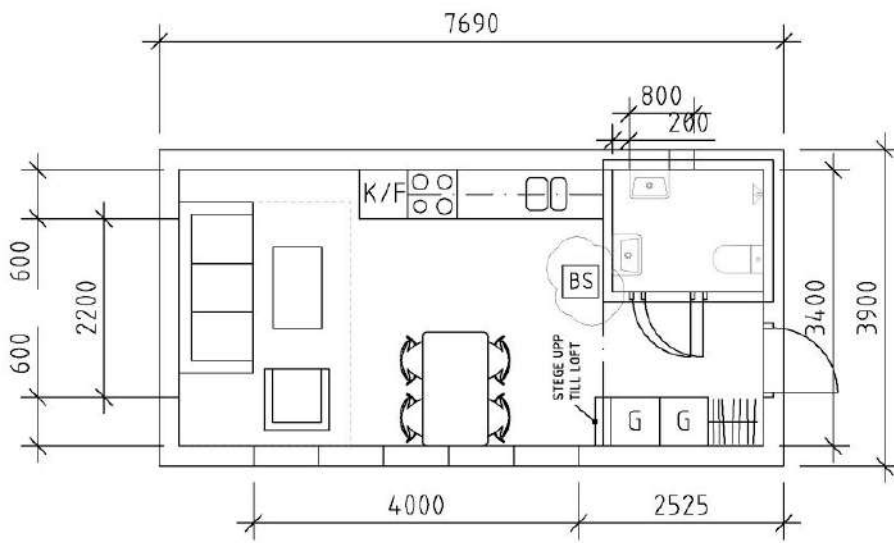
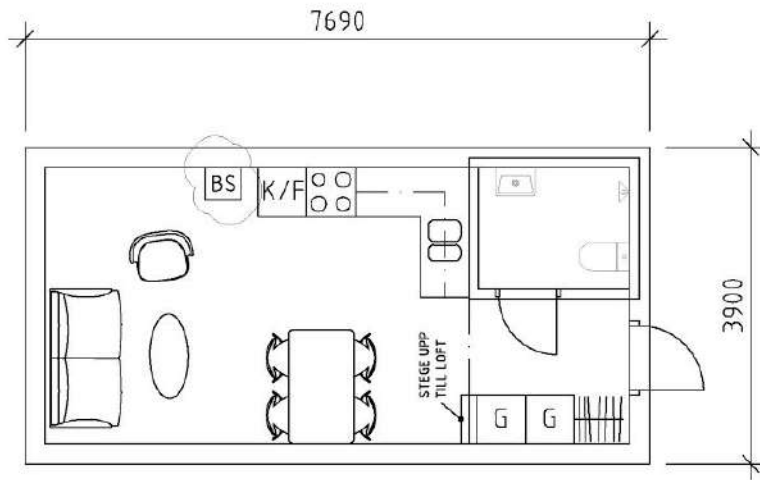

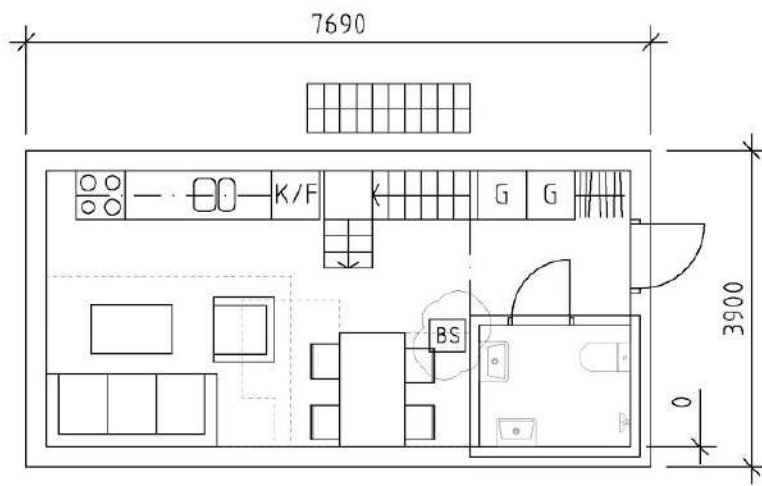
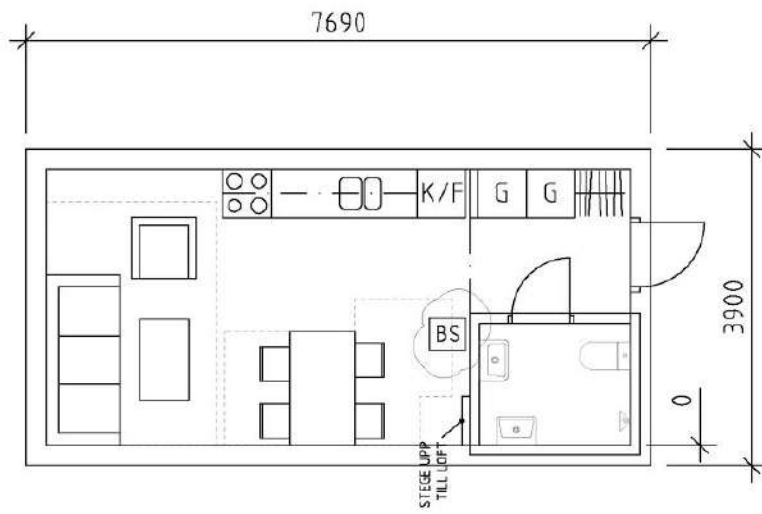

Tisdag 18/2

Mejlade olika byggföretag

Skissande på stomritningar (sektion, fasad). Testade två alternativ med pulpettak, varav det ena har sin högsta punkt åt söder (stora fönster) och det andra har sin högsta punkt åt norr (mindre fönster i söder). De tredje alternativet har sadeltak.

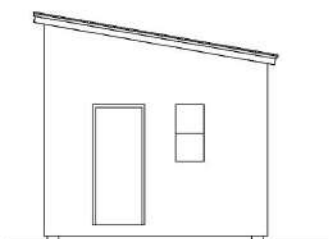
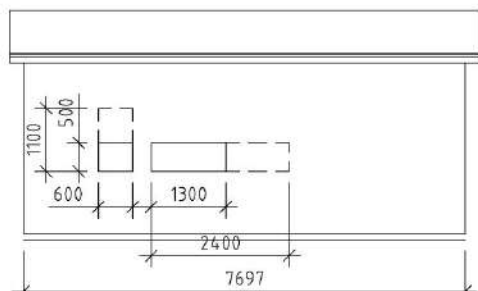
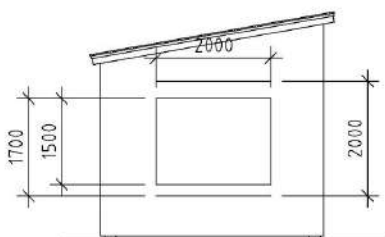
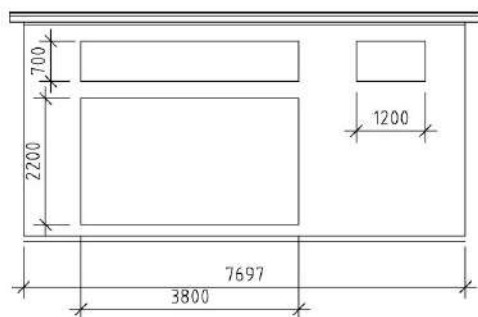

Fasad, alternativ 1.

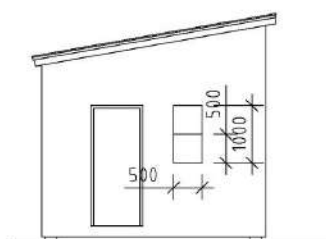
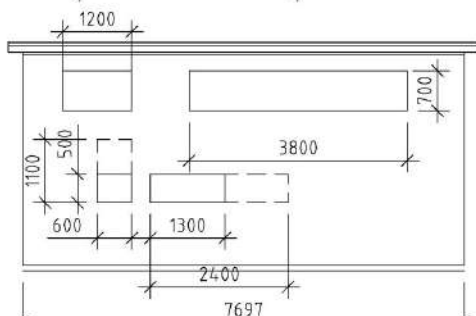
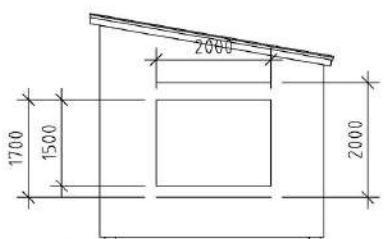
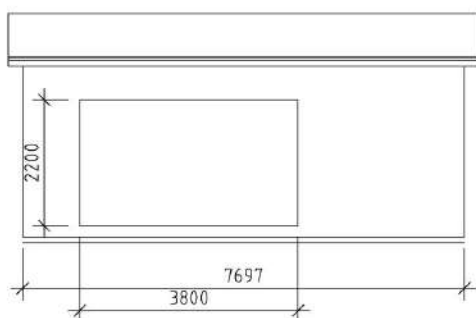

Fasad, alternativ 2

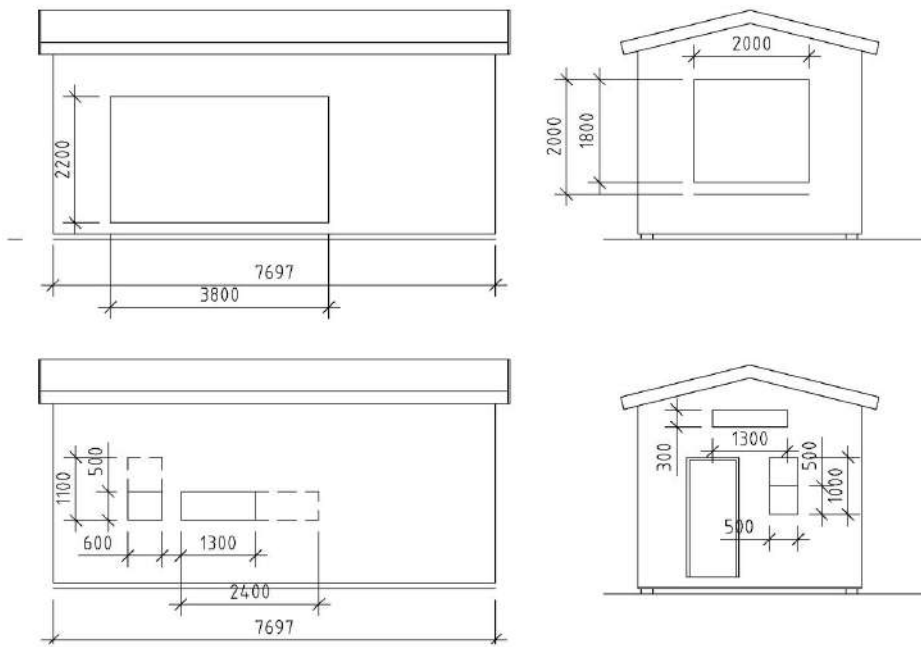

Fasad, alternativ 3

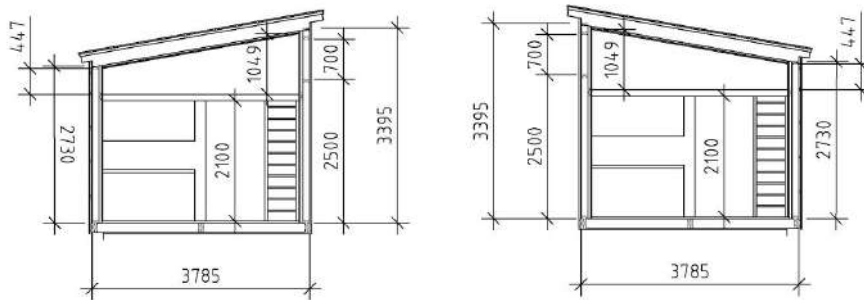

Sektion, alternativ 1

Sektion, alternativ 2

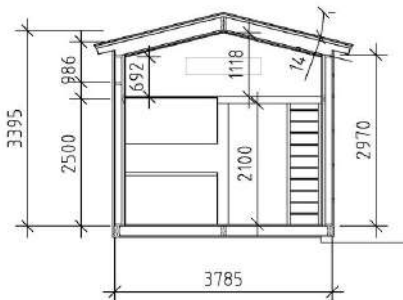

Sektion, alternativ 3

Möte med Linus och Sofia på Evas Paley i nästan 3h. Gick igenom planlösningar som vi valt att gå vidare med efter deras önskemål.

De höll med om att de inte är så smart att ha en permanent trappa då den äter upp mycket utrymme.

Något vi även diskuterade var takutformningen - sadeltak eller pulpettak. Om det ska vara pulpettak, åt vilket håll. Känns naturligt att ha den högsta punkten åt söder - husets framsida och stor yta mot söder. Dåligt ur solcellsperspektiv - högsta punkt åt norr istället. Ser konstigt ut? Glaspartiet åt söder kan inte vara så högt i detta fall. Sätta solceller på ett annat, större tak?

Onsdag 19/2

Skissande på stomritningar

Uppritande av olika varianter (entréplacering och takutformning) i Sketchup

Skickade iväg bilder och ritningar till Linus och Sofia.

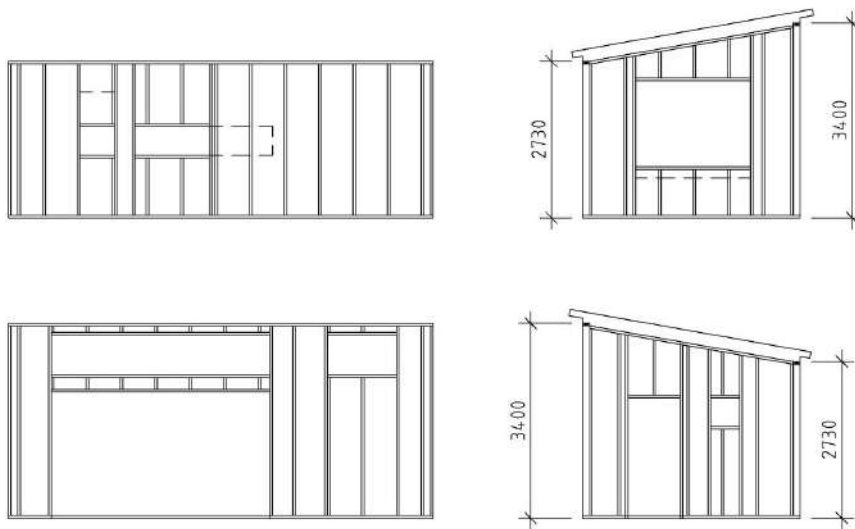

Stomritning, alternativ 1



Stomritning, alternativ 2

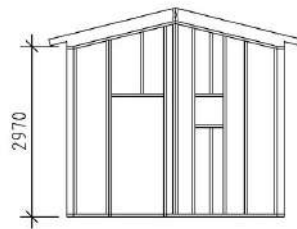
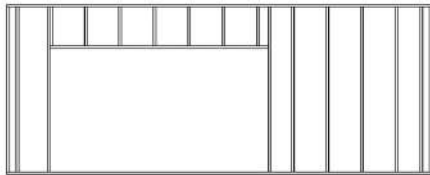
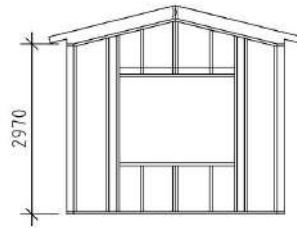
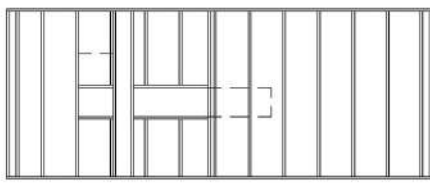

Stomritning, alternativ 3

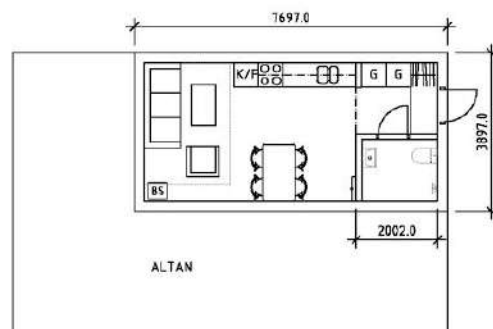
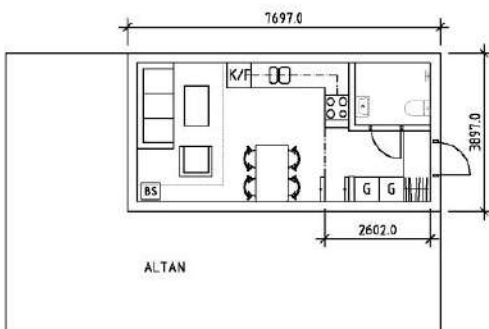
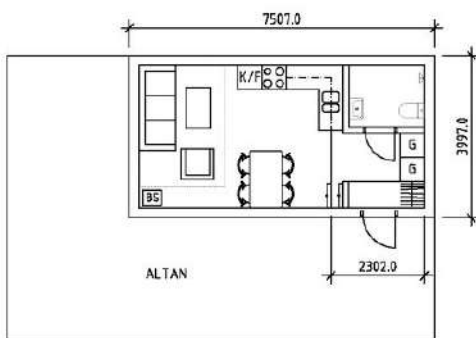

Planlösningar, uppdateringar efter mötet med Linus och Sofia.

Modellbilder - hus 1, alternativ 1

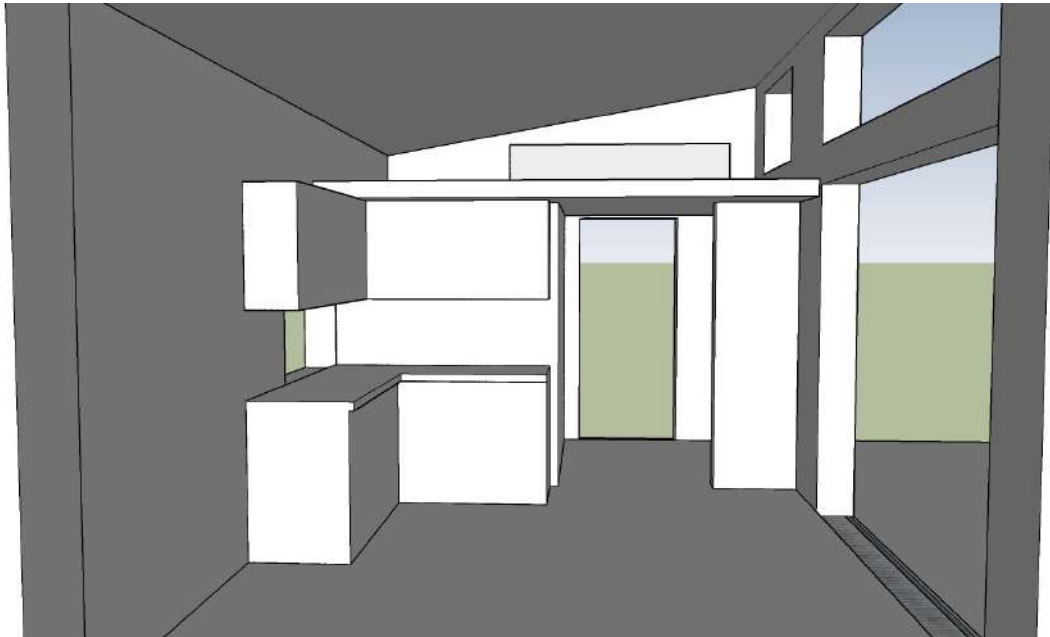

Modellbilder - hus 1, alternativ 2

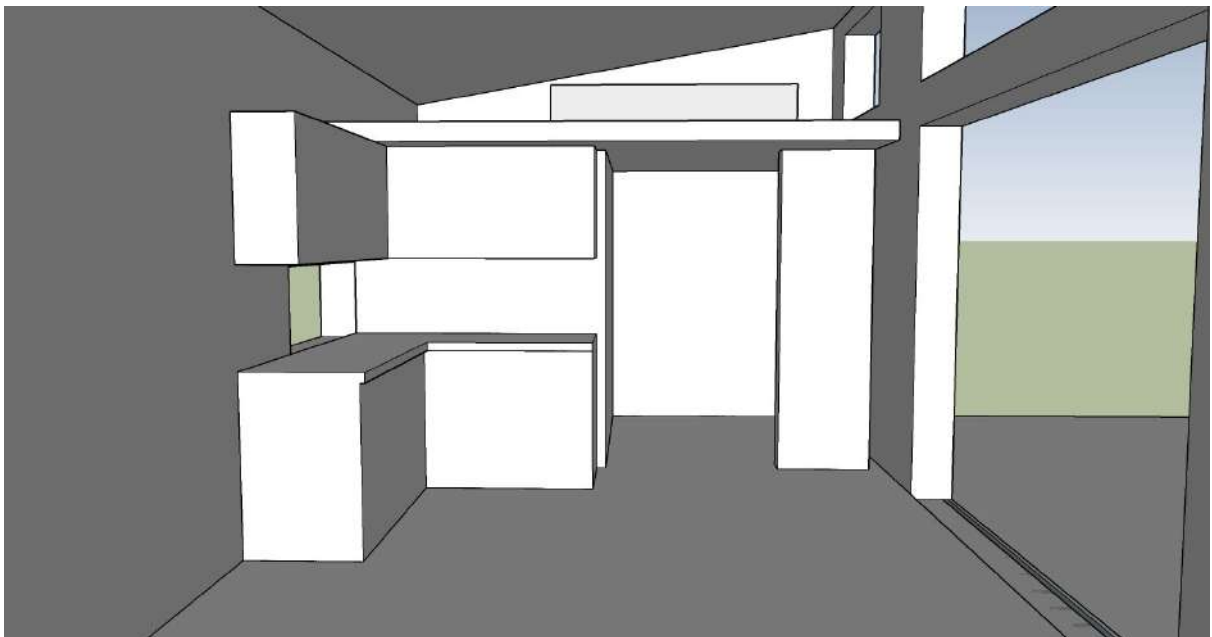

Modellbilder - hus 2, alternativ 1

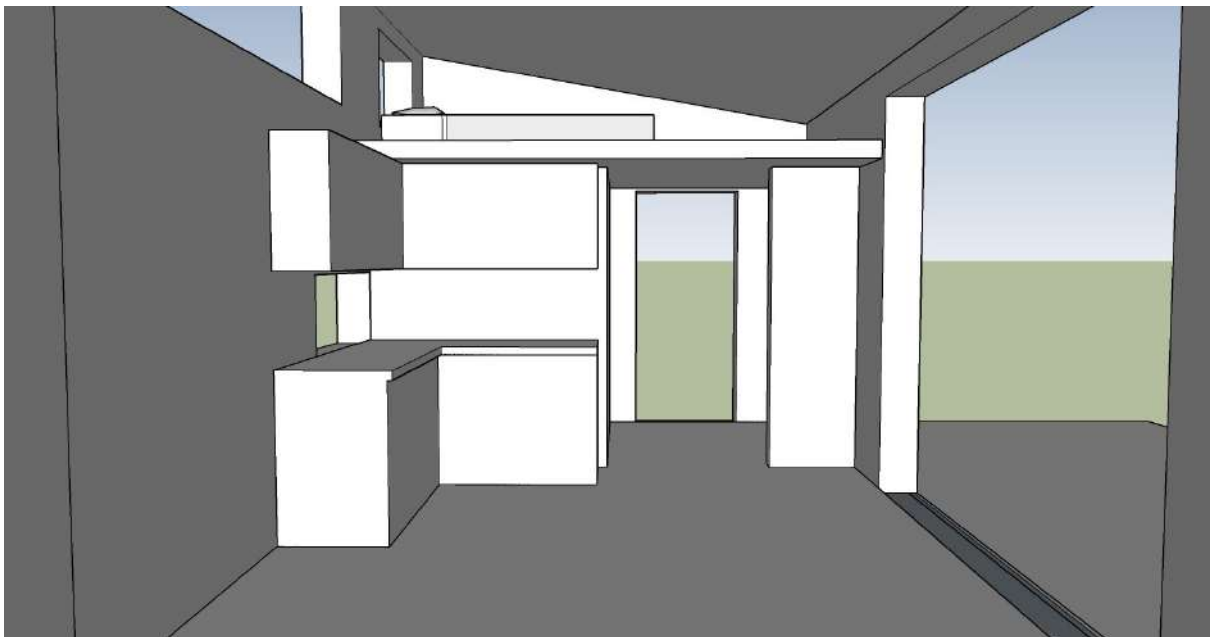

Modellbilder - hus 2, alternativ 2

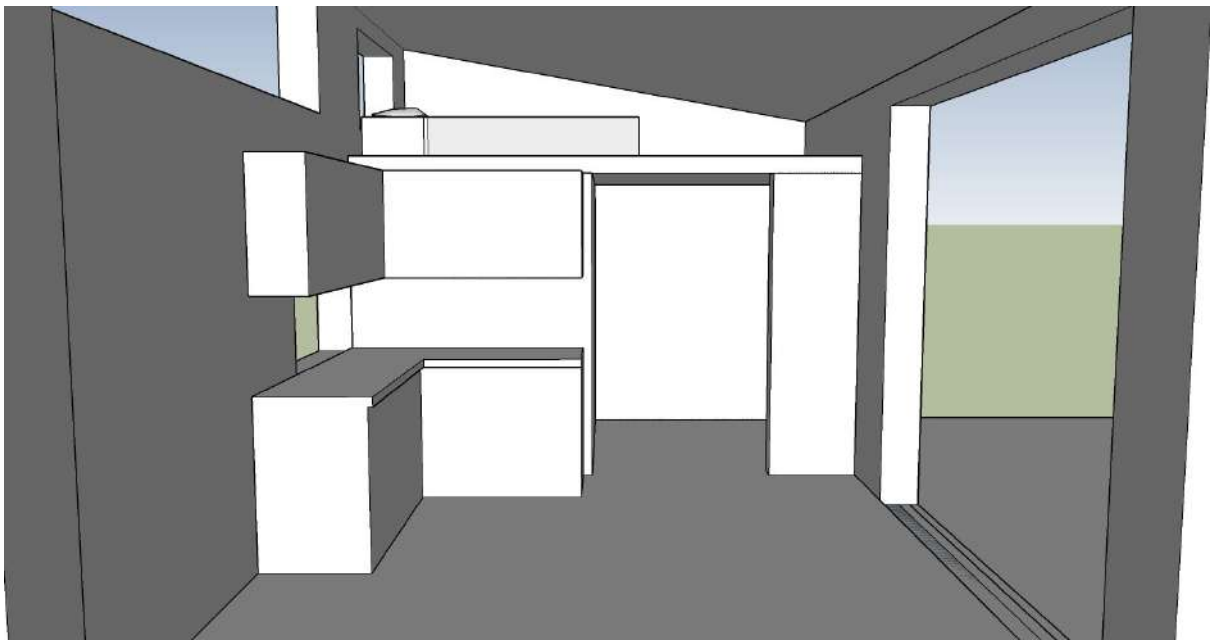

Modellbilder - hus 3, alternativ 1

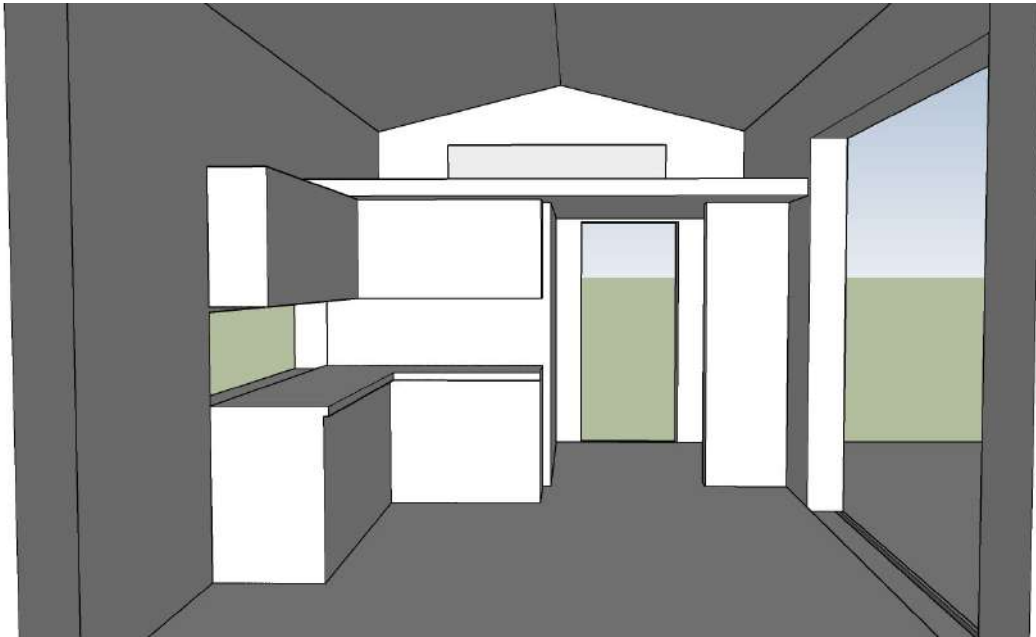

Modellbilder - hus 3, alternativ 2

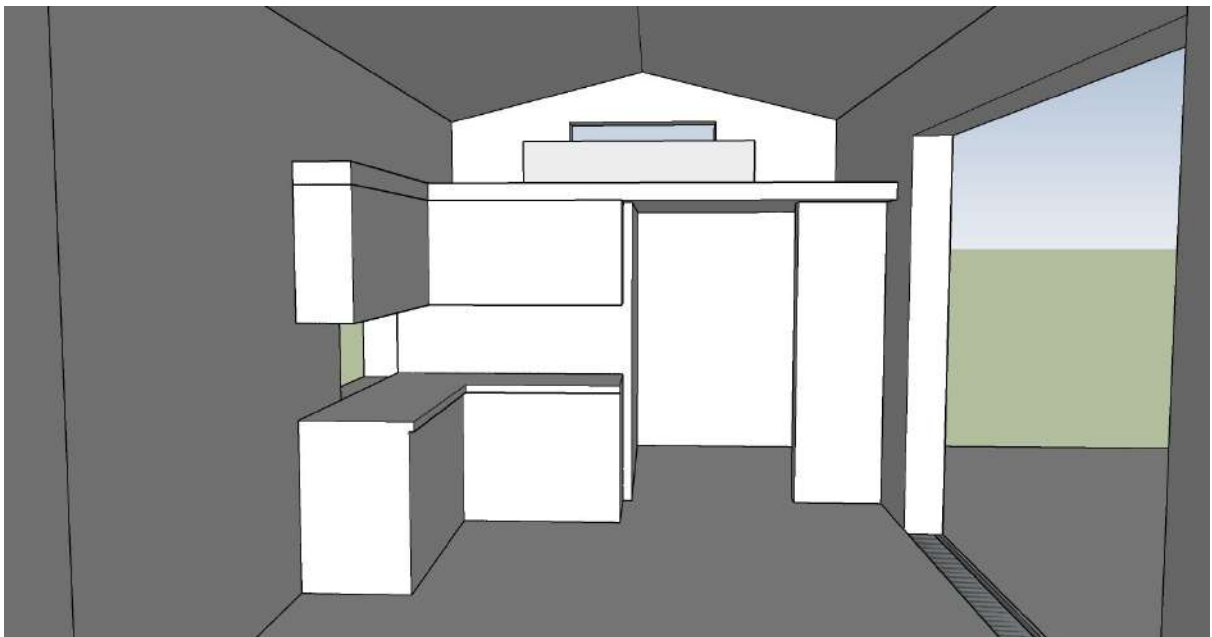

Torsdag 20/2

Möte på Egnahemsfabriken

Gick igenom avtal, budget och lite allmän info kring bygget och ritningar.

Träffade Christian

Mejlade Linus och Sofia lite frågor från mötet - fasadutformning och val av isolering.

Christian rekommenderar att sätta skivor i väggarna och spruta in resten, träfiberisolering. Alternativt om vi kan hitta restprodukter av mineralull.

Vi diskuterade bland annat solceller på taket och de på Egnahemsfabriken ansåg att det inte skulle bli lönsamt med solceller på taket på en såpass liten yta. Överväga att flytta till annan byggnad? I så fall spelar utformningen på taket ingen roll, fråga om smak.

Uppvärmning av huset tycker de att en luftvärmepump är ett bra alternativ.

Erik rekommenderade att göra huset tillgänglighetsanpassat för att kunna ha ett längre perspektiv - kunna sälja huset. Ska diskutera detta.

Linus har också varit i kontakt med en solcellssäljare idag och kommit fram till att solcellerna ska sättas på ladugården, som finns på tomten, istället för på attefallshuset. Däremot är de skeptiska till pulpettak, rädsla att utseendet blir för modernt och att det inte kommer passa in på tomten.

Har kollat på andra attefallsmodeller (nyckelfärdiga) och snöat in på brutet tak. Han vill ha mer rymdkänsla på loftet.

Vi är allmänt skeptiska till brutet tak. Får försöka övertala honom att det är en dålig idé, både vad gäller kostnad och tid men också utseende. Brutet tak = amerikansk lada.

Linus är allergisk mot mögel och vill inte ha någon isolering som drar till sig djur och mögel. Ok med restprodukt av mineralull.

Fasadmaterial har de inte tänkt så mycket kring, men färgen på husen på gården är vita och ladan är röd så linoljefärg i antingen faluröd eller vitt är ett förslag.

Har hittat en begagnad varmvattenberedare - för stor?

Fredag 21/2

Skickade planskiss till Erik

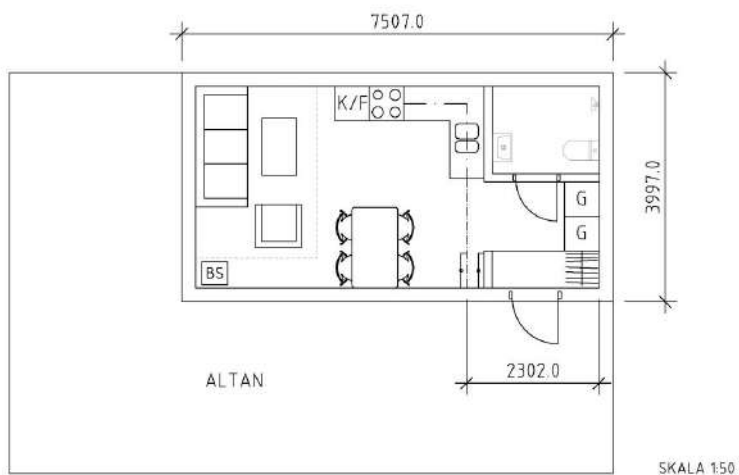

Det är svårt att göra en budget när man inte vet vilket material man har att tillgå. Då blir det svårt att bestämma hur huset ska se ut, tex yttre och inre ytskikt. Däremot kan stil eventuellt bestämmas och försöka hitta material som går ihop med denna.

Vad gör man om fasadmateriell finns att tillgå, men det inte räcker till alla sidor utan det finns tillräckligt för fyra sidor men typen är olika? Ska man göra fyra olika fasader? Eller två olika? Eller en och samma, men "tvingas" köpa nytt om det inte finns på plats/i närheten/som restvirke? Vad prioriteras i detta fall, återbruk eller design?

Även att rita upp fasader, och sektioner, känns svårt när det kommer till fönster och dörrar innan man vet vad som finns.

På mötet visade Christian en fil med material som finns på plats i nuläget, däremot är inte allt inlagt.

Måndag 24/2

Svarat Linus och Sofia (frågor om tak, isolering, planskiss). Bestämt att åka till Tjörn på tisdag 25/2 och torsdag 27/2.

Ritade upp en ny variant där badrummet är tillgänglighetsanpassat.

Måste fastställa planlösningen och försöka rita upp fasader och sektioner utifrån det material som finns i exceldokumentet. Det som inte finns måste "vi" köpa/hitta någon annanstans.

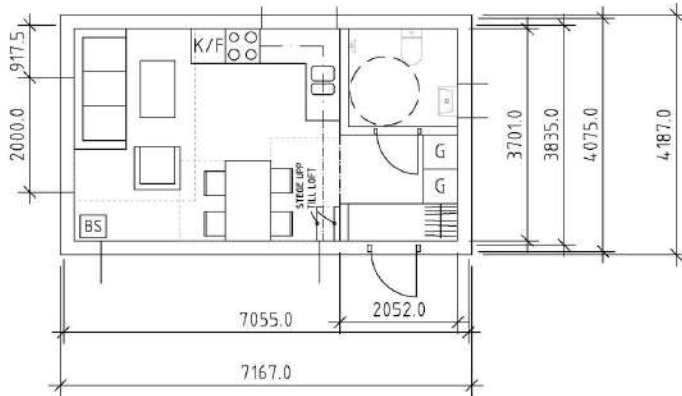

Stomritningar

Planlösning

(Fasadritningar)

Bestämma fönster och dörrar

Testade att sätta in fönster på fasader som finns på Egnahemsfabriken.

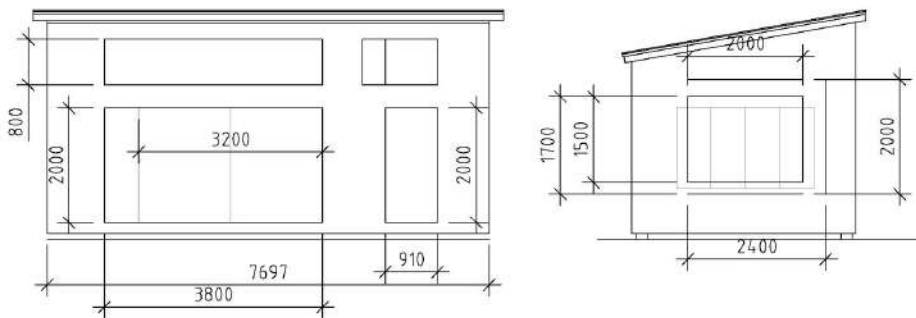

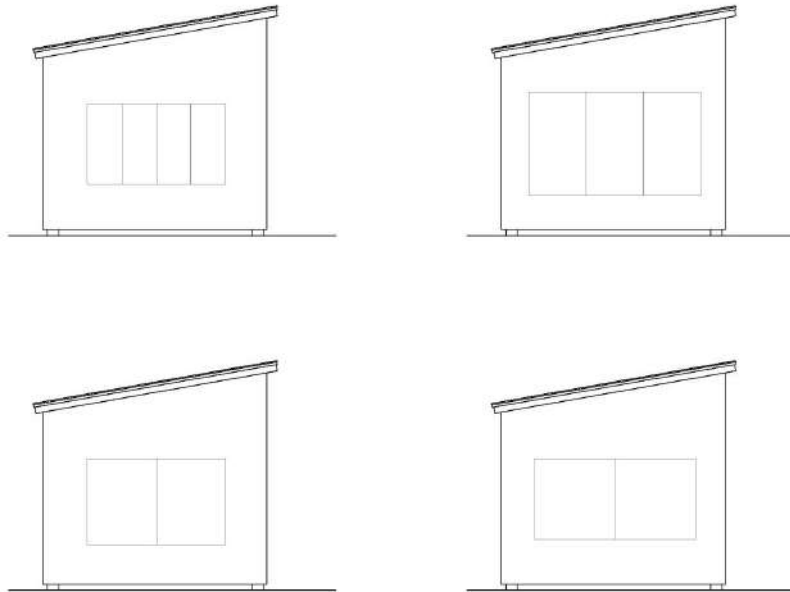

Tisdag 25/2

Diskuterade hur vi skall visa processen kring attefallshuset. Vilka steg är relevanta att visa i rapporten? Ida Röstlund kom förbi och gav råd. Vi borde göra en utförligare loggbok för projektet, då kan vi i efterhand se vart de viktiga besluten togs och vilka beslut det var och reflektera över dem. Vart finns vändningarna? Sedan ha med dessa viktiga vändningar och beslut i rapporten för att beskriva processen.

Hur vi gått tillväga hittills:

Först började vi skissa generella planer

- ingen följebil (bredd 3,1m)
- tillgänglighetsanpassat (svårt med 3,1m bredd)
- delbart?

Del 2

Därefter för Linus och Sofia, efter skypemöte

Gjorde även planskisser till Christian och Ylva, efter att ha pratat med dem och fått höra deras önskemål.

Linus och Sofia -

Bestämde oss för Linus och Sofia måndag 17/2. Skickade våra förslag, de fick välja ut sina favoriter. Utvecklade dessa och visade på personligt möte tisdag 18/2. Tog fram och presenterade de bästa

färg på fasad: faluröd eller vit (som resterande hus på platsen)

måndag 24/2 - bestämde sig för sadeltak eller brutet tak, valde bort pulpettak pga för modernt utseende.

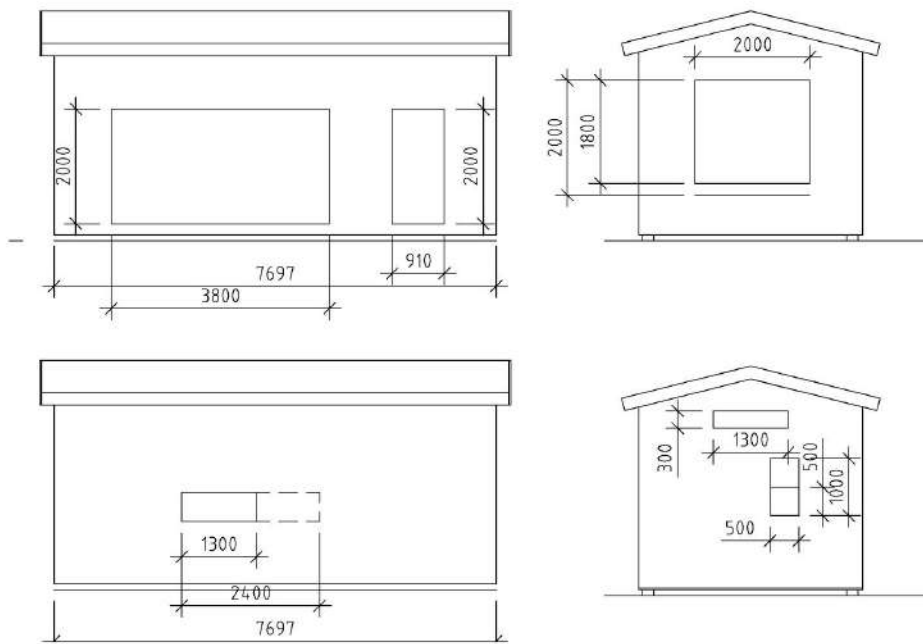

Fasader, öppningsmått (intervallmått)

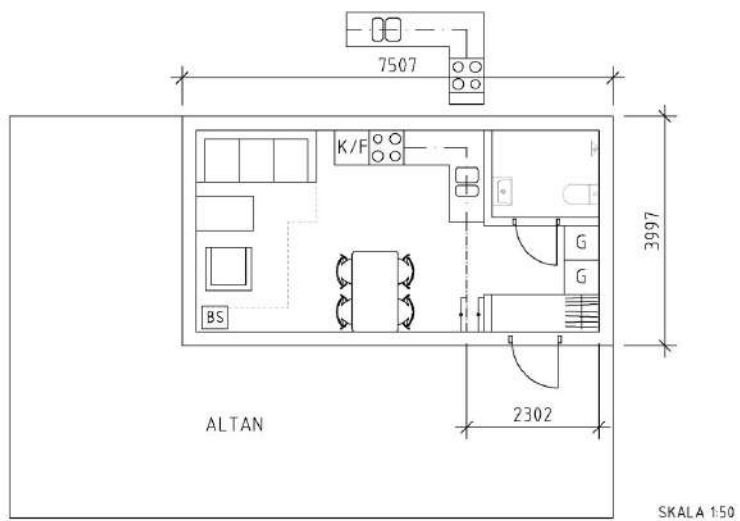

Planlösning

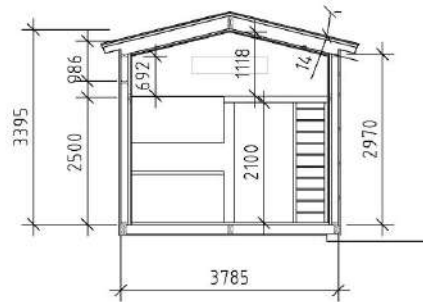
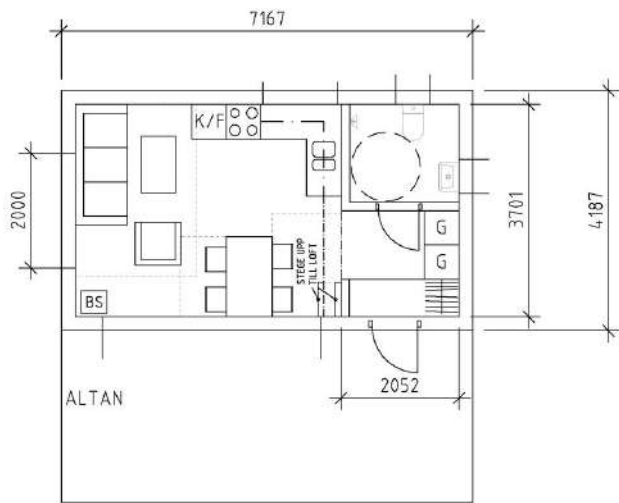

Planlösning, tillgänglig

Sektion

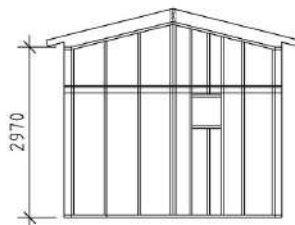
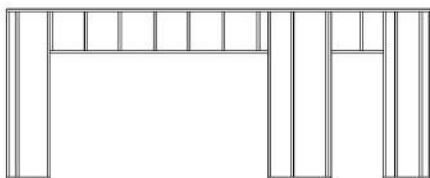
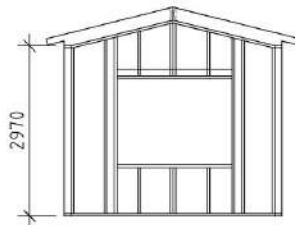

Stomritning

Test av fönster från Egnahemsfabriken

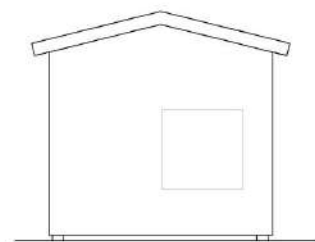
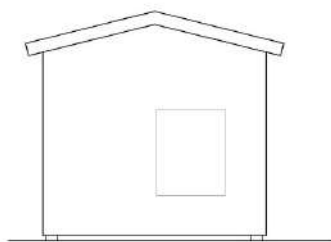
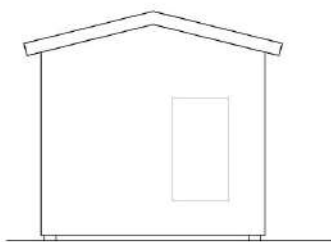
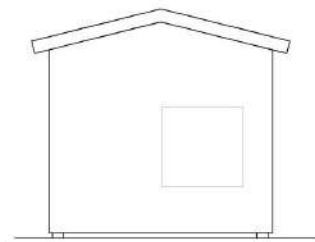
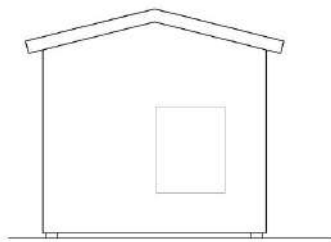
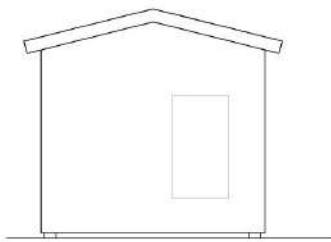
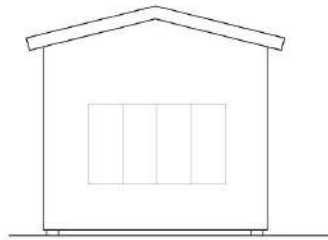
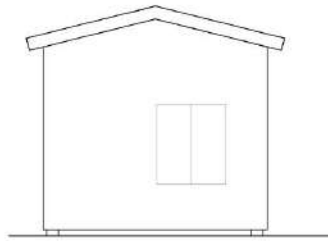
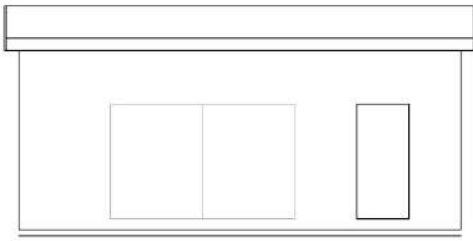

Onsdag 26/2

Fixade stomritningen inför möte med Egnahemsfabriken

Letade fönster på blocket och marketplace

Linus sa att de gärna hade haft gamla fönster med spröjs men att de såklart ville att huset skulle vara energieffektivt. Letade därför efter 3-glasfönster då Christian Olsson sagt att det är jättedyrt att få en fönsterrestaurerare att göra nya karmar, speciellt om karmarna ska ha olika mått.

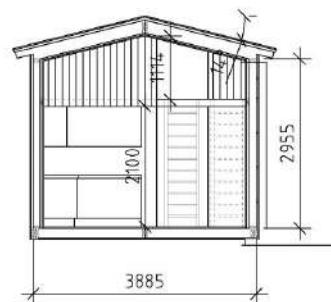
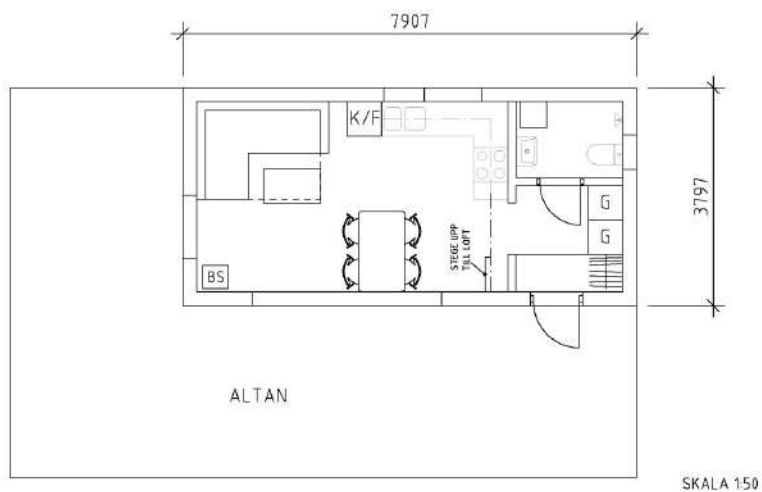
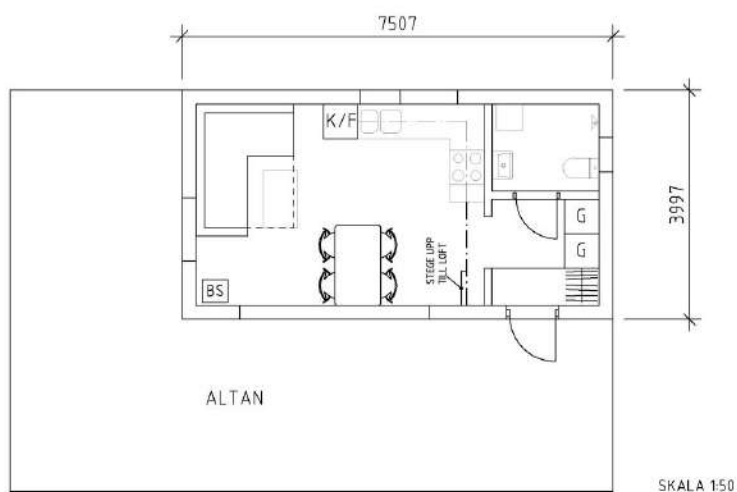

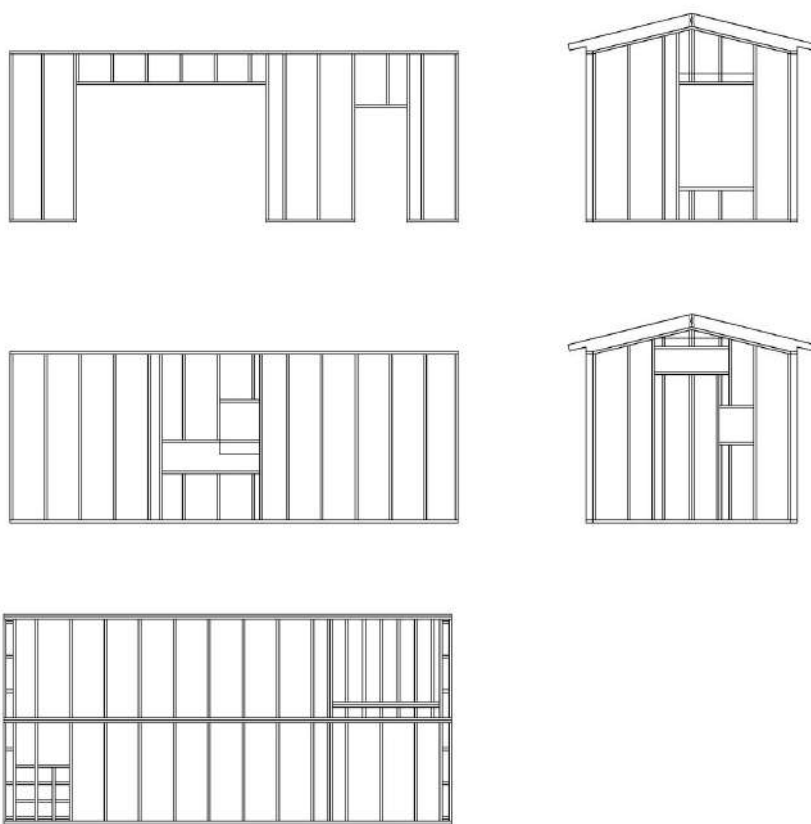

Torsdag 27/2

Åkte ut till Tjörn. Diskuterade fönster med John som gav oss nya idéer kring hur vi kan använda gamla fönster, vilket han gjort i sitt hus. Det gav insikt om att vi eventuellt missförstått Christian Olsson när det gällde priset och svårigheten med att göra nya karmar. Christian menade nog att det var dyrt att göra nya bågar och kramar till glastrutor, speciellt i oregelbundna mönster som i upcycle studios.

Träffade Snickar-Christian och diskuterade fönster, väggdetalj, takstolar och isolering. Isolering: Svårt att använda återbrukad/överbliven isolering då man inte vet vad den varit med om, vad för sporer det kan finnas i och att isolering lätt drar åt sig lukt som kanske inte upptäcks förrän man värmer upp det nya huset. Träull är att föredra enl. Christian. Det binds av polyesterfibrer (restprodukt, återbrukade).

Brandbekämpningsmedel av ammoniumpolyfosfat, som är ett naturligt näringsämne. Träfiber lagrar värme och fukt, och släpper ifrån sig när omgivande luft kan ta emot - hygroskopiskt material. Mineralull (stenull och glasull) gör inte detta utan risk att stommen gör detta istället. Träfiber är inte lika dyrt som hampa- och linfiber men har samma isoleringsegenskaper. Mineralull har bättre U-värde än träfiber men träfiber ger ett jämnare inomhusklimat.

Väggdetalj: För att slippa ha krysstag kan man använda asfaboard istället för ångspärr. Då riskerar man inte att ägaren gör hål i ångspärren när hen skruvar upp en tavla eller renoverar. Dessutom ger boarden skivverkan, vilket gör att man slipper använda krysstag i väggen.

Fönster: Man kan lägga en regel mellan fönstren som de gjort på attefallaren mitt emot ladan. Man kan också avlasta med en regel ovanför fönsterpartiet och då kan man göra hur stort fönster man vill och skruva ihop karmarna. Om man kan sätta en regel över eller ej beror på hur mycket plats man har kvar till taket.

Viktigaste i ett litet hus är täthet för god komfort, att det inte drar. Ett attefallshus på 30 kvm är nog för litet för att märka av värmelagringen i träfiberisoleringen.

Det är vanligast att man använder spikpistol vid byggen idag. Diskussion kring detta - för- och nackdelar.

Lim på spikarna i spikpistolen, gör att man kan minska diametern på spiken - ger ett nättare intryck. Jobbigt att ta ut dem då limmet skapar friktion när spiken skjuts in i virket.

Bra att skruva de olika skikten, om man gör fel. Enkelt att ta ut och göra om - *design for disassembly*.

Framtida användning av hela väggen? I nuläget använder man tigersåg och hammare för att ta isär väggar idag.

Vår tid är gratis vilket gör att vi kan ta oss tid att skruva, det kostar inget extra. Det är dessutom smidigt om vi gör fel, vilket är lätt hänt när man inte är rutinerad. Om en hantverkare skulle utfört samma arbete hade det inte varit ekonomiskt gynnsamt att skruva då arbetstiden kontra arbetskostnaden blir för hög.

Vi vet inte vilka behov vi kommer ha i framtiden och vilka fel vi hittar på produkter som byggs in idag. Alla tider har ju trots att dess teknik och material är bra. Naivt att tro att vi är framme och inte hitta fel på det vi bygger idag. Detta gör att det är viktigt med *design for disassembly*. Plintgrund är bra ur den aspekten - man kan flytta huset.

Kanske borde hitta något ekologiskt alternativ till asfaboard?

Eventuellt inte snyggt att skruva fasadpanel? Stora skruvhuvuden? Nätt med spik, syns knappt.

Möte med Tinna, snickar Christian och John på Egnahemsfabriken. (Se anteckningar från mötet.)

Diskussion kring tidsplanering. Christian ska kolla med Derome om de har tid att leverera färdigkapat virke (FKS) till nästa vecka. I så fall behöver vi göra en stomritning i 3D i Sketchup.

Mer pedagogiskt att se huset byggas på bjälklag, bygga alla väggar hela, istället för att bygga i moduler.

Vi ville helst ha överblivet virke för att det skulle kännas mer äkta i projektet men det tar lång tid för byggföretagen att få in materialet från olika byggen i landet så det kommer vi inte att hinna. Stomme och takstolar får därför vara byggda av nytt virke i detta projekt. Tidsplaneringen är A och O och tid är något som behövs vid återbruk.

Faktorer som gör att virket på stommen och takstolarna måste vara nytt:

1. tidsbrist i projektet
2. klassning av virke, konstruktionsberäkning.

På bussen hem kommer vi fram till att det känns viktigare att hinna göra fönsterlösningar än att leta överblivet virke och såga stommarna själva. På vägen hem kollade vi på Johns hus där han satt ihop flera fönster med egensnickrade karmar. Detta skulle vi vilja testa att göra. ska kolla med Linus och Sofia vad de tycker om idén. John påpekar att beslagningen är viktigt att den är lika för att ge en sammanhållen stilmässigt hela huset.

Gamla fönster har bra kvalité, enkel konstruktion - anledning till återbruk. Kopplade fönster ger gammaldags intryck.

Fönster präglar uttrycket mycket, fönstren är husets ögon.

Valet att ha färdigkapad stomme kommer ge oss mer tid att kunna fokusera på att göra fönster och egna karmar, och verkligen förstå hur man kan jobba med fönster som uttryck. Istället för att lägga tid på att själva såga virke till stommen.

Fredag 28/2

Vidare undersökningar av fönster. Svar från Christian Olsson på LinkedIn:

Elin: 1. Det finns mängder med vita aluminiumfönster på blocket. Går det att som lekman spraya om utsidan på aluminiumfönstren så att de kan få en annan enhetlig färg?
2. Sedan finns det ju en massa gamla fina enkelglasfönster med trækarm. Går det att sätta dem två och två (ett på insidan och ett på utsidan) för att få bättre isolering? eller blir det väldigt dålig isolering oavsett?

Christian: Japp man kan måla om aluminium. Se till att få rätt färg (fråga i färgbutiken) samt ha ett rent fast underlag. Ta bort lös färg och tvätta av med målartvätt eller dylikt.

Elin: Sätta ihop karmarna tänkte jag nog, Men går det att sätta ihop bågarna också om man inte vill ha dem öppningsbara?

Christian: Det går att sätta ihop bågarna och göra vanliga kopplade fönster. Viktigt är att det är luftning mellan bågarna och tätt inåt.
Sätta ihop karmar funkar också. Men viktigt med samma princip där. Kan även passa på att lägga lite fönstervadd mellan bågarna som tar upp eventuell kondens som kan uppstå.



Fönstervadd kan hjälpa om fönstret inte är tillräckligt tätt och kondens uppstår som i vissa av Johns fönster där tätlisten inte lyckas hålla tätt.

Samtal med Linus på facetime angående mötet med Egnahemsfabriken på torsdagen.

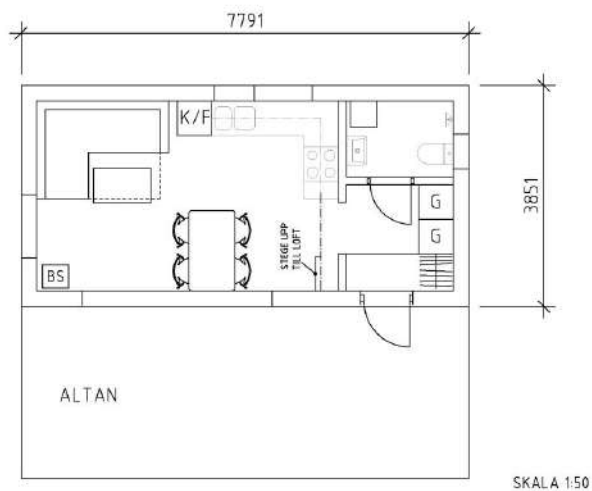

Uppdaterad planlösning med tjockare väggar, efter möte med Christian (Egnahemsfabriken).

Linus vill gärna att vi testat lite brantare taklutning för att minska på fasadernas höjd. Samtidigt som vi tänker att man inte vill ha för brant tak för att skapa mer yta på loftet.

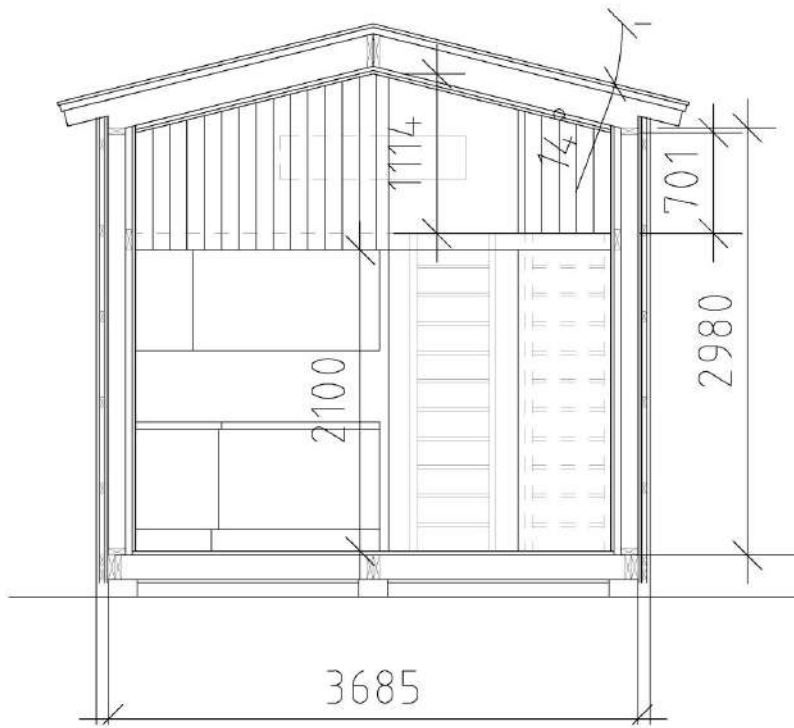

Sektion, 14 graders taklutning



Sektion, 18 graders taklutning

Söndag 1/3

Kulturarv = åka längre, nu i närområdet. dyrt med kulturarvsfönster.
Ev göra ett fönster med egen karm till presentationen, för att testa.

De vill ha 800 bröstning, vi får övertala dom till 600 pga stämmer bättre med ytterdörren.

Vi behöver argumentera för det vi vet bäst. Inte låta dem bestämma för mycket. De ändrar sig mycket fram och tillbaka vilket borde reflekteras över då saker man hittar på blocket och marketplace inte finns kvar när man väl bestämt sig. Påverkar processen och designen.

Ett alternativ är att hitta smala fönster som är lika höga/breda som de "stora fönsterna" som man sätter över dem - skapa överljus.

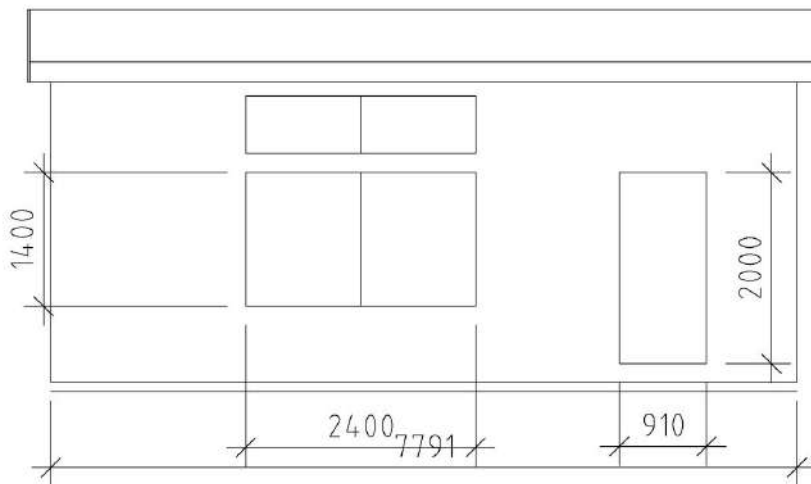

14 grader

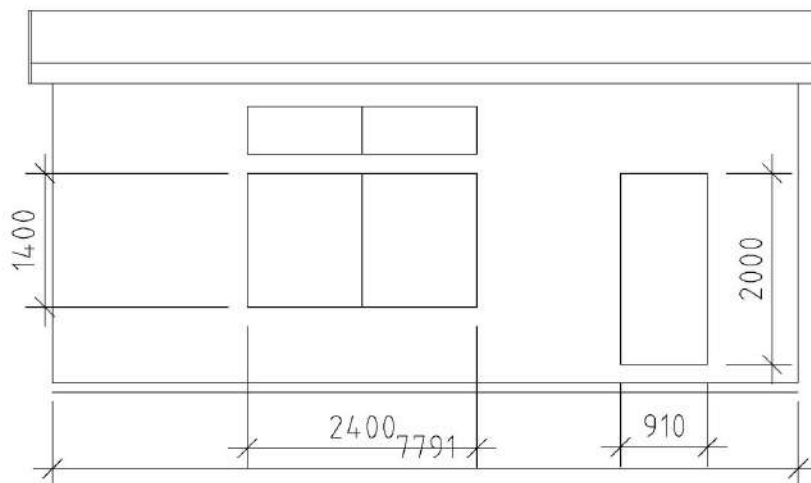

18 grader

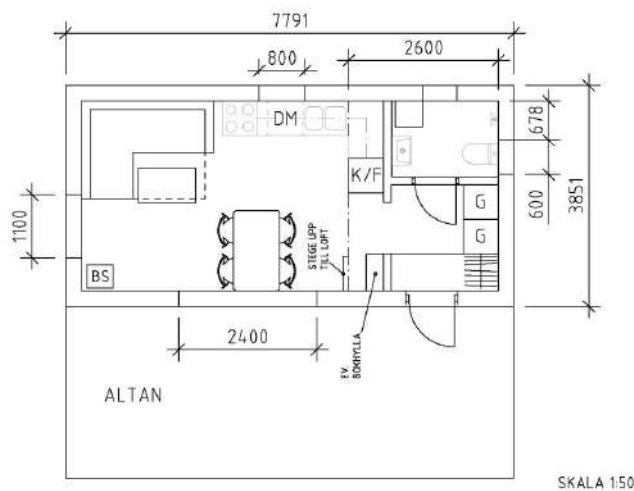

Tidsaspekten på vårt projekt: attefallshus på semestern.
Stommen är i trä och har inte så stor miljöbelastning - ok att köpa nytt virke.

Måndag 2/3

För att kompromissa mellan 14 och 18 graders lutning på taket gjordes en ritning med 16 graders taklutning innan mötet med Sofia och Linus.

Linus vill ha brantare taklutning för att minska fasadens höjd, medan Sofia vill ha en flack lutning för att ha så mycket höjd som möjligt på sovloftet. Vi håller med Sofia i detta och behöver få med Linus på tåget.

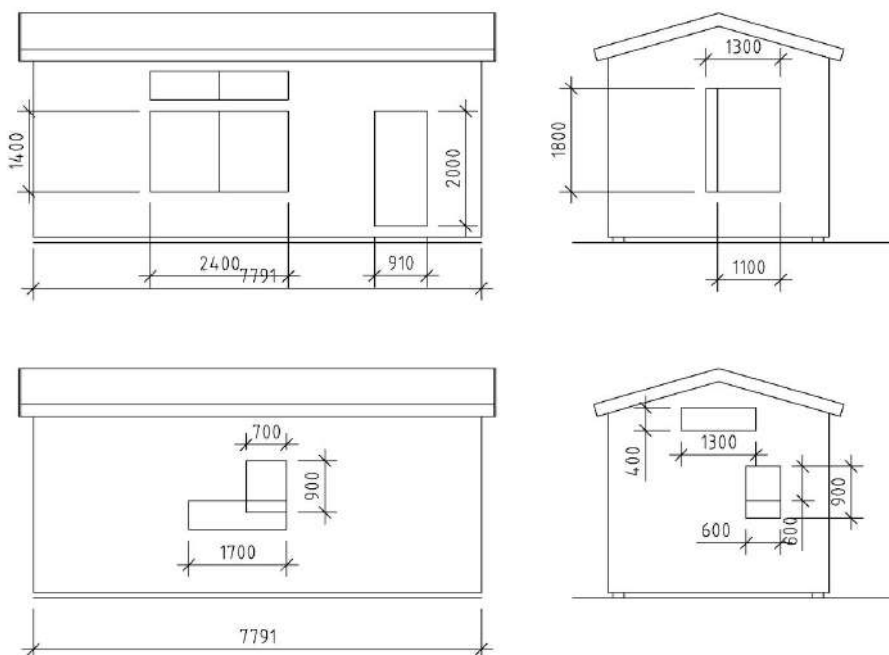

Fasad - 16 graders taklutning

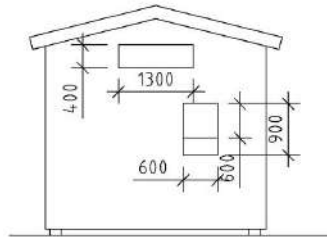
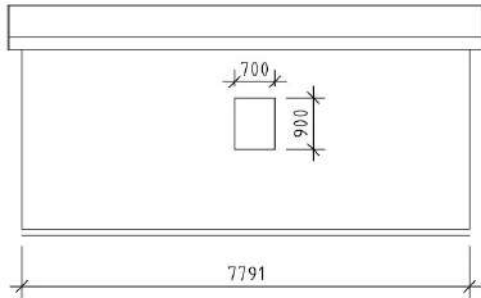
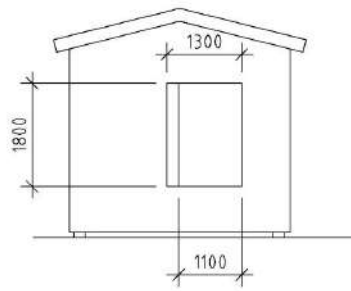
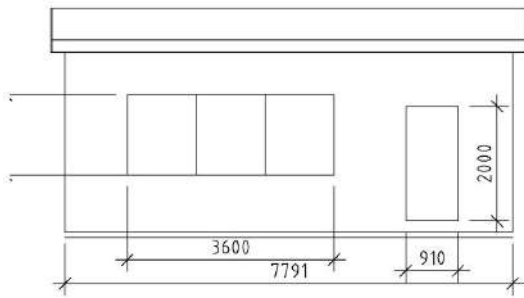

Fasad - 14 graders taklutning

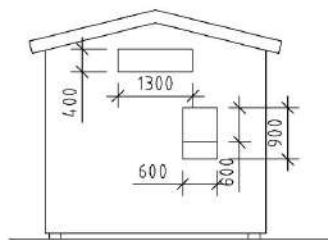
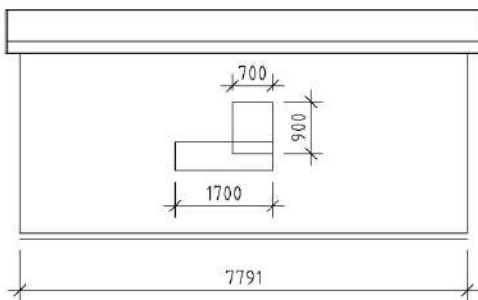
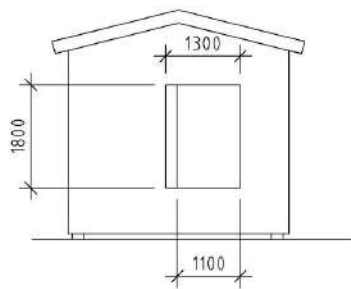
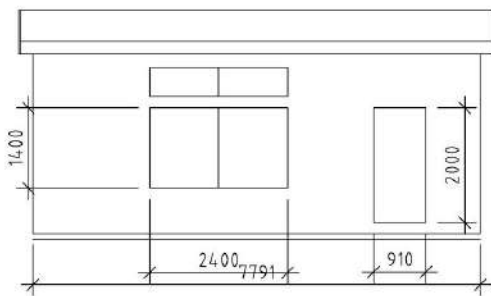

Fasad - 18 graders taklutning

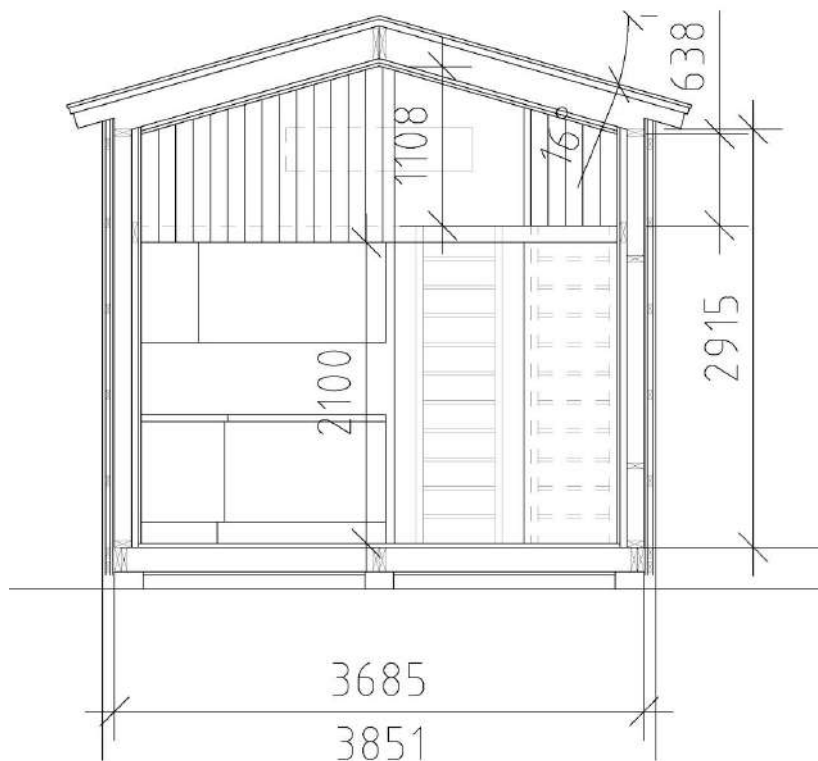

Sektion - 16 graders taklutning

Reflektion om beställare

Det är ett hantverk att ha kundkontakt och en hårfin gräns mellan att inte ge kunden spelutrymme för velande men att de fortfarande känner sig tillfrågade och involverade, samtidigt. kunden vet inte riktigt vad den vill ha, det är arkitektens jobb att guida och vägleda. Kan snöra in på något som inte blir bra i verkligheten. T.ex Linus har fått för sig att brutet tak är bäst för att han vill ha lägre fasader och att taket skall synas som om taket hade en större vinkel som på de omgivande taken (30 resp 40 grader). Det blir fult, amerikanskt och ger de facto mindre utrymme på loftet.

De vill ha ett traditionellt utseende men ett brutet tak skulle se amerikanskt ut och inte halländskt. det blir lätt att de snörar in på saker

I början hade de inga åsikter om stilen eller enskilda saker men ju längre tiden gått och ju mer de funderat så har mängden åsikter varit exponentiell. Att de i början gav intrycket av att de inte spelade så stor roll var vi slarviga med att visualisera och argumentera för våra åsikter, På mötet söndagen 1e mars fick de se en 3D modell i Archicad och kunna se live när man ändrar till olika bröstningar och stilar på fönstren vilket gjorde att de förstod våra åsikter lättare. De fick även se referensbilder på olika fönster som vi föreslår vilket gjorde diskussionen lättare och lättare att argumentera från vår sida. Tidigare har vi kommunicerat via facetime och skickat bilder och ritningar, lite naivt av oss att anta att de kunde visualisera och läsa ritningarna. Det är en ganska unik färdighet för folk i byggbranschen.

linus:

(Sittna biljetterna på Jokus fönster)

- Föreläsa vad Christian sa om trävill
= löst/sporer i gammal isolering.

- Tänkvar kring trä

- — " — isolering

- — " —

Ärka isoleringar i samhus.

- Onsdagsbrisader, kan de hjälpa till?
Ja men vet ej exakt än. Sa ok för
mån-ons efter

- Mineralvill/glasull i slutna balar, ^{konstruktion} ^{aktion}

förmår det?.. Hur mycket? 120 vässa
45 installation
220

Klassisk stil

Bejuvrad för kondens

OK om kemik

Åker till Vbg
återbukt någon

- toa = handfat ok att köpa

→ Sittna mitt på WC = fönster
↓ kalle på fjörn? fall? golvvärme?

När dras ek?

→ " installeras värme pump.

fläkt? → de letar en sådan

→ Hur lång tid har de på sig att leta
efter saker? Ser vilka saker
är det inte lönt att de letar
efter...

liteså stort åt sädur behövs?

Takvärmel? mögelavskärning de körd
200 föreslår 100.

Gröndäggning, gräva ner.

Komma isäng svarast, grannen.

→ Gulltar, 1dm från norr-säder
medelmärkta, gräva ner?
Vad för typ av plintar/plattor
takmaterialet 14°

Etervit, papp, plåt på övriga hus
Pågårdar. finns återbukt/
överbukt.

Kille med ladan

- Hur uppstaddad och renskinner måste
räppa boendet midterm 50% vara?

- Ekologiskt, välisolerat, värmeväxlat.

linus möte/achme 1/3

Vännerna bygt energisnålt.

minivärmeväxlare.

Kolla minimi takhöjd 2.1m?

Behövs tillväggen i hallen?

Hylla på båda sidor.

Öppnabent takfönster. finns på blocket

1.1 m, känslan av skydd.

De konsolter, från matbordet.

ok med vidfönster

första intygen 2 nej, svarare på

vid gavel, skymmer siktning + större
glas.



- konstrukt
- Dialog m. Mary (sömmaren)
 - 1- Tidiga intresset.
 - 2- Damsen = stygkig = dröktur
nåtkomning.

Hon var lyhörd för mina idéer om min design och vi hade ett jättebra samarbete under många år.

tackopa, nej pga tjocklek på vägs.

Fasaden ser högt. ok 900 bröstning
Mellan $24^\circ \pm 18^\circ$ typ 16° mellanking.
* Fortfarande inne på brotet tak. Nej
Utsedd et bälte m. 18°

Spontant nej till överhus
rädda för värmen..?

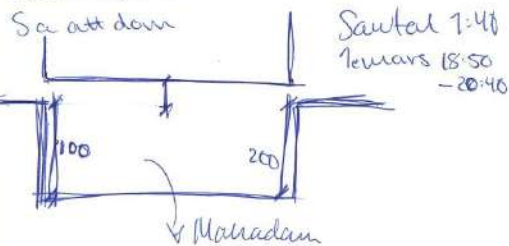

färgglatt fönster i wc

hissande fönster i köket
Ev. öppna lyktor ist för överhus.

Värmen: Pergola, solavskärmning, markis
växtus.

- minst 8 st fönster om 1,2 ^{minst 4 n.} <sub>proportionerligt pga längt
lvs</sub>
- Jön karmar egna
 - Vackert lös i gamla fönster byts fäst.
 - Solavskärm m. pergola/markis/växtus
 - Ok m. 900 bröstning.
 - Fönsterradd tar bort kondens.
- Förvaring i köket, överskap ingår fönstret.
 - Diskmaskinen tar plats.
- Takvinkel
 14° 16° 18°
 - Ej brotet tak, kommer se foltat, ta
bott höjd på taket, dyran, ej takfönster
- Träfönster före aluminium? får ej att revers
 - gamla fönster - kärnme.
 - Hållbart.

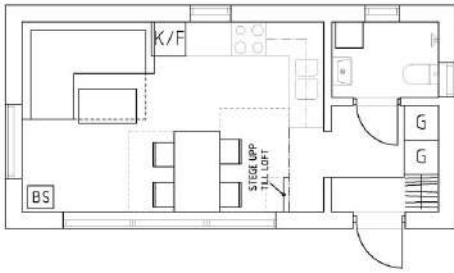

Uppdaterad planlösning efter möte med Linus och Sofia. Köket är ändrat, loftet större, bokhylla bakom stige.

Tisdag 3e mars

Projekteringsmöte med Christian på Tjörn.

Vi kommer inte att hinna få levererat färdigkapat virke från Derome så vi kommer att behöva kapa själva.

Diskussion kring kvalité och hållfasthet/hållbarhet.

Estetik: Ska man ha en återbruksestetik eller en "normalt uttryck"? Vart går gränsen mellan charmigt och skräpigt. Återbruksestetik = Att det syns att det är gamla saker och att det är en blandning av grejer från olika stilar och epoker med olika mycket patina. I vissa fall kan det vara fördelaktigt att man visar att det är återbruk och att man har sämre u-värde på fönster eller har dyra lösningar. Se det som en Catwalk. Det är inte alltid tanken att gemene man ska kunna bära dom kläderna men de är viktiga som inspiration. (Citat Christian i Elins anteckningsbok).

Balansen mellan Återbruk, estetik och kvalité. Ingen poäng att återbruka produkter med dålig kvalité bara för att. Man ska återbruka för att ta vara på kvalitetsprodukter. Om man återbrukar produkter av dålig kvalité och med ful estetik finns risken att återbruk får dåligt rykte och ses som skräpigt och icke energibesparande.

Design for disassembly v.s. att tänka på att det ska stå länge. Det måste vara en balans däremellan då det är naivt att tro att vi inte i framtiden kommer upptäcka brister i den teknik/de material vi bygger med idag. Om 20 år kanske asfaboard är lika illa som asbest katastrofen var.

Stommen går inte att återbruka om det inte är massivtimmer av kärnvirke som man demonterar från gammalt hus, vilket ej hinns med i vår tidsram. Tiden för ett projekt är A och O. Återbrukat virke i stommen går ej då det behöver vara klassat virke för att någon skall våga kvalitetssäkra det. Trä är förnyelsebart och har låg energiåtgång vid produktion vilket gör det rimligt för projektet att köpa nytt. Det är även billigt.

Om vi ska ha plåttak är det viktigt att det är återbrukat. Papptak som vi tänkte först går att få tag i som restvirke från andra byggen, dock går det inte att återbruka i 2a ledet, efter vår användning. Det gäller alla dukmaterial på rulle. Dessutom är det svårare att få ett papptak tätt och svårare att konstruera luftspalten som behövs under ett papptak.

Vi väljer att ha vindsyddande lagret som en board som skruvas fast och därmed kan demonteras om huset rivs eller om vi gör fel. Boarden fungerar även stabiliserande och gör att vi inte behöver ha krysstag. Istället för vindsydd i form av vindplast.

Christian föreslog asfaltboard men då den innehåller en icke förnybar/komposterbar produkt bitumen (ca 12% av vikten enl Gustavs bok) som produceras av olja och avger emissioner så vill vi använda en mer ekologisk produkt. Steico universal är ett bättre alternativ, en träfiberskiva som är vaxad istället för impregnerad. Den är spontad vilket gör att vatten inte tränger/kan rinna av in i skarvarna mellan skivorna.

Som diffusionsbroms kommer vi att ha en papp. Den har en förstärkning av plastnät men det är väldigt lite plast vilket gör mängden i det närmaste försumbar. Då slipper vi fiberdukar av polypropen vilka innehåller övervägande del icke förnybart material. - Siga Majpell ångbroms.

Taket:

Isolering:

Obruten mineralullsförpackning. Återbruka? Kan man blanda olika typer av isolering? En typ av isolering i bjälklag, en annan i väggar? Olika i olika väggar?

Begagnad stenull är bättre än glasull. Stenull är inert - tar inte upp fukt och mögel.

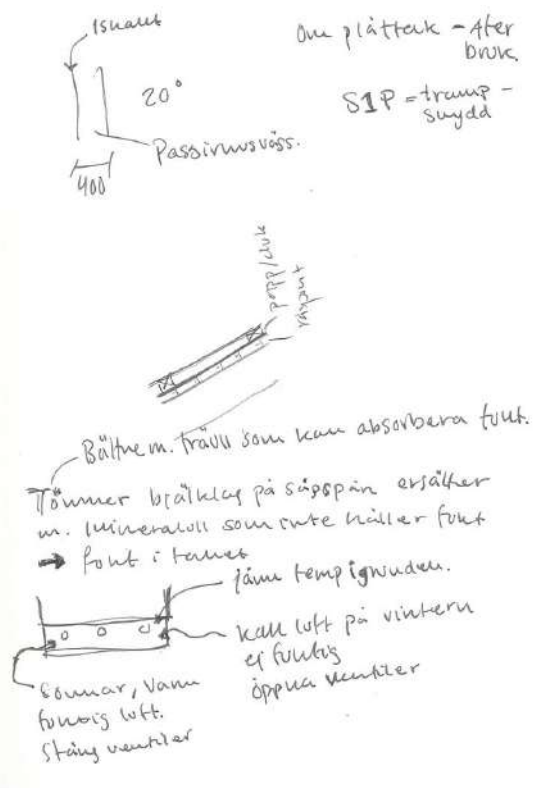
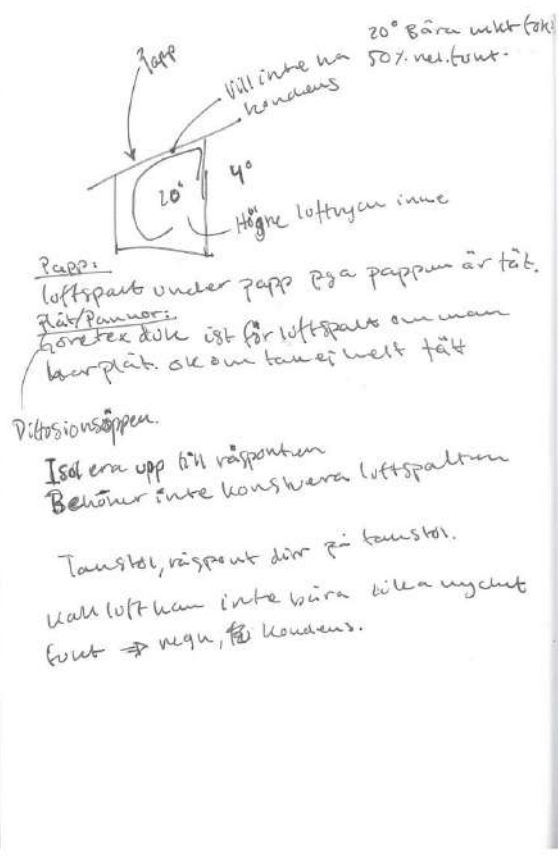



Storsten:

400 mm över ~~hög~~ ^{hög} ~~material~~
 7000 mm över ~~material~~
 Undvikta böjar på storstenen,
 försämrar loftflödet ut.

Tak:

- Lättare att få tält in. Plattor.
-

V:10

- Organisera byggsplatsen
- Väga in punkter.
- Keta plattor
- Leverans ställe
 - Bäcklag
 - Väggar
 - tak (ej nödvändigt)

Isolering i kv. 2 och 3

Prio 1

Skellett.

Asfvalboard

utvärdering energi & transporter. för att bygga
 utvärderingar.

Boant: = stabilitet.

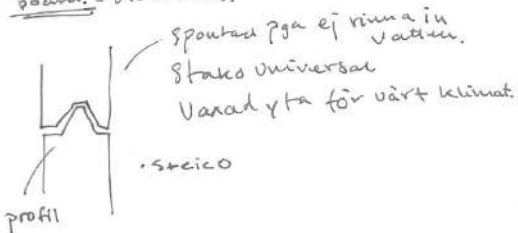

hona suger åt sig fukt
 sniva som bär snivan, putsbärande sniva

att t håll klarar vatten om det
 snellanit får komma ut.

Plaster skapar tätet som riskerar
 att inte låta vset komma ut.

Pappens vater = tät ej återb. bar.
 Tät hos m. ångbroms

OSB + Gips ist för ångbroms.

6 km gamla stora nejla spikar.
 handslagna skallar.

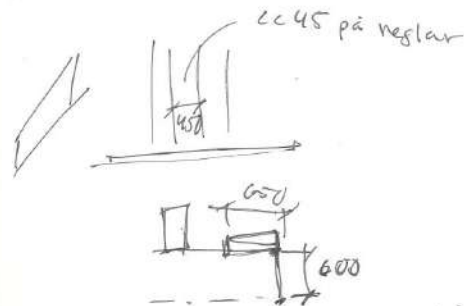

CC30 i badrum pga utskott svaj i
 kanten. vindpapp, fingsmans = 5 ggr tätning
 än vind snydd.

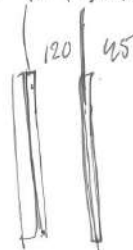

Tak 10 ggr

Prestandadeklaration
 tillverkan
 produktens försv.
 från marken.
 Miljöprodukt
 m. tätet för
 framtida
 renovering.

Ängspänn = tjock plattor 1007. tät

Deklaration:

Daisyweel ← Google

Stansa in/pärm i bjälklag.

Träolit - putsa på. (kerputs)

Golv = återbrukspotential.

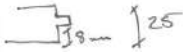

Kalkbruk som fog till golvetegel är asfjermigt. Smulas i. 5dgr/30kvv.

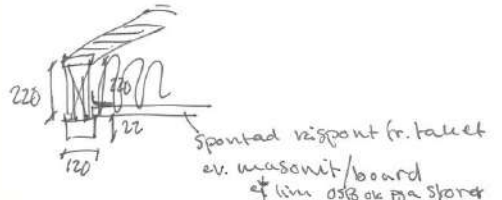
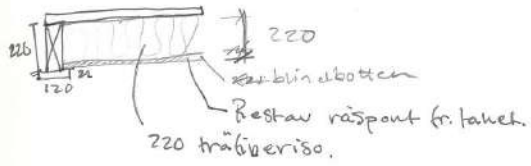

MDF = medium density fiberboard (lim hintra = mindre deformation)

Tjänstboda - stor hall i hintra fr. 1910
mjölkliniekasern.
Enorm spännvidd.

Plast.

Gröna betong kräver platonmatta.

"Catwalk - inte meningen att folk ska ha på sig dom kläderna."

- Christiern (tauke levig återbruk estetisk. Se ut som återbruk eller inte)

Romantiska kopplingen till Konstler.

Estetik. Målenhetgar medlems

Måttforskning

Mannaminne-by vid Högalvsten

Takpannor

fast läktintervall - Järnåker

Pannor längden på taket.

Räspant ~~6000~~ i bjälklag ~~ej~~AMA

Fråga liwo

- Billigare
- Spara material
- Möjelpärant

Glasögon
Handskar

herfygelpannor

Patentat anropist
tak fr. Ladugård.

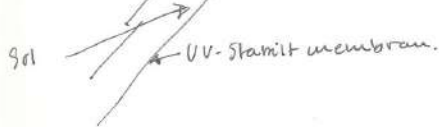

28 x 70 mellan spotarna i fäst
34 x 70 Spiviregel.

Väg in längpass Betongplattor
2 st. Gvs
und ad.

• 150 220, 120, 45

• Golv.

• Rita in innerpanelerna.

Vi borde göra en hierarki av de prioriteringar vi gör.

1. Återbruk med rimlig kvalitet för ändamålet. Ta vara på material med hög kvalitet och hög embodied energy.
2. Eko material som ändå håller över tid och har en bra kvalitet. Det är även viktigt för Linus och Sofia.
3. Om det inte finns något eko material som kan leverera den kvalitet och som kommer att ge huset lång livslängd så får vi använda mindre ekologiskt hållbart material, men helst inte.

Ritningar inför morgondagens byggstart.

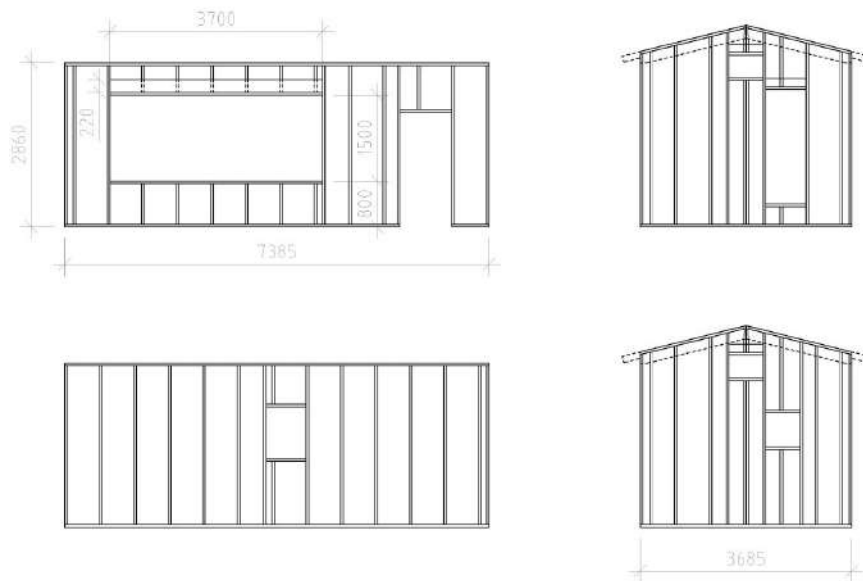

Uppdaterad stomritning efter möte med Christian.

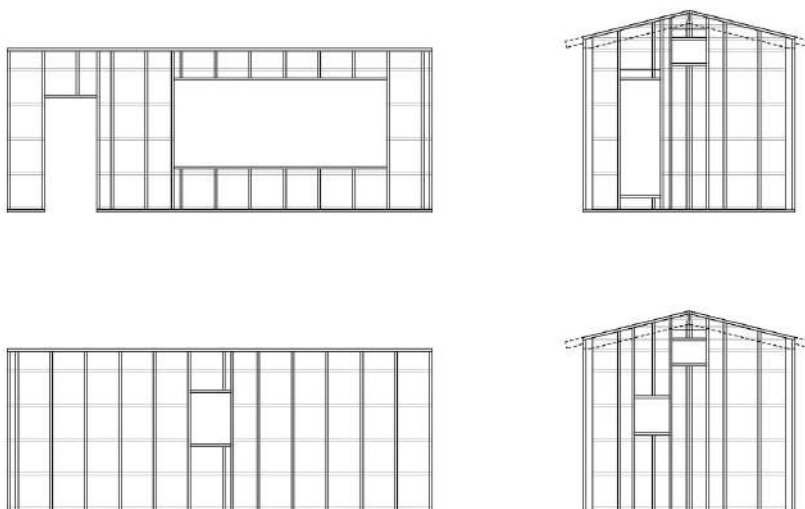

Spikreglar, insida vägg

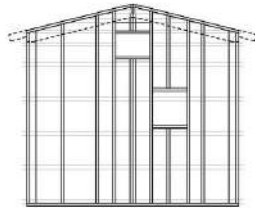
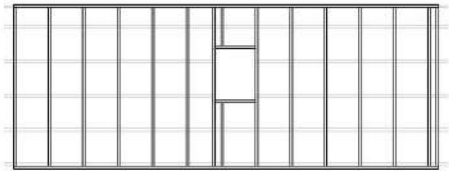
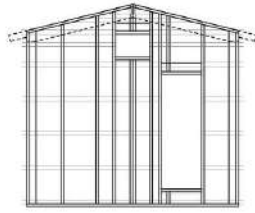
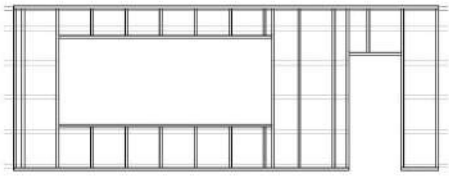

Spikreglar, utsida vägg

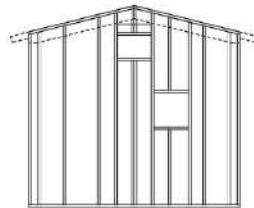
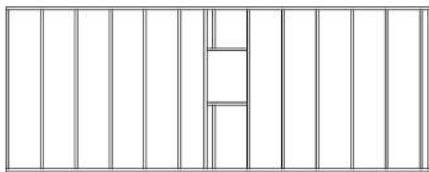
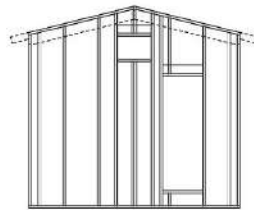
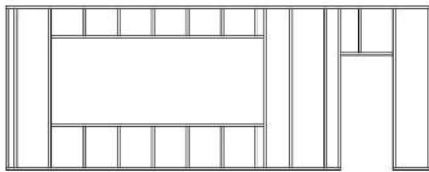

Luftläkt

Onsdag 4/3

Första byggdagen!

Började med att ha genomgång av verktygen på Egnahemsfabriken med Christian. Efter lunch började vi sortera det överblivna virke som Derome lämnat på Egnahemsfabriken.

Beroende på vilka dimensioner man hittar för innertak respektive innerväggar, kan man avgöra om det ska vara horisontell eller vertikal innertakspanel. Om vi inte hittar samma dimensioner till tak och innervägg får taket bli liggande panel. Vill inte ha gipsskivor som beklädnad på insidan - ej återbrukbar.

Reflektioner:

Sortering av virke tar tid i jämförelse med att få allt levererat färdigt av Derome. Däremot var vår process snabbare och underlättades av att allt virke låg i en hög och att vi tidsmässigt var limiterade till den högen istället för att åka och hämta överblivet virke från olika byggföretag och leverantörer.

Tiden för projektet är A och O. Vår snäva tidsram begränsade letandet av saker. Om man har lång tid i ett projekt hinner en större mängd saker flimra förbi på Marketplace och Blocket och chansen att man hittar exakt det man eftersöker är större. Nu hade vi kort tid att bestämma oss för t.ex. fönsterstorlek innan stommen behövde beställas och byggas. Det limiterar mängden fönster till det som kommer upp under de dagarna vi letade.

Tiden har även fått konsekvensen att vi inte känner att vi fått tid att bearbeta, sortera och reflektera över det vi lär oss. Bristen på tid för att dokumentera och sortera i den nya kunskapen har nog varit det som stressat mest.

På grund av vår snäva tidsram samt att vi som arkitekter var initiativtagare till projektet blev gestaltningsprogrammet iterativt då beställaren växlade åsikt om utformning och uttryck under tidens gång. Detta gjorde det svårt att tidigt veta vad för material vi letade efter.

Om kund vet stil = gestaltningsprogram i förväg = hade underlättat letandet av återbrukat material.

Fönstren och taklutningen är viktiga för husets uttryck, vilka varit knäckfrågorna i diskussionen med beställaren angående utformningen.

Tiden har också avgjort att vi kommer att behöva köpa nytt virke till stommen. Hade vi haft mer tid hade vi kunnat efterfråga en större mängd klassat överblivet virke från olika snickare och byggvaruhandlare. Nu är vi begränsade till det som Derome tidigare har lämnat på Egnahemsfabriken samt det som Derome på Tjörn har hos sig.

För att kunna kvalitetssäkra stommen så att en kontrollansvarig kan skriva under behöver virket vara klassat enl. c24. Detta medför att det inte går att använda återbrukat virke till stommen.

Förmålad överbliven fasadpanel klyvs till 22x45 och används som luftläkt. Vill ej använda som fasadmaterial då den är målad med olje/akrylfärg och kunden vill ha slamfärg.

Överblivet 45x70 sågas ner till 34x70 för att användas som spikreglar i fasaden. Kan resten användas som fasadmaterial?

Göra en axo av stommen och markera i färg det som är överblivet/återbrukat material.

Att hitta ett samarbete

Den infrastruktur för självbyggeri som Egnahemsfabriken har byggt upp på Tjörn var helt avgörande för våra chanser att hinna genomföra detta projekt. Kombinationen av deras driv, kontaktnät, erfarenhet, gemenskap och tillgång till byggplats, verktyg, snickare, och materialförråd med återbrukade och överblivna byggdelar. Hjälp med beställning och handledning.

Torsdag 5/3

Midterm seminar info

Skrivit reflektioner, rensat i Thesis Booklet m.m.

Gjort en dummie på Midterm presentation, bestämt att den skall vara fysisk och inte digital för att öva inför open seminar.

Bestämt att vi ska försöka handrita/ha handritad stil på illustrationer för att ge ett levande uttryck på presentationen då hela återbruksprocessen är en väldigt iterativ och levande process.

Använda restvirke, typ spont som bakgrund bakom utställningen.

Göra ett fönster med egna skruvade karmar och ha som "modell" vid utställningen.

Fredag 6/3

Leverans av nytt stomvirke från Derome.

Fortsatt sortering av överblivet material på Egnahemsfabriken.

Måndag 9/3

Fönstret i köket måste placeras för att kunna börja bygga stommen, trots att vi inte har det faktiska fönstret som skall in. Vi ligger lite efter med att leta material.

Köket i huset är ritat efter Linus föräldrars kök som de skall byta ut vid renovering.

Linus och Sofia letar däremot efter ett annat kök ifall att det skulle dra ut på tiden med föräldrarnas renovering. De vill hellre ha en mindre soffa om de kan få ett bättre kök. I senaste skissen är fönstret placerat mellan spisen och kylskåpet på norrsidan. Om man flyttar kylskåpet till under stegen till loftet blir vi mer flexibla med vart fönstret kan placeras beroende på vad för köksmoduler som det i slutändan blir. Fönstret behöver inte vara precis mitt över bänken bredvid spisen, vilket medför att spisen kan vara

“nollpunkt” för fönstret och då är bredden på fönstret mycket mer flexibel eftersom vi inte hittat fönstret än. Dessutom kan man använda smalare bitar än 800 + 600 (bänkens bredd bredvid spisen, minimimått för att ett fönster i lagom storlek skall få plats + kylens bredd).

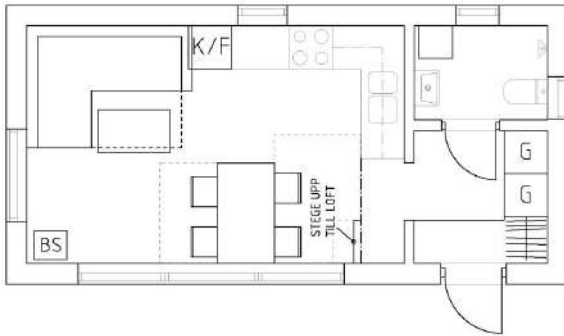

Planlösning, innan ändring

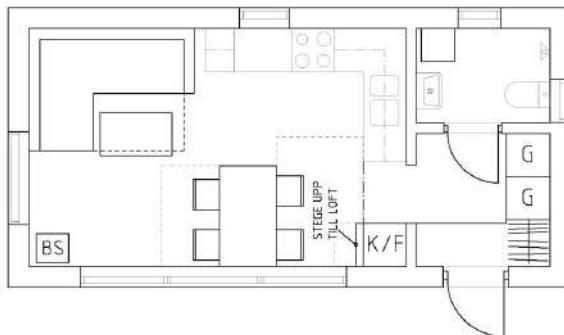

Föreslagen planlösning - längre bänkyta, mer flexibelt fönster i kök

Handledning måndag 9/3

Vi bör lägga till en part 3 som jämför processerna i part 1 och 2 och de olika skalorna. Reflekterar och lyfter självbyggeriskalan till nästa skala. Det är här vi lägger part 1 och 2 parallellt och det är här de får informera varandra.
Bullet Point till midterm om vad vi planerar att skriva om i part 3.

Toolbox blir referensprojekt

Svarlamoen, Upcycle studios, resource rows kanske ska tillhöra part 3 medan part 1 fokuserar på branschen och på designprocessen med referens till Superuse studios och förhoppningsvis Lendagers som vi får höra under Arkitekturgalan.

Reflektera över hur bra man mår av att vara ute i friska luften och röra på sig som när vi bygger huset. Idag är arkitekturyrket uppbyggt kring datorer och möten inomhus. Kan arkitektens roll påverkas/förändras och designprocessen förändras genom att vi

arbetar mer fysiskt. Genom att vara mer ute på byggen och förstå vad som händer där och få en bredare erfarenhet kan arkitektens kunskap breddas och status höjas.

Reflektioner utklippta ur midterm booklet

För andra sammanhang

Loggboken fångar upp vår process så att vi sedan kan dra ut element till rapporten. vad som kan ha varit viktigt tidigt är inte så lätt att komma ihåg senare.

Viktiga lärdomar och viktiga vändpunkter. Man vet inte alltid det förrän lite senare.

Förstå de olika rumsliga förutsättningarna för ett attefallshus

Vad är det vi vill säga med materialet?

Cost

David påpekade att detta med kostnad kanske inte går att generalisera över alla material demolition utan beror på kvaliteten i materialet. Det är ju skillnad på ett ikeakök och ett från ballingslöv i vad det har för värde och kvalite. Det är kanske som att jämföra äpplen och päron om man jämför kostnaden för bearbetning av återbrukad betong med kostnaden för ett glasparti som bara behöver flyttas...

Diskussion med Ida och Sara om kostnader och politik

One of the problems the reuse process is facing is the high price on labour and the low price on virgin materials. Due to the industrialisation we are nowadays fitters of new machine made products instead of being craftsmen of materials. This makes the refurbishment of reused materials expensive. In his TED talk, Cecaré Peeren (2015) argues that we are not only wasting materials and resources, we are also wasting people who are now unemployed. By upcycling and refurbishing materials, the potential labour would increase and benefit the society. He proposed a higher tax on virgin materials and less tax on labour to mend this problem. Though regulating the market with taxes might have an affect but it can also backlash in unknown ways. By putting tax on virgin materials might make the already high rents in new built residential go up even more. Then one solution might be to lower the land price, but that is also one of the incomes for the municipality which supports our public sector. Then the municipality might only rent out the land to the developer, but who would like to build and invest in a building put on ground that they don't own, the risk calculation is unstable. The solution must be to make it expensive to get rid of waste and put it in landfills. A system where it is cheaper to leave waste the higher up in the waste ladder it can be used. (ingen källa på detta, bara diskussion)

Tisdag 10/3

Arkitekturgalan.

Kväll:

Uppdaterade, måttsatta ritningar inför bygget imorgon. Underlag för studiebesök på torsdag.

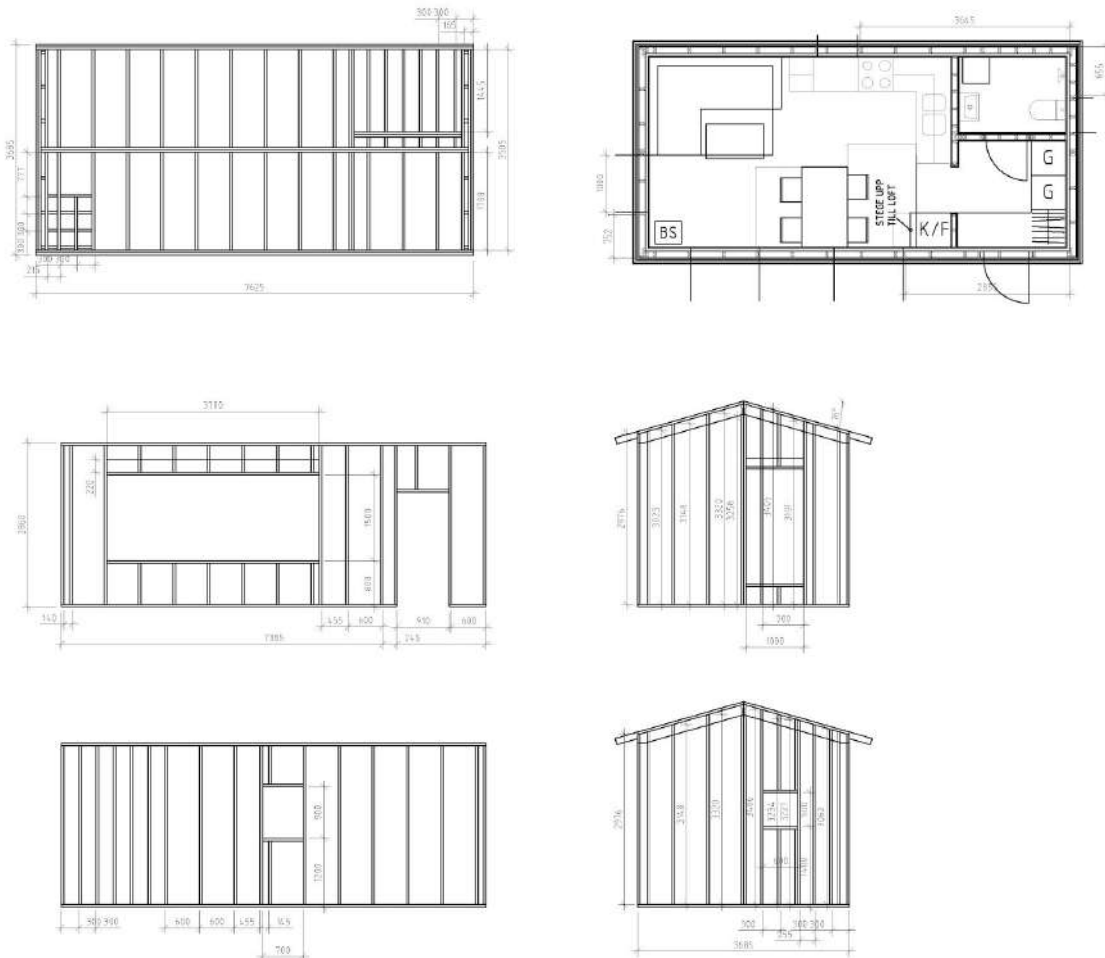

Onsdag 11/3

Elin jobbade tillsammans med John på första halvan av bjälklaget. Miriam satt med Christian och gjorde ritningar med måttkedjor inför morgondagens studiebesök. Vi kommer få hjälp av fyra studenter hela dagen med att bygga. Måste förbereda oss för att kunna ge dem bra uppgifter - sätta ihop stommen.

Vi hade tur att det behövde planeras inför morgondagen, så att Miriam kunde bidra till bygget trots den skadade ryggen. Dessutom behövde ritningen uppdateras lite efter mindre justeringar.

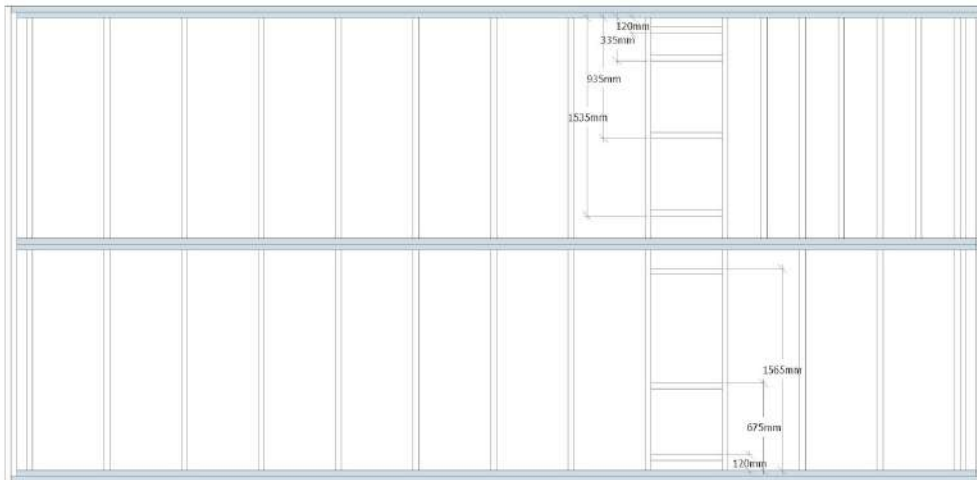

Bjälklag - måttsatt

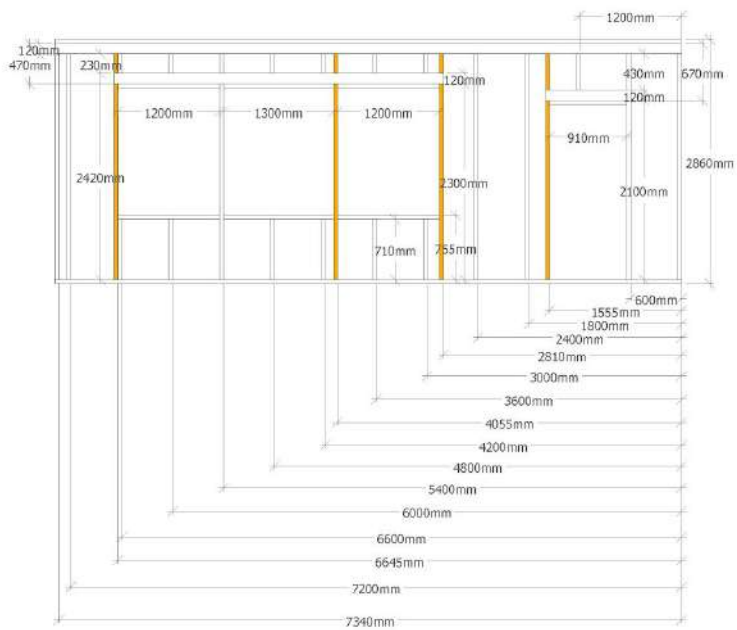

Vägg 1 - mot söder

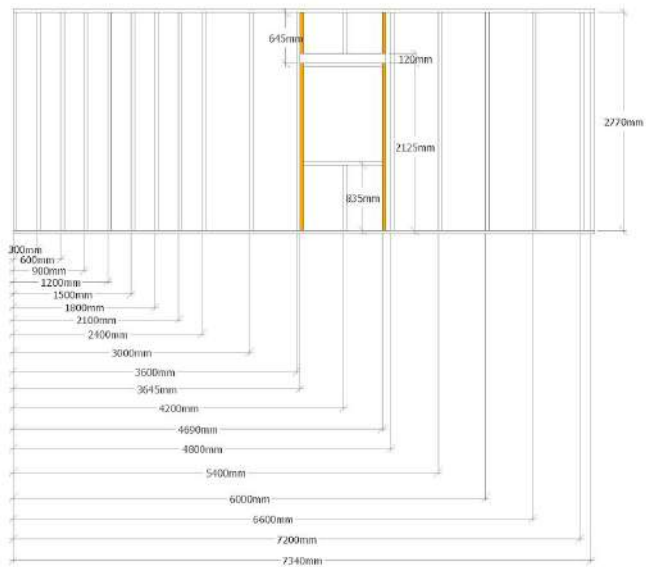

Vägg 2 - mot norr

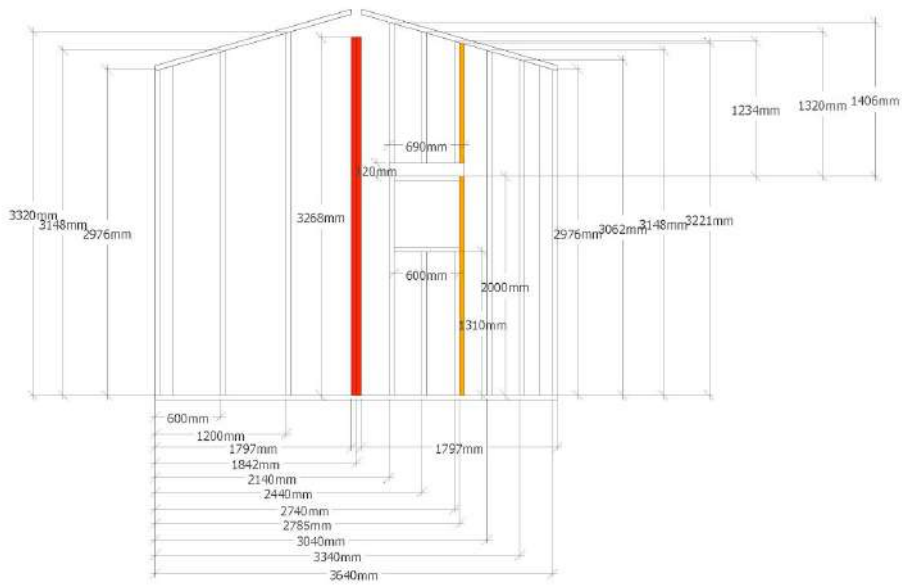

Vägg 3 - mot öster

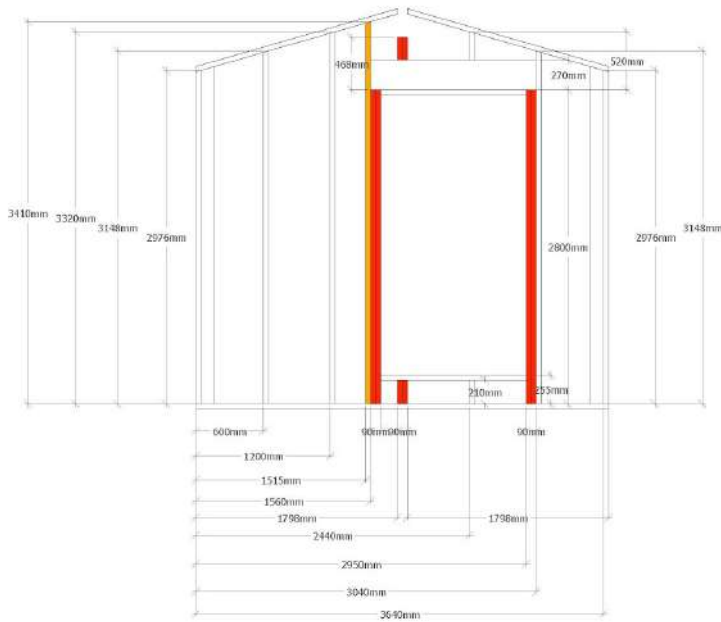

Vägg 4 - mot väster

*Röda reglar - pelare, 90x90 mm
 Orangea reglar - reglar som frångår c/c 600.

Tankar om dagen:

- Att arbeta in sig med verktyg och folk tar lite tid.
- Olika ansvarsområden kan vara bra men hade vi haft mer tid hade vi kunnat gå igenom alla olika moment tillsammans.
- Handledning på ritningar hade varit bättre att ha mycket tidigare, innan bygget startas
- Svårt att hitta stora, begagnade fönster
- 2 luft 10x12 i köket
- Förlorar byggtid pga att ritningarna inte är klara, pga sena med beställare. Allt har förskjutits. Istället för att designprocess, inventering och bygge har en egen del av projektet överlappas allt samtidigt. Blir en konsekvens för användning av överblivet virke - svårt att ha tid att leta material.

1 Ret proj. analysera.

2 Byggsdelar avg i vårt prop.

- Trästomme/timmer/KLT/massiv.
 - Fönster begr. pga höjd
 - Kalk
 - Tekmaterial
- re-nise + fasad + fönster
re-stora bygg.

Glöm ej att hänvisa historiskt!

3 Vad för typologi?

- Enklare med bostäder där man kan fönstersätta efter funktion.

4 Hur förhåller man sig till kulturans & historisk förankring?

Pastisk?

Estetiska & byggtekniska kvalitéer tas vidare/bevaras.

Estetik etnewd.

Skönhet är en funktion som värde sättes mer för.

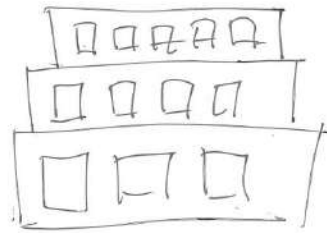

Delar in fasaden i partier/per våning

Klassisistisk illusion.

Pagens trend är stora systematiska grid i fasaden.

Genom återbruk kan man ta fram livfulla arkitektoniska kvalitéer. Variation skapar liv i fasaden.

Lätt att hitta fönster i Winacade stil & mått

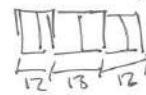

Våra fönster, så länge de är lika höga.

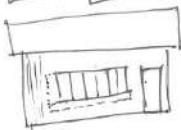
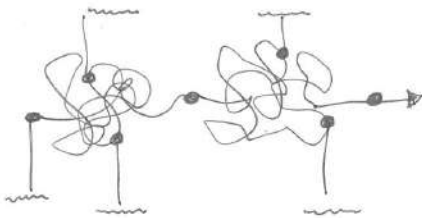

Final fasad m. marginaler för vad vi ville ha när vi hade bestämt vad vi letade efter...



Johns fönster



Måjlige fönstersättningsprinciper m. denna metoden.

☺ → ☹ = ful!



Arx/sprängsviss

färglägg det överlappande. Berätta om tidsuspensen. ta tag i överl.

Bilder på skador vi sorterat bort fr. överlännet vinn.

Visa att de kan vara solbrända.

Hitta "handsfritypsnitt" som vi gillar

3 bifoga grafisk profil som bilaga till rapporten.

Skisser från funderingar kring ihopsättning av bjälklag - vill kunna ha så lite spill som möjligt. Måste tänka på vilka dimensioner virket kommer i (3.0, 3.6, 4.2, ...)

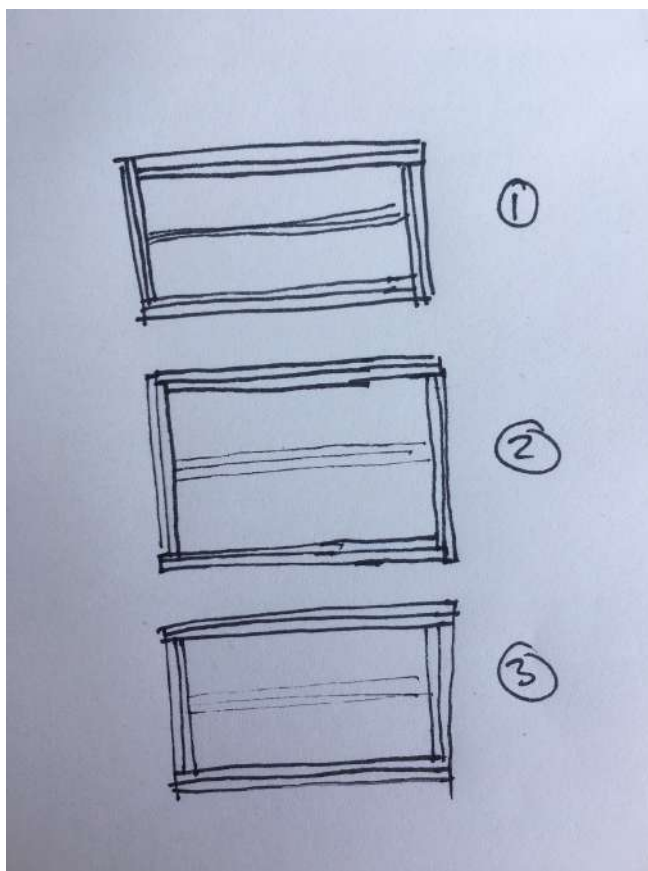
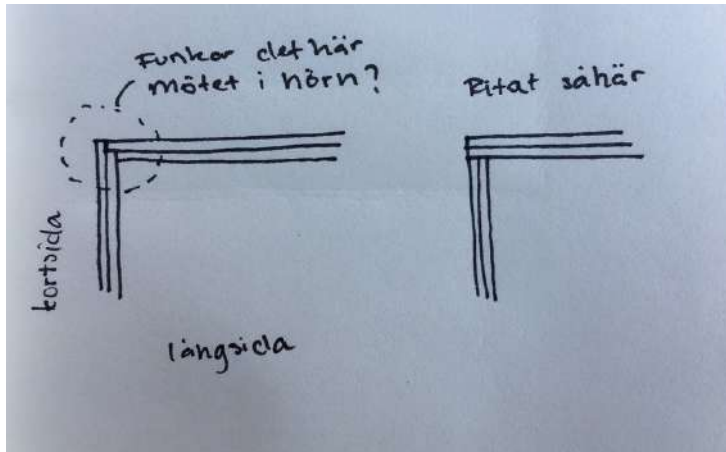

Torsdag 12/3

Studiebesök från John H's klass, Chalmers, blev inställd pga väder och sjukdom. Vi hade tillgång till Raed, Christian och John hela dagen. Vi byggde klart hela bjälklaget. Det gick väldigt mycket snabbare när man var fler och med kunniga personer. Lätt att man missar att göra små moment, som att sätta fast brädor under golvreglarna för att kunna fästa trossbotten.

Dessa är återbrukade, klivna fasadpanelbrädor som vi valde att skruva istället för att spika.

Man kommer aldrig lyfta bjälklaget/gå under det vid eventuellt nedmontage, utan man kommer sparka/slå igenom det. Om man har skruvat brädorna i bjälklaget är risken stor att brädorna går sönder när man slår, alternativt att man tar en såg och kapar brädorna. Om det är spikat kommer brädorna glida ur lättare och möjliggöra borttagning av spikarna efter att de lossnat från bjälklaget.

Fredag 13/3

Elin påbörjade utsågning av väggreglar medan Miriam var på Ryggakuten på förmiddagen. Miriam räknade ut ungefärlig mängd isolering för att Linus och Sofia ska kunna leta efter begagnad isolering. Skickade iväg måttsatt ritning till dem för att kunna se dimensioner på kök och badrum - hitta begagnat. Skickades på kvällen.

Färdigställde vägg 1.

Coronadiskussion - pratade med Tinna efter deras styrelsemöte. De vill antingen att vi bor permanent på Tjörn under byggtiden, eller har tillgång till bil och inte åker kollektivtrafik - allt för att inte öka smittspridningen. Vi tvingades ta ställning till detta och försöka hitta bil.

Miriam ska fråga hennes pappa om vi kan låna en bil. John har erbjudit oss sovplats i hans hus.

Kritiskt för vårt bygge. Vi måste kunna fortsätta bygga trots epidemin. Svårt om vi inte kan låna bil, eller att någon av oss blir sjuk. Då kommer det inte gå att genomföra det praktiska experimentet. Får alternativt sitta i karantän på Tjörn. Det funkar men lite tråkigt då allt socialt liv försvinner.

Måndag 16/3

Köksfönstrets placering baserades på tidigare köksutformning som under möten med beställare har ändrats. Från början var tanken att överkant skulle linjera med överskåp och att underkanten var 900 mm bröstning för att hamna ovanför köksbänken. Dessa mått blev intervallet att hålla sig mellan. På senare möte den 2 e mars ändrades köket för att ha överskåp till att ha öppna hyllor. Dels för att bidra med möjlighet till ett större fönster men även för att kunna vara mer flexibla med bredden på fönstret då beställarna önskade ett öppnare uttryck och tyckte att det var fint med öppna hyllor. Något som fallit bort i vår tanke när överskåp ändrades till friare hyllor var att det finns ett tydligare

behov av att överkant fönster linjerar med övriga fönster i rummet. Det var inte ett lika tydligt estetiskt krav när fönstret var placerat mellan överskåpen.

Att köksfönstrets överkant var 200mm under de övriga fönstren i rummet slog oss när vi gjorde regelstommen runt fönstret. Det gick dock relativt lätt att flytta upp köksfönstret 200 mm för att tangera med överkant på det stora fönsterpartiet på södersidan. Tur att vi kom på det i sista stund! Det hade gått att åtgärda senare men med högre arbetsinsats.

Bild på hur vi flyttat fönstret och lagat hålen

Vi hade en diskussion om isolering med Christian. Linus hade hittat 10 obrutna balar mineralull som blivit över vid ett bygge. Då mineralull är energikrävande att producera vill man gärna återanvända det, men det går inte att blanda olika sorters isolering i samma hus eftersom "systemet" med ångbroms/ångspärr m.m. är olika beroende på vad man har för isolering. Om man inte hittar mineralull till hela huset (väggar, golv, tak) behöver vi köpa ny mineralull vilket inte alls skulle vara ekologiskt försvarbart. Vi skulle istället vilja isolera med träfiber som är en produkt skapad av rester från sågverk, vars "system" bygger på att materialet andas och kan bära fukt och släppa ifrån sig det vid senare tillfälle. Detta system är mycket mer ekologiskt och kräver inte lika fossila omkringliggande material. Dock inget återbrukat material. Frågan är hur långt man ska sträcka sig för att återbruka så mycket som möjligt? Genom att använda ny träfiberisolering kan vi bygga ett på lång sikt kvalitativt och eko hus istället för att dämpa påverkan på miljön från de utsläpp som de 10 balarna mineralull har orsakat och därmed bygga in ett icke ekologiskt material. I part 1 av booklet är kontentan att man alltid ska välja kvalitet och bra material i främsta rummet. Man ska inte bygga in svagheter. Vi ska fundera på detta till imorgon, men det lutar åt träfiber pga det bättre "systemet" av omkringliggande material i eko.

Tisdag 17/3

Kvalet med val av isolering löste sig nästan av sig självt då vi fick en leverans av 8 balar med överbliven träfiberisolering 145mm från bygget Christian och Raed håller på med nu (Hultet). Vi tog beslut att använda träfibern till bjälklaget på 220 mm och blåsa in resten (75 mm träfiber). Detta gör att den isolering vi behöver köpa till blir ny träfiber vilket gör att vi kan använda.

Vi tog en till vända på det stora gavelfönstret och insåg att det blir alldeles för stort. Vi fick avbryta bygget av gavlarna och försöka hitta fönster till båda gavlarna, ett långsmalt i väst och ett lite mindre till toaletten. Gick in i ladan på Egnahemsfabriken och kollade igenom alla fönster en gång till, men utan framgång.

Gick in på Marketplace och Blocket.se och kollade igenom alla annonser en gång till, även de utanför vårt område. Vi lyckades reservera ett fönster till västergaveln med måtten 700x1900, med bröstning på 400mm. Detta finns i Gislaved. Vi hittade även ett öppningsbart fönster till toaletten med måtten 500x800. Vi väntar fortfarande på återkoppling.

Takmaterialet har vi tänkt ska vara plåt, men utbudet på andrahandsmarknaden för takplåt är inte så stor. Vi hittade ett plegel-tak (taktegelpannor av plåt) från Plannja, överblivet material, på ca 40 kvm. Detta finns i Sävsjö. Fortfarande inte fått något svar kring storlek och pris.

Vi frågade Linus om han har möjlighet att hämta det stora fönstret och eventuellt samtidigt hämta takplåten, om vi kan köpa det. Han har möjlighet till detta nästa vecka. Ritade in de nya fönstrena i gavelritningarna och påbörjade bygget av gavlarna.

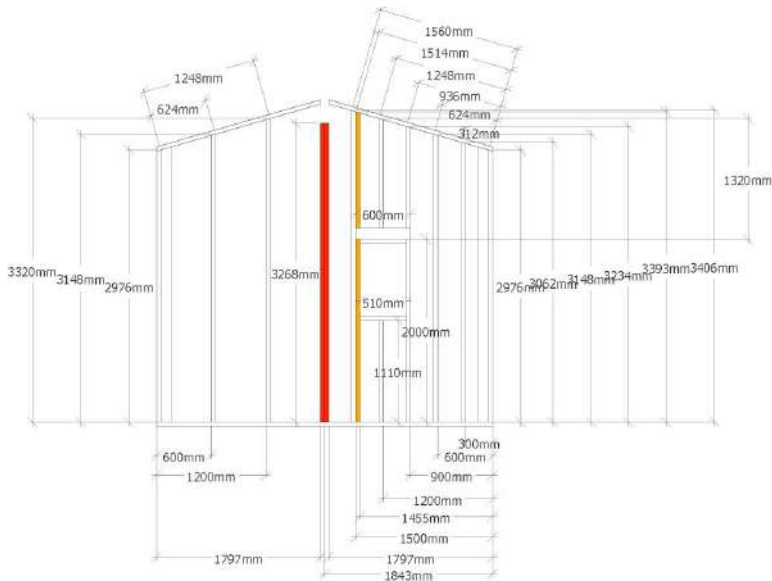

Uppdaterad ritning - estimerad fönsterstorlek (500x800 mm).

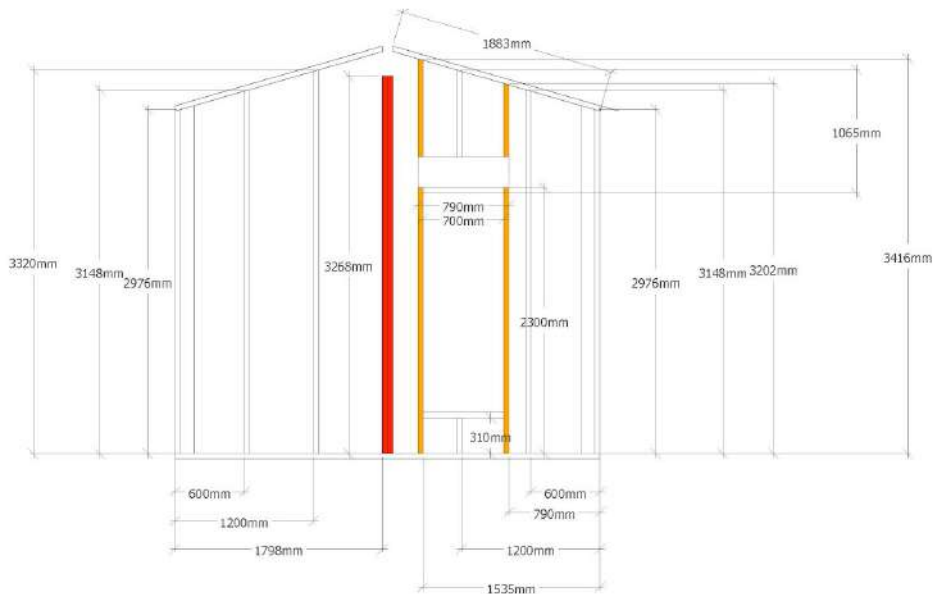

Uppdaterad ritning - fönster, 700x1900 mm.

Hann nästan klart med allt. Valde att inte sätta fast över- & underliggare till toalett-fönstret då vi inte har köpt det ännu. Hammarbanden ska sågas ut och sättas fast + fyra reglar som sitter i hörnen.

Att göra imorgon eftermiddag, efter inlämning:

- gå igenom beställning till Derome (isolering, vindskiva, ångbroms...)
- beräkna spikreglar, kontrollera att vi har allt som behövs
- typ av fasadpanel? Om vi ska ha lockläkt är det bra att ha två dimensioner på brädorna - fint med 120 och 145 mm.
- luftläkt kommer vi från från Hultet, överblivet material
- bestämma vilken typ av tak vi ska ha
- kolla upp om det är möjligt att ha gavelfönster på sovloftet - får det plats? (önskemål från Sofia och Linus)

Onsdag 18/3

Mejl från Linus och Sofia.

De är vill hemskt gärna ha ett fönster uppe på loftet. Ritade upp gavelfönster snabbt - det blir trångt. Ringde Christian för att rådfråga om det är möjligt - "man kan bygga vad som helst, man måste bara tänka på det". Vi ska kolla upp vilka dimensioner avlastningen behöver ha över fönstret för att ta upp takets laster. Går det att få ner under 90x270?

Linus har hittat ett fönster som är 900x2000. Närmare men helt nytt. Vi tycker att de ska köpa det i Gislaved - återbruk prio!

Svårt att hitta plåttak, Linus föreslår att köpa nytt pga att det är billigt, men vi tänker nej! Om det ska vara plåttak måste det vara återbruk. Inte miljövänligt - stor energiåtgång vid tillverkning.

Torsdag 19/3

Vi gjorde klart hammarband och satte delvis fast dem på gavlarna.

Beräkningar och diskussioner med Christian angående hur vi avlastar loftets gavelfönster, då Linus och Sofia väldigt gärna vill ha det. Ordnar med beställning från derome.

Måndag 23/3

Färdigställde västra gaveln, väntar med den östra. Har beställt pelare och avlastningsbalk. Satte ut betongplattor ute för att kunna flytta ut bygget imorgon.

Vi upptäcker att vinkeln mellan ytterdörren och öppningen från hallen till stora rummet gör att det inte går att få in möbler i huset, speciellt inte en soffa. Vi kollar måtten på paketen på Ikea och det är stor risk att det inte går att få in, det vet vi inte förrän vi kan testa i verkligheten och då är det försent... Dessutom skulle vi då begränsa framtida möblering till nyinköpta produkter som är isärmonterade, vilket inte är bra. Om deras

säng på 160cm bredd är delad i två 80cm sängar går de in genom fönstret men soffan är fortfarande det stora problemet. Klurar på detta länge.

Föreslår för Linus (beställaren) att flytta dörren till östra gaveln. Då får vi en rak inlastning av möbler och dörren får plats inom ramen för avlasningen av gavelfönstret ovan. Det blir fortfarande en bra hall med samma möjlighet till förvaring.

Om flytt av ytterdörr till gaveln vill Linus ha en altandörr på framsidan istället för ett av de tre fönstren. De vill absolut ha möjlighet att gå ut på framsidan medan vi inte tycker att avståndet mellan ytterdörren på södra sidan och på östra sidan är märkbar i detta lilla hus.

De flesta altandörrar vi hittar snabbt under undersökningen är 2100 mm höga vilket gör att bröstningen på de övriga fönstren bör sänkas till 600 mm för att liva med altandörren i överkant. Låg bröstning var Linus och Sofia starkt emot vid senaste fönsterdiskussionen för ca 3 veckor sedan. De ville då ha 1100 mm bröstning men vi landade tillslut på 800-900 efter att ha diskuterat med Archicad modellen som visualiserande hjälpmedel.

En altandörr skulle även göra insidan av södra väggen mer begränsad för möblering, vilket är synd i en så liten bostad. Dessutom måste vi sänka de två andra fönstren på västra och norra väggen för att invändigt liva i överkant med de flyttade södra fönstren. Detta innebär förändringar i reglarna på ALLA gavlar som vi nyss färdigställt... Jobbigt och tidskrävande!

Man skulle kunna ha en 200 mm hög bröstning på altandörren, det funkar men är inte helt klockrent...

Ett alternativ är att sätta en altandörr istället för det västra, långsmala fönstret. Det är ett förslag Miriam kom på tidigare under processen när vi hade svårt att hitta ett högt och smalt fönster för västgaveln. Dock har ett fönster 700x1900 hittats och inhandlats. Det går att sälja men det vore synd. Då skulle man ha kvar entrén på södra sidan men kunna lasta in möbler genom altandörren på den västra. Dock snyggast med 700x1900 fönstret.

Vi skickar flera förslag på hur det kan se ut visualiserat i archicad till Linus och Sofia och skall höras imorgon igen när de diskuterat.

Christian håller med oss om att det skulle bli snyggast att behålla de södra fönstren som de är men flytta ytterdörren till östra gaveln. Han berättar att det finns en altandörr som är 2300 mm hög på Egnahemsfabriken som i så fall skulle liva med överkant på nuvarande söderfönster. Vi ska kolla hur den ser ut imorgon och se vad Linus och Sofia har kommit fram till.

Tisdag 24/3

Började flytta ut bygget till projektbyggarytorna. Linus och Sofia kom lagom till vi skulle bära ut bjälklaget - väldigt tungt! De hade med sig resterande fönster, lite virke samt plåttak från en gammal lada. Vi var tvungna att väga in bjälklaget på nytt väl på plats och justera höjden lite. Vi upptäckte att bjälklaget var för långt med 90 cm (2x45 reglar). Fick justera detta på plats. Vi fick även upp den ena långsidan, mot norr, innan dagen var slut. Sofias mamma och man kom förbi med mat och fika vid dagens slut - väldigt trevligt!

Onsdag 25/3

Christian var på plats och hjälpte oss. Reste den andra långsidan och den västra gaveln. Vi fick även leverans av en ny limträbalk - slipper skarva över mittpelaren.

Torsdag 26/3

Satt med presentation och inlämning av opponering och presentation från 7-10. Började bygga först 11:30. Byggde klart den östra gaveln och reste den, helt själva.

Lördag 28/3

Att hitta fönster till detta projekt, lite skala, visade sig vara svårt när man använder principen "designa först, hitta sen".

Att ta upp det till större skala blir genast en större utmaning, både att hitta rätt antal fönster men också typen av fönster man vill ha. Andrahandsmarknaden är begränsad och mycket av det som finns är antingen av sämre kvalitet (kräver fönsterreovering) eller av "fel" material och stil.

I en större skala blir det därför viktigare att samla på sig material först och designa efter detta, för att underlätta återbruksprocessen och säkerställa ett sammanhållet uttryck. Sen finns det olika sätt man kan ta sig an fönster och hur man kan kombinera ihop dem med varandra, men det blir desto lättare om man har ett lager med material. Återbruk kräver tid och bra lagerhållning.

Dessutom behöver samarbetet med "rivnings-/reoveringskonsulter" bli bättre så att kontoren/projektledaren kan få material från dessa, som ändå kanske skulle slängts trots deras goda kvalitet.

Det var även svårt att hitta många a

Måndag 30/3

Möte med Joakim från Hunton om isolering och boards (vindskiva) som de levererar. Han påstår att man kan återbruka isolering som tidigare suttit i annat hus, vilket Christian tidigare sagt inte var möjligt på grund av att det finns risk för fukr och mögelsporer i gammal isolering. Joakim menar på att om man kollar på träet i väggen och ser att det inte är fuktskadat och att isoleringen känns torr när man öppnar väggen så finns ingen risk för sporer eller fuk. Dock finns fortfarande risk för lukt och då isolering kan falla ihop av egentygden så har den troligtvis sämre isoleringsvärde. Om en skiva varit 120 mm tjock när man monterade in den så är den med största sannolikhet inte 120 när man tar ut den. Då är hålrummen i isoleringen sammanpressade och om man fyller på med isolering utanpå för att fylla upp så pressar man samman den ytterligare, vilket medför ännu sämre isoleringsförmåga.

Sågade ut avlastningsbalk och nockbalk, fick hjälp av Raed att såga vinkeln på nockbalken.

Miriam fick hjälp av Isak att loda den östra gaveln, mycket var snett då den byggdes på dåligt underlag direkt på marken (marken var sne). Elin tillverkade en mall för taksparrarna och sågade ut de rätta längderna för resterande 15.

Dessutom menar Joakim att man kan blanda olika typer av isolering i samma vägg så länge de ligger i olika fack. Detta på grund av att man kan använda deras ångbroms till både mineralull och till träfiber isolering. Vi hade tidigare förstått det som att det inte var möjligt att blanda då de olika isoleringarna tillhörde olika "system". Dock ska man inte blanda olika typer av isolering i taket och i golvet. (Minns inte varför, ska maila om det)

På grund av tidsbrist har vi inte dubbelkollat dessa olika påståenden vilket fått konsekvensen att vi inte har planerat för återbrukad isolering i detta projekt. Det kanske fortfarande finns tid att ändra på detta...



Tisdag 31/3

Reflektion om återbruk av trä.
Vår bild av återbruk var från b

örjan att en strävan efter 100% återbruk var det bästa. Något idealistisk kanske. Efter att ha byggt en del av huset inser vi hur värdefullt det är för tiden och tålmodet att virket är någorlunda rakt och beter sig bra, dvs. inte kröker sig eller spricker. Dessutom tar det tid att för hand kvalitetssäkra och dra ut spikar. Vi känner att det endast skulle vara försvarbart tidsmässigt om det återbrukade var restvirke (nyskick) eller kärnvirke från äldre timmerhus av bra kvalité. Att rensa gammalt virke på spik och riskera att köra sönder sågklingor på grund av gömd spik känns krångligt och onödigt i förhållande till den energimängd man sparar. I samma hus som man vill återanvända virke kommer man högst troligt även att ha en kamin där man vill elda densamma. Ang. timmer, referera till metod föreslagen i Taleens rapport.

Sågade ut taksparrar.

Fick hjälp av Isak och Ramon att bygga en "brygga" för att kunna fästa taksparrarna i nockbalken. Väldigt skönt att vara fyra personer för detta moment.

Onsdag 1/4

Vi fick hjälp av Raed att räta upp gavlarna. Det visade sig att båda hade blivit sneda upptill -

måttet på bredden stämde inte med syllens mått. Allt som behövdes var att lossa på hammarbandet från reglarna och föra in en skruv snett för att få väggen rak - ett supertips från Raed. Det märks att han har jobbat som snickare i 25 år, han sitter på mycket tips och tricks. Vi fick fast alla taksparrar och sågade ut "brädor" och satte dem mellan taksparrarna. Målet för dagen var att hinna sätta upp all råspont och takduk, men så långt hann vi inte. Mycket på grund av att vi hittade fel i väggarna som påverkade taket. Viktigt att vara noggrann vid lodning av väggar, annars blir taket snett.

Vi hann nästan klart att lägga råspont på ena halvan av taket. Kämpade i en timma att försöka lägga på presenning i världens blåst. Fick hjälp av Anna.

Torsdag 2/4

Vi har insett att det är bäst att designa först och leta efter material sen, för att ha ett humm vad man är ute efter. Det är svårt att leta efter material när man inte har något att leta efter/vet vad man ska leta efter.

Det går fortfarande att hitta material först och designa sen, men då är det viktigt att man kan lagerföra sitt material och att det inte gör något ifall det blir material över. Egnahemsfabriken är en perfekt plats för att kunna designa efter vilket material man har - de gott har lagerplats och byggytor för att kunna bygga på plats.

Det är lätt att kritisera projekt som försöker göra något, om de inte är transparenta och öppna med vad som inte blev som de tänkt. Viktigast är reflektionen över vad man lärt sig och vad som man hade gjort annorlunda i nästa projekt. Man ska inte försöka släta över det som inte blev "rätt".

Måndag 6/4

Färdigställde första halvan av taket med råspont. Påbörjade andra halvan av taket och hann klart, förutom uppe vid nocken, tills Christian kom vid lunch. Fick hjälp av Ramon idag, det gick undan att lägga på råspont!

Christian kom och kollade på arbetet, kom fram till att vi behövde ta upp en rad med råspont för att kunna såga av nockbalken (vilket vi hade glömt bort) och han upptäckte även att nockbalken flög i luften och inte landade på avlastningsbalken på gaveln. Stort frågetecken i våra huvuden!

Efter lunch försökte vi klura ut vad som gått snett, varför nockbalken flög. Det visade sig att nockbalken låg helt rakt, alltså inte den som var sne, utan gaveln hängde ner/hade en lägre punkt i mitten än vad resterande byggnad hade. Kan berott på att stenarna under inte låg under gaveln utan en bit in under huset = inte tillräckligt med stöd. Det tog sin lilla tid att fixa till detta "fel" men tillslut fick vi rätat upp gaveln.

Nockbalken sågades av och utmätning för råsponten till nocken gjordes. Fick använda en typ av cirkelsåg som gjorde det väldigt enkelt att såga rakt. Sågade även av all råspont som stack ut för långt på sidorna.

Vi hade tänkt hinna lägga på takduk, men Raed och Christian var tvungna att sticka och det började dessutom blåsa ganska mycket efter lunch. Så det var svårt att klara av att göra detta på tre personer, som dessutom är okunniga. Vi bestämde oss för att komma tillbaka imorgon och lägga på takduken tillsammans med Christian.

Fick även denna gång kämpa med att få på presenningen, men det gick lite snabbare iaf.

Ännu en gång ett fel har uppenbarat sig och det faktiskt går att lösa med lite fitness. Viktigt att man hittar orsaken till felet.

Tisdag 7/4

Bygget startade idag tidigt på morgonen, kl 7. Åkte från Göteborg kl 6...

Christian hjälpte oss att såga ut trekantslister till gavlarna. Även Robin kom och hjälpte oss hela dagen med att lägga på takduk, ströläkt och bärläkt för ena takhalvan. De hann även fixa vindskivan på ena gaveln.

När vi tog fikapaus på förmiddagen, innan vi hade spänt fast hela takduken, kom vinden och gjorde sönder all ströläkt på ena halvan av taket...

Vi sorterade ut takplåtar i olika högar utifrån var de har sina skruvhål. Vi kom fram till fyra olika olika: 100 mm, 105 mm, 110 mm och 115 mm.

Därefter kapades de av till sin rätta längd: de var 2445 mm långa och de ska bli 2320 mm långa. Detta gjorde Elin med en vinkelslip med blad för metall. Alla plåtar hann inte kapas upp då bladet tog slut (förbrukningsvara).

För att kunna lägga på plåttaket behövs rännkrokar, skruvar, nockplåt och fotplåt köpas in. Vi gjorde en snabb koll på både Marketplace och Blocket men lyckades inte hitta det vi sökte. Det fanns något från Lindab, men det var antingen i svart eller röd kulör. Vi ska ha galvaniserad/metallic ytbehandling då takplåten (tp20) är galvaniserad.

Vi mejlade därför Wosab, ett plåtslageri i Stenungsund, och gjorde en beställning på dessa produkter. Det var viktigt att veta längden på plåten (längden på taket), taklutningen och takfotens mått.

Vi försökte även få tag på Joakim från Hunton för att beställa Hunton vindtät (asfaboard) men lyckades inte pga att han gått på påsklov. Vi får försöka på annat sätt då vi behöver ha dem till nästa vecka.

Galvaniserad plåt görs inte längre - svårt att hitta nytt. Om man kollar på plåten, som vi har, är kvalitén väldigt bra. Taket har hållit sedan kanske 1940-talet (uppskattad tid från Christian). Ny plåt är billig att köpa, men är "dyra" att tillverka. En orsak att återanvända gamla plåtar.

I vårt projekt är tidsbristen ett faktum och påverkar möjligheten att kunna återbruka. Enligt Christian kan det gå att hitta plåt detaljer begagnat, men det kan ta tid att hitta och det kan framförallt vara väldigt svårt att hitta galvaniserat. Kan vara så att man själv får åka till stället och plocka ner det gamla... (Christian).

Tisdag 14/4

Åkte och hämtade asfaboards på Hunton Konstruktion i Olsfors vid kl 7 (när de öppnade). Vi hade ingen aning om de hade det på lager eller inte, vi bara drog dit... Vi hade tänkt att ha 19 mm boards för att kunna återbruka restprodukter från Hultet, men det visade sig att de endast hade 25 mm på lager och att det i så fall skulle behöva beställas 19 mm asfaboards från Norge (vilket skulle försena hela bygget). Så vi bestämde oss för att köra på 25 mm för att kunna påbörja monteringen av dem idag.

Kom till Egnahemsfabriken strax innan kl 9. Började med att montera asfaboards på väggarna. Vi använde pappspik då man inte kan skruva i asfaboard pga att skivan är såpass porös så den går sönder av skruven.

Efter lunch åkte Raed och hämtade plåtbeställningen från Wosab i Stenungsund. Vi gick över till taket och hann montera fast rännkrokar, fotplåt och takplåt på ena halvan av taket.

Onsdag 15/4

Monterade upp andra halvan av taket (rännkrokar, fotplåt, takplåt ochnockplåt). Sågade ut och satte fast vattenbrädor också. Upptäckte att hålen, som inte träffade någon bärläkt, måste lagas på något sätt. Hade en lång diskussion med Christian, Raed och Wosab. Kom fram till att vi skulle skruva i plåtskruv. De flesta hål gick att laga med plåtskruv vi hade haft till nockplåten, pga de såg ut som tulpaner så vi kunde slå igen dem. Resten lagade med 6,3 plåtskruv, som Raed åkte och köpte på Wosab.

Taket blev klart tillslut och monteringen av asfaboard fortsatte tills pappspiken tog slut.

Torsdag 16/4

Part 3 - måste ha allt material innan bygget påbörjas. Väldigt kritiskt i större projekt då arbetskraft kostar och bygget inte kan stå stilla, kostar alldeles för mycket. Viktigt med lagerplats men får inte kosta för mycket, måste vara ekonomiskt försvarbart att återbruka.

Fick byggvarudeklarationen för Hunton träfiberisolering från Joakim. Såg att sluttillverkningen sker i Polen? (Hunton är norskt).