

# BÖLEBADET



**Klara Bergström**

Master Thesis 2023  
Chalmers School of Architecture  
Department of Architecture and Civil Engineering

Examiner: Mikael Ekegren  
Supervisor: Filip Rem



### Bölebadet

Author | *Klara Bergström*

Supervisor | *Filip Rem*  
Examiner | *Mikael Ekegren*

Chalmers University of Technology  
Department of Architecture and Civil Engineering  
Master's Thesis Direction: Building and Tectonics  
Master's Programme of Architecture and Urban Design

## ABSTRACT

This thesis explores how a public river bath in Umeå, Sweden, can be designed to accommodate the traditional Nordic bathing rituals, and how architecture that encourages sensory experience can create a stronger connection to the natural surroundings.

Located close to the city centre of Umeå, about 2 kilometres upstream, lies a small set of islets called Bölesholmarna. These islets are part of a recreational walking trail connecting the north and the south side of the river. The cold bathing facility will float just outside of the western point of the islets and can be viewed as an extension of this trail, thereby connecting the bath to the busy city centre through another outdoor activity. The design of the building creates a connection with the surrounding environment, directing the attention to the river and encouraging visitors to slow down and appreciate the natural beauty of the area. The history of log driving on the site will be explored and used as reference in the building's façade.

The design of the building is based on the notion that partaking in a ritual can strengthen the connection to place through repetition and sensory experiences. By designing for the traditional act of sauna bathing, a deeper connection between people and their environment can be evoked. The thesis will therefore cover the background and history of the Swedish sauna bathing, as well as aim to describe why it has become such an important and integral part of our culture. By mapping out its historical and cultural importance, the goal of the thesis is to use it as a design tool, and through research by design propose a space meant for the experience of the ritual. And by doing so further enhancing our presence in nature, in order to take better care of our planet and ourselves.

*"The relationship between place and culture allows us to know and love ourselves and our community. ... This love of place is critical for our planet..."*

Barbara Erwine,  
*Creating sensory spaces*

### Keywords:

sauna | cold bathing | ritual |  
culture | sensory experience |

## THANK YOU

Filip Rem | *Supervisor*

Mikael Ekegren | *Examiner*

External critics

Fellow students at Chalmers

Friends and family

Abrar

Kalle

## STUDENT BACKGROUND

2021-2023 M.Sc Architecture and Urban Design  
*Chalmers University of Technology*

*Studios:*  
*Matter, Space, Structure 3*  
*Housing inventions*  
*Material & Detail*

2017-2020 BFA in Architecture  
*Umeå School of Architecture*

## CONTENT

### I | INTRODUCTION

Purpose & Aim, Thesis Question	6.
Method & Delimitations	7.
Background	8.
The Swedish bathing history	10.
The Swedish sauna revolution	12.
Multisensory design	14.

### II | REFERENCES

Kallbadaren	18.
Strandängens kallbadhus	20.
Community Centre Spinelli	22.

### III | SITE

Information	26.
History	28.
Analysis	30.
Images	32.

### IV | PROPOSAL

Space and program	36.
The plan	38.
The situation	40.
Site plan 1:400	42.
Site section	44.
The facade	46.
Elevations	50.
Sections	54.
The ritual	58.
Structural concept	64.
Details	66.

### V | CONCLUSION

Conclusion	74.
Reference list	76.

I

INTRODUCTION

## PURPOSE AND AIM

The purpose of this thesis is to investigate how architecture can facilitate a stronger connection to a place, with a specific focus on exploring how the sensory experiences of Nordic bathing rituals can be used as a framework for design.

The aim is to identify and define the sensory moments that occur during the ritual of sauna and cold bathing, and to consider these transitional and contrasting concepts in the design process.

Further, the aim is to create a space where the sensory experience is reflected in the design choices, specifically in relation to the activities of the ritual.

This thesis will primarily focus on exploring the relationships between the building, the natural surroundings, and the human body. Ultimately, the goal is to discover how architecture through sensory design can be used to promote a more profound sense of presence and connection to place.

## THESIS QUESTION

How can the design of a public river bath facilitate a stronger connection to the surrounding nature through the ritual of sauna bathing?

## METHOD

The main method used in this thesis will be research by design, through iterations and spatial investigations.

The thesis will be divided into three phases, where phase one is primarily focused on gathering information, studying reference projects, Nordic bathing history and relevant literature.

The second phase will narrow in on the chosen site, focusing on analysing and mapping the area, looking closer at the history of the river and how to incorporate location-specific aspects.

The third phase will lastly focus on the implementation of the notions and concepts that has emerged in previous phases. Iterations of the design as well as discussions with tutors and peers will be of importance to this part of the project. The outcome of this phase will be a full design proposal with drawings, perspectives, and models.

## DELIMITATIONS

The outcome of the thesis will be a speculative design of a floating bath in Umeå river. The thesis will not be considering current shoreline protection regulations, as this would be restricting the design and the study, nor will it focus in on the specifics regarding technological solutions of the floating pontons.

## BACKGROUND

The Nordic ritual of bathing, and especially sauna bathing, dates far back. The sauna has served an important part of Nordic culture ever since the Middle Ages and has been considered sacred in Finland for centuries. It has been used in many ways, serving as both birthplace, drying room, and hygiene facility, among other things.

Nowadays the sauna is mainly used for recreational purposes and can be found in many Nordic homes and summer houses. It might not be used as a birthing facility anymore, but the sauna is still commonly visited, and a prominent part of the Nordic heritage. Architecture can play an integral part in preserving and reinforcing this heritage. Through architecture and experience we can strive to strengthen our sense of belonging. An important aspect of that connection relates to how we perceive our surroundings, and how we view ourselves in relation to nature and place.

The relationship between sauna bathing, cold bathing and nature is quite evident, in that we use the combination of inside and outside spaces to perform this rite. The rite itself is based on sensory events, where the contrasts of hot/cold and humid/dry are central to the experience. I therefore want to investigate how the experience

of the sauna rituals and the cold bath can work together with architecture, in order to make a stronger connection to our natural surroundings.

*"To at least some extent every place can be remembered, partly because it is unique, but partly because it has affected our bodies and generated enough associations to hold it in our personal worlds."*

Kent C Bloomer, Charles W Moore  
*Body, Memory, and Architecture*

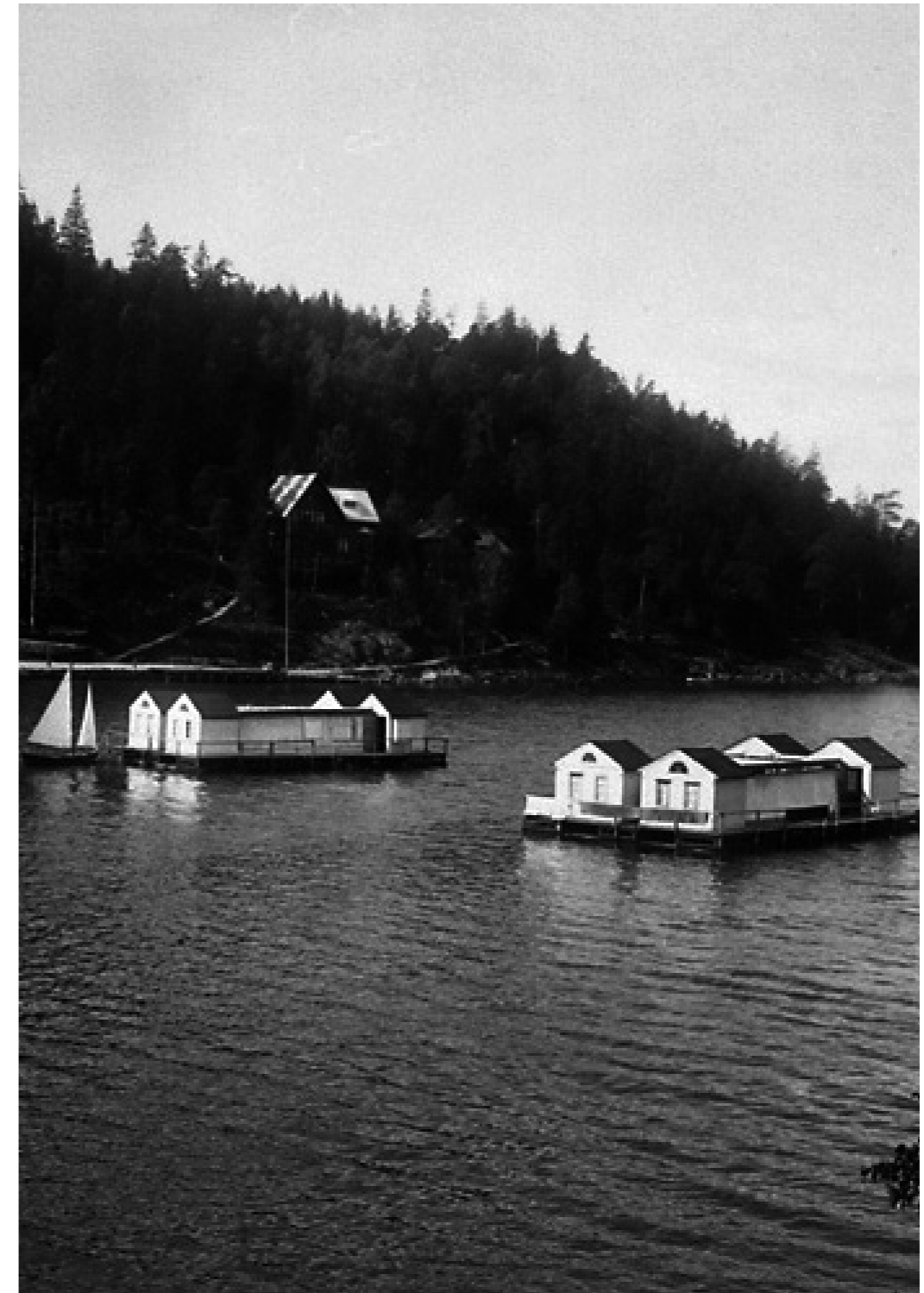

*Fig.1 Floating bathing facilities, Gustafsberg, before 1910. Lundbäck, M*

## THE SWEDISH BATHING HISTORY

The sauna came to Sweden with the Vikings. They had come across sauna bathing as they were rummaging the east and would build their own versions as they got home from their travels. During the Middle Ages influences from Constantinople also paved way for further communal bathing in the Nordic countries. (Kindblom, 1995) However, due to fear of syphilis and fornication the continental bath houses started to close during the 1500s, and in Sweden the same thing occurred in the 1600- and 1700s. The bath houses and the saunas were prohibited, since it was considered to promote pagan activities, and for the most part of the 18th century the Swedes would remain dirty and unhygienic. Still, some of the sauna culture remained active in parts of Värmland and in the northernmost part of Sweden, due to a denser Finnish population. (Wiell, 2018)

In the early 1800s various health resorts began to pop up in Sweden, primarily on the west coast. This was a way for the high society to socialize and promote their health, as it was considered medicinal to bathe in the mineral springs and the salt water of the sea, so called hydrotherapy. (Wiell, 2018) It was also at this time Swedes started cold plunging, or kallbada. At first the cold bathing facilities were floating structures on the water, where male and female visitors were clearly divided into different houses. Later, these

structures would become larger, and house both genders. Communal bathing was now normalized and new ideas about nude baths were even expressed due to central European influences. (Kindblom, 1995) Despite these new structures, however, the Swedes were bad swimmers, and scared to go in the water. In the beginning of the 20th century, a typical Swede would bathe perhaps but 3 times a year. (Frykman, 2004)

This, however, was about to change during the interwar period, as the sauna bathing was promoted as an ideology of order, and for a city to have a cold bathing facility was considered highly attractive.



Fig 2. Bastubad, Bjurbäcken 1911  
Keyland, N

## THE SWEDISH SAUNA REVOLUTION

Due to the poor hygiene of the Swedes during the turn of the century, the health-related advantages of sauna bathing were highlighted, and the Finnish sauna was considered a good example of a hygiene institution. Henrik Berg wrote in his book *Lärobok i Hälsolära*, 1891: *“Måtte den gamla bastun åter komma till heders! En sådan borde byggas vid hvarje by.”* (“*May the old sauna be honored again! One like this should be built in every village.*”)

The reason why the sauna specifically became the conventional washing facility for the public in rural areas is most likely because of its low operating costs and overall efficiency, where many people could clean themselves at the same time, using only a little water and some firewood. It was also considered to be health promoting in a physical sense, with the ritual of the bath instilling pleasure, as well as offering the appeal of social community. This was the start of what can only be described as a sauna revolution, where after centuries of hesitation and fright regarding water safety, the Swedes would get bathing again. (Wiell, 2018)

In Jonas Frykmans chapter of the book *Tio tvättar sig*, 2004, he describes the culturally sensitive act of sauna bathing. He states that the sauna rites are not only concerning cleanliness, but also touches

on notions of community and moral. It is a physical activity, one where the extreme alteration in temperature causes bodily pleasure and relaxation. It is a rite that must be described through the place, the body, and the material. It is a mark of Nordic pleasure, a cultural phenomenon beyond borders. (Frykman, 2004) A place of presence, where the contrasts in temperature and humidity drives us to let others in, or to just be in our bodies. It is in a sense a very special form of public place, where people meet and come together, and the testing of our bodies becomes a collective game. We move around to alter the intensity of the heat and ask our neighbours if they feel like taking a cold plunge, roll around in the snow, or if it is okay to add more water to the hissing stones.

Frykman goes on saying that even though the goal of this sauna revolution perhaps was to ensure a healthier population, other values came with it. The Swedes saw an opportunity to use the sauna for pleasure, and thereby guaranteed the saunas cultural endurance. (Frykman, 2004)



Fig 3. Bastubad, Bjurbäcken 1911  
Keyland, N

## MULTISENSORY DESIGN

*“The job of a designer is to orchestrate the sequence of sensory experiences to increase the probability of delight”* Barbara Erwine claims in her book *Creating sensory spaces*. She states that it is our job to choreograph the flow of a building, aiming to ensure a certain experience. Erwine goes on describing that it is in the design of transitions between sensory experiences that we can strengthen the connection to the place itself, highlighting the importance of rhythm and flow in contrasting notions. (Erwine, 2017)

Working with contrasting notions is of importance for how we perceive our surroundings. Erwine goes on stating that *“for something to be noticed it has to emerge from the background.”* This is true also regarding sensory experience. *“We sculpt sensory space using both sides of the sensory continuum of contrast.”* In designing the transitions between contrasting moments of a sequence, the experience of it can expand. As for spaces for bathing, contrasting sensory experiences such as hot/cold, wet/dry, light/dark, can be utilized it as design tools. (Pearson, 2020)

Through our senses we can perceive invisible borders. These perceptions overlap with the tectonic space it corresponds with and makes the experience of the space richer and more complex, as we can perceive it in different ways based on personal

connotations to past experiences. (Pallasmaa, 2012)

How we perceive space is a phenomenological matter in which many factors will be at play, for example where we grew up, how we identify and past experiences. We all carry bodily memories of experienced space – and they all affect how we identify with our surroundings, our culture and our past. They enhance the sense of belonging through tapping into our collective cultural memory. As Lisa Heschong describes in *Thermal delight*, *“Through ritual, a place becomes an essential element in the customs of a people.”* (Heschong, 1979)

The importance of multisensory experiences in architecture relates to the love of our surroundings that is crucial for the benefit of the environment. It is in the connection between man and nature, and man and place where we will thrive, and through architecture that strengthens the connection to place, this can be achieved. (Erwine, 2017)



*Fig.4 Snow, water and ice, Umeå, 2019. Bergström, K*

II

REFERENCES

## BADPALATSET

*Name: Badpalatset*

*Location: Stockholm, Sweden (Not built)*

*Architects: AndrénFogelström*

*Year: 2020*

This project is the winning proposal for a new public cold bath in Stockholm, that was set to be built in 2021 but was post-poned due to planning regulation issues. The bath is designed as a meeting spot for the residents of Stockholm and can be used both during wintertime and summertime.

The building is organized in such a way that it separates the dry and wet areas, dividing the plan into three different zones - the dressed zone, the undressed zone and the bathing clothes zone. The saunas are placed to give the users the best possible view of the surroun-

dings, and centrally in the building lies a common sauna and a wind protected bath.

I chose this project as a reference for my bath as I believe that the architects of Badpalatset have succeeded in arranging the space of the building well, and because of how the flow of the building is designed. Additionally, similarly to Bölebadet, Badpalatset is a floating construction with a strong wooden expression. Though larger in size, many important aspects of this project could be incorporated in my project as well.

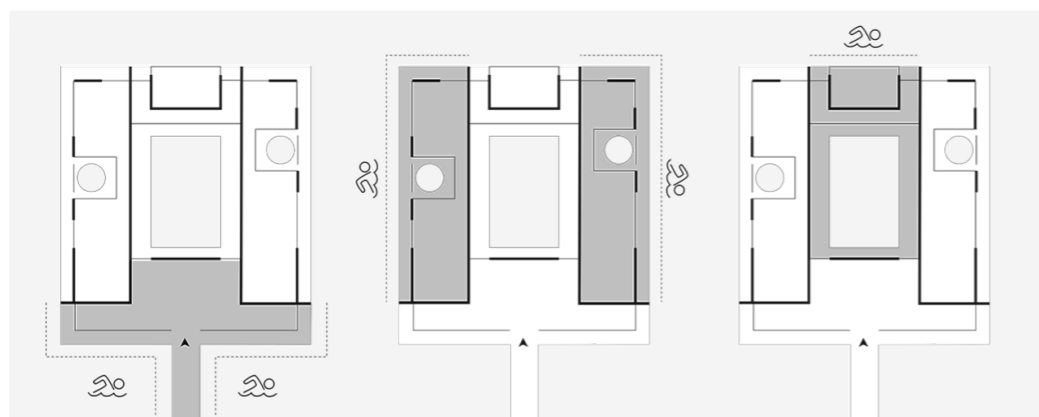

*Fig.5 The dressing zones of Badpalatset.  
AndrénFogelström. (2020)*

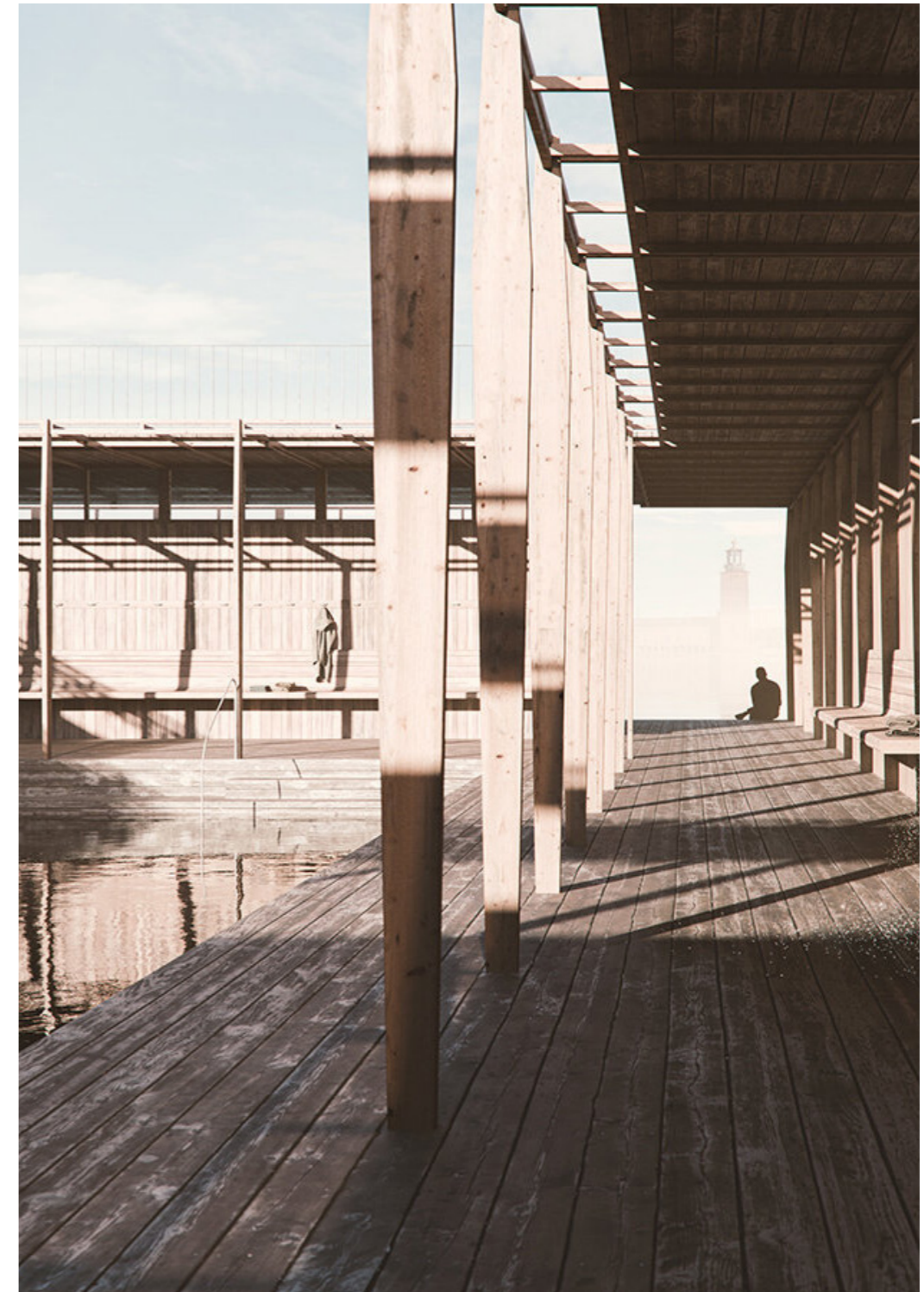

*Fig.6 Interior view of Badpalatset,  
Katzenwaffe. (2020)*

## STRANDÄNGENS KALLBADHUS

*Name: Strandängens kallbadhus*  
*Location: Jönköping, Sweden (Not built)*  
*Architects: White arkitekter*  
*Year: 2019*

Similarly to Badpalatset, this project is a winning proposal waiting to be built. This is also a public cold bathing facility, located in the Jönköping area, close to the lake Vättern.

Strandängens kallbadhus is a wooden building that aims to harmonize with the surroundings. The building stands on stilts in the water, approximately 30 meters from the shoreline, and the main material used is environmentally classed/eco-labelled and resistant wood, and

the protruding wooden elements on the facade create an interesting shadow play.

The robust wooden material is both beautiful and resilient, and at the same time a sensory delight. In addition to the bathing and sauna areas there is also a warm lounge area with a fireplace and a pantry. The notions and plan layout of Strandängens kallbadhus have influenced the design of Bölebadet.



*Fig.7 Strandängens kallbadhus plan*  
*White Arkitekter. (2019)*

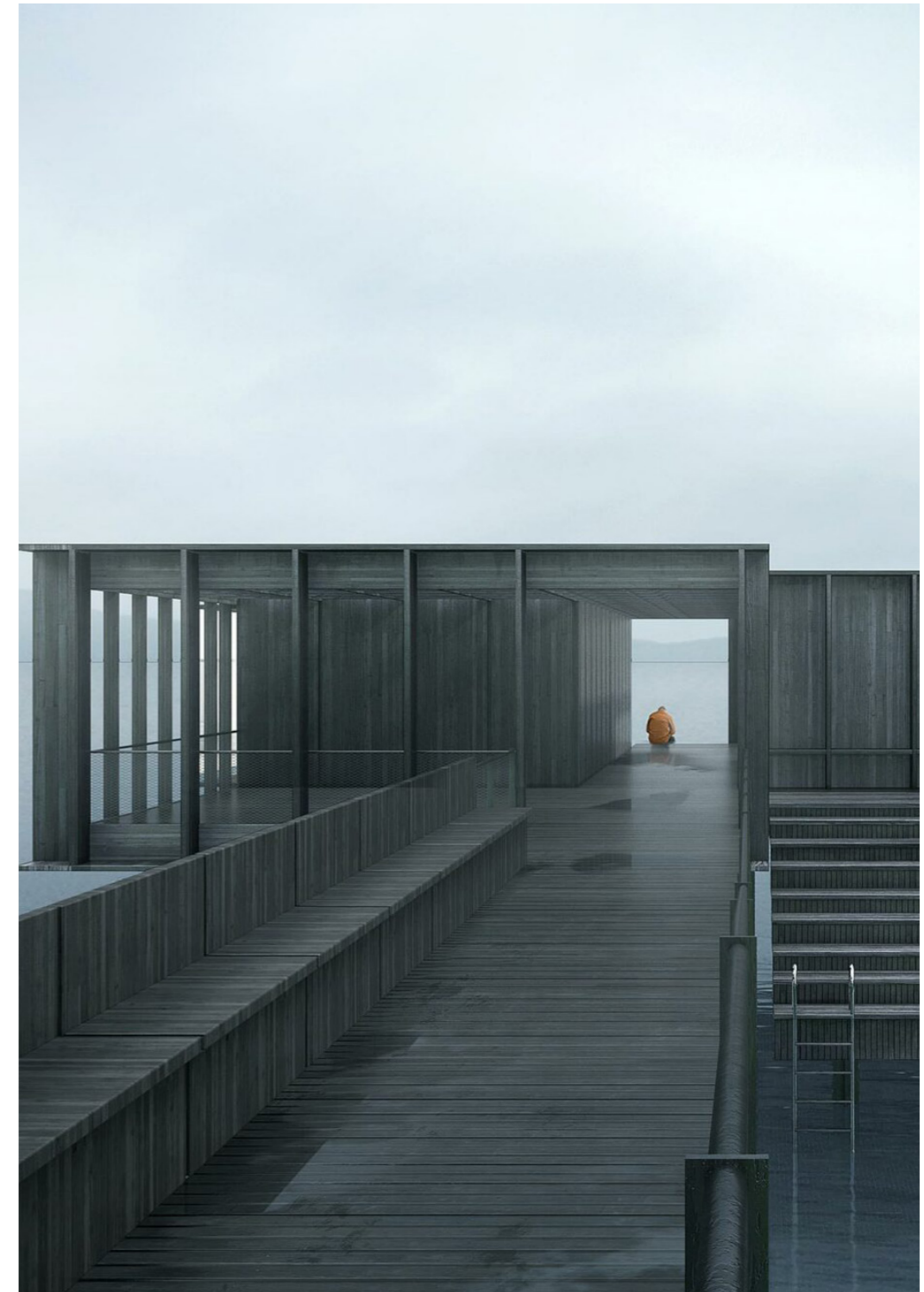

*Fig.8 Strandängens kallbadhus, exterior view*  
*Aesthetica Studio. (2019)*

## COMMUNITY CENTRE SPINELLI

*Name: Community centre Spinelli*  
*Location: Mannheim, Germany*  
*Architects: Atelier U20*  
*Year: 2016*

This is a collaborative project between refugees and students, located in the area of a refugee camp in Mannheim, Germany. In the camp, the lack of quality common spaces and stimulating surroundings sparked the need for an architectural addition that could provide the area with a more pleasant common experience.

The resulting building is made from structural timber elements and surfaces that has been left

untreated, and the visible relief-like expression of the facade is a play with structure and ornament.

I have used this reference as I too have worked with a wooden facade that should be rich in expression, and where the structure is visible as a rhythm on both sides of the wall.

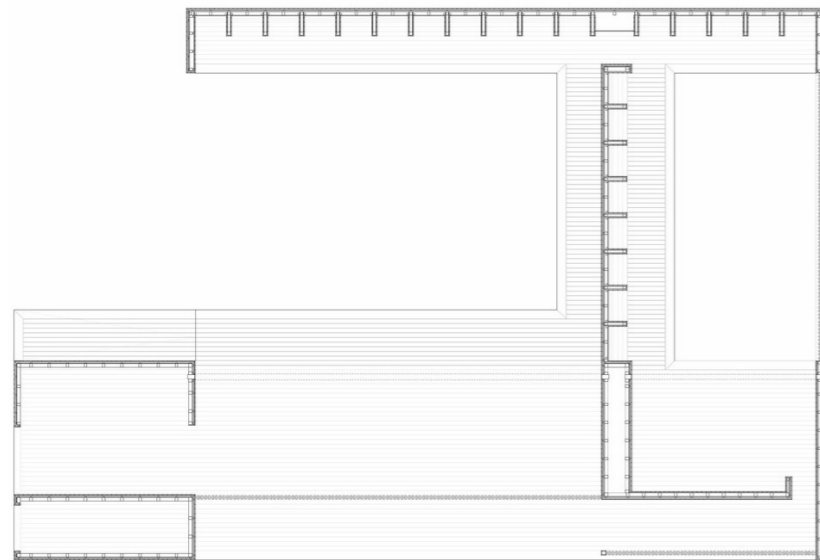

*Fig. 9 Community centre Spinelli, plan*  
*Atelier U20. (2016)*

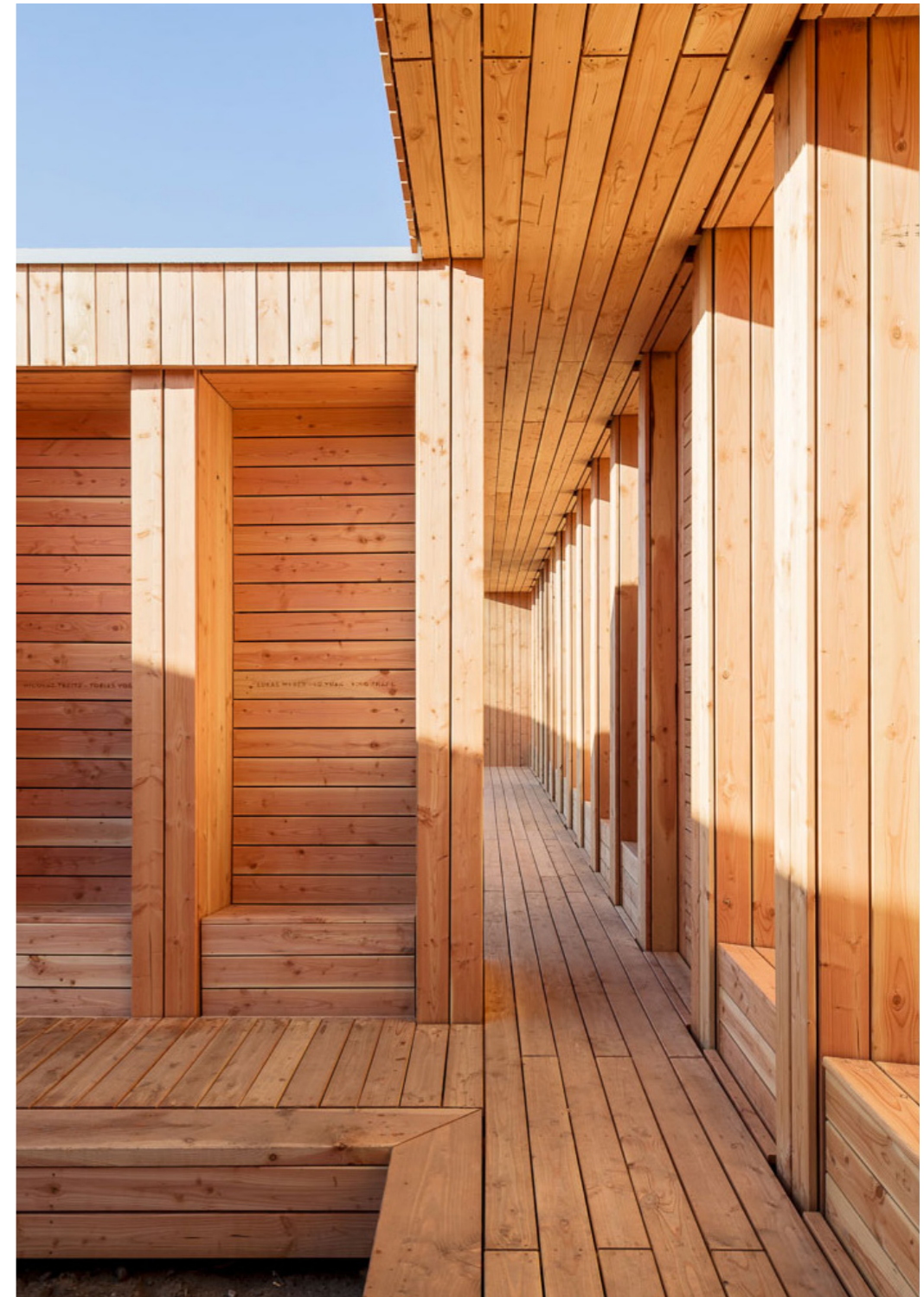

*Fig.10 Community centre Spinelli facade*  
*Wegner. Y (2016)*

III

SITE

## THE SITE

Located circa 2 km from Umeå city center lies Bölesholmarna, a couple of manmade islets that are part of a recreational area. The area consists of walking paths among the water and trees and can be seen as a calm and tranquil oasis in the Umeå region. On one of the islets, Gröna oxen, lies a beach, and there is a Japanese garden located just south of the islets.

To get to the site you could walk along the river on both sides, thanks to the new bridge connecting Bölesholmarna to the north side of the river. There is also a possibility to get there by car, with parking areas near the islets on both sides of the river. Close to the bridge mount on the north side, a new park is under development, with walking paths, fire pits and an activity rental.

As the city of Umeå keeps on densifying, the need for a recreational area in proximity to the city centre is evident. Bölesholmarna will become one of those areas and will contribute to an attractive and sustainable living environment for the residents of Umeå. The small forest area at Bölesholmarna is classified as key biotopes and helps to create a buffer zone protecting the area against flooding. The expected rise in visitors and the need for recreation in the city is why I have chosen this as my site.

It is therefore important that my proposal for the site is not in competition with nature, but rather blends in and strengthens the connection between nature and human. (Umeå kommun, 2020)

Sweden

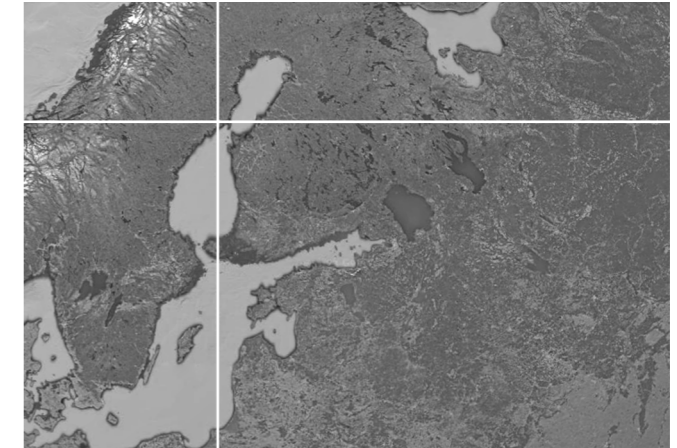

Umeå



Bölesholmarna



## SITE HISTORY

In a geological context, Bölesholmarna as we know them today, are quite young. However, the foundation of their existence was discovered during the beginning of the 11th century, as a result of the rising land and the subsequent erosion caused by the constant force and flow of the river. This in turn, revealed individual boulders where the islets now lie. (Umeå kommun, 2009)

The islets have gone through major changes since then, partly caused by the forces of the river, but also from human activity. Salmon fishing and log driving activities affected the currents of the river and thereby changed the shape of Bölesholmarna. (Björkman, 2022)

The log driving began sometime during the 18th century and kept developing as a system all through to the 1980s, when the era of log driving in Umeå river came to an end. (Björkman, 2022)

The islets themselves used to be a part of the log driving logistics, as they were used for timber storage before the logs floated further downstream, towards the island called Ön, where the logs would be sorted and marked before travelling further towards the coast.

Remains from the log driving era, can be found on Bölesholmarna and all along Umeå river to this day. (Ume älvdal, 2022)

1. Baggböleforsen
2. Nyhultet
3. Bölesholmarna timmermagasin
4. Umeå city center
5. Previous river bath location
6. Municipality planned river bath location
7. Gammhultet
8. Bölesholmarna beach
9. Gamla bron
10. Tegsbron
11. Kyrkbron
12. Öns skiljeställe
13. Kolbäcksbron



## SITE ANALYSIS

1. Planned park, under development
2. Lundabron, walking bridge
3. Beach
4. Grytan, old swimming spot
5. Boat harbor
6. Log driving remains

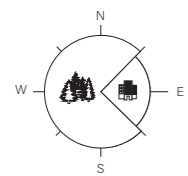

Views

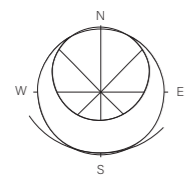

Sun chart

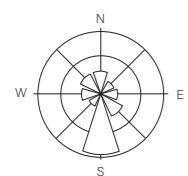

Wind rose



Bölesholmarna 1:7500

- |     |                   |   |                 |     |               |
|-----|-------------------|---|-----------------|-----|---------------|
| →   | Current direction | ∨ | Important views | P   | Parking areas |
| --- | Walking path      | X | Fire pits       | --- | Project area  |



*Fig.16 Umeå Älvdal  
Kjellberg. K (2023)*

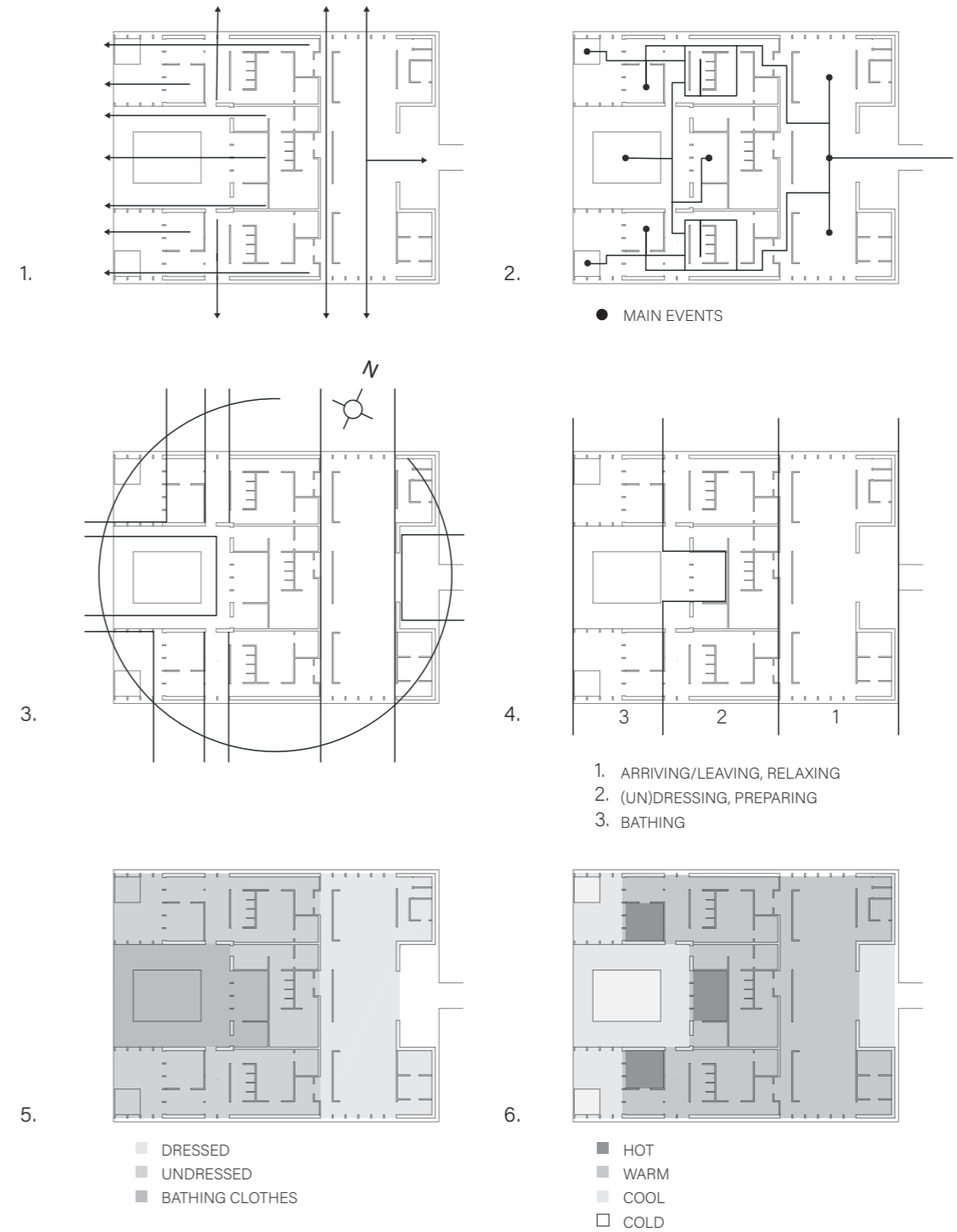
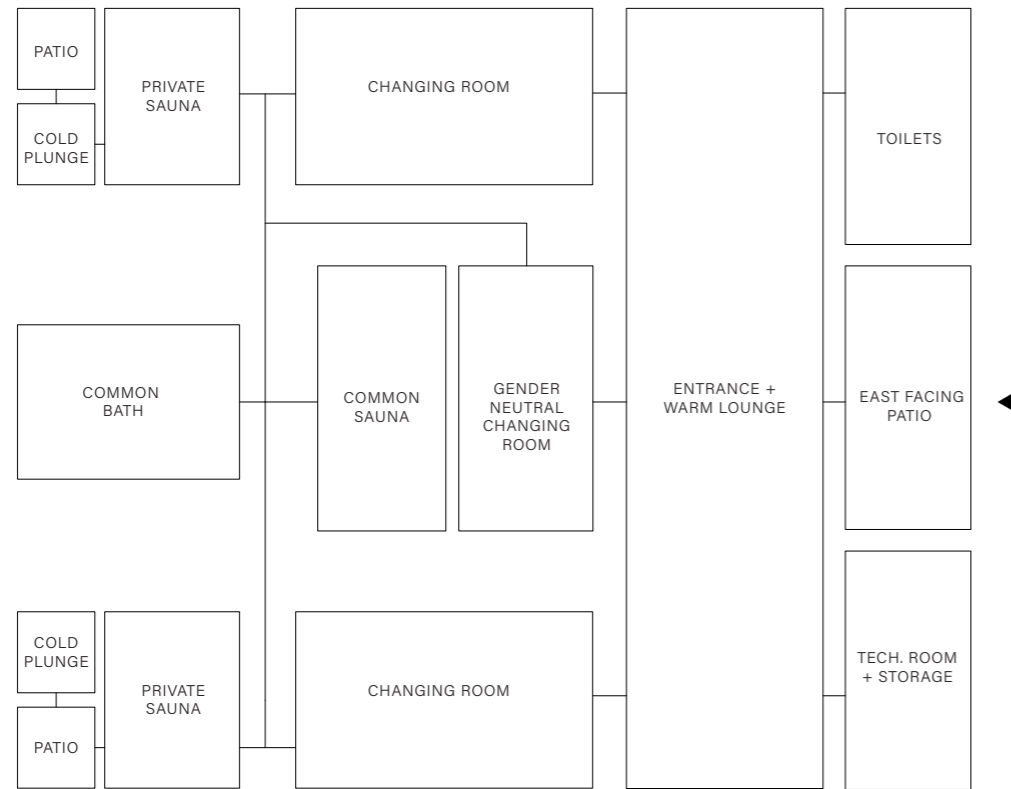

*Fig.17 Bölekanalen  
Kjellberg. K (2023)*

IV

PROPOSAL

## SPACE AND PROGRAM



### Program:

Warm lounge	185 sqm
Toilets	23 sqm
Technical room + storage	23 sqm
Changing room x2	76x2 sqm
Anteroom sauna x2	9x2 sqm
Sauna	15x2 sqm
Cold plunge + patio x2	35x2 sqm
Gender neutral changing room	52 sqm
Anteroom common sauna	9 sqm
Common sauna	18 sqm
Common cold plunge + patio	120 sqm

### Area:

Building area	533 sqm
Patios and plunges	230 sqm

### Plan concepts (right page)

1. Sightlines towards the river
2. The flow of the ritual
3. Sun relation
4. The moments of the ritual
5. Dressing zones
6. Thermal zones

## THE PLAN

The plan is designed in accordance with path of the sun, the rhythm of the ritual and the views of the river, these being important notions that I wanted to achieve.

The changing rooms are divided into male, female, and gender neutral, and the male and female changing rooms allow for naked sauna bathing and cold plunging. The cold plunges and the saunas, both the gender specific and common ones, are directly connected to the river, visually and in their location, pushing them as far west as possible, and at the end of the sequence. The smaller naked cold plunges, located at each end of the gendered changing rooms, and the larger common bath in the centre of the facility are directly connected to the river water, with ladders in each direction, allowing you to either follow or go against the flow or the river, enhancing the connection to the natural surroundings, and the experience of the body.

The sightlines reach the river in all directions as you travel through the building, making the presence of the river an essential part of the experience of the building and the bathing ritual.

Further, the moments of the ritual divide the building into a series of spaces and zones, designed to allocate the contrasting moments of the ritual, with separated areas for wet/dry, warm/cold, naked/dressed, and public/private.

### Program

1. Entrance
2. Fireplace
3. Toilets
4. Pentry area
5. Lounge area
6. Storage
7. Technical room
8. Gender neutral dressing room
9. Anteroom sauna
10. Common sauna
11. Common cold plunge
12. Entrance dressing rooms
13. Changing area
14. Showers
15. Sauna
16. Patio
17. Naked cold plunge

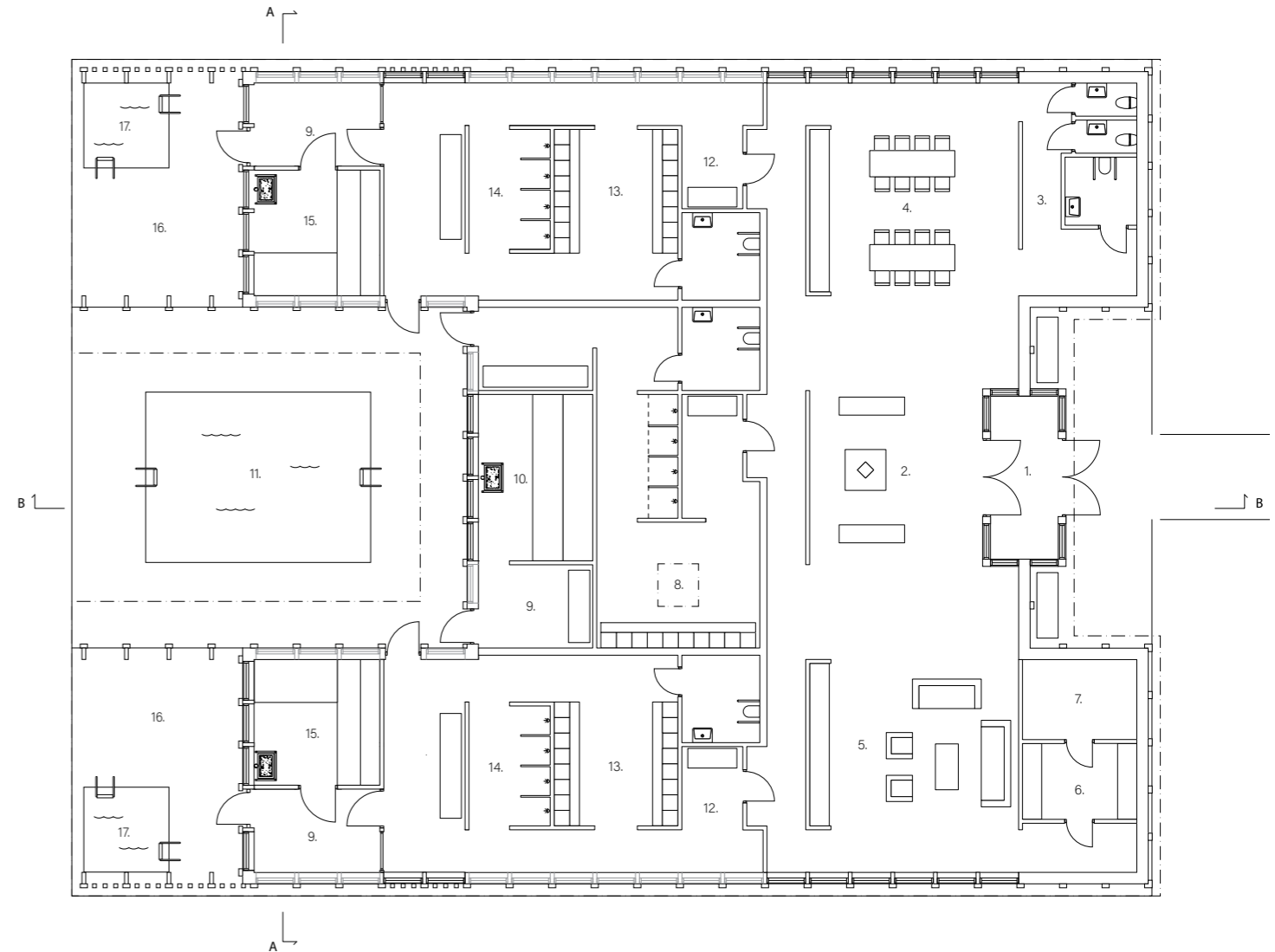

Plan 1:200

## THE SITUATION

The building is floating outside the western point of the islets, approximately 30 metres offshore, in order to preserve the sightlines from the existing path to the river.

The building can be viewed as an extension of the islets and has been rotated 25 degrees, following the direction of the islets out towards the river. The bath is visible from both bridges that connects the islets to the north and south shore, to attract visitors from both sides of the river. The more private areas of the bath face west, and are protected from view due to the distance to land.

On the tip of the island, where the bridge connects to the path, lies a fire pit area today, this will be preserved. There is a possibility to add seating areas on the bridge, with ladders emerging from the river to allow for swimming during the summer.

Parking can be done on the south side of the river, a short walking distance from the bath, and additional disabled parking spaces will be added in closer to the entrance.

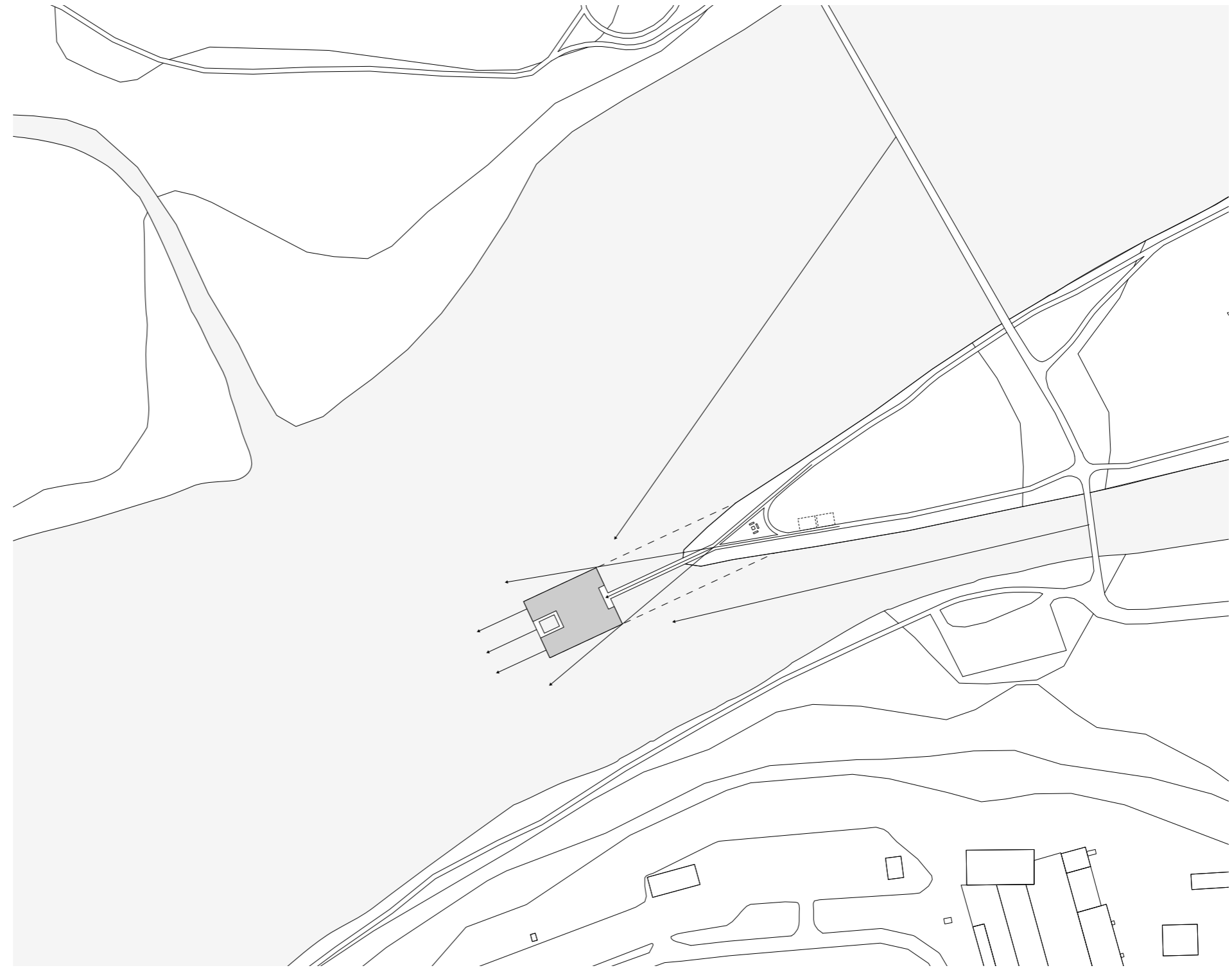

Site plan 1:2000

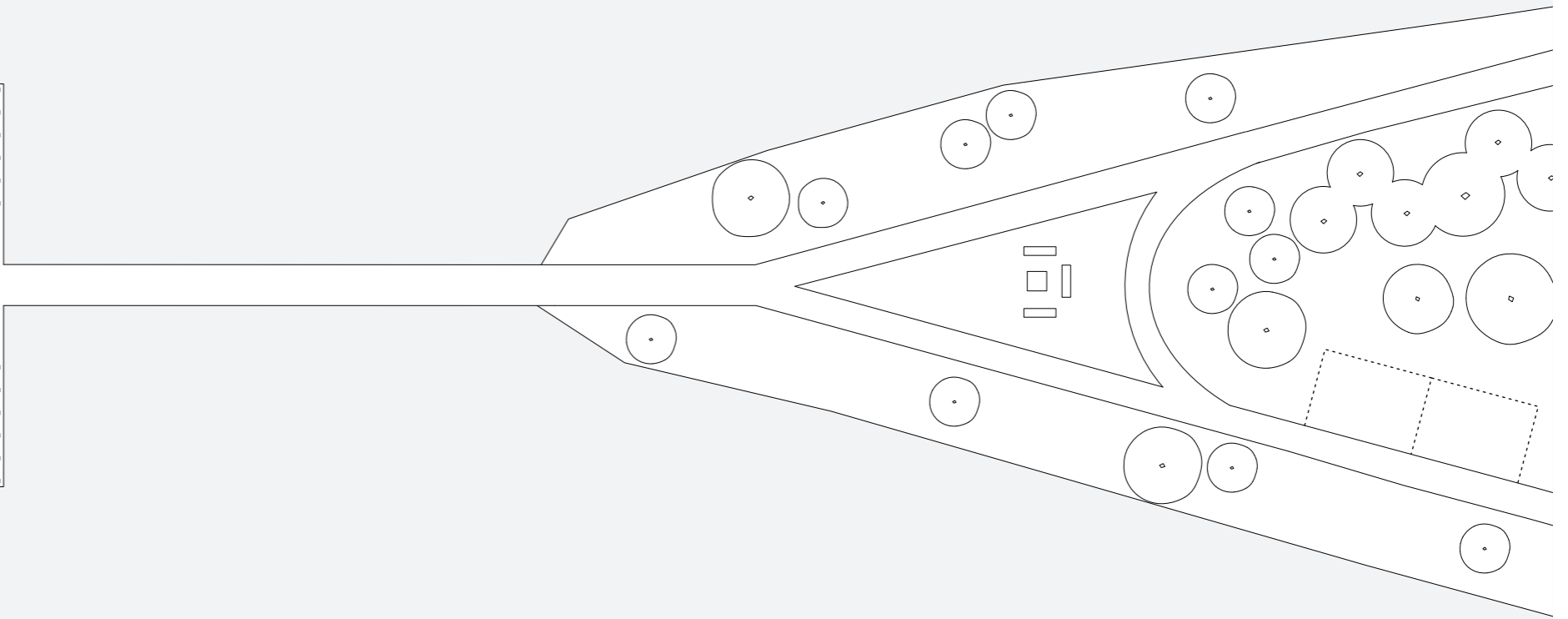
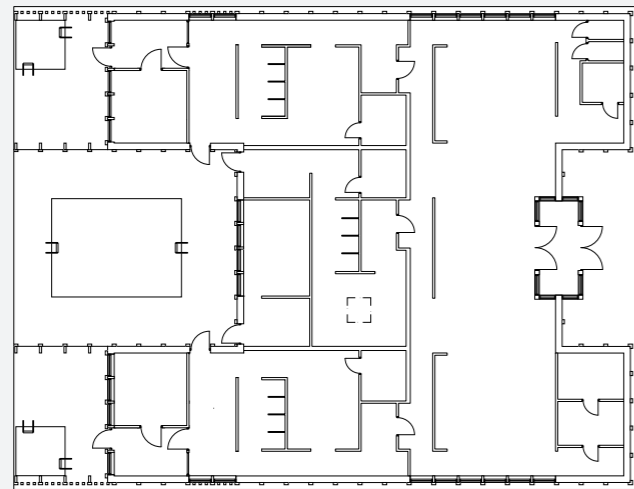

Plan 1:400

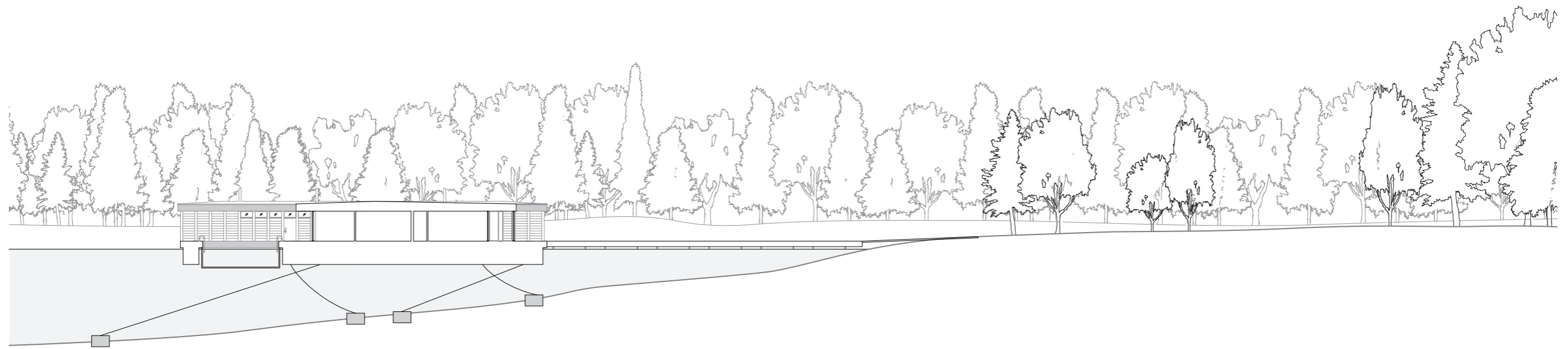

*Site section 1:400*

## THE FACADE

The concept of the facade is that of a strong repetition of large vertical wooden elements, that relates to the historic structures of the log driving on the site.

The repetition of the visible elements follows the structural grid of 1.3 metres, and mimics the repetition of the dam doors from the dams that regulated the water flow back in the logging period. The windows openings have been designed to look like the opening and closing dam doors, but in this case they open and close to let in light rather than regulate water flow.

The facade material is timber, as it was the most used material in the era for a very long period of time. And the dimensions of the facade expression have been heavily exaggerated, in order to represent the robust articulation of the structures of the past.

The dimensions have been translated, harmonized and conceptualized in the design, and used as inspiration for an overall expression that relates back to the history of the site.

*"Well, maybe the question of identity comes down to distinctiveness: that something becomes recognisable, has character and is a bit different from something else. And of course, as you said, there is almost a spiritual aspect of identity. I think there is character in good architecture. It creates place – place that you can relate to, and this produces identity."*

*Peter Zumthor  
in conversation with Juhani Pallasmaa,  
'New Nordic – Architecture & Identity'  
exhibition (July–September 2012), Louisiana  
Museum of Modern Art*

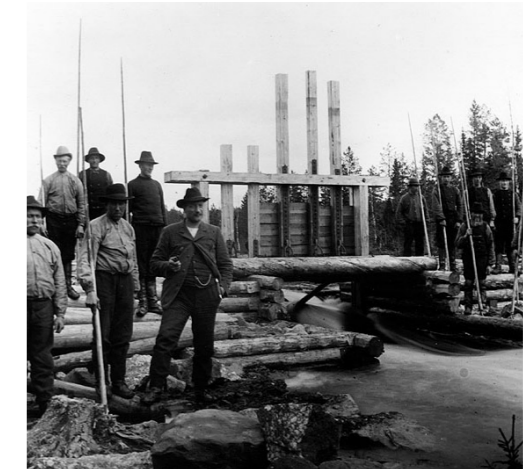
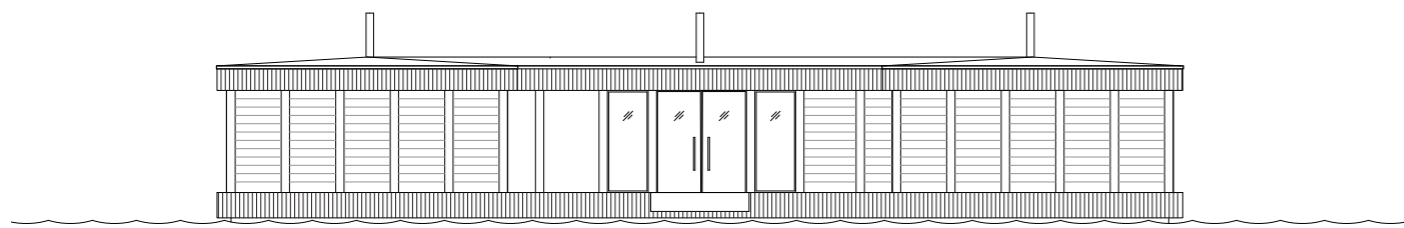
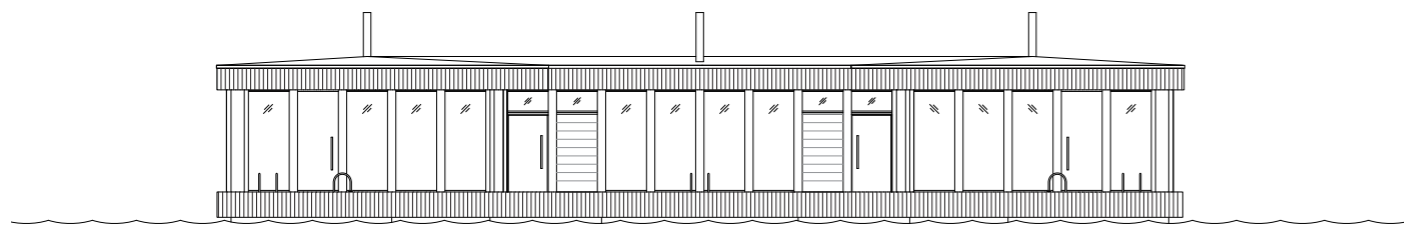

Fig. 18-23





EAST



WEST



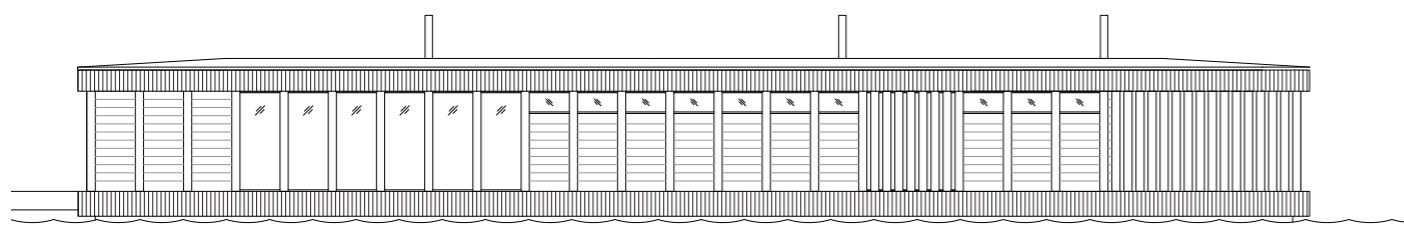

NORTH

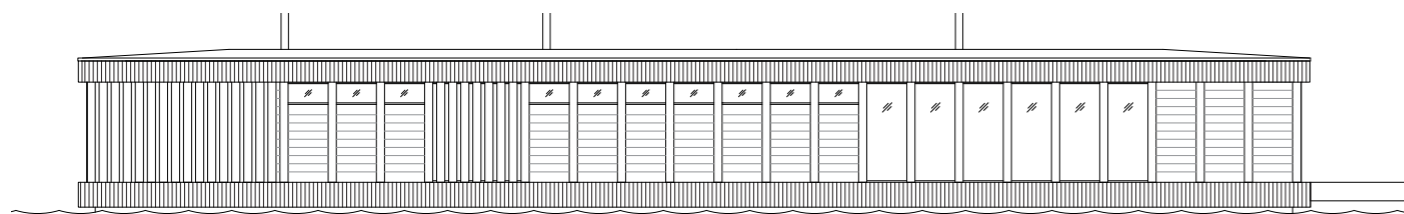

SOUTH



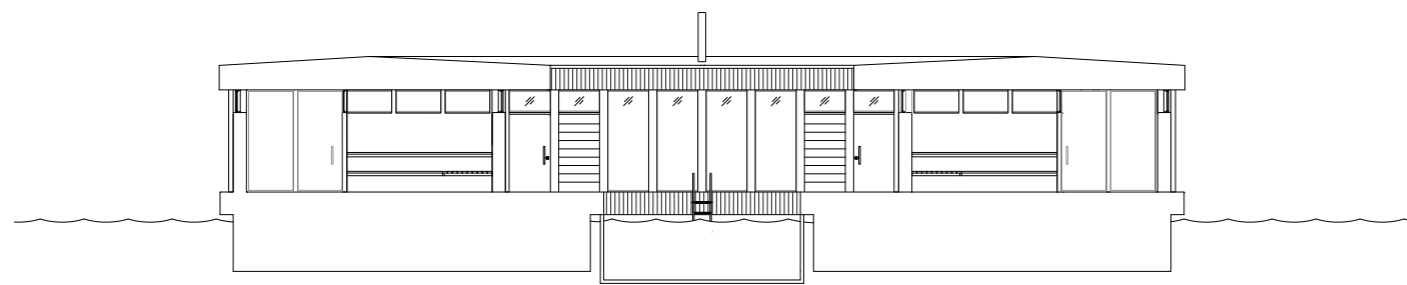

SECTION A-A

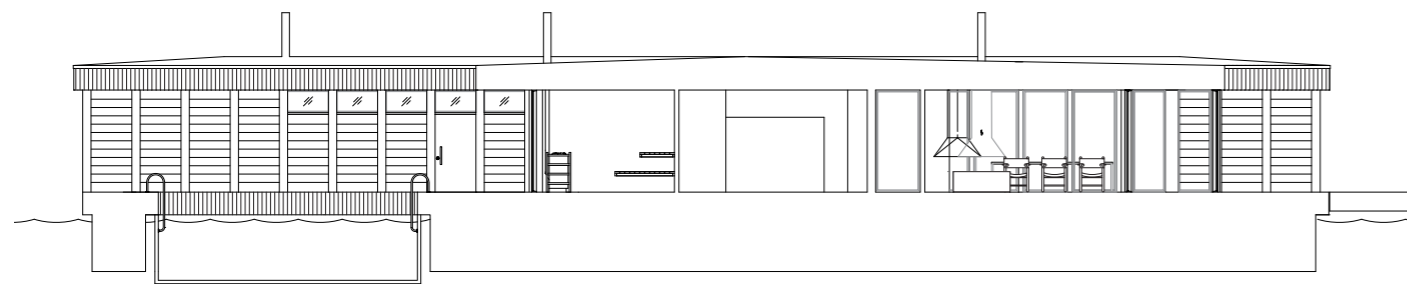

SECTION B-B

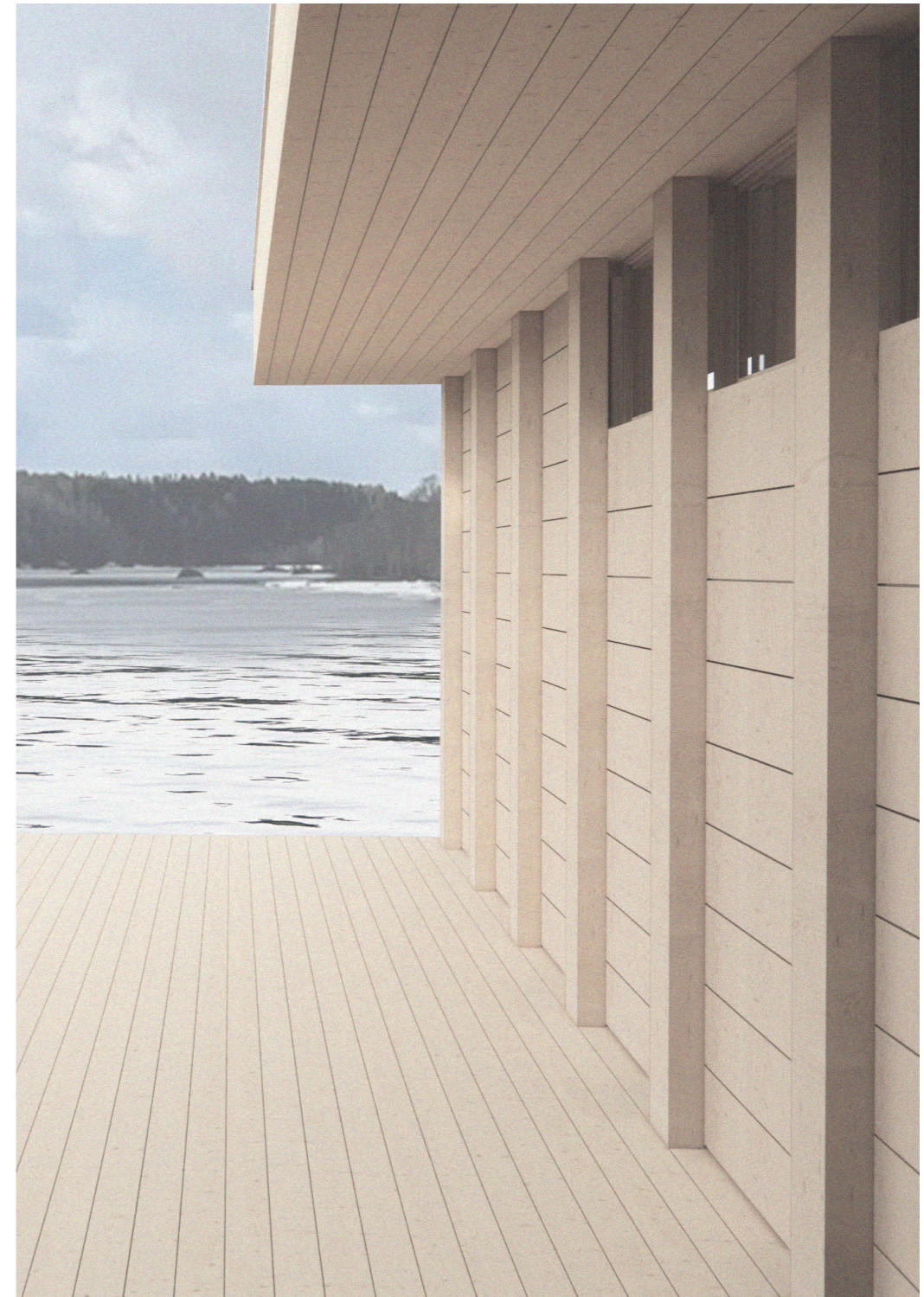



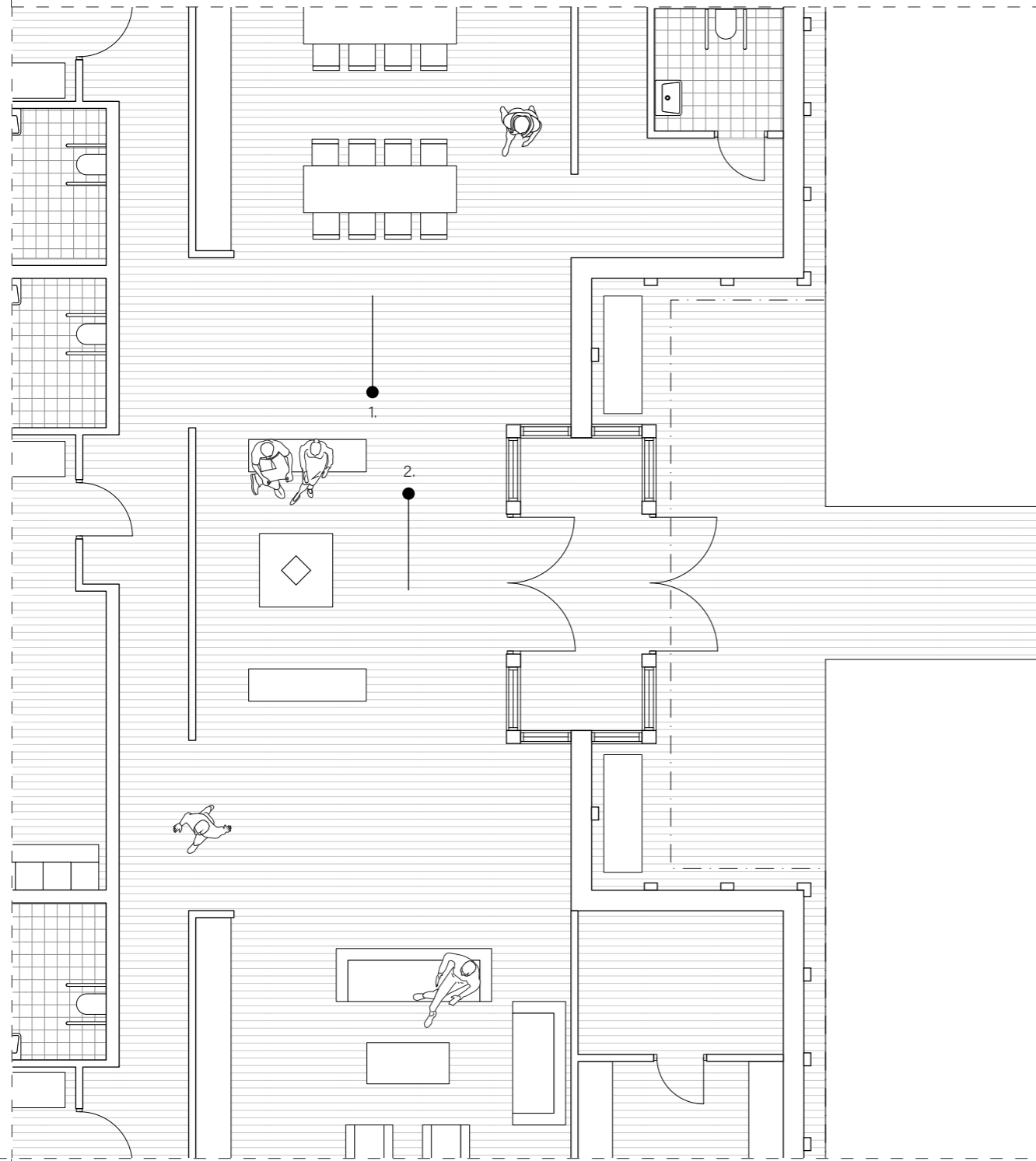

Plan 1:100



1. View of dining area and pentry.



2. View overlooking the warm lounge.

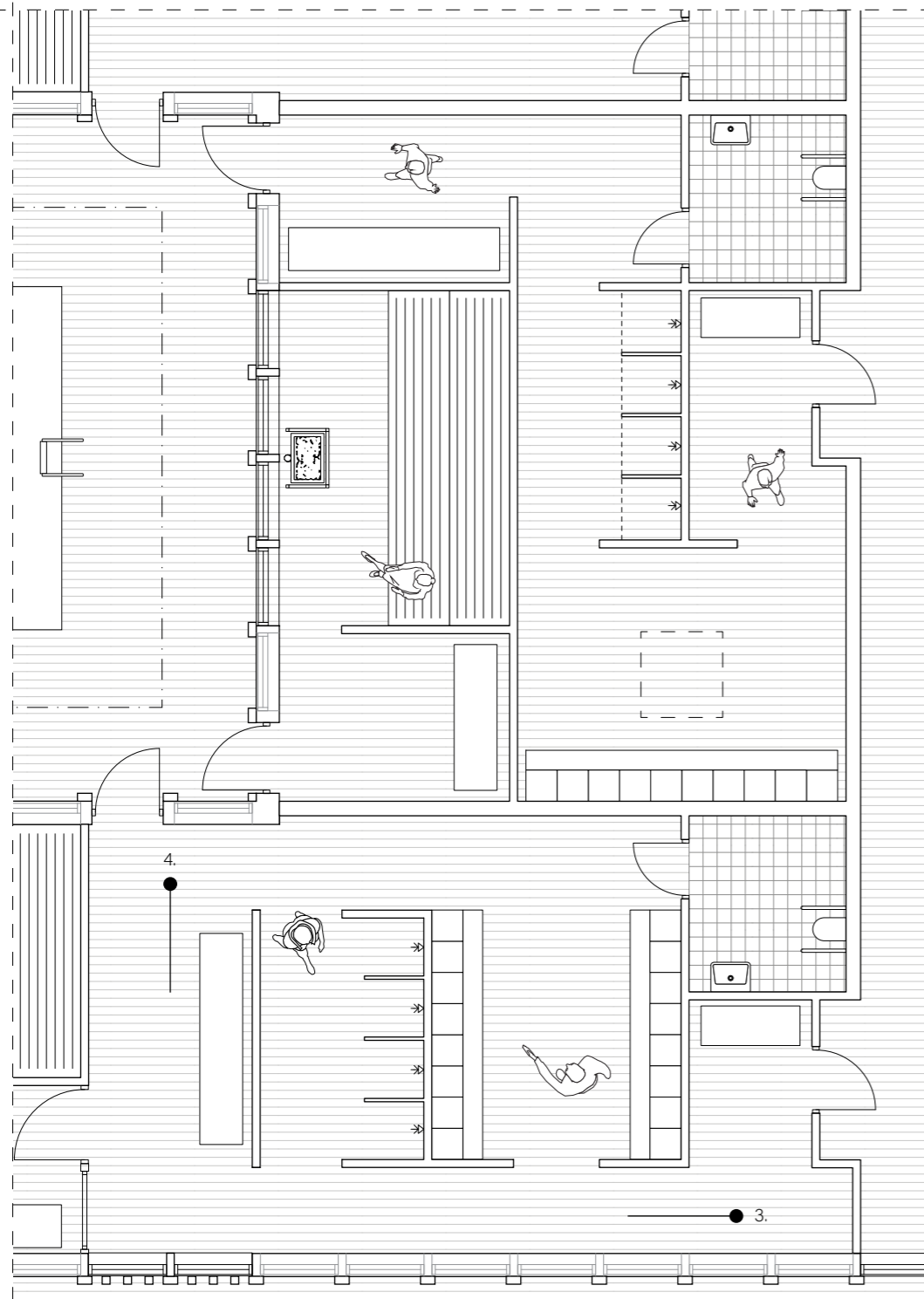

Plan 1:100



3. View towards the river in the changing room.



4. Protected view towards the river in the changing room.

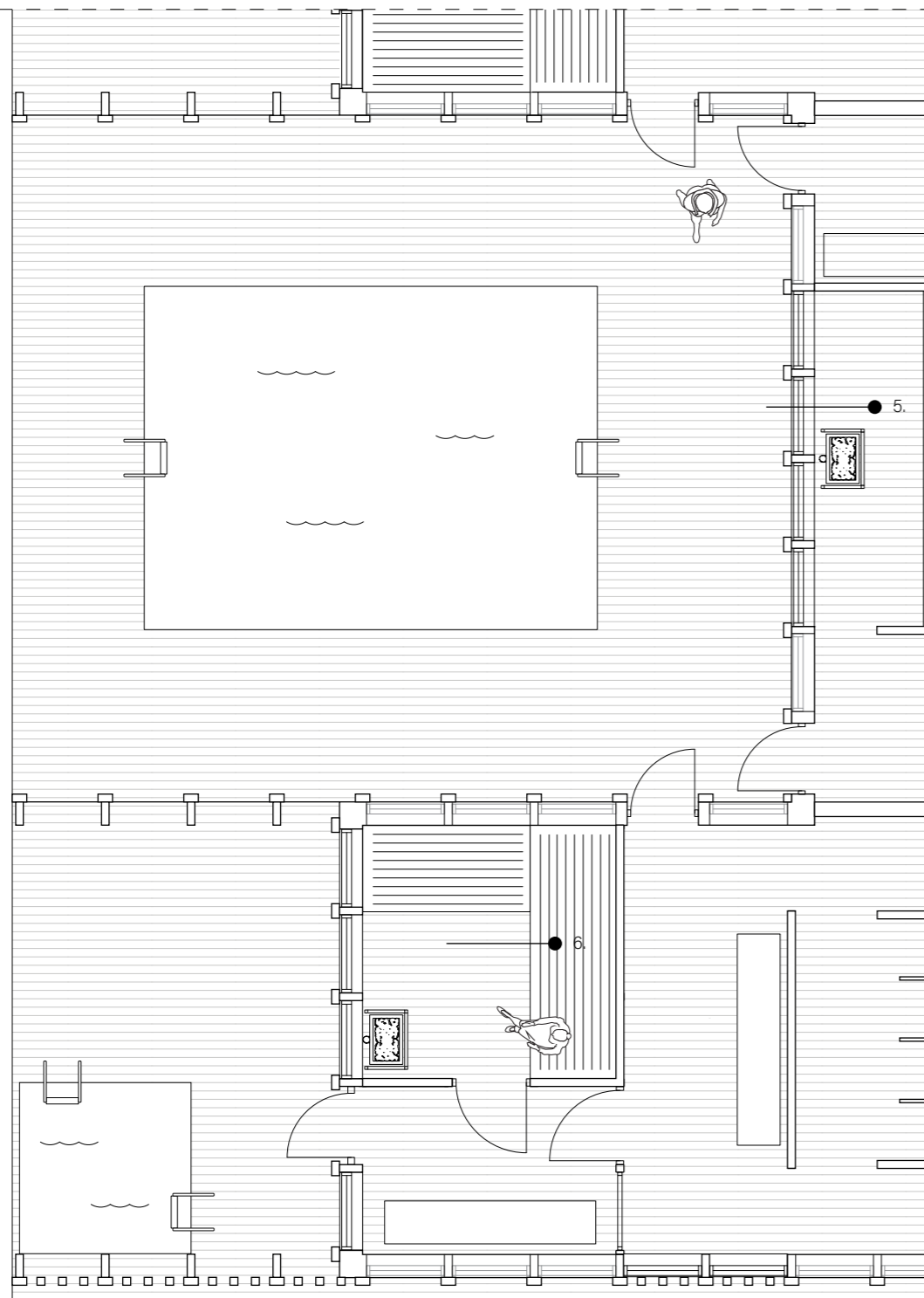

Plan 1:100



5. View from the common sauna



6. View from the private saunas

*Roof*

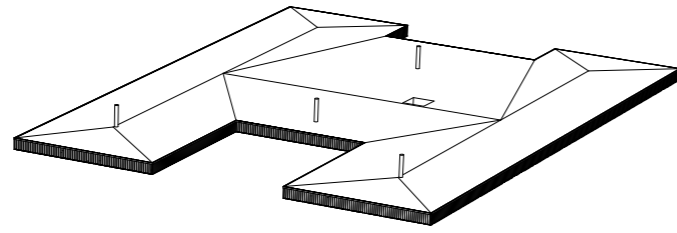

*LVL - beams*

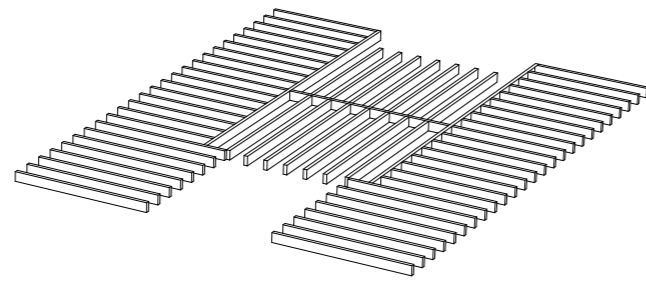

*Load-bearing walls*

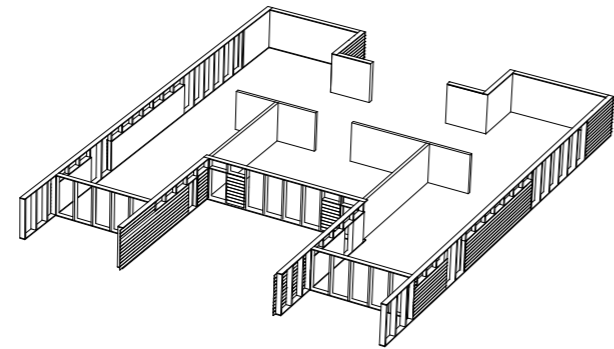

*Floating pontoon*

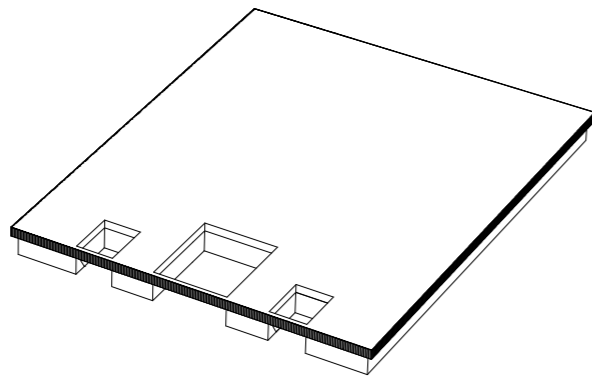

- 1. BITUMEN SHEETING  
22 TONGUE-IN-GROOVE BOARD  
AIRGAP  
WIND PROOFING  
115 X 600 LVL BEAM  
360 INSULATION  
250 VENTILATION AND INSTALLATION SPACE  
13 BOARD  
28 X 70 SPACED BOARDING  
22 x 120
  
- 2. 22 X 220 HORIZONTAL BOARDING, PINE HEARTWOOD, OIL IMPREGNATED  
AIR SPACE  
WIND BARRIER  
45 X 45 LATH, INSULATION  
115 X 180 INSULATED GLUELAM CONSTRUCTION  
VAPOUR BARRIER  
45 X 45 LATH INSTALLATION LAYER  
15 PLYWOOD SHEETING
  
- 3. 25 MASSIVE WOOD FLOORING  
FLOORBOARD  
22 FLOOR CHIPBOARD  
FLOOR HEATING  
8 CONSTRUCTION PLYWOOD  
300 INSULATION  
240 CAST CONCRETE SLAB  
PONTOON

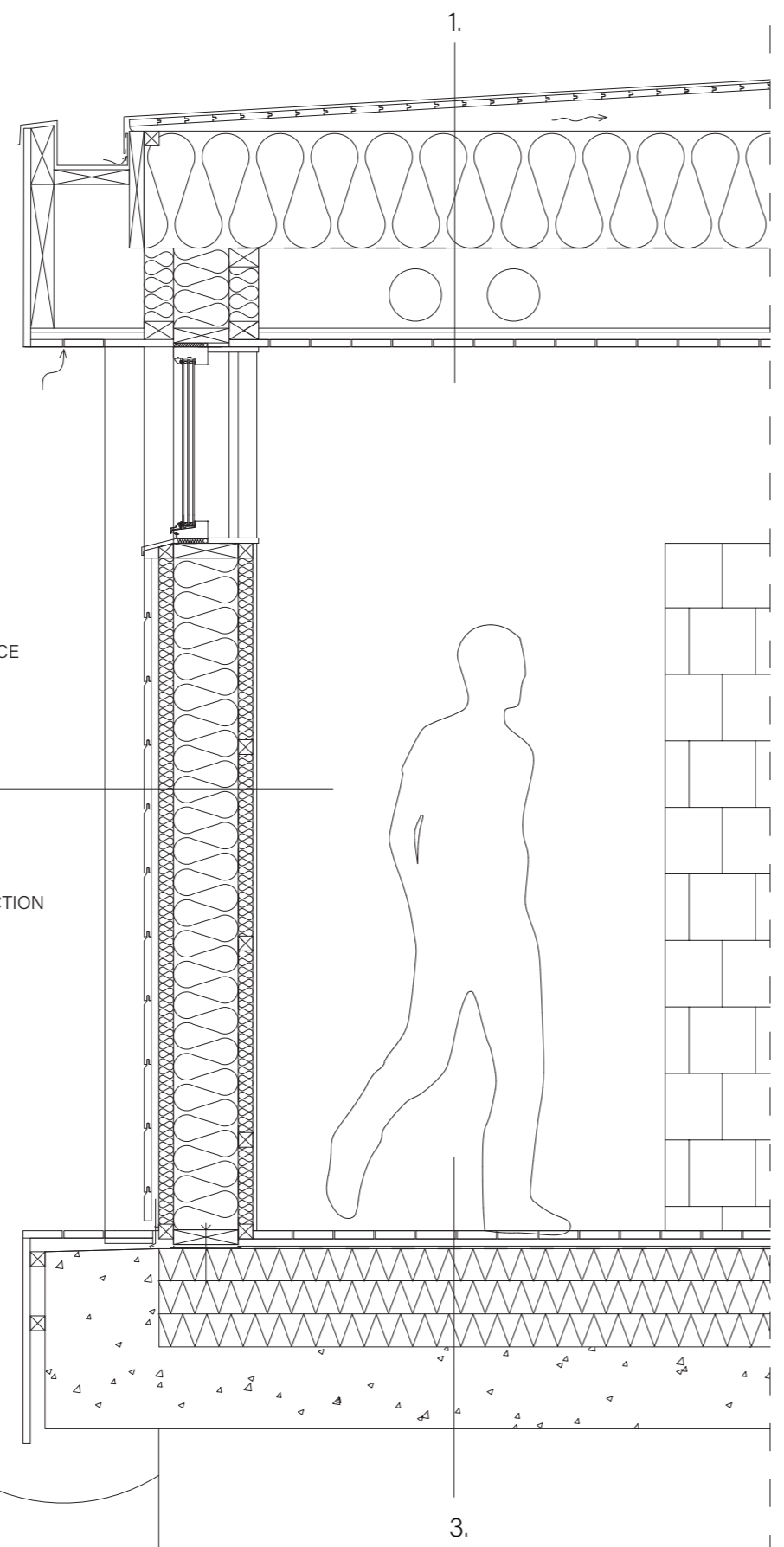

DETAIL SECTION 1:20



ELEVATION 1:20

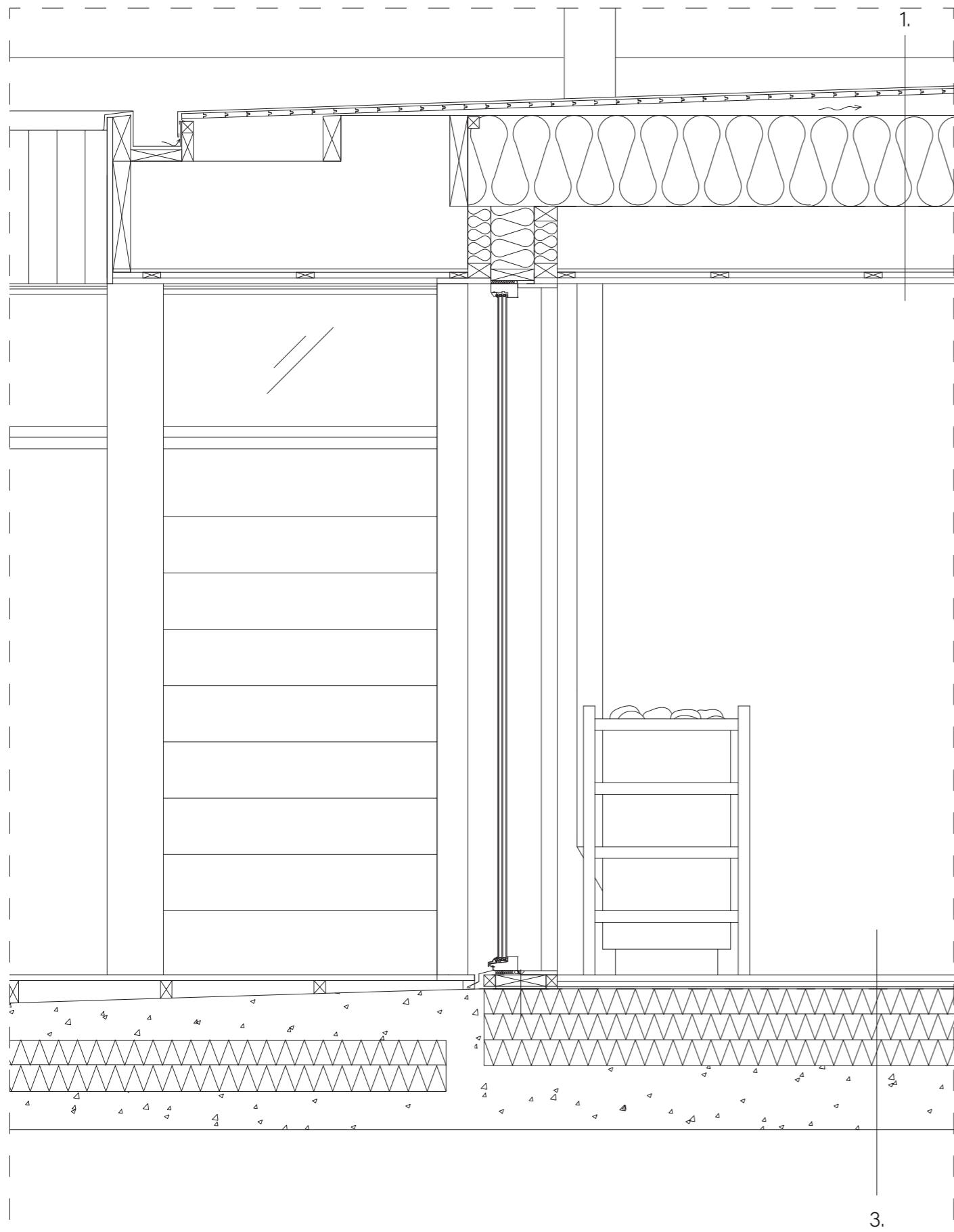

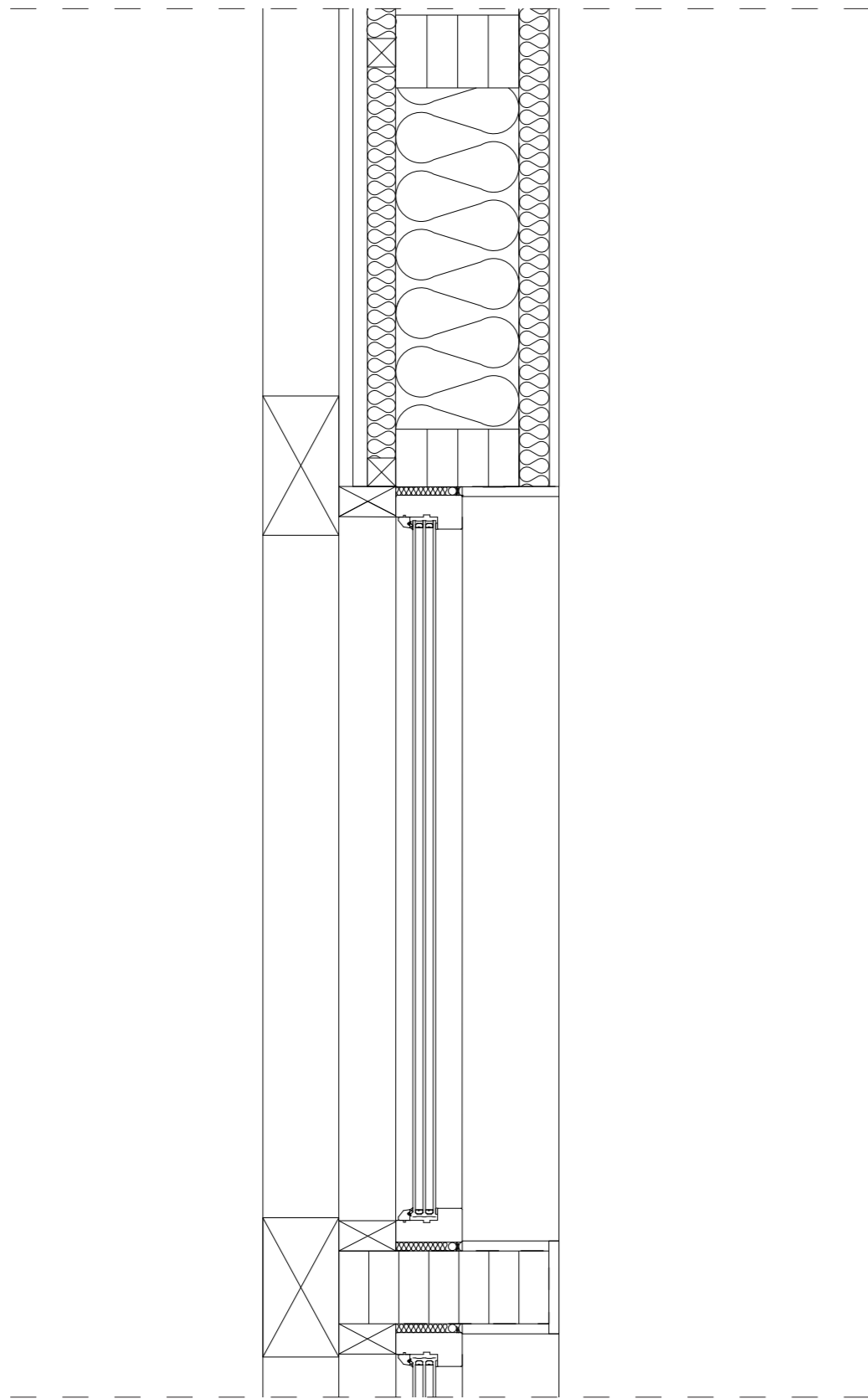

*Wall meets window - horizontal section  
1:10*

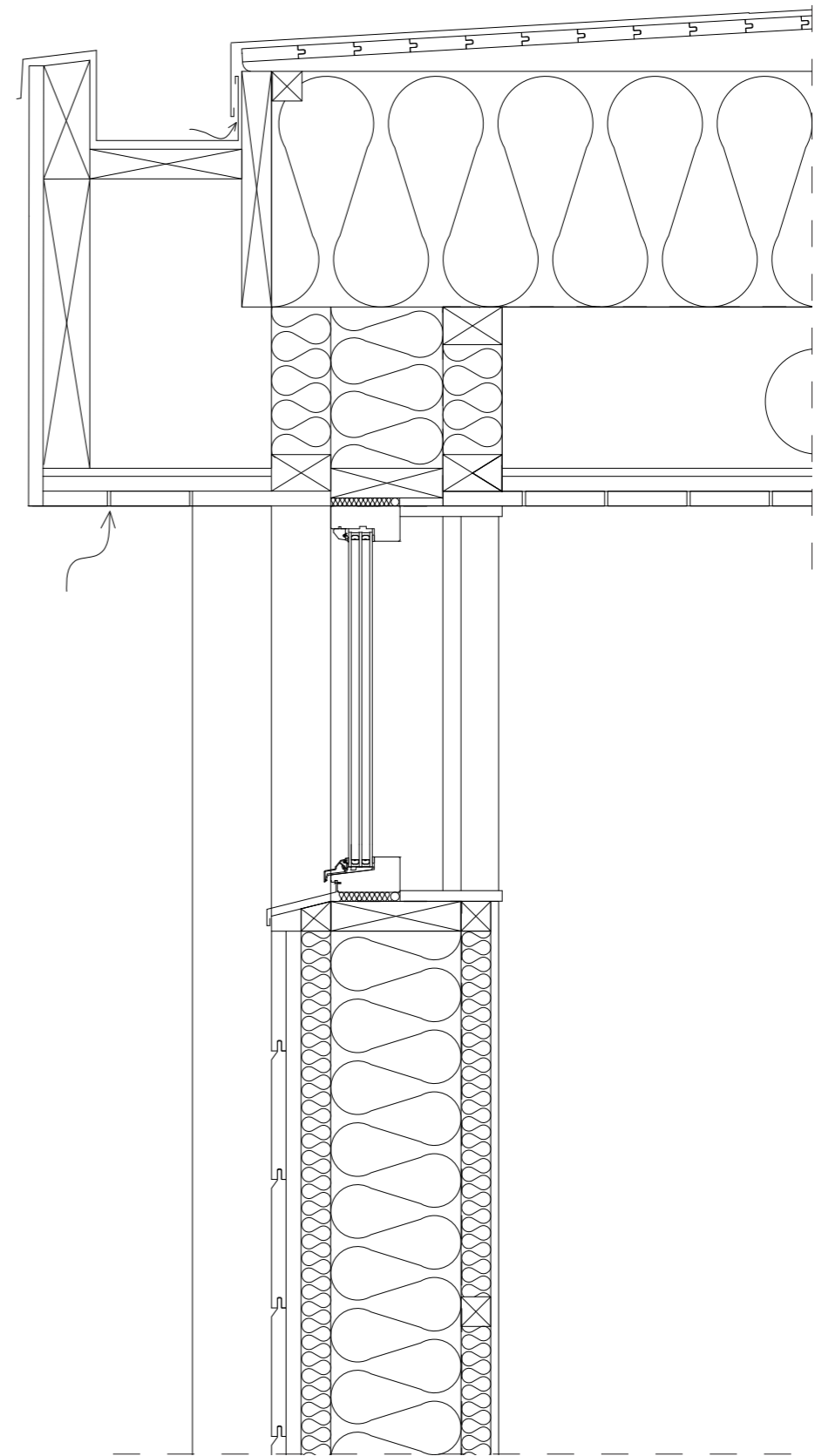

*Wall meets window - vertical section  
1:10*

V

CONCLUSION

## CONCLUSION

The purpose of this thesis was to investigate how architecture can facilitate a stronger connection to a place with the help of Nordic bathing rituals, and I believe that the design of Bölebadet, to at least some extent, deals with the complexity of contradicting notions that define a cold bathing facility. It must be a place that houses spaces that provide both privacy, intimacy, and community.

The three phases of the project, as outlined in my section on the methodology of the work, provided the design with key aspects that proved useful as the project evolved, where both information regarding the site, the history of the sauna bath and the ideas of sensory experiences and love of place became key aspects to consider.

When working with the site, and thereby delving deeper into the history of the log driving era, I came across many important aspects regarding vernacular architecture and how we relate to structures of the past. This part could have been expanded on further, as it is an interesting discussion, however I chose to remain focused on the sauna ritual, as I felt it bore a stronger connection to the program and could therefore be utilized more as a design tool. However, I chose to pay homage to this time period in the design of the façade, and although it is merely one of the many ways in which this era could have been celebrated and portrayed, it is the one I saw most fit for this project.

The plan and layout of the design of this project has been heavily influenced by the references collected in the early stages, as well as various iterations and conversations with friends and tutors, where they have been telling me about their sauna experiences and preferred bathing ritual or sequence. Furthermore, the information gathered on the ritual of sauna bathing in Sweden, both contemporary and historically, was important parts of the framework as they helped set the tone for the outcome of the project.

The design aims to continuously enforce and strengthen the notions of the ritual throughout the building. The flow of the plan is laid out to match that of the ritual, and by for example securing the visual connection to the river throughout the building, emphasizing the connection to the surroundings and presence of nature.

As Barbara Erwine states, and as quoted previously, *“The job of a designer is to orchestrate the sequence of sensory experiences to increase the probability of delight”*. We can never be certain that our intentions become reality, and we can never ensure that people experience a building in a specific way, as we all carry different memories and connotations with us. All we can do is aim to create experiences that enhances the sense of presence in nature, thereby creating stronger connections to the places we visit.



## REFERENCES

### Webpages:

Atelier U20 · Divisare. (n.d.).  
<https://divisare.com/authors/2144828012-atelier-u20>

Badpalatset — AndrénFogelström. (n.d.). AndrénFogelström.  
<https://www.andrenfogelstrom.se/badpalatset>

Bengt Björkman (2022) Västerbotten förr och nu. Älven.  
<https://www.umea.se/download/18.2ebd6da617dd5bf8f744af0/1643189674277/A%C-C%88lven.pdf>.

Flottningen och dess lämningar. Ume Älvdal. (2022, April 27).  
<https://umealvdal.se/besoksomraden/klabbale/flottningen/>

Parken vid Lundåkern. (n.d.). Umeå Kommun.  
<https://www.umea.se/byggaboochmiljo/naturvardparker/parkerochgronomraden/parken-vidlundakern.4.7ce8724f17a0e7e7915125.html>

Strandängens kallbadhus - White Arkitekter Sverige. (2022, July 18). White Arkitekter  
<https://whitearkitekter.com/se/projekt/jonkopings-kallbadhus/>

Parken vid Lundåkern. (n.d.). Umeå Kommun.  
<https://www.umea.se/byggaboochmiljo/naturvardparker/parkerochgronomraden/parken-vidlundakern.4.7ce8724f17a0e7e7915125.html>

Umeå Kommun. (2009). Älvslandskapet i kulturhistoriska drag.  
<https://www.umea.se/download/18.250f9659174ae4b-9794f5c/1601293047652/%C3%84lvlandskapet%20i%20kulturhistoriska%20drag.pdf>.

Umeå kommun. (2020). Bölesholmarna.  
<https://www.umea.se/download/18.19a41f3a17567e789ef-34b2/1605544073180/B%C3%B6lesholmarna%202020-05-07.pdf>.

### Literature

Andersen, M. a. E. (2012). In Conversation: Peter Zumthor and Juhani Pallasmaa. *Architectural Design*, 82(6), 22–25. <https://doi.org/10.1002/ad.1487>

Erwine, B. (2016). *Creating Sensory Spaces: The Architecture of the Invisible* (1st ed.). Routledge.

Frykman, J. (2004). I hetluften. *Svensk bastu som ideologi och praktik. Tio Tvättar Sig*; Pp 87-108 (2004), 87–108.

Heschong, L. (1979). *Thermal Delight in Architecture*. MIT Press.

Pallasmaa, J. (2012). *The eyes of the skin: Architecture and the senses*. Wiley.

Pearson, C. (2020). *The Architecture of Bathing: Body, Landscape, Art*. MIT Press.

Wiell, K. (2018). *Bad mot Lort och Sjukdom : Den privathygieniska utvecklingen i Sverige 1880–1949*. *Uppsala Studies in Economic Studies*, 116. <http://uu.diva-portal.org/smash/record.jsf?pid=diva2:1249611>

## Figures:

Fig.1 Floating bathing facilities, Gustafsberg, before 1910. Lundbäck, M

Fig 2. Bastubad, Bjurbäcken 1911 Keyland, N

Fig 3. Bastubad, Bjurbäcken 1911 Keyland, N

Fig.4 Snow, water and ice, Umeå, 2019. Bergström, K

Fig.5 The dressing zones of Badpalatset. AndrénFogelström. (2020)

Fig.6 Interior view of Badpalatset, Katzenwaffe. (2020)

Fig.7 Strandängens kallbadhus plan, White Arkitekter. (2019).

Fig.8 Strandängens kallbadhus, exterior view Aesthetica Studio. (2019)

Fig. 9 Community centre Spinelli, plan. Atelier U20. (2016)

Fig.10 Community centre Spinelli facade. Wegner. Y (2016)

Fig. 11-13 Google maps (2022)

Fig. 14-15 Lantmäteriet (2023)

Fig. 16 Umeå Älvdal, Kjellberg. K (2023)

Fig. 17 Bölekanalen, Kjellberg. K (2023)

Fig. 18 Vbm SB 2367 - Dammbyggnad, Västerbottens museum

Fig.19 Vbm BR 1549 - Flottning, Västerbottens museum

Fig 20. Vbm C 630 - Älv, Västerbottens museum

Fig. 21 Vbm B 3247 - Damm, Västerbottens museum

Fig. 22 Vbm BR 4956 A - Flottare, Västerbottens museum

Fig. 23 Vbm J 6724 - Flottning, Västerbottens museum



**CHALMERS**  
UNIVERSITY OF TECHNOLOGY