

Beyond Creative Spaces

The cultural centre as a tool for
democratic participation in Ulricehamn

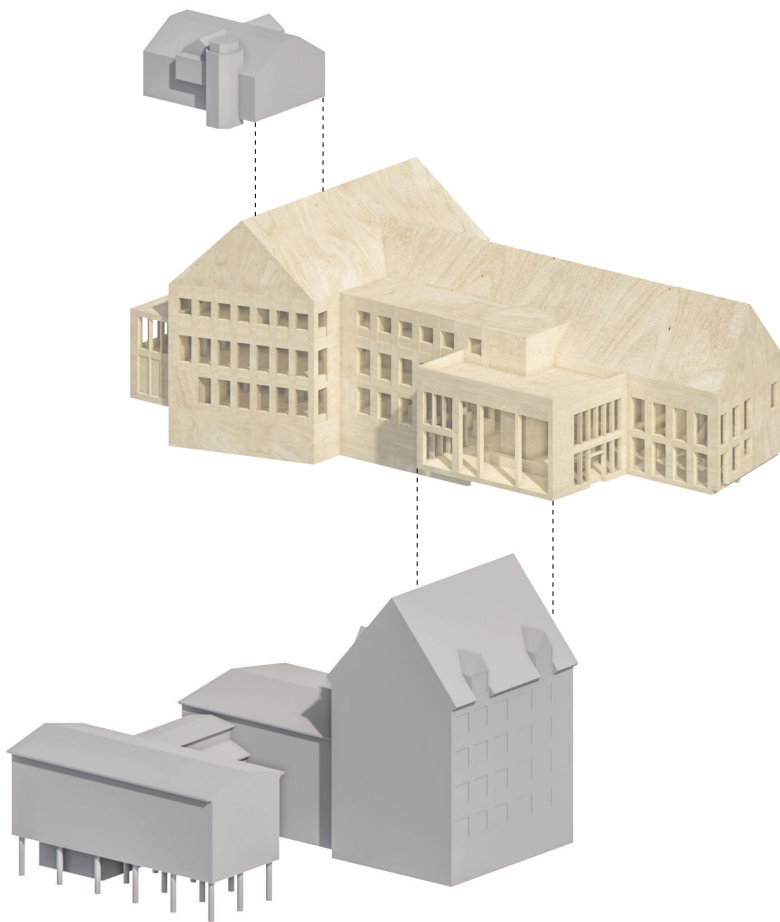

Joel Sidenvik - Master Thesis 2023

BEYOND CREATIVE SPACES

Joel Sidenvik
Master Thesis 2023

Chalmers University of Technology
Department of Architecture and Civil Engineering
Architecture and planning beyond sustainability

Supervisor: John Helmfridsson
Examiner: Nils Björling



CHALMERS
UNIVERSITY OF TECHNOLOGY

Abstract

Culture is changing as people get more accustomed to creating and not only consuming, leading to higher expectations of interactivity and participation. The role of the public, cultural institutions are also changing with the meeting place becoming a more important feature to focus on. At the same time, the need for new democratic arenas is increasing.

The city of Ulricehamn lacks a good, democratic meeting place, which is typically filled by a cultural, public institution. With the small scale of the city, this gives an opportunity to not only create a place that binds together the people, but different institutions and groups with the aim of making the democratic process more accessible with the cultural centre as a tool.

The result of the thesis is both the design of a cultural centre but also a discussion based on this about how architecture can help facilitate the interaction between culture and the democratic process.

The design research explores how to generate low- and high intensity meetings between the inhabitants of Ulricehamn through flexible spaces that house multiple actors in the same venue. The new building integrates with the City Hall and Youth centre to create new connections and means of participating in both culture and the decisions being made about the city.

Design strategies are formulated, based on the analysis, theory and learnings from the design proposal. They focus on creating a third place and integration with the cultural landscape of the city as well as selected actors.

The opportunity of using culture to interact with the democratic process is discussed and the connection between the City Hall and other actors as an opportunity to create something specific to the context of Ulricehamn. The social aspect of culture is seen as an important part in keeping it relevant in a future changing landscape with the cultural centre being a place that can transcend the term third place.

Keywords:

culture meeting place connections democracy youth

Contents

Abstract	3	Building layout	64
Reading instructions	5	A living room for Ulricehamn	68
Introduction	7	Generating meetings	70
Student background	8	Housing the actors	72
Glossary	9	A day in the cultural centre	74
Background & Problem Description	10	Sections	76
Aim & Thesis questions	12	Design principles	78
Expected outcome	12	Discussion	81
Delimitations	13	Discussion	82
Culture	14	Conclusions	86
Meetings	14	Reflections	87
Methods	15	Reference list	90
		Acknowledgements	92
Theories	16		
Investigation	19		
Reference projects	20		
Litterature analysis	24		
Ulricehamn Context	29		
Regional Context	32		
Cultural mapping	34		
Site analysis	40		
Urban analysis	46		
Brief	48		
Design research	53		
Process - applying the investigation	54		
Design Proposal	58		
Context	62		

Reading Instructions

1. Introduction

This chapter introduces the topic of the thesis, the questions asked, and methods chosen for the project. It is the base on which the work was carried out and helps to understand the following chapters.

2. Theories

This chapter describes the theories that are at the base of the project. These are used to inform the work carried out and act as a foundation for the why and how of the work.

3. Investigation

Describes the process of investigation to gain an understanding both of the context of the project but also the important aspects to think about when designing a cultural centre.

4. Design research

This chapter showcases the suggested design implementation that adapts the design principles to the site and creates the centre of a new cultural and democratic cluster. It ends with the design principles that are the culmination of this chapter and the theory.

5. Discussion

A discussion and reflection on the project about the design principles, answering the research questions and reflecting on the process and the project in relation to the situation in Ulricehamn going forwards as well as the many ways in which democracy and culture interact.

All figures are authors own work unless otherwise specified.



Figure 1. A spring day in Ulricehamn.

2023.04.17 15.29



Figure 2. The current city library in Ulricehamn, located in an office building used by the municipality.

2023.04.17 15.35

Introduction

Student background

Glossary

Background & Problem Description

Aim & Thesis Questions

Expected outcome

Delimitations

Culture

Meetings

Methods

P. 7-15

Student background

2017 - 2020 Bachelor's in Architecture and Engineering, Chalmers University

2020 - now Master's in Architecture and Sustainable development

Studios: Local Context
Reality Studio

2021 - 2022 Internships

Gothenburg city planning office
ferrum arkitekter

2022 Exchange semester, Strathclyde University, Glasgow

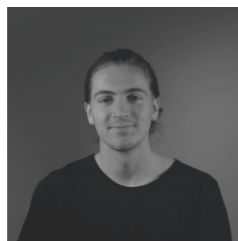

The idea for the Master's thesis came from me wanting to do a project based in my hometown of Ulricehamn. It is a project that applies what I have learned during my studies in a context I know very well.

Glossary

Actors: Groups or institutions that are relevant to the project, for example the youth centre, cultural school and city Hall.

Cultural participation: A situation where people not only absorb culture but put their own skills to work. Writing and not only reading, producing and not only listening to music. (Sacco, 2011)

Gördellist/Våningsband: A horizontal band in a facade either visually separating two stories or places somewhere else not at the top or bottom the building.

Social capital: Trust in a society, both within and between social groups. Higher social capital leads to a more stable society. (Aabø, Audunson, & Vårheim, 2010)

Sockelgesims: A horizontal band in a facade marking the base of the building.

Background & problem description

A need for new democratic arenas

A trend in recent years has been an increasing divide between a political elite and people who don't feel like a part of the process and distant from the places of decisions. Transparency and the possibility of interaction between those in charge and those who feel excluded is becoming more important. (Kulturdepartementet, 2018)

Democracy and the city

The running of the municipality is evaluated in the report *Kommunkompassen Ulricehamns kommun*. An area where Ulricehamn scored higher than the average is the interaction between elected representatives and citizens, particularly in the information channels from the municipality. (Eldås & Carlsson, 2022) As a smaller municipality, the perceived distance between politicians and citizens can feel shorter as there are less people, giving a good foundation for an even stronger participatory process regarding the running of the city and decisions being made.

One of the things mentioned as a possible improvement is to turn the reception at the City Hall into something more like a citizen office which could improve the aspects of "Focus on service" and "Simplified contacts with the municipality" which scored 12/20 and 13/20 respectively. (Eldås & Carlsson, 2022) The reception creates an arena of interaction on the term of the municipality and not the citizen, something which could be improved upon and opened to lower the barrier of participation from the side of the inhabitants.

As the city grows larger, the distance between citizens and politicians can be assumed to grow as the number of elected officials per capita decrease and less people have social connections to people in charge. This could lead to a decrease in direct dialogue between inhabitants and the governing body in favour of other more non-direct modes of interaction (Wide, 2017).



Figure 3. Map of central Ulricehamn 1:5000. A wider map in scale 1:25 000 can be seen in figure 15 on page 30

Decades of planning a new library

A topic of discussion in Ulricehamn is the need for a replacement of the city library, a process that has taken decades and is still ongoing. For a small city, where social connections hold high value, it lacks the important democratic meeting place that an open, cultural institution provides.

Today, the library is housed in an office building (1) which is not situated along any busy street and the entrance is discreet in an otherwise anonymous building. At other places in Ulricehamn there are good cultural spaces such as Folkets hus that are underutilised.

The plans for a new city library began over two decades ago, and there is currently no building permit or set date for completion. The building housing the library today has reportedly suffered leaks and a bad working environment, leading to health issues for the staff. (Erickson, 2021) In 2013, there were news of the collections in the library being put at risk, with important historic documents in danger. (Dahlberg, 2013)

Twenty years ago, there were plans to build a new cultural centre close to the lake (4) with Gert Wingårdh being involved in a design. They were ultimately scrapped by the political opposition for various reasons including that it would cannibalise on the existing cultural centre found in Folkets hus. (Seldevall, *Nytt stadsbibliotek – ett antiklimax för kommunen*, 2023)

There was an ongoing process of designing a new city Library in Ulricehamn planned to be built next to the bus station and ICA supermarket (2). It would primarily have been a library with some other spaces such as a larger black box and exhibition hall, but not enough other functions to be called a cultural centre.

In March of 2023, during the work on this thesis, the politicians of Ulricehamn decided to scrap the plans at ICA, which has to date cost 30 million sek (Seldevall, *Miljonrullning runt stadsbiblioteket men ännu inget bygglov*, 2023). The process going forwards is once again open, with some politicians advocating a new placement on a site called "Marknadsplatsen" (5) and another site up for discussion is "Stureparken" (3). With the process now having to start over, the time until a proper public cultural space stands complete is distant yet again, and Ulricehamn becomes a less favourable option to others as it continues to grow without the cultural arena a city of this size should have to stay competitive.

The thesis focuses on this topic and adds a different perspective on how to solve the cultural need of Ulricehamn in a future-proof and socially centred design.

To enable a strong interaction between the municipality and its citizens as the city grows, the physical meeting place between the two being opened would set a foundation for continued work on this aspect. Culture is a possible method for doing this, as it uses public space in a more participatory and open way.

Sustainability

Social sustainability is at the centre of the project. It focuses on creating an accessible, democratic meeting place that everyone will feel welcome to visit. It additionally works with making the city hall more approachable to the people and actors in the city.

The placement next to existing institutions will allow for them to use the new spaces, decreasing the space needed when multiple actors can co-exist in them.

Aim & Thesis Questions

Aim

The project aims to investigate what qualities a public meeting place needs today and in the future, both through the research of a change in cultural practices, consumption and what a space needs to become accessible. It also explores the future democratic arena needed for a more direct interaction between inhabitants and municipality.

The project will be contextualised in the city of Ulricehamn, using a site-specific intervention that meets the needs and utilises the possibilities of the city to explore these themes.

It aims to explore what a meeting place for the people, institutions and cultural practices of Ulricehamn could be through utilising existing structures together with a new building, connecting them and applying culture as a method to make a participatory democratic arena while adhering to the cultural heritage. The design is used as a method to explore the topic.

Thesis Question

How can the addition of a cultural centre enable stronger connections between public and cultural actors, creating a new, participatory democratic space in the context of Ulricehamn?

Expected outcome

Design principles

The literature research and investigations will result in design principles for the creation of a public living room through the addition of a cultural centre to the context. These will describe the important aspects the project needs to adhere to in order to create a positive development.

Intervention and discussion

From these, a design proposal rooted in the local context will be used as a tool. It showcases how one can adapt the principles to the specific site. The building created will be a cultural centre with a library and café at the core, surrounded by other cultural functions that bind together the new centre with the existing institutions while allowing for a broad spectrum of meetings to take place. This is then used to discuss and showcase how connections between the municipality, culture and inhabitants can create a new participatory democratic arena.

Sub-Questions

How does a cultural centre remain relevant in the future, with a constantly changing cultural landscape?

How can the cultural centre act as a third place in the city of Ulricehamn?

Delimitations

The building design is not seen as a final proposal, but a tool for discussing the topic.

Creating a sufficient amount of parking space next to the building based on what needs it would create is not part of the project.

A selected few actors were chosen for the project. Other private cultural ones in Ulricehamn were not included due to a lack of time.

The intervention does not adhere to the current detail plan for the chosen site.

Design of technical spaces in the building are not taken into account.

The economics of the design is not discussed as it is intended as a tool for discussing the topic rather than a final proposal.



Figure 4. View of main square from side of Bogesundsgatan. Photo by Jan Töve, retrieved from: <https://www.ulricehamn.se/uppleva/sevarda-byggnader/>

Culture

The term culture is central to the thesis topic. It can mean different things and to better grasp the discourse, one must understand what definitions are applied in the project. The one found in the dictionary would be:

"the customary beliefs, social forms, and material traits of a racial, religious, or social group. Also: the characteristic features of everyday existence (such as diversions or a way of life) shared by people in a place or time." (merriam-webster, n.a)

Rather than this broader term, the project focuses on what would be described as part of the public culture; libraries, art, theatre, culture schools and other actors involving the inhabitants of a community. These can be both professional, working with culture or amateur that create during spare time. The actors are divided between public and non-public institutions, organisations and groups. These actors in the context of Ulricehamn are discussed in the investigation chapter, giving an overview of those included in the process.

The project looks at the connections between these and how to bring them together through a new architectural development, creating a democratic meeting place.

Additionally, there is a dimension of the cultural landscape which is described in the theory and investigation chapters.

Meetings

Meetings happen on various levels of interactions and participation. It can be categorised into two parts: low- and high-intensity meetings.

The high-intensity ones are often centred around a mutual interest or activity, examples being at work, social gatherings, taking part in a club or other activity. These are more direct interactions, often with people that are part of the same group.

Low-intensity meetings are more non-direct, existing through being exposed to people from other backgrounds and with different interests that one would not meet through chosen high-intensity situations.

Both types are important for society as they allow people to feel a part of something larger and understand those from different social groups. (Audunson, 2005)

A meeting can take place between people, cultures, actors, different groups, buildings and others. When the term meeting place is used in the project, it is not only suggesting a space for interaction between individual people but also groups, actors, politicians and the various layers of the city.

Methods

The thesis worked with research by design as a framework, with the process and final design of the building used to answer the thesis questions and the architectural investigation being a part of the research methodology.

Literature studies were used to support the theories of the project and an analysis on their application.

Interviews with architects were carried out discussing the design of cultural spaces.

Cultural mapping as a method is described in "Creative Towns and Regions handbook" by Lia Ghilardi. There are five tools described as part of the mapping, which of I used parts of two: Desk research as well as Qualitative Cultural & Creative Resources mapping. These include basic mapping of the place, creative networks, assessing infrastructure and actors.

Further, the methodology describes how to work on the groundwork for a cultural intervention through holistically understanding the Urban and Cultural DNA of a place which is done through cooperation between municipal bodies, local actors both from the public and private sectors as well as building up the capacity of the context through involving the local stakeholders. (Ghilardi, 2017)

Cultural mapping was carried out to understand the cultural context of Ulricehamn.

Theory	Literature studies were carried out to create a framework for the project.
Investigation	The Investigation has three different parts with accompanying methods:
Building analysis	A look at existing cultural centres was carried out through site-visits, literature studies and interviews with architects.
Context analysis	The Ulricehamn context was researched through literature studies, the actors using cultural mapping and the site through spatial analysis.
Design principles	The findings of the theory and investigation were translated into design principles that summarise the findings and how they could be translated into a building.
Design research	The intervention was based on the spatial analysis, brief and investigations. It was created through an iterative process as the design got informed further through the other methods and used as a tool to discuss the topic.
Discussion	The project was summarised and reflected upon with a discussion on the themes of the project and how the intervention responds to the research question, theory and investigation.

Theories

Cultural landscapes

The cultural landscape is by described as a fifth dimension to our space and is another aspect to be understood in order to make qualified interventions. It is the many ways a place is described and remembered both through the physical space but also intangible memories. (Mellano, 2017)

Intervening in the cultural landscape does not mean to camouflage or completely subdue to the existing hierarchy and style. It is about making additions and changes to the status quo, while still referring to the specificity of the place. (Mellano, 2017)

Culture 3.0

The cultural age we have entered is described as culture 3.0. It is defined by a erasure of the distinction between the creators and consumers of culture. Today, it is cheaper and easier to create as well as showcase it to others via digital channels, creating a much larger accessibility to the medium than before. This generates a higher knowledge and therefore a consumer base that has different expectations than earlier generations. In the age of culture 3.0, a higher level of desired participation and influence on institutions can be expected, making culture more democratic. (Sacco, 2011)

An effect of this participation in culture documented in youth is how it influences their world view. A higher percentage of youth with a "cultural identity" see a multicultural Sweden as enriching, have higher trust and more interest in societal topics. Many can see an increase in self-confidence, health and school results through participating in and creating culture. (Bergquist, 2012)

Third places

Third place is a term used by sociologist Ray Oldenburg. First place describes one's home, second place one's work and third place is a social meeting place, one that anchors a person to their community, providing more creative and informal communication. (Sleeman, 2012) It is a homely place away from home defined by reducing differences and creating social equality, contributing to a more democratic society. Oldenburg described eight characteristics of a true third place:

1. It is a neutral space.
2. A place which contributes to social justice, where status or money does not matter or affect the use of the place.
3. Conversation is the primary activity of the place.
4. It is accessible for everyone and is available for people when they need it, having generous opening hours and responds to the needs of the people using it.
5. There are regulars who help the place feel lively and attract in new people.
6. It keeps a low profile and does not feel pretentious or excluding.
7. The setting is more informal and playful, and the place is kept lively since people want to go there again.
8. Is a home outside of the home, where people can feel belonging and connection (Istenes & Larsson, 2011)



Figure 5. Folkets hus, an important part of the cultural landscape in Ulricehamn.

23.04.17 15.41



Figure 6. Ulricehamn City Hall. A distinct building at the site of the project, as seen from the northeast.

2023.02.10 12.10

Investigation

Reference projects

Literature analysis

Ulricehamn context

Regional context

Cultural mapping

Site analysis

Urban analysis

Brief

P. 19-51

Reference projects

Learning from cultural spaces

As a part of the investigation, several cultural centres were visited and researched to gain an understanding of what has been done well and what to avoid in this project. Interviews with several architects who had been part of designing some of these projects were also carried out.



Figure 7. Floor plan of Kulturhuset Bergsjön with the restaurant at the top and library below. The door connecting them is not in use and passage must be made outside. Plan by Sweco (2020), retrieved from the Gothenburg city planning office.

Kulturhuset Bergsjön - Gothenburg

A new cultural centre for the district of Bergsjön finished in 2022. It houses a library, restaurant, exhibition space and creative studios. At the centre of the building is an open atrium, creating a movement around it while allowing for overview between spaces.

The project works well with sight within the building, creating a space where the staff can easily see what is happening as well as the visitors getting an overview of what is on offer. To allow for maximum manageability for the staff, there are desks on both floors, so they do not have to go between the different levels to check.

The library houses a room where one can meet with government agencies, enabling a more accessible space for interaction. This would be interesting to take further and integrate more in the project.

One thing that has not worked is the integration of the restaurant and the rest of the building. They are separated by a glass wall, which is a problem because the door between them is not in use. To go between, one had to first exit the building and then go back in through a different entrance, creating a strong sense of separation.

For a café/restaurant to work better, it must be integrated in the space and run by the municipality.

Having reception desks on multiple levels creates easier overview and more possible active spaces.

The cultural centre can become a more accessible space to meet agencies and municipal functions, lowering the barrier of democratic participation.

Selma Lagerlöfs Center - Gothenburg

Finished in 2019, the project was a new cultural centre for the district of Backa in Gothenburg. It houses a library, restaurant, municipal offices and spaces for meetings as well as artistic creation and expression.

There is a central atrium that connects the spaces of the building. Because of its size, it creates a barrier separating the functions instead of forming a unity. The atrium connects them visually, but also becomes a spatial border as the main activities of the building do not occur in what could have been the busiest space in the centre.

The library in the building is small and dense with little space to sit and read or socialise. It would have been interesting if it could have extended into the open atrium to create a more open and spacious feel while adding liveliness.

According to the lead architect of the project, they worked with flexible rooms that can be used by groups at different times of the day to minimize the need for space. The atrium was also planned to make sure one sees people when entering. If the space is empty, it would not be inviting. (Lind, 2023)

Compared to Kulturhuset Bergsjön, Selma is much bigger. There is significantly more office area in Selma, as well as the cultural school being housed there which requires more space. They also have a bigger stage area, and these are all fully fledged facilities, while at Bergsjön it is more based on the library with smaller functions added around it.

If the library had been in the central space with some of the other functions having other possible entrances as well, the atrium would have felt more alive and welcoming.

Flexibility of spaces is important to keep building size to a minimum.

The space between functions needs to be active or it becomes a barrier.

The people should be in the spaces one sees when entering. If they are empty they are not inviting.

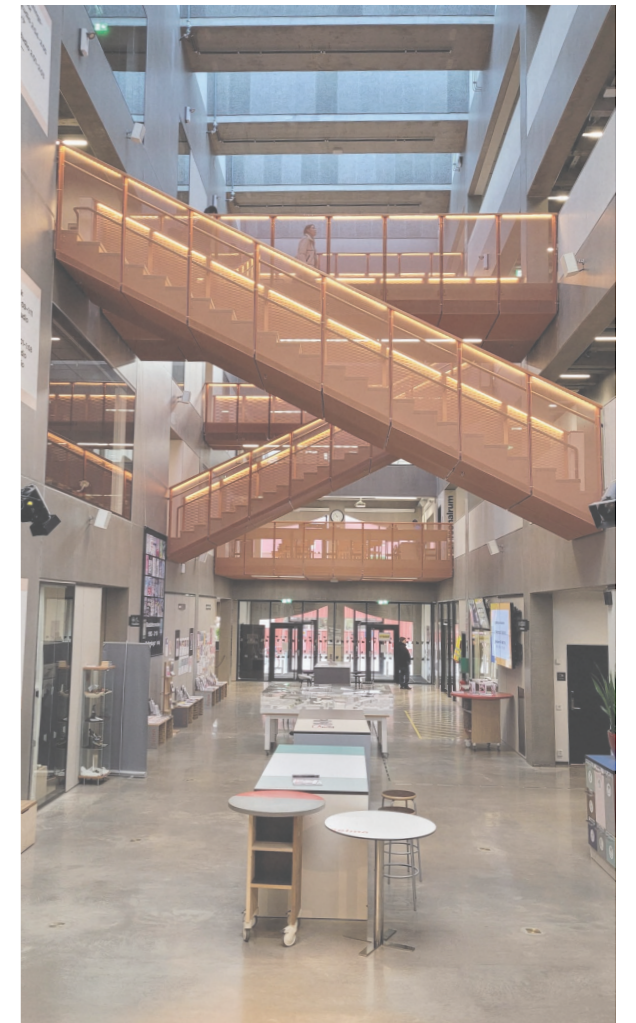

Figure 8. Central atrium of the building.

23.01.27 14.49



Figure 9. The library at Käken. 23.01.26 10.28

Käken - Gothenburg

A library with a café and an assembly hall in Källtorp, Gothenburg. The entrance to the building is discreet from the outside, and from the inside one does not get a good overview of the building. There is an open space with seating on the lower level disconnected from the library above which makes it feel like disconnected.

The building is long and narrow with both entrances located on the same side. This creates a dead end at one side of the building and with how densely the bookshelves are placed, as seen in figure 9, little sense of space is found.

An elongated building volume needs multiple movement paths and different entrance spaces to create a more balanced layout.



Figure 10. Child section of library, Vindeln. Photo by Leandersson, retrieved from: <https://magasink.se/2022/09/folkbibliotekens-olika-rum-fran-skrytbyggen-till-ombyggda-butiker/>

City library - Vindeln

Opened in 2001 next to the local school, the library was to become a meeting place between the youth and city. Having it completely open between the institutions during school hours created a lot of noise and disturbance, and some people stopped coming during this time of day. Now it has been closed off between the two and the strong connection that could have been is no longer there. (Hallemar, 2022)

The square between is now purely a part of the library and the balcony looking down upon the school was closed due to problems with order. (Hallemar, 2022)

It is important to consider how to manage noise and disturbance to the rest of the space when connecting to an actor with children and/or youth so that other groups feel welcome.

BIBLIOTEKET - Nordvest, Copenhagen

A cultural centre in Copenhagen which was completed in 2011. The old building was complemented with new additions which allowed for half of the existing area to be used as space for a youth house which had been left without a building since before. In addition to housing a library, creative studios and a performance space it has a civic centre.

Architecturally, the building is meant to symbolise a stack of books, with each block being a different function. (Cobe, n.d.) This shape with the golden facade makes for a striking addition to the cityscape, a new node. The more interesting part is the interior between the new and old.

The space between the existing building and the new creates an interior street as seen in figure 11, connecting the functions of the building and directing towards the youth house.

This project was the first combined library and cultural centre in Denmark (dac, n.d.) and creates a social hub for the area. Even with the youth house being a separate function, the collection of it, the library, cultural functions and civic centre creates an area with a plethora of activities and a means to create an improved social climate.

Using different volumes for functions can make the building feel like one whole while also showcasing that there are multiple things on offer.

Placing the entrance in between the old and new allows for interesting spatial qualities.

Collecting the youth house, cultural centre and civic centre in one area gives the opportunity to create a third place and democratic arena.

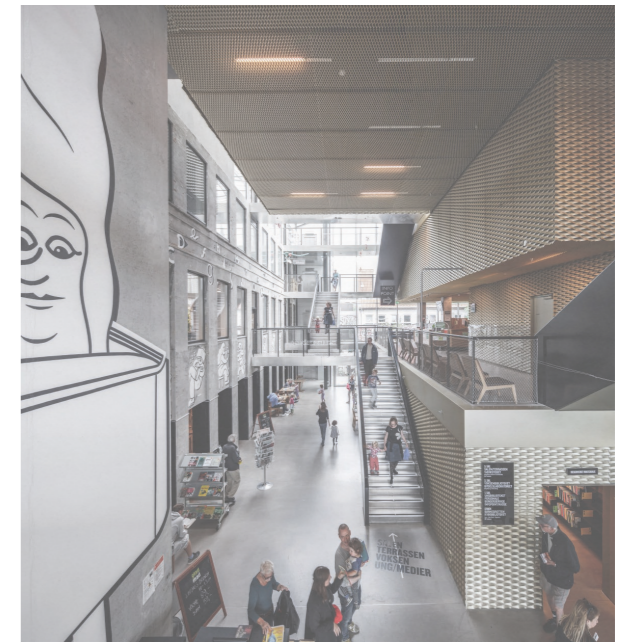

Figure 11. Atrium between existing and added parts. Photo by Hjortshøj, retrieved from: <https://dac.dk/en/knowledgebase/architecture/biblioteket-remestervej-2/>

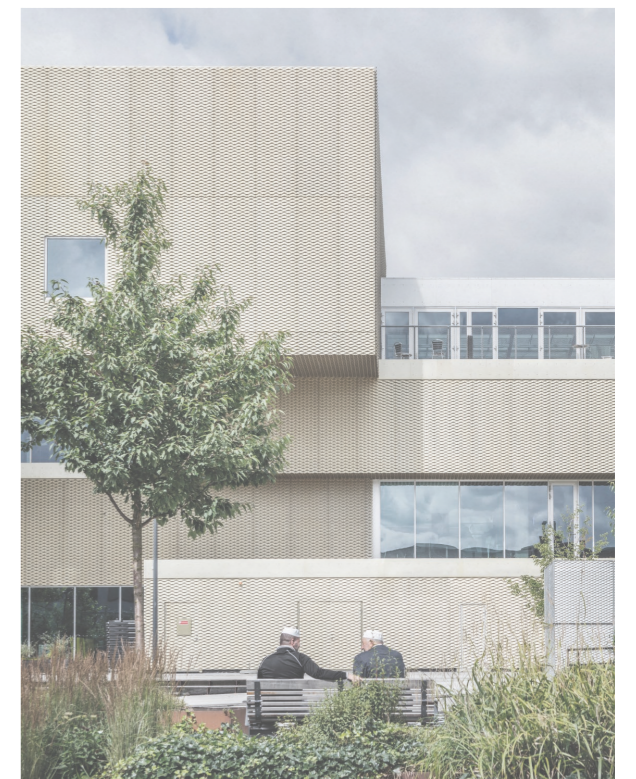

Figure 12. Volume with blocks indicating different functions. Photo by Hjortshøj, retrieved from: <https://dac.dk/en/knowledgebase/architecture/biblioteket-remestervej-2/>

Literature analysis

A changing cultural landscape

The report "Är framtiden kulturens re-renässans" shows that a large majority of Swedish youth (13-25 years of age) are culturally active during their spare time. The activities range from writing, music producing, painting and partaking in organised cultural forms. (Bergquist, 2012) This new consumer group in culture 3.0 will look for places that enable interaction. Therefore, the public spaces need to adapt and create meeting places that includes all level of desired participation (Bergquist, 2012). With the positive effects documented on youth by cultural participation, the interactive aspect of new projects should be prioritised.

Enabling the cultural participation not only strengthens the cultural sector, but others as well. Higher levels of innovation and entrepreneurship can be seen with cultural creation as the top countries in cultural participation in the EU are also at the top of the innovation index. Higher levels of cultural participation could lead to more innovation and therefore a boost to the prospects of a place (Sacco, 2011) Add to this an easier link between different actors and the municipality, and it can be a part of a change that strengthens larger parts of a society.

Cultural spaces allow people to raise questions other public institution do not want to discuss. Through art and creation, topics such as sustainability and multiculturalism becomes easier to grasp and to talk about. Spaces exhibiting knowledge become especially important as they allow for greater understanding (Bergquist, 2012). This becomes an important democratic instrument, in generating a stronger and more inclusive and accessible public debate.

Lessons from the Pandemic

An important aspect of the public, physical spaces for culture in the future will be the democratic one. Culture became more accessible during the covid-pandemic, with a much broader material available via the internet to new audiences and in new ways. The amount of cultural participation did not change greatly and the audience for specific mediums such as art and theatre were the same as when they were physical according to a study made in England (Tal Federa, 2021). Groups that already engaged in cultural activities saw an increase while groups with larger barriers saw lower levels of participation than before.

The divide between groups increased during the pandemic with ethnic groups, disabled and those with lower education decreasing and higher occupations and people with academic degrees increasing their consumption. This shows that the digital culture can be used to reach more groups in new ways, while physical spaces are important for those groups that traditionally have a lower interaction with cultural content. (Tal Federa, 2021)

In today's cultural landscape, people are getting more used to creating culture and not simply consuming it, especially youth. There is a possibility of offering more and better spaces for participation, strengthening the creation of culture in the city and building new arenas for people to express their thoughts and ideas.

With a connection to the city hall, the living room can become a place where a more accessible and inclusive debate can be directly accessed and taken part in by the people in charge.

Future spaces for culture

In the report, "Framtidens Kulturlokaler", the demands placed on cultural arenas and what they must offer is discussed. It is made as a guide and inspiration for future developments.

In many cases, the library is the public cultural institution available in the municipality and must act as the non-commercial meeting place of the town or city. This is something many library spaces are not suited for and one thing to keep in mind when designing new ones. Cultural centres are found in 95 of Swedish municipalities, whereas 72 are public and the rest managed privately or by local organisations. They are primarily spaces for hosting multiple forms of culture such as music, theatre, film etc, and only a small part of them are used for allowing citizens to create themselves. (Wiksfors, 2019)

An aspect lifted by Kjellberg (2019) is that of a shared usage of spaces. This is discussed in relation to the lack of spaces seen in Gothenburg and finding a way to accommodate the increasing need for them. Many spaces are seen as being underutilised at the same time as the need is rising. A use of them for multiple activities might therefore become more common in the future and affect the cultural practice as the spaces offered might not properly accommodate the needs of the cultural inhabitants.

The role of the library as a place is shifting, with the current debate focused more on the space as a centre of experiences. Activities should be available including workshops, theatre performances and gathering. (Istenes & Larsson, 2011) Spaces should be generic enough to handle the specifics for each activity and flexible enough to change in the future without losing architectural qualities.

In addition to the content, the location is central to how the space will be inhabited. For a building to attract enough people to maintain the activities, one needs to understand how people move in the city and place it so that it is easily accessed from main routes. (Wiksfors, 2019)

The brief of the building should create a space where professionals in the cultural sector get a scene to be exposed to the audience which is becoming more important in a digital cultural landscape where that link becomes weaker, as well as creating spaces for the interaction and possible personal development of the general public. (Wiksfors, 2019)

For the spaces to be relevant in the future, flexibility is important. This becomes central in the building being able to inhabit multiple functions and actors, not only the cultural ones.

Below: Figure 13. The same space should enable different uses by various actors.

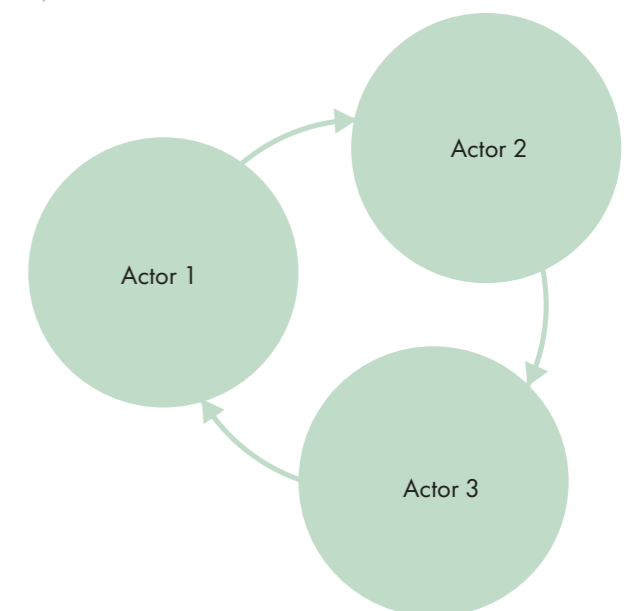

The library as a third place

When looking at a traditional library, there are a few of the characteristics of a third place that are not fully realised. Conversation is often not the main activity, in many cases because of the perceived requirement of silence. The low profile is also not typical for a city library or cultural centre, being larger in scale. Smaller libraries, however, can meet this. The most distant one is the playful and lively mood, which is often perceived as opposite of the library. (Ingvarsson & kulju, 2010) For the library to become a part of the living room of Ulricehamn, these would be the main things to work with for it to feel open, inviting and modest.

The library café as a meeting place

The café is one space which has these qualities missing from the main part of the library, being a place of discussion, noise and less requirements. It is a place where you meet other visitors, study or read. (Istenes & Larsson, 2011) For the library to utilise the more relaxed mood that can come from this function is interesting.

A study of the library café as a meeting place shows that many spend time there without buying anything, that the discussion they have with café staff is often not only about the purchase and that many visit the library to spend time there without borrowing any books. (Istenes & Larsson, 2011) The library becomes an important third place for people with little other social interactions, as said by a librarian taking part in the study:

"As a meeting place i don't think it needs to be quiet, as a meeting place cannot be so when there are people living in silence and go here for that very reason" (Istenes & Larsson, 2011, p.26)

The rest of the library can see benefits from the café, with people using it additionally using the library functions and vice versa (Istenes & Larsson, 2011) Add to that exhibition space in the same living room, and synergy effects could lead to a lively and inhabited space.

No matter if integrated or cut of from the rest of the library, a café can challenge the traditional view of it. The challenge lies in the opposite expectations people can have of the liveliness. (Istenes & Larsson, 2011) When separated, the library becomes quiet and possibly stale, while the café becomes too loud for some people. By combining them into the same space, something in between might be achieved. A space that is both lively and silent in different parts, where the library becomes more approachable but not messy. The challenge is to find a balance, where people with different expectations can use the same space. Otherwise, it will not become a space for everyone.

These are qualities that describe a good meeting place for a community and can therefore be used as a guidance for the creation of a public living room and what qualities might need to be added to that of a typical library for it to function even stronger as a meeting place.

The synergy between the library and the café is something often lacking and a better integration between these can lead to a space which can truly become the living room of the city, a third place.

High- and low intense arenas of participation

High-intense arenas of participation are described as spaces where one can find a more homogeneous group of people when looking at age, interests or background such as the school, choir, workplace or sports practice. They are spaces where people go with a more likeminded intention, and these are important for the social fabric of a community while at the same time creating barriers. High-intense meeting occur in these spaces.

The low-intense arenas are the places where one is exposed to people of different social and economic groups and that creating meetings which would not happen in a high-intense one. An example of this is the public library, where people go with various intentions but co-exist in the same space, enabling low-intense meetings. (Audunson, 2005)

The two typologies of high-intensity and low intensity arenas are both described as important for society and the individual. The high-intense meetings which often surround interests and chosen activities are important for a person through creating meaning while being integral for a democratic society by making involved citizens. People who feel like a part of community will see a lower risk of being isolated and creating gaps between social groups.

The low-intense aspect of being exposed to people which one does not usually meet is also important on a societal level by generating connections between different people and social capital through the foundation of trust in others. One concrete example of this brought up was from a public library in Oslo where an internet learning group for elderly and IT-interested youth took part in activities parallel to each other. After some time, these began to interact and the

youth became instructors for the elderly leading to barriers between the two starting to break down (Audunson, 2005)

It has additionally been shown that a large part of people spending time in a public library have accidentally come into a social exchange with people they didn't know, in addition to talking to people of their own social network. (Aabø, Audunson, & Vårheim, 2010)

Other third places than the library risk isolating groups as they can be focused on religion or activity often engaged in by a particular age group, therefore not being low-intense arenas. When these crowds are separated, exposition and visibility lessen, and groups become invisible to one another. (Audunson, 2005) In the library and particularly the cultural centre, these groups can co-inhabit a space and through that start to understand one another and build bridges. This is a process which needs time and through the design it will therefore be important to not force groups together nor separate them completely, to allow the building to facilitate both high- and low intense meetings.

An important societal aspect of the public library is as a low-intense arena of participation where people from different groups encounter one another.

Meeting-places isolated from others and focused on single groups or interests risk creating more barriers in a community, and bringing them together can therefore create low-intense meetings.

Local Cultural Heritage

Preserving tangible and intangible memories from earlier generations is a part of honouring the cultural landscape and identity of the local context. (Bergquist, 2012) An intervention does not need to fully adjust to the cultural landscape but talk to that past world of memories. Referring to the history in a modern context allows an intervention to be a part of the landscape as a new phase. (Mellano, 2017)

Revitalising a local culture

One of the best understood actions for cultural production and usage is that of placing new, public spaces for the purpose of redefining the foundations of the place. Creating new ways for inspiration and the production of new cultural content is a potent tool in the rebuilding or redefining of a local identity. (Sacco, 2011, p.15)

For this reason, it is important that new cultural projects gravitate towards the production of and participation in new culture. From this, new skills and competencies can be built that stay in and continue to curate the culture of the community. (Sacco, 2011)

In "The cultural role of architecture", Nicholas Temple talks about the belief found in many politicians that one can create culture without looking at the existing traditions or institutions. An act that only requires capital and well thought through marketing. He also lifts the increased parallel with culture and capital, that new investments must be justified, instead of simply serving as an enrichment of our common historical memory and existing strengths. (Temple, 2012)

An important part of how culture has been shaped by a more globalised society is that of generalisation and loss of the uniqueness of the local. (Temple, 2012)

Culture can be a tool for a city to help strengthen a local identity, but it has risks. There is a difference between adding new while lifting and strengthening what is already there to create a stronger identity and simply rebranding the place with new impressive projects that as a result leave behind the old structures and actors. (Temple, 2012)

"Culture-led revitalisation strategies have, indeed, often focused on civic image-building and inter-urban competition at the expense of support for local cultural infrastructures and resources. . . . they run the risk of overlooking the indigenous cultural production and training infrastructure, and of fragmenting local social and political cohesion." (European Task Force on Culture and Development, 1997, p.93)

When creating these new spaces, it is important to showcase the bond between architecture and cultural practice. Architecture is a tool for creating culture and part of strengthening it in a city while at the same time, the culture is the basis for what the architecture is being contextualised in and judged through. As with the culture in General, Temple argues that the best way forward is to use and reinterpret that which already exists while creating new networks and relationships. (Temple, 2012)

There is a balance when adhering to the cultural heritage. To not be bound by history while creating something which speaks to the surroundings and connects them to the modern day.

It is important to use and strengthen existing actors when adding something new. One cannot create culture from scratch and there is a risk of weakening the existing when creating a new development.

Ulricehamn Context

Founded at trade route

The first written mention of Bogesund is from 1307, as part of a description of battles between Sweden and Denmark. A marketplace was established where the river Åtran ran out into the lake Åsunden. A settlement grew around this, centred around a trade passage which is where the street "storgatan" is located today. Due to the location close to the border of Denmark, the town both prospered from trade and got burned down several times, which contributed to the historically slow growth. (Ohlsson, 2022)

The golden age

The train came to the city during the 1870s and ran from Ulricehamn to Vartofta. From this, the spa city of Ulricehamn grew forth. The first sanatorium was built, and the city offered clean water, large recreational areas and fresh air. In 1909, the winter sanatorium was completed, and it was said to be northern Europe's largest wooden building. This age lasted until the 1980s when the building was finally torn down (Ohlsson, 2022). Remnants of this time can be found on Nygatan, with its extravagant wooden architecture being an important part of the cultural landscape of the city.

Today

Ulricehamn is a small city in western Sweden with around 25 000 inhabitants in the municipality (Ulricehamns Kommun, n.d). The city is located at the northern end of Åsunden, a lake that has shaped its development. It is around 100 km from Göteborg and rests between the larger cities of Jönköping and Borås.

Demographics

Many in younger ages move away after finishing the gymnasium to pursue higher studies elsewhere, creating a negative flow of people in the ages 18-24. The largest increase in people can be seen in the ages around 0-9 and 30-36. (Ohshima, 2021)



Figure 14. Location of Ulricehamn in southwest Sweden. The dashed line represents the historical border to Denmark and the orange lines the rail network which the city is not connected to. The map is based on data from Holl (2005) & Trafikverket.se (n.d.)



Figure 15. 1:25 000 map of Ulricehamn. The highway (B) passes by the city to the north, further away from the centre than the old road (C). The north-south access to the city is by way of road 157 (A) which passes through the city. The dashed square marks the area of the 1.5000 Map on the next page.

Third places in Ulricehamn

There are spaces in Ulricehamn that would classify as third places and some that partially do so, here is a mapping of these in the city. First, ones that could be seen as true third places:

1. Youth centre
2. Church Hall (and other religious spaces)
3. Oasen - senior meeting place

Some of them share some characteristics to those of a third place, but either lack the focus on meetings or are centred around purchase:

4. Current city library
5. Cafés and restaurants (dots without numbers)

It is valuable to have several third places with different focal points in a city. The missing aspect in the city would be the true third place which is not connected to age, religion or another primary group. This is what the project intends to fill with the cultural centre. The aim is not to replace the existing third places, but rather enrich the social network of the city through more options and places to meet.

In addition to these, there are places in the city that generate low-intense meetings. For children and youth, such places are the schools, youth centre and sports clubs. More general ones can include supermarkets, and the third places listed above. These are spaces mostly centred around specific age groups, activities, or purchase. The cultural centre can add the low-intensity meeting place with no demands which the city is lacking.



Figure 16. Scale 1:5000 map of central Ulricehamn showcasing third places in the city.

Regional Context

A city in growth

Unlike some other smaller municipalities, Ulricehamn is seeing a positive development with an increasing population which is expected to continue growing in the foreseeable future. The growth from the 1970s to modern day and expected growth until 2030 can be seen in the graph below.

A risk when the city expands rapidly is that it loses sight of its unique values in favour of projects that will attract new residents. Ulricehamn has historically seen a slow growth and today it is expanding at a higher pace. This can be seen throughout the city as dense and tall new developments are emerging in many places and the city is changing its character to accommodate as many people as possible. An example is the new centre with an ICA supermarket and additional stores which opened to the north of the city as the highway moved the traffic further out. This shifted the centrality of the city and risks damaging the central actors of the city, leading to a more disconnected Ulricehamn.

In the strive to be a bigger city, it is important to not forget the people and actors that make the city what it is today and focus future developments on creating connections and unity rather than separation and divergence.

Regional opportunities

Ulricehamn is situated in a position close to several larger cities. By road, the distances are approximately 100 km to Gothenburg, 40 km to Borås and 50 km to Jönköping. With these in a commuting distance, the city benefits from large job opportunities from the broader region, while offering the closeness to nature and cheaper housing than those larger populated areas.

With big investments into sports facilities in the recent years and a focus on construction of single-family homes, Ulricehamn profiles itself as an alternative for families who want to move away from the big cities and those who want to settle down. This can additionally be seen in the peak increase in people around 0-9 and 30-36 years of age in the city (Ohshima, 2021)

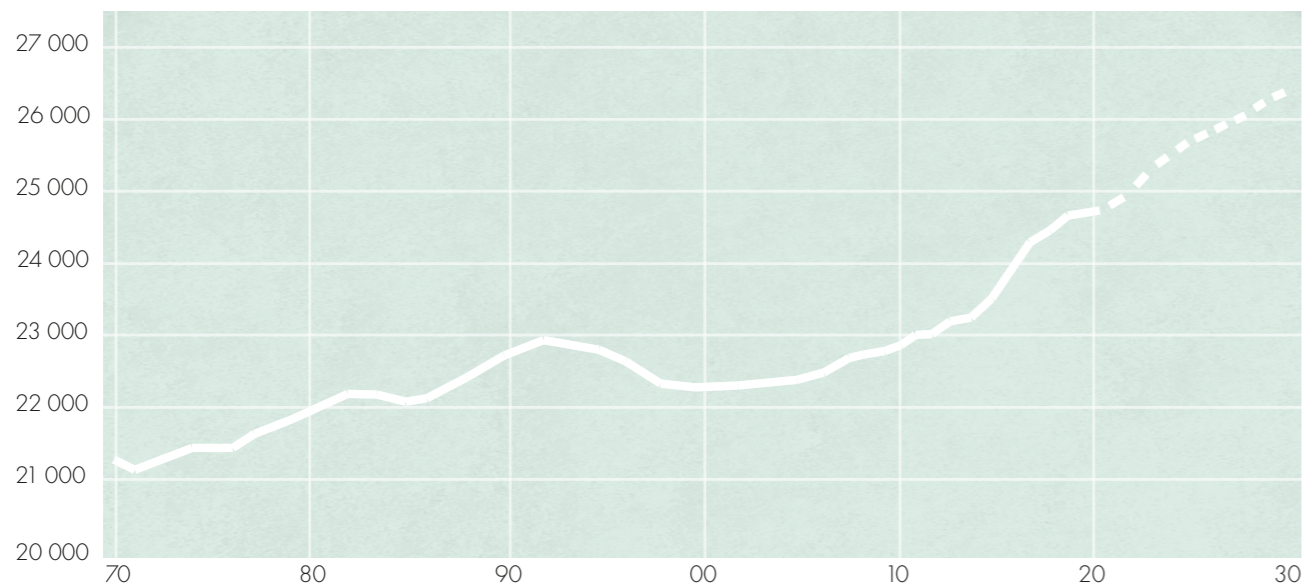

Figure 17. Population development & prognosis for Ulricehamn Municipality up to 2030, Population on y-axis and year on x-axis (Ohshima, 2021).

Importance of Social capital

In the book "Kultur, Plats, Identitet - Det lokals betydelse i en globaliserad värld", the question of why people settle in specific places is discussed. Globalisation is both seen as a contributor to the lessened meaning of the place but at the same time its importance in a world where cities and regions have to compete for inhabitants.

In recent years, work as a reason for moving has decreased, while environment, housing and culture have increased in importance, with culture often seen as a tool for growth. (Egeland & Johannisson, 2003) Out of these, two have been prioritised by Ulricehamn with culture falling behind. As the city grows bigger, and becomes more like other larger ones, it will need a good cultural scene to compete with other places and continue the population increase and positive development. In addition to being a possible tool for growth, culture is a way to showcase the identity of a place as well as bringing people together through meeting places and social arenas.

Social capital is described in the book as contacts and useful knowledge of the local context through building connections that can help with getting privileges in the area. These are more difficult to move than other forms of capital and are a reason to why people become less inclined to move after living in one place for a longer period (Egeland & Johannisson, 2003) With social capital being an additional way to make people stay in a city, the lack of a public meeting place through the library is interesting.

Connections are the base of social capital, and the project will at its core work to strengthen this, not only through becoming a meeting place between people, but also exposing them to various actors in Ulricehamn as a centre to the social web of the community.

Another definition of social capital is that of trust in a society. This can be divided into two parts; that which is found within a highly integrated group and that which bridges broader parts of a community. This is important to the democracy of a society, as a group of people with higher trust in each other and the institutions will function better. For this to occur, there needs to be meeting places where such social capital can be generated between the various groups of a city. (Aabø, Audunson, & Vårheim, 2010)

The use of the public library as a meeting place has been seen in various social groups, bridging the economic barriers of a place through creating exposition between classes. (Aabø, Audunson, & Vårheim, 2010) In terms of meetings, most seem to occur within groups of people with existing bonds, although the library as a place allows for easy transition between high- and low intensity meetings. The bridging social capital is primarily generated through being exposed to others in the same arena. (Aabø & Audunson, 2012)

As a smaller city, Ulricehamn has larger opportunities to create social capital across groups as the population is lower with established connections. As the city grows larger, there is a risk of the social capital becoming more focused within certain classes as there is today no public space that creates the bridge between groups. This is an important aspect to keep in mind as the city gradually moves away from the rural qualities it has today.

Cultural mapping

Cultural landscape of the city

Below is a list of buildings/institutions that are relevant to the cultural sphere of the city. The library, cultural school and Folkets hus are the main actors. The old Town Hall (Rådhuset) is used for exhibitions occasionally since there is no dedicated exhibition space at the library or anywhere else. The youth centre has spaces for creative production and the cultural aspect could become a larger part of it. The City Hall is where the public culture is controlled from and the place where people can take part in the democratic processes and get influence.

- 1. Culture school
- 2. Folkets hus, housing cinema and theatre stage
- 3. City Library
- 4. Old Town Hall, partially used for exhibitions
- 5. Youth Centre
- 6. City Hall

Schools and movement

Multiple schools are in walking distance and the paths used between them and the city centre either pass next to or near the site. The one between the gymnasium and city centre is highlighted in figure 18. The bus station and closest schools are marked on the map.

- 7. Bus station
- 8. Elementary and middle school
- 9. High school
- 10. Secondary school

In-depth investigations

Following are in-depth descriptions of the most relevant stakeholders in the cultural landscape of Ulricehamn. The old town hall is not a part of this since it is only used as an exhibition space which would be relocated to the new cultural centre. Other, private actors exist in the city but are not detailed or specified in the project.

City Library

The spaces that house the existing city library have for a long time been in a bad state and create a bad environment and do not enable the activities envisioned.

The more important aspects desired in a new library from the staff in Ulricehamn are to have overview in the building to make it easier for less staff to manage, a children's section that is easy to use both for kids and their parents, the media handling room where a lot of work is carried out as well as more varied spaces. There is today no separate space for having events nor any smaller rooms for studying. (Johansson, 2023)

With a Black box, there can be smaller events as well as a space both for the culture school, youth centre and other groups that would require such a space. Larger events could be held in the aula at Folkets hus in cooperation with them.

The main space of the library should be open and lively, with easy manageability for the staff. In addition to this, smaller spaces that will be co-inhabited by other actors allows for both quiet and loud activities.



Figure 18: Scale 1:5000 map of central Ulricehamn. Chosen actors, schools and pathways are showcased with green representing pedestrian pathways between gymnasium and city centre (east-west) and main shopping street (north-south). The red roads are car-passages with Bogesundsgatan being the main passage through the city centre.

Ulricehamn Culture School

Having been rebranded from a music school last year, the space for instrumental practice is where the culture school is centred. These are in an old school building with spacious, light rooms with high ceilings.

The other parts of the culture are spread around different buildings. Theatre class is in the same building, but it lacks a proper black box, show-classes as well as movie and artistic classes are held in the local Gymnasium. With them spread out, it is more difficult to create common events. (Petrini, 2023)

The culture school has started to talk with Folkets hus about using their spaces to have a proper stage for theatre and Folkets hus getting a bigger connection to the youth culture. (Petrini, 2023)

The spaces for the music classes are good and centred in one location that are appreciated by the staff, but the other parts of the culture school could gain from being collected in one place. This would create a clearer organisation with two buildings and the theatre class being housed in a building next to Folkets hus would generate further possibilities of cooperation between the actors. New and flexible spaces could additionally allow for further expansion into other artforms and classes.

Folkets hus

The building was erected in 1903 and has throughout history been used for many different purposes, such as library and association house with a permanent cinema projector added in 1903. During the 70s, it risked demolition after bad maintenance and there were talks of building a new Folkets hus. It was saved with contributions from the local bank as well as other actors in the city, showing how important it is for the cultural heritage of Ulricehamn. (Tjäder, n.d.)

Today, it houses the cinema, a stage for theatre performances and conference rooms. A few smaller spaces are also available for other actors not participating in the cultural scene. The 200-seat stage is used for the cinema, some theatre performances and other activities. The spaces are currently under-utilised and could host more activity. (Frick, 2023)

In the fall of 2022, Folkets hus had an event together with the culture school and youth centre where work and performances from them were displayed. (Frick, 2023)

Folkets hus would not gain any new spaces, but rather a potential higher occupancy for the ones they already have. With the cultural school theatre class located across the street, they could easily use the stage at Folkets hus.



Figure 19: The building housing the music classes for the culture school. Picture retrieved from google streetview.



Figure 20. Front facade of Folkets Hus towards Nygatan, facing the site of the project.

23.02.06 13.16

Ungdomens hus

The building housing the youth centre today is small and often gets crowded. They have spaces where the youth and children can play video games, create music and talk. There is a lack of places to sit, smaller rooms to enable people to hang out in different groups and somewhere that could be a place for only girls. With the building having two floors, it is also more difficult to get an overview for the youth leaders working there. (Jomaa, 2023)

Added space would allow for different groups at the youth house and a larger variety of activities. Some of the spaces that could be accessible would not be feasible to build for the youth centre alone, such as the black box and studios. Placing the parts that they would most often inhabit directly connected to the existing building would make it easier to manage and for them to make use of the new spaces.

City Hall

The city hall is an iconic building in Ulricehamn. Finished in 1957, based on the proposal "Forum Contorum" designed by architects Sten Hummel-Gumaelius and Viking Göransson, it was a symbol for the modern age. Constructed using locally manufactured bricks and other sturdy materials, it is a building that has aged well. (Vermelin, 2017) The building consists of four volumes as seen in figure 21: The pillar house (nr 1), The art gallery house (nr 2), The tax house (nr 3) and The Highrise (nr 4)

Today, the building is primarily used for office space, housing many of the people working for the municipality. The previous art gallery is a lunchroom, but other than that the use of spaces is similar to when the building was erected. The

reception of the city hall felt authoritarian and sterile when visiting. It was not a place one would simply enter and which could be improved to encourage higher interaction.

A part of the project is to incorporate the reception of the City Hall into the cultural centre, to make it more welcoming and accessible to the inhabitants of the city. This is not a desire from the City Hall, but an opportunity seen at the visit and by Eldås & Carlsson (2022).

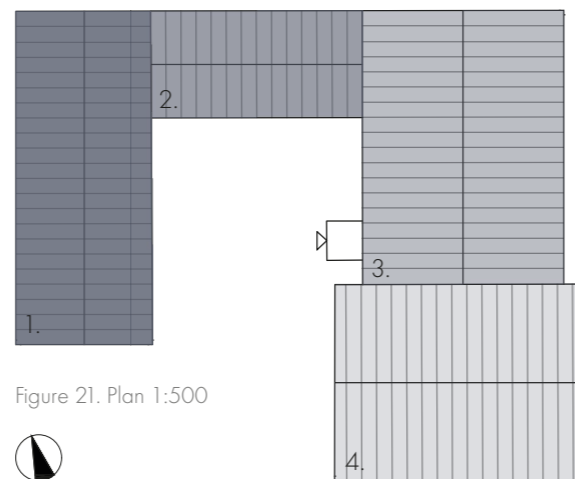

Figure 21. Plan 1:500

Cooperation exists between some of the actors, strengthening the plausibility of it working in the new cultural centre.

The library could benefit from having access to spaces used by some of the other actors, creating co-occupied functions.



Figure 22. Ungdomens Hus as seen from the northeast

23.04.17 15.21



Figure 23. The City Hall as seen from the southwest with Folkets hus in the background.

23.04.17 15.41

Site Analysis



Figure 24. Scale 1:1000 plan with chosen site marked with the dashed square, Figures 26-28 are photographs on the next spread. Height curves on the plot show a difference of one meter.

A gap between existing actors

The site of the project is a parking lot behind the City Hall, in front of Folkets Hus and next to the Youth centre. On the other side of the City Hall is the main square of the city and further on, the main shopping street. It is a central location that allows for many physical and visual connections.

Today it is used for parking and creates a void in the city-scape. The site is 100 meters away from the main square and main shopping street. 250 meters away is the secondary school and one of the elementary and middle schools of the city.

The site is sloped, with different heights on every side of it, with the lower side towards the lake in the west.

The main bus station is 350 meters by foot and a bus stop is also located between to the city hall and main square.



Figure 25. Scale 1:4000 plan of central Ulricehamn with roads of interest marked.

Roads

Nygatan which the site is located at is a less busy street with much of the traffic going through Bogesundsgatan and Strandgatan. Storgatan or "Gågatan" as it's called is the main shopping street of the city. Rådhusgatan connects Nygatan and Bogesundsgatan through a pedestrian passage.

- 1. Strandgatan: Heavy traffic passing through the city.
- 2. Storgatan/"Gågatan": Main shopping square, pedestrian.
- 3. Bogesundsgatan: Heavy traffic passing through the city.
- 4. Nygatan: Street with less traffic.
- 5. Rådhusgatan: Pedestrian access to the Gymnasium.



Figure 26. Site as seen from the southeast, City Hall to the left and Youth centre to the right. 23.04.17 15:18



Figure 27. Site as seen from the back of the Youth centre. 23.02.10 10:30



Figure 28. View towards city centre from Rådhusgatan 23.04.17 15:43



Figure 29. Scale 1:1000 plan of site

Usage of the site today

The main parts of the site consist of parking space represented by the rectangles. The thick, black lines represent pedestrian paths.

Rådhusgatan which connects Folkets hus to the east and the main square to the west which has no passing traffic is also partly used as parking, which could instead be used to create a wider passage for pedestrians.

A & B are entryways to the courtyards and parking spaces for residents, so cars will still need passage to them from Bogesundsgatan and Nygatan respectively.

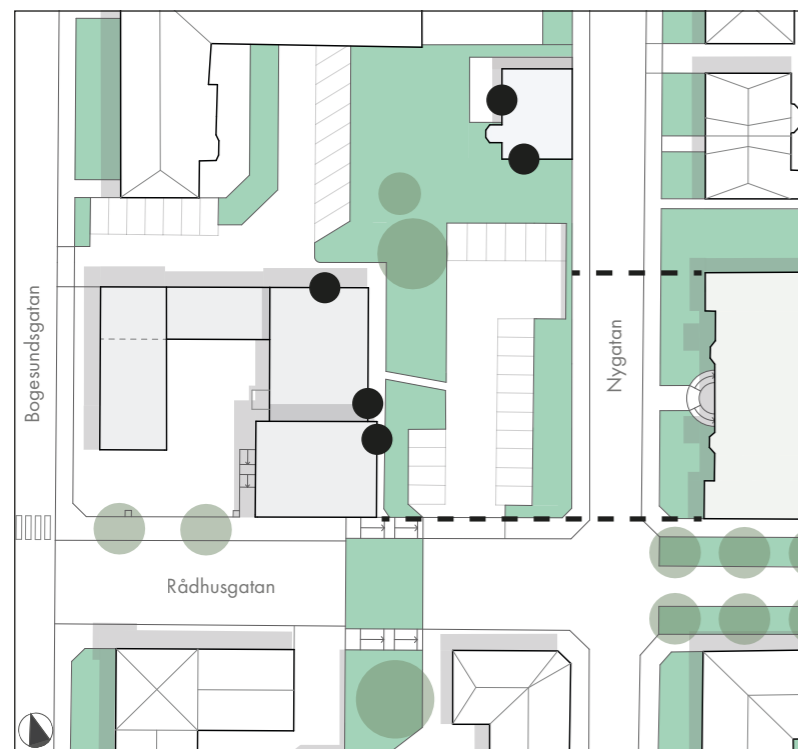

Figure 30. Scale 1:1000 plan of site

Connecting to existing buildings

The site is as the rest of the city sloped, with a possibility of entrances from multiple levels. The dots showcase possible points of physical connection to the existing buildings.

The entrance facade of Folkets Hus also needs to be addressed by the new building as it is one of the most iconic buildings in the city.

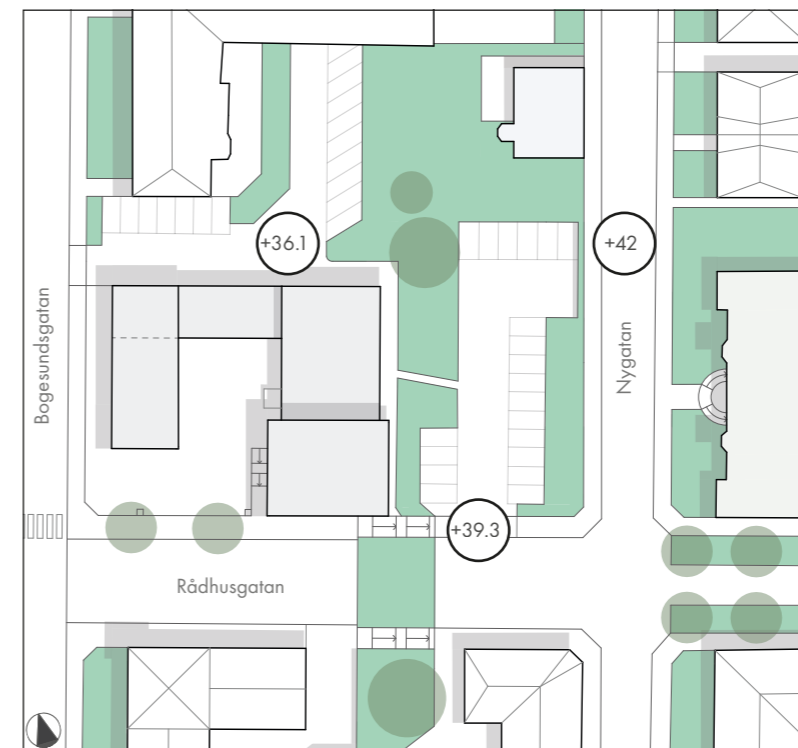

Figure 31. Scale 1:1000 plan of site

Height differences

As with all of Ulricehamn, there is topography to be considered. The filled circles showcase the different heights over the zero-plane of the city that the edges of the site has.

Accessibility via and past Rådhusgatan needs to be considered since it is today only passable via stairs with the large difference in height.

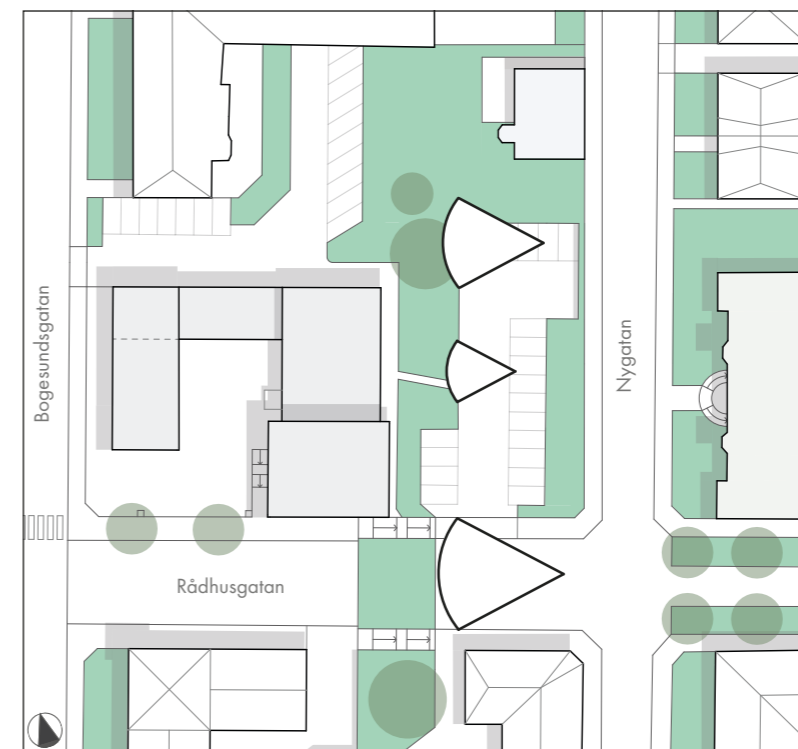

Figure 32. Scale 1:1000 plan of site

Views

With the City Hall being located at the site, the views towards the lake are varied. The clearest sight is at the south and north of the City Hall, and partly at the centre when being on the level of Nygatan and one level further up.

Urban analysis

Nygatan

The street is mainly lined by two- to four story apartment buildings and has more of a dense city characteristic than most streets in Ulricehamn where the space between buildings are generally larger.

Meeting the street

There is a distinction between the western and eastern sides of the street in the distance to the facades. On the west side, towards the lake, the buildings stand next to the sidewalk. On the eastern side, there is a front garden adding space between the road and facades. This creates a hierarchy on the street with the eastern side being more dominant.

Another aspect making the eastern side more dominant is the height of the buildings. The western side is filled with facades of two floors and in some cases an attic with apartments. The eastern side is characterised by three to four story facades further adding to the hierarchy. Both these aspects reflect the topography of the city where many plots are sloped, creating a difference in height on the two sides of the buildings.

Cut corners

Another strong characteristic of the western side is the cut corners of the buildings at crossings to mark where a road leads down west towards the city centre.

A distinct feature of the street is the use of the typology to create either high, dominant front facades or a lower scale on the front with the back opening towards the view.

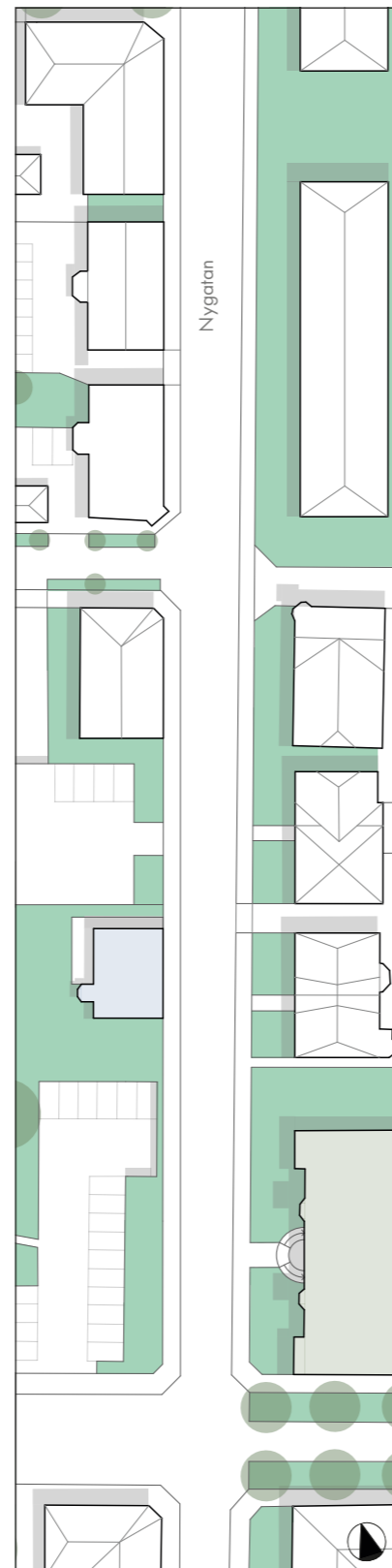

Figure 33. Scale 1:1000 plan of Nygatan.

Older wooden architecture of Ulricehamn

A feature found on much of the older wooden buildings of Nygatan and the wider city context is a clear horizontality in the facades. Either through a pronounced våningsband/Gördellist or Sockelgesims. These are used to much effect together with a varied horizontal and vertical facade in many of the buildings. The facades are often not clad in one pattern throughout like in more modern buildings but split into parts or with certain elements pronounced.

These horizontal elements are many times painted in a different colour to the main facade adding another layer of dimensionality to them. Examples of these features can be seen in figures 35 - 38 below.

The use of *Våningsband* and *Gördelgesims* as facade elements characterises much of the older wooden buildings in Ulricehamn.

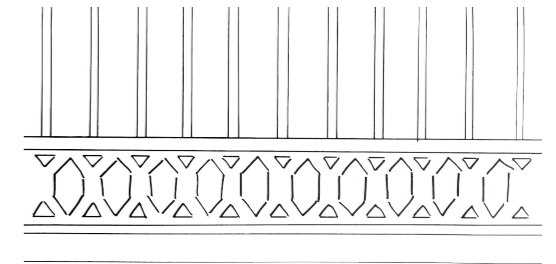

Figure 34. Sketch of ornate *Våningsband* from one of the buildings at the main square in Ulricehamn.



Figure 35 & 36. Rådhuset & Nygatan 15



Figure 37 & 38. Nygatan 4 & 13

Brief

The building brief is about creating a meeting between different needs and possibilities. The spaces included are based on the answers from the interviews with the actors through me translating their thoughts into functions. It is not based on any specific spaces asked for by the actors but rather an idea of what the building could contain to cater to the needs and wishes mentioned and what that was found during the visits.

The goal of the building is to create meetings and connections, to bring together the city under one roof. To do this, there were certain spaces that needed to be included.

The main part of the building is a new library, with large, open spaces containing books, seating areas, receptions with cafés and spaces for children. The integrated café and reception is to avoid the strong separation of these seen in the reference project, and to create a better third place.

The sizes of spaces in the brief are based on Kulturhuset Bergsjön and a proposal for a new library in Ulricehamn. (Topo Arkitekter, 2022), (Sweco, 2020)

Incorporating the actors into the building

- New spaces for the city library
- Extended space for the youth centre
- New spaces for part of the culture school
- Reception and spaces to create more approachable interactions with the City Hall
- Creating a higher occupancy at Folkets hus
- Spaces for other actors such as associations, cultural creators and companies to use.

Existing buildings on the plot

The City Hall is mainly used as office space for the municipality with conference rooms and the Council hall in addition to large amounts of smaller office rooms. It is spread over five stories and a basement with the entrance at level with Bogesundsgatan.

The smaller youth centre has several spaces for different functions spread over two stories with the entrance at level with Nygatan.

City Hall	
Office space	1200 m2
Conference rooms	150 m2
Council Hall	120 m2
Lunch room	90 m2
Archive	70 m2
Entrancé hall	60 m2
Reception	30 m2
Total	2800 m2

Youth centre	
Entrance	25 m2
Lounge	40 m2
Kitchen	10 m2
Seating area	22 m2
Gaming room	25 m2
Music studio	35 m2
Office	12 m2
Total	200 m2

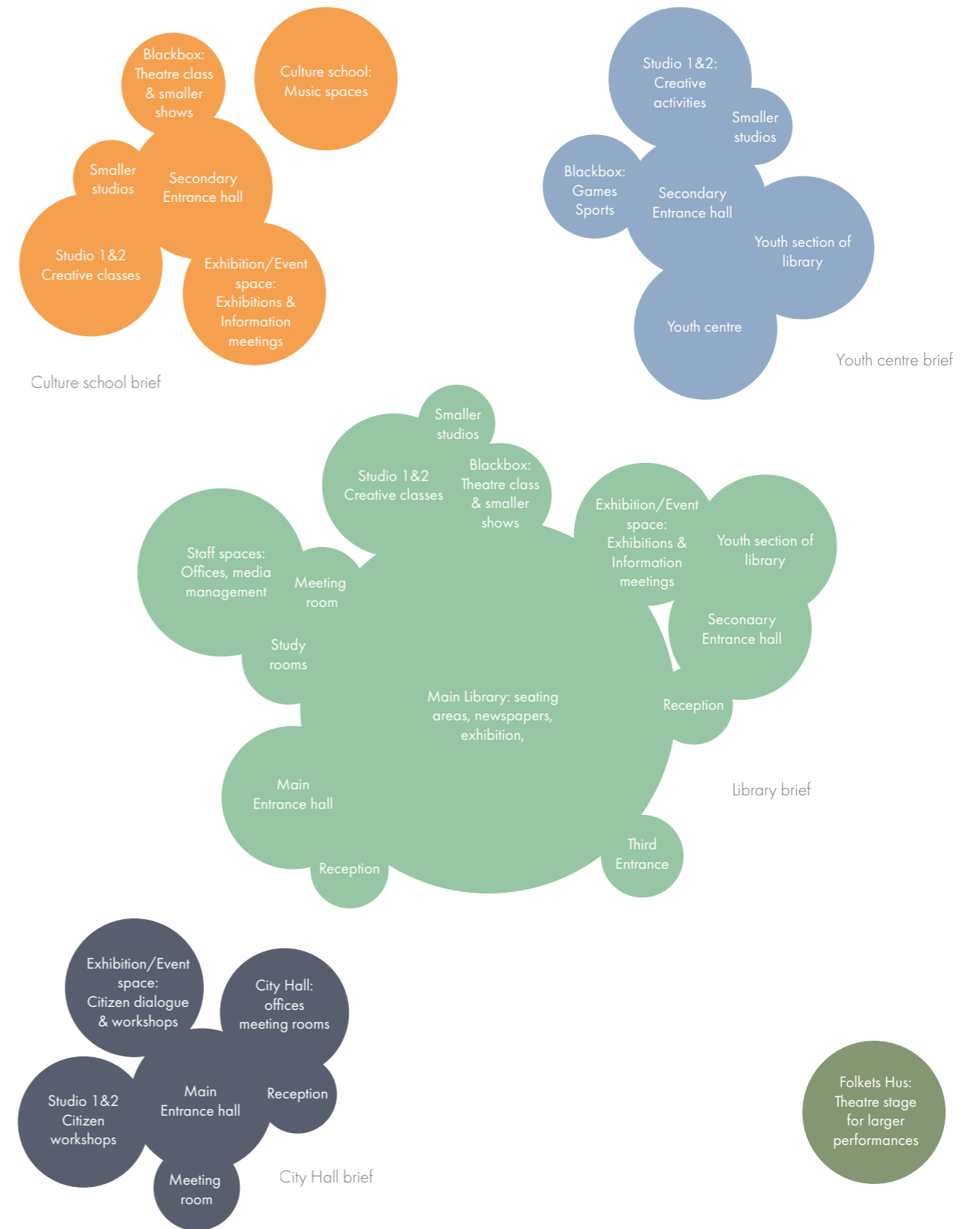

Figure 39. Individual briefs for the actors included in the project.

Existing buildings on the site

The city hall is mainly used as office space for the municipality with conference rooms and the council hall in addition to large amounts of personal office rooms. It is spread over five stories and a basement.

The smaller youth centre has several smaller spaces for different functions spread over two stories.

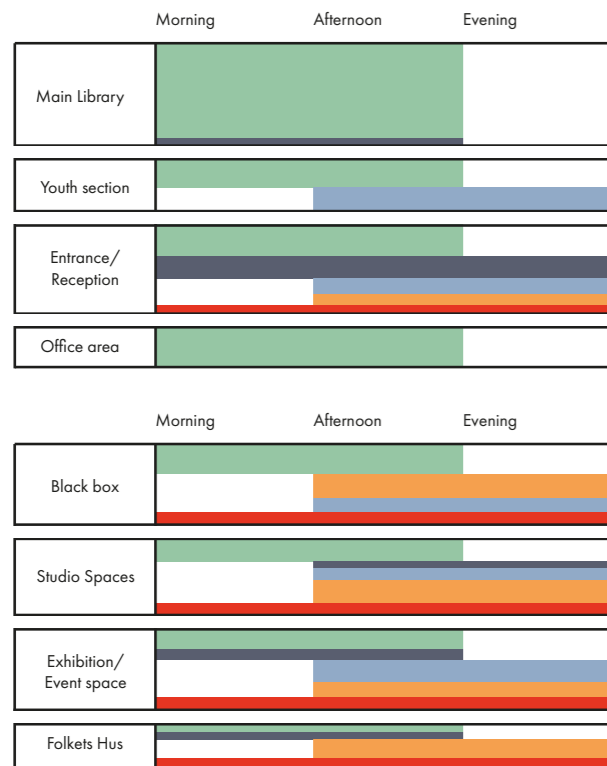
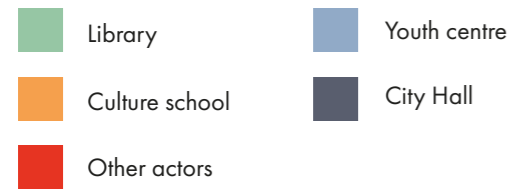

Figure 40. Diagram showcasing the potential usage of different spaces during a day.

Next page: Figure 41. Building brief with spaces and connections.

Main Library	600 m2
Childrens library	150 m2
Entrance Halls	2 x 85 m2
Loading area/ Staff entrance	50 m2
Silent study rooms	3 x 9 m2
Study area	50m2
Receptions	2 x 30 m2
Youth Section	75 m2
Exhibition/ event space	90 m2
Studio 1	30 m2
Studio 2	40 m2
Ceramics room	7 m2
Music studio	20 m2
Black box	60 m2
Storage rooms	50 m2
Archive/ Storage room	120 m2
Ventilation	80 m2
Technical spaces	50 m2
Offices	63 m2
Silent rooms	2 x 6 m2
Copy room / Storage	6 m2
Entrance space	12 m2
Resting room	8 m2
Lunchroom	32 m2
Dressing room + WC	10 m2
Media handling	30 m2
Conference room	20 m2
Restrooms	25 m2
Communication	450 m2
Total	2400 m2

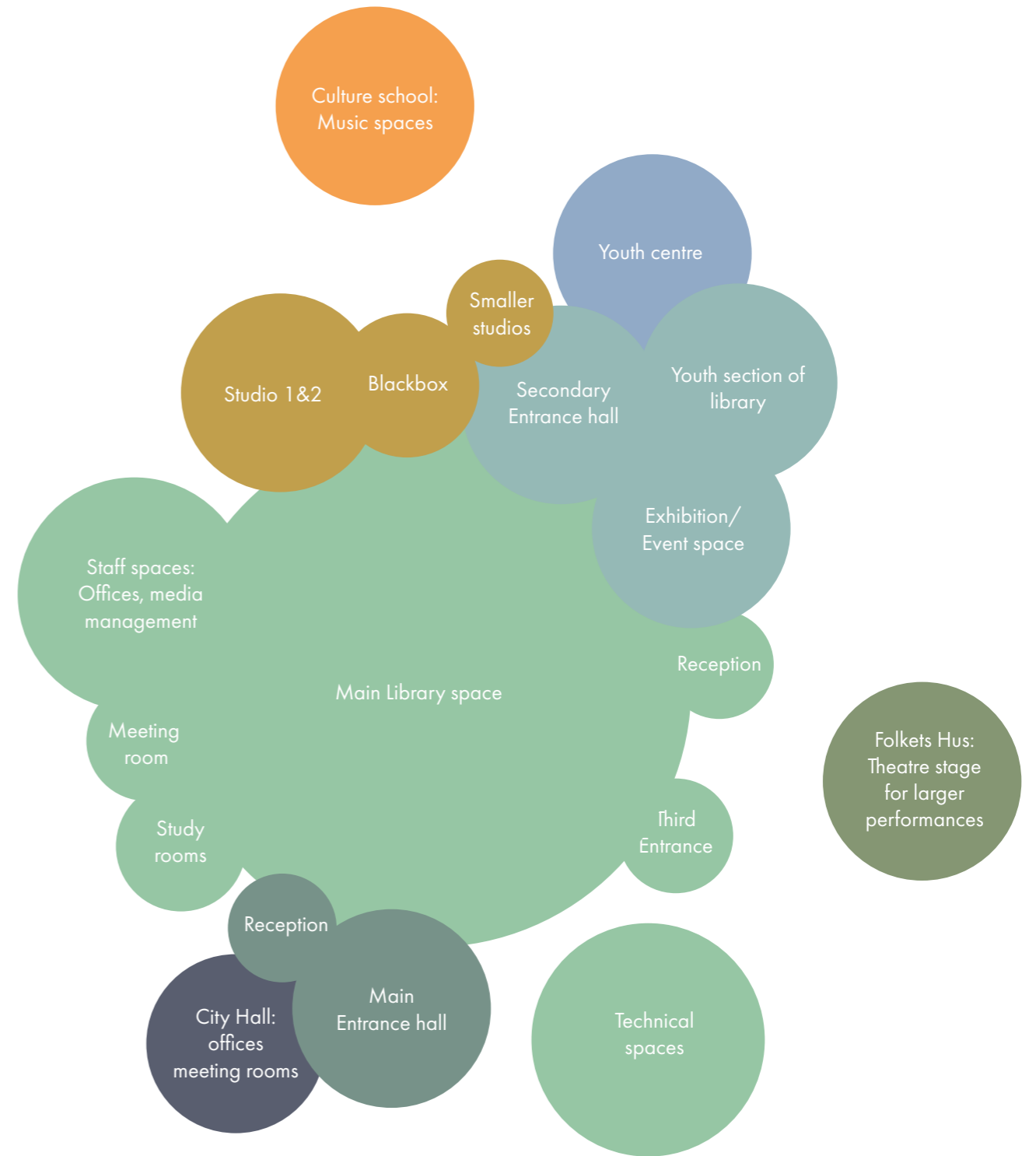



Figure 42. Second entrance of the building connecting it with the existing Youth centre.

Design research

Process - applying the investigation

Design proposal

Context

Building layout

A living room for Ulricehamn

Generating meetings

Housing the actors

A day in the cultural centre

Sections

Design principles

P. 53-79

Process - applying the investigation

Creation of the building plan and connections

A process diagram describing the evolution of the building plans can be seen in figure 43, with spaces represented by the colour of the actors primarily using them.

1. The first sketches envisioned the building connected with the City Hall to the north, and an open, slender yard between the buildings with the main entrance on the gable of the building.
2. After visiting the existing buildings, the physical connections to them changed and the entrance halls came to be. Dedicated spaces for the actors were positioned in the building. The second floor was added to house the offices and study spaces.
3. The connection to the City Hall moves into the existing building and a gradient is added to the spaces to showcase the use of the same space by multiple actors.



An approachable building

For the interior spaces of the building to invite people in, the main part of the library is located along Nygatan and towards Rådhusgatan. The spaces with a lower occupancy such as the offices, workshops and Black box are turned away from the street towards the back, allowing them to temporarily be outside of the active space without lowering the sense of liveliness in the building.

Creating overview between functions

The library space is designed with openness in mind, creating visual connections between the three levels.

For the City Hall to feel connected to the centre, the new reception at the main entrance is a part of both the library and a section of conference rooms occupying part of the current office area in the existing City Hall building, allowing their function to be visible without intruding spatially into the library zone.

The secondary entrance allows for the Youth Centre to occupy part of the library while being open for the Cultural school or other actors, not fully separating them into different parts of the building but instead creating cohabitation without disturbance, as it is important that they do not dominate the space, forcing other groups away. Therefore, they are located in a corner, easily cut off aurally.

Integrating the actors

The traditional library café is in the project fully integrated in the space through the receptions. The library also has access to varied spaces for creating high-intensity meetings based around activities and cultural production as well as low intense meetings through the co-occupancy of the spaces, catering to the changing landscape in culture 3.0.

Flexible spaces for multi-use and changeability

Rooms in the building are large enough to house multiple activities and with proper storage to enable easy transition.

A large part of the flexibility is the access to spaces separately from one another and allowing for smaller parts of the building to be occupied at specific times. This has been central in the layout of the plans, allowing for multiple configurations of spaces, letting actors use varied amounts of the building depending on their current needs.

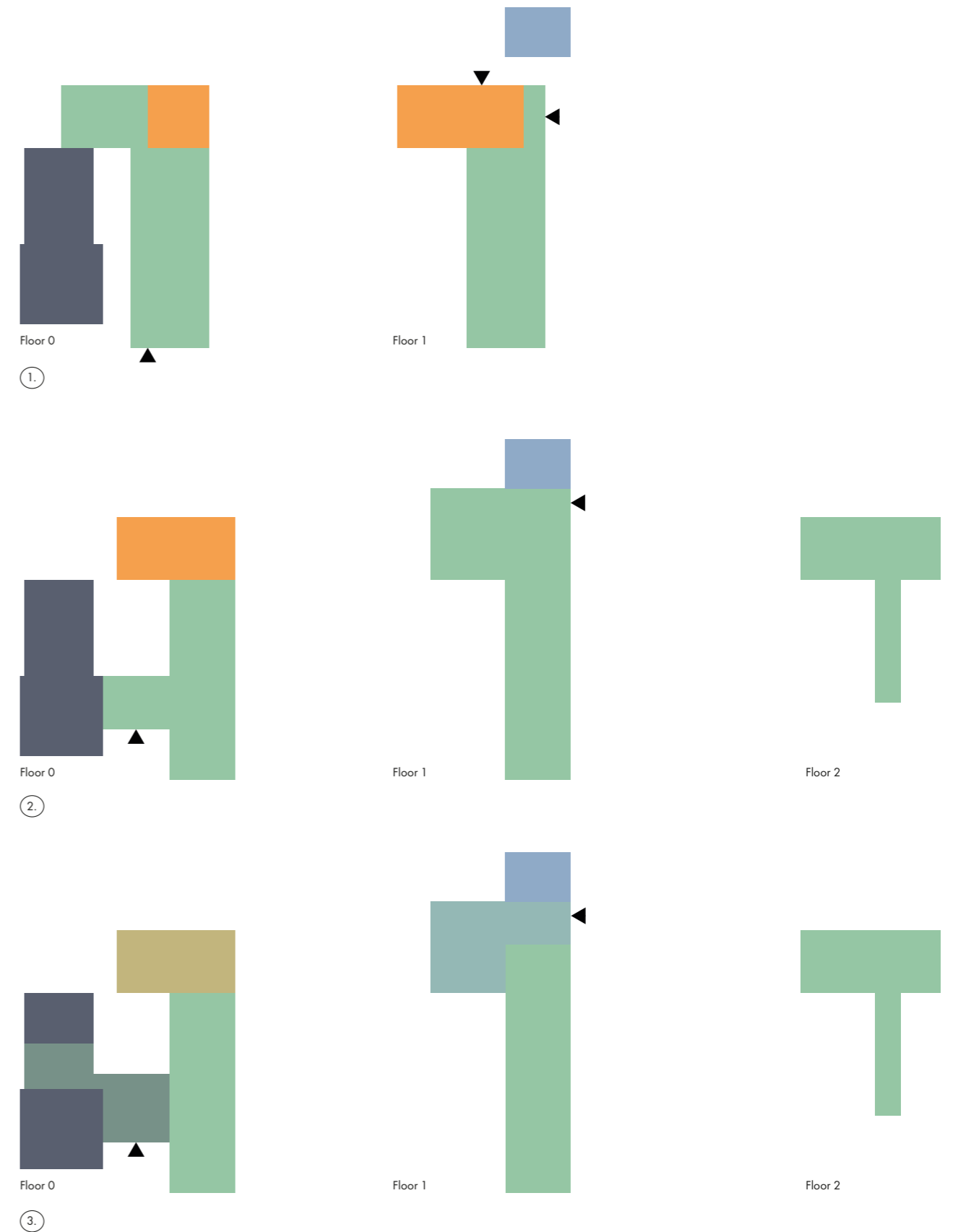
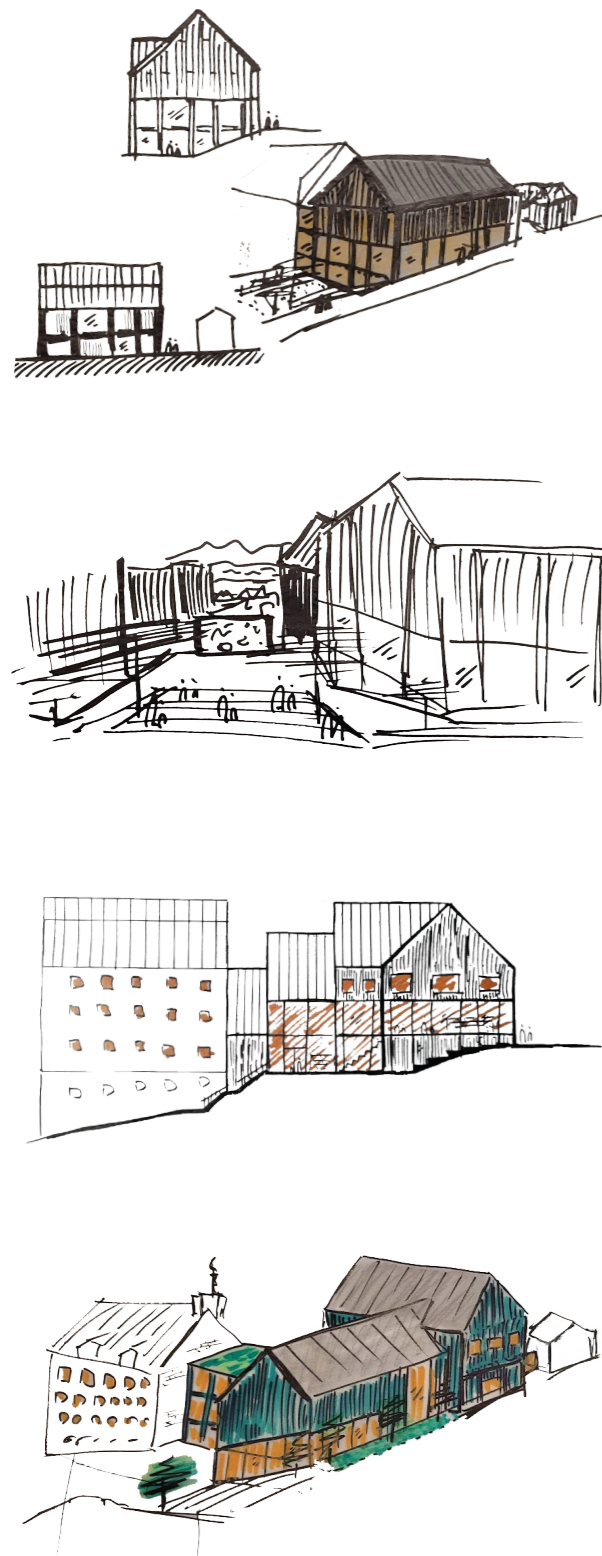

Figure 43. Diagram showcasing the plan design process.



Creating a volume

Figure 44 shows some sketches made during the process to find the visual language of the building and how to break it up into volumes. Figure 45 describes the process to end up with the building as it is in the final proposal.

1. The building volume was stretched along the site to make use of the views to the south and north of the City Hall. The northern volume has three stories to make use of the best location for sight towards the city.
2. The new building was then connected to the City Hall and Youth centre through two entrance volumes, distancing the new to the existing while joining them together.
3. A partial third floor was added to the larger volume to allow for more secluded spaces in the building that additionally made the most of the views towards the city centre.
4. The main volume was clad with a gable roof, taking inspiration from the City Hall. The entrances have flat roofs to create the distance from the existing structures visually.
5. The gables of the building were cut to direct people from Nygatan towards the entrances. This is an interpretation of the cut corners of buildings found on the street. The back gable of the northern volume is additionally cut to create space between the buildings where they are not purposefully joined together.
6. The building as it looks in the final proposal.

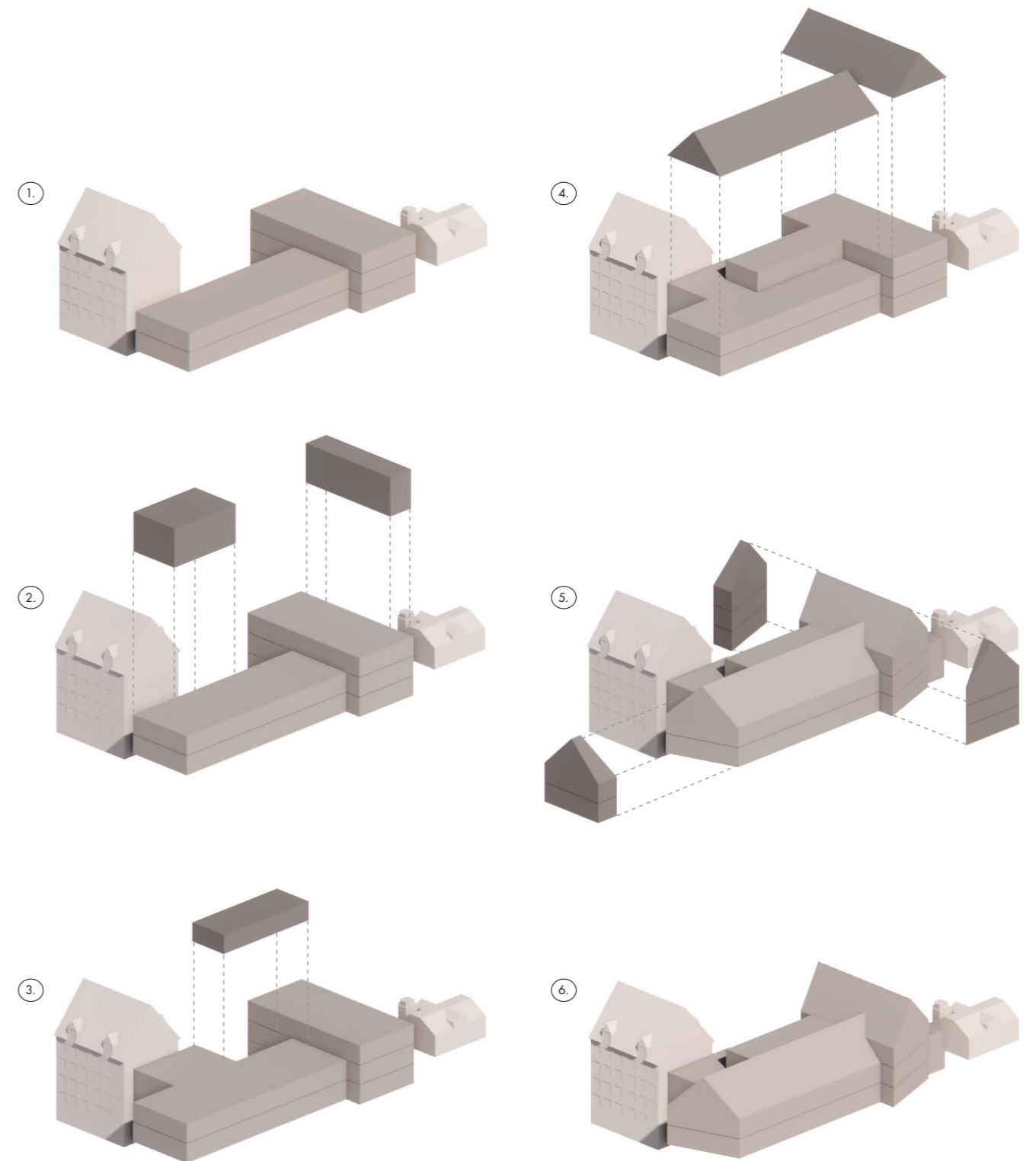

Left: Figure 44. Sketches of exterior expression of the building.

Next page: Figure 45. Diagram showcasing the design process of the building volume.

Design proposal



Figure 46. Site plan, scale 1:1000. Showcasing new building in the context and changes made to Rådhusgratan.

Design as research

The design proposal is used to apply the findings from earlier chapters onto the context of Ulricehamn and the specific site. It is not intended as the end result of the thesis, but rather a tool to enable the discussion on the topics.

Filling a gap

A new structure is created between the existing actors, connecting them and filling a gap both in the cityscape and cultural scene of the city.

Rådhusgratan is made into a more pedestrian-friendly street and a small square is created in front of the main entrance, acting as an extension of the city square below.

The centre becomes a node of knowledge through the library, offers various types of meeting places and a cluster of functions for the creation of and participation in culture. The gap filled is not only a physical one in the cityscape, but a more intangible social one as well.

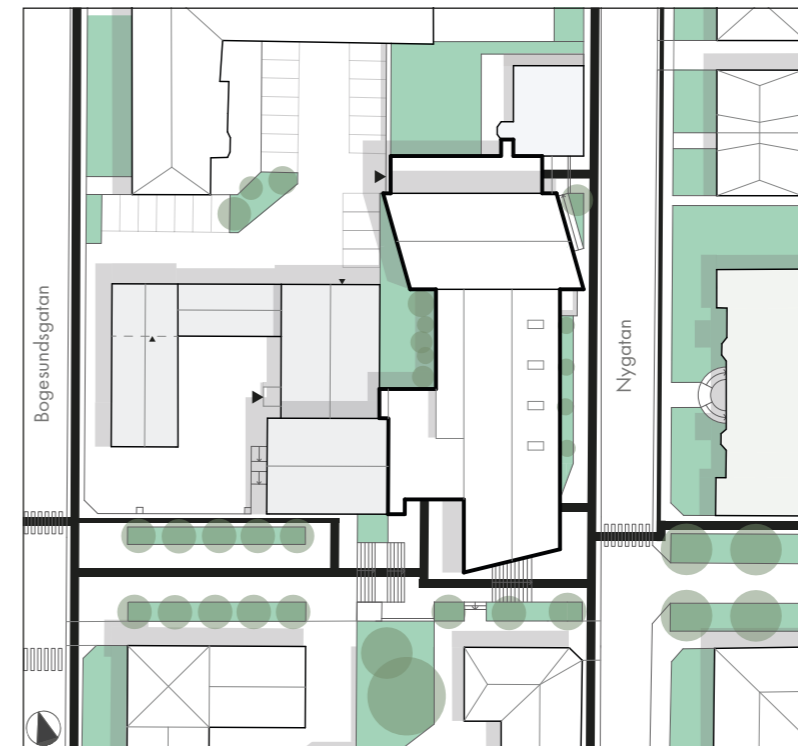

Figure 47. Scale 1:1000 plan of the site showcasing movement paths.

Redirecting movement

Rådhusgratan is a street with a lot of people passing by, being the main connection between the gymnasium to the east and city centre to the west in addition to connecting Nygatan with the main square.

With the building extending out into this street, it crosses the existing path to create end points to lines from both sides, directing people into the centre. The cut gables additionally directs people from Nygatan to these and eases the way this meeting with the building is experienced when approaching from the east.

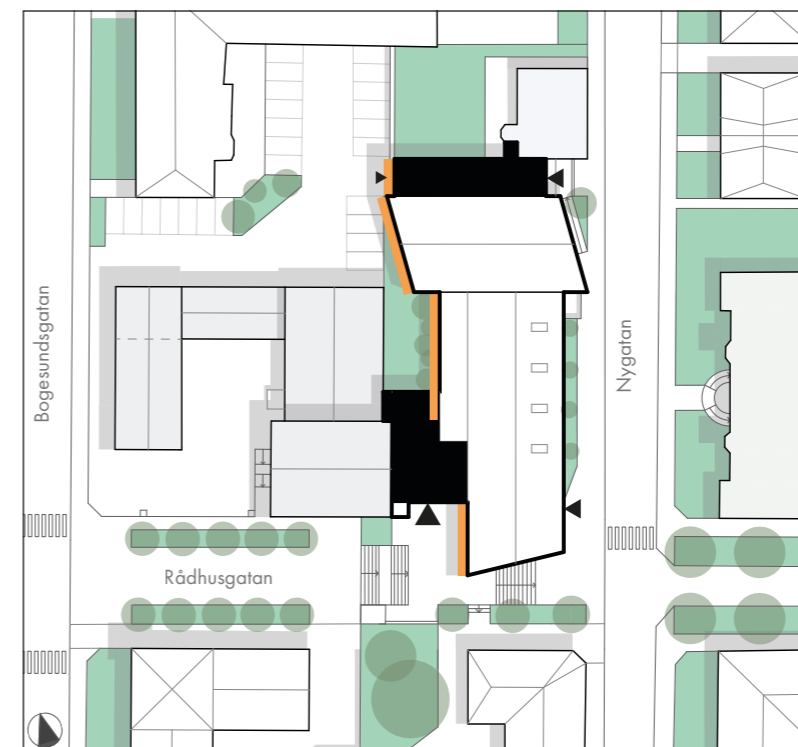

Figure 48. Scale 1:1000 plan of the site showcasing Entrance areas and which parts of the building has views towards the city centre and lake below.

Connection points & views to the city

The building extends north south to make use of the views towards the lake and city centre below. This is also achieved over part of the City Hall, with only the taller body fully blocking the line of sight. The areas with views towards the west are marked in orange.

The connections with City Hall and Youth centre are made through the two entrances of the new centre which additionally creates entrance points to the existing buildings.



Figure 49. Axonometry of the building and surroundings as seen from the southeast. The building is slightly lower towards Rådhusgatan and Nygatan, creating more approachable entrances.



Figure 51. The main entrance connects directly to the City Hall, creating a more open entrance to both institutions. Used only during the day when the library and City Hall is open.

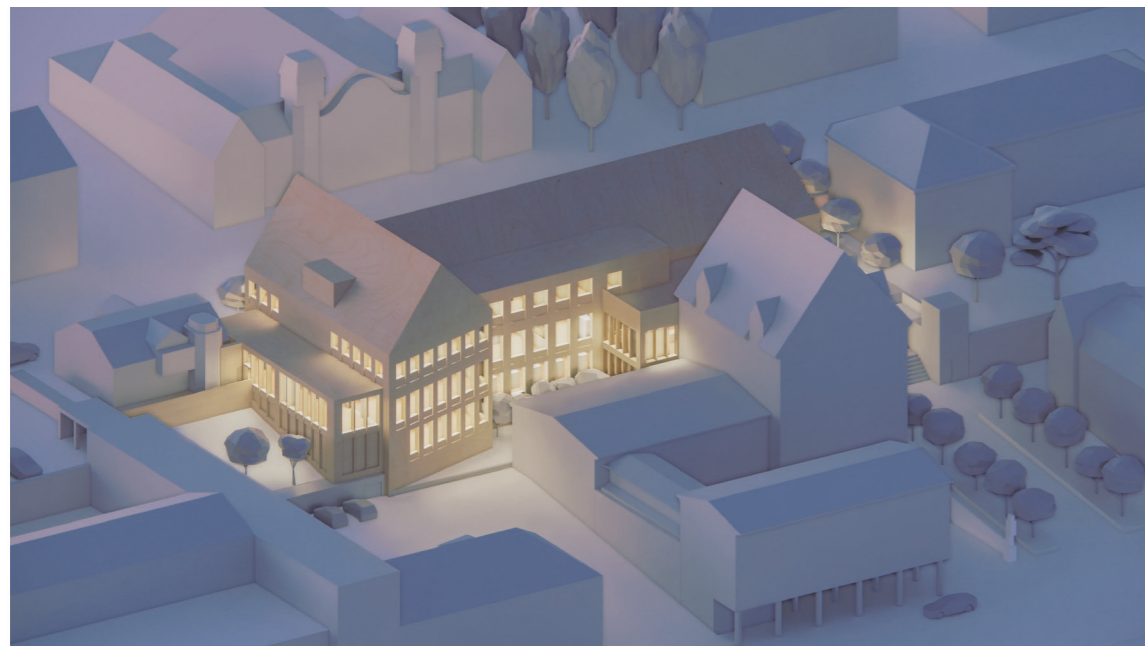

Figure 50. Axonometry of the building and surroundings as seen from the northwest. The back of the building is taller, making use of the topography to create more spaces with views towards the city centre and lake below.



Figure 52. The second entrance becomes the primary one later in the day when the library is closed but the other actors still use the building.

Context

Working within the cultural landscape

The volume of the building creates a visual continuation of the City Hall that climbs up the hill and connects Bogesundsgatan and Nygatan with the steep, pitched roof on a simple volume a central part of the design.

The building is lower and more contained in expression towards Folkets hus while also stepping away from the street, opening up a space between the two. The entrances and focal points of the building are located elsewhere to allow the grand front facade of Folkets hus to breathe while creating a semi-square between the two, as seen in figure 49.

The building has a wooden facade, taking inspiration from the older buildings on Nygatan. The Gördeldesims is a central part of the expression both on the walls and roof, adapting a feature commonly found in the context, as seen in figures 53-55. The roof is a board roof which is not found elsewhere in the city and becomes a new addition that sets the building apart from the surroundings.

The entrance volumes are clearly distinct from the rest with their flat roofs and glass facades, making a clear distinction between new and old and allowing the main volume to stand on its own.



Figure 53. Section of the facade, showcasing the pattern inspired by the older wooden buildings on Nygatan.

An approachable building

A part of the approachability is the scale of the building. The sloped site allows for the taller parts of the building to face the back, where most people will not approach the building from, as seen in figure 50. The facades towards the fronts (south and east) are lower and allows for a building that opens up once entered. The building therefore does not become daunting, and with the entrance volumes lower than that of the main building, the scale becomes more approachable.

The placement of the entrances is both based on connecting to the existing structured in a good way, but also capturing the movement along Rådhusgatan. The main entrance is easily reached from the city centre below, while the smaller entrance in the southeast crosses the path from the Gymnasium down towards the central city, allowing for easy entry.

Minding the hierarchy between new and old

The steep pitched roof is a central part of the design, and mirrors that of the City Hall. The highest point of the main volume is slightly lower than that of the City Hall while the roof is bigger and higher since the building is wider. The buildings therefore converse visually and are bigger than the other in different ways. The higher northern volume is taller than the City Hall but becomes more of a mirror with the distance between them.

With the cultural centre both standing above the City Hall and crawling into it a bit, the design aims to showcase the relationship between municipality and inhabitants. The centre is the living room for Ulricehamn, and the municipality and politicians work for the people of the city, therefore the new building is allowed to rise above. From the main Square, and the city below, the new building is slightly hidden behind the City Hall, allowing it to still be more dominant in that historical space.



Figure 54. Facade of southern volume towards Nygatan.



Figure 55. Facade of northern volume and second entrance connecting to the Youth centre.

Building layout

Adapting the brief

The design of the building combines the brief, investigations and site study to create a centre housing the various actors while generating a new type of democratic meeting place in Ulricehamn. It is a space that combines the knowledge node of the library, spaces for cultural production and consumption as well as various meeting places as a response to the more participatory culture 3.0 and a need for third places and new democratic arenas.

Floor -1

Staff entrance, loading area for the building and archive. Can additionally be used as a secondary entrance with proximity to accessible parking spaces on the back of the building.

Floor 0 / Ground floor

The main entrance to the building from the city centre which also connects to the City Hall. Half of the main library space is located on this floor along with café, children's library in addition to the studio spaces and Black box. These are additionally accessible from the second entrance, allowing for use after closing hours of the main library spaces.

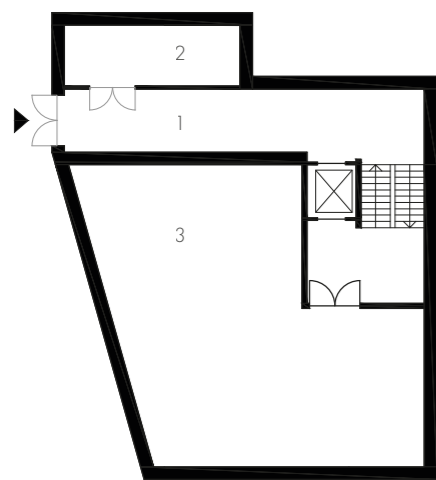

Figure 56. Floor -1, 1:300

Floor 1

The second entrance from Nygatan connects the building to the Youth Centre while allowing them to directly use the youth section of the library. There is a second reception for increased overview, an exhibition/ event space which can be used separately and the upper half of the library space. The second entrance acts as the main one during the evenings when the library is closed.

Floor 2

The main part of the upper floor is office space for the staff of the building, offering the best views. There is a meeting room also open to the public, several study rooms and an indoor balcony for those who wish to have a calmer, more focused atmosphere. The rooftop terrace can be used for events where outdoor space is wanted, otherwise not being in use.

Floor 3

Technical spaces, mainly ventilation, are located at the top of the building in the space created by the high roof.

- 1. Loading bay/ staff entrance
- 2. Recycling
- 3. Archive
- 4. Technical spaces
- 5. Ventilation

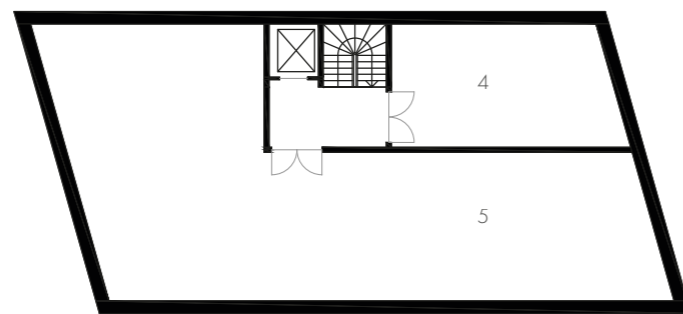

Figure 57. Floor 3, 1:300

- 1. Main Entrance hall/ Reception & café
- 2. Waiting room
- 3. Conference rooms
- 4. Main library space
- 5. Cleaning central
- 6. Childrens library
- 7. Hideout/ play area
- 8. Breastfeeding room
- 9. Storage
- 10. Black box
- 11. Music studio
- 12. Accessible restroom
- 13. Restroom
- 14. Studio space
- 15. Ceramics room

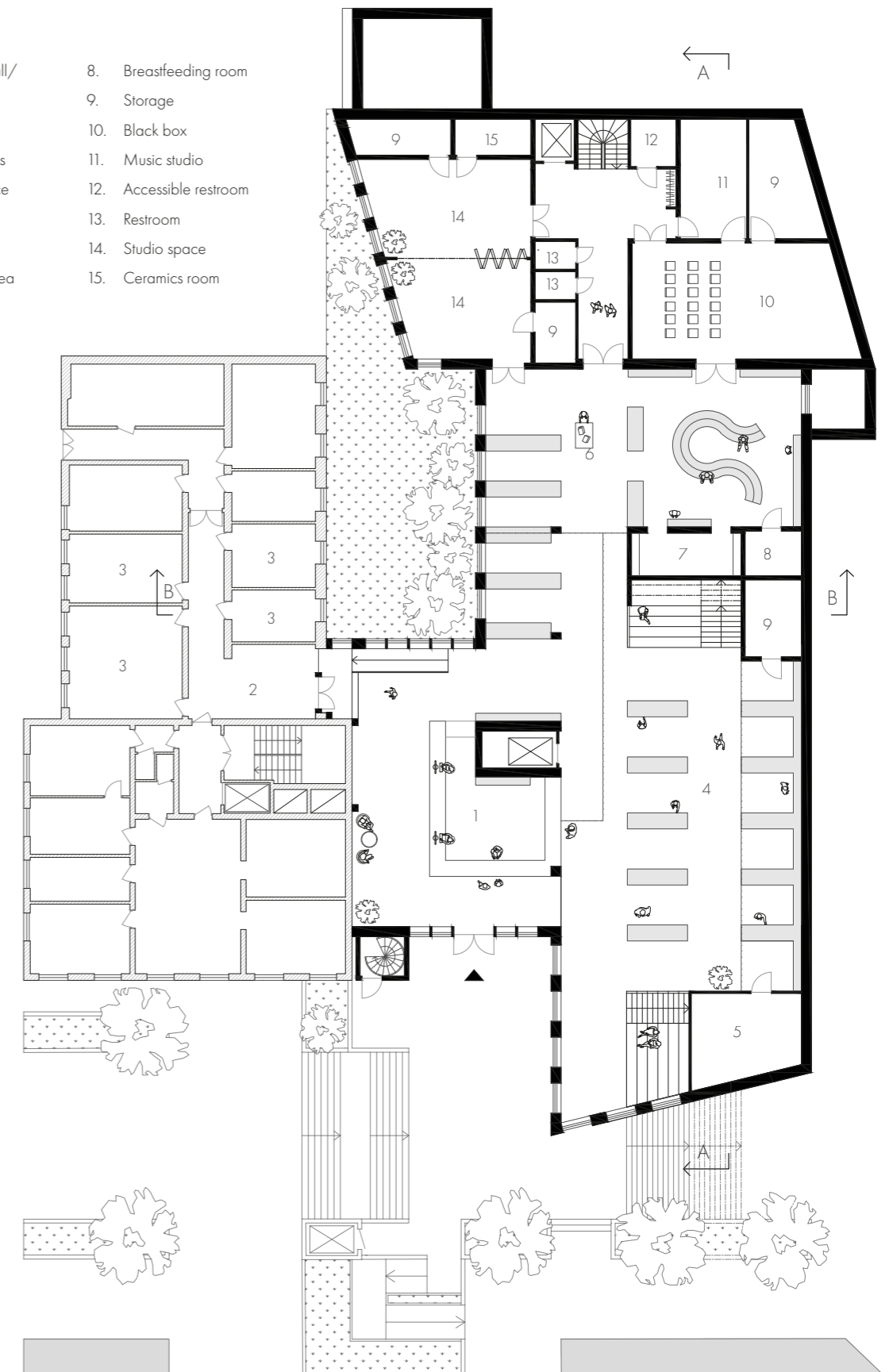

Figure 58. Floor 0, 1:300



Figure 59. Floor 1, 1:300

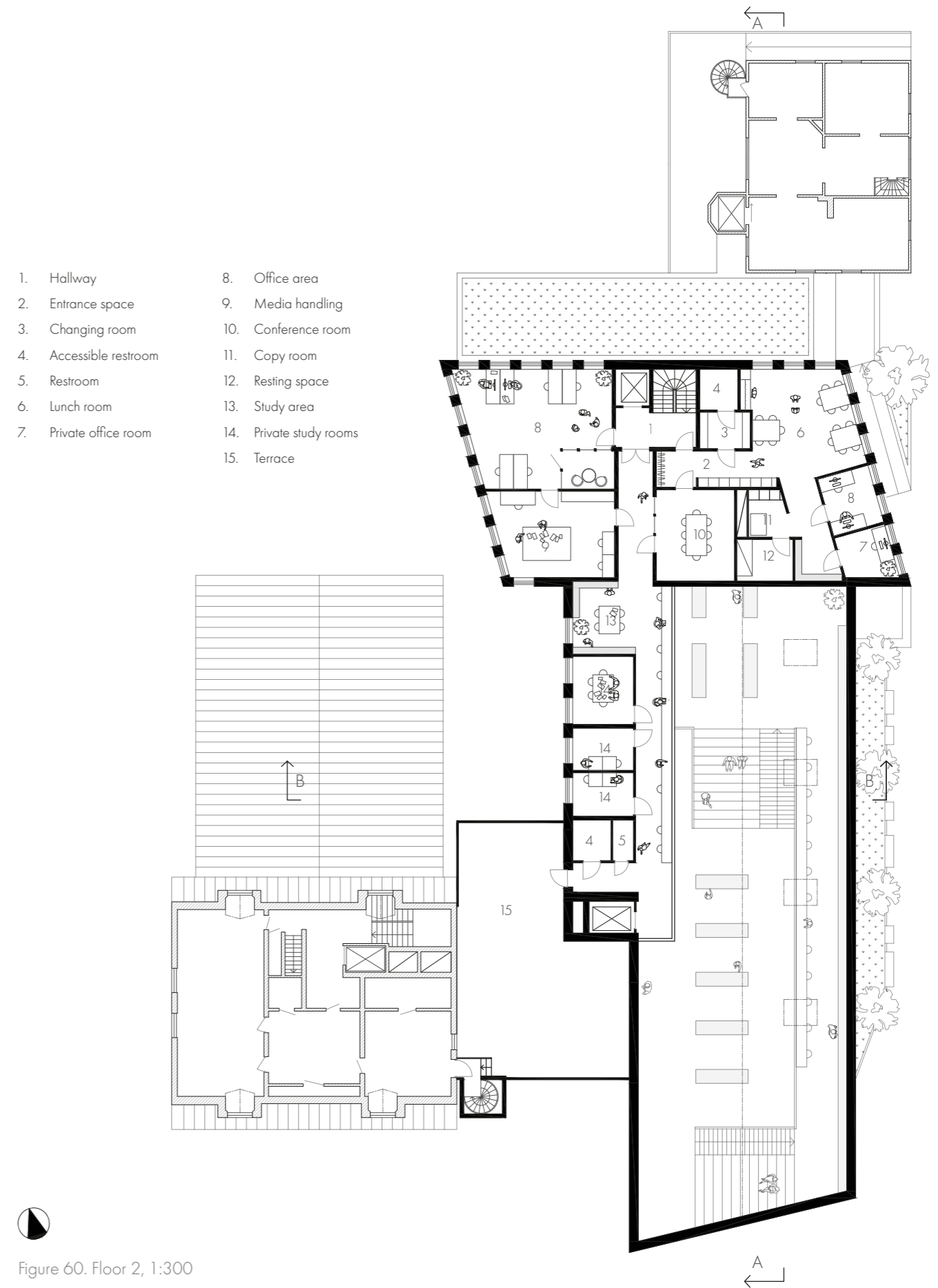

Figure 60. Floor 2, 1:300

A living room for Ulricehamn

A meeting place for the city

The main space of the building housing the library intends to become the new living room for the city. It houses a new library and connects to all the additional functions of the centre. The space becomes the primary arena for low-intensity meetings in Ulricehamn, a place everyone in the city can visit and use, while the additional spaces surrounding it are more focused on high-intensity meetings as a complement.

Together, the various functions allow the building to create meetings of many sorts for the people of the city. It also generates interaction between the actors that occupy it and creates a stronger link between them and the running of the city through multiple third places.

The steep, pitched ceiling is one of the most important aspects of the space, giving it the open and light quality, further accentuating the directionality of the building.

Overview between functions

The open nature of the space allows for visitors and staff to quickly grasp what is going on in the library and where to find things. The strongest connection is between the ground and first floor connected by two large stairs. Reception desks are located on both levels, making it easier for the staff to manage the spaces with the offices being located on the second floor.

The study shelf on the top floor is connected to the same space although more visually distanced, allowing for a calmer atmosphere than the main floors. Here one can sit with a laptop with a view towards the city below or the interior space of the library. It is connected to the other floors through elevators or a staircase at the centre of the northern volume. The offices are located next to the space allowing the staff easily to check the rooms if needed.



Figure 62. The main entrance connects directly to the City Hall, creating an open entrance to both institutions.



Figure 61. View of the main library space towards the south as seen from the first floor.



Figure 63. The calmer, more secluded study shelf on the second floor offering private study rooms and an open space.

Generating meetings

The building creates the possibility of low-interactive meetings to occur as many groups inhabit the same space. It additionally allows for the actors to interact with each other and the people of Ulricehamn in new ways. Some examples of this are:

Fika with a politician

Every month, there is a fika session in the main space of the library where people can come and talk directly to the people running the city. Questions can be asked and even if not joining the event, people in the library can recognise the politicians better and feel less distanced from them.

Workshop session on the city development

In addition to a more traditional citizen dialogue, the City Hall can make use of the new spaces to have sessions where people can sketch and showcase ideas in more creative ways to make themselves understood. This could be done together with the Youth Centre or Culture school and enable younger people to make their voices heard as well. Workshop sessions together with the politicians or civic servants could be a way to both showcase ideas and create bridges between the groups.

Open culture days

In 2022 Folkets hus, the Youth centre and Culture school had a common open house evening, an event which could be further expanded with the new development. This would be an opportunity to easily showcase a larger part of the cultural scene of the city and for the cultural school to exhibit and perform work to a larger audience while showcasing the broader cultural cluster created together with Folkets hus.

Exhibitions

Activities that would generate more low-intensity meetings would be the showcase of various work at the centre. It can be creations from the Cultural school, Youth centre or other actors. The venue simultaneously allows the City Hall to inform the inhabitants on plans or political motions. Zoning plans could be exhibited to keep people in the city updated on future projects and the arena would allow for inhabitants to get informed without actively having to search for the information, allowing the municipality to have an even stronger information channel towards its inhabitants.

Interaction between creator and consumer

This also allows the centre to become a natural meeting place between cultural creator and consumer, allowing people to meet in the real world and not only see each other's work through a screen. Performances in the Black box or at Folkets hus are additional ways of creating this connection.

With the library being a place more people visit than the other actors, the exposition of them through the building can lead to people becoming interested to try out new things and being aware of things they did not know before.

With the space inviting other actors to use the space as well, it can gradually become a hub not only for the highlighted actors but other private and non-profit associations. Eventually it can become the primary meeting place for the city, allowing all actors to be connected and becoming the physical manifestation of the small city where everyone knows everyone.



Figure 64. Fika with the local politicians is a possible activity in the building to create meetings between groups.



Figure 65. The building allows for low intense meetings through visual connections while avoiding disturbance through noise.

Housing the actors

The designed is based on the actors and their activities. Following is a description of which parts of the building are used by them.

The library occupies the main space of the building across all floors and partially some of the spaces on the second level together with the youth centre and other actors. The studio spaces and Black box on the ground floor are also shared with other actors, allowing for the cultural production to not be limited to the Culture school but available to a larger group, enabling more participation.

The City Hall gets a new reception together with the library, which becomes a citizen office. Meetings with the municipality and other agencies can be carried out in conference rooms located in the existing building in direct connection to the new. This makes this contact more approachable, strengthening the participatory part of the democracy and puts the meetings on more equal ground between politicians, municipality, agencies and citizens.

Other parts of the centre are used for the direct communication, where the library space can host fika sessions with the local politicians, allowing for citizens to meet them in smaller groups or one on one for more direct communication. The studio spaces can be utilised for workshop sessions, allowing for additional ways in which inhabitants can express their opinions.

The culture school gains new spaces for their non-music classes through the studio spaces and Black box. It collects them in one place and allows for further expansion into subjects such as music or podcast production through a new music studio space.

They can additionally make use of the event/exhibition space to showcase their material in the library and for events not hosted in the Black-box Theatre. Larger performances can be hosted in Folkets hus across the street, allowing for much larger audience numbers.

The youth centre gains a flexible addition to their building through the event/exhibition space and youth section. With spaces being added through the culture centre, no new dedicated construction for the youth centre is required. A benefit from adding to the existing space is that it keeps the sense of comfort and established third place that would be lost if they were to move to fully new premises.

Folkets Hus gain from an added cultural presence close by and a possible closer cooperation with the Culture school and Library. They become a part of a cluster of culture together with the other actors, offering a broad range of activities to the inhabitants of Ulricehamn.

Other groups and individuals in the city can additionally use spaces in the building when not occupied by the main actors of the centre, allowing for private pottery classes, meetings, performances for schools and other events.

Figures 66 - 69 showcase the primary spaces used by the actors, although they are free to use any of them when required in scenarios as described previously.

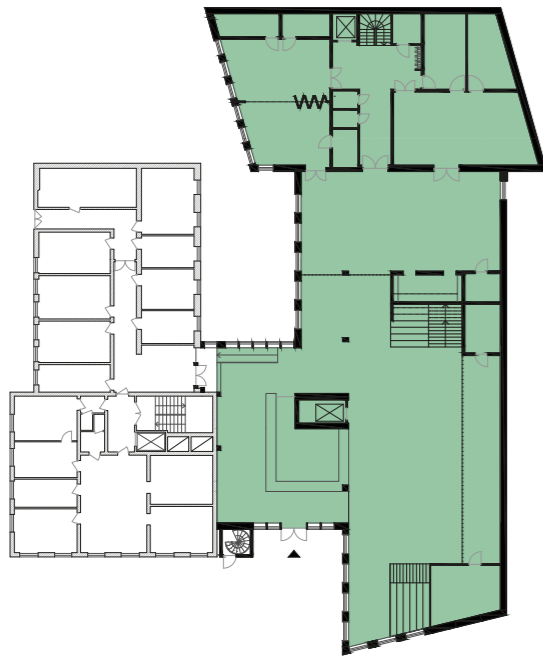

Figure 66. Areas of Floor 0 used by the library.

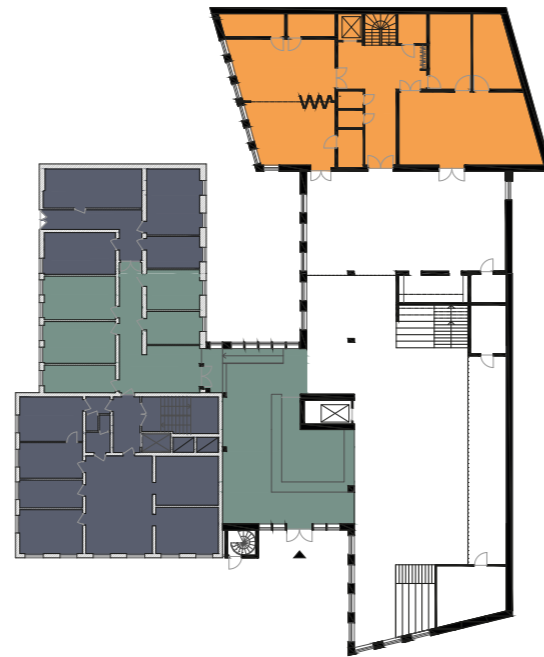

Figure 67. Areas of Floor 0 used primarily by the City Hall and Culture school.

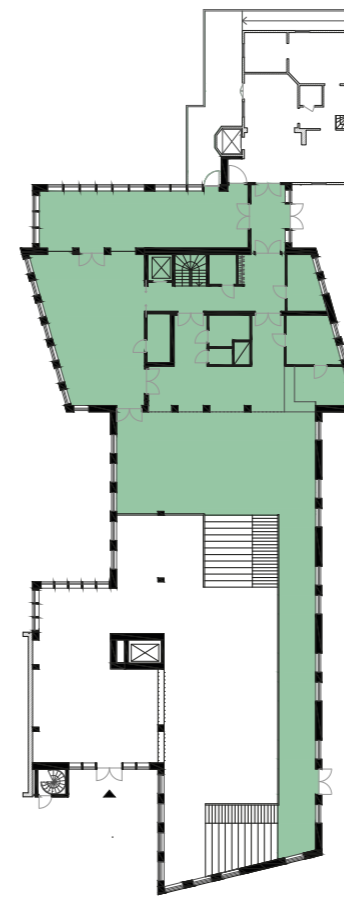

Figure 68. Areas of Floor 1 used by the library.

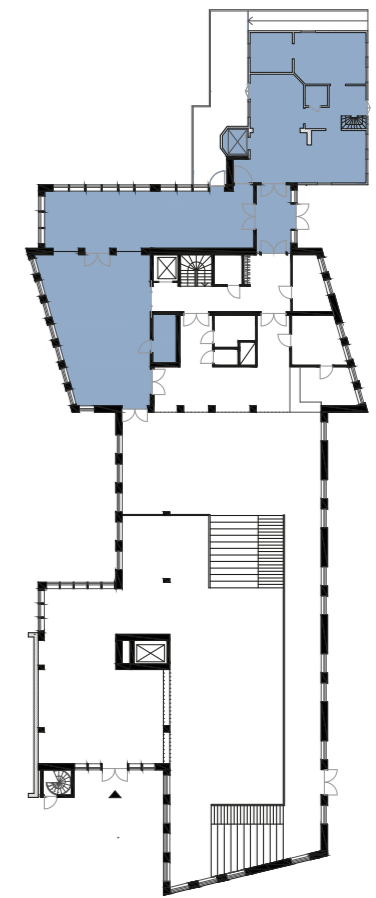

Figure 69. Areas of Floor 1 primarily used by the Youth centre.

A day in the cultural centre

To showcase how the spaces will be used is an example day of how the actors use the building.

In the morning, the library is open together with the City Hall. Meetings are taking place in the conference rooms and the studios are used by an external association. The drawing class at the Culture school is on the final day of exhibiting their work in the event space on the first floor for the public.

In the afternoon, the culture school classes are starting, and the exhibition is being taken down. The Youth centre

is open, and the youth section of the library is occupied by them for the rest of the day.

In the evening, the Youth centre has expanded fully, also occupying the event space and being at max capacity. At the same time, people are passing through the secondary entrance to watch a performance by the theatre class in the Black box on floor below.

The top floor is used only when the library is open and is therefore not included in the diagram below.

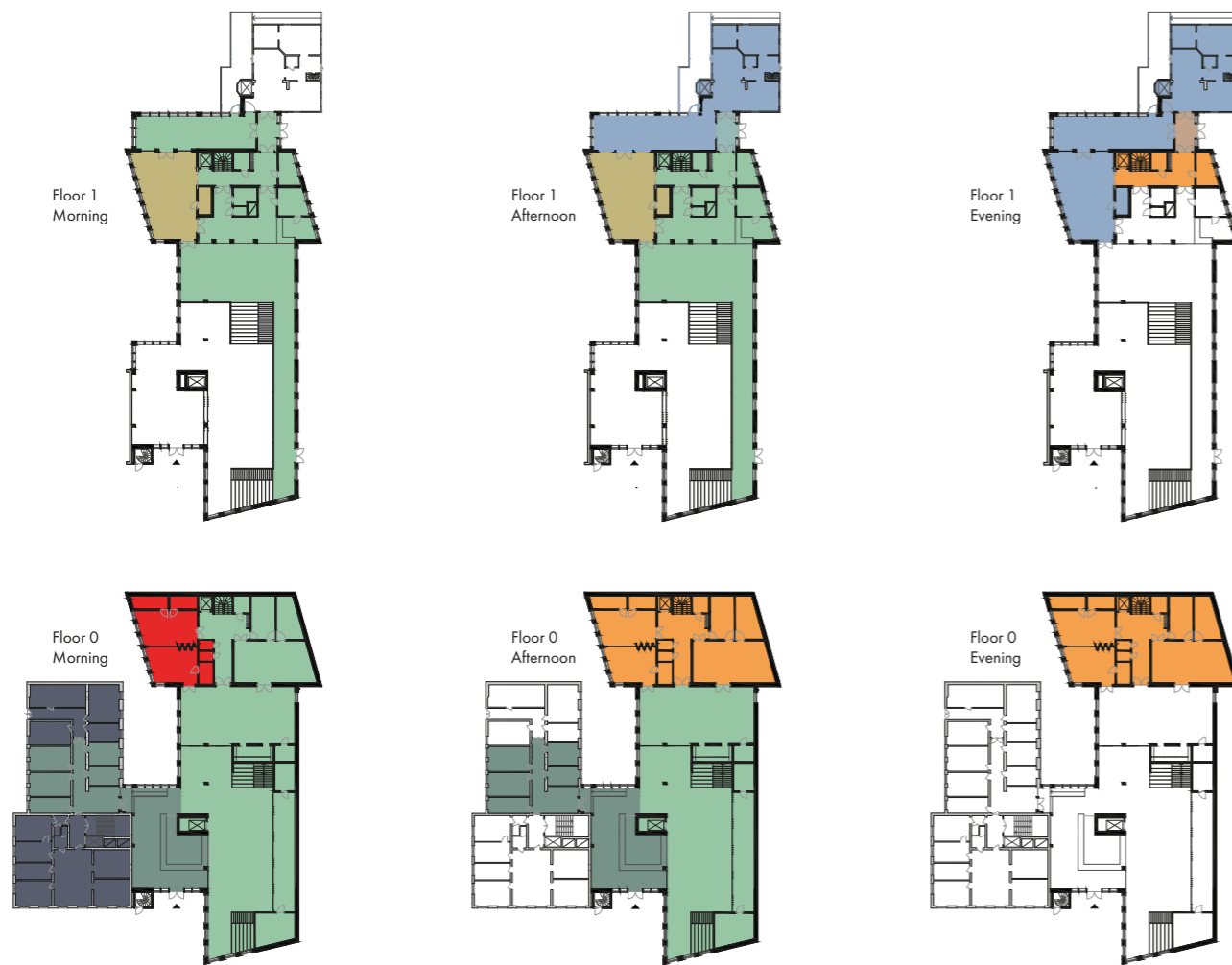

Previous page: Figure 70. Diagram of hypothetical usage of the two main floors throughout a day.

Above: Figure 71. The main space of the library as seen from the southern end of the ground floor. The height of the space allows for work to be exhibited within the space, a possibility for the other actors to gain exposition through the library.



Figure 72. View from the children's library.

Sections

Construction

The building is a wooden construction with a glulam construction and cross laminated timber interior. A detail section of the wall construction can be seen in figure 73. The roof is pulled together by steel cables, allowing for the full volume of the library space to be seen.

On the study balcony, there are diagonal beams pushing the horizontal forces down towards the load bearing facade since the weight of the roof does not land in a wall above that part of the building. These can be seen in figure 63.

Ventilation

The technical spaces are in the attic of the northern volume, reaching the spaces through a shaft. Some parts of the building have suspended ceilings, allowing for the ventilation to be distributed throughout the building, which can be seen in figure 75.

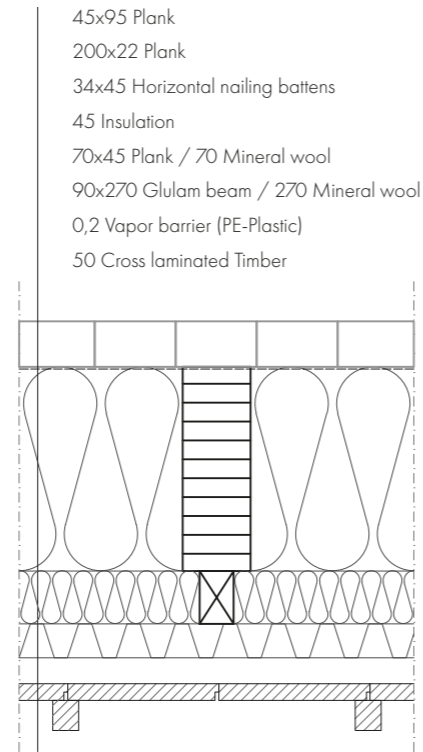

Figure 73. Facade detail, scale 1:10

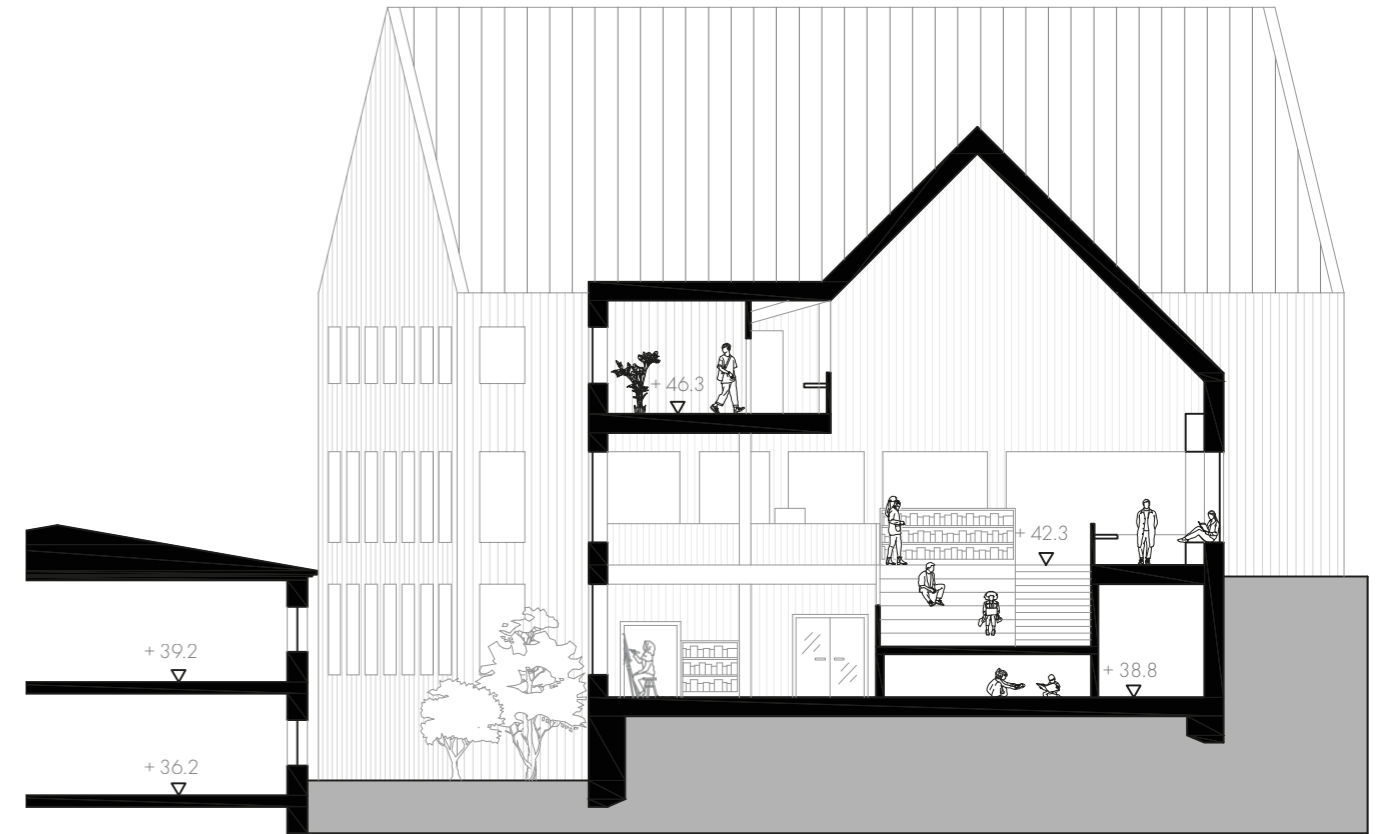
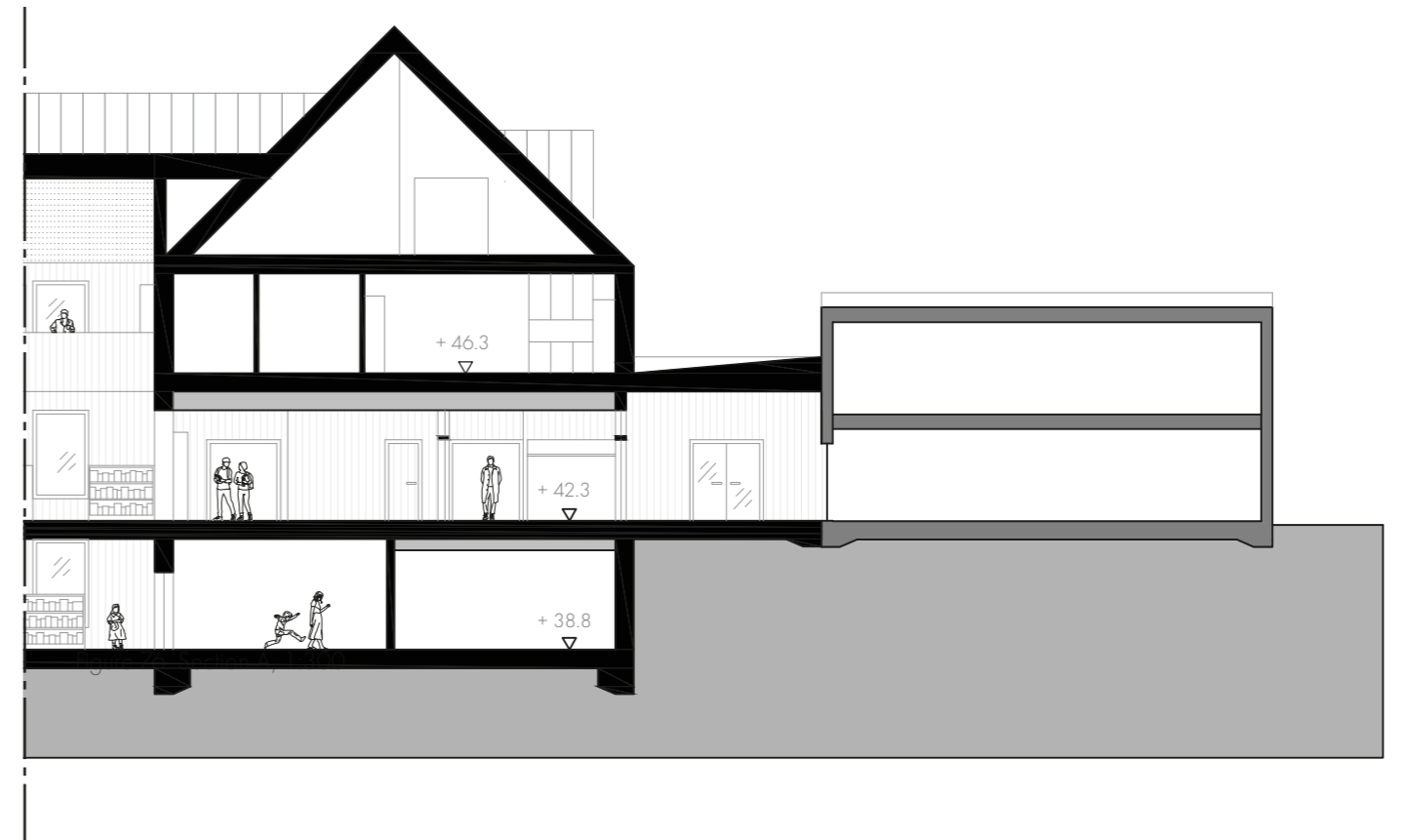

Figure 74. Section B, scale 1:300



Figure 75. Section A, scale 1:300



Design principles

Based on the Investigation, Theories and findings from the Design research, design principles are formulated to lift important aspects in creating the democratic arena that the project aims to.

An approachable building

For it to invite the people passing by, there needs to be an openness to the building so that one can see what is going on inside, creating an expectation. It is about not building barriers to enter the building.

An aspect of this is the scale of the building. If it mixes well with the surroundings and does not feel too big, it will also be a more approachable space and one that will feel more homely. This ties into the connection to the City Hall and creating a space where that interaction can become less daunting.

The materials used also influence how people will perceive it. In the proposal, wood is used as it is more associated with traditional housing than large, public buildings in the city. It takes more inspiration from the barn than the brick building.

The most highly occupied spaces in the building should be the ones that are the most visible. If things are happening and the spaces are active, the building will feel alive and welcoming. This allows for the building to expand and contract its active space while never feeling empty.

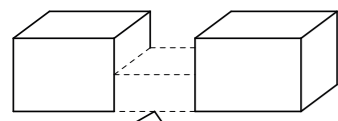

Figure 76. Managing the scale of the parts met by the visitors to create an approachable building.

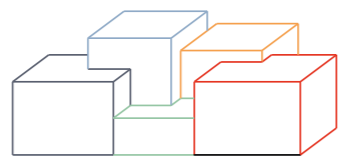

Figure 77. Grouping the actors together in one building will allow it to make use of each of their qualities in order to create a third place.

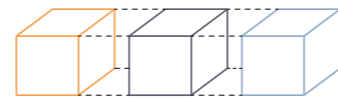

Figure 78. A large enough size and storage will allow one space to function for more than one actor.

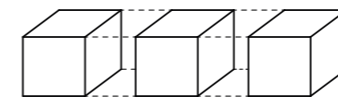

Figure 79. The connections between spaces become important in order to create overview.

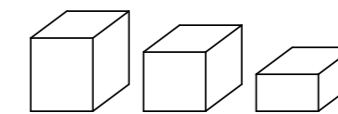

Figure 80. The way in which the building volume relates to the City Hall will be central to the hierarchy between them.

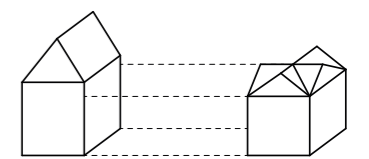

Figure 81. Creating something new which will still feel like a part of the existing cultural landscape will be the method in which to honour it.

Integrating the actors to create a third place

To create an open, democratic meeting place for Ulricehamn, the library should be integrated with the other aspects of the centre. Having activities to centre the meetings around create a larger incentive and allow for more than simple conversations in passing. Having the café as part of the library space will strengthen its function as a third place, while the creative studios and youth section will allow for more focused, high-intense meetings within the building. The conference rooms in the City Hall strengthen the meeting between people, cultural space and democracy.

Flexible spaces for multi-use and changeability

With the purpose of the building being to connect and house various actors and groups, it is important that there are spaces that are flexible to avoid creating a building that is larger than necessary and where the low-intense interactions don't happen since the groups do not move in the same spaces. It is also about creating a cultural centre that will be relevant in the future, when the needs are something else.

For this to work in practice there needs to be enough storage connected to the spaces that are supposed to be flexible, so that they can easily change content and occupancy. With the focus on cultural production that comes with culture 3.0, space will be required for these activities.

Overview between functions

Both architects and librarians brought up this as a central aspect during interviews. If there is a visibility between spaces, it will be easier for the staff to manage the building without having to walk around between levels to check. It is good for people visiting to get an overview of what is happening, where there are people and what things are on offer. It creates a safe environment both for the people visiting and the staff.

It will also be important to create visual communication between the spaces used by other actors to strengthen the low-intense meetings created by the building. By housing various groups in one space, connected by the public library there will be an opportunity for a strong arena for this kind of meetings. With the cultural school passing by the Youth centre, visitors to the library seeing aspects of the City Hall, people can become more aware of what goes on in other social contexts.

Hierarchy

An aspect of the design is to not make the cultural centre feel like a subordinate of the existing City Hall structure, but a new addition that is equally as important. The cultural centre becomes a building for the people, and with the inhabitants being who the municipality work for, this should be reflected in the connection between the buildings.

Reacting to the cultural heritage

Both the City Hall and many buildings on Nygatan hold a high historical value and have features characteristic of different periods of the city history. The new building should speak to the heritage but reimagine it in a modern context as per the theory of Cultural landscapes. It is about highlighting aspects of the surrounding cityscape and being a part of it while creating something new.

This creates a cultural centre that does not stand out by an altogether different volumetric language or expression, but by interpreting the cultural landscape into something new.

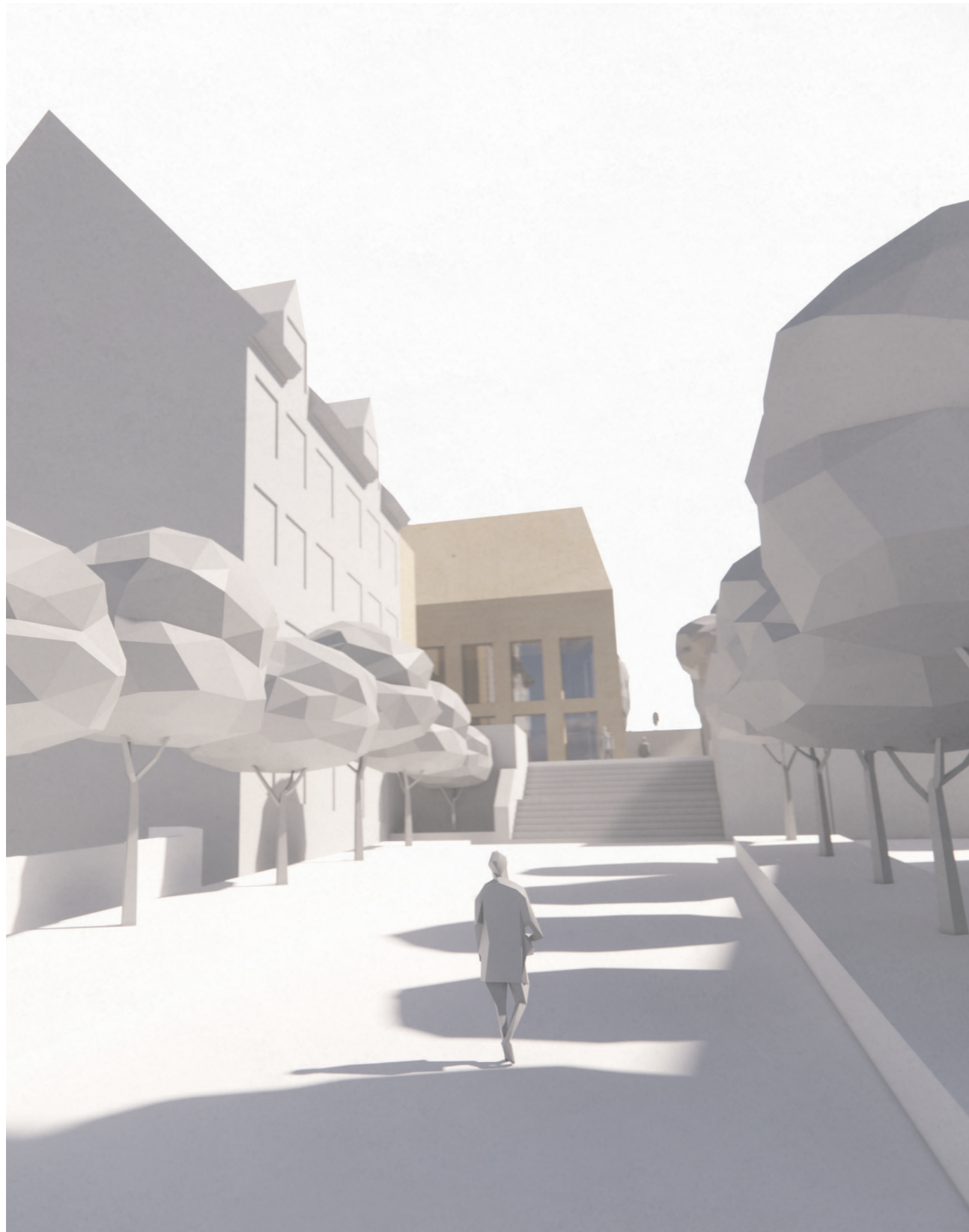

Figure 82. View towards the main entrance as seen from the western end of Rådhusgatan.

Discussion

Discussion

Conclusions

Reflections

Reference list

Acknowledgements

P. 81-92

Discussion

A representation of cultural importance

The hierarchy between the new building and the City Hall can be seen as a representation of the same struggle between public culture, political and municipal parts of the democratic process. These are all fundamental aspects of the democratic society. It does not function without a governing body of elected officials and civic servants to carry out the running of the city. At the same time, a democratic society rests on a foundation of access to knowledge and equal opportunities in learning, meeting and feeling part of larger whole.

The building standing tall over the City Hall additionally speaks to the hierarchy of power. The inhabitants decide who represents them as elected officials, and their opinions and ideas are at the base of the city democracy. With the focus on the age of culture 3.0 and allowing people to take part in culture in new ways, the connection to the City Hall not only allows for people to express their voices but additionally giving them an arena where they matter and can make a difference.

The two buildings both carry significance and from the outside become greater than the other depending on where one looks at them. From the city centre where the City Hall has stood tall as an Icon for decades, the cultural centre is mostly hidden, allowing for the brick tower to continue being the dominant part of the identity of that place.

The cultural centre becomes a motif further north in the city and from Nygatan above, with the true significance in the interior space. The building is in that sense a representation of the struggle Ulricehamn is going through right now with a lessening of the importance of culture from the side of the politicians, as the process of a new library continues.

In connecting to the cultural landscape, the architecture of the building in many ways mirrors the use of it. The

plan is built around connecting various actors and creating spaces that are not exclusive to one but useable by many. In a similar way, the architecture of the building has an identity that does not tie it to any single other institution but connects to many. It connects to the various architectural identities of the context while not fully being a part of any single one, just as the interior spaces of the building. It is an important representation of the building's nature. It does not belong to one actor, but all of them and all of Ulricehamn. It is a true third place in the sense that not only any one person, but any group or actor is welcome to share and use its spaces.

Not damaging existing actors when making additions

The cultural life of a city thrives on variety and enabling of both professional and amateur production. Through giving larger opportunities by opening new space for production, more people can take part in learning new skills. More participants will make the cultural sphere of the city grow and the interest will follow, benefiting the existing actors.

Through connecting to existing buildings, the project does not remove the space of the actors today but gives them an alternative to grow into a new, common arena. The youth section of the library can still function if the Youth centre were to move away into new premises, and the spaces currently used by the cultural school would not disappear as a result of the cultural centre. It is important that the new development does not block the further development of the actors as the city grows, since they could need more space further down the line and outgrow the building.

Using existing spaces of the City Hall and Youth centre and building upon them keeps a sense of familiarity at the same time as a new start, while allowing for growth. For the library, using the current ones is not a viable option and the spaces used by the Culture school outside of their music education are not their own.

Affecting the buildings on the site today

A risk when adding development next to buildings that are an important part of the cultural landscape such as Folkets Hus and the City Hall is the diminishing of their architectural qualities. Regarding the City Hall, as with the theory of cultural landscapes, the proposal aims to celebrate its qualities through an adaptation of them. Copying the style and making a direct extension to the buildings would have lessened the architecture by taking them out of their historic context, while the interpretation creates a style that could become the blueprint of public architecture in the city of Ulricehamn and therefore making it more central to the spatial identity of the city.

With the connection to Folkets hus the choice was to relate to it but not try to create something which reflected it. Making a space of two grand facades facing one another on Nygatan would have disturbed the balance of the street and

lessened the quality of both existing and new structures. The project aims to create a cultural hub where Folkets hus is a part of it and should not be seen as something altogether separate. The spaces in Folkets hus should be seen as another aspect of creating the third place and generating social capital. Therefore, the building can be allowed to take a dominant role in this space. The aspect of creating an approachable building also utilises this as the new development in its placement opposite the existing grand facade can be perceived to have a lower profile, while the event-based nature of Folkets hus can have a more high-profile exterior, reflecting that which is happening there.

Finally, as mentioned by Mellano (2017), a city changes and grows. One cannot be too afraid to make interventions in the historic landscape or the space will be stuck in the past. What is important is intervening with care and honouring the qualities of the existing structures.



Figure 83. The new building connecting to the Youth centre at the back lessens the impact on the existing structure as it retains its independence against the street while being a part of the centre through creating the protected entrance niche.

Making a statement through specific features

The project mostly works with smaller gestures on the exterior to guide and symbolise. A few things are allowed to be grander gestures since they carry larger symbolism and function. The roof is one example of this, where it becomes a dominating aspect of the architecture, both on the outside and inside, creating a very strong identity for the building. It leans on the City Hall and creates a model for the public architecture of Ulricehamn.

The other larger gesture is how the building interacts with Rådhusgatan. It extends quite far out into the existing street and blocks a large part of the existing view. It does however still allow for a slight line of sight past and a glimpse of the view below when coming from above on Rådhusgatan.

The reason for the occupation of the space is to create a stronger emphasis on creating a square in front of the building, which together with the upper part of the main square create a larger, open space. The interior part is where one of the two larger staircases are, and the extension allows for this space to have a view of the city below. The interior and exterior stairs mirror each other and therefore the passage

is as wide as before, with the path divided between exterior and interior public space.

The gables being angled, which comes from this historic feature found on the street allows for a slightly softer meeting with the building. The centre breaking the existing movement path creates a harsh stop, where the angle of the gable allows for this to ease. It is about the balance of stepping out far onto Rådhusgatan and at the same time creating natural movement. When approaching from below, one steps up on a new level and naturally takes a break, allowing for the building to make a larger step out into the path.

The other gables of the building are angled, becoming a part of the building identity. It is used to direct towards the secondary entrance as well, while allowing for the building to touch the edge of the sidewalk where the rest of the buildings on the western side of Nygatan stand. On the back, it is used to keep a distance between the new and existing building, to highlight the connections that are made. The slight difference to the flat gable of the City Hall allows the buildings to speak the same language of the public architecture, but still showcases that they are not one single unit.

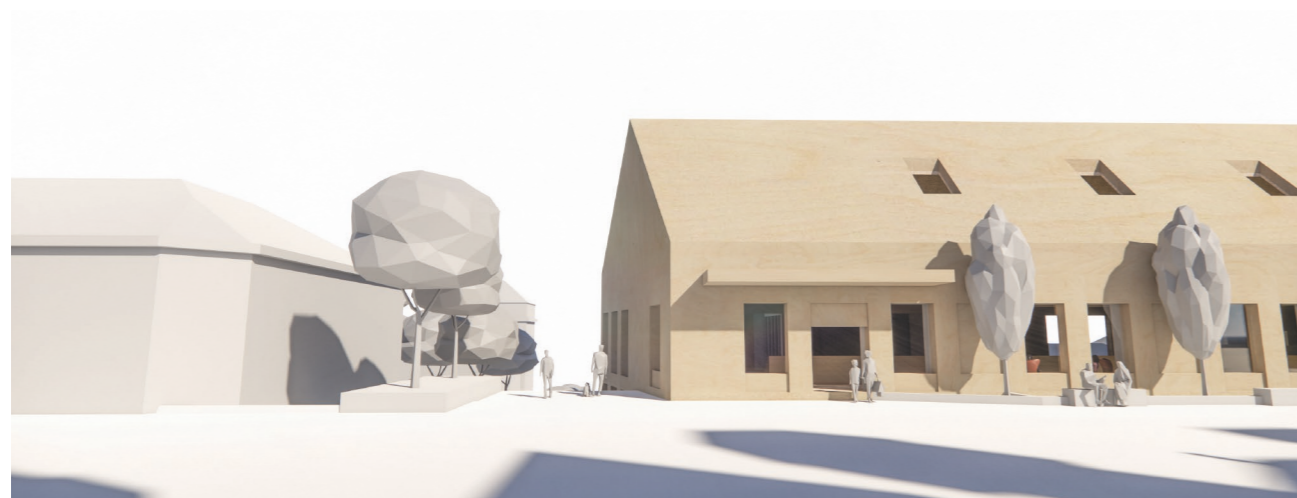

Figure 84. The building as seen from the east on Rådhusgatan. Showcases the way in which the building steps out into the sightline of the street.

The building as an example of connecting

The centre aims to be a third place for everyone, for the whole city. It does not however try to be the only third place for everyone. People will have other places in the city to meet and the project tries to enrichen the city.

While the space tries to be one where anyone will feel welcome, that is not the same as being one everyone will want to visit or have as their primary meeting place. Catering to every desire and need is not the aim and is not possible for any single intervention. Some people will want to meet in other ways, so the important part is about lowering the barriers rather than catering directly to all interests.

With the democratic side being an important aspect, it is relevant to reflect upon how those not directly interested in the culture would use the cultural centre and this interaction. While the spatial connection becomes direct between the culture and City Hall, others can interact as well. The cultural aspect allows for democratic interaction in new ways, but that does not mean other ways of meeting become less important. The City Hall can use the spaces separately from the cultural actors just as they can use them separately from the City Hall. The main topic of the project is that of culture as a tool for democratic participation and therefore this has been the focus. It does not mean that other ways of interaction with the democratic society are not possible or enabled.

It is also not a solution to every way in which the City Hall directly interacts with the inhabitants. It is as a way of showcasing how that connection could be made, with an architectural tool. But other connections are important to reach everyone, and the cultural centre is not the answer to them all. It is a start and could enable further discussion on how our democratic society will look like in the future.

Will there be ways to meet in the local restaurants and bars, activities at the schools or politicians visiting the meeting places for the elderly? A discussion needs to be had on how the different parts of society interact through these third places, as many already exist and can be utilised today. One does not need to create a grand new development in order to meet face to face and interact with one another, but it is a tool to showcase how those meetings can be beneficial in tangible ways to those involved. It is about using the opportunity provided by the need of a new library, to connect the third place to actors and create more value.

The project is about using existing actors to create something more than a new library or regular cultural centre. In the same way, the existing actors can be used in other settings, together with other groups and in existing spaces.

Changing Rådhusgatan

The intervention makes alterations to an existing public space and changes the visibility and movement paths. The upper part of Rådhusgatan changes in character as the visual connection to the city centre below is weakened with the Cultural centre reaching out, making the view more narrow.

The accessibility to the existing structures and between Bogesundsgatan and Nygatan is improved with the intervention. Today, there is a staircase as the only pedestrian path on Rådhusgatan between the lower part and the level where the parking space is. The intervention adds an elevator between these two parts, allowing for a much more accessible path. The slope upwards is partially kept as access for cars to the opposite building, allowing for access to the main entrance from Nygatan without any stairs. Passage past Rådhusgatan becomes easier and connects the existing buildings to the city centre in a more inclusive way.

Conclusions

How can the addition of a cultural centre enable stronger connections between public and cultural actors, creating a new, participatory democratic space in the context of Ulricehamn?

With culture as a method, new possible ways for citizens to interact with the democratic process has been explored in the project through the design of a cultural centre. A central theme is the use of established actors with a higher interaction with the inhabitants of Ulricehamn as a stepping-stone for democratic participation. When combining the spaces of the library and City Hall, the civic process is allowed to take place in an arena designed with the purpose of everyone feeling welcome. It simultaneously gives another dimension to the library as a meeting place with new forms of both high- and low intense meetings taking place through this connection. The civic society benefits from the conversation moving to a space where the citizens feel a larger ownership than that of the City Hall, lowering the barrier of taking part in it.

Ulricehamn has the potential as a city to both have a high trust in the institutions through a larger social capital at the same time as allowing for easy and direct communication between citizen and those in charge. Using the cultural centre would be one method of achieving this and how the new city library is designed will have a big impact both on the social fabric of Ulricehamn but also the democratic participation.

How can the cultural centre act as a third place in the city of Ulricehamn?

The cultural centre in many ways transcends the concept of a third place. The individual actors alone might not fulfil all the aspects of the term, but as a cluster they collectively do more than that, highlighting the strength of cooperation and connection between them. Collectively they create a multitude of ways to interact and meet others, not only for inhabitants but groups and actors, working as a third place in a broader sense and being a place where everyone can participate in a way suited to them.

How does a cultural centre remain relevant in the future, with a constantly changing cultural landscape?

A part of the relevance for the future is the spatial aspect of the centre. Having flexible spaces that can change with new needs and desires is important for it to be relevant in the decades to come (Wiksfors, 2019).

More importantly however, is the social and participatory aspects of the activities and actors that make up the cultural centre as they are the core of the project, and the building a tool for them to function in the best way possible. The participatory culture 3.0 that is described by Sacco (2011) highlights the blurring line between creator and consumer of culture as new digital tools enable creation for more people. In this future, giving a meeting place for creators and consumers to meet in a physical medium could become a more prominent function of the cultural centre as a space, allowing it to continue being important however the mediums of culture change.

Reflections

Social capital as an existing strength of Ulricehamn

Another aspect of creating a democratic meeting place is the low-intense arena of participation for creating bonding social capital between groups and social classes in a society. Here, the physical connection of the actors becomes paramount to avoiding the risk of creating barriers that high-intense meeting places can create as mentioned by Audunson (2005). Exchange between these actors, common events and cooperation becomes easier as they are part of the same setting, while allowing these to additionally create low-intense meetings through proximity. This is a way to enable social capital between groups and the basis for trust in a society as described by Aabø, Audunson and Vårheim (2010).

The existing connections between actors in Ulricehamn sets it apart from larger cities and with the plans that were in the making at the start of the thesis with a new library at ICA by the lake, this would not have been prioritized in the same way. It would have generated a better meeting place through the library than the one existing today, but focused on the spatial strength of Ulricehamn as a city by the lake rather than the social strength of existing bonds and a short distance between people, actors and the municipality. This is something specific to the context and which cannot be transferred anywhere else. It is about using the existing social capital as a strength to create a democratic arena only possible in the context of Ulricehamn.

Feasibility of the desired results

The project has tried to showcase ways in which new and existing connections between actors and citizens can be strengthened to create a space for culture and citizen participation. Many possibilities have been found of ways in which the cooperation between institutions could create value for the people of Ulricehamn through an architectural

intervention. The main addition that would lead to the democratic arena is not only the spaces added by a new building, but the way in which they are occupied and used by the actors they are made for. As the project is hypothetical one cannot know exactly how it would work in reality, if the spaces would be used in the way intended, or not generate the wanted values. As a limitation by the time available, the actors were not able to take part in the later stages of the design process which would have given a more nuanced proposal in terms of these aspects.

This is a part of the method that could have been done more thoroughly with more time. It would have been interesting to see the project taken even further through including the local stakeholders in a later stage of the process than was possible as the project is centred around the connections between people and actors as much as the building itself.

Having time to make a broader cultural mapping of Ulricehamn would have given further depth to the design and a more inclusive approach, as it only focuses on the public actors. If fully applied, this methodology would have given a very strong foundation for a continued discussion with the stakeholders, and continued inclusion of the actors would have been the main way for the project to expand and become more nuanced.

In the same way as with the connections, the aspect of a meeting place is something which one cannot know how it would work. If the low-intense meetings take place is something which can be encouraged but not forced and would have to be seen if it came to fruition. To in more detail study the use of cultural centres would be an interesting addition to this, in order to see a feasibility to the theoretical discussion.

With this said, the project showcases possible ways for architecture to help foster interaction between parts of a society with the hope of it adding to the discussion taking place and allowing for new ways to see both the problems but also opportunities being faced by the need of a new city library in Ulricehamn.

Beyond the term of third place

The three aspects required of a third place discussed in the literature analysis that a library often does not fulfil are those of conversation as the main activity, having a lively, playful mood and keeping a low profile. Of these, the third is addressed architecturally as discussed earlier regarding the design principle of an approachable building. With the taller parts turned towards the back of the building, the facades people meet close up are allowed to have a lower profile and be smaller in scale.

If looking solely at the library, the other two aspects might not be fully realised as the playful and lively mood might not be fulfilled. However, as with the rest of the project, the question is not to be answered through the lens of one individual actor. Both the Youth Centre and Cultural school will have more lively moods and conversation as more central aspects of their activities. Additionally, the library as an arena will invite for conversation as it is used by the civic part of the society, filling that aspect through the connection.

The library as a place has aspects that fit the category of a second place (school or work) or first place (the home). It is by many used to study and for activities that would be better designated to the second place. (Aabø & Audunson, 2012) The youth centre could additionally be seen as a partial first place for some, an escape from a crowded or unsafe home, where one is more comfortable together with others of the same age.

One aspect that sets the centre in the specific context apart and makes it more than simply a third place is the symbiosis of culture and democracy. That it not only allows for people to learn new skills and create, but to use this as a tool for being part of the democratic process. Making their voices and opinions heard, and becoming an arena where the people not only have power in what is created and exhibited in the cultural sphere, but a direct conversation with the political and civic spheres of the city being able to take place in the same arena. In this sense, culture 3.0 will allow for the space to be the democratic meeting place of tomorrow and keeping relevance through the application of participation as much as the act of it, going beyond the democratic aspect of a traditional third place.

Remaining relevant

The traditional library where the main task is to provide books and other forms of information is becoming less relevant. In the future, the library as a meeting place where the main activity is that of conversation will become more important. The thing which will set it apart from all that is available in the future is the physical meetings and connections it can provide. The way to remain relevant is not to think what a library or cultural centre should be and has been, but rather what it could be and what people will desire from it in the future. Participation and meetings are the two main aspects of this.

Method

The project was an iterative one where the results from the chosen methodologies informed the decisions made in the design process. The literature studies gave an understanding of aspects relevant both to the design of the building, but also the underlying social aspects important to relate to in a public building. These insights have led to specific design choices, and the level of depth to the design evolved with my understanding of the subject.

In the same way, the design process informed the methods as the process progressed. As I came further in the project, my understanding allowed for more specific questions and finding further relevant material and reference projects for what the product would end up becoming. The design also opened a wider discussion as the connections between culture and democracy became more concrete with the building.

Final thoughts

What I wanted to show with this project is a strength found in Ulricehamn and how it could be applied on the future development of the public institutions of the city. It is not about giving a definitive answer of how to design the new city library, but rather a discussion of what is possible in the context to create something that generates value for more than just the library. How the cultural arena can create a place of knowledge, go beyond the third place through creating a wide range of possible meeting places and allow for people to not only take a larger part in creating culture and sharing it with others, but use the forum to take a greater role in shaping the society they live in.

The interaction between culture and civic society is something which could benefit both sides and the whole democratic foundation of a society. Ulricehamn as a context has good conditions in place to make use of this, with a replacement of the city library an opportunity to do so. The project started out with this thought of replacing the library and creating something wider through a cultural centre, providing more value for the city. It ended up discussing questions about the interaction between democracy and culture, but also the many ways in which the cultural space can create meaning.

The project centres around the two topics of culture and democracy. These are both very relevant and culture has become a hot topic lately regarding if politicians should be distanced from it. Recent events such as Drag queens

reading for children is questioned by some politicians and on a larger scale, tendencies can be seen towards a larger influence from politicians on what the public culture should contain.

In this project this connection is discussed in many ways and this aspect is relevant as well. By bringing the two together spatially, I do not see it as leading to a higher control from the politicians. They do not gain more authority by suddenly being a shorter distance from the culture and life of the city. I would rather argue that the action leads to culture potentially gaining more power through influence. By positioning them together, people from the politics and municipality can gain a greater understanding of the public culture and what it represents.

Often, the things people are afraid of are from a lack of knowledge and understanding. So it becomes even more important in this cultural centre to have a space for everyone, both that which may seem harmless and that which sparks discussion. Expressing opinions and talking about them is central in a democracy, and the core of the low-intense meetings discussed in the thesis is to create understanding and can also be applied on the people making the decisions. If they see that which they are against, if it becomes more difficult to evade, they might start to think in new ways and broaden the discussion of what culture should contain and express.

A large part of why society is diverging, and people are becoming more distant is from not being exposed to those with other opinions and views. Social media has made it easier to live in social bubbles where everyone agrees and therefore, the number of low-intense meetings we have are decreasing as a result. It is therefore more important than ever, that these spaces are created and have a part of our cities. Making it more difficult to completely evade those who are different and think in other ways, could make it harder to use the narrative of us and them.

References

Aabø, S., & Audunson, R. (2012, April). *Use of library space and the library as place*. Library & Information Science Research, 34, pp. 79-156. doi:<https://doi.org/10.1016/j.lisr.2011.06.002>

Aabø, S., Audunson, R., & Vårheim, A. (2010, January). *How do public libraries function as meeting places?* Library & Information Science Research, 32, pp. 1-96. doi:<https://doi.org/10.1016/j.lisr.2009.07.008>

Topo Arkitekter. (2022, February 09). *Nya Stadsbiblioteket*. Ulricehamn: Ulricehamns Kommun.

Audunson, R. (June 2005). *The public library as a meeting-place in a multicultural and digital context: The necessity of low-intensive meeting-places*. Journal of Documentation, 61(3), 429-441. doi:<http://dx.doi.org/10.1108/00220410510598562>

Bergquist, E. (2012). *År framtiden kulturens re-renässans?* Stockholm: Statsrådsberedningen.

Cobe. (n.d.). *The library*. Retrieved March 27, 2023, from Cobe.dk: <https://cobe.dk/place/the-library>

dac. (n.d.). *Biblioteket, Rentemestervej*. Retrieved March 27, 2023, from Danish Architecture Centre: <https://dac.dk/en/knowledgebase/architecture/biblioteket-rentemestervej-2/>

Dahlberg, Å. (2013, December 2). *Läckage i biblioteket hotar samlingar*. Sverige Radio.

Egeland, H., & Johannisson, J. (Eds.). (2003). *Kultur, plats, identitet : det lokals betydelse i en globaliserad värld*. Stockholm: SISTER.

Eldås, L., & Carlsson, F. (2022). *Kommunkompassen Ulricehamns kommun*. Sveriges Kommuner och Landsting.

Erickson, H. (2021, September 4). *Miljonrullningen kring nya biblioteket är en skandal*. Ulricehamns Tidning.

European Task Force on Culture and Development. (1997). *In from the margins : a contribution to the debate on culture and development in Europe*. Strasbourg : Council of Europe.

Frick, E. (den 9 February 2023). *Tour of Folkets hus*. (J. Sidenvik, Intervjuare)

Ghilardi, L. (2017). *Making the most of Cultural and Creative Resources, The Mapping and Strategy Building Handbook for Creative Towns and Regions*. Culture and Creativity, EU-Eastern Partnership programme.

Hallemar, D. (2022). *Vindelns bibliotek*. In D. Hallemar, Folkbiblioteket (pp. 202-205). Malmö: Bokförlaget Arena.

Ingvarsson, V., & kulju, M. (2010). *Biblioteket som mötesplats - Vad menas med det?* Borås: Högskolan i Borås.

Istenes, J., & Larsson, F. (2011). *Bibliotekscaféet som place, En användarstudie om bibliotekscaféer på folkbibliotek*. Borås: Högskolan i Borås.

Johansson, A.-L. (2023, February 8). *Discussion on Library design*. (J. Sidenvik, Interviewer)

Jomaa, K. (2023, February 10). *Information and tour of Ungdomens hus*. (J. Sidenvik, Interviewer)

Kjellberg, I. (2019). *Med kulturen som (värdeskapande) hyresgäst*. Göteborgs Universitet.

Kulturdepartementet. (2018). *Strategi för en stark demokrati - främja, förankra, försvara*. Stockholm: Regeringskansliet .

Lind, M. (2023, January 30). *Discussion on Selma Lagerlöfs Center*. (J. Sidenvik, Interviewer)

Mellano, P. (2017). *Regaining the culture of cities*. City, Territory and Architecture, 4. doi:<https://doi.org/10.1186/s40410-017-0063-3>

merriam-webster. (n.d.). merriam-webster. Retrieved November 18, 2022, from <https://www.merriam-webster.com/dictionary/culture>

Ohlsson, E. (Ed.). (2022, January 7). *Ulricehamns Kommun*. Retrieved 10 13, 2022, from <https://www.ulricehamn.se/uppleva/sevardabyggnader/historia/>

Ohshima, Y. (2021, May 25). *Befolkningsprognos 2021-2030*. Ulricehamn: Ulricehamns Kommun.

Petrini, F. (2023, February 9). *Culture school in Ulricehamn*. (J. Sidenvik, Interviewer)

Sacco, P. L. (2011). *Culture 3.0: A new perspective for the EU*. EENC.

Seldevall, C. (2023, March 11). *Miljonrullning runt stadsbiblioteket men ännu inget bygglov*. Ulricehamn Tidning.

Seldevall, C. (2023, April 10). *Nytt stadsbibliotek – ett antiklimax för kommunen*. Ulricehamns Tidning.

Sleeman, M. (2012). *There's no home like place?* In P. Myers (Ed.), *Going home: Essays, Articles and Stories in honour of the Anderssons* (pp. 33-40). London: Oak Hill College.

Sweco. (2020, April 28). *A-40-1-113*. Gothenburg. Building permit retrieved from Gothenburg city planning office

Tal Federa, S. M. (2021). *Cultural consumption and Covid-19: evidence from the Taking Part and COVID-19 Cultural Participation Monitor surveys*. Leisure Studies, 42, 38-55.

Temple, N. (2012). *Prologue: Cultivating Architecture*. In P. Emmons, J. Hendrix, & J. Lomholt (Eds.), *The Cultural role of Architecture, Contemporary and Historical Perspectives* (pp. 19-28). London: Routledge.

Tjäder, A. (n.d.). *Historia*. Retrieved 02 23, 2023, from folketshusulricehamn: <https://www.folketshusulricehamn.se/historia/>

Ulricehamns Kommun. (n.d.). *Invånare och kommunfakta*. Retrieved November 14, 2022, from Ulricehamns kommun: <https://www.ulricehamn.se/omkommunen/samhalle-och-befolkning/kommunfakta/>

Vermelin, E. (2017). *Ulricehamns Stadshus, en stolt del av Ulricehamn sedan 1957*. Ulricehamn: Ulricehamns Kommun. Hämtat från <https://docplayer.se/69156167-Ulricehamns-stadshus-en-stolt-del-av-ulricehamn-sedan-ulricehamn-se.html> den 23 02 2023

Wide, J. (2017, December 05). *Politiskt deltagande i stadsregioner. Är kontexten könsneutral?* Statsvetenskaplig tidskrift, 119, pp. 521-541.

Wiksfors, Ö. (2019). *Framtidens Kulturlokaler*. In *Framtidens Fastighetsbehov*. Stockholm: Sveriges Kommuner och Landsting.

Figure references

All figures are the work of the author unless specified.

Figure 4: Jan Töve, *Photograph of Ulricehamn Main Square*, retrieved from Ulricehamn.se at <https://www.ulricehamn.se/uppleva/sevardabyggnader/>

Figure 7: Sweco. (2020, April 28). *A-40-1-113*. Gothenburg. Building permit retrieved from Gothenburg city planning office

Figure 10: Leandersson, B. (2022). Bokförlaget Arena. Retrieved April 11, 2023, from <https://magasink.se/2022/09/folkbibliotekens-olika-rum-fran-skrytbyggen-till-ombyggda-butiker/>

Figure 11: Hjortshøj, R. (n.d.). *Biblioteket, Rentemestervej*. Retrieved March 27, 2023, from Danish Architecture centre: <https://dac.dk/en/knowledgebase/architecture/biblioteket-rentemestervej-2/#gallery-1>

Figure 12: Hjortshøj, R. (n.d.). *Biblioteket, Rentemestervej*. Retrieved March 27, 2023, from Danish Architecture centre: <https://dac.dk/en/knowledgebase/architecture/biblioteket-rentemestervej-2/#gallery-2>

Figure 14: Holl, K. (2005, July 20). Wikimedia commons. Retrieved from https://commons.wikimedia.org/wiki/File:Scandinavia_1219.gif

Trafikverket.se. (n.d.). Retrieved March 23, 2023, from <https://gis.trafikverket.se/portal/apps/experiencebuilder/experience/?id=86609ec9541846899f57c35f9be1ce50&page=home>

Figure 17: Diagram based on data from: Ohshima, Y. (2021, May 25). *Befolkningsprognos 2021-2030*. Ulricehamn: Ulricehamns Kommun.

Figure 19: Google. (2022, July). *Stenbocksgatan 21 "Google streetview"*. Ulricehamn, Sweden. Retrieved March 29, 2023, from <https://www.google.se/maps/>

Acknowledgements

Thanks to:

My supervisor John for always pushing me and keeping my excitement for the project going.

My examiner Nils Björling for great insight during the process.

Rebecka Engwall, City Architect in Ulricehamn.

Fredrik Petrini at Kulturskolan Ulricehamn.

Anna-Lena Johansson, Head of Library and Culture in Ulricehamn.

Elisabet Frick at Folkets Hus Ulricehamn for giving me a tour of the building.

Ulricehamn City Planning office for maps and other material.

The staff at Ungdomens Hus for showing me around.

The people at my table in the studio for making the semester so much more of a joy.

Margareta Diedrichs, Mattias Lind & Per Uhlin for giving great insight and tips on the design of cultural spaces.



CHALMERS
UNIVERSITY OF TECHNOLOGY

Joel Sidenvik - Master Thesis 2023