



## A PLACE FOR THE MODERN FUNERAL

Using the unique properties of textile to create a new sacral architecture

Author: Anton Ekdahl  
Chalmers School of Architecture,  
DEPARTMENT OF ARCHITECTURE & CIVIL ENGINEERING, CHALMERS UNIVERSITY  
Course ARKX03, Master's thesis, Spring semester, 2014  
Examinator: Morten Lund  
Supervisor: Daniel Norell



# A PLACE FOR THE MODERN FUNERAL

Using the unique properties of textile to create a new sacral architecture

Author: Anton Ekdahl

Chalmers School of Architecture,  
DEPARTMENT OF ARCHITECTURE & CIVIL ENGINEERING, CHALMERS  
UNIVERSITY

Course ARKX03, Master's thesis, Spring semester, 2014

Studio: Matter, Space, Structure

Examinator: Morten Lund

Supervisor: Daniel Norell



**CHALMERS**  
UNIVERSITY OF TECHNOLOGY



## INTRODUCTION

Death is a natural part of life and something that happens to us all. The funeral is in a way the last thing we do before we only become a part of people's memories. It is a chance to celebrate the life that once was and together say farewell to our loved ones. It is therefore important to make it as easy as possible for the mourners in their vulnerable situation and create a building that enables them to give a personal farewell.

We live in a society with many different cultures, traditions and ideologies. It is therefore important that the modern funeral architecture can suit the needs of many different people, so that they can create their own personal funeral. For that to happen the building needs to be flexible.

In my project I have explored how such a building could be designed, without sacrificing its dignity. The classical sacral architecture often use durable materials like stone and bricks to give a dignity to the building. I want to explore what qualities you can achieve if you use a less common material like textile, a light and more fragile material, to create the dignity and the mood in the building.

The textile's ability to react to its surroundings of light, shadows and movement makes the material come alive, changing its appearance through the day and the seasons. It makes the visitors more aware of life around them, replacing the religious symbols with a universal symbolism. The diffused light and the soft movement of the textiles give a calm atmosphere to the building and a sensory experience, all together setting the mood for the funeral.

The building's main materials – textile and glass, creates an open and light building that deviates from the classic sacred buildings with their oftentimes heavy materials and secluded appearance. The glazed façade in combination with the textile lets the light in but at the same time creates a diffused transparency, making the interior more private and intimate. From the exterior you can sense something happening on the inside without it being too exposed to the public.

The neutral placement of the building, separated from the graveyard, and its closeness to the public transport node makes it more accessible and possible to use for other purposes, since it is not as closely associated with death.

# BACKGROUND

## STATISTICS

The population is increasing and so will the funerals. There is a noticeable trend of decreasing funerals in accordance to the traditions of the Swedish church. Civil funerals and funerals for people with other cultures are increasing and will probably keep increasing. Cremation is the most common way to take care of the body after death with a large majority. A lot of people also wish to be buried anonymously. So for most funerals there is not a strong connection between the ceremony and the cemetery as the burial happens at a later time.

BORN/DECEASED PER YEAR 1960-2012  
PROGNOSIS 2012-2060

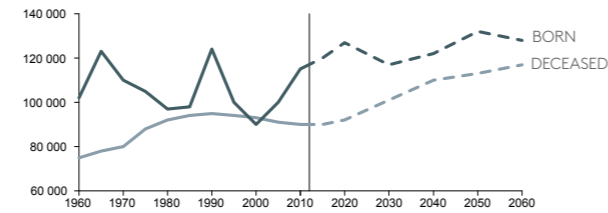

The amount of people dying each year is expected to increase

FOREIGN BORN SWEDISH PEOPLE

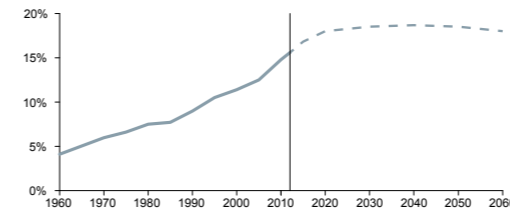

The percentage of foreign born Swedish people in 2011 was 15% and is expected to rise to app. 18% within the next few years. In Göteborg the number is 23,1% today.

CHOSEN FUNERAL TECHNIQUES 2012

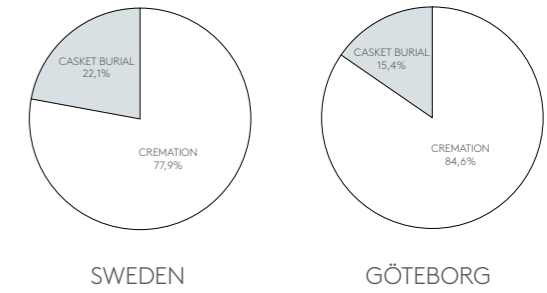

FUNERALS IN ACCORDANCE TO THE TRADITIONS OF THE SWEDISH CHURCH

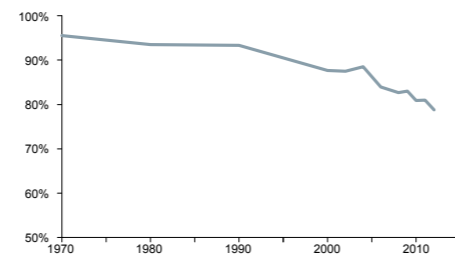

The percentage of people having their funerals in accordance with the traditions of the Swedish church was 78,8% in 2012.

PERCENTAGE OF PEOPLE BEING MEMBERS OF THE SWEDISH CHURCH

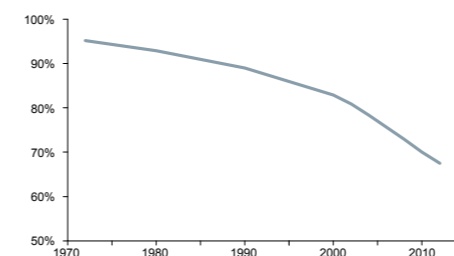

The percentage of people being members in the Swedish church was 67,5% in 2012

BURIED ASHES OF PEOPLE CREMATED 2012

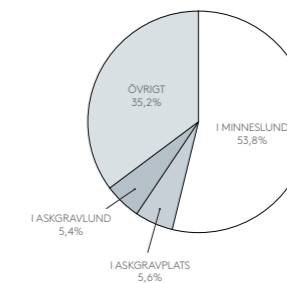

CIVIL FUNERALS

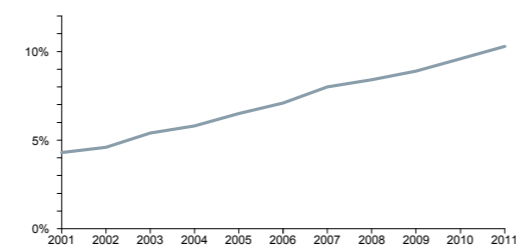

The percentage of people having a civil funeral was 10,3% in 2011.

AMOUNT OF PEOPLE ATTENDING THE FUNERAL (1997)

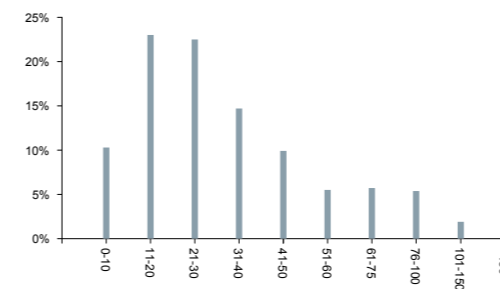

The median value of people attending is 30  
The mean value is 38  
If the funeral has been advertised the mean value is 45  
If it has not, the mean value is 17

# BACKGROUND

## THE JOURNEY OF THE DECEASED

After we die we all go through a similar process. Usually we only see our loved ones during the funeral ceremony but a lot goes on before and after.

After we die our bodies are transported to the morgue. If there are any questions about the cause of death the body goes through an autopsy. Before the deceased is transported to the mortuary the body is washed and clothed and put in a casket.

Before the funeral the casket is usually decorated with flowers or other decorations depending on cultural and religious traditions.

After the funeral ceremony the body is either buried with the casket or cremated at a crematorium. Sometimes the body is cremated before the funeral and the urn is present at the ceremony instead. After the cremation the urn is stored in the urn storage awaiting collection before either being buried or spread. Storage of the urn at home is not allowed and spreading of the ashes outside of the burial grounds demands a specific permit.

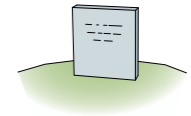
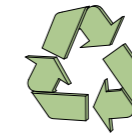
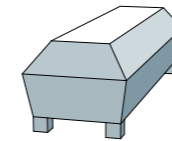
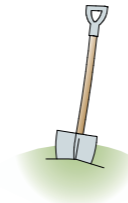
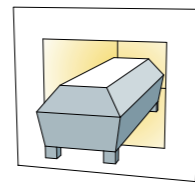
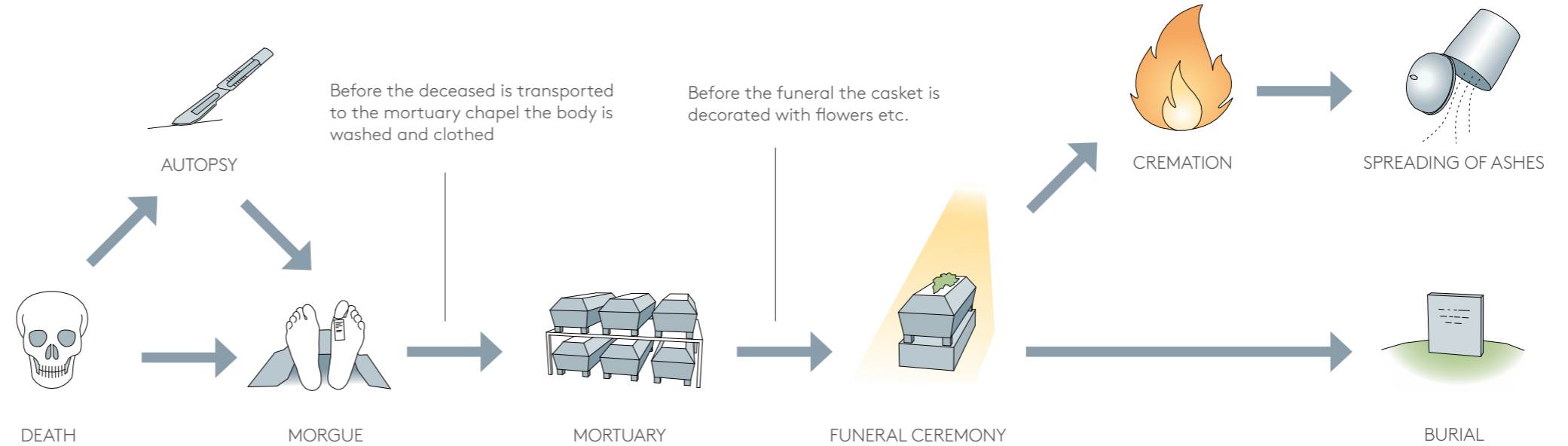

## ENVIRONMENTAL IMPACT

Many aspects of the funeral affects its environmental impact. There has been a lot of focus on the different funeral techniques, but that is only one small part of the environmental impact of the funeral.

Transportation and the many decisions in connection to the funeral has a larger impact. By having a central placement close to public transport the building will be easier to access and the environmental impact of transportation can be decreased.

By having a dining space for the memorial service close to the ceremony additional transportation can be decreased as well.

Other factors affecting the environmental impact of the funeral is up to the deceased and their family and can not specifically be influenced by the architecture.

**FUNERAL TECHNIQUE**  
Which technique that is used to dissolve the body affects the environment. Different techniques use different amounts of energy and toxins. This does however account for only a small part of the total impact.

**BURIAL OF REMAINS**  
A grave in a cemetery needs maintenance and thus have a larger environmental impact than if the remains are scattered in nature. If the remains are scattered over water it has a larger impact because of eutrophication than if it is scattered over land.

**CASKET**  
The material used to make the casket affects the environmental impact. What kind of wood, where it is from etc.

**RECYCLING**  
The possibility to recycle and reuse metals and other materials from the entire process affects the environmental impact. If everything is buried with the body the impact is larger.

**MONUMENT**  
If there is a monument, what material it is made of and where it is from affects the environmental impact. A stone monument has a larger impact than a monument made of wood.

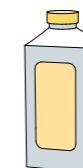
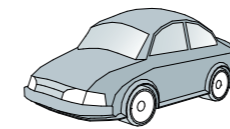
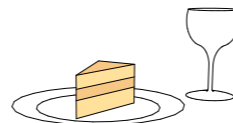

**FLOWERS**  
Where the flowers are from and how they have been grown affects the environmental impact.

**FOOD**  
What food, where it is from and how it has been grown affects the environmental impact.

**TRANSPORTATION**  
How the deceased and the mourners are transported to the funeral facilities has a large effect on the funerals total environmental impact.

**EMBALMING**  
If embalming is used to preserve the body and which embalming fluid is used affects the toxicity of the body.

# PREPARATORY STUDIES

## STUDY VISITS

A part of understanding the functions and architectural qualities of spaces connected to funerals consisted of making several study visits. I have visited classical funeral chapels and churches as well as newer sacral buildings with a pronounced non-denominational orientation.

I have chosen to study the following buildings:

- Skogskapellet (Skogskyrkogården)
- Uppståndelsekapellet (Skogskyrkogården)
- Skogskrematoriet (Skogskyrkogården)
- Österhaningesalen
- Storkällans kapell och krematorium
- Årsta kyrka
- Markuskyrkan i Björkhagen
- Källeredes ceremonibyggnad
- S:t Olof och S:t Sigfrids kapell
- Kvibergs krematorium

I have evaluated the buildings based on a few chosen criterias to get a better understanding of their different qualities:

Size, intimacy, atmosphere, architectural clarity, architectural detailing, flexibility in direction, flexibility to furnish, connection to the outside.

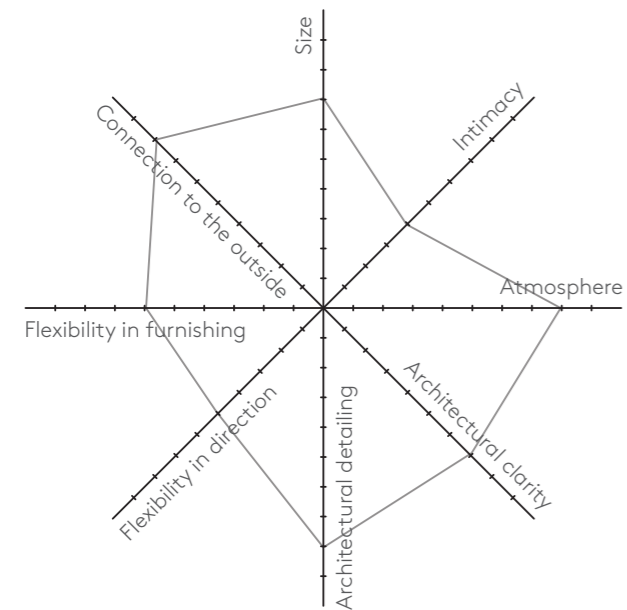

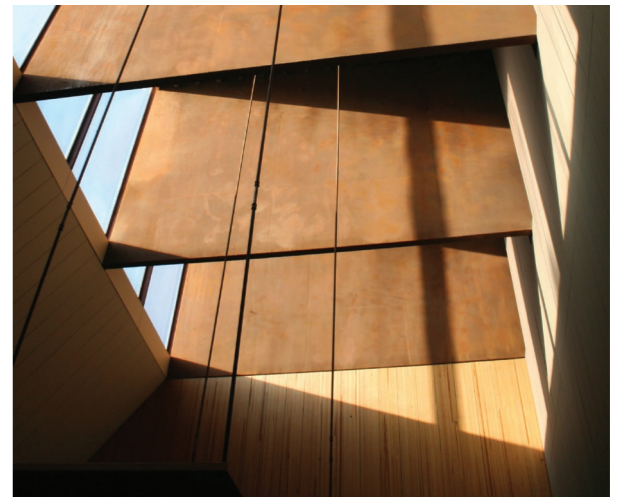

## PREPARATORY STUDIES

### VOLUME, LIGHT AND MATERIAL

An important part of sacral architecture and buildings used for ceremonies and funerals are the way the buildings use space, light and materiality to get the visitor in a specific mood.

The next part of my preparatory studies was investigating how volume as well as light and different materials can be used to create the atmosphere I was looking for.

In my thesis I wanted to experiment with a new way of making sacral architecture that differs from the classical way of designing rooms and using light while still having a similar reverent feeling and dignity. A way of doing that was working with a different kind of material. I became interested in the material qualities of thin textile and its specific properties when it came to light, shadows, transparency and tactility that I found to be well suited for sacral architecture.

I experimented with different kinds of textiles and ways of using the textile to get various light, shadow and spatial qualities, which later became the basis of my project.

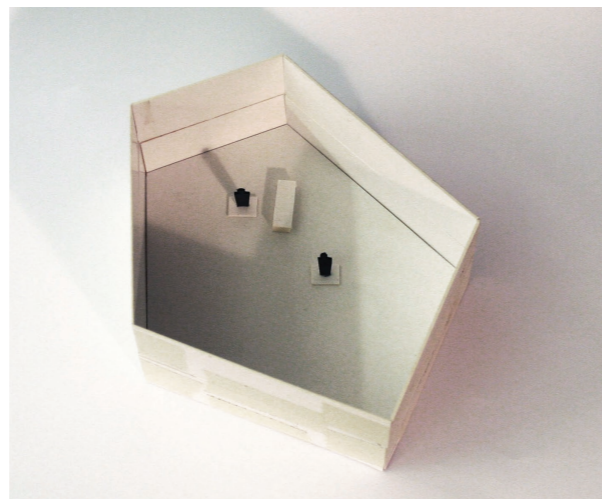
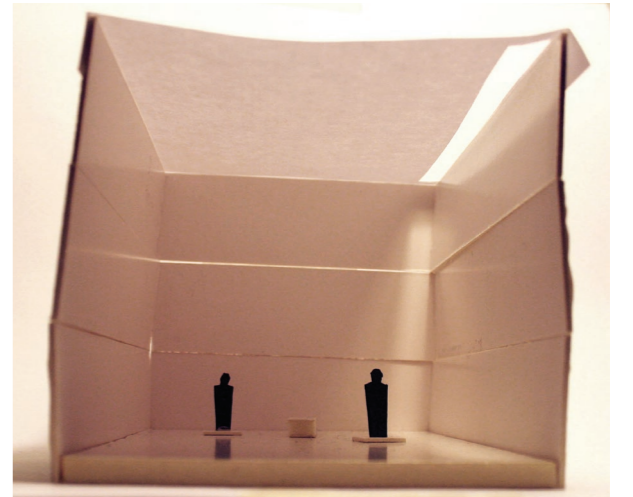
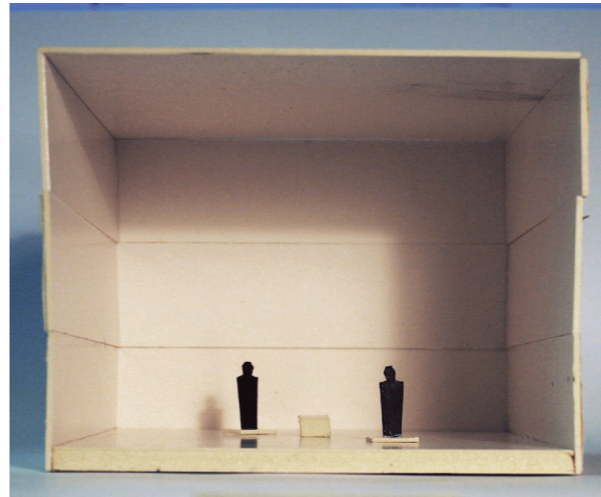
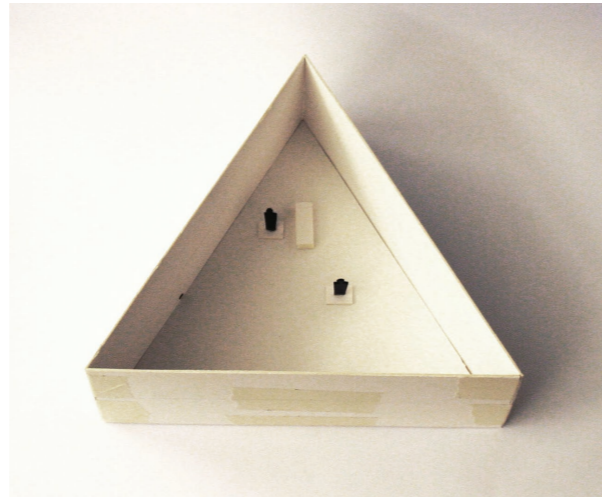
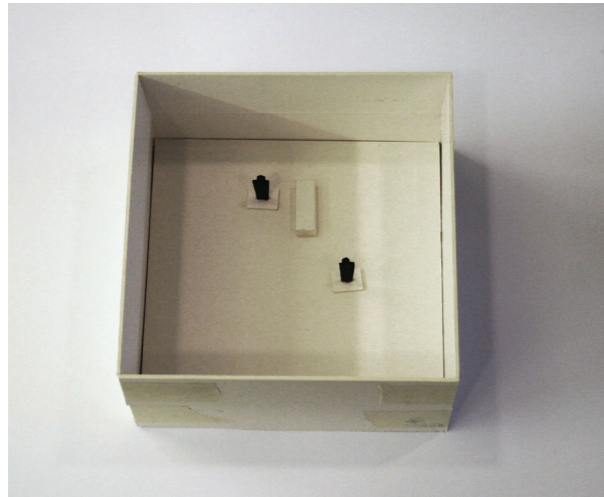

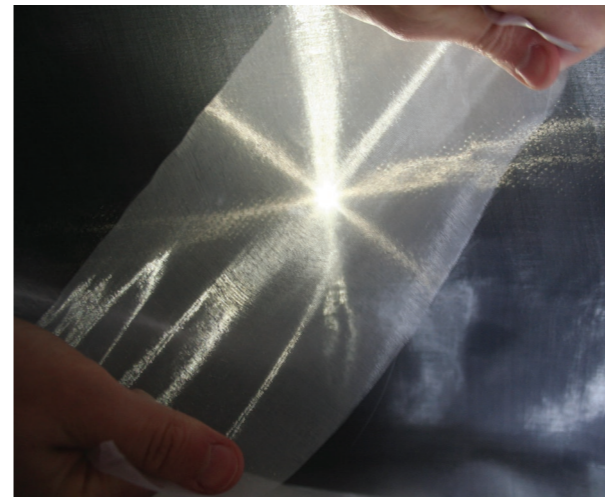
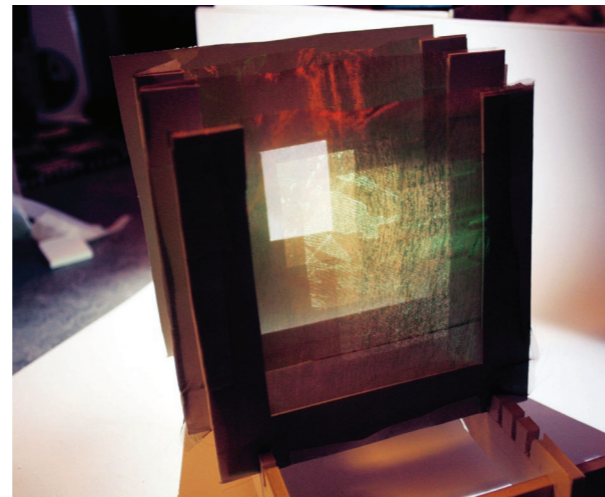
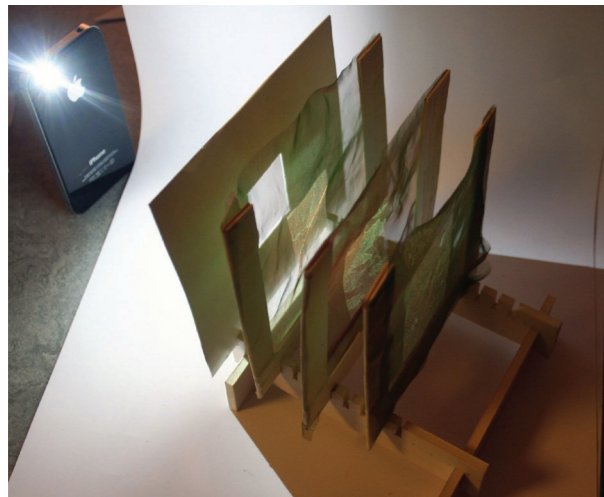
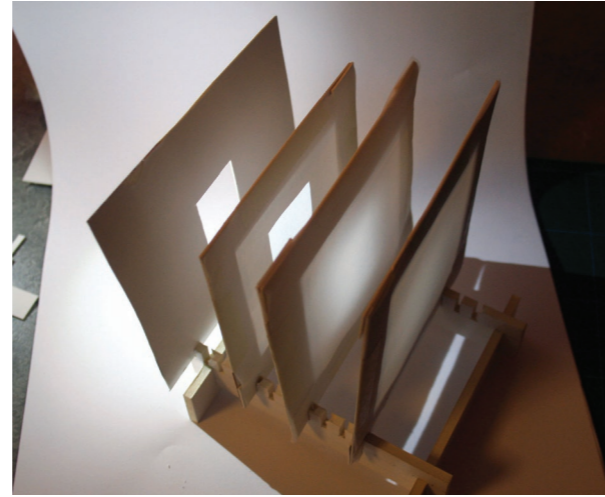
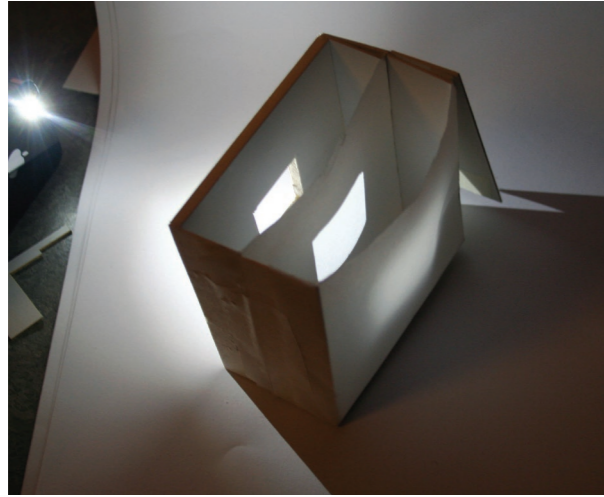

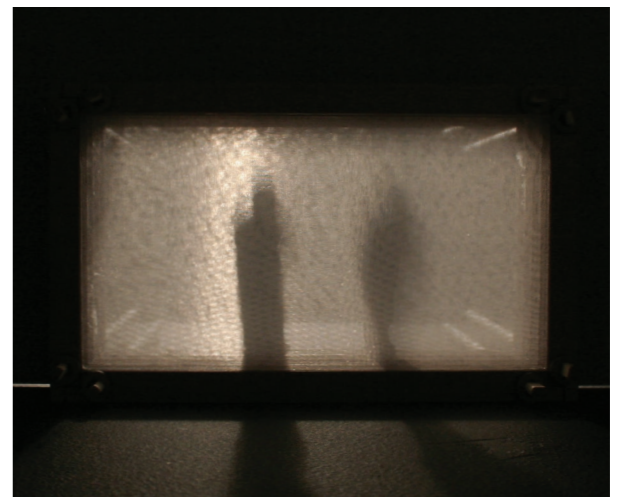
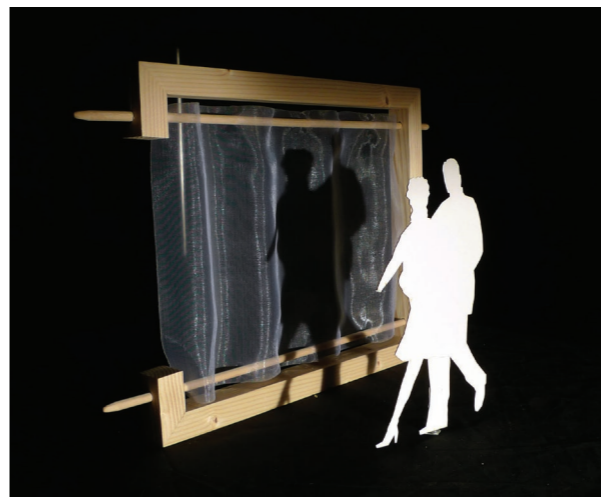
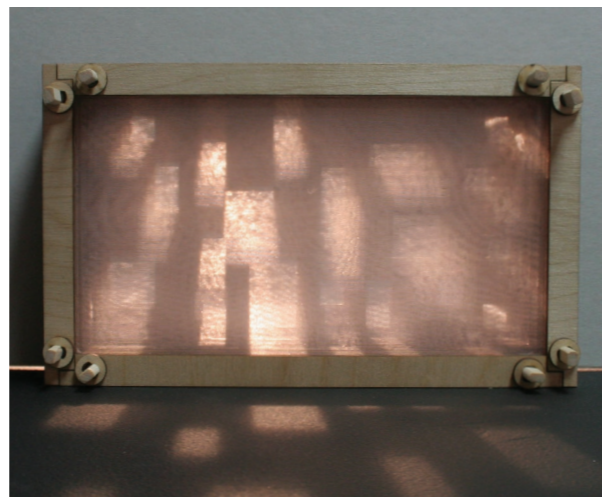
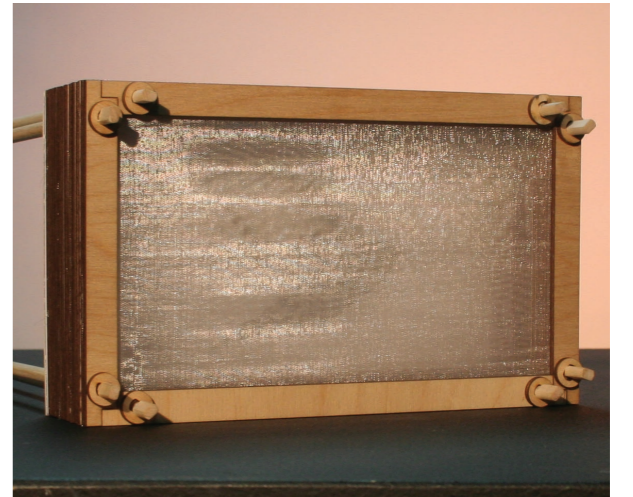
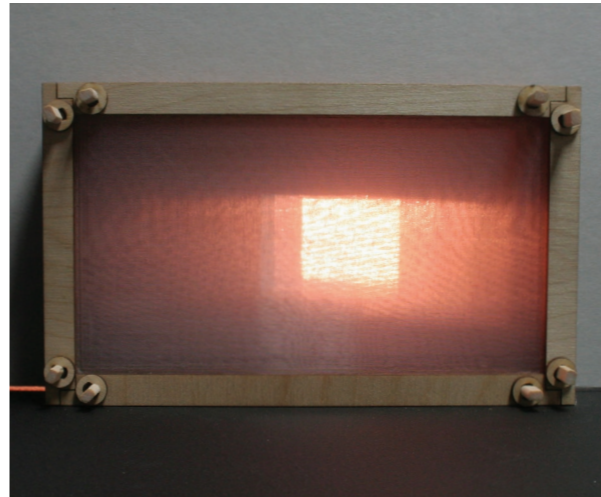



## CONCLUSION OF STUDIES

### CRITERIA FOR THE SITE

- A central placement in the city makes it easy to access for all people.
- A close proximity to public transport makes it easier to travel in a more environmentally friendly way.
- A calm placement, close to greenery with some privacy helps set the mood for the funeral and calms the visitors.
- A close proximity to a cemetery keeps the possibility of burial in connection to the funeral service.

### CRITERIA FOR THE BUILDING

- A flexible building that can suit the individual needs of many different people.
- A building that can be used for larger funerals
- A building that can be used for other purposes, making the building more public and efficient in its use.
- A universal sacral feeling and dignity to the building without being religious sets the mood for the funeral without excluding people.
- Having a similar dignity as other sacral buildings but differ enough in the design to signal that it is something else.
- A dignified design of the entire process, the rooms for the ceremony as well as the rooms for taking care of the deceased.
- Using the unique properties of textile to enhance the experience of the architectural space and surroundings.

# THE SITE



## PLACEMENT IN GOTHENBURG

The building is situated close to Redbergsplatsen. The site is close to the city centre and has very good connections to public transport, making it easy to access. The site is close to the Östra Cemetery keeping the possibility of casket burial in connection to the cemetery.



## THE SURROUNDING AREA

The surrounding area consists of mainly residential buildings with 1-3 floors. The site is situated on a green hill on the opposite side of the road to Östra cemetery. It is close to public transport and the cemetery while still being relatively private and calm. The area has quite a few christian buildings, the small chapel on Östra cemetery being one of them. My proposed building will function as a complement to the existing chapel as well as being an alternative to the religious buildings.

- |  |                |                              |
|--|----------------|------------------------------|
|  | Östra cemetery | Educational                  |
|  | Green areas    | 1. Bagaregårdsskolan         |
|  | Sport          | 2. Ånässkolan                |
|  |                | 3. Redbergsskolan            |
|  |                | Cultural                     |
|  |                | 4. Studieförbundet           |
|  |                | 5. Kulturhuset Kåken         |
|  |                | Religious                    |
|  |                | 6. Östra kapellet            |
|  |                | 7. Gilead                    |
|  |                | 8. St. Pauli church          |
|  |                | 9. Finska Pingstförsamlingen |
|  |                | 10. Redbergskyrkan           |
|  |                | 11. Härlanda church          |



## THE SITE TODAY

The site consists of a small hill, which is mostly covered by trees with a smaller open area on the top. It is used mainly for recreational purposes. The site has a close connection to Landeriet and Bagaregårdsskolan. Landeriet used to contain a culture centre with a library, but since those activities have moved to Kulturhuset Kåken, the building is mainly used for offices. Nordengården is also close by and is used as a conference centre. The lower parts of the hill can be reached by car, while the upper parts are only reached by foot.

- |  |               |                      |
|--|---------------|----------------------|
|  | Bus/Tram stop | 1. Bagaregårdsskolan |
|  | Roads         | 2. Landeriet         |
|  | Tramway       | 3. Nordengården      |
|  | Bycicle       |                      |
|  | Walking       |                      |



## PROPOSED CHANGES

The ceremonial building is placed on the hill, right next to the open area, keeping it for recreational use. Additional drivable pathways are added to make the building accessible for all visitors and deliveries. The driveable paths are for low speed driving, slightly wider and are used by both cars and pedestrians. The existing connections are kept and the pathways for the entire area are covered in a uniform stone paving. Additional seating and rest stops are added to the area.

- |  |               |                        |
|--|---------------|------------------------|
|  | Bus/Tram stop | 1. Bagaregårdsskolan   |
|  | Roads         | 2. Landeriet           |
|  | Tramway       | 3. Nordengården        |
|  | Bycicle       | 4. Ceremonial building |
|  | Walking       |                        |

# THE SITE



1



2



3



4



5



6

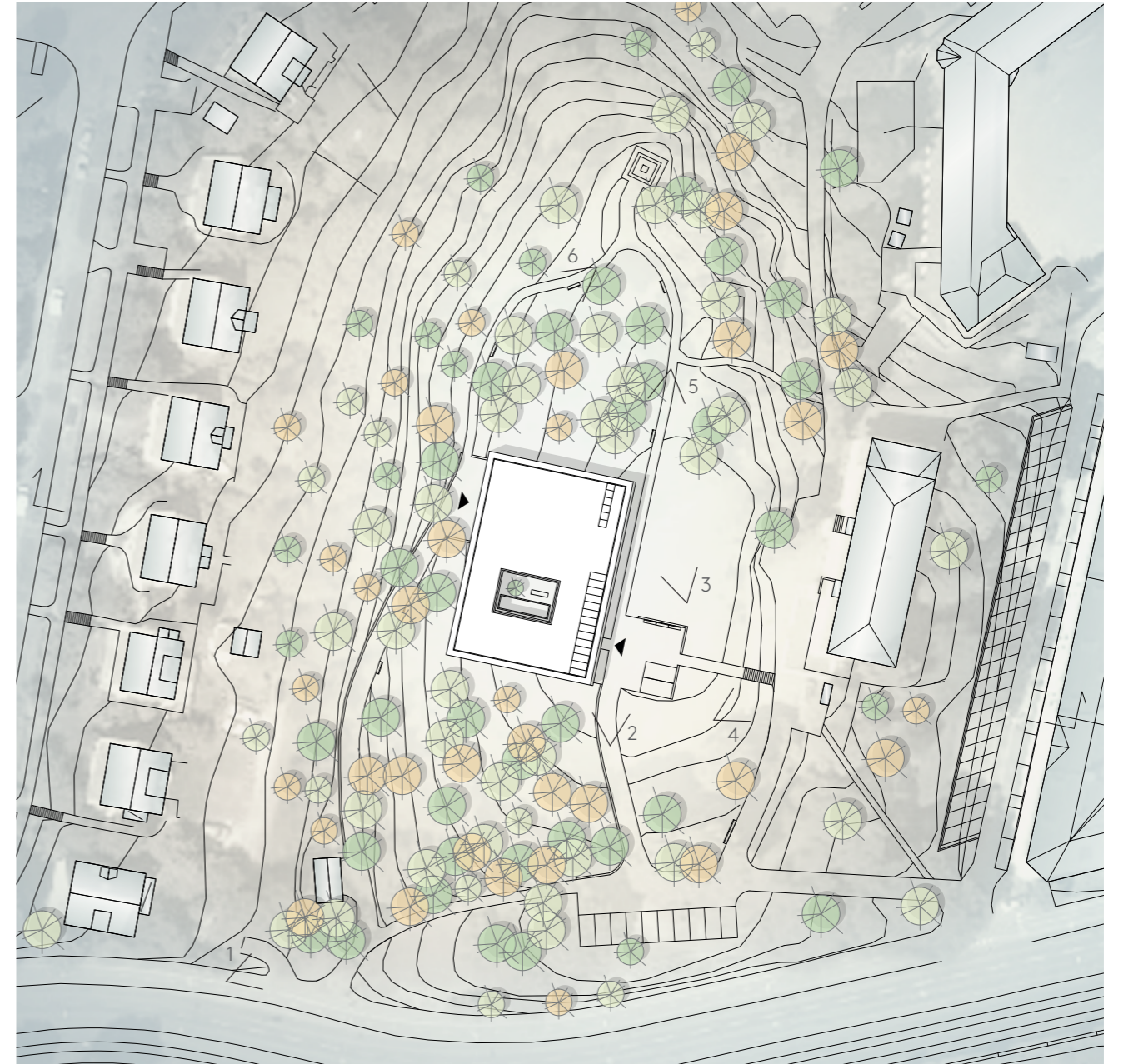

Site plan 1:1000

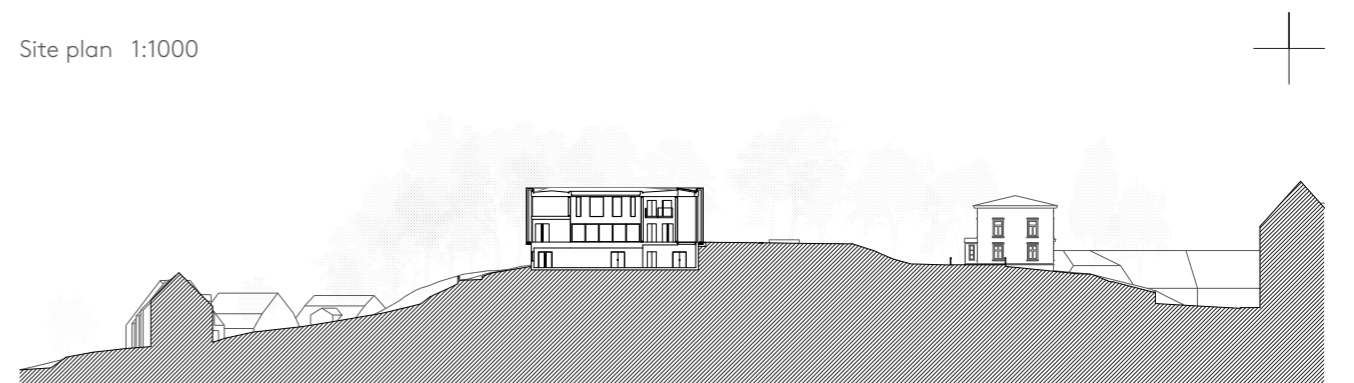

Section 1:1000

# ARCHITECTURAL CONCEPT

## BUILDING VOLUME

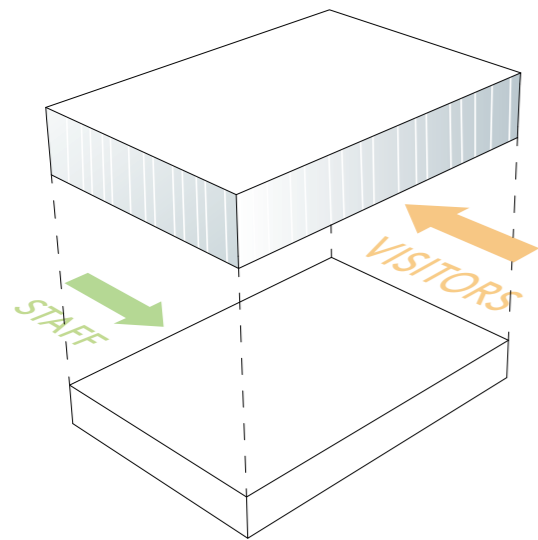

The building is divided into two levels with separate entrances. The upper level is for the visitors and the lower level is for the staff and handling the caskets.

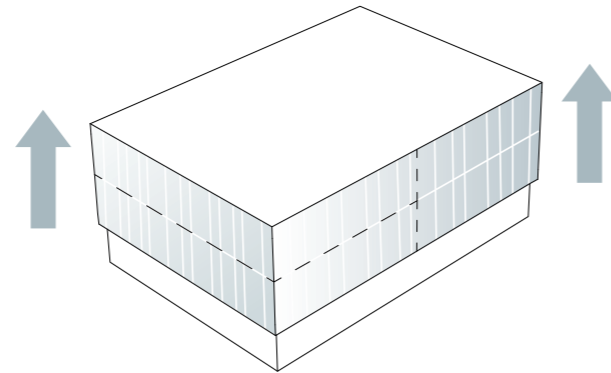

The height of the upper volume is increased to leave room for two floors in certain areas and create double height rooms in other areas.

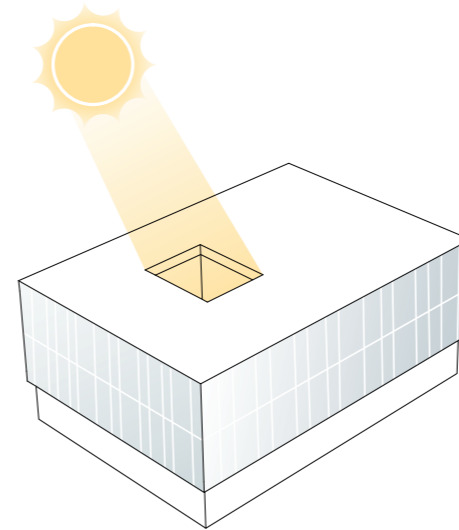

A hole is made in the volume, creating a green courtyard and bringing down sunlight into the center of the building.

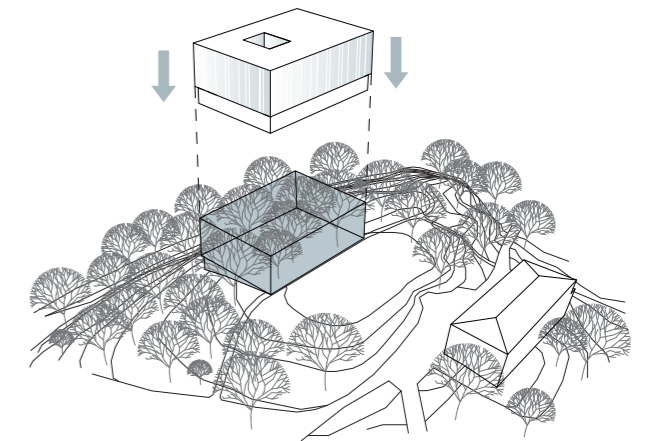

The building is placed on top of the hill, right next to the open space. Leaving the space to be used by everyone.

## INTERIOR CONCEPT

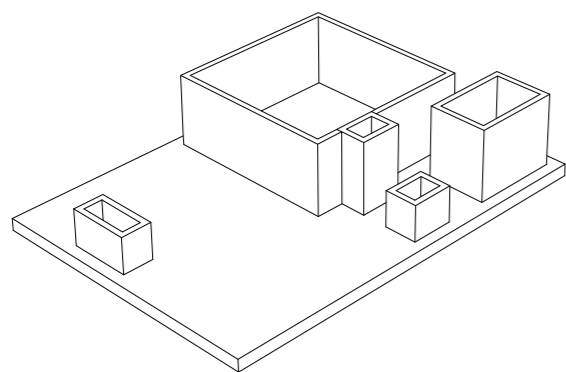

The functions in need of more privacy and darkness are placed within concrete boxes.

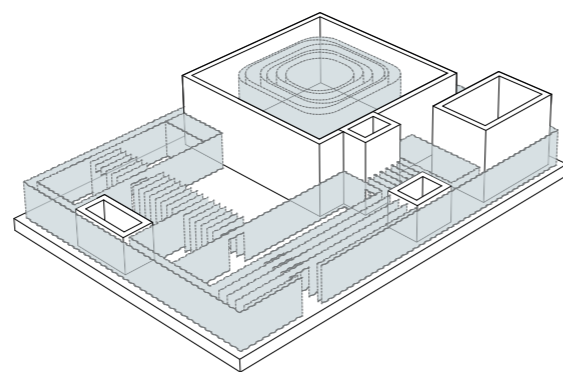

The rest of the building is wrapped in layers of textile, creating rooms in between the boxes.

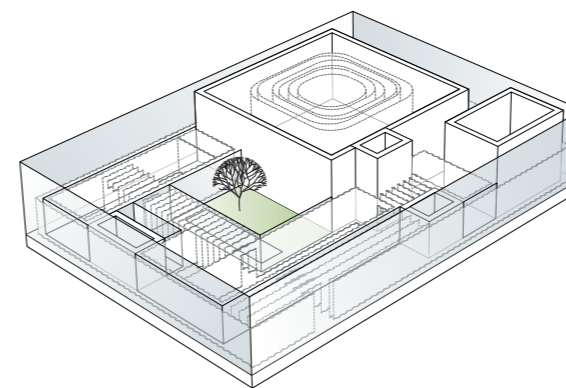

Glass is added where it is needed, mainly to create a good climate in the building and for sound insulation.

# THE UNIQUE PROPERTIES OF TEXTILE

Textile has a lot of material properties that makes it interesting to use in an architecture project - its varied transparency, its reflecting and illuminating properties, how shadows and light are projected onto its surface, its movement and its softness. The textile is affected and transformed by its surroundings, making it a very living material.

Textile has a long tradition associated with death and funerals. For example in the shroud of the deceased, the veil of the mourners or as decoration of the casket or the funeral chapel. I want to explore how you can use textile as an architectural element that is a part of the building instead of something added later to decorate the already finished building.

I want to use textile to give a softness and warmth to the funeral and use the textiles material properties to give life and variation to the building.

The textile becomes the canvas on which the natural phenomenas are projected. The sunlight is filtered through the textile, making it glow, the trees outside creating shadow sillhouettes on its surface and the wind and the motion of the visitors causing the textile to gently dance. The textile is used to make the visitor more aware of life around them and give them comfort in their vulnerable situation.

## 1. TRANSPARENCY

Depending on the viewing angle, the textile can be almost completely transparent or completely opaque. Standing perpendicular to the textile makes it the most transparent. Viewing it from a sharper angle makes it more opaque. The more layers of textile the less transparent the textile becomes.

## 2. REFLECTIONS

The textile catches light and reflects it. The imperfections and creases in the textile creates a melange shine that changes when the textile moves. Depending on how the textile is lit it changes properties and can become more or less transparent. The thicker the layers of textile, the more light is reflected.

## 3. ILLUMINATION

When lit, either by artificial or natural light the textile is illuminated, diffusing the light and spreading a soft glow. The more layers of textile is used the softer the glow, until it becomes too dense to let the light through.

## 4. SHADOW PROJECTION

Because of the textile's transparent, illuminating and reflecting properties shadows and light are projected onto the layers of textile, creating a seemingly three dimensional shape from the object blocking the light.

## 5. LIGHTNESS

The light weight and softness of the textile makes it easy to affect and the slight breeze from the wind or people passing by makes the textile move. Because of its light weight very thin constructions can be used to hold the textile.

## 6. TACTILITY

The thinness and softness of the textile together with its movement makes it inviting to touch, affecting its surface, similar to the feeling of touching water. This can create a sensory experience not common to conventional architecture.



1

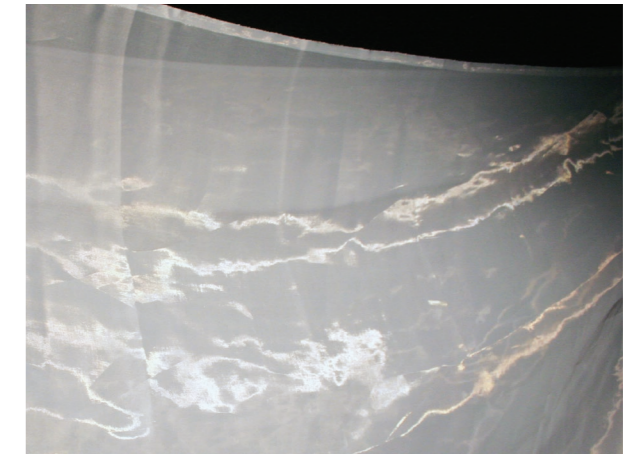

2



3



4



5



6

# USING TEXTILE IN THE BUILDING

## CUTTING THE TEXTILE TO CREATE ROOMS

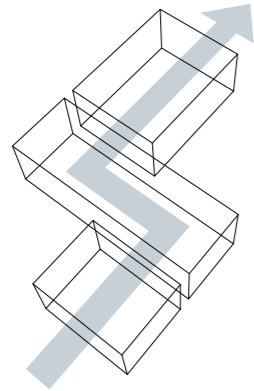

The building is divided into a sequence of rooms that the visitors pass through when attending the funeral.

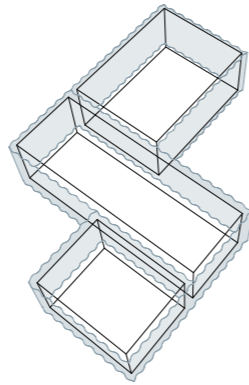

The rooms the visitors are in contact with are wrapped in textile.

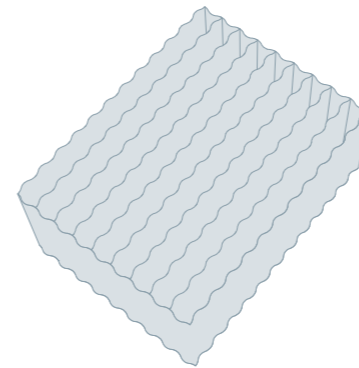

The rooms are filled with additional layers of textile.

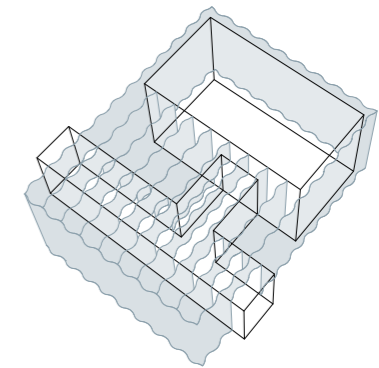

Volumes are cut out of the textile, dividing the rooms into smaller parts.

## ALTERING THE TEXTILE FOR DIFFERENT SPACES

By varying the curves and density of the textile the walls in the building become more or less transparent, reflecting and transporting light in different ways giving each room specific qualities.

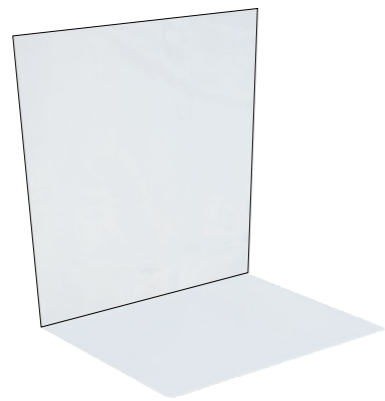

### STRETCHED TEXTILE

When stretched the textile is almost completely see-through from most angles. The wall transmits a lot of light. The wall has some illumination and reflections.

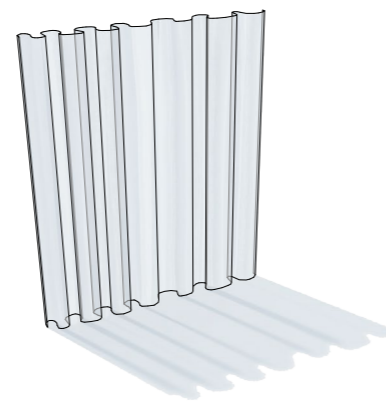

### LOOSE CURVATURE

With a loose curvature the textile is still see-through. The wall transmits a lot of light and has more illumination and reflections than the stretched fabric.

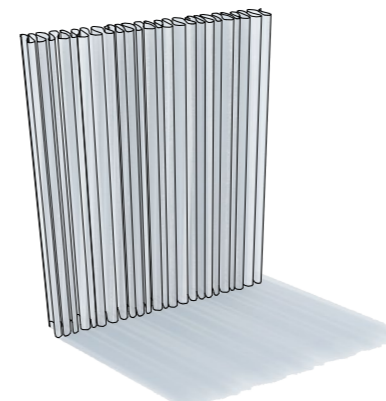

### DENSE CURVATURE

A dense wall with a lot of textile and curvature makes the textile less see-through. The wall still transmits light, although less than before. The wall has a lot of illumination and reflections.



### COMBINATION

In the building the curvature and density of the textile varies depending on its location, making the walls almost completely transparent in some areas whereas in other areas you can only see blurred light and shadows.

# USING TEXTILE IN THE BUILDING

## WALLS FOR DIFFERENT FUNCTIONS

The textile is used in different ways throughout the building, depending on the specific needs of the rooms. Some rooms have a higher need for privacy while others have higher functional needs.

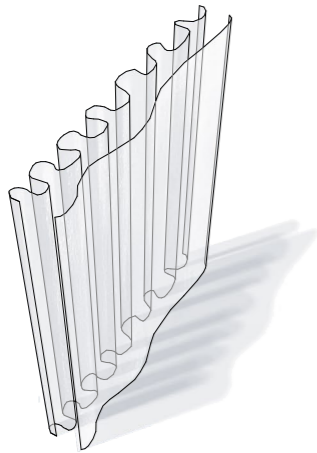

### LAYERS OF TEXTILE

A wall consisting of layers of textile with different curvatures.

- Only used in the interior.
- Transports light
- Reflects light
- Illuminates
- See-through

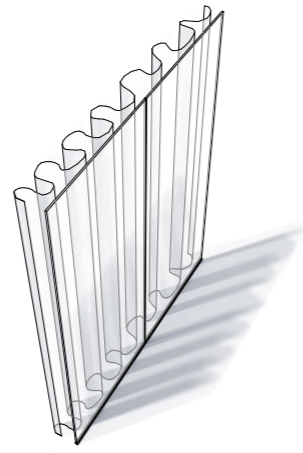

### TEXTILE + GLASS

A wall consisting of layers of textile with glass towards one side.

- Used for sound insulation
- Used for wet areas
- Transports light
- Reflects light
- Illuminates
- See-through

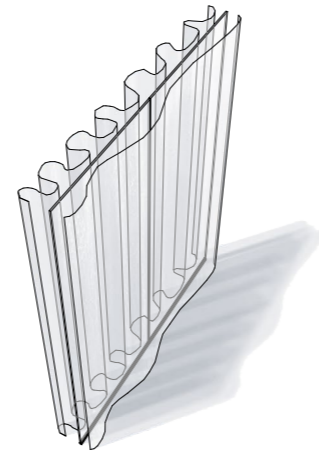

### TEXTILE + GLASS + TEXTILE

A wall consisting of layers of textile with glass in between.

- Used for sound insulation
- Transports light
- Reflects light
- Illuminates
- See-through

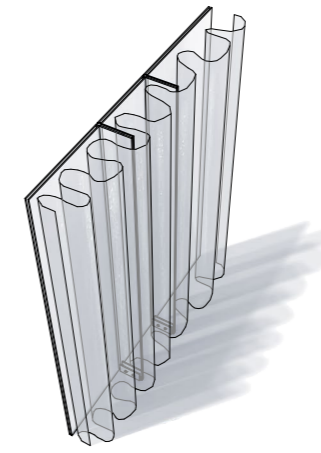

### INSULATING GLASS + TEXTILE

A wall consisting of layers of textile with an outer layer of insulating glass.

- Used for heat insulation towards unclimatised or semi-climatised areas.
- Sound insulation
- Transports light
- Reflects light
- Illuminates
- See-through

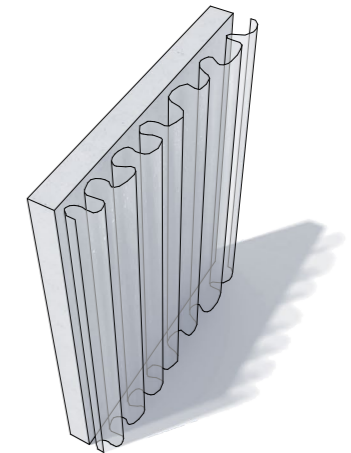

### CONCRETE + TEXTILE

A wall consisting of concrete covered with layers of textile.

- Less sensitive to wear and tear
- A dense wall - fitting for areas in need of more privacy.
- Sound insulation
- Reflects light
- Illuminates

## MATERIAL PALETTE

The building consists of a few carefully selected materials where the textile is the main feature. The other materials are chosen because of their physical as well as tactile properties, to either work with or in contrast to the lightness of the textile as a way to elevate the experience of the architecture.



### TEXTILE

A thin textile is used as the main feature of the building in all rooms the mourner and the deceased come in contact with.

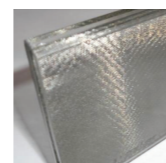

### LAMINATED GLASS

In the facade the textile is laminated inbetween the glass. Giving it a shimmer from the textile and diffusing the light.

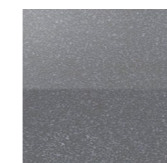

### DARK TERRAZZO

Dark terrazzo floor reflects the textile walls and contrasts to the lightness of the textile.



### IRON FREE GLASS

Glass is used for climat protection, sound insulation and in wet areas.



### LIGHT ASH WOOD

Light ash wood is used in the furniture and door handles to give a warmer feel to the surfaces people touch.

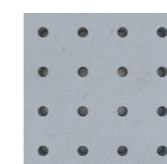

### PERFORATED CONCRETE

The concrete is perforated in some areas for acoustic reasons.

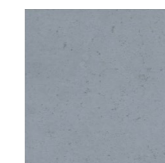

### BARE CONCRETE

Bare concrete is used in the walls, to block out light and contrasting the thin textile. Its melange surface and natural variations is similar to the textile surface.

# LIGHTING

An unconventional material needs unconventional lighting. The textile's illuminating and reflecting properties makes it possible to reflect a diffused light into the room, further enhancing the texture and movement of the textile.

Depending on if the textile is frontlit or lit from behind it generates a different light and affects the shadows and reflections differently. This can be used to set the mood in the building.

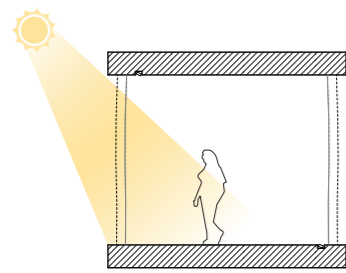

During the day the building is mainly lit by sunlight. The textile is illuminated by the sun, creating a soft light in the interior.

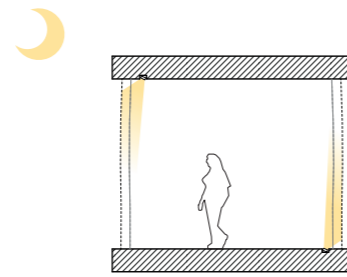

When there is not enough sunlight the textiles are lit with artificial light from recessed luminaires in the ceiling and in the floor. The textile is illuminated reflecting the light into the room.

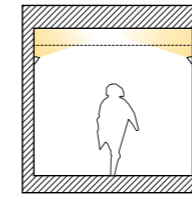

When it is not practical to have textile on the walls it is placed in the ceiling. The textile is lit by uplights in the walls, creating a glowing ceiling that reflects the light down into the room.

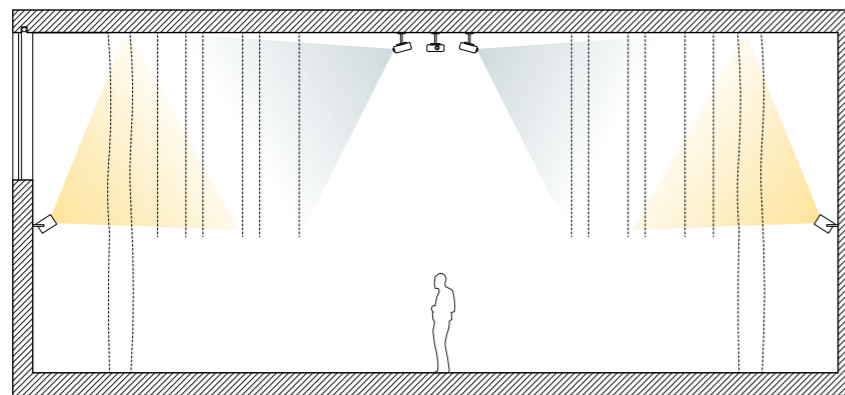

In the ceremonial room the hanging textile in the ceiling can be lit from two directions, creating a glowing, textile chandelier. Projectors in the ceiling can be used to project patterns, colors or video on the textile surface, transforming the textile into whatever the users wish. Sunlight lights up the room during the day, through high placed windows, creating light shapes on the textile, but can be blocked out with built-in blinds.

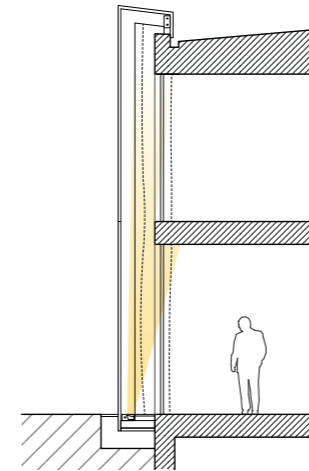

The textile in the facade is lit from the outside, making the building light up like a lantern in the dark. The mix of the light on the facade and the light from the interior makes the different layers of textile have gradients of transparency and illumination.

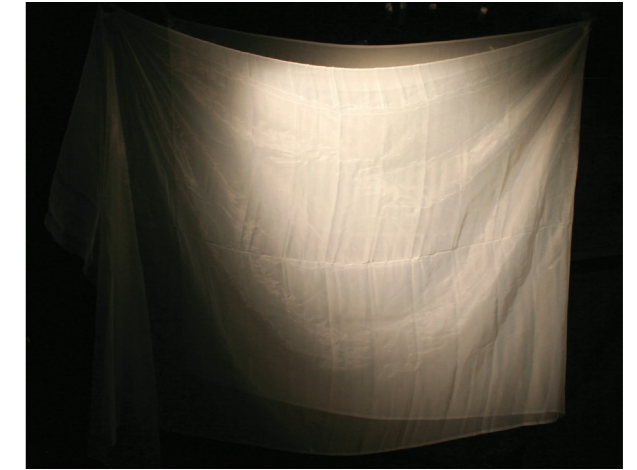

Lighting the textile from the front



Lighting the textile from the back



A mix of front and back lighting

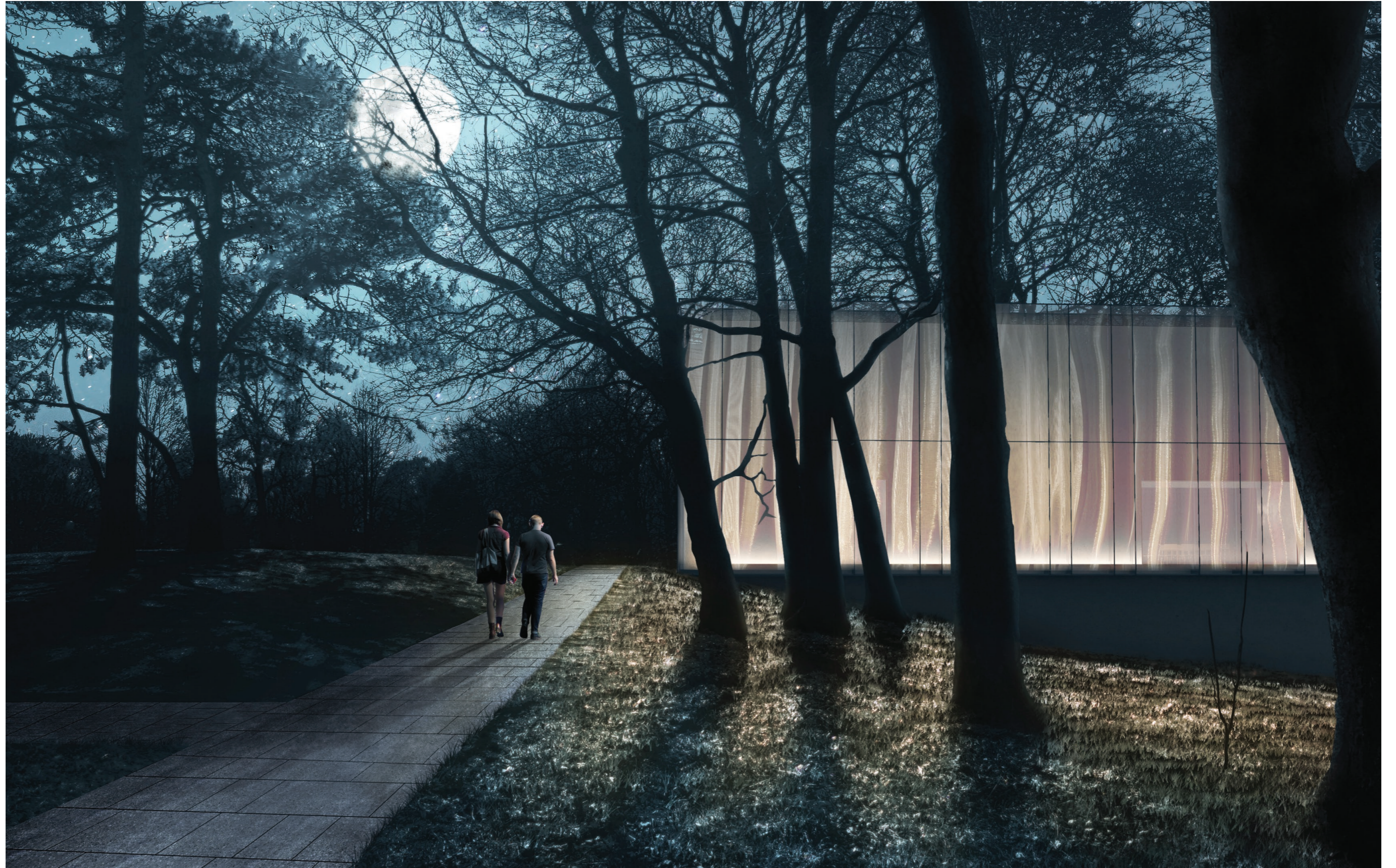

Exterior view

## DOUBLE-SKIN FACADE

To enhance the textile's translucent and illuminating qualities a glass facade is used all around the building. The sunlight filters through the layers of textile, illuminating them and leaving shadows from the trees and bypassers on the walls inside. The layers of textile also work as sunshading.

A double-skin facade is used as a thermal buffer, creating a semi-climatized space in between the layers of glass. The space is ventilated to get rid of excessive heat. This makes the facade slowly dance as the textile moves from the draft.

Water from the roof are led down to the ground through the semi-climatized space.

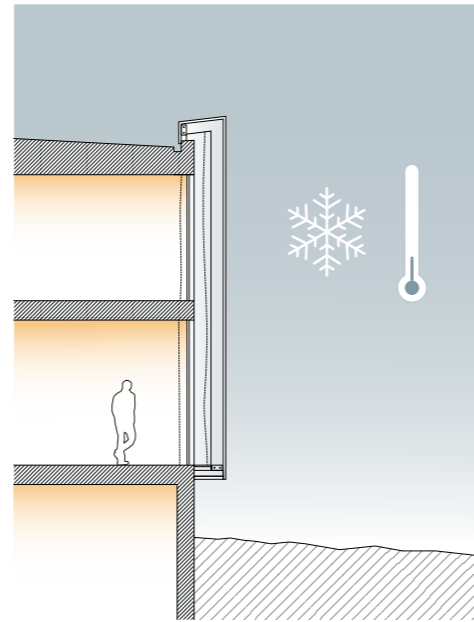
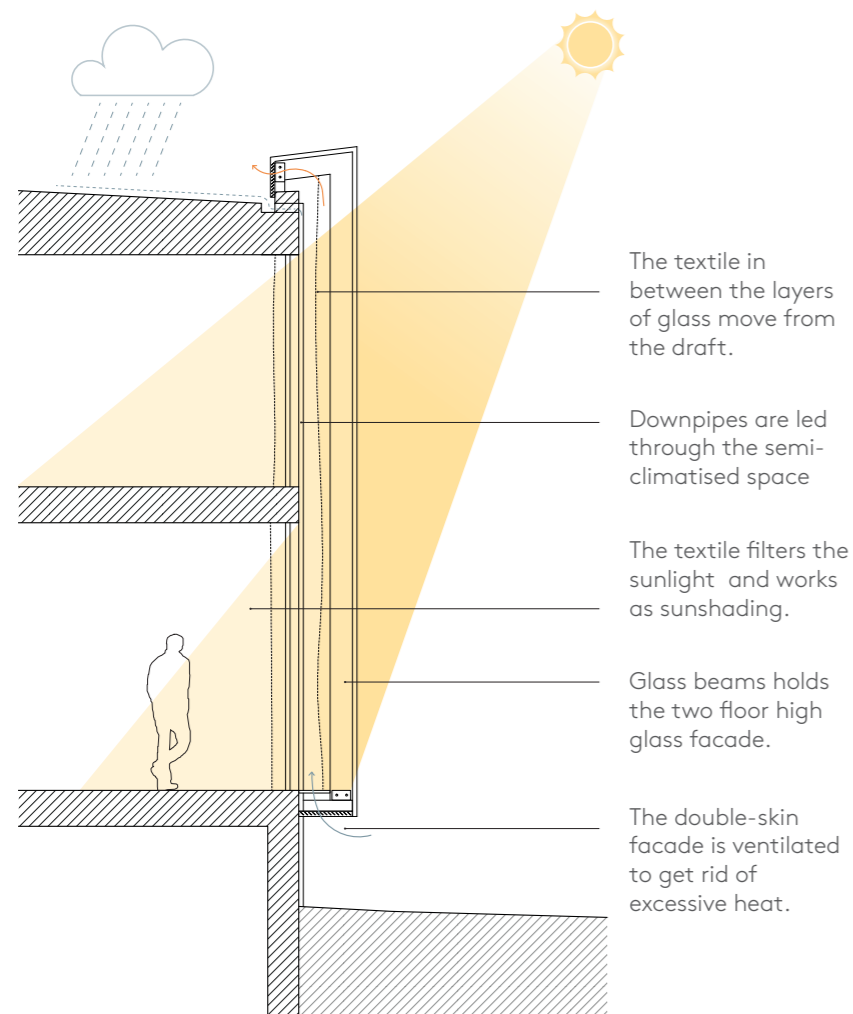

### WINTER

During the winter the double-skin facades helps preheat the air as well as minimising heat transmission loss.

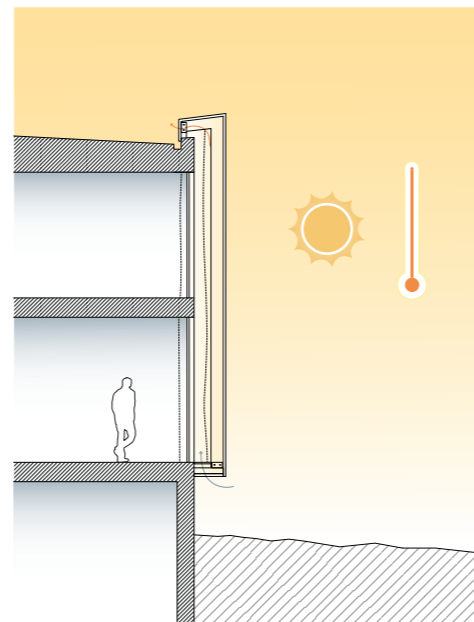

### SUMMER

In the summer the facade cools the building by ventilation of the semi-climatized space. The exposed concrete slabs and walls work as a thermal buffer keeping the inside temperature stable.

## LOAD-BEARING STRUCTURE

The load-bearing structure consists of concrete slabs and walls as well as steel pillars. The concrete walls are used to create rooms with more privacy and less direct sunlight while the steel pillars are mainly used in the public areas to create more openness and transparency.

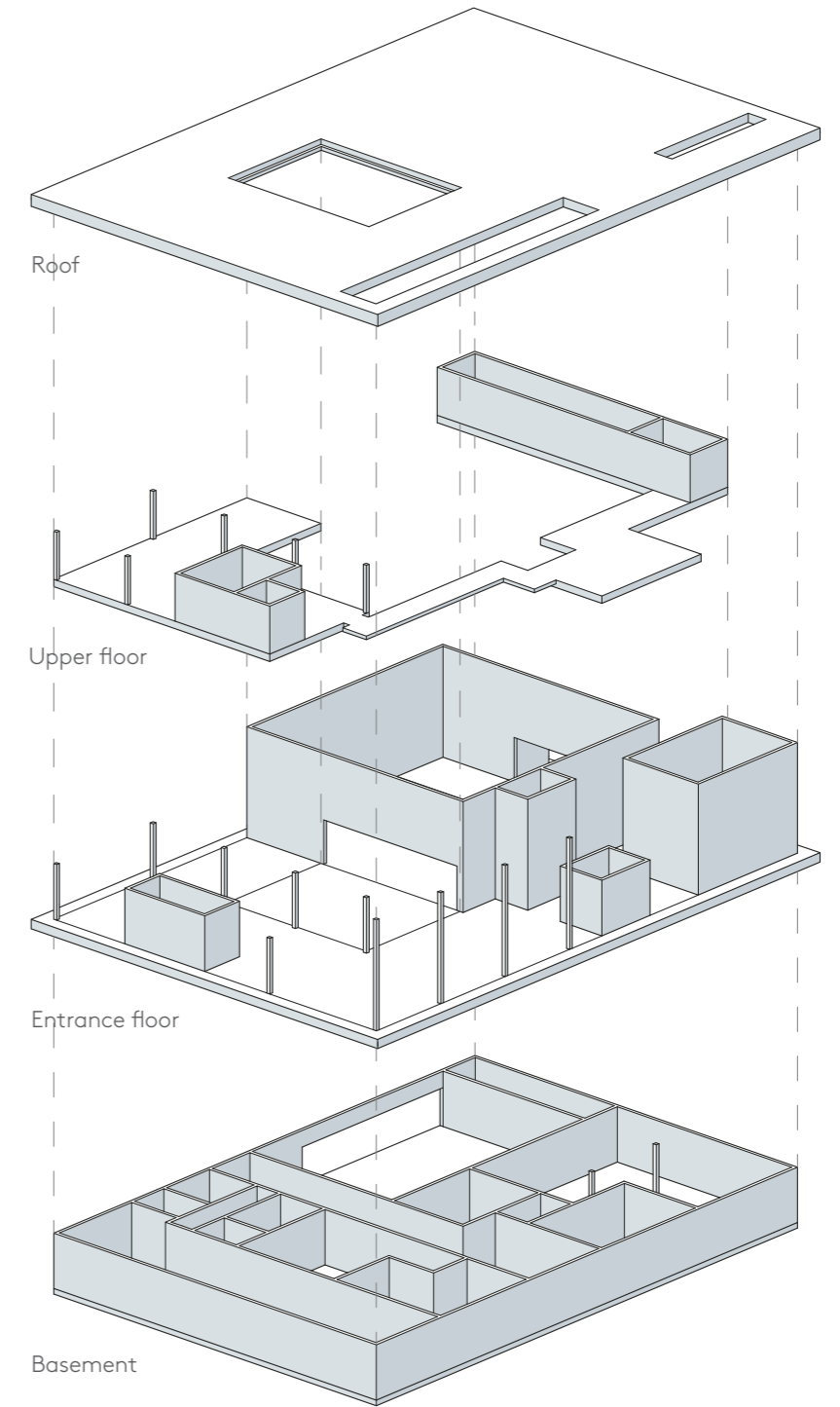

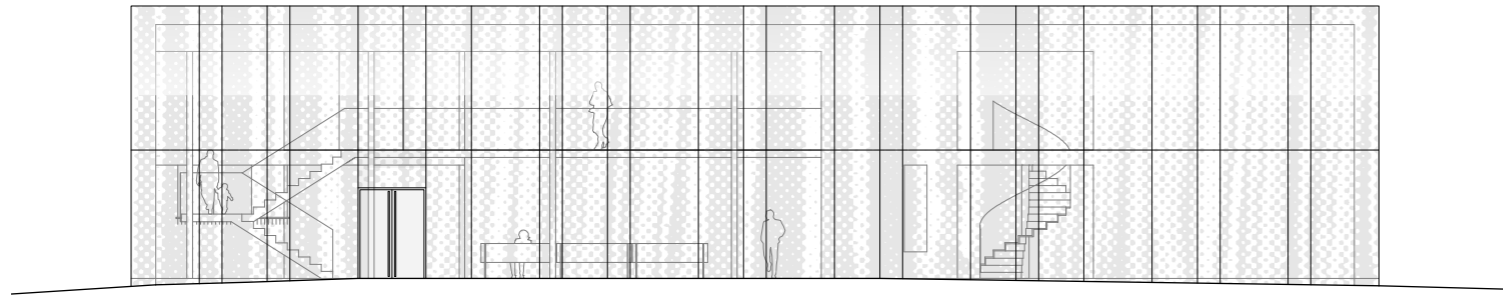

East Facade

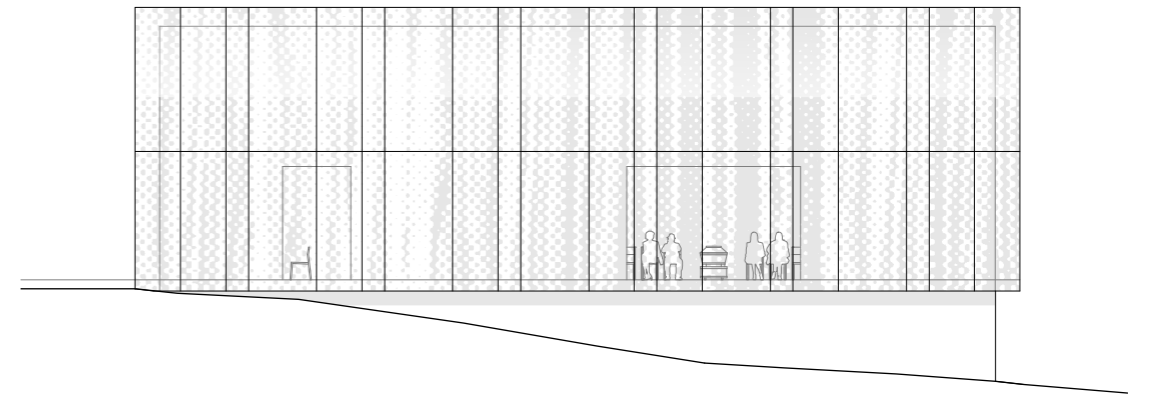

North Facade

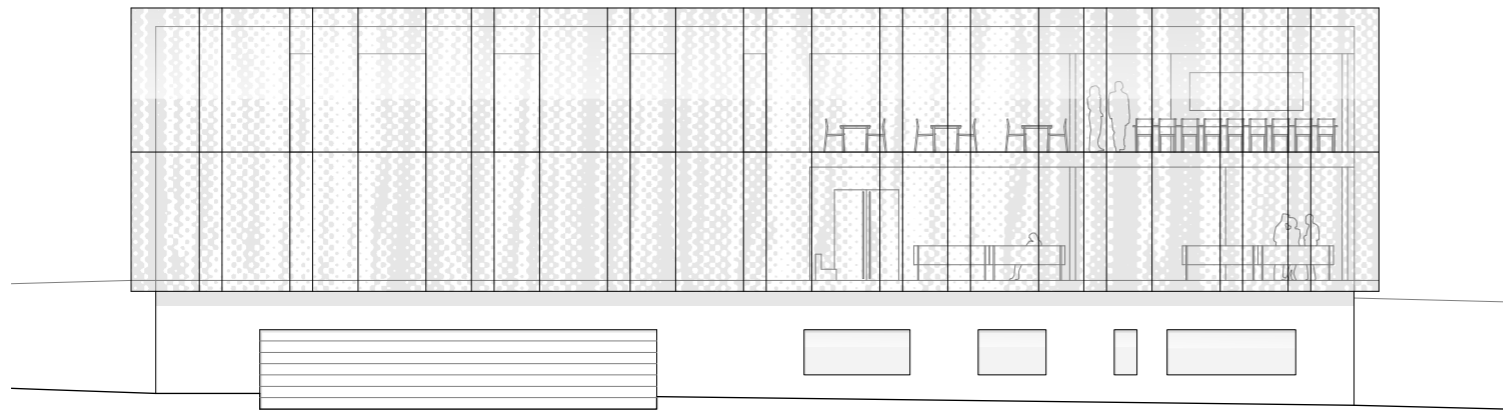

West Facade

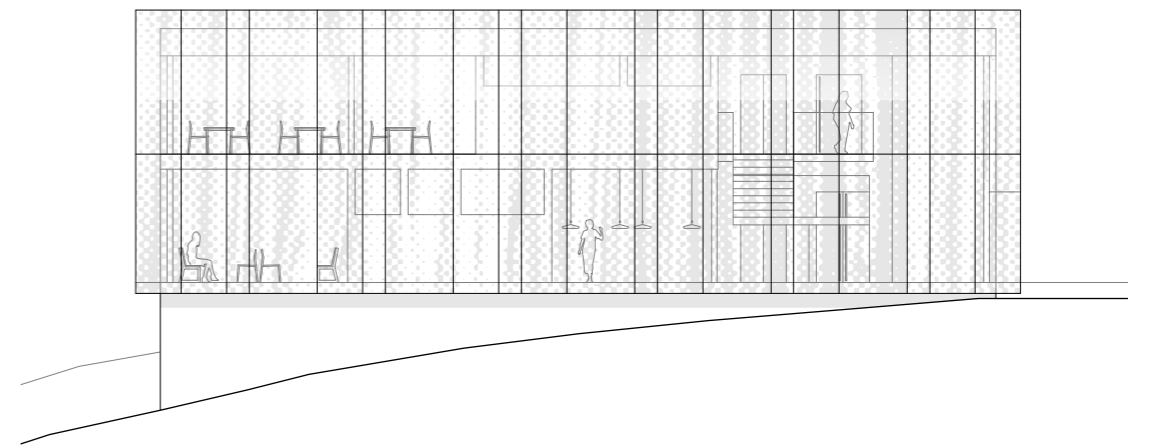

South Facade



## EXPERIENCING THE BUILDING

The building is designed with two journeys in mind. The journey of the visitors attending the funeral, and the journey of the deceased.

The visitors enter through the upper floor from the green open area. Moving in stages further and further into the core of the building - the ceremonial room. The entrance level is bright with textile walls filtering the sunlight and is meant to give a sense of hope and warmth to the visitors. The diffused transparency makes it possible to see people moving in another room without making them feel exposed.

The ceremonial room is darker to put emphasis on the casket and the funeral, and to contrast from the lightness of the rest of the building. After the funeral the visitors can exit through another door and move to the second floor of the building for the memorial service. The second floor has a view to the forest and the tree tops, giving it a lighter feeling, meant to symbolize that the hardest parts are through, leaving the funeral behind them and celebrating the life of the deceased rather than mourning their death.

The casket is brought to the building through the forest arriving at the entrance on the basement level. The interior is darker with mainly exposed concrete walls and fewer, directed sources of light in contrast to the upper levels. Textile is mainly used in the ceiling, reflecting light down into the rooms. The space is designed to be more than just a storage of the deceased but a dignified resting. Before the funeral the deceased is brought to the preparation room situated in the end of the corridor which is lit from above. The casket or urn is then brought to the ceremonial room on the upper floor for the funeral.



#### THE ENTRANCE HALL

After passing through the layers of textile in the entrance the visitors arrive at the entrance hall. The room has a double height with an open connection to the upper level. From the entrance hall the visitor can see into the nearby rooms, making it easier to orient themselves in the building. The visitor can see their relatives in the other rooms.

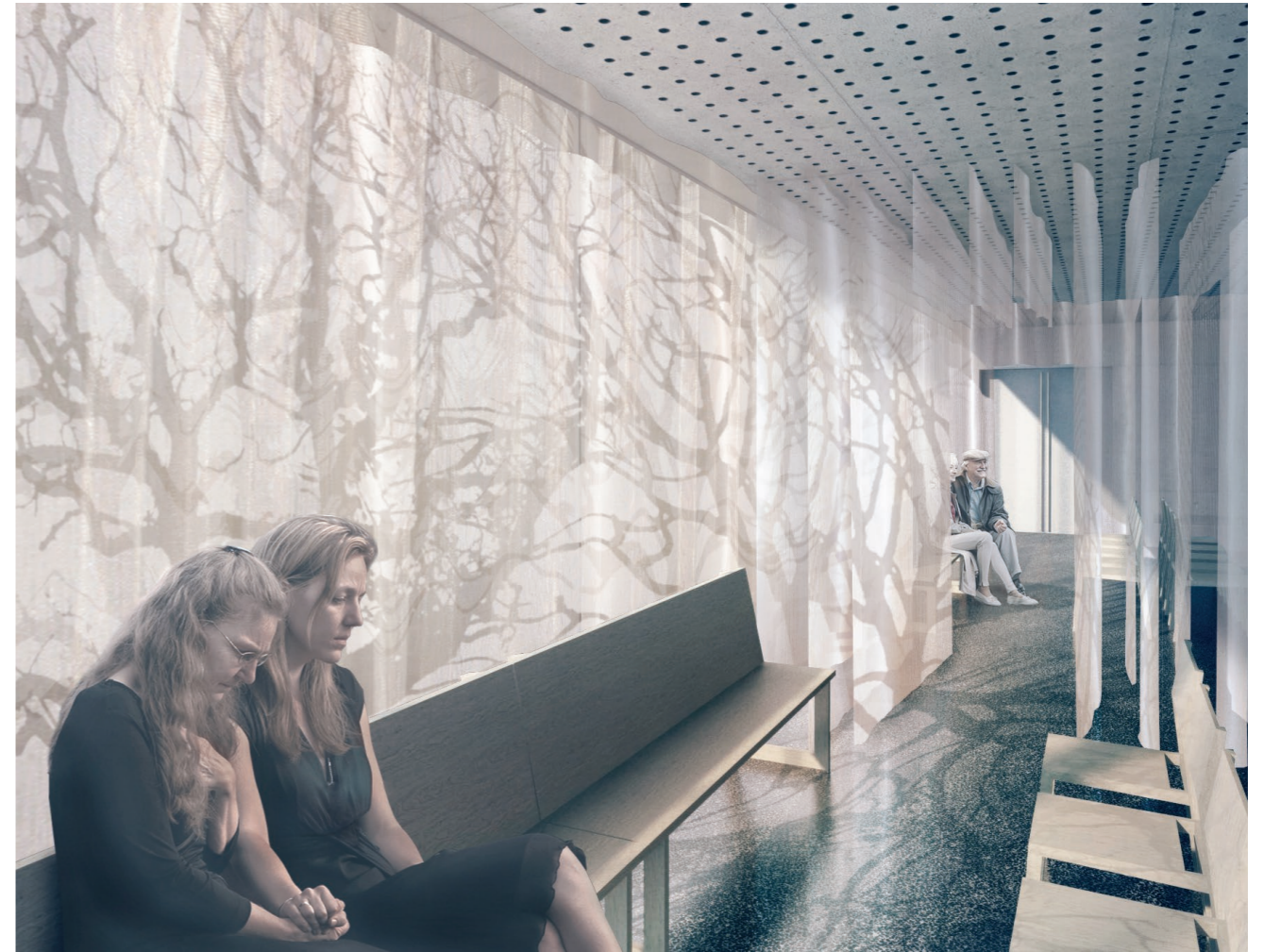

#### THE WAITING ROOM

After leaving their coats in the cloak room the visitors reach the waiting room and meet up with the other attendants of the funeral. The waiting room is divided into smaller parts by the textile but keeping a visual connection. The light from the sun is filtered through the trees, creating silhouettes on the textile.

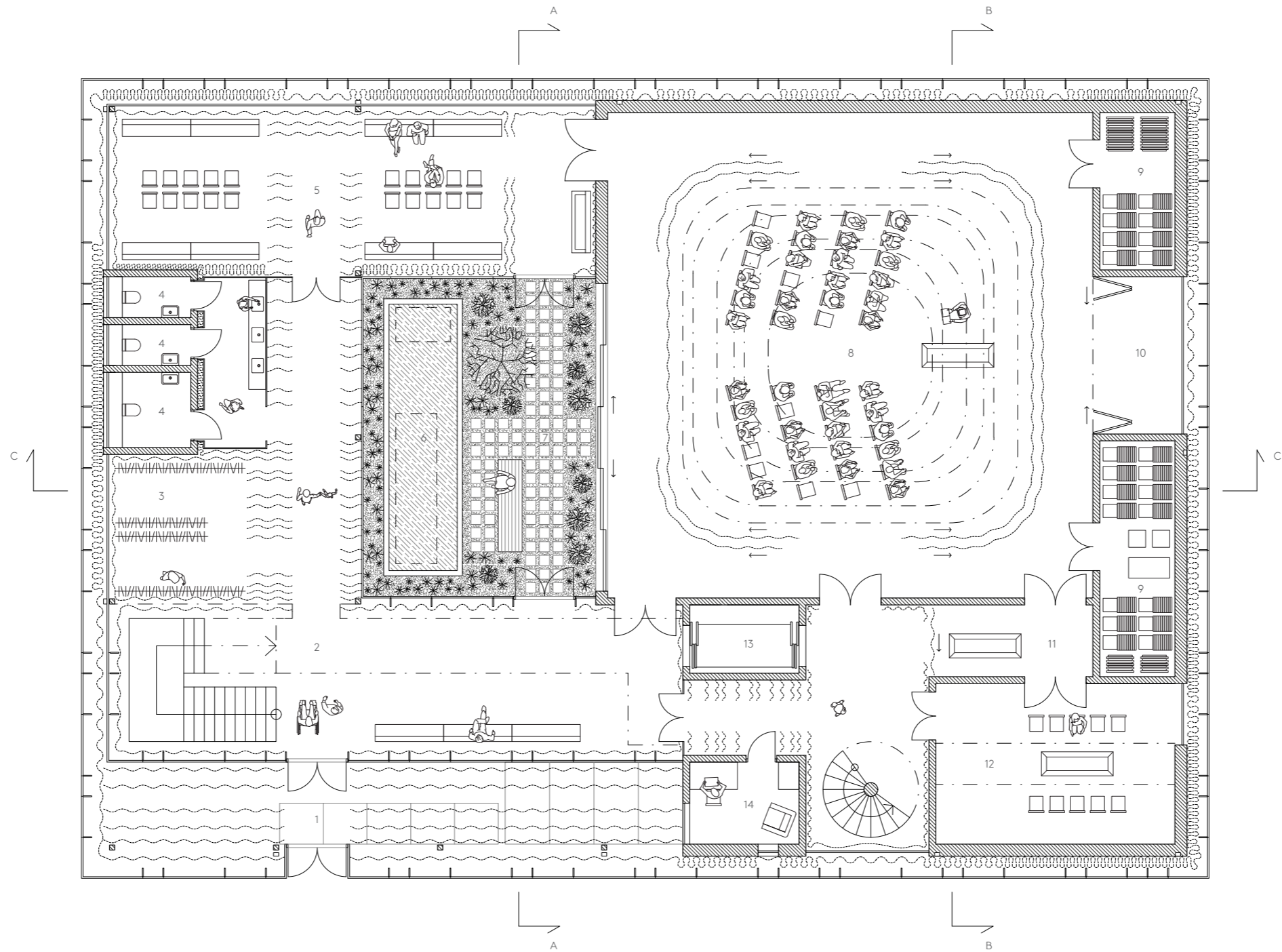

1. Entrance
2. Entrance hall
3. Cloak room
4. Visitor WC
5. Waiting room
6. Water pool
7. Courtyard
8. Ceremonial room
9. Storage
10. Niche
11. Space for casket
12. Room for mourners
13. Elevator
14. Officiant room



#### THE ROOM FOR MOURNERS

If the attendees want to see the deceased before or after the ceremony they can do so in the Mourning room. It is a more private room connected to the ceremonial room and the entrance hall. The ceiling consists of several layers of textile making the room fade out into the sky. The sunlight makes a projection in the shape of the skylight on all the layers creating a volumetric light that changes during the day. The room can also be used to get a break from the funeral, or for smaller funerals if the ceremonial room feels too large.

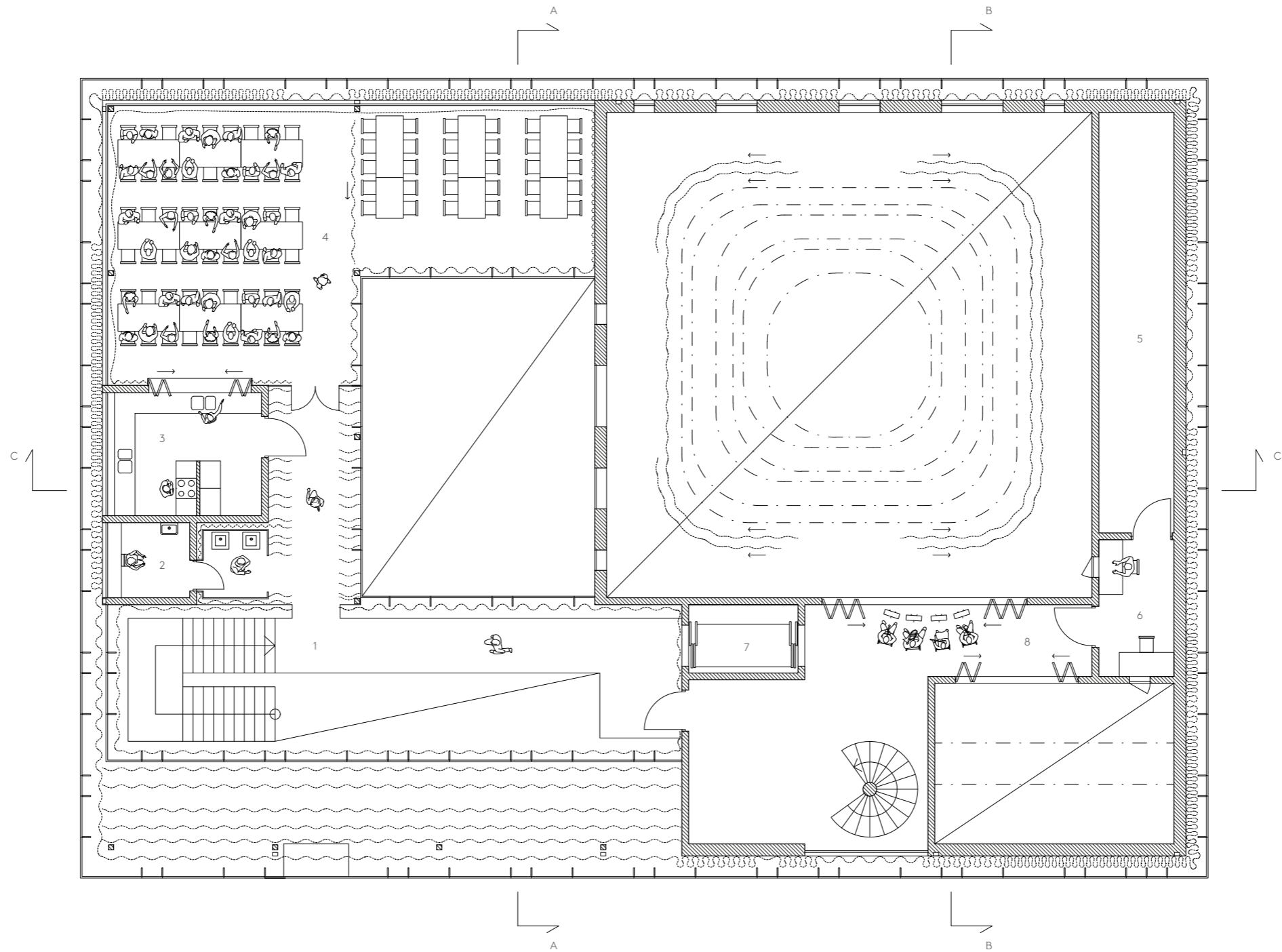

1. Entrance hall balcony
2. Visitor WC
3. Kitchen
4. Dining space
5. Storage
6. Audio/Video room
7. Elevator
8. Music/Choir



#### THE CORRIDOR

The deceased enters the building through the corridor on the basement level. The floor and walls are concrete to withstand the wear. Textile is used in the ceiling to give a softness to the space and is lit with uplights on the walls, reflecting light down into the room. Natural light shines in through the glass ceiling in the end of the corridor.



#### THE PREPARATION ROOM

Before the funeral the casket is decorated and the flowers are prepared. The preparation room is situated in the end of the corridor and is lit from above through a glass floor in the upper level entrance.

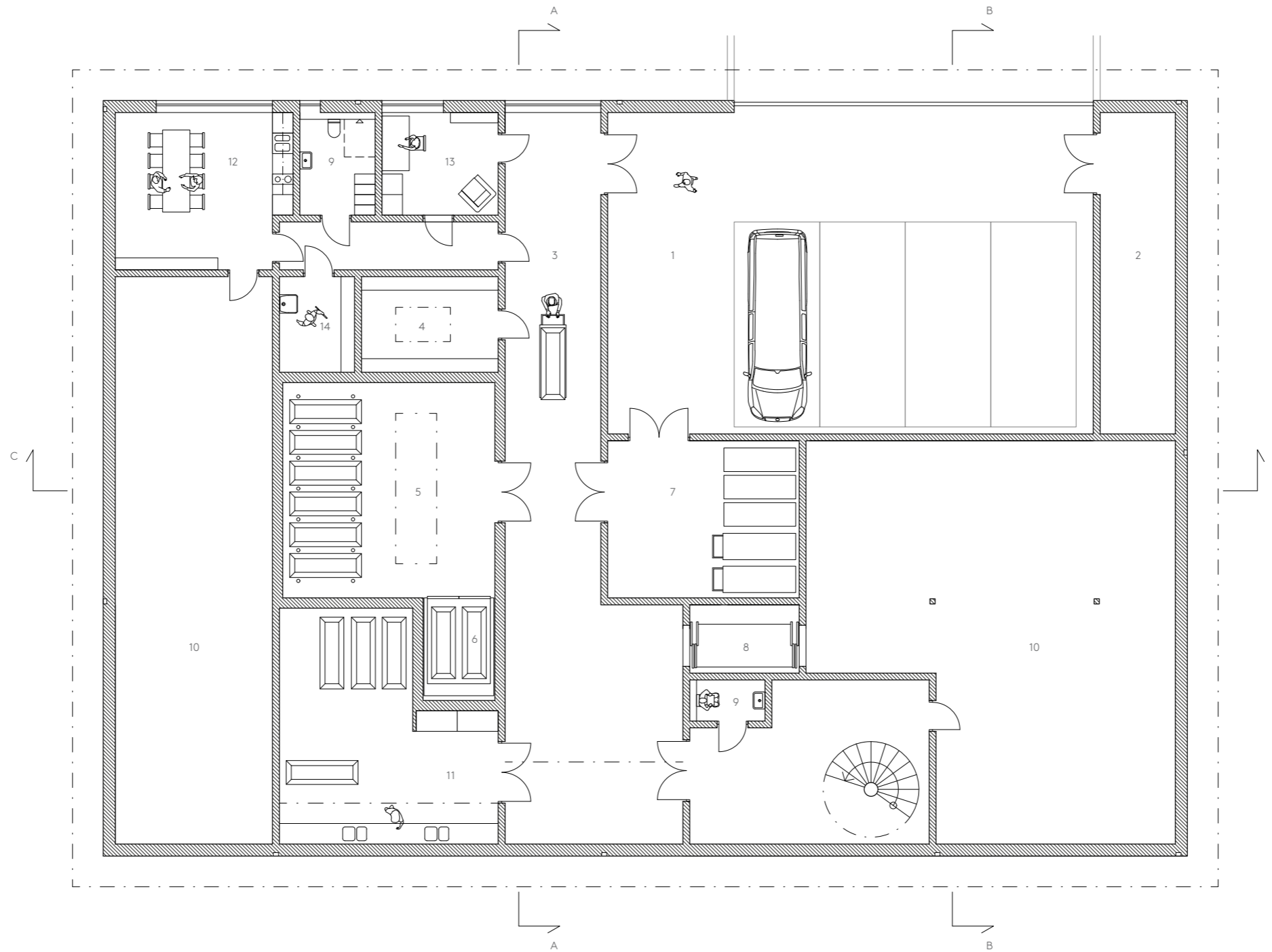

1. Parking/deliveries
2. Storage
3. Casket pathway
4. Urn storage
5. Mortuary
6. Freezer
7. Trolley storage
8. Elevator
9. Staff WC
10. Technical space
11. Preparation room
12. Staff room
13. Office
14. Cleaning room



#### THE MORTUARY

The deceased has their resting place in the mortuary before the ceremony. Light shines into the room from a skylight. The skylight is placed under the water pool in the courtyard, projecting a dancing light on the textile ceiling as the light rays are refracted through the water, giving a calmness to the room.



#### THE URN STORAGE

The urns are stored in a separate room with a similar ceiling like the mortuary. The skylight is placed under the water pool refracting the light onto the textile.

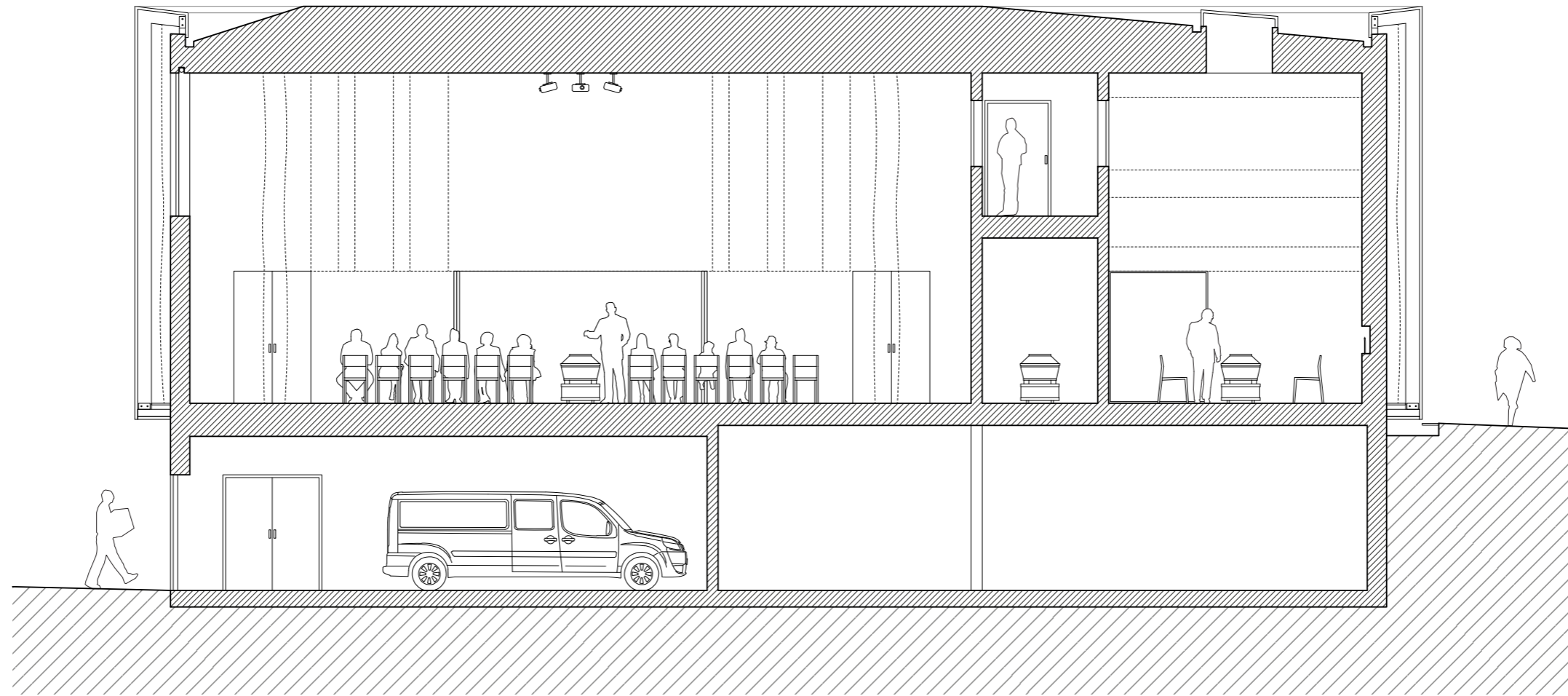



#### THE COURTYARD

A courtyard is placed in the centre of the building with a connection to the nearby rooms. The courtyard brings the light down into the building, sometimes illuminating the textile walls from behind. If the visitors need a pause from the funeral they can go into the courtyard to calm down and feel the fresh air. The water pond gives a calming effect as well as bringing the light down to the level below.

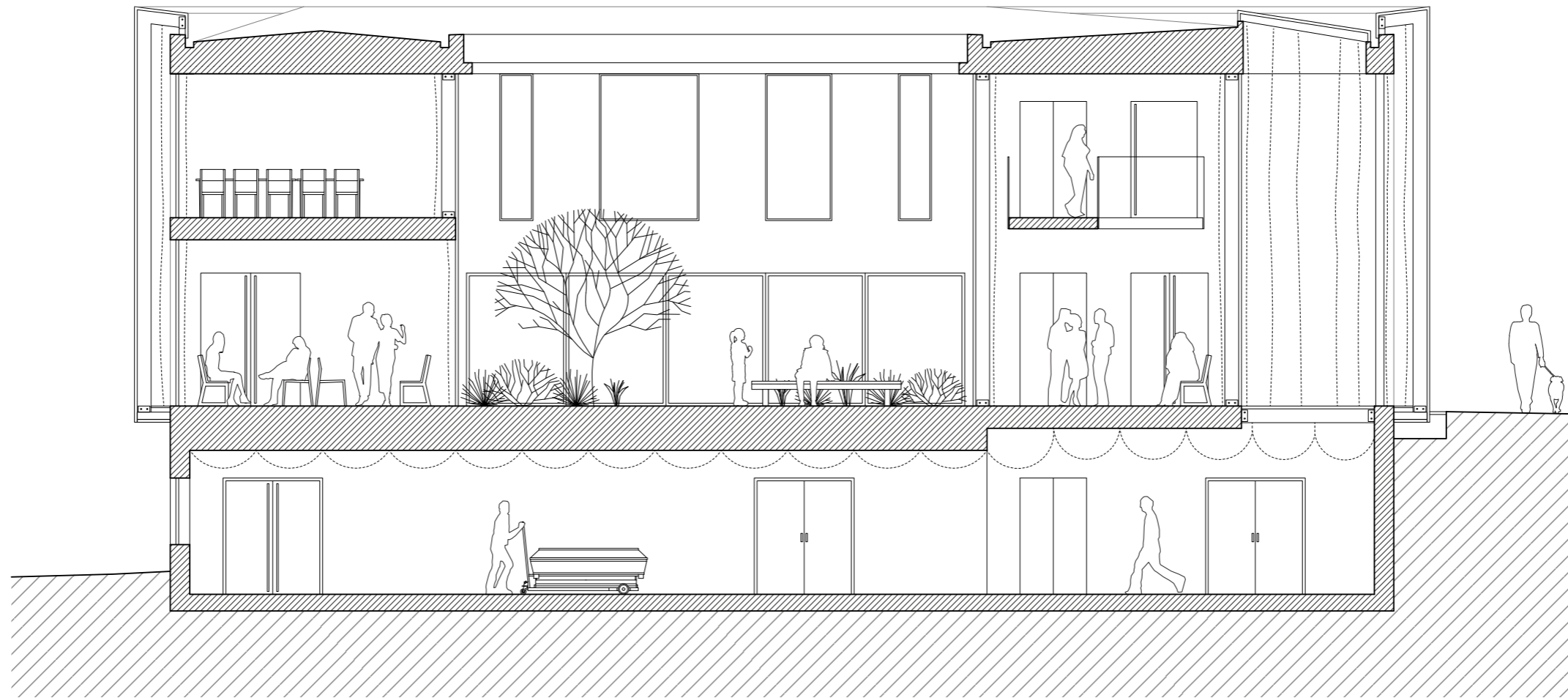

# FLEXIBILITY

An important part of the building is its flexibility. In order for the building to suit the needs of many different people, with different requests and traditions, it needs to be adaptable to many different demands.

The building should be big enough to fit a large funeral without feeling too spacious for the average or smaller funeral.

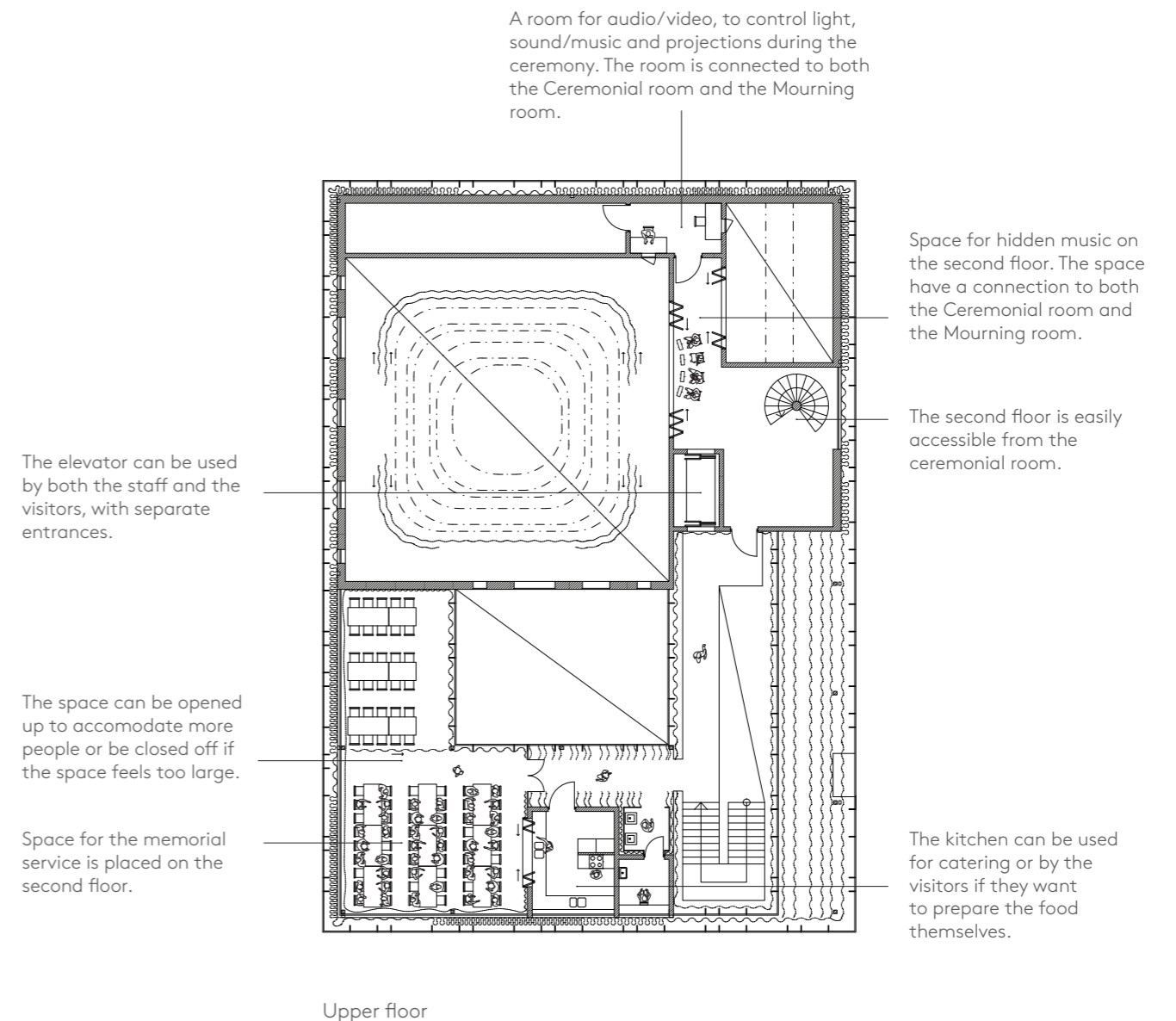
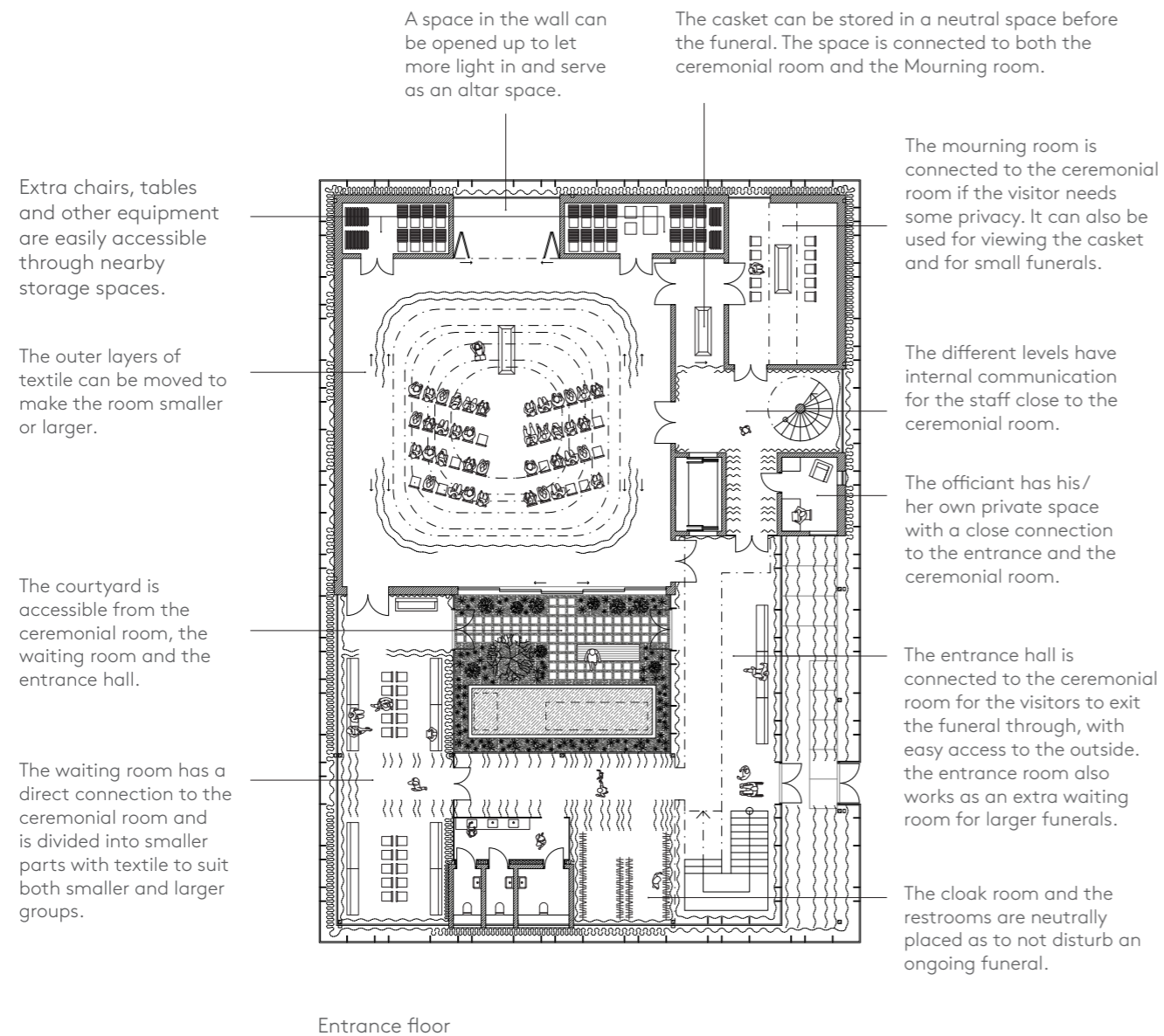

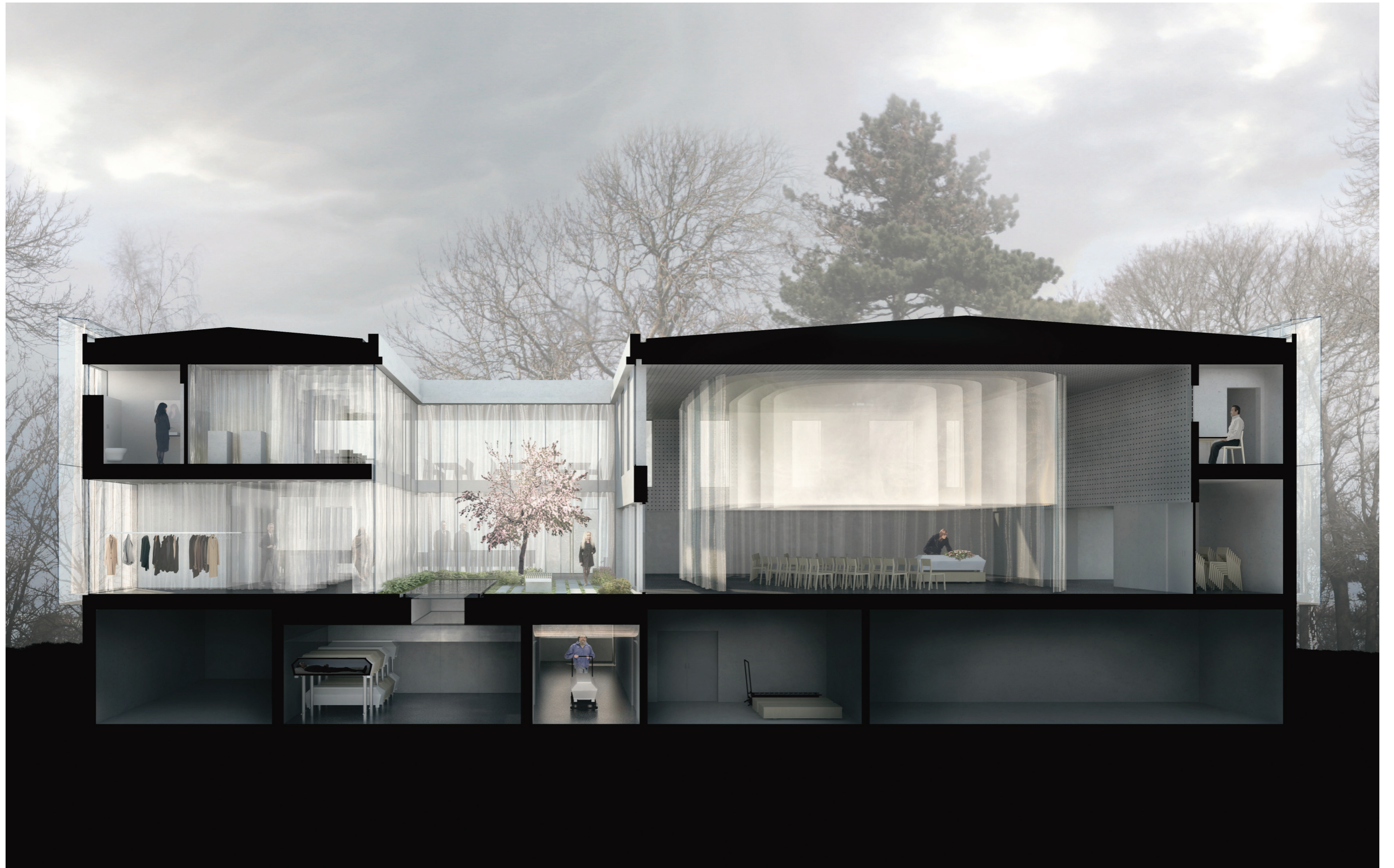

# THE CEREMONIAL ROOM

The Ceremonial room is the core of the building and where the funeral or other ceremonies takes place. Here the textile breaks free from the concrete, leaving space between the textile and the wall. Layers of textile lift from the ground and hovers over the attendants. Light from the high-placed windows or artificial light illuminates the textile making it into a giant chandelier. The outer layers of textile goes all the way to the floor and surround the visitors.

## FLEXIBILITY CEREMONIAL ROOM

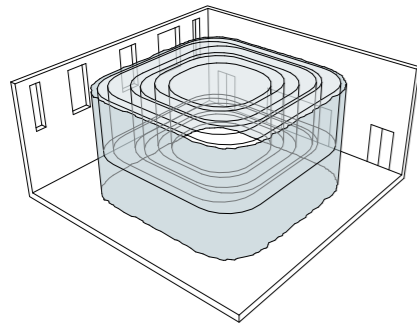

The outer layers of textile can be used to create a smaller room in the ceremonial room with semi-transparent textile drapes.

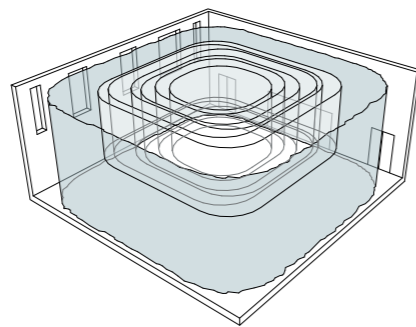

The outer layers can be moved to create a larger room surrounded by textile.

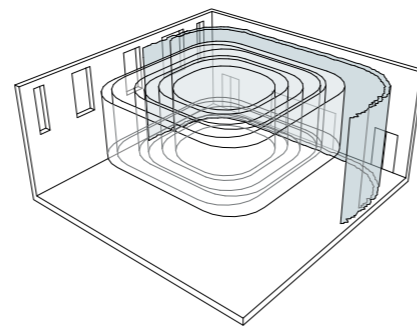

The textile can be moved against the walls if the users wish.

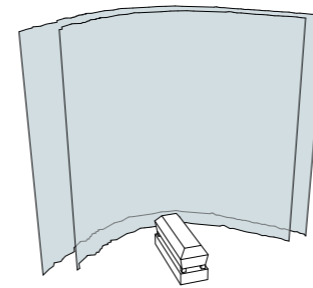

The outer layers of textile can also be used as a backdrop, making it easier to orient the ceremony in whatever direction the users wish.

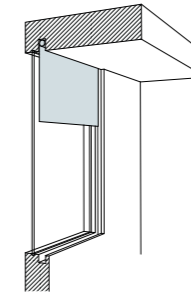

Built-in blinds makes it possible to block out the sunlight and use the artificial light to illuminate the room.

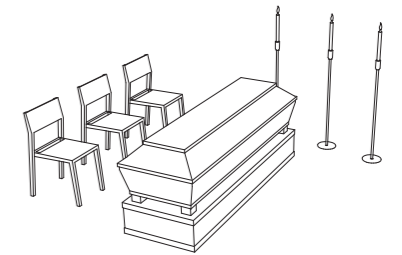

Stackable chairs and no fixed furniture or catafalque makes the room more flexible as the layout can be changed completely.

## DIFFERENT SCENARIOS

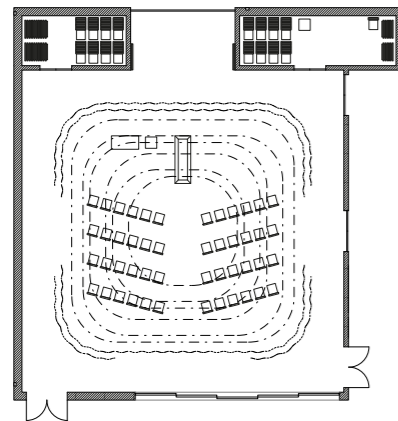

**MEDIUM SIZED FUNERAL**  
The ceremonial room can be used for the average funeral of 40-50 people with a traditional layout.

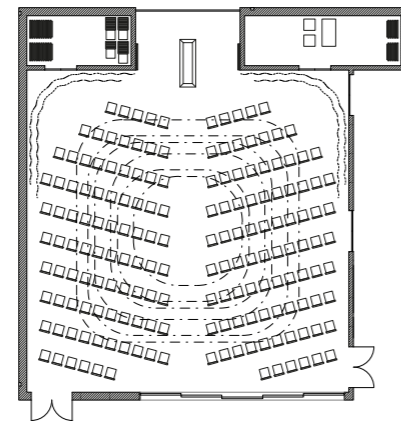

**LARGE FUNERAL**  
The ceremonial room can also be used for large funerals of up to 200 people. The outer layers of textile are moved close to the walls to enlarge the space.

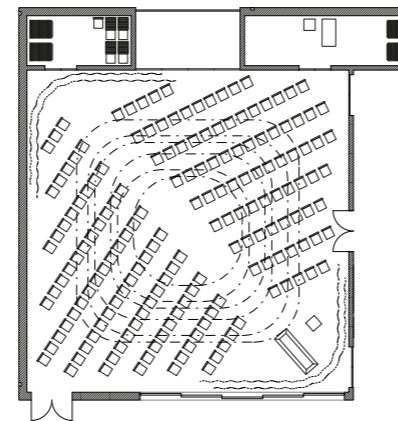

**FLEXIBLE DIRECTION**  
The ceremonial room has no fixed direction and can be oriented as the users wish. The textile can then be used as a backdrop for the casket.

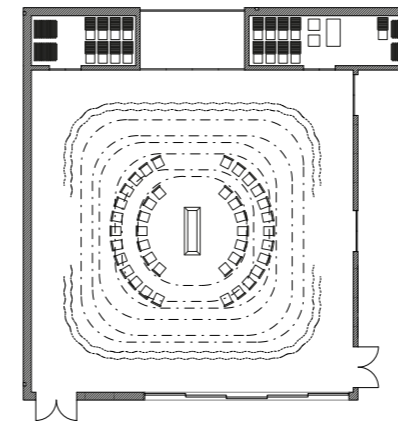

**FLEXIBLE SEATING**  
All furniture in the ceremonial room are movable to accommodate for the different needs and wishes of the users.

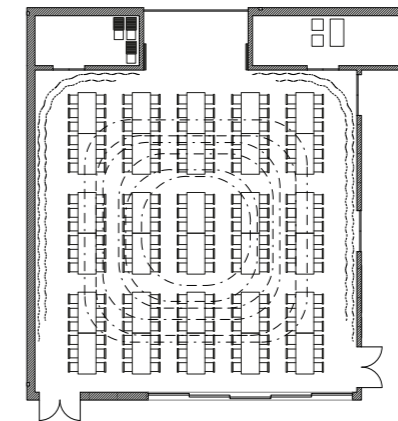

**FLEXIBLE USE**  
The room can be used for purposes other than just the funeral service.

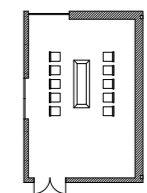

**SMALL FUNERAL**  
The nearby mourning room can be used for smaller funerals if the ceremonial room feels too large.



MODEL 1:100

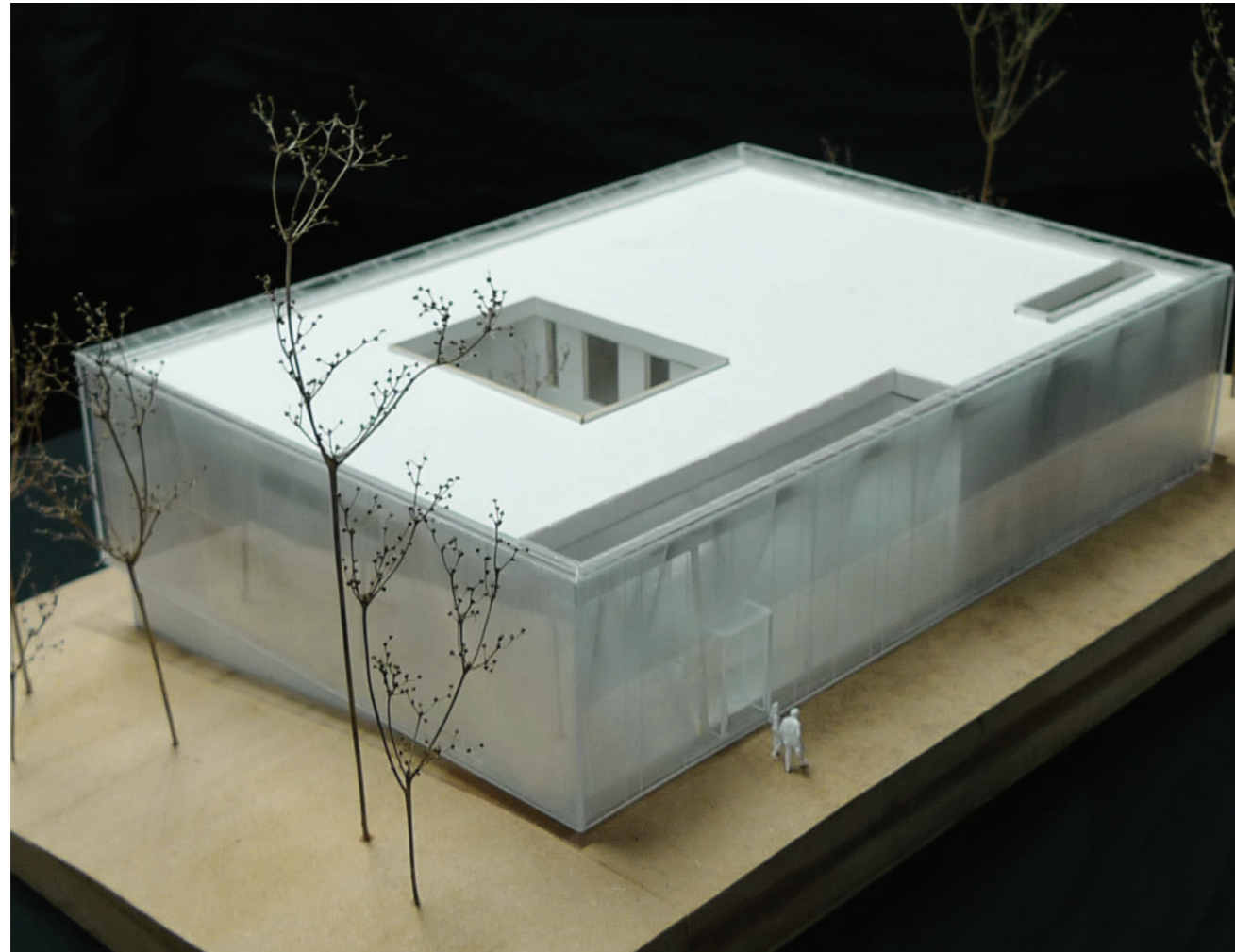

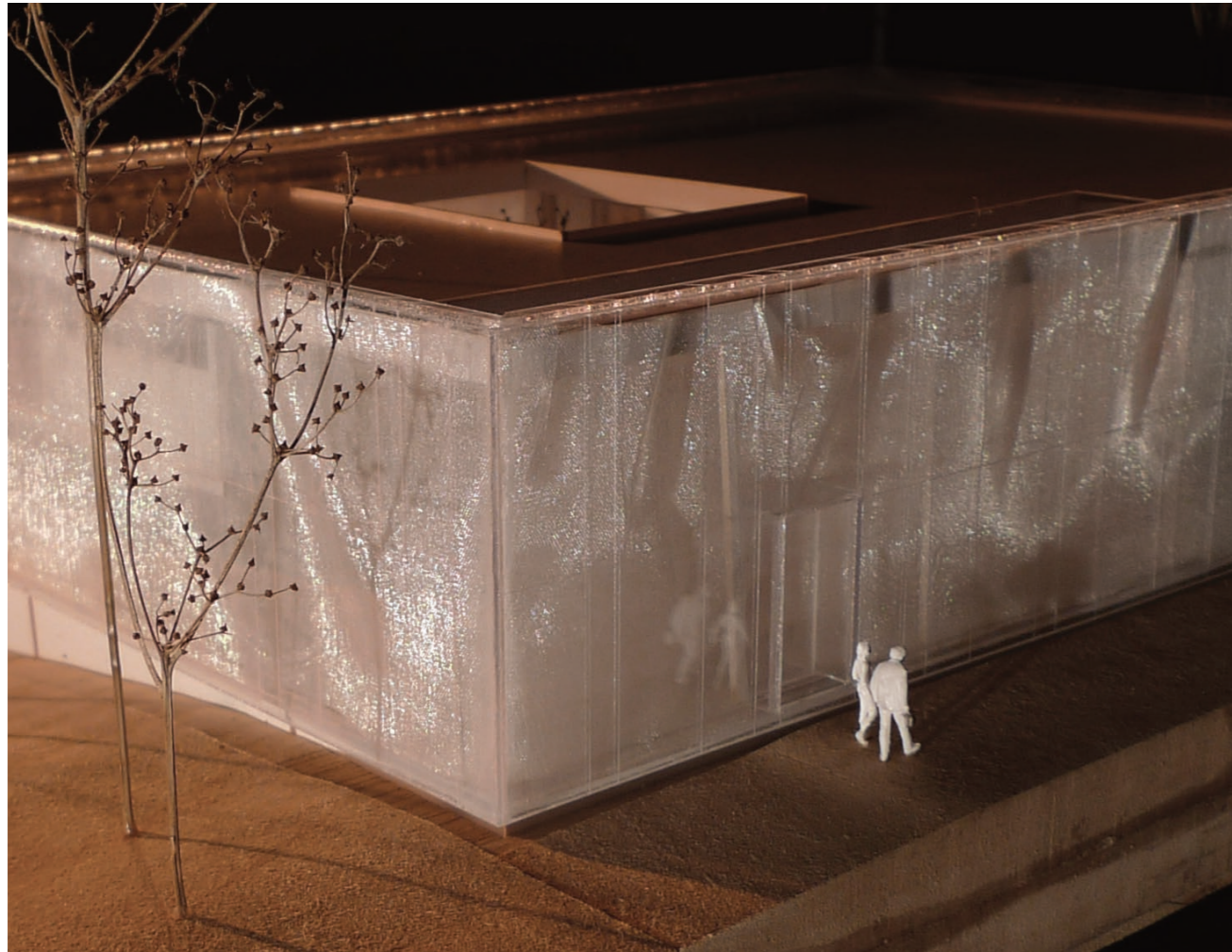

MODEL 1:20

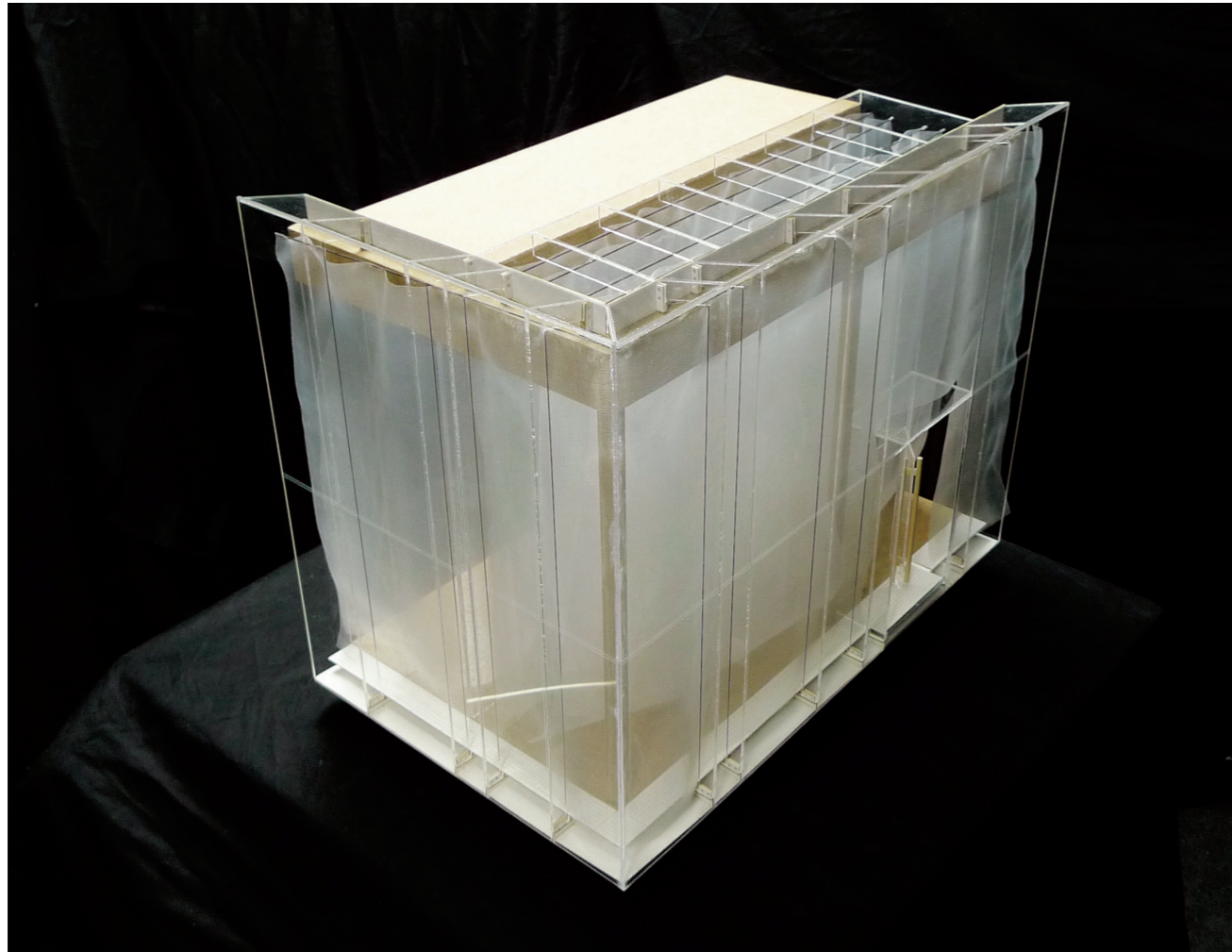

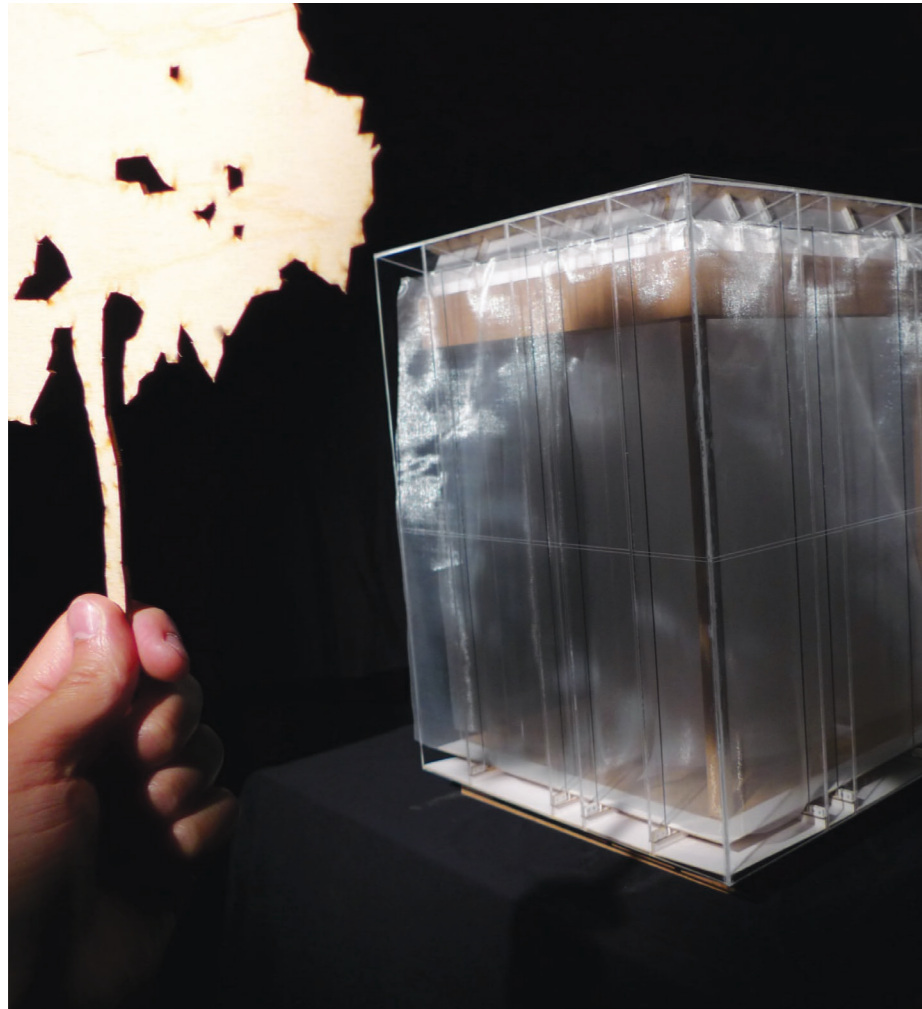



In loving memory of

Asta Bäckström  
1927 - 2014

George Bäckström  
1927 - 2015

