

ANOTHER BRICK IN THE WALL

Embla Jensen



Chalmers School of Architecture
Department of Architecture & Civil Engineering
Examiner: Björn Gross
Supervisor: Mikael Ekegren

Another brick in the wall
Embla Jensen
Master's thesis in Architecture and Urban Design
Spring semester 2021



CHALMERS
UNIVERSITY OF TECHNOLOGY

Chalmers School of Architecture
Department of Architecture & Civil Engineering
Examiner: Björn Gross
Supervisor: Mikael Ekegren

ABSTRACT

We must reduce our carbon emissions in order for future generations to have a decent life on earth. The construction sector accounts for a large part of the emissions and the buildings built today have a short life expectancy. To build is costly, both in terms of effort, money and climate impact. Therefore, it is important to use our resources as qualitatively and long-term as possible.

This thesis seeks one approach for a sustainable way of building new buildings, with the focus on residential brick architecture. Brick is a material that ages well and in many cases brick architecture lasts longer than buildings built in other materials.

Today, brick is used a lot in residential architecture in Sweden, but mainly as cladding, to cover concrete elements or a light structure. The brick only affects the design of the buildings in a superficial way, the detail solutions are not particularly cared for and the possibilities of brick are seldom explored.

The aim of this thesis is to explore and show how masonry could be used in robust heavyweight construction showcasing the inherent materiality and characteristics of brick.

The site chosen in Gamlestaden is a historic setting, surrounded by industrial brick architecture, that has proven to last longer than their initial program. This thesis also explores how to add a new building in an existing urban setting, that can act as a bridge between the old and the new as well as adding value for the people already living there.

The method chosen is “Research by Design”. This means that design iterations in different mediums: sketches, models and pictures etc. is the main tool of investigation.

The result is a detailed proposal of a large residential block in brick in Gamlestaden, Gothenburg.

Keywords: *Brick, Masonry, Gothenburg, Residential architecture*

CONTENT

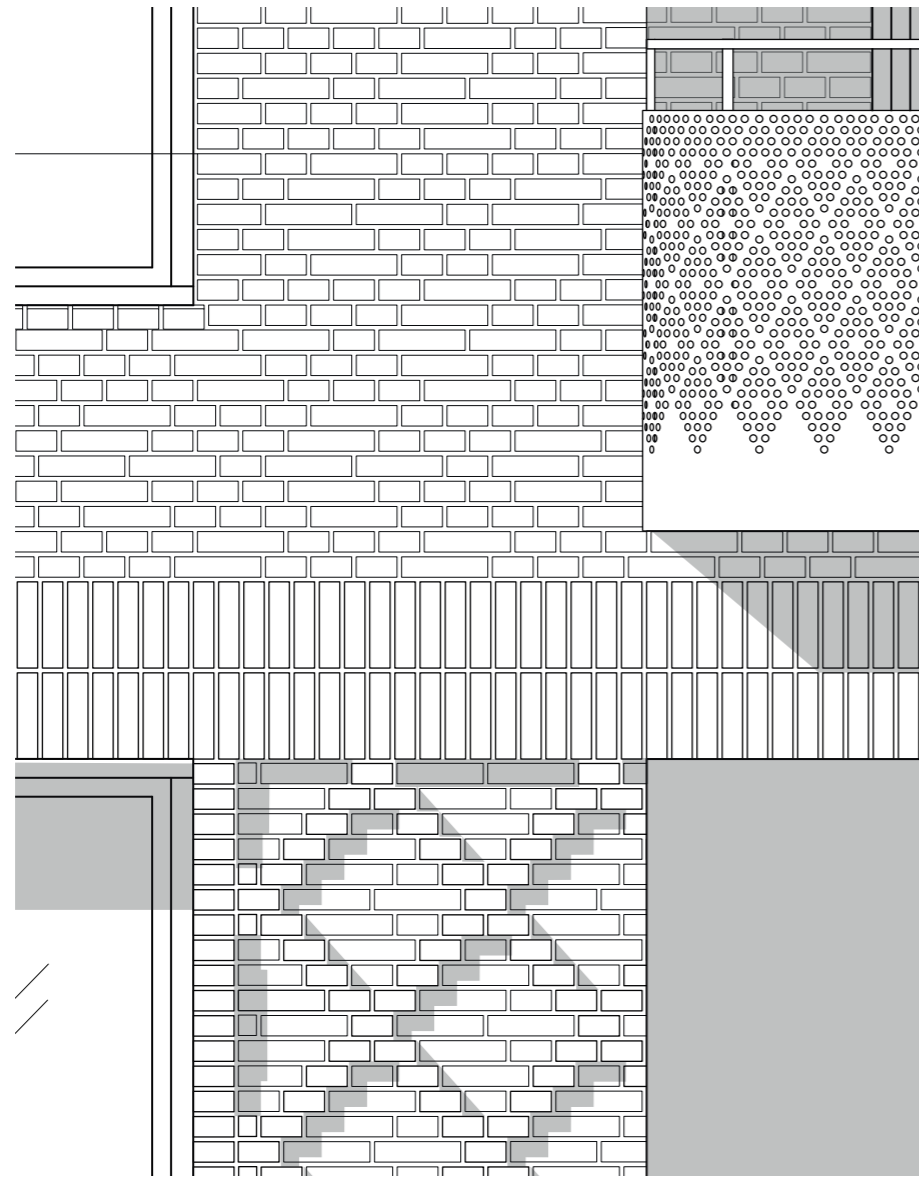

Student background	6
Introduction	8
Background	12
Built references	28
Site	38
Process	56
Conclusions	76
References	79
Appendix, Design proposal	80

ABOUT THE AUTHOR

Embla Jensen

2018

Bachelor degree, architecture
Chalmers University of Technology

2018 - 2019

Internship, BAS ID
Interior architect

2019

Exchange studies, autumn semester
Teaching unit Arroyo Pemjean,
ETSAM, Universidad Politécnica de Madrid, Spain

2019 - 2021

Master programme, Architecture & Urban Design

Matter Space Structure 2, spring 2020

Nordic Architecture, spring 2020

Resistant architecture, spring 2020

Residential healthcare - housing for seniors, autumn 2020

Other

Summer course - From idea to built form, summer 2018



01. INTRODUCTION

Aim and purpose

The aim of this thesis is to explore and show how masonry could be used in robust heavyweight construction showcasing the inherent materiality and characteristics of brick.

My belief is that this also is one answer for how to build sustainable buildings. To make the buildings robust enough to stay functional and liked. Using materials that age beautifully, and detail the building in a way so that it feels taken care of.

Thesis questions

- How can care of detail in a residential building showcase the inherent potential of brick as a material?

Method

This thesis is a research by design project. This means that design iterations in different mediums: sketches, models and pictures etc. is the main tool of investigation.

Reading about masonry construction has also been an important part of the method.

Reference projects has been used through out this project and have been used in order to find examples of architectural qualities that this thesis has been striving for.

Delimitations

This thesis investigates how masonry could be used as a sustainable material, defining sustainability as building with quality, for the long term.

Even though care has been given to different aspects of a building's longevity, the main focus of investigation has been on brick and masonry construction.

The result of this thesis is a detailed proposal of a large residential block, and the focus has been on the design and detailing of the building.



FIGURE 1 *Brickmolds at Horns tegelbruk, Own photograph.*

02. BACKGROUND

THE CLIMATE ISSUE AND THE CONSTRUCTION SECTOR

The construction sector today accounts for between 10-30 percent of Sweden's emissions per year. With the building parts that are produced abroad not included. They in turn account for 12.5 percent of the emissions that Sweden and Swedish consumption create in other countries. The emissions that occurred in Sweden in 2017 amounted to 53 million tonnes, while the emissions that took place outside Sweden's borders from goods and services that we imported amounted to 90 million tonnes in 2017. (Naturvårdsverket, 2020)

In "Roadmap for Fossil-Free Competitiveness: Construction and Civil Engineering" which most of Sweden's major players in the building sector wrote together, the focus is on inventing new technical solutions and materials, as well as to build buildings from recycled materials. But the idea to use buildings for a longer period of time and to rebuild existing buildings is mentioned in a few paragraphs. (Fossilfritt Sverige, 2020)

No building can of course stand forever, even if it escapes the fate of being demolished, all buildings eventually break down anyway. Everyday use and the elements wear on the surfaces of the building, and the underlying material breaks. (Mostafavi, 1993) Even though this is known, buildings have a greater chance of lasting longer if they are constructed of quality materials and built with precision and skill. This is expensive at the time of construction, but pays off in the long run. (Brand, 1995)

The choice of materials are therefore important when it comes to the longevity of the building. The durability of a material varies depending on the specific conditions of the site. But the thickness of the surface exposed to the weather often means better durability. (Mostafavi, 1993) Mostafavi and Leatherbarrow distinguishes in their book two different kinds of material deterioration: "functional deterioration" which makes the material act bad and "aesthetic deterioration" which could make the material look bad, this could be the effects of rainwater collecting soot and dirt at specific areas of the facade. (Mostafavi, 1993) Apart from choosing materials that will not act bad, it is also important to choose materials that will not look bad as they age. Materials like brick, stone and wood age gracefully and their patina is usually considered beautiful, Brand claims (Brand, 1995)

MASONRY CONSTRUCTION

Masonry is a combination of two different materials, brick and mortar, and is therefore considered a composite material. It is most commonly used for constructing walls, both as the load bearing structure and/or as cladding, but is also used in vaults or as floor cladding. (Kummer, 2007) The use of brick is old and developed over a long period of time, in fact, it is one of the oldest manufactured building materials in the world. 4000 years ago bricks were manufactured and used as a building material in the cities on the Indus. Back then the bricks were dried in the sun, but developed to be fired in a kiln. (Kummer, 2007)

Since the tradition hasn't changed that much over the years, masonry has come to symbolise durability and tradition. (Deplazes, 2018) And as Cruickshank writes in his book "Brick" "In this age of ever-increasing concern over ecology, sustainability and energy conservation, bricks - with their long-life span and splendid insulation characteristics - remain an ideal building material." (Hall & Cruickshank, 2015, p 13)

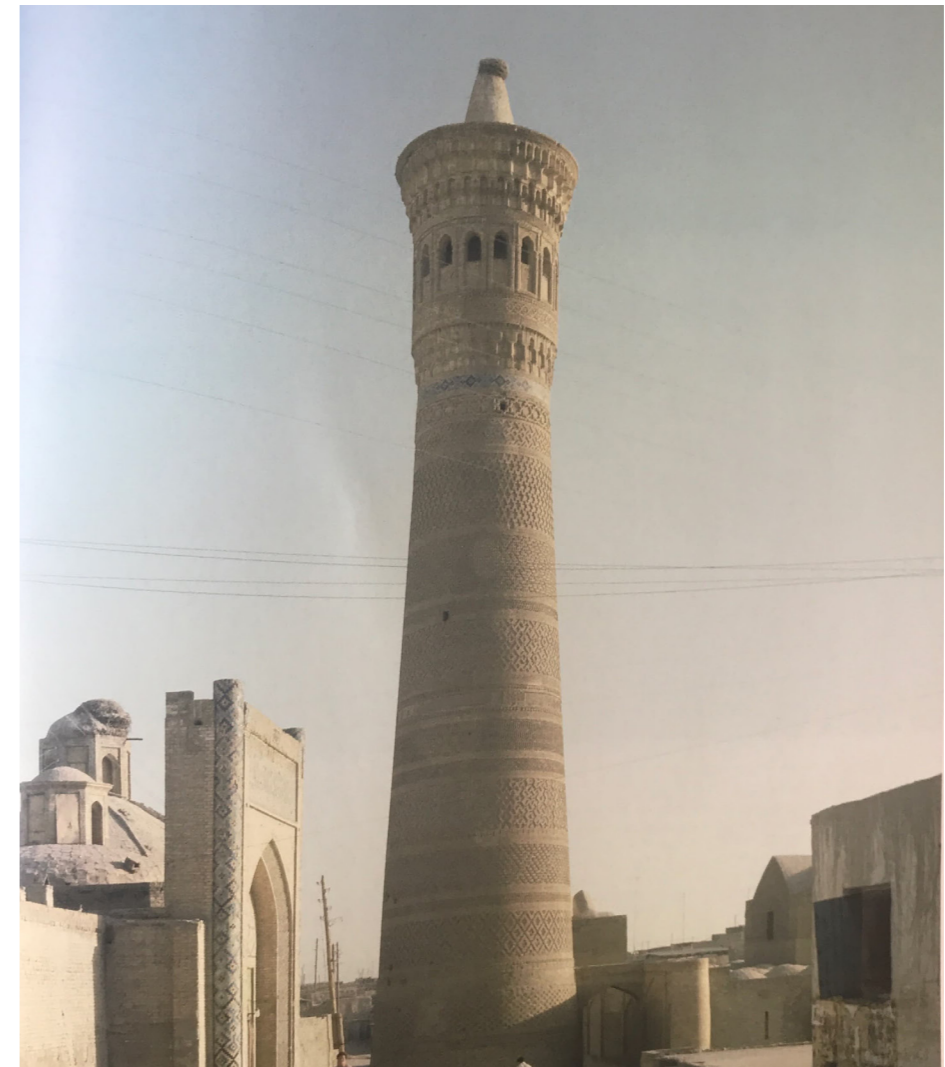

FIGURE 2 *Minaret, The Bukhara mosque from 1127*
(Hall & Cruickshank, 2015, p 191)

BRICK

Brick is made of loam and clay, that is later pressed either into a formwork or into a ribbon and cut and lastly fired in a kiln. (Kummer, 2007) They come in many different formats and the shape and size of the particular brick create a ruleset that helps decide the size and height of rooms and buildings as well as the placement and size of openings. (Kummer, 2007)

MORTAR

The mortar is as important as the brick. It helps the brick to cover a larger area and makes the brick hold together. (Kummer, 2007) The colour and the finish of the mortar also has a large impact on the appearance of the masonry. The joint can be protruding, recessed etc, the joints can also be thicker or thinner, all of this creating different expressions. (Deplazes, 2018) The mortar is put both horizontally (course joint) and vertically (perpend joint) in between the bricks. (Kummer, 2007)

COURSES AND BONDS

The rows in masonry construction are named courses. Stretcher courses and header courses are used together and form bonds. (Kummer, 2007) The stretchers and headers can also be used together on the same course, creating an almost endless number of bonds. (Deplazes, 2018) Soldier courses and edge courses are not as fragile as horizontal bricks and are for example often used as lintels. The courses are then laid upon each other with an offset of $\frac{1}{4}$ brick length or more. (Kummer, 2007)

It is possible to use the bond for ornamentation, for example to use different coloured brick, and through that create a pattern on the wall. The possibility to protrude certain stones within the bond also makes it possible to ornament the building with the help of shadows and relief. (Deplazes, 2018)

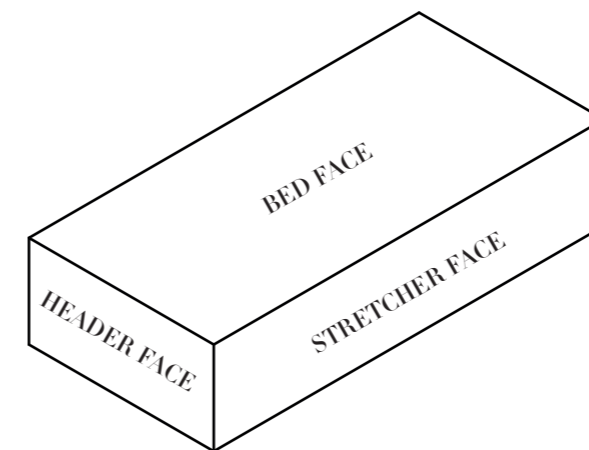

FIGURE 3 *Standard brick*
(Kummer, 2007, p 9)

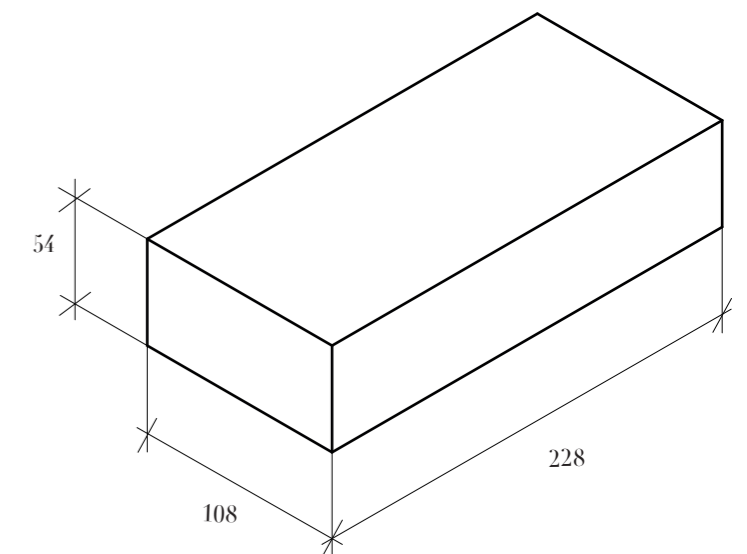

FIGURE 4 *Danish brick (mm)*
Own diagram

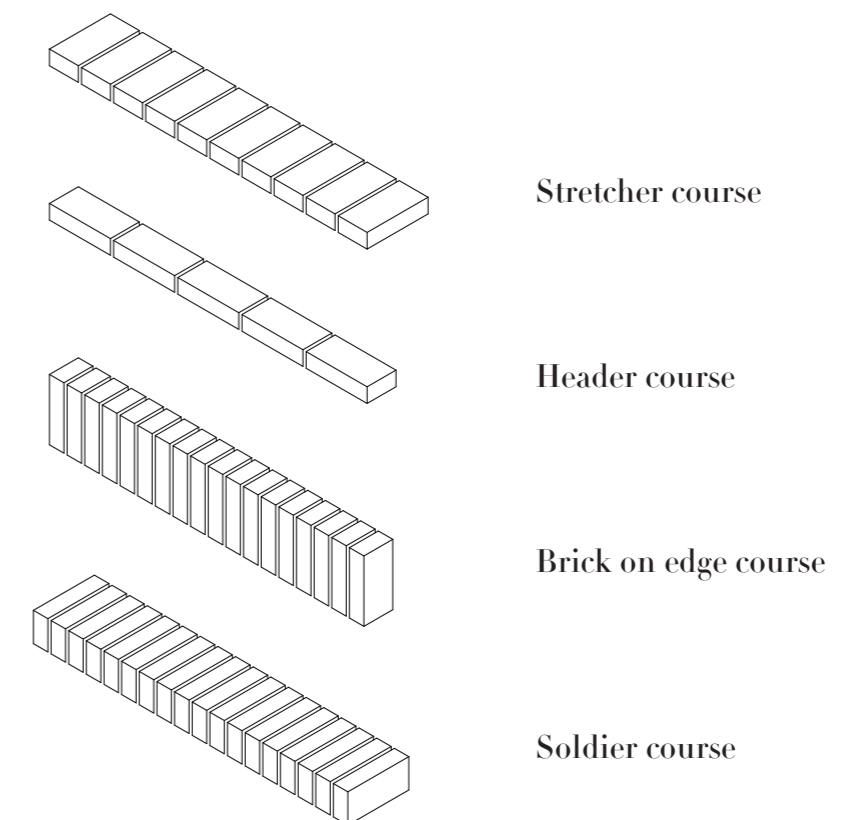

FIGURE 5 *Brick courses*
(Deplazes, 2018, p 32)

THE MODULE OF THE BRICK

While designing a masonry building the module of the brick could be used, in order to minimize material loss and use as many whole bricks as possible. Since masonry is a combination of both brick and mortar, it is a little bit more tricky than just using a grid. (Kummer, 2007) In order to explain that Kummer (2007) breaks it up into nominal dimension and specified dimension. When using a building material without joints, these dimensions are the same, but they differ in masonry construction. (Kummer, 2007)

The nominal dimension = brick dimension

The specified dimension = nominal dimension + joint

Because of the joints, the dimensions of the walls between windows and the dimensions of the window openings differ, since the opening has one more perpendicular joint and the walls between the opening has one missing joint, but these joints balance each other out. (Kummer, 2007)

The module of the brick of course varies with the size of the brick and joint, (Kummer, 2007) and the theoretical dimensions of the brick is not as exact in reality. (Tegelmäster, n.d.)

In Denmark, a module is used to help merge reality and theory and avoid mistakes. While using a danish brick format, the specified dimension of the brick is 240 mm lengthwise (nominal dimension + joint = 228 + 12) and the specified dimension of three courses is 200 mm in height ($3 \times \text{nominal dimension} + 3 \times \text{joint} = 3 \times 54 + 2 \times 13 + 1 \times 12$) (Tegelmäster)

But the module of danish brick that is commonly used by a mason is a module in height of $2M = 200$ mm, and a lengthwise module of $3M = 300$ mm. Which makes it possible to make up a module of 600 mm x 600 mm. (Murerbogen, 1995)

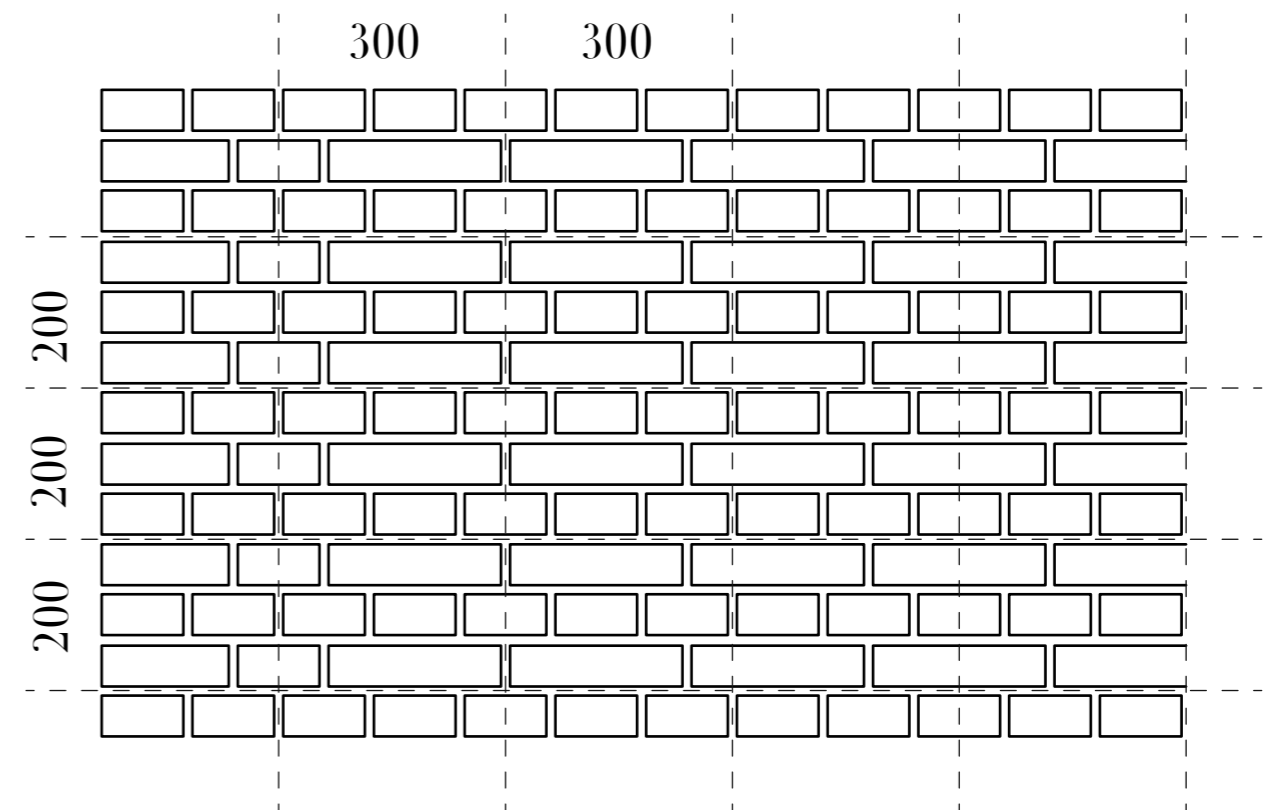

FIGURE 6 *The module of danish brick (mm)*
(Murerbogen, 1995, p 53)

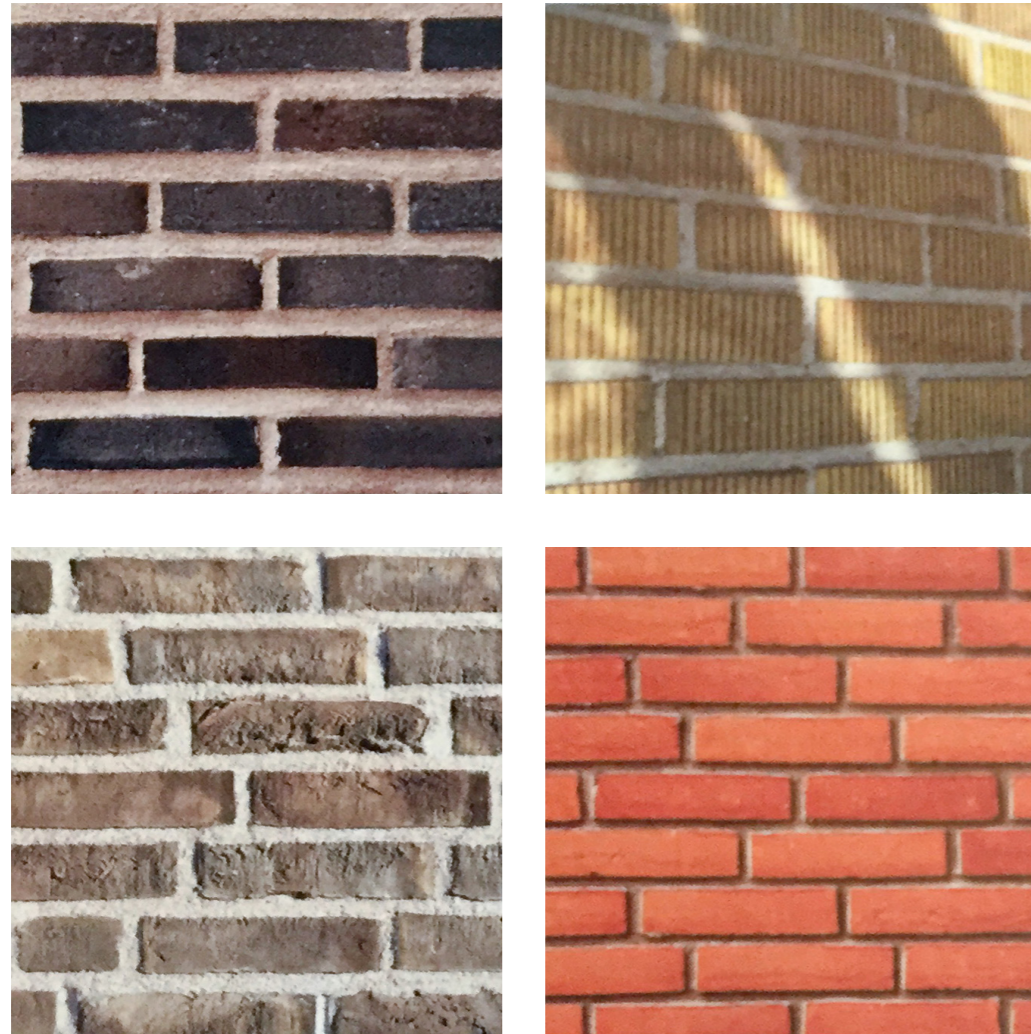

FIGURE 7 *Different colours of brick.* (Gustavsson, 2008, p 39)

THE COLOUR OF THE BRICK

The colour of the brick and mortar is an important design feature. The colour of the brick is dependent on three factors: 1. the clay used, 2. the type of sand, engobes or pigment used on the surface of the brick, and 3. the environment in the kiln. (Vandersanden, n.d.)

The clay used in the brick affects the colour of the brick because of the different metal oxides in the clay. Clay containing iron oxide gives us red brick, lime gives yellow brick and manganese oxide creates a brown brick. (Vandersanden, n.d.) This makes it possible to connect the building with the site, by using the local clay. The surface of the brick can also be treated with different engobes or pigments, which also affect the colour of the brick. (Vandersanden, n.d.)

The environment in the kiln refers both to temperature and how much oxygen that is available. If the brick is fired at too low a temperature, it will not be hard enough, and if it is fired at too high a temperature it will shrink more, (Vandersanden, n.d.) bricks fired at higher temperatures are also more resistant to frost and water. (Deplazes, 2018) Different types of clay have their own ideal firing temperatures. (Vandersanden, n.d.)

The availability of oxygen in the kiln also affects the colour, as the oxides in the brick reacting to oxygen is what creates the colour. An excess of oxygen with different types of clay gives us red, yellow or brown brick. When the access to oxygen is reduced in the kiln, the oxides instead lose oxygen, which gives us light brown, grey and green brick. (Vandersanden, n.d.) The brick can also be braised, which means that a brick that is already fired is placed in the kiln once again, and when the kiln reaches approximately 950°C the oxygen access is cut off. This means that the brick is put in an environment with less oxygen during a longer period of time. A red brick will then turn dark grey and a yellow brick light grey. (Gustavsson, 2008)

STRUCTURE

Brick and mortar together make up the load bearing capacity of the masonry structure. It is better at handling compressive forces than tensile or tensile bending forces. When brick and mortar is pressed together from above stress is produced at the places where brick and mortar meet. This leads to compressive stress in the mortar and tensile stress in the brick. If the load is too great for the structure the mortar will cave in and the brick will crack vertically. (Kummer, 2007)

In a traditional masonry structure the wall was massive, constructed of brick and mortar all the way through. This is no longer possible due to the increased requirements on insulation and thermal qualities. (Kummer, 2007)

Today brick is mostly used as a cladding, and creates the facade and the buildings shell against the weather. It has lost its role as the main load bearing element, but still has to carry its own weight, as well as the wind forces. (Gustavsson, 2008)

The load bearing structure behind a brick facade today in Sweden is often either a timber stud construction or a concrete wall. (Gustavsson, 2008) In the case of timber stud construction, Gustavsson (2008) claims that the users of the house will notice that the walls are not massive as they should have been if the house was built out of brick. In the case of a load bearing back wall of concrete, this problem with credibility doesn't exist in the same way, as concrete is also a massive material. (Gustavsson, 2008) But brick and concrete expand differently with the temperature, which can make the brick facade crack. (Gustavsson, 2008)

Gustavsson (2008) also writes about the importance of the details where the different materials meet each other. Today, he writes, it is common practise to put sheet metal over the meeting in windows, to hide it. But it is also possible to let the brick continue to the window, in that case the metal is not needed and the mirage of a massive brick wall is more credible. (Gustavsson, 2008)

But there are ways of constructing the load bearing structure in brick today. Gustavsson (2008) writes about several different wall types, where two leafs of masonry is connected with either wire anchors (Double leaf masonry wall) or brick (Diaphragm wall). Between the inner and outer leaf insulation is placed, which makes the wall live up to the energy requirements of today. (Gustavsson, 2008)

In cases where the load is greater, there is also a possibility to construct a masonry wall where the outer leaf is made out of brick, while the load bearing inner leaf is made out of autoclaved aerated concrete or masonry blocks. The inside of the wall is then plastered, which both contribute to the airtightness of the wall, as well as making it possible for the user to paint the walls to their liking. (Gustavsson, 2008)

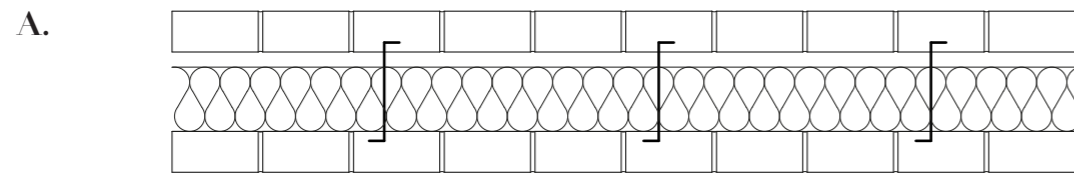

DOUBLE LEAF MASONRY WALL

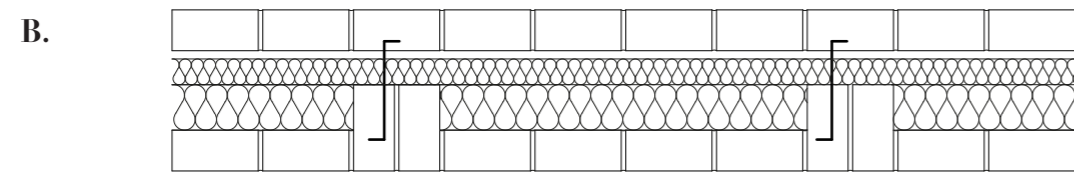

**DOUBLE LEAF MASONRY WALL
with butresses**

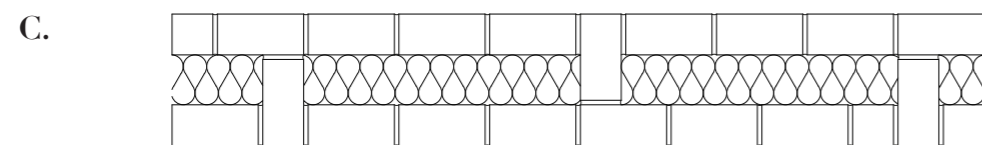

DIAPHRAGM MASONRY WALL

FIGURE 8 *Wall types (Gustavsson, 2008, p 78)*

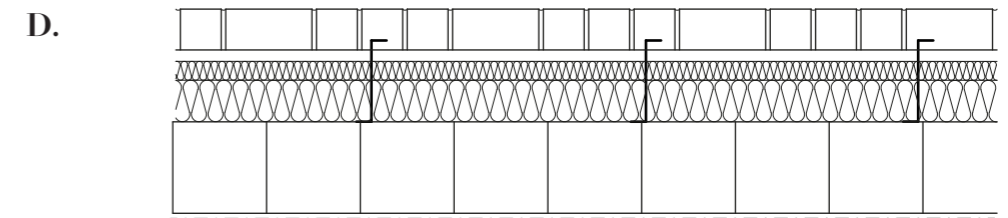

**DOUBLE LEAF MASONRY WALL
with masonry blocks**

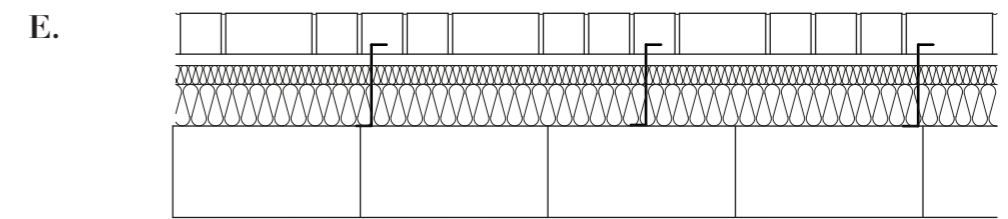

**DOUBLE LEAF MASONRY WALL
with autoclaved aerated concrete**

FIGURE 9 *Wall types (Gustavsson, 2008, p 87)*

- A. Is the wall that is most commonly used in smaller residential buildings, with brick as the load bearing structure. (Gustavsson, 2008)
- B. Could be used when the load is greater. (Gustavsson, 2008)
- C. Takes more loads than wall A and B, but is not as good from an insulation and energy standpoint. It could be used in buildings where that is not as important as in residential buildings. (Gustavsson, 2008)
- D-E. These wall types are suitable when the load is greater, as for higher residential houses. (Gustavsson, 2008)

03. BUILT REFERENCES

LARGE YARD RESIDENTIAL BLOCK



FIGURE 10 *Hornbaekhus, Copenhagen, Kay Fisker. Photocredit: Wikimedia commons*

Hornbaekhus designed by Kay Fisker is located in Copenhagen. It is in an enormous block built out of brick, with repetitive and calm facades. The yard becomes almost like a private park for the residents. This block is several times bigger than the block that this thesis suggests, but the qualities of the big yard and the calmness of the building's facades has been an inspiration.

ENFILADE

Z33 in Hasselt Belgium by Francesca Torzo is a project where every detail is well thought through, nothing is left to chance. It is not traditionally minimalistic, yet it has an elegant air of simplicity to it. Both the facades and the ceilings have a relief, which creates a play of shadows and light. The enfilade along the plastered brick wall creates a sequence and is meant to be a quiet walk.



FIGURE 11 Z33, Hasselt Belgium, Francesca Torzo, Photocredit: Bianca Maggio

RELIEF



FIGURE 12 *Wolf House, Aggstall, Hild & K architects*
(*Deplazes, 2018, p 42*)

Wolf house by Hild & K architects is situated in Aggstall, Germany. The facade consists of brick that is covered with a thin layer of white plaster. The brick has a pretruding pattern, which creates a geometric play of light and shadow on the facade. The materiality of brick has clearly put its mark on the project, where the bond continues seamlessly around windows and corners. The relief makes the building feel detailed and taken care of, yet simple.

PERFORATED MASONRY

The Kolumba museum by Peter Zumthor protects the ruins of a church and several older buildings. Both merging with them and covering them. The perforated brick wall lets in indirect light that changes during the day. The blurred light creates an almost underwater feeling, and this contributes to the sacral atmosphere. Wind and air passes through.

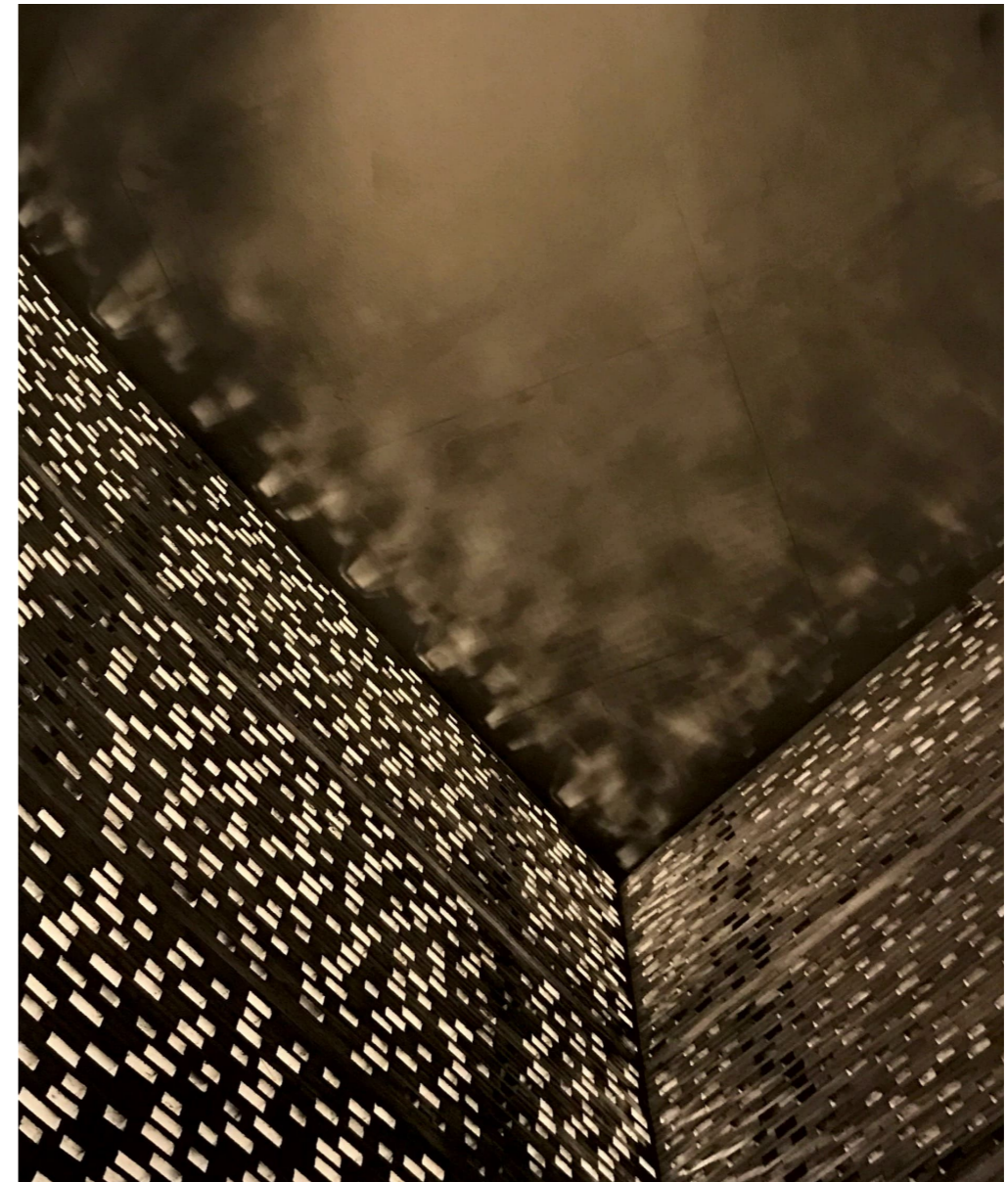

FIGURE 13 *Kolumba museum, Köln, Peter Zumthor.*
(Hall & Cruickshank, 2015, p 137)



04. SITE

FIGURE 14 *Gothenburg*

SITE

The site is located on a parking lot next to the SKF complex, in Gamlestaden, Gothenburg.

Gamlestaden is located 3 km northeast of the the city centre of Gothenburg, but is still an urban district of the city.

The built environment around the site is mixed and has been developed under a long period of time.

Older industrial buildings in brick, like Gamlestadens factories (built between 1729-1940) and SKF's oldest building: A-factory (built 1907-1913) is mixed with Landshövdingehuset in wood and brick from 1915-1930. There is also buildings from around 1960, like SKF's office building in 10 stories (from 1967) and the citizens' house (from 1957). There is also some modern additions, a house on Holländarplatsen built in 2015 in brick and glass, and a newly developed area around Gamlestadstorget. At the moment Gamlestaden is undergoing a large city-development, with lots of new buildings planned and under development.



FIGURE 15 *The site towards SKF. Own photograph.*



FIGURE 16 *Säveån. Own photograph.*



FIGURE 17 *The surrounding buildings. Own photographs.*

STREETS

Gamlestadsvägen passes the area. Today it is highly trafficed, but will be turned in to a boulevard in the future.

Artillerigatan is the most trafficed street apart from Gamlestadsvägen. The restaurant, shops and other businesses in the area is mainly located towards this street. Today Artillerigatan breaks up the area, since it is highly trafficed by both trams and cars and is hard to cross. The plans today is to turn it into a boulevard.

Hornsgatan is a calmer street, with an important axis, from Sävån to Holländareplatsen.

Sävåns strandgata/Kullagergatan runs along Sävån and is not used that much today. In the future it could be a green promenade along Sävån.

Banérsgatan is a one way street today and is not connected to Artillerigatan or Sävån.

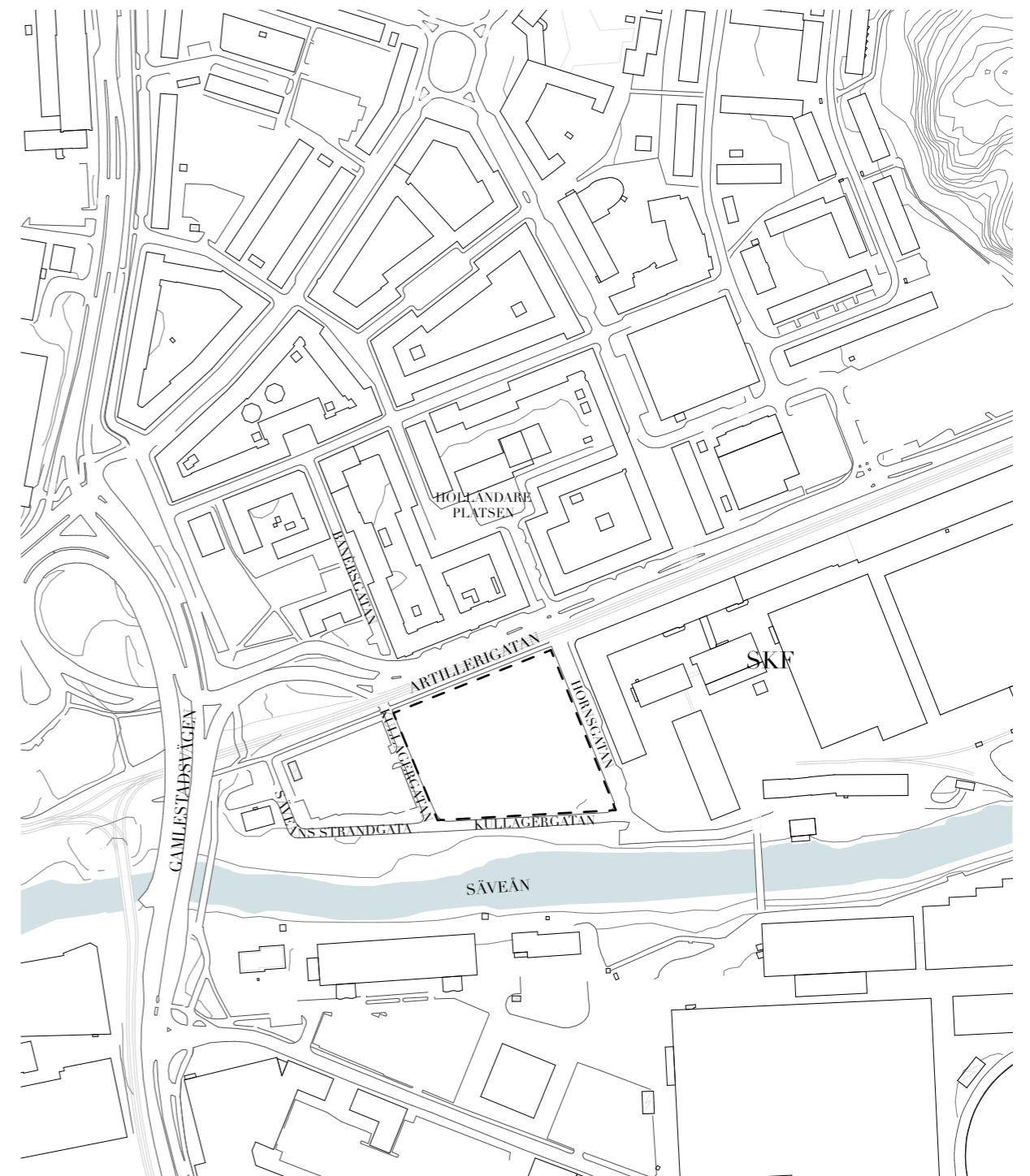

Siteplan (current state)
Scale 1:4000

HISTORY

Gamlestaden has a long and rich history.

Between 1473-1621 the city Nya Lödöse was located here. When Gothenburg was founded in 1621, Nya Lödöse lost its city rights and the citizens moved to the new city. (Bjur & Engström, 2018)

Gamlestaden became a rural part of the city of Gothenburg and the land was used for farming by the different Landerier that was founded around Gothenburg. (Bjur & Engström, 2018)

The next big step in Gamlestadens history is based on its industries. Sahlgrenska Sockerbruket (later Gamlestadens Factories) was the first industry started on Landeri Ånäs (1729), by the family who was running the Landeri.

In 1854 Sahlgrenska Sockerbruket was bought by another industrialist and turned into a textile factory. At the time it was one of the biggest industries in Europe.

An engineer who worked at Gamlestadens Factories, Sven Wingvist, invented the self-aligning ball bearing that was the start of SKF. (Det gamla Göteborg, 2019, 11 november)

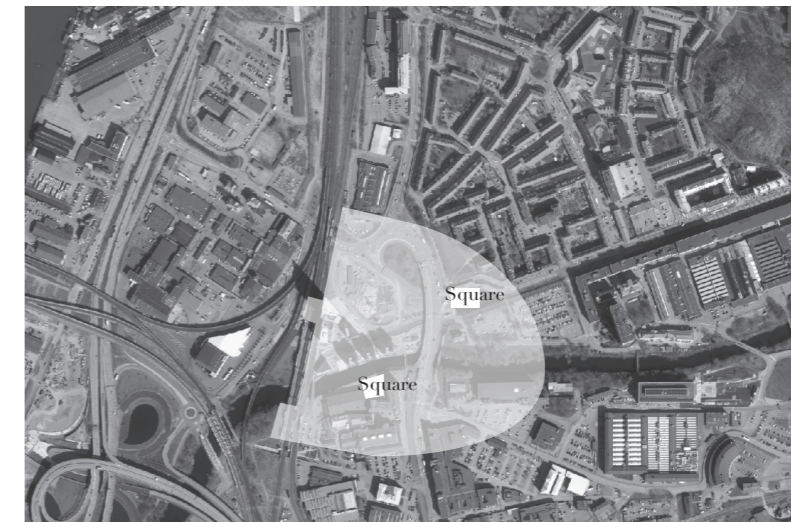

FIGURE 18 *New Lödöse.*

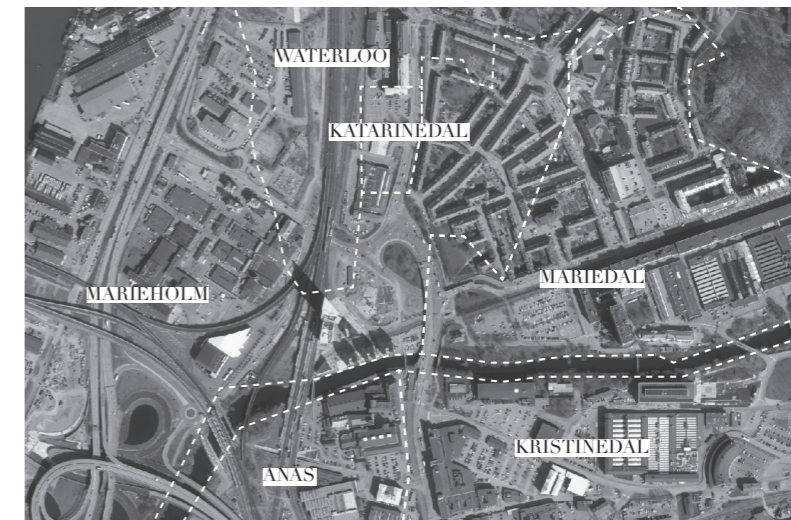

FIGURE 19 *The Landerier.*

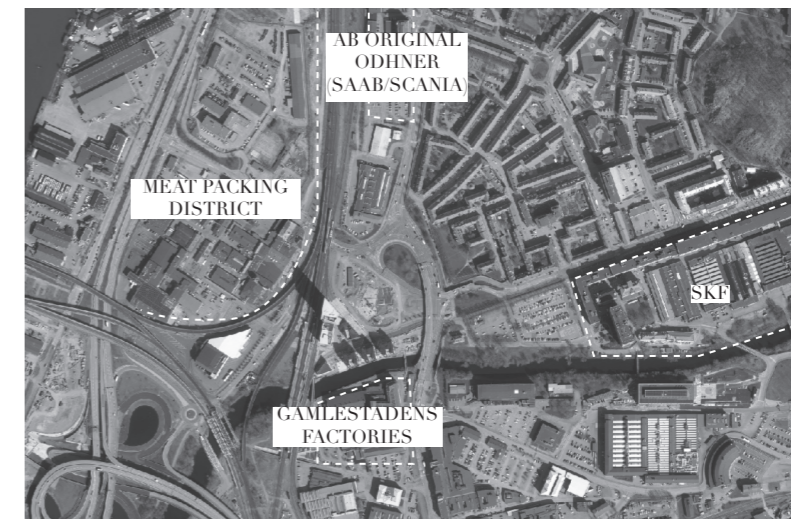

FIGURE 20 *The industries.*



FIGURE 21 Brandels cityplan, (Bjur & Engström, 2018, p 180)

With the industries followed a housing shortage and Hans Wilhelm Brandel made a city plan for Gamlestaden in the 1880's so that the workers and industries could build houses for the workers to live in. The city plan was based on a grid, where many of the streets that is still there today got their position. He also designed a broad street next to Säfveån called Säfve-strandgata. In 1910 the first parts of the city plan was built, among these houses where Kv. Aborren that was located on the plot. (Bjur & Engström, 2018)

SKF grew and the need for a new city plan for the area became evident.

Albert Lilienberg designed a new city plan more inspired by the garden city. Since parts of Brandels plan was already built Lilienberg couldn't change it too much. In the southern part Lilienberg pushed out and pulled in the blocks towards the streets to change the grid plan. Hornsgatan became an important axis, with Holländareplatsen in one end and Säfve Strandgata in the other. Lilienberg also banned buildings on the yard in his new plan.

In the northern part Lilienberg changed the old plan more, and directed the streets towards Gamlestadstorget. (Bjur & Engström, 2018)

In the 1970's parts of Gamlestaden was demolished to give room to traffic. Among these buildings where Kv. Aborren that was previously located on the site. (Det gamla Göteborg, 2019, 11 november)



FIGURE 22 Lilienbergs cityplan from 1913, (Bjur & Engström, 2018, p 181)

FUTURE



FIGURE 23 *The plans today*

Gamlestaden is undergoing a huge change at the moment, with a lot of projects planned and under construction. At the corner of Gamlestadsvägen and Artillerigatan, a park is planned. A new bridge will connect Hornsgatan with the other side of Sävån, making that street more important.

SKF

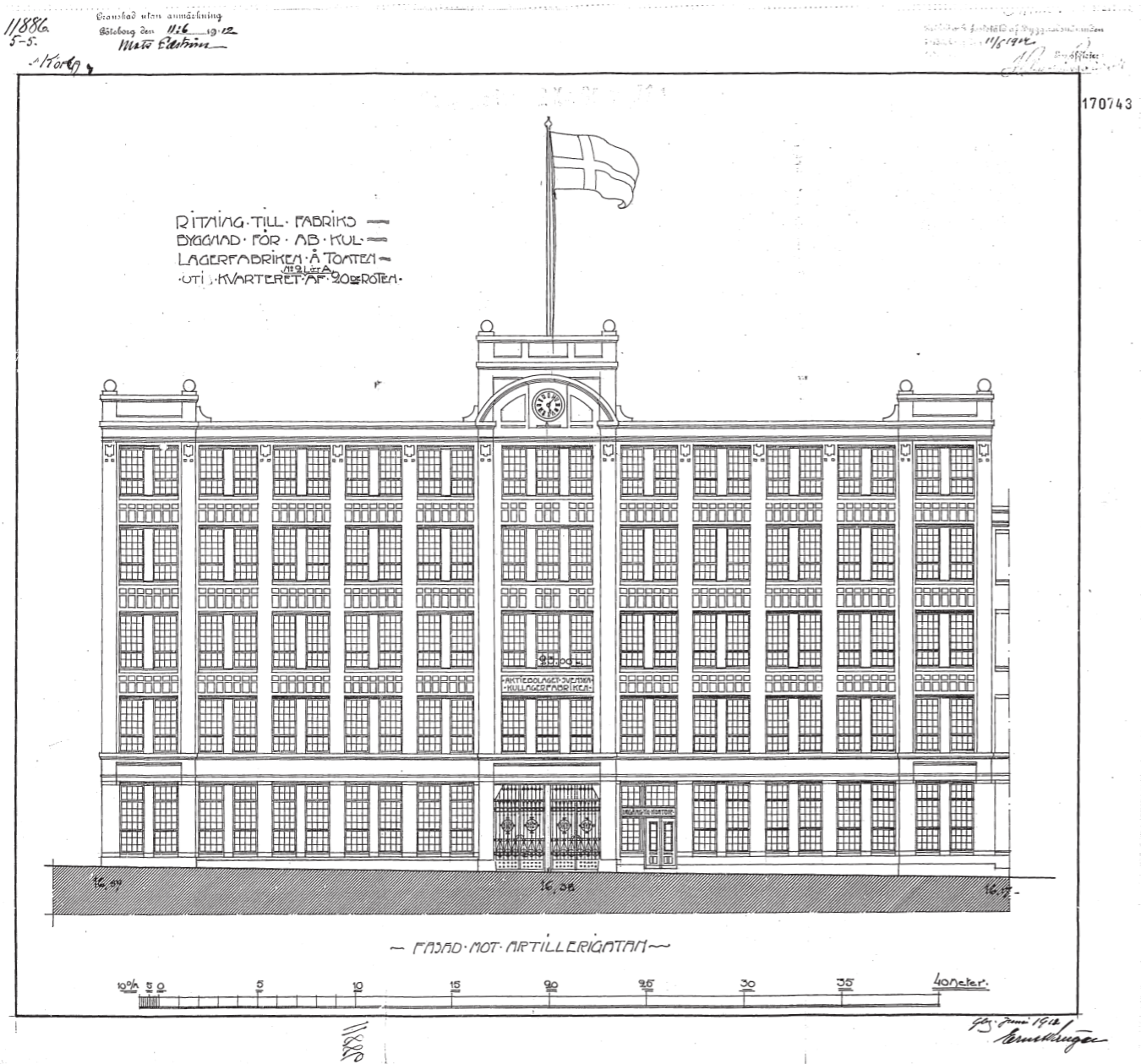

FIGURE 27 SKF facade, Scan from the city archive.

SKF's old factory buildings were designed by the architect Ernst Krüger and differed from other factories at the time, since all of the functions were placed in the same building. It had both changing rooms, offices and other functions near the factory. The first factory building does not exist anymore, but was built on the corner of the block, towards Söveån and Hornsgatan. (Brunnström, 1990). This is also where SKF's office building from the 1960's are now located. SKF recently moved out of the office building and the company is no longer present at the site.

The style of the SKF building was very much inspired by American architecture at the time. This can be seen in the rounded corner of the building and the large repeating windows. (Brunnström, 1990) Brick was the most commonly used material for factory buildings around 1900, and especially the red brick that is used in the SKF building. The main facade is very representative and richly decorated. This was typical for all kinds of architecture at the time and not only factory buildings. (Brunnström, 1990)

SKF



FIGURE 24 SKF, facade towards the site.
Own photograph.



FIGURE 26 SKF, the former A-factory. *Own photograph.*



FIGURE 25 SKF, old office building from the 60's.



FIGURE 27 SKF, rounded corner towards the site.
Own photograph.

05. PROCESS

VOLUME STUDIES

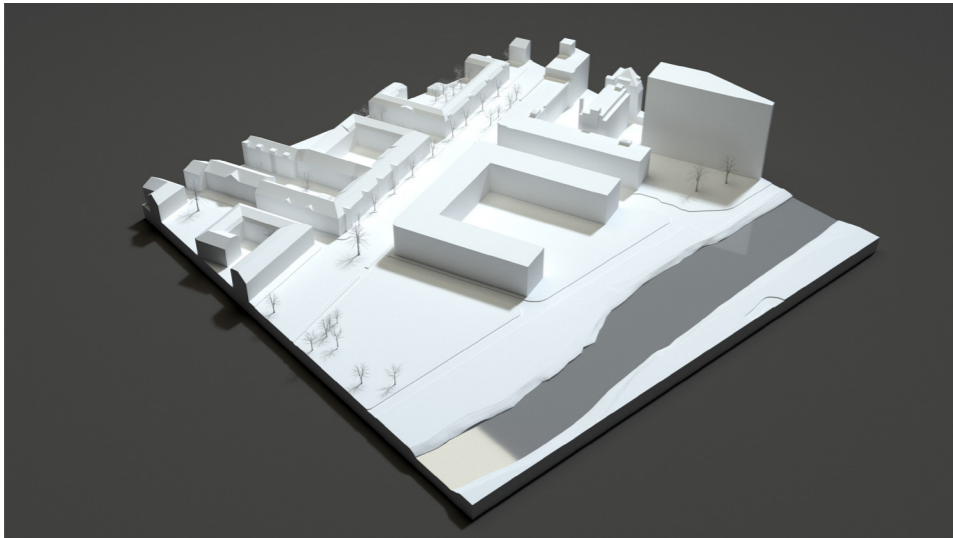

Open block, closed towards Artillerigatan, but open towards Sävån. The gables are too far from each other, the yard will probably be less used by the people living in the building.

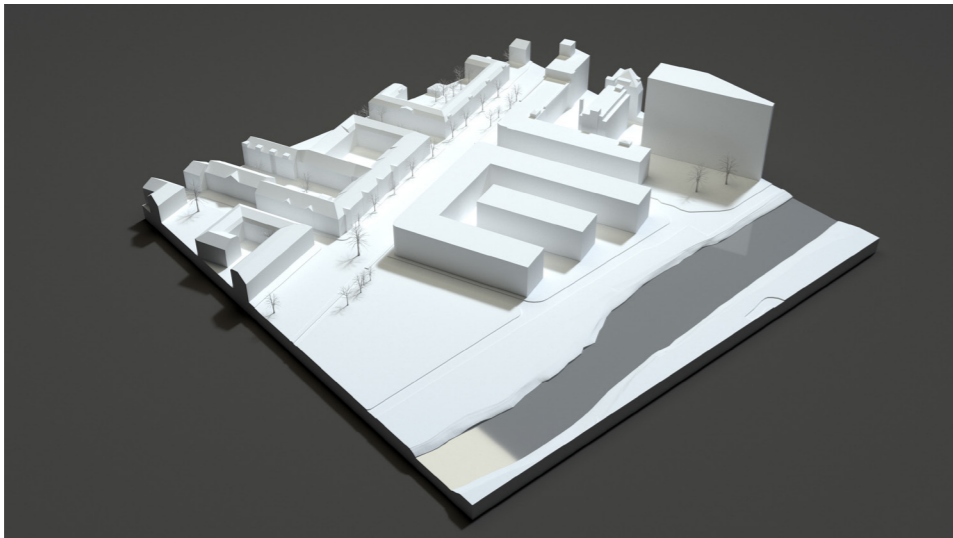

Added a volume in the middle to make the gables more balanced, almost no yard left. Will Säv Strandgata turn into a promenade? A lot of traffic on E20 that can be heard to this place. The buildings on the other side of Sävån not all that beautiful, would like to have control of the views.

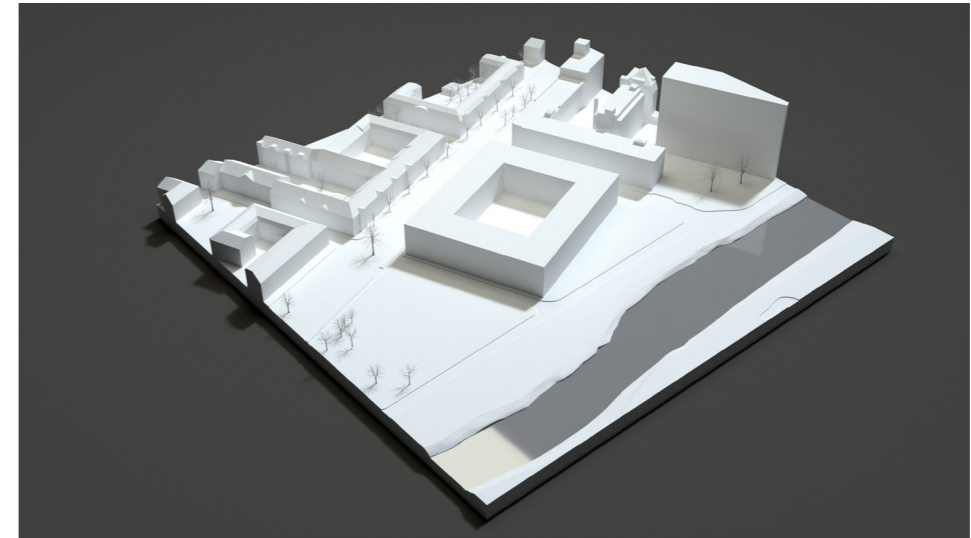

Closed block, big yard, more secluded from traffic, not following the street, feels wrong here, with the heritage from Lilienberg.

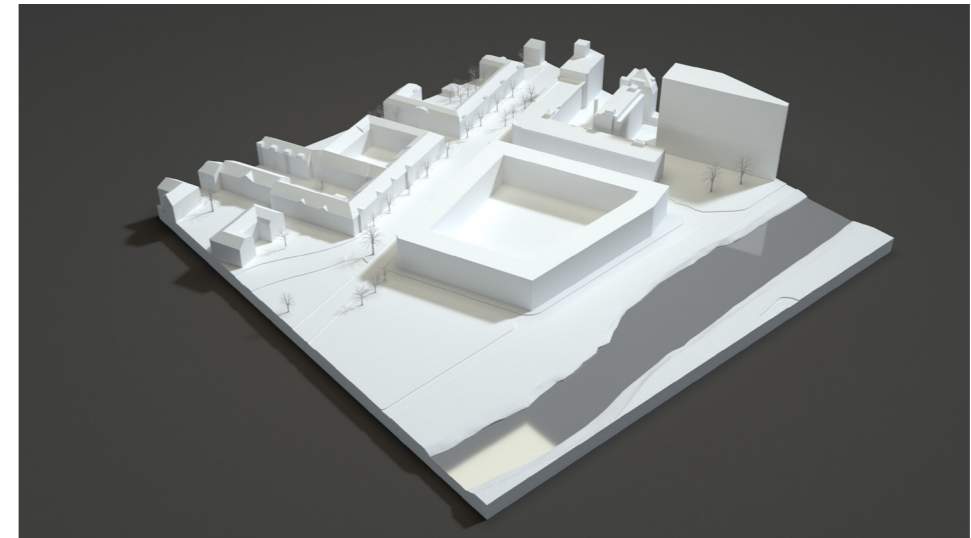

Closed block following the streets, too big of a yard? Hard to make smaller spaces in the yard, will be watched from all windows in the house when you use the yard.

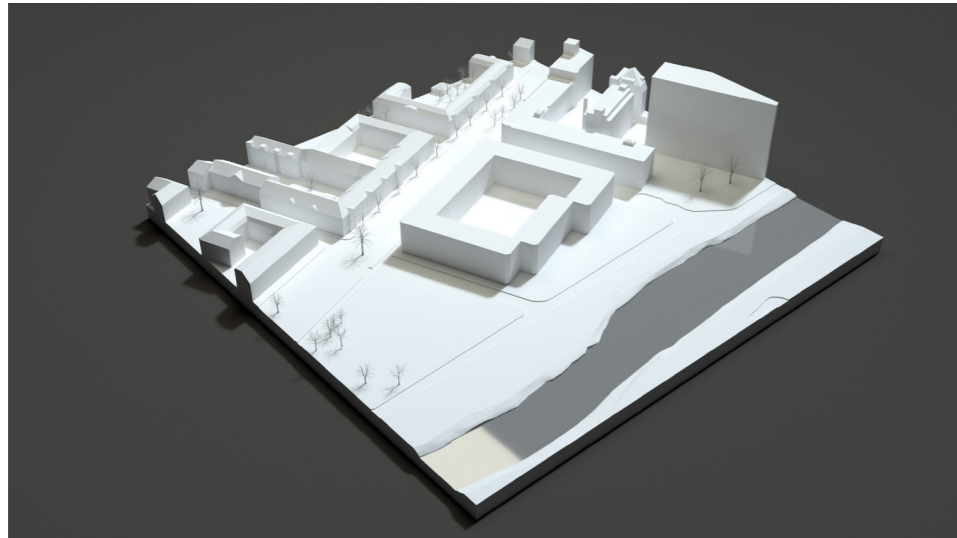

Pulling the volume back to make it smaller, feels like a mashed up compromise. Leaving a lot of space towards Sävveån, that will already be some kind of park.

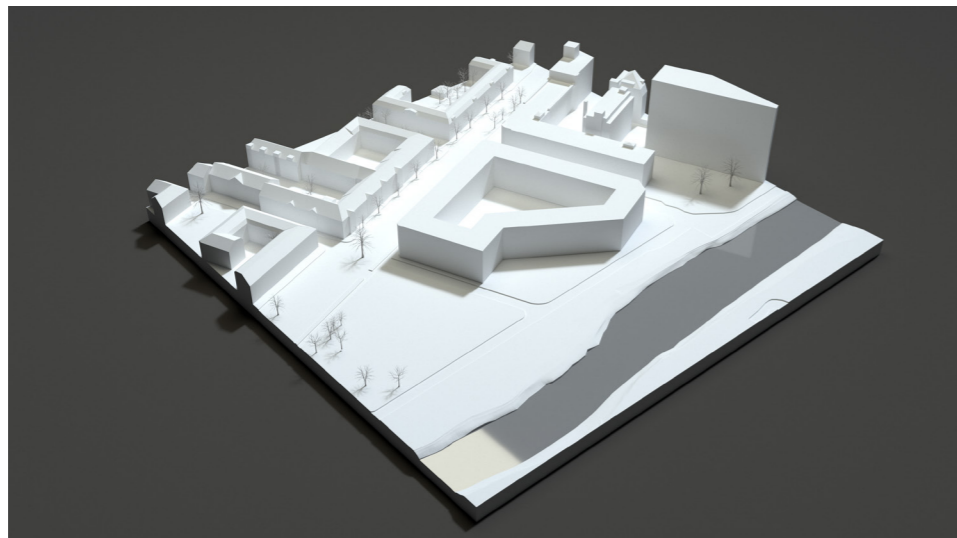

Closed block that leaves room for a small place in the southeast corner, good for outside seating for restaurants, is the place to big?

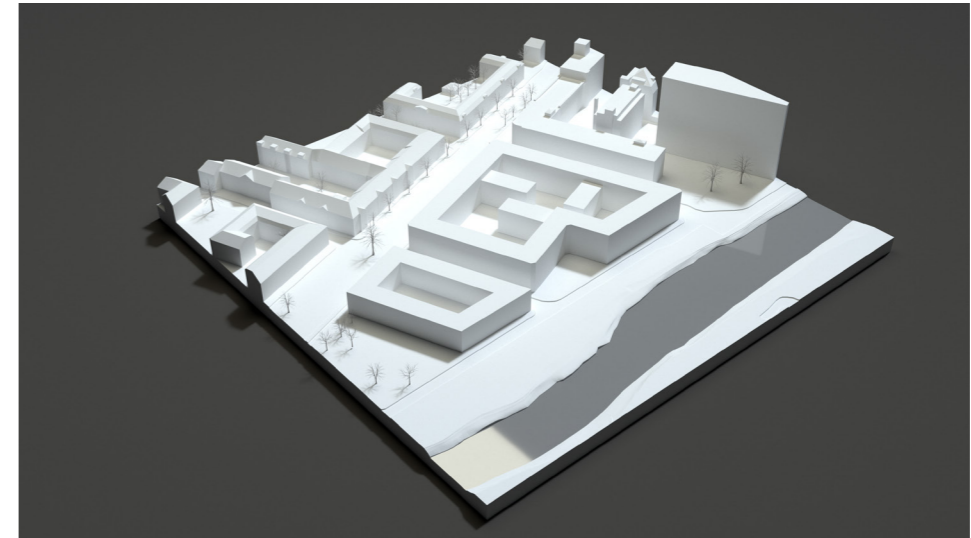

Smaller space in the southeast corner, another volume added framing the space and the new part of Banérskatan. Volumes added to the yard, to break the yard up in smaller spaces, still a big yard but smaller spaces on the yard.

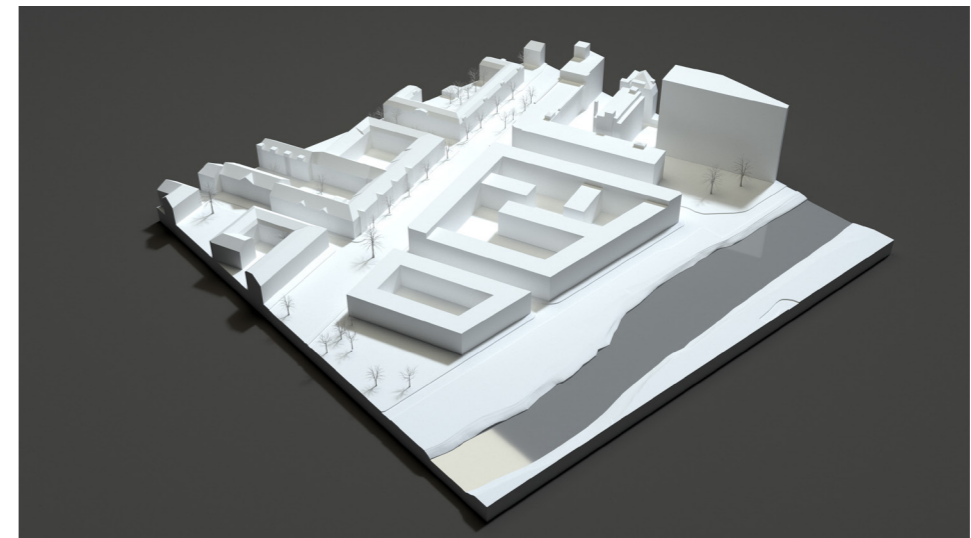

No space in the southeast corner, will there be enough people for restaurants on that smaller street? The southeast part is lower to let in more light on the yard, Roof terrace?

SUN STUDIES

Vernal Equinox

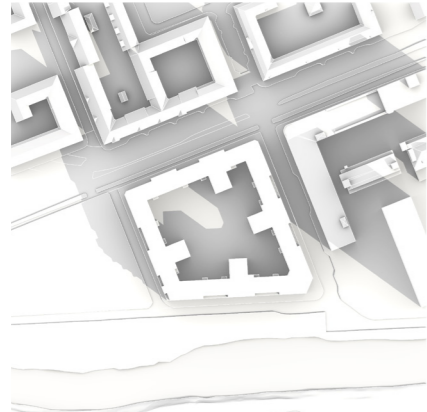

9:00

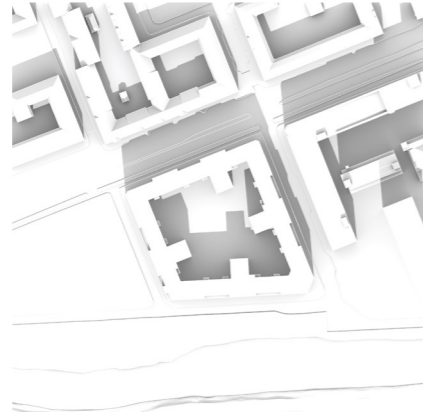

12:00

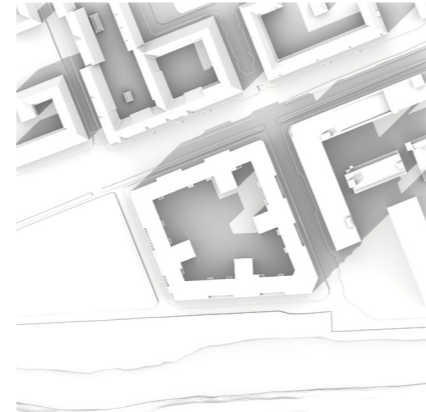

15:00

Summer Solstice

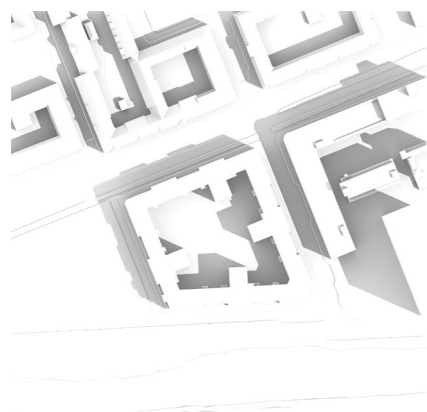

9:00



12:00



15:00

Winter Solstice



9:00



12:00



15:00

PLAN STUDIES

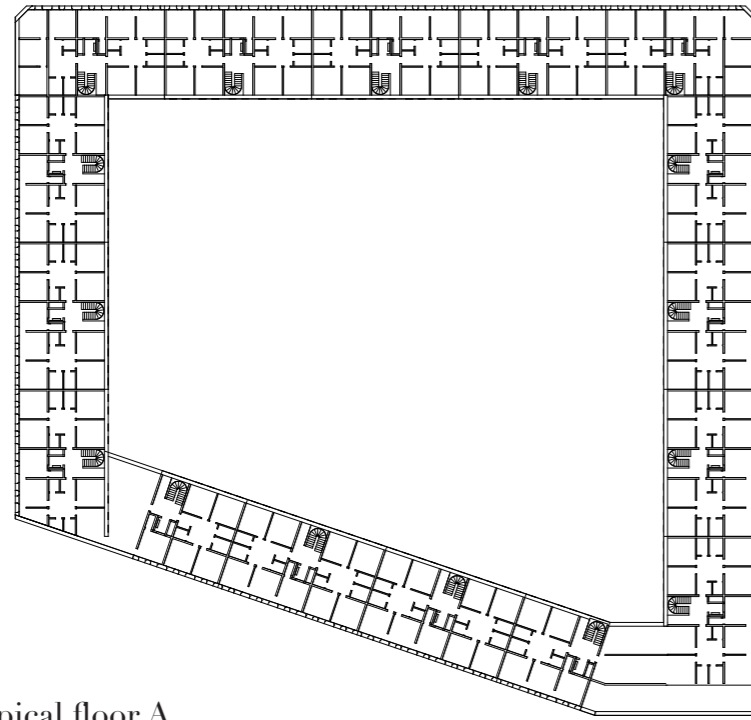

Typical floor A
Scale 1:1000

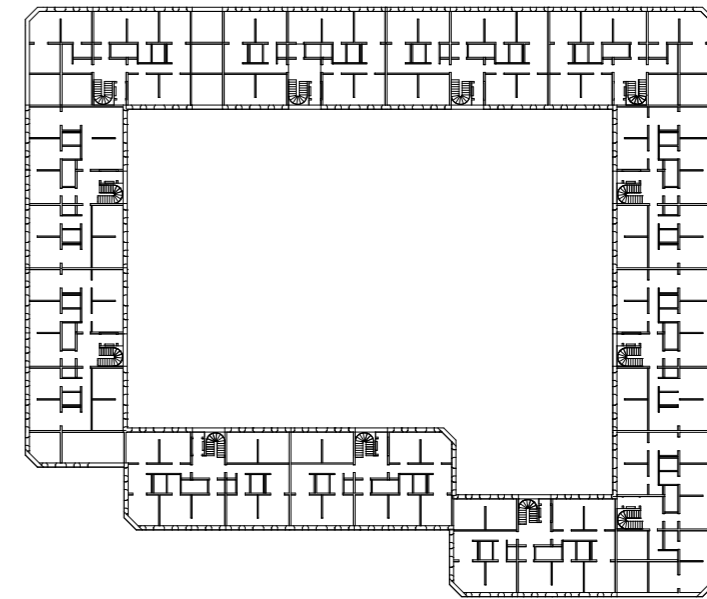

Typical floor B
Scale 1:1000

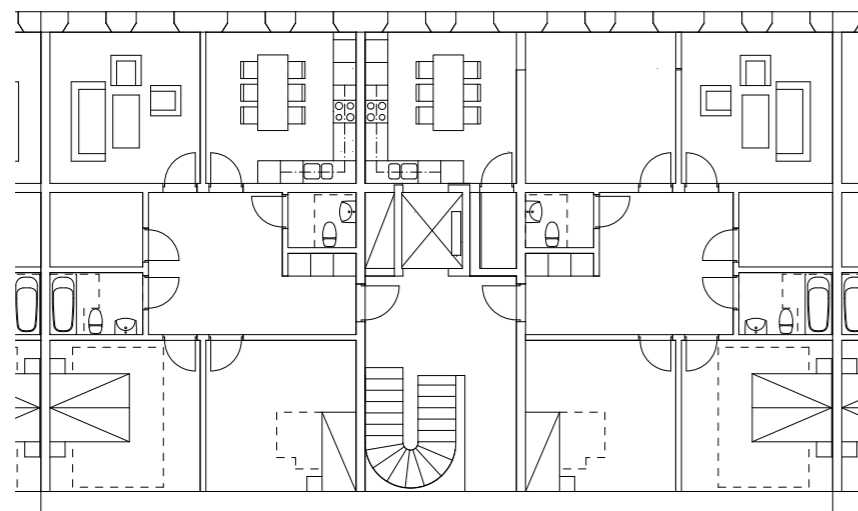

Apartment plan A
Scale 1:200

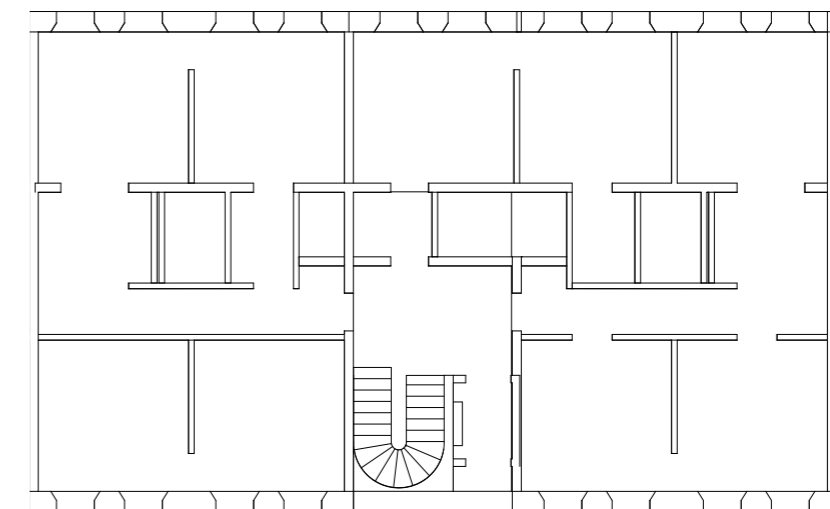

Apartment plan B
Scale 1:200

Plan A

- + General size and shape of the rooms, installations collected in the core, axes along the facade, light stairwell.
- Big apartments, big hallway in the middle of the apartment that is hard to use, only 2 apartments per stairwell

Plan B

- + General size and shape of the rooms, installations collected in the core, 3 apartments per stairwell instead of 2, light stairwell
- Kitchen in the core might not be that nice, a lot of corridors in the core. The one bedroom apartment is not that good.

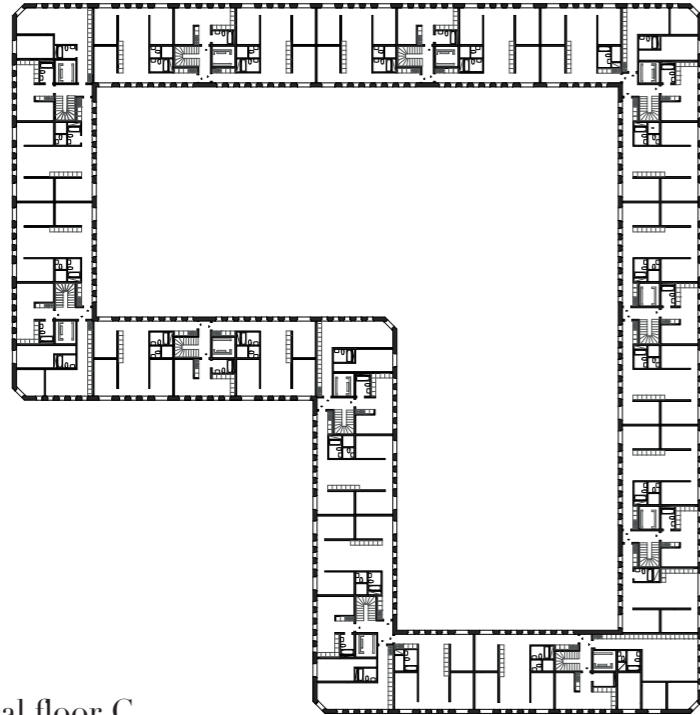

Typical floor C
Scale 1:1000

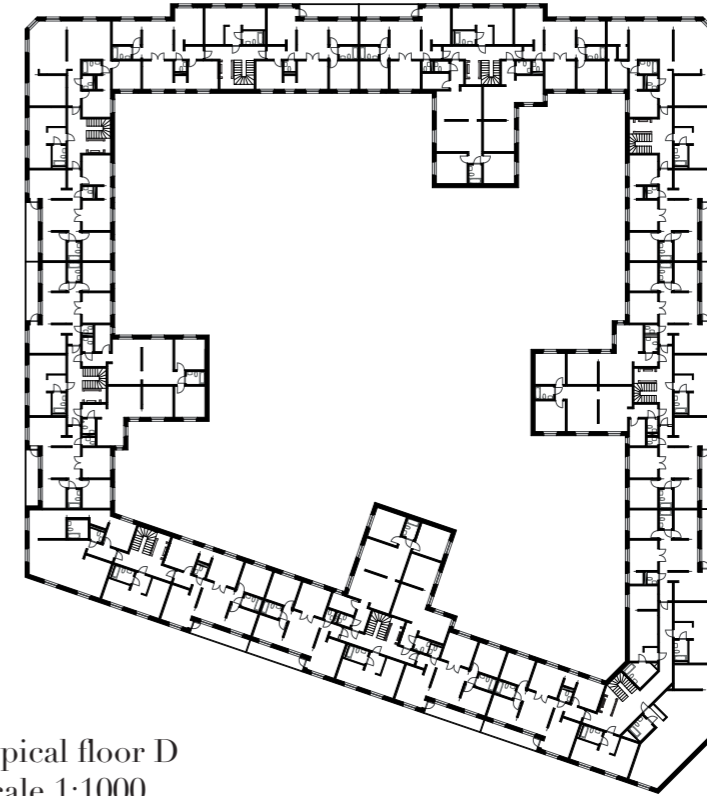

Typical floor D
Scale 1:1000

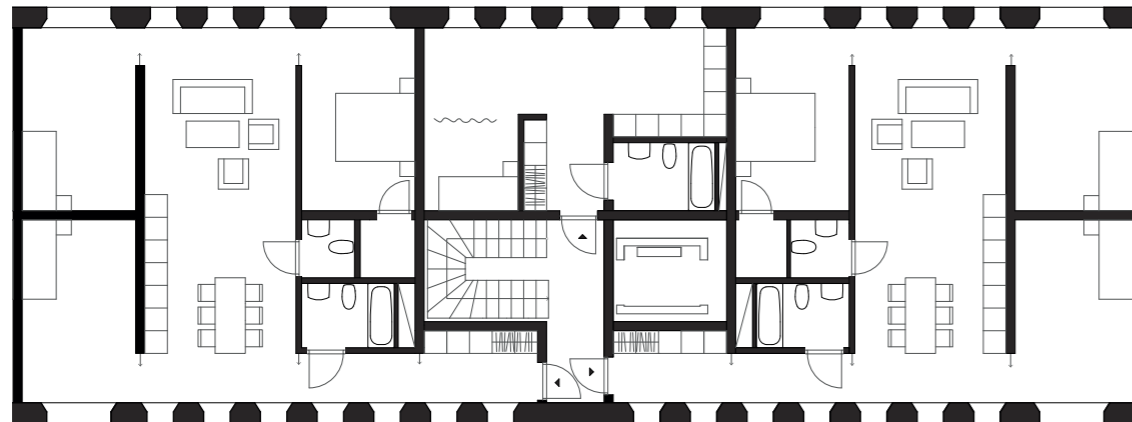

Apartment plan C
Scale 1:200

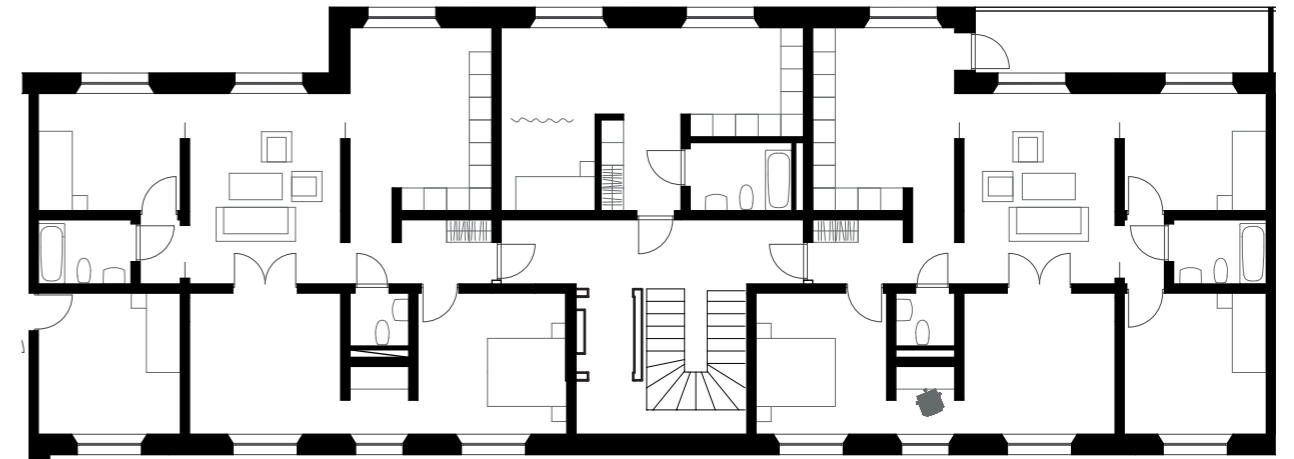

Apartment plan D
Scale 1:200

Plan C

+ Axes along the facade, nice with a light entry, sequence into the apartment, light stairwell without it being at the facade, 3 apartments per stairwell instead of 2.

- The apartments are still a bit too big (105 squaremeters for the 4 room apartment.) The rooms are a bit too deep. The wall making the stairwell light will not be enough to get the effect of reflections from the sun that I want.

Plan D

+ Axes along the facade, light stairwell, 3 apartments per stairwell. A variation towards the street and in the enfilade.

- Long balconies along the facade, breaks up the facade and doesn't look good.

ELEVATION STUDIES

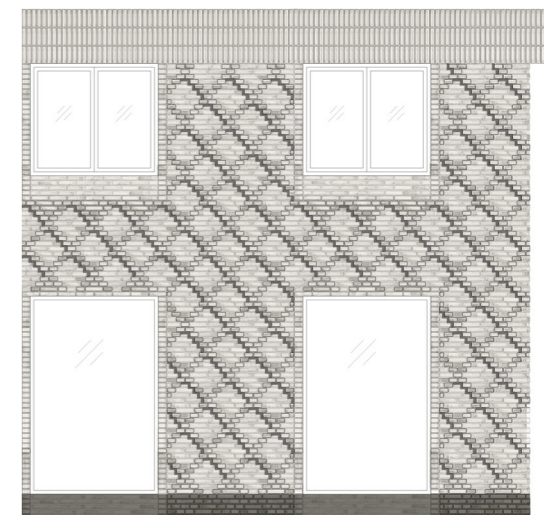
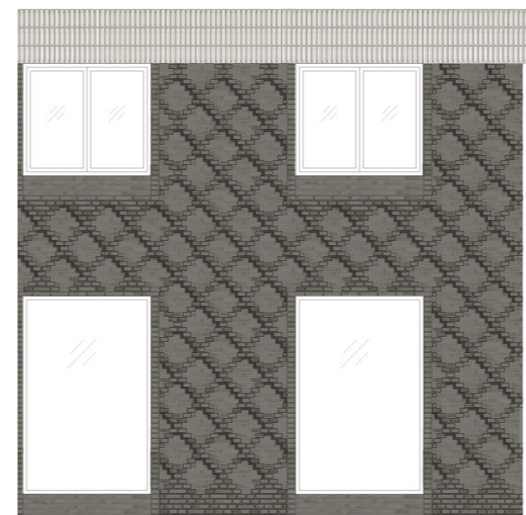
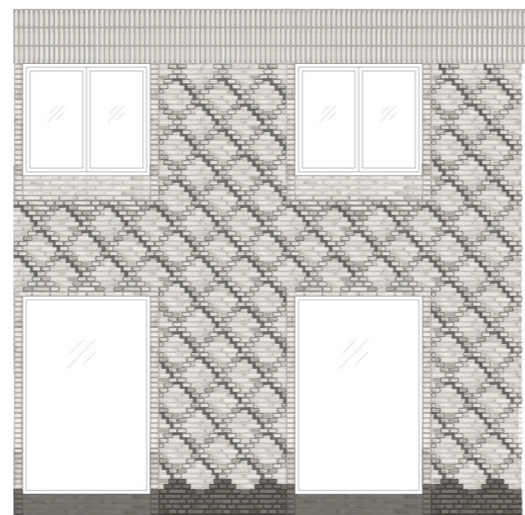
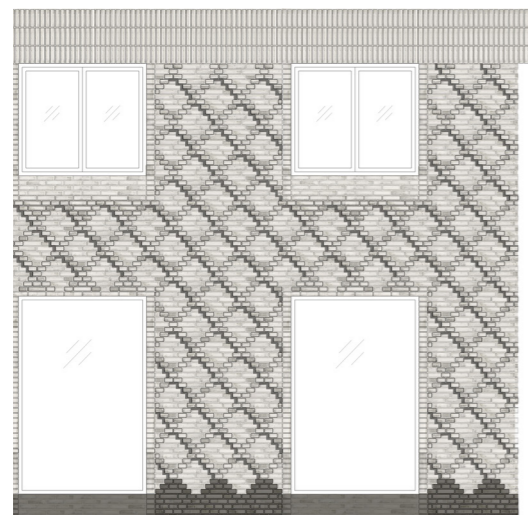

Some iterations of elevations and coloring of the socle, before the final design solution. The module of danish brick was used while designing the facades.

DETAIL STUDIES

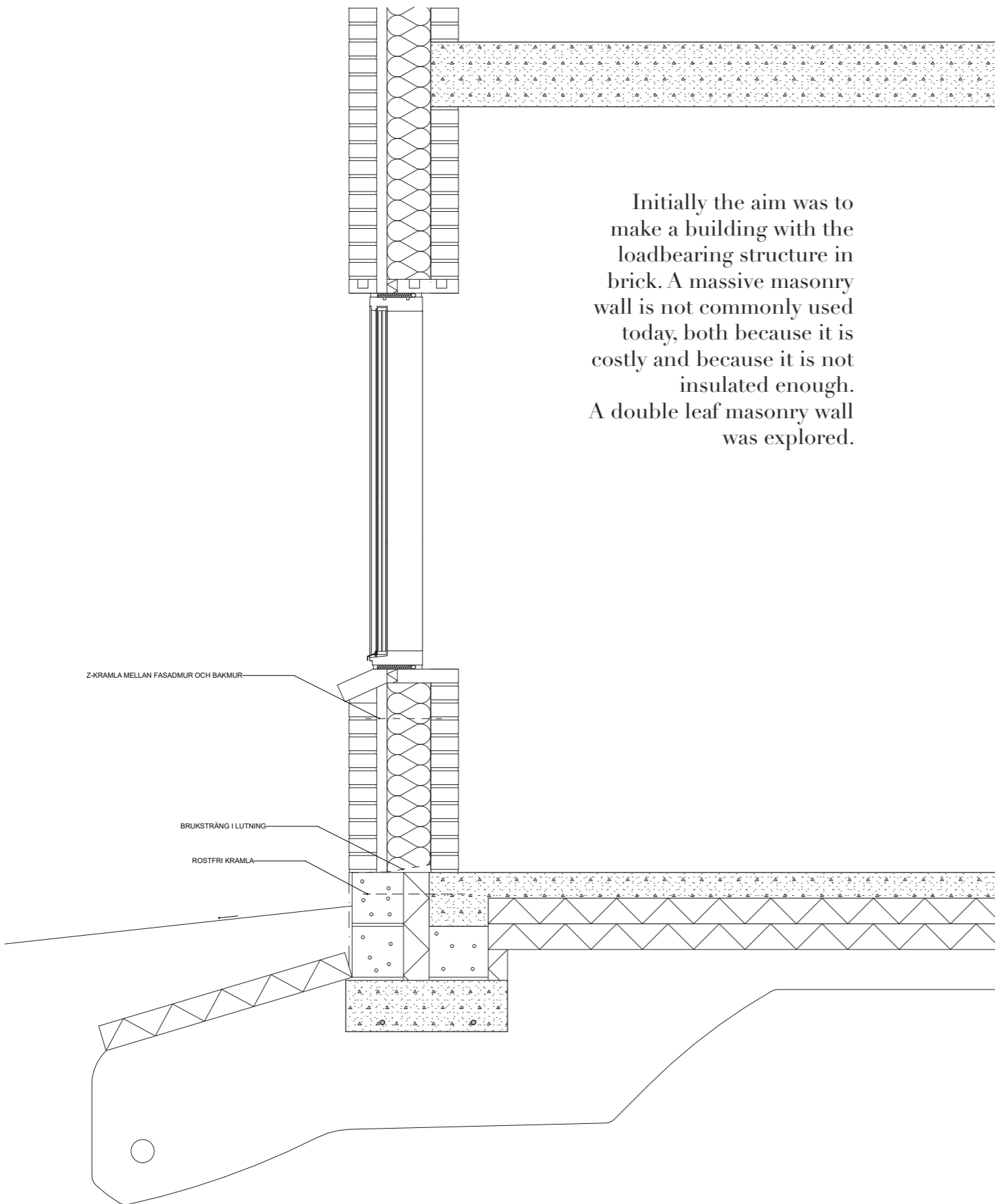

Initially the aim was to make a building with the loadbearing structure in brick. A massive masonry wall is not commonly used today, both because it is costly and because it is not insulated enough. A double leaf masonry wall was explored.

Another brick in the wall
70

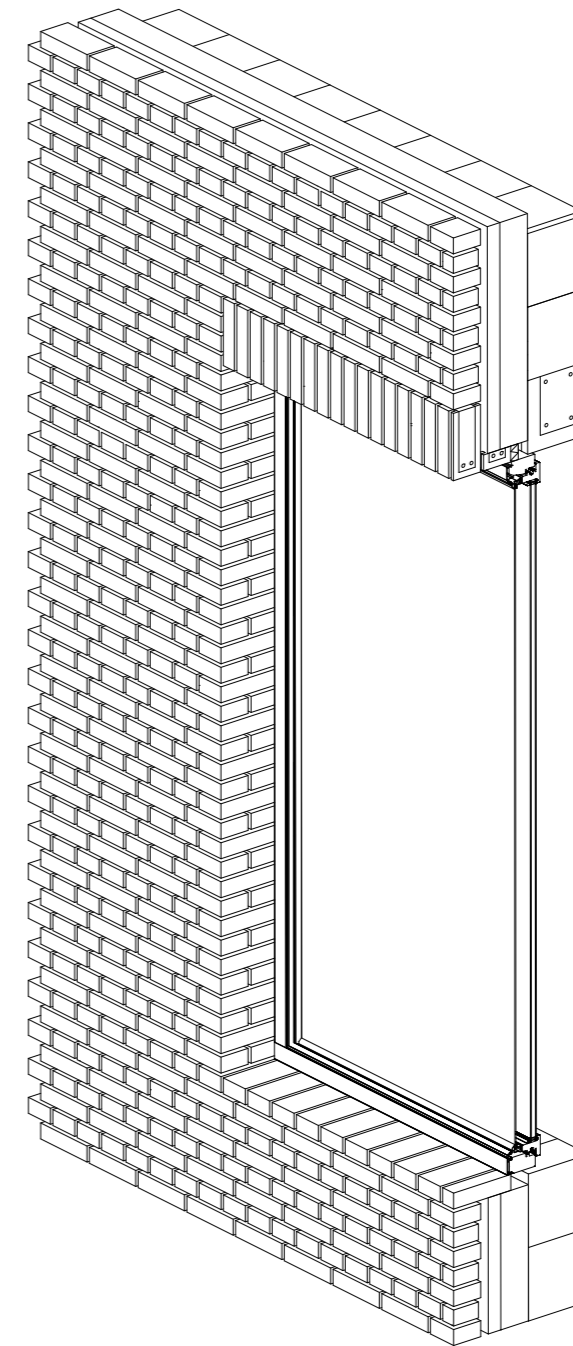

A loadbearing structure with two 1/2 brick walls, would probably not be sufficient for the residential building. The residents should also have the opportunity to influence their home, which makes plaster a better choice on the interior side of the walls than exposed brick. Here the loadbearing structure is masonry-blocks, that is cladded in brick, the brick is therefor more of a superficial layer, even though it looks as if the wall is made entirely out of brick.

Embla Jensen, 2021
71

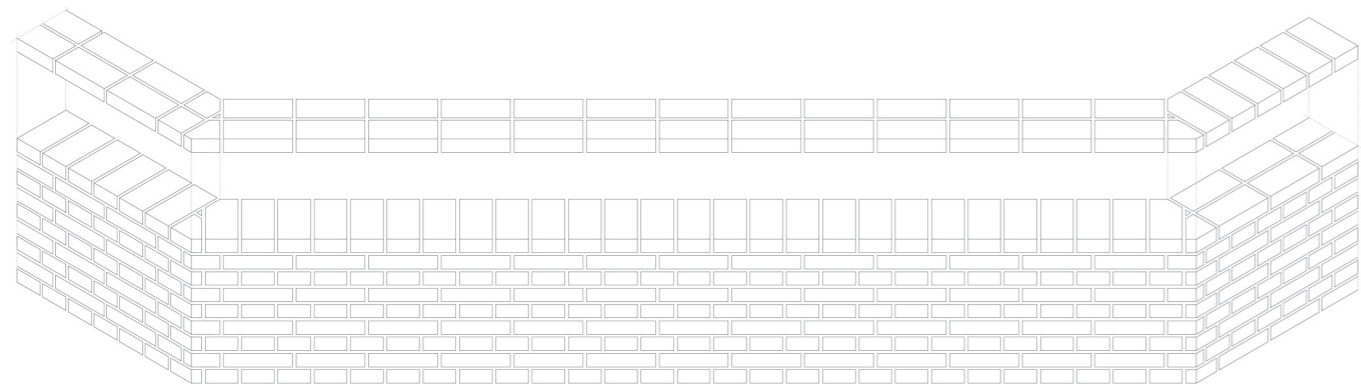
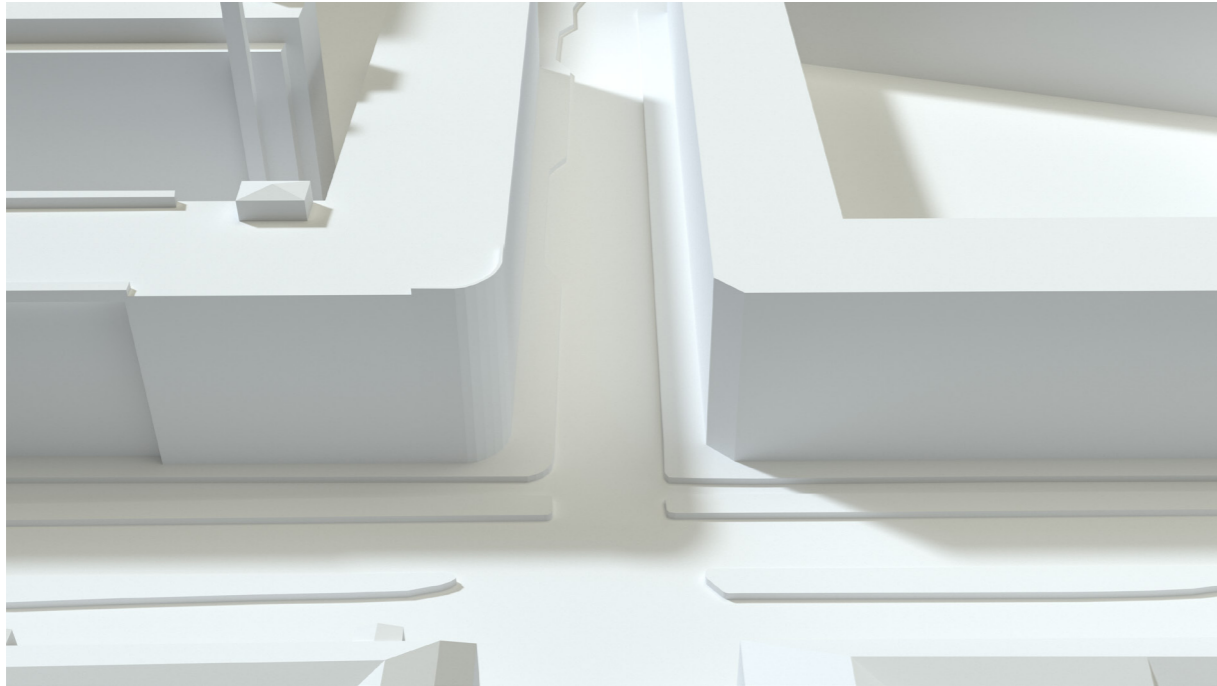

The corner of the SKF A-factory is rounded. This is mirrored in the new volume, but made as a 45 degree angle instead, so called "stumphörn" which is common in brick architecture.

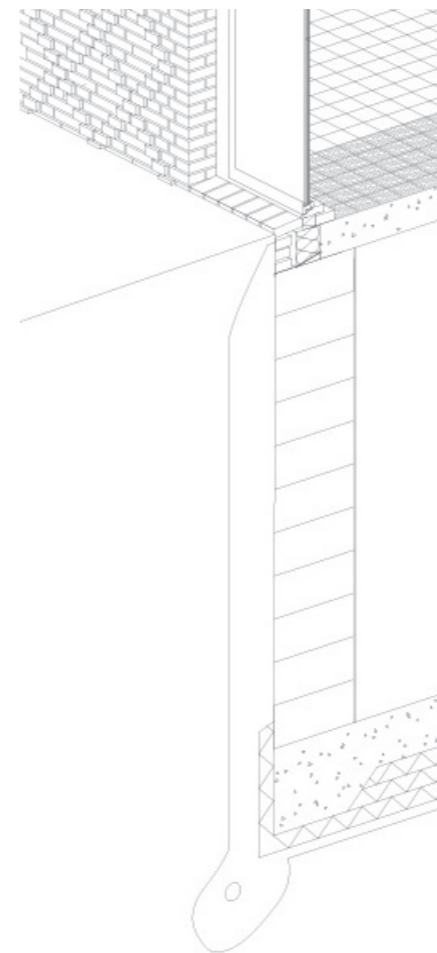
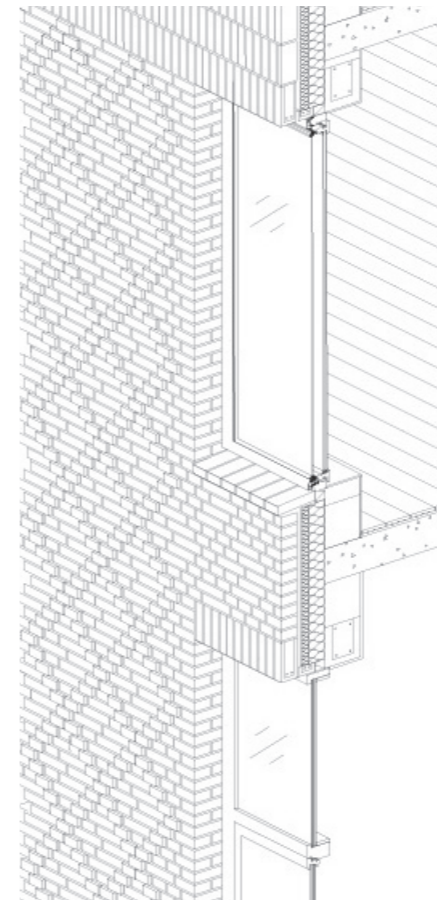

Iterations on a relief in the socle and brick that continues down into the ground.

MATERIALS

The colour of the brick chosen for the project was dependent on two things: firstly the clay needed for the specific colour of brick. I wanted it to be the local clay in Gothenburg, which has a high percentage of lime. And secondly I wanted to reference the old SKF-factory, where the old factory buildings are red and the offices are yellow. I wanted this new typologie to have a third colour.



D91 Petersen



D92 Petersen

07. CONCLUSIONS

REFLECTIONS

The initial purpose for this thesis was to investigate a way of designing buildings for the long term. And a great deal of time was spent reading books that reflected on different aspects of this; Durability, flexibility and timelessness.

Even though care has been given to different kinds of these aspects during the thesis work, the main focus of investigation has been on brick and masonry construction. Using the rules of masonry construction and investigating the materiality of brick has been exciting, and much has been learned while doing this.

The decision to design a residential building, and in this case a large residential block, came about because of the dwelling as a constant need throughout human history. The choice of housing was a way of not making a too specific building, which would make it perfect for the program, but not for much else when the world changes. But instead it turned out, not surprisingly looking back, that the function of a dwelling is something that everyone can relate to, and therefore have very specific thoughts about what it should be.

I would say that the most challenging part was zooming in and out between this large block and the very small block, the brick.

Brick is, in my opinion, a material for the long term, and it has been a pleasure working with, and getting to know this material. And even though this thesis ended up focusing on this specific aspect of longevity. The question of how to build buildings that last is something that I will continue to think about for the rest of my life.

REFERENCES

- Bjur, H., & Engström, K. (2018). *Lilienbergs stad : Göteborg 1900-1930* (1st ed). Balkong.
- Brand, S. (1995). *How buildings learn : what happens after they're built*. Phoenix.
- Brunnström, L. (1990). *Den rationella fabriken : om funktionalismens rötter*. Dokuma, Umeå.
- Deplazes, A. (2018) *Constructing architecture*. (4th ed). Birkhäuser, Basel.
- Det gamla Göteborg. (2019, 28 november). *Gamlestaden*. <http://gamlagoteborg.se/2019/11/28/gamlestaden/>, retrieved 14 mars, 2021
- Fossilfritt Sverige. (2018). *Färdplan för fossilfri konkurrenskraft, bygg- och anläggningssektorn*. http://fossilfritt-sverige.se/wp-content/uploads/2018/01/ffs_bygg_anlggningssektorn181017.pdf, retrieved 7 november 2020
- Gustavsson, T. (2008). *Moderna tegeldetaljer : med teglets materialitet som utgångspunkt*. Arkitekternas forum för forskning och utveckling, Arkus.
- Hall, W., & Cruickshank, D. (2015). *Brick*. Phaidon.
- Naturvårdsverket. (2020, 10 november). *Konsumtionsbaserade utsläpp av växthusgaser*. <https://www.naturvardsverket.se/Sa-mar-miljon/Klimat-och-luft/Klimat/Tre-satt-att-berakna-klimatpaverkande-utslapp/Konsumtionsbaserade-utslapp-av-vaxthusgaser>, retrieved 5 december 2020
- Kummer, N., & Robinson, M. (2007). *Basics masonry construction*. Birkhauser-Publishers for Architecture.
- Mostafavi, M., & Leatherbarrow, D. (1993). *On weathering : life of buildings in time*. MIT Press.
- Nylander, O (1998) *Bostaden som arkitektur*. Form och teknik Chalmers.
- Tegelmäster. (n.d.). *Murverksmått*. <https://tegelmaster.se/teknik/murverksanvisning/murverksmatt>, retrieved 12 april 2021
- Vandersanden. (n.d.). *What determines the colour of a brick?*. <https://www.vandersanden.com/en-uk/what-determines-colour-brick>, retrieved 5 may 2021
- Murerbogen*. (1995). Erhvervsskolernes Forlag.

06. APPENDIX DESIGN PROPOSAL

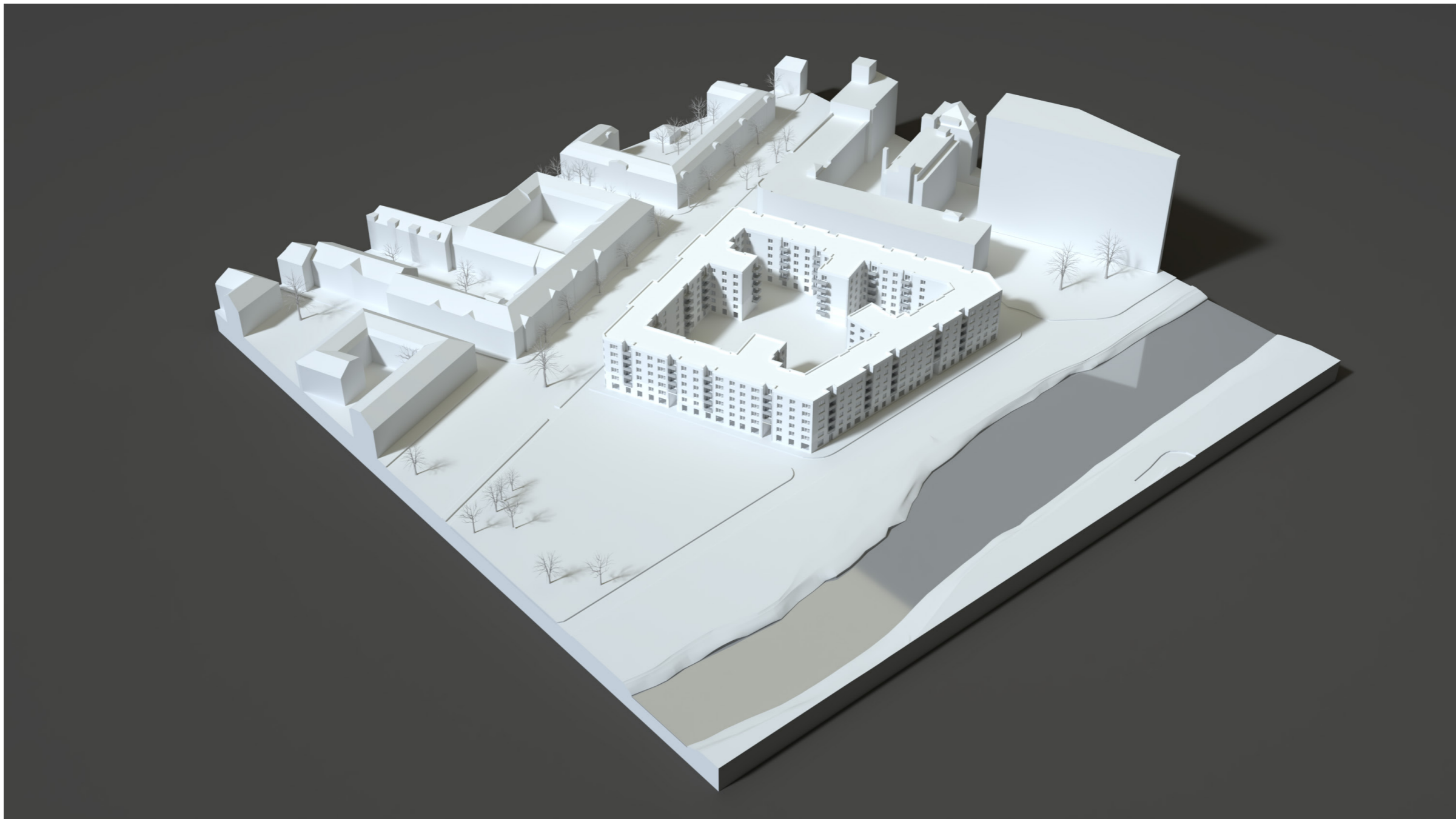

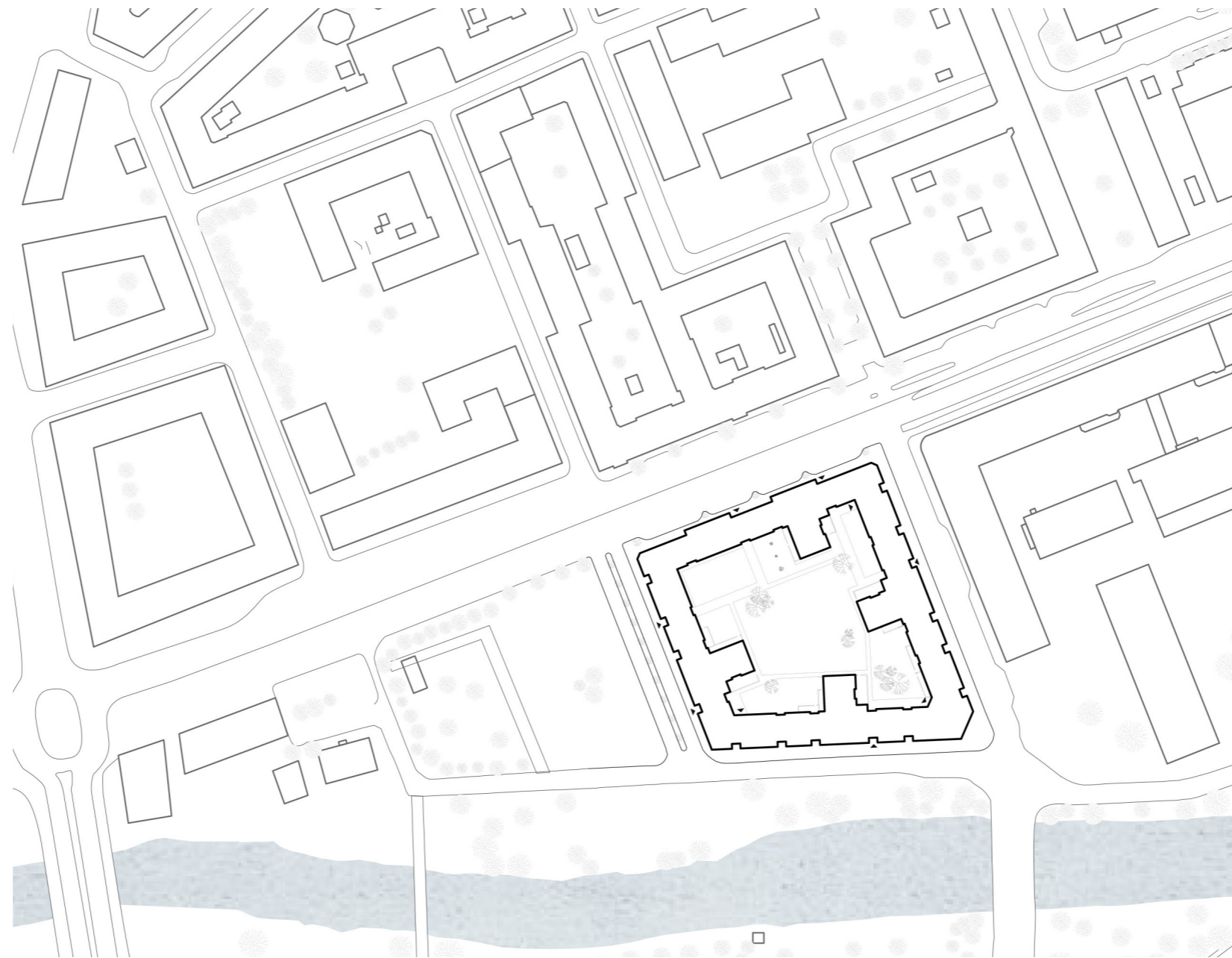

Siteplan
Scale 1:2000

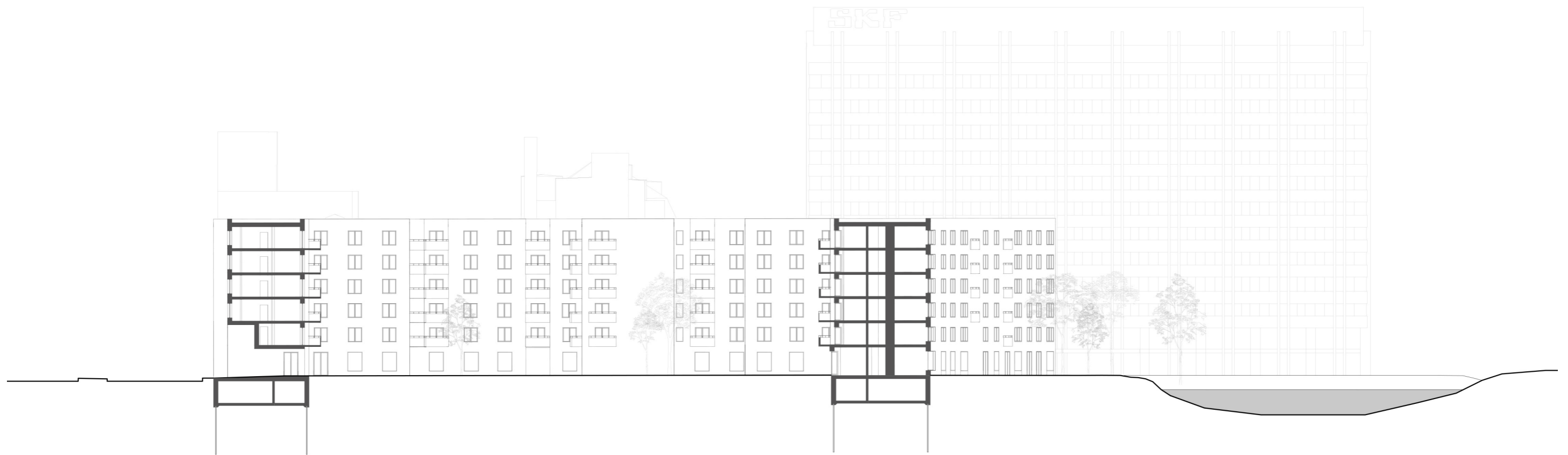

Section of the site, B-B
Scale 1:500



View of the gate into the yard

- 1. Bike storage
- 2. Trash room
- 3. Trolley storage
- 4. Rentable space

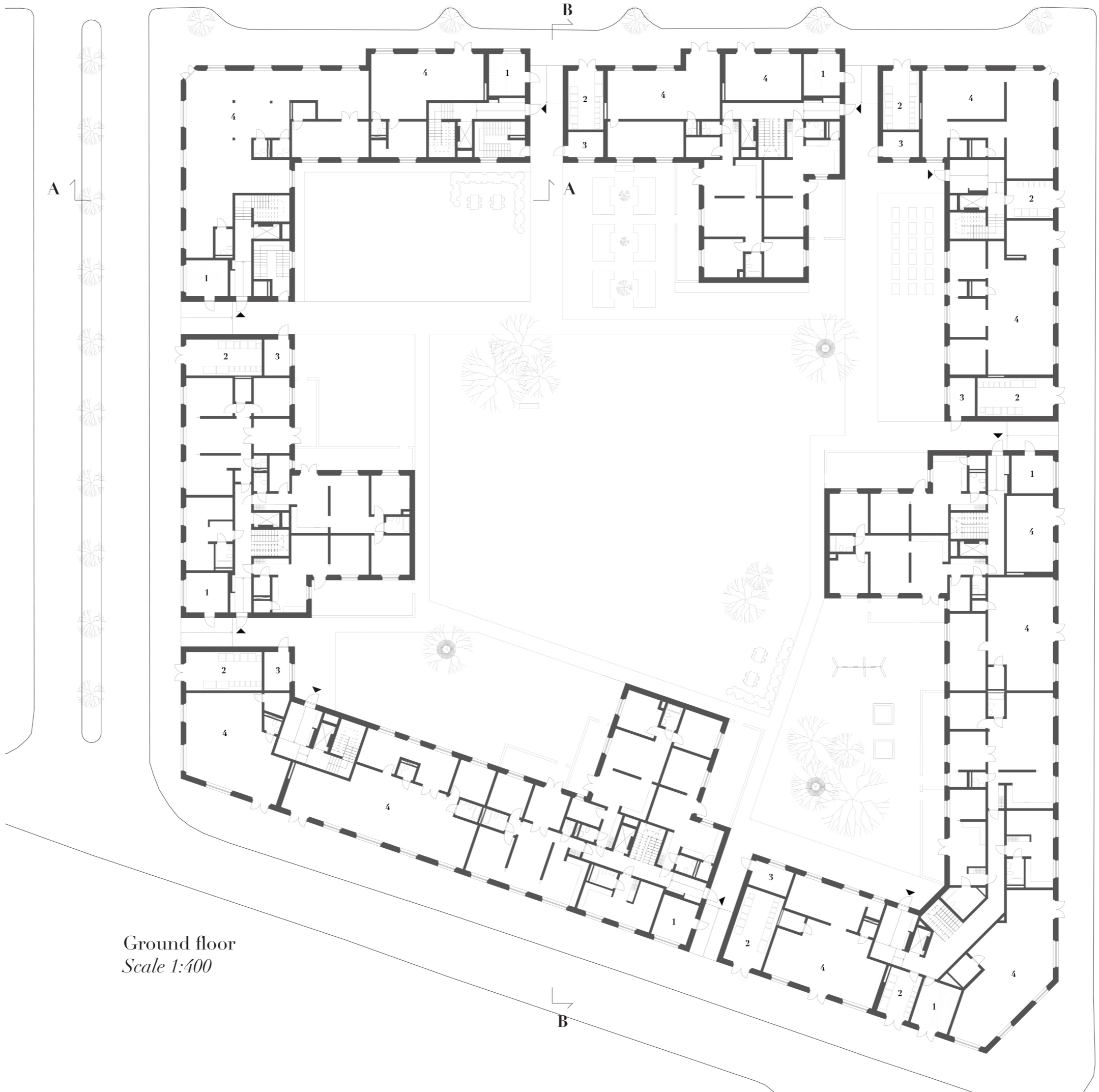

Ground floor
Scale 1:400

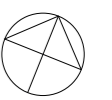



View of entry

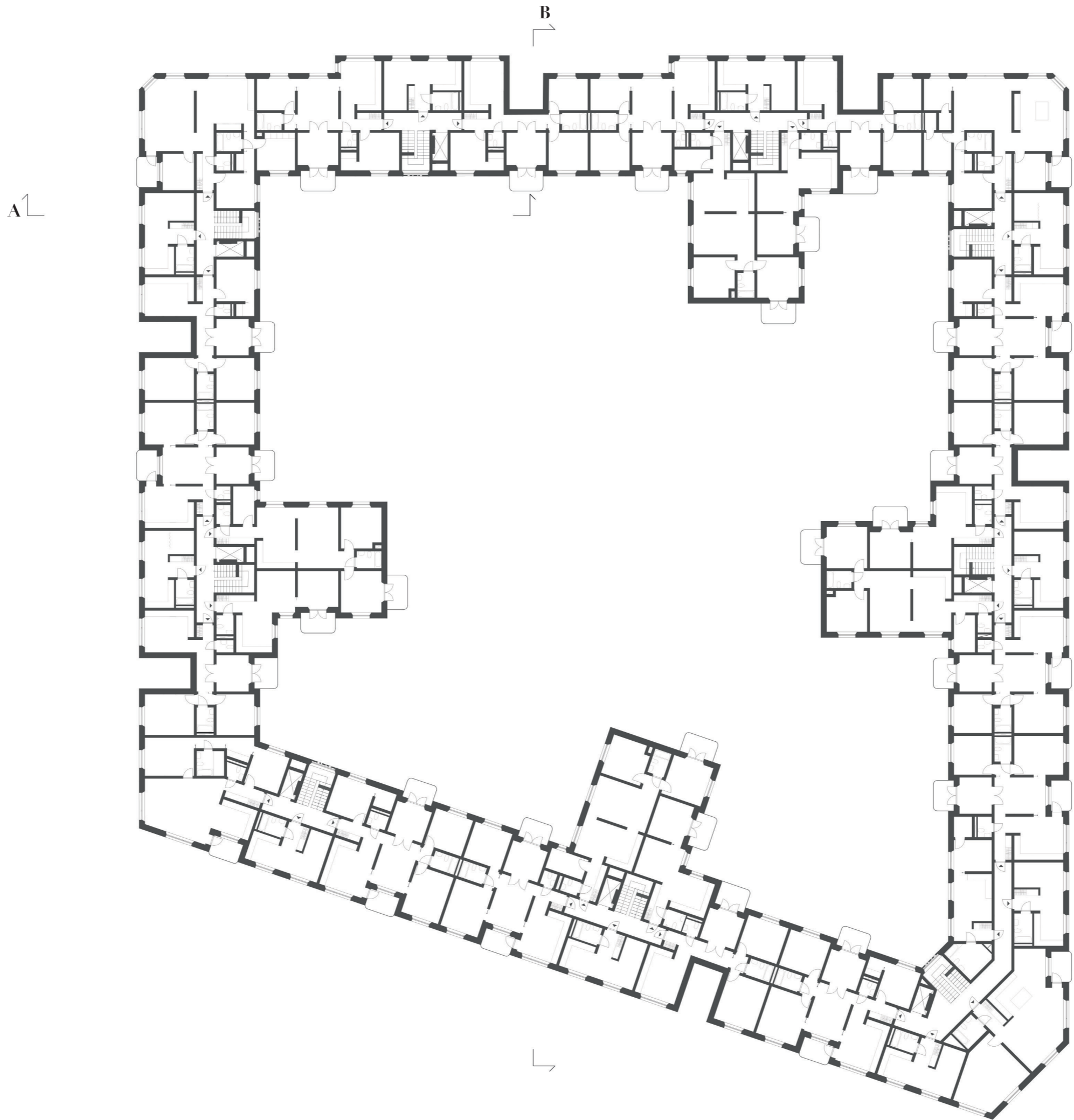

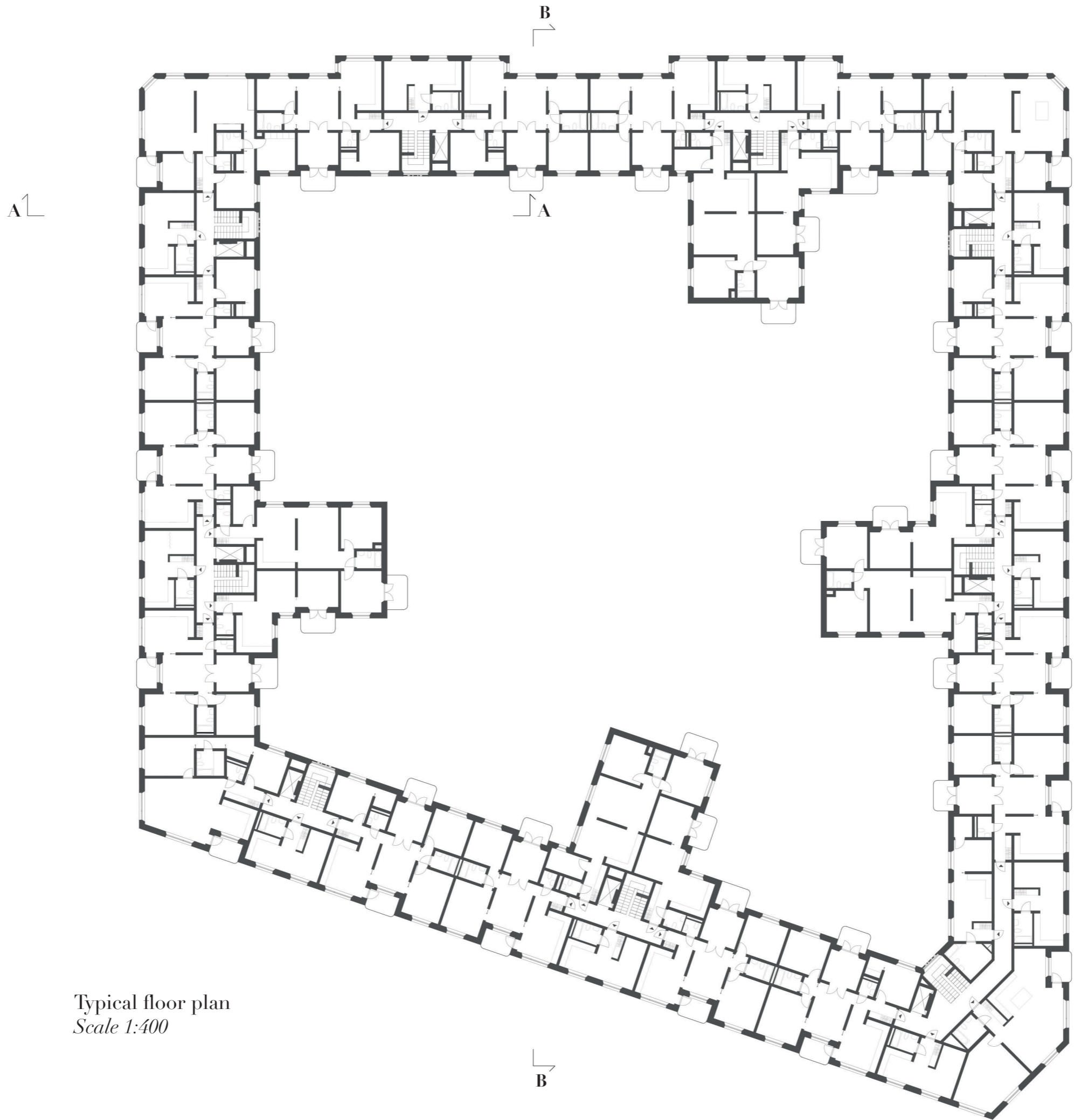

Typical floor plan
Scale 1:400



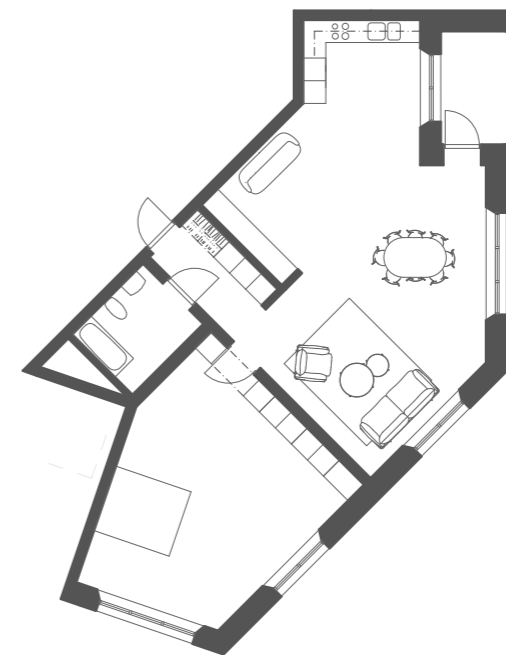
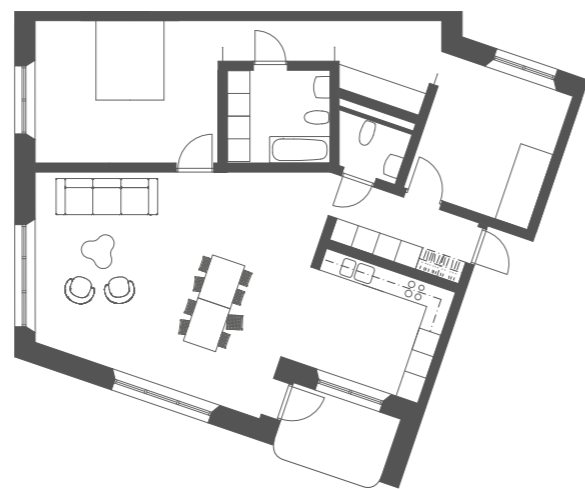
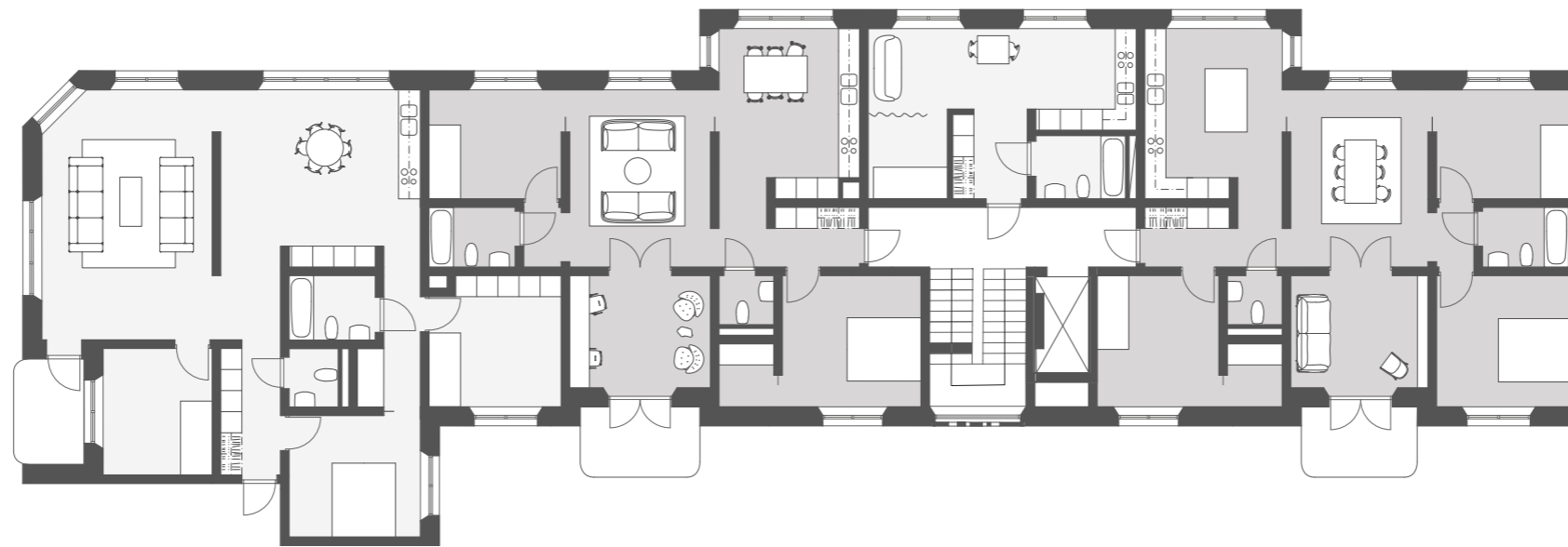

Apartment plans
Scale 1:200



View of enfilade in apartment

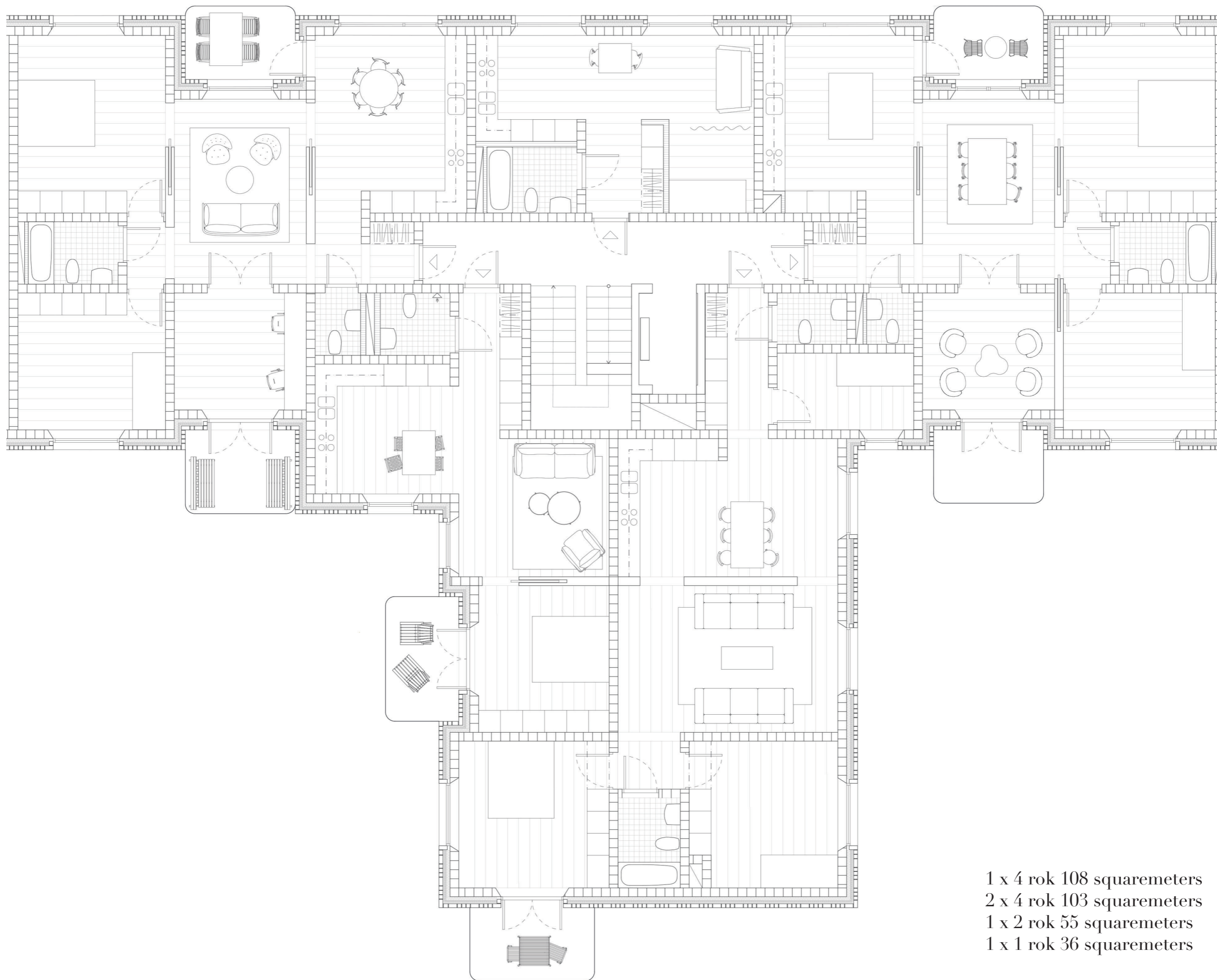

1 x 4 rok 108 squaremeters
2 x 4 rok 103 squaremeters
1 x 2 rok 55 squaremeters
1 x 1 rok 36 squaremeters



View of apartment with balconies on both sides

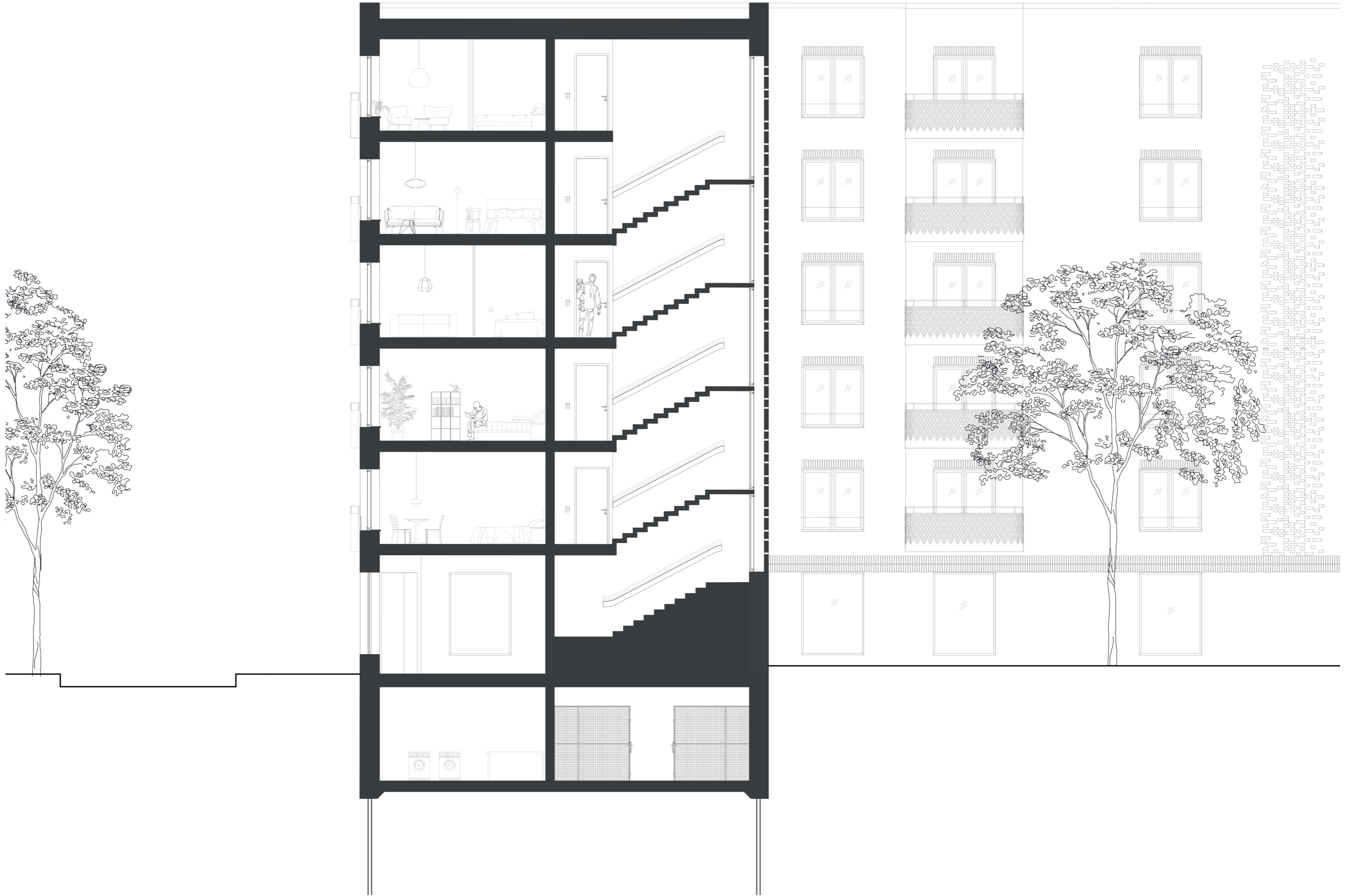



Elevation towards Hornsgatan,
Scale 1:400



Elevation towards Artillerigatan
Scale 1:400



Elevation towards Kullagergatan,
Scale 1:400



Elevation towards Banérsgatan,
Scale 1:400



View of corner towards the old SKF-factory

The construction consists of a double leaf masonry wall, where the inner leaf, built out of masonry blocks is load bearing, and the outer leaf of bricks create the facade.

A relief in the bond covers the first two floors of the building, accentuating the socle. The bricks continue down into the ground which creates a massive and permanent feeling. This is possible today, with frost resistant bricks, and a water pipe underground further protecting the brick.

The color of the brick is a light yellowish grey, which is made by clay with a high percentage of lime. The local clay on which Gothenburg is built, gault, is such a clay. The lowest courses of brick are dark green, which will handle the dirt from the ground better.

The roof is a flat roof, making the building look modern, while at the same time referencing the flat roof of the old SKF-factory.

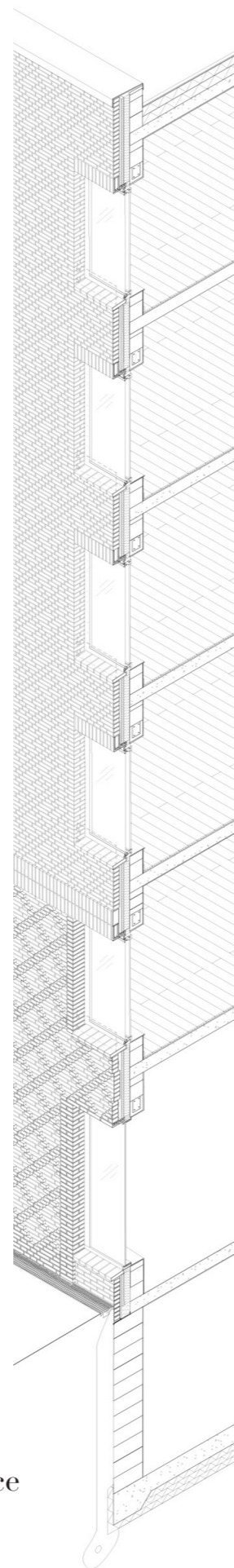

Section slice
Scale 1:100

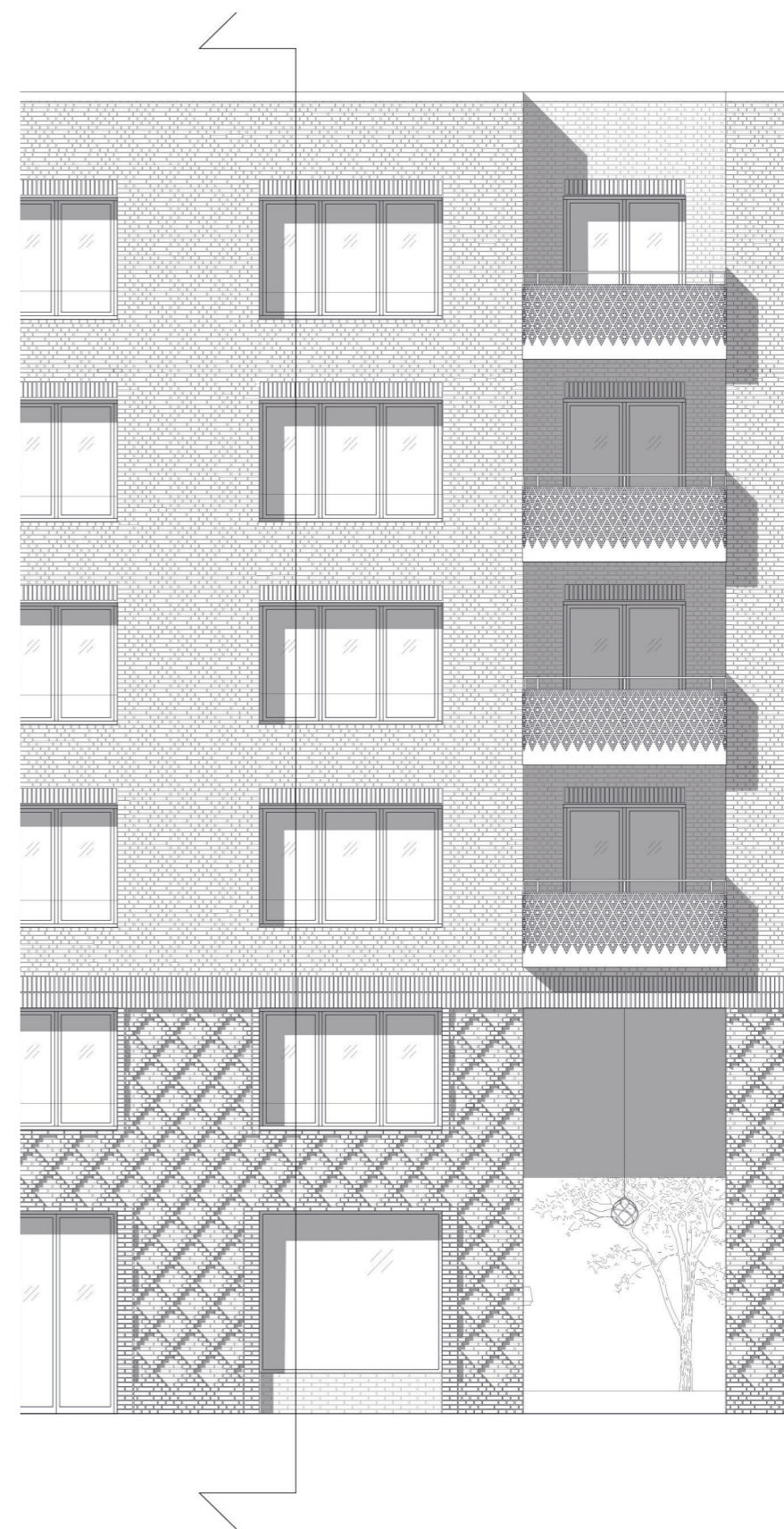

Elevation slice
Scale 1:100

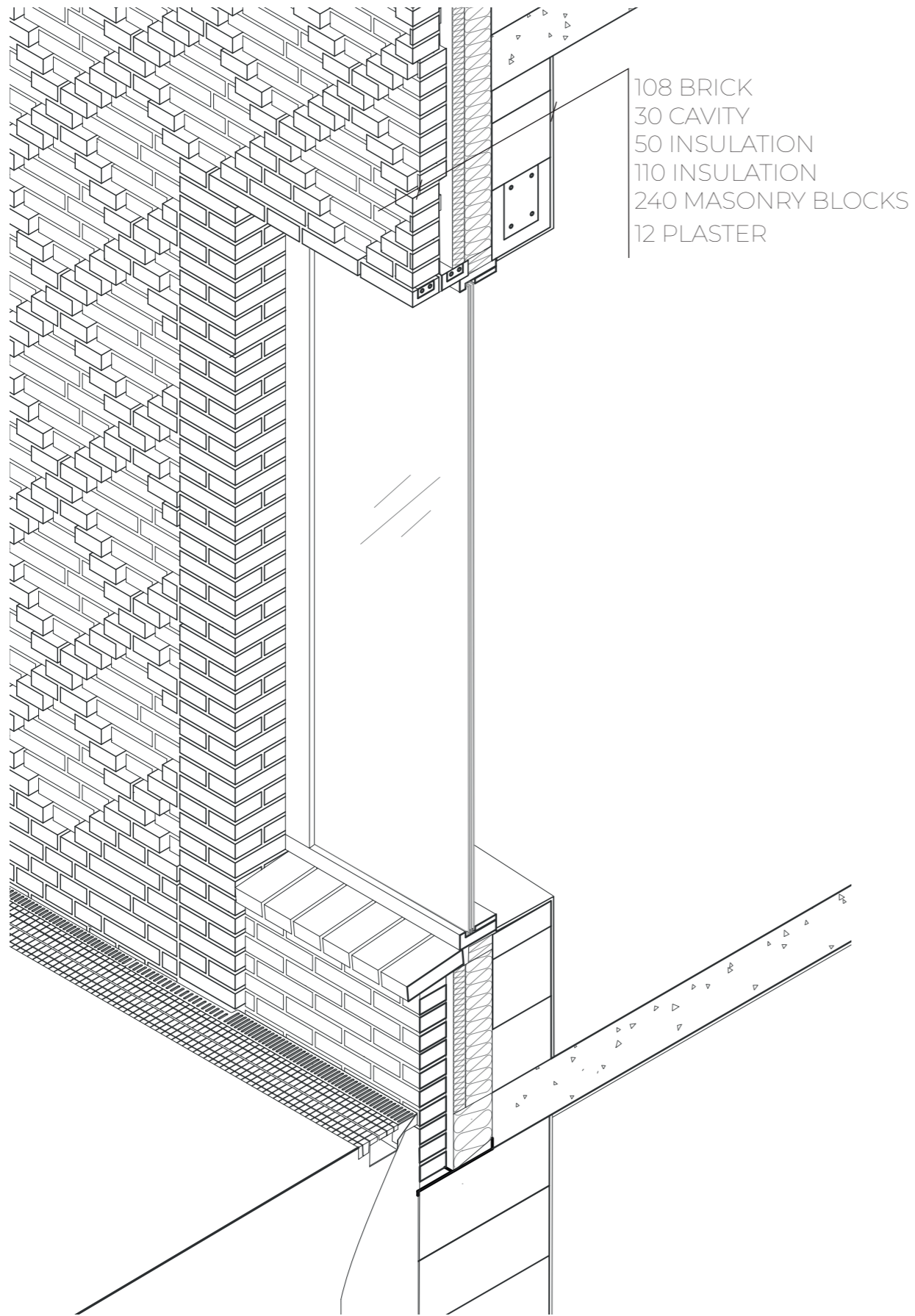

108 BRICK
 30 CAVITY
 50 INSULATION
 110 INSULATION
 240 MASONRY BLOCKS
 12 PLASTER

Axonometry, meeting with the ground
Scale 1:20

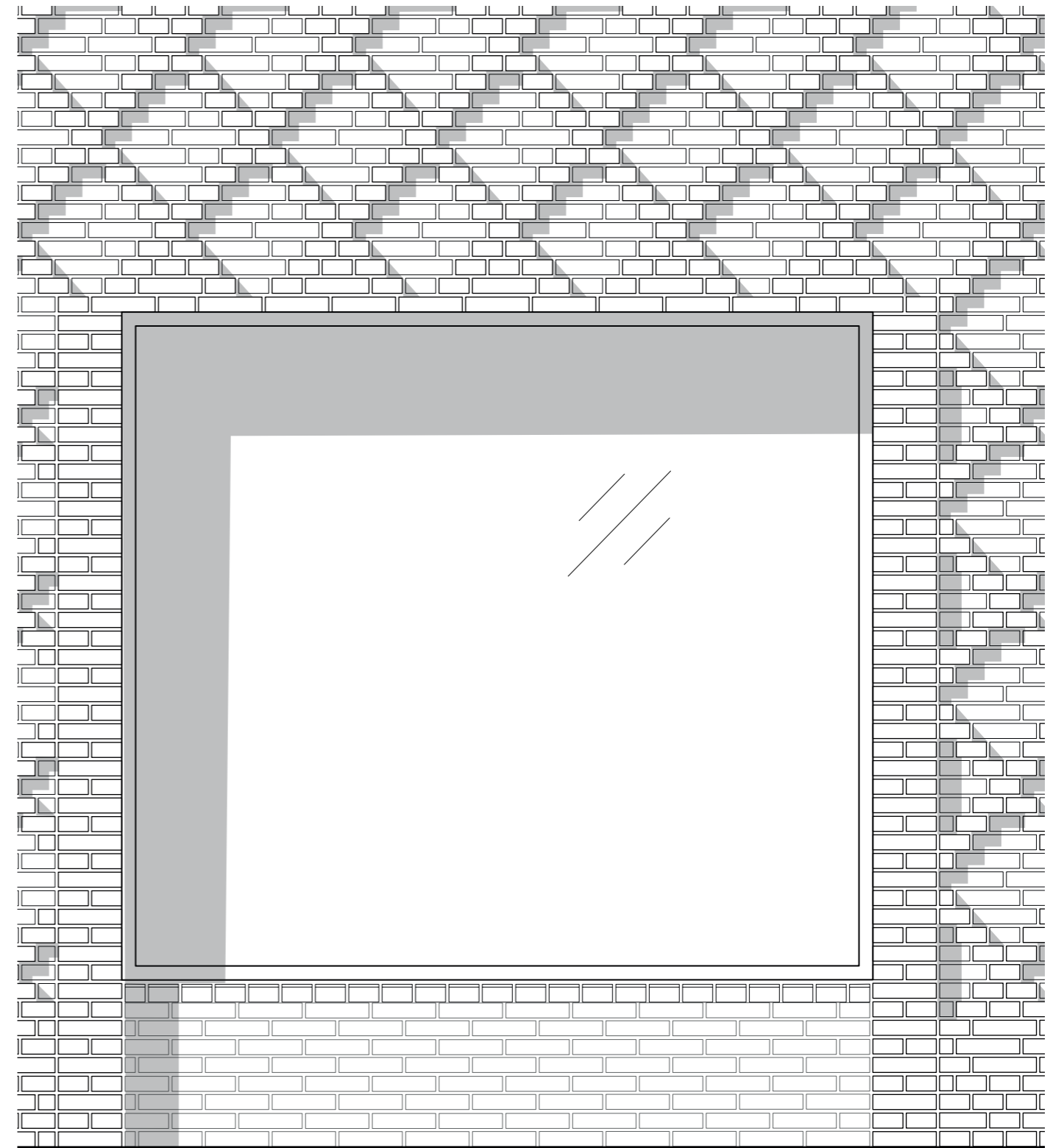

Elevation, meeting with the ground
Scale 1:20

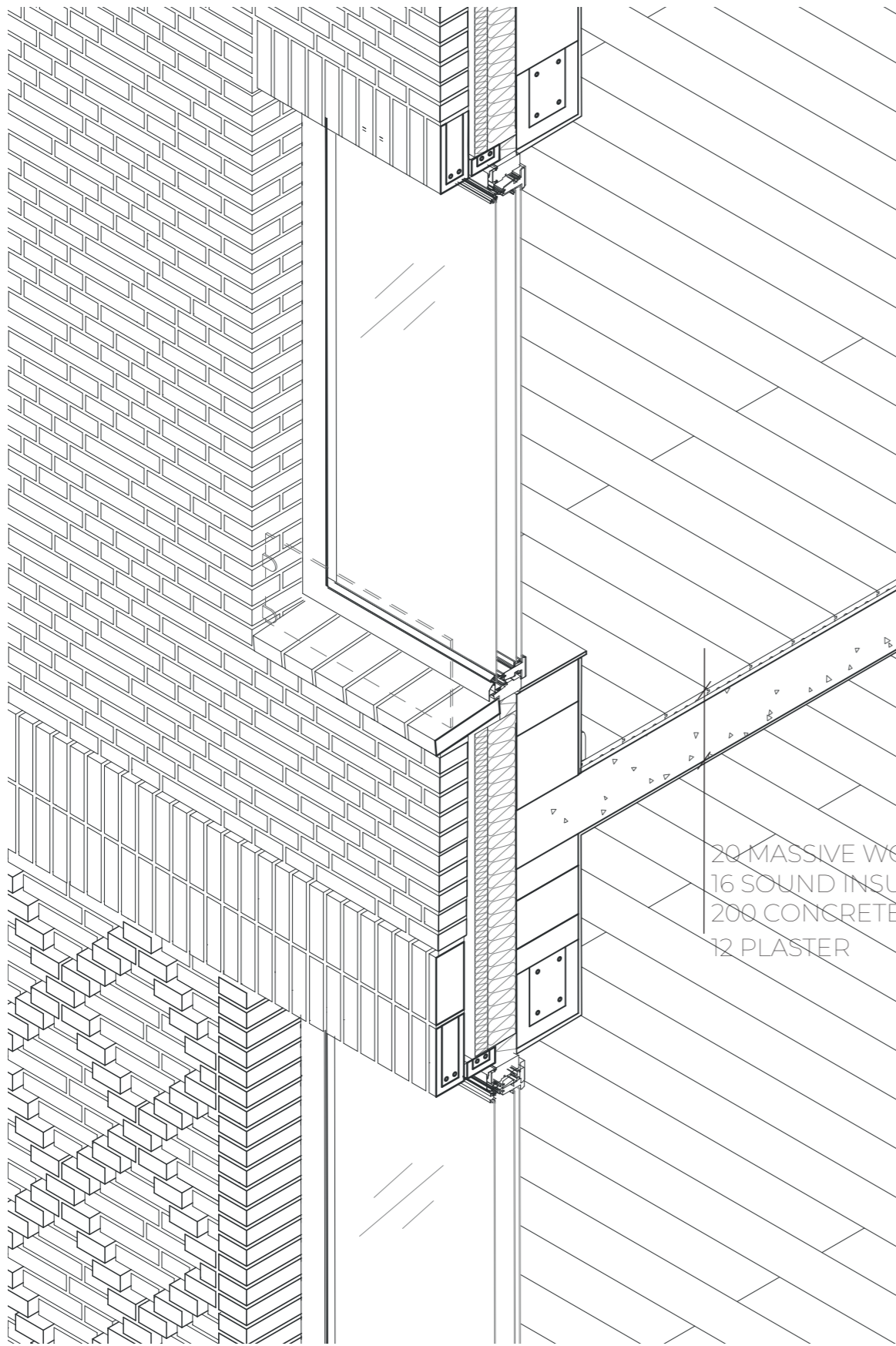

Axonometry, meeting between socle and floors above
Scale 1:20



Elevation, meeting between socle and floors above
Scale 1:20

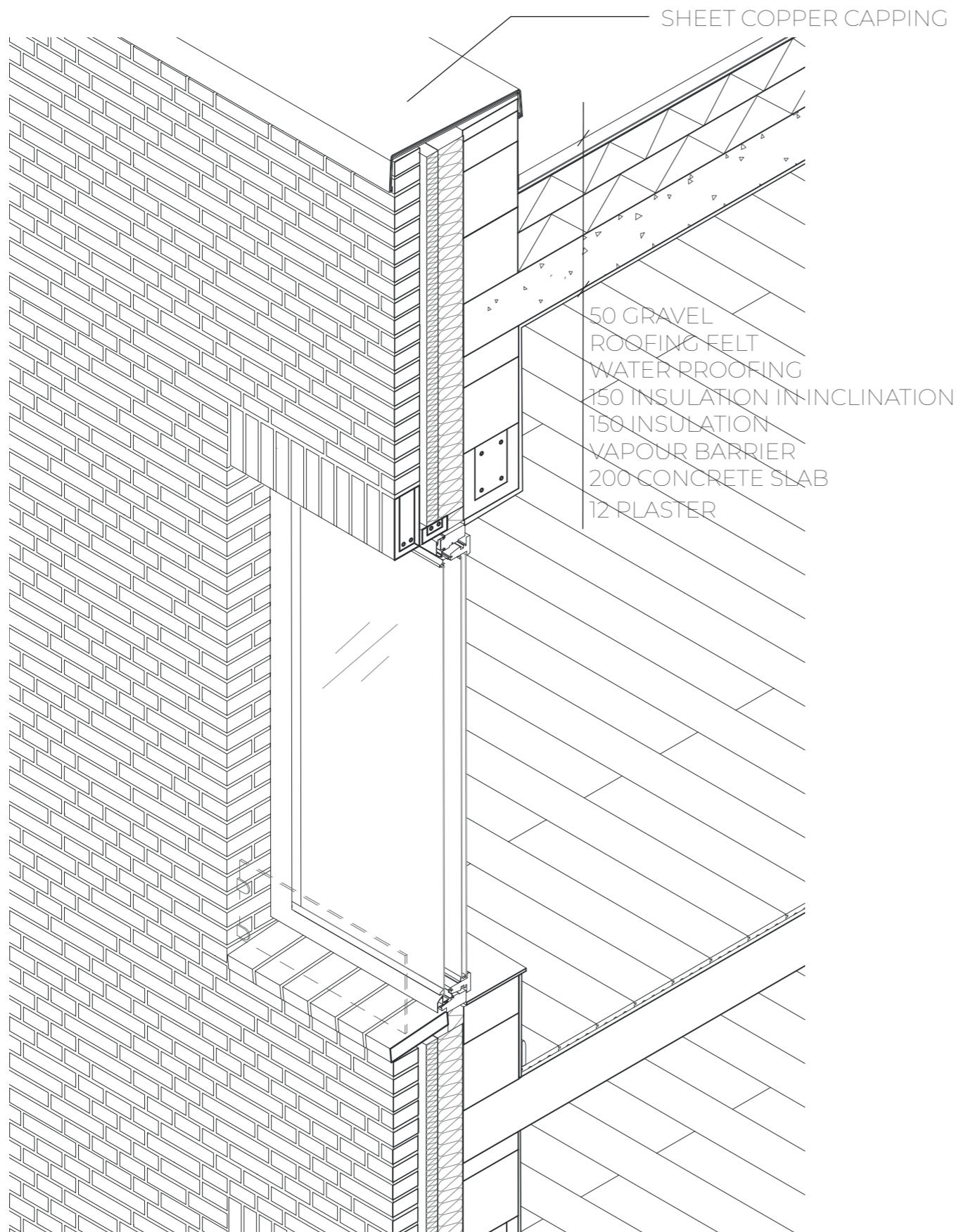

Axonometry, roof
 Scale 1:20

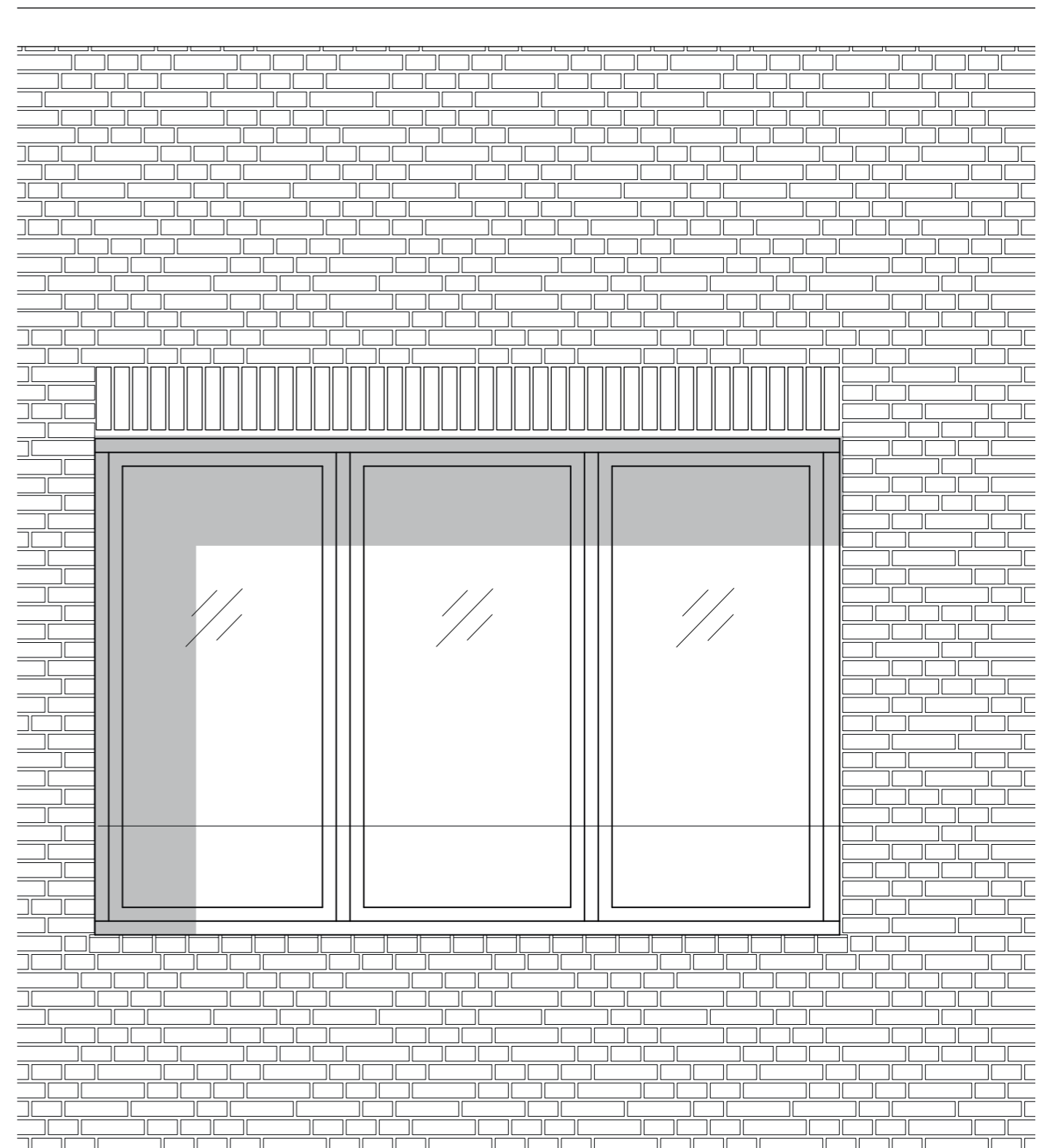

Elevation, roof
 Scale 1:20