



**CHALMERS**  
UNIVERSITY OF TECHNOLOGY

---



# Frequency Regulations From Wind Power

A Pre-study for Integrating Frequency Services for Wind Power Systems in Sweden Considering Tariffs

Master's thesis in Electric Power Engineering

KEVIN TU  
ARON YONIS

Department of Electrical Engineering  
CHALMERS UNIVERSITY OF TECHNOLOGY  
Gothenburg, Sweden 2020

---



MASTER'S THESIS 2020

# Frequency Regulations From Wind Power

A Pre-study for Integrating Frequency Services for Wind Power  
Systems in Sweden Considering Tariffs

KEVIN TU  
ARON YONIS



**CHALMERS**  
UNIVERSITY OF TECHNOLOGY

Department of Electrical Engineering  
*Division of Electric Power Engineering*  
CHALMERS UNIVERSITY OF TECHNOLOGY  
Gothenburg, Sweden 2020

Frequency Regulations From Wind Power: A Pre-study for Integrating Frequency  
Services for Wind Power Systems in Sweden Considering Tariffs  
ARON YONIS  
KEVIN TU

© KEVIN TU, ARON YONIS, 2020.

Supervisor/Examiner:  
Ola Carlson, Department of Electrical Engineering  
Chalmers University of Technology

Master's Thesis 2020  
Department of Electrical Engineering  
Division of Electric Power Engineering  
Chalmers University of Technology  
SE-412 96 Gothenburg  
Telephone +46 31 772 1000

Typeset in L<sup>A</sup>T<sub>E</sub>X  
Printed by Chalmers Reproservice  
Gothenburg, Sweden 2020

Frequency Regulations From Wind Power: A Pre-study for Integrating Frequency Services for Wind Power Systems in Sweden Considering Tariffs

Master's thesis in Electrical Power Engineering

KEVIN TU

ARON YONIS

Department of Electrical Engineering

Chalmers University of Technology

## **Abstract**

The driving force of developing and integrating ancillary services from renewable resources are a process that is continually developing since the generation and use of electricity is changing in one way or another. A part of this transition towards renewable energy resources includes extensive measurements and analysis for a secure and stable power system. With the increase of integration of wind turbines in power systems are ancillary services provided by the wind turbine (WT) and the basic concepts studied. To comprehend how the frequency services are provided are different grid codes and countries observed to provide the basics of how Sweden is operating in comparison. Furthermore, the main purpose of the project is to model and simulate a WT with the capability of power curtailment for providing support towards frequency stabilization. By designing the WT with variable speed and pitch regulation are active power control method obtained. Through the simulations are different scenarios conducted where symmetric regulation of the power were presented. The different cases indicates that wind power systems are rapid and versatile, which corresponds towards a more reliable grid system. Nevertheless it is important to consider the market pricing for the frequency services where the scenarios are evaluated. This paves the way for suppliers of wind energy to reflect upon if frequency regulation is something to consider in the future.

Keywords: Wind turbine, WT, Regulation, Power curtailment, curtailment, active power control, Frequency regulation, Ancillary service, Frequency control, SvK, Nord Pool



## Preface and Acknowledgements

This project is the final piece of the master's programme Electrical Power Engineering at Chalmers University of Technology. It was carried out during the spring semester of 2020 at the division of Electrical Power Engineering, department of Electrical Engineering.

First of all, we would like to express our sincere appreciation to our supervisor and examiner Ola Carlson for his guidance and support throughout the whole project. We would also like to express our gratitude for his engagement in our discussions and for his inputs throughout the project. Many special thanks to our friend James Afif for spending his invaluable time with us through the late study nights during the COVID-19 pandemic.

Lastly, we would like to thank our families and friends, even though did not contribute to the project, for their support and love at any time. Their physical presence and sharing our frustrations for all the frenzy discussions made it possible to reach our milestones. Without their support and love, this project could not have reached its goal.

Kevin Tu and Aron Yonis, Gothenburg, June 2020



---

## List of Acronyms

ACE	Area control error
AGC	Automatic Generation Control
aFRR	Automatic Frequency Restoration Reserve
APC	Active Power Control
BRP	Balancing Service Provider
ENTSO-E	European Network of Transmission System Operators for Electricity
FCR	Frequency Containment Reserve
FCR-D	Frequency Containment Reserve for Disturbances
FCR-N	Frequency Containment Reserve for Normal Operation
FFR	Fast Frequency Response
FRR	Frequency Restoration Reserve
mFRR	Manual Frequency Restoration Reserve
NERC	North American Electric Reliability Corporation
PMSG	Permanent Magnet Synchronous Generator
RR	Replacement Reserve
SCIG	Squirrel Cage Induction Generator
SvK	Svenska Kraftnät
SWPA	Swedish Wind Power Association
TSR	Tip Speed Ratio
TSO	Transmission System Operator
WT	Wind Turbine
WRSG	Wound Rotor Synchronous Generator
WRIG	Wound Rotor Induction Motor

# Contents

<b>1</b>	<b>Introduction</b>	<b>1</b>
1.1	Background . . . . .	1
1.2	Related Work . . . . .	2
1.3	Problem Statement and Approach . . . . .	2
1.4	Limitation . . . . .	3
<b>2</b>	<b>The Wind Turbine</b>	<b>4</b>
2.1	Basic Concepts of Wind Turbines . . . . .	4
2.2	Electrical Generators . . . . .	5
2.2.1	Wind Turbine Typologies . . . . .	5
2.2.2	Power Electronics . . . . .	5
2.2.3	Wind Turbine Configurations . . . . .	6
2.3	The Aerodynamics . . . . .	8
2.4	Power Control Concepts . . . . .	9
2.4.1	Pitch Regulation . . . . .	9
2.4.2	Stall Regulation . . . . .	9
2.5	Power Curve . . . . .	10
<b>3</b>	<b>Frequency Regulation</b>	<b>13</b>
3.1	Frequency Terminology . . . . .	13
3.2	Frequency Control Service . . . . .	14
3.2.1	Frequency Restoration Reserve . . . . .	14
3.2.2	Frequency Containment Reserve . . . . .	14
3.2.3	Fast Frequency Response . . . . .	15
3.2.4	Review of Frequency Services . . . . .	15
3.3	Frequency Capability of The Wind Turbine . . . . .	17
<b>4</b>	<b>International Overview and Experience</b>	<b>18</b>
<b>5</b>	<b>Domestic Frequency Regulation</b>	<b>21</b>
5.1	Introduction . . . . .	21
5.2	Nord Pool . . . . .	21
<b>6</b>	<b>Modelling and Simulation</b>	<b>24</b>
6.1	Introduction and Overview . . . . .	24
6.1.1	Wind speed . . . . .	25
6.1.2	Reference Speed . . . . .	26

6.1.3	Aerodynamic Model . . . . .	28
6.1.4	Gearbox . . . . .	30
6.1.5	Pitch controller . . . . .	30
6.1.6	Integrating of APC Through Pitch Controller . . . . .	32
6.1.7	DC Machine . . . . .	34
6.2	Case overview . . . . .	39
6.2.1	Case 1: Low Wind Speed . . . . .	40
6.2.2	Case 2: Medium Wind Speed . . . . .	42
6.2.3	Case 3: High Wind Speed . . . . .	46
<b>7</b>	<b>Analytic Market Pricing</b>	<b>49</b>
7.1	Spot Market Price . . . . .	51
7.2	Generated Power and Potential Income . . . . .	53
7.2.1	Equilibrium Quantity Estimation . . . . .	56
<b>8</b>	<b>Concluding remarks</b>	<b>57</b>
8.1	Future works . . . . .	58
	<b>Bibliography</b>	<b>59</b>
<b>A</b>	<b>Appendix 1</b>	<b>I</b>
A.1	Day-Ahead Price for FCR-N between the months January and May 2020 . . . . .	I
A.2	Day-Ahead Price for FCR-D between the months January and May 2020 . . . . .	II
A.3	Day-Ahead prices in January, February and March 2020 . . . . .	III
A.4	Day-Ahead Price in April 2020 . . . . .	IV
A.5	Day-Ahead Price in May 2020 . . . . .	V
A.6	Generated Power . . . . .	VI

# 1

## Introduction

### 1.1 Background

Forecasts by the Swedish Wind Power Association (SWPA) shows that the wind power production in Sweden is estimated to deliver up to 40 TWh by late 2022, comparable to an installed power of 14 GW. This is a significant amount of increase in wind power in Sweden, and a possibility to eventually surpass hydro power as the leading power source in Sweden. Nuclear power and hydro power have a installed power of 7 GW and 16 GW, respectively. Furthermore, on windy days or during the summer seasons whereas the load is lower than rest of the year, the production is more favourable by wind power for the electric power production.

For that reason, to be considered or acknowledged as a leading power source, it also needs to qualify and have the services and functions to provide the necessary significant ancillary services that an electrical power system demands, which traditionally have not been done before by renewable energy resources [1].

An essential service is to contribute to frequency control within different requirements, to handle possible interruptions in the system. Other ancillary services includes voltage regulation, reserve capacity and inertia. A requirement for the electrical grid is that it should remain in a frequency balanced equilibrium, where the supply will continually meet the demand to avoid disruptions considering the impact on the frequency of the grid. As renewable energy production are displacing other existing resources, the uncertainty of these are the intermittent of the available resource. However, a crucial part of meeting the emission reduction targets is through decarbonisation of the power sector by integrating renewable energy sources.

Today in Sweden are these ancillary services mainly provided by hydro power plants, however as the demand for wind plants steadily increases, the question also arises in how wind plants can provide these services. Svenska Kraftnät (SvK), a transmission system operator (TSO) in Sweden, compensates producers with different tariffs for the different ancillary services provided. However, since these services have not been provided by any wind plants in Sweden before, there are no basis or experience for how the market and the technology will collaborate when providing it.

## 1.2 Related Work

Several researches have been conducted about WTs and their impact on the frequency stability for the electrical grid with assessments through different methods to manage ancillary services [1, 2, 3, 4]. Wind plants are progressively becoming more important in providing support in regulation of the grid frequency, as seen in countries like Spain, Denmark and Ireland, where wind plants are providing ancillary services within their power system [5].

The industry are continuously monitoring and developing different strategies, such as: inertia, primary and secondary responses, monitoring and maintaining of active power, forecasting and intelligent communication between individual turbines and plants. All these control strategies provide different types of ancillary services for the grid and are beneficial for the providers beyond the decarbonisation, as it may be profitable for them to provide these services through tariffs.

In addition to the industry there are also projects planned for future challenges. The project System development plan 2018-2027 [6], by SvK, is processing the rapid and comprehensive changes for a share of renewable electricity generation, distributed generation and changes in consumption patterns regarding the electrical grid.

The development with respect to frequency stability revolves around a more dynamic approach, which ensures the amount of ancillary service in the operating stage, faster responsive services, frequency stability control and improved tools to estimate how much inertia is available in the system [6]. Furthermore, a report from 2010 suggest that when replacing conventional power sources with a large percent of WTs, without frequency control methods, it will have a significant impact on the stability of the grid frequency [5]. As more share of wind power is integrated in power systems are more projects and development tests conducted.

## 1.3 Problem Statement and Approach

The purpose of this project is to provide a basic overview for both the technical and financial possibilities, apropos of tariffs, and possible ancillary services from wind plants to assist in frequency regulation. By performing simulations for different scenarios, it will become possible to evaluate and highlight the interests considering the compensation for the ancillary services for the energy market. To comprehend the issue, certain sub-goals needs to be emphasised in order to achieve the aim of this project:

- The basic concepts of the WT and how the aerodynamics and physical principles affect the turbine.
- Theoretical investigation on the ancillary services currently in use and obtaining the different requirements, configurations and management for the different services.
- Understanding of the different frequency control services and how they are provided within varying organisations and highlighting the international and domestic experience regarding frequency services.

- Modelling of a WT with integrated power control and simulation based on different actual scenarios.
- Analytic market pricing for the economical aspect, highlighting the tariffs and compensation for forgoing the energy market.

## 1.4 Limitation

As this is a preliminary research, the simulation of the WT will be a simplified model of a real test plant without consideration of the mechanical wear for the WTs and the lifetime cost. Since, the simulation model will represent a real test plant, the power coefficient values are given and are not computed.

There are numerous of aerodynamics factors that are not explicitly included when developing the simulation model, although a brief mention about the aerodynamics and WT properties are introduced and recognised. The simulation results are only valid for the specific WT that are simulated, as different models could give different results. The simulation considers only the power production during operation and not during the transients of the wind power plant.

No specific methods for development are introduced, but rather highlights of frequency control methods that can be used. No studies about weather impacts and maintenance requirements are examined, and power electronic converts are left to manufacture's design. The results are evaluated with no development of how the control is implemented, but rather demonstration that it can be achievable.

Although the results, can the results still be insufficient for a complete broad analysis. A complete analysis will likely require studies spanning several months. The computational model will not consider severe change in wind speeds but rather constant winds speeds scenarios. Hence, no aspects about the seasonality and temperature will be examined either.

The survey of the analytic market pricing does not consider the cost of the investment, fixed cost, nor the cost of the components and the maintenance, from the increased in wear and tear when operating at a lower plant efficiency, but only a survey of the WT during operation and the quantity of services provided. Thus, the evaluation of the market pricing is only focused on the pricing during operation.

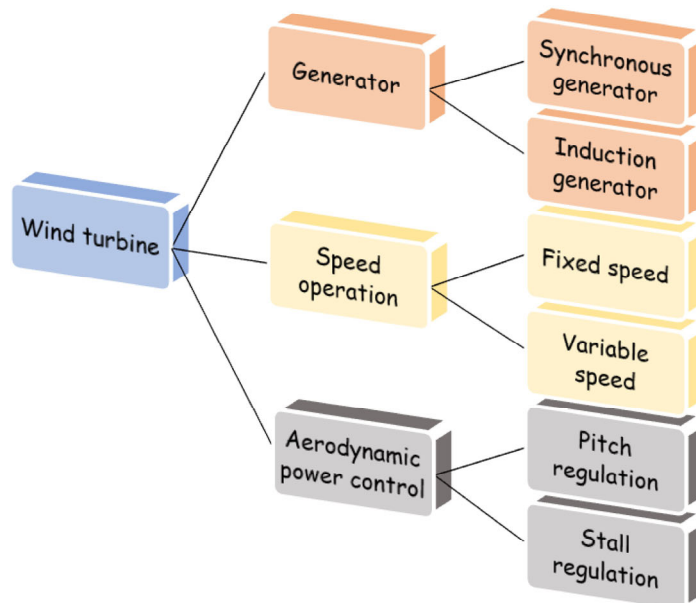
# 2

## The Wind Turbine

### 2.1 Basic Concepts of Wind Turbines

There are different ways to convert kinetic energy into electricity and a WT operates in a simple principle. A WT is a device that converts kinetic energy contained from the air into mechanical energy, which spins a generator that transforms the mechanical energy into electrical energy. Although the different designs and types of WTs are the functionality still the same with inevitable trade offs. The designs of the WTs are limited by their practical usefulness, as there is a limitation of their design, particularly the WT itself and the wind rotor.

Furthermore, in order for the mechanical to energy conversion production to materialize, other equally important components must be considered such as the drive train, generator and a variety of control and auxiliary systems. Figure 2.1 illustrate the main diverse components when constructing a WT.



**Figure 2.1:** The different possibilities to consider when designing a WT.

## 2.2 Electrical Generators

The electrical system includes all the aforementioned components and the focal point for the preceding components is the generator. The WT generators can be divided into two general types: the synchronous and the induction generator. An understanding of these two generators sets a prerequisite for a deeper understanding of the most important components and of the behaviour for the concepts of WTs, since it is the generators that comply its speed to regulate the frequency deviation. The mechanical construction is the same for both generators where it consists of a stator and rotor, however the main difference is the excitation of the generators and the different mechanical speeds.

Synchronous generator is operating at synchronous speed and can be excited with direct current. During idle is the generation at zero and depending on positive or negative value will the generator will either produce or consume energy. For an induction generator is the excitation supplied by a magnetizing current which is drawn from the electrical grid. The interaction between the rotating magnetic field and the rotor winding results in a torque acting on the rotor and depending on if the rotor speed is faster or slower than the synchronous speed will the generator either produce or consume energy.

### 2.2.1 Wind Turbine Typologies

Besides the generator, are the WTs either designed for variable speed (I) or fixed speed (II) operation to fit the electrical system. As the technology continues to mature the WT industry have since moved from fixed speed to variable speed operation due to the advantages [7, 8].

Variable speed (I) operation is when the rotor speed operates at a wider range and allows the generator and rotor speed to vary proportional to the wind speed during operation, which also contributes assistance into frequency balancing and optimal aerodynamic performance. Variable speed operation can be achieved by different configurations. One common configuration is by employing a synchronous generator that operates at varying speed using power converters that ensures that the speed matches the frequency and the utility grid [9].

Fixed speed (II) is not explicitly described in this chapter as variable speed, due to the recent development of the turbines and how this project is going to be conducted. However, the primary advantages of variable speed over fixed speed are described in [10, 11]. Nevertheless, fixed rotor speeds operates as at the same speed independently on the wind conditions and cannot be varied. Hence, the lower efficiency and recent change towards variable speed operation. One of the benefits of still resorting to fixed variable speed is its simple construction, the lower cost and robustness.

### 2.2.2 Power Electronics

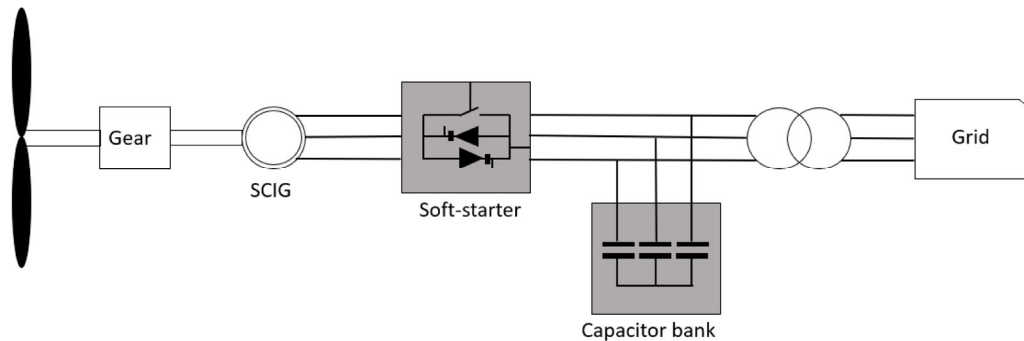
WTs requires power electronic systems, that adjust the necessary generated power to regulate the frequency of the grid. Power electronics devices contributes optimisation

by regulating the flow of the electrical energy. In broader terms, are power electronics used to process and control the flow of the energy by supplying the right amount of energy required and changing the characteristic of the WT. However, regarding WTs it is divided into two main properties. Controllable frequency where it allows variance in energy consumption, soft drive train, load control, gear less option and reduction of noise.

The other property is power plant characteristics which can be associated with controllable active and reactive power, voltage stability, power quality in forms of reduce flicker, low harmonics and limited short circuit power. As power electronics are gradually developing like the WT are those control parameters necessary as a interface intermediate between the WT and the grid. All these devices increases the performance of the WT which is limited to the investment [12].

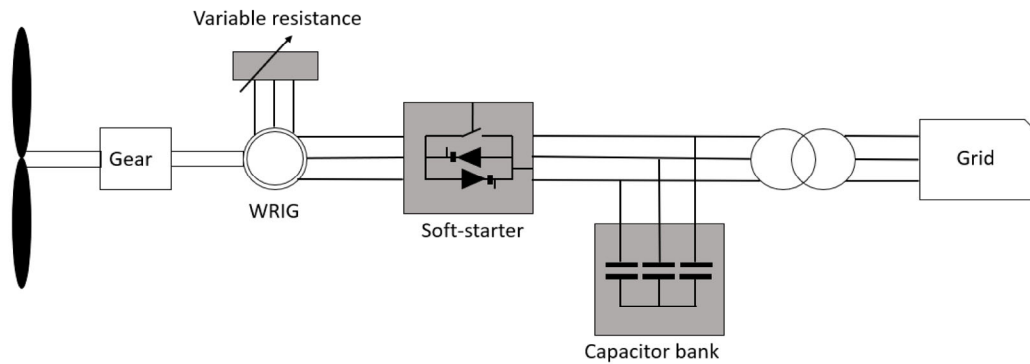
### 2.2.3 Wind Turbine Configurations

This following chapter illustrates and categorize the most commonly applied WT configurations by their ability of controlling the speed and what type of power controllers that are used. The defined types are referred as Type I,II,III and IV by the International Electrotechnical Commission (IEC) and can be seen in Figure 2.2-2.5, respectively. More about these WT types can be read at [12].



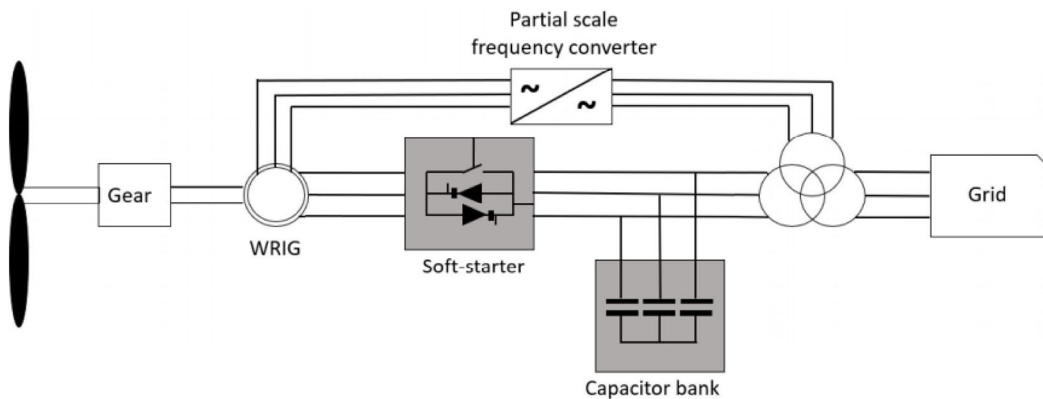
**Figure 2.2:** Typical WT configuration of Type I. *Note:* SCIG = squirrel cage induction generator

Type I configuration is a fixed speed turbine with an asynchronous squirrel cage induction generator (SCIG) directly coupled to the grid through a transformer. This configuration consist of a capacitor bank due to the drawn reactive power from the grid as a reactive power compensation. The soft-starter connection smoothens the grid connection.



**Figure 2.3:** Typical WT configuration of Type II. *Note:* WRIG = wound rotor induction generator.

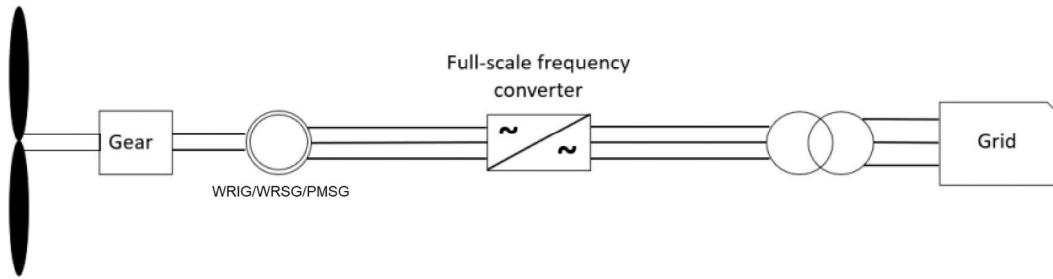
Type II configuration corresponds to a limited variable speed turbine with a variable generator that is connected to a variable resistance. The generator, WRIG, is directly connected to the grid through a transformer and the configuration consists of a soft-starter and a capacitor bank. The variable resistance is used for controlling the rotor resistance and depending on the size it changes the range of the dynamic speed. This resistance mounted on the rotor eliminates the costly slip rings that needs brushes and maintenance.



**Figure 2.4:** Typical WT configuration of Type III. *Note:* WRIG = wound rotor induction generator.

Type III configuration is known as the doubly fed induction generator (DFIG), which also corresponds to a limited variable speed turbine with WRIG. This configuration consist of a partial scale frequency converter with the task to perform reactive power compensation and smoother the grid connection. Furthermore, this configuration has a wider range of dynamic speed control compared to Type II that is also dependable on the size of the frequency converter.

Type IV configuration corresponds to a full variable speed turbine connected to the grid trough a transformer and a full-scale frequency converter. The full-scale frequency converter is used as reactive power compensation and to smoother

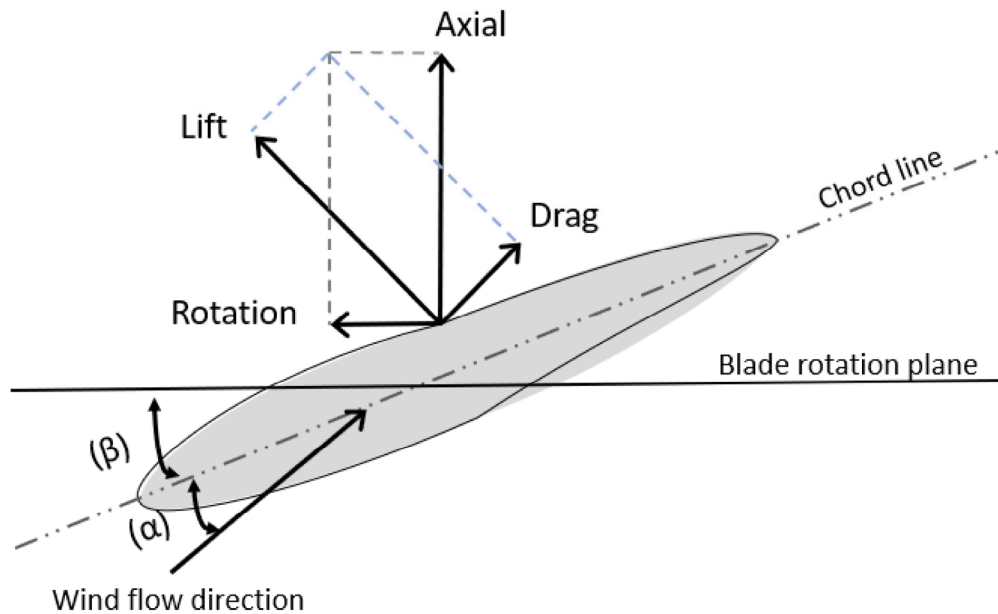


**Figure 2.5:** Typical WT configuration of Type IV. *Note:* WRIG = wound rotor induction generator; WRSR = wound rotor synchronous generator; PMSG = permanent magnet synchronous generator.

the grid connection. This generator can be excited electrically by a permanent magnet, PMSG, or through WRIG or WRSR. Furthermore, the gearbox on this type configuration can be replaced by a direct driven multi pole generator.

## 2.3 The Aerodynamics

The two primary forces that act on a WT are the rotors lift and drag force, which can be explained as perpendicular and parallel to the direction of the wind, respectively. These forces can be defined as axial- and rotation forces which can be seen in Figure 2.6. This theory can be explained by Betz's momentum theory, which is based on a modelling of a two-dimension flow through the actuator disc [13].



**Figure 2.6:** The force triangles of a rotating wind turbine blade.

Another factor that decides the aerodynamics of the rotors are the state of the

flow behind the rotor, which can be described as wake interactions. WTs are often installed in wind farms to reduce cost of transmission lines, operation and maintenance, and a consequence of that is the energy from the wind. The turbine creates wakes that extend downstream, which forms lower wind speeds and higher turbulence than the surrounding wind. This results to a lower significant energy that can be extracted from the available wind, which also corresponds to a lower generating power and higher mechanical stress load on the WTs. More of the consequences are in the subjects of different researches [13, 14, 15]. Beyond the wake interactions is the WT also exposed to tower shadow effect and wind gradient, which both contributes to the power fluctuations of the WT.

## 2.4 Power Control Concepts

Considering the efficiency, mechanical stress and likewise the stability of constant rated output power; the WT needs aerodynamic power controllers to ensure that the operation is always at the desired operation point. By employing power controllers to decide the properties of the WT are the controllers adapting for the intermittent of the available wind capability and the wind speed.

At high wind speeds, can the generated power exceed the rated power and to reduce the mechanical stress and protect the WT, there are different measurements that can be employed to cope with that. To ensure the security for the mechanical aspects of the WTs are the turbines usually designed to halt past a certain cut-out speed for safety reasons. Conversely, for lower wind speeds are the power plant halted when the wind speed is lower than the cut-in speed.

### 2.4.1 Pitch Regulation

By mechanically adjusting the rotor blade pitch angle can the WT operate at the desired output and within limits. In principle, by adjusting the angle of the rotor blades is the power production limited, higher angles for power absorption and likewise, lower angles for higher power production. The blade pitches accordingly to the wind speed to yield the maximum power, and in case of stronger winds are the energy wasted for ensuring the safety of the WT. The advantages of pitch regulation can be associated to the control of the power flow during all stages of operation and reduction of aerodynamically damping. The disadvantages are the cost and complexity that comes with the control system [16].

### 2.4.2 Stall Regulation

Another control strategy to deal with the high wind speeds are stall-regulated methods. The rotor blades are designed in a way such that when either the wind speed is too high or the aerodynamic torque, the power production decreases with increase in wind speed above a certain speed. This control method works due to regions of the rotor blade are stalled propagating from the hub. The high wind speeds creates turbulence which prevents the lifting force acting on the rotor blades. Hence, the higher the wind speeds the worse it performs in terms of energy production.

This method is simple and cheap compared to pitch regulation, however the drawbacks are the efficiency, and assisting during transient of the WT [16]. Regardless of control regulation will fluctuation always occur due to the aerodynamics.

## 2.5 Power Curve

Betz's law concludes that regardless of the design of the WT, there is only a certain amount of maximum kinetic energy that can be extracted from the wind. The maximum kinetic energy that a turbine can theoretically capture from the wind are:  $C_{p.betz} = \frac{16}{27}$ , which is known as Betz' coefficient [17]. However, it is worthwhile to specify that this implication is derived for a unrealistic ideal scenario. In practice is the coefficient value always lower, in the range of 35-45% [18].

Taking into consideration of all the aforementioned aerodynamics effects on the WT is the power coefficient always lower than Betz's coefficient,  $C_{p.betz}$ . This is mostly due to the wind having less energy and speed when passing the wind rotor blades. As a matter of fact,  $C_p$  is varying for different manufactures and is usually provided for the different wind speeds. The power coefficient for the simulated WT used in this project are given in Figure 2.7 with a constant pitch angle.

Moreover, when operating at variable speed a constant TSR can be maintained by using the collective blade pitch controller by pitching the angle for an optimal aerodynamic performance. The fraction of the available wind power that the WT can harvest is a quantity that can be expressed as  $C_p$ . Thereby, the power coefficient becomes a function of  $\beta$ , the collective blade pitch, and  $\lambda$ , TSR. The ratio the between actual wind speed and the tangential speed of the tip can be calculated by:

$$\lambda = \frac{\textit{tangential velocity of the rotor blade tip}}{\textit{wind speed}} = \frac{\omega_r R}{v_w} \quad (2.1)$$

where  $R$  stands for the rotor radius,  $\omega_r$  rotational speed of the rotor in radians and  $v_w$  the wind speed. Figure 2.8, presents the relationship between the  $\lambda$  and  $C_p$  for the simulated WTs with varying pitching angles ranging from  $0^\circ$  to  $40^\circ$ .

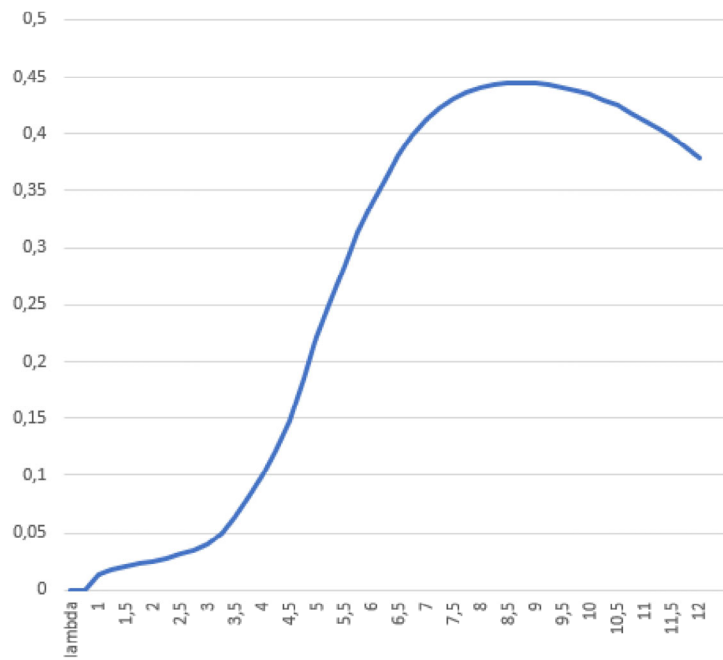


Figure 2.7: The relationship between  $C_p$  and TSR with constant pitch angle of  $0^\circ$ .

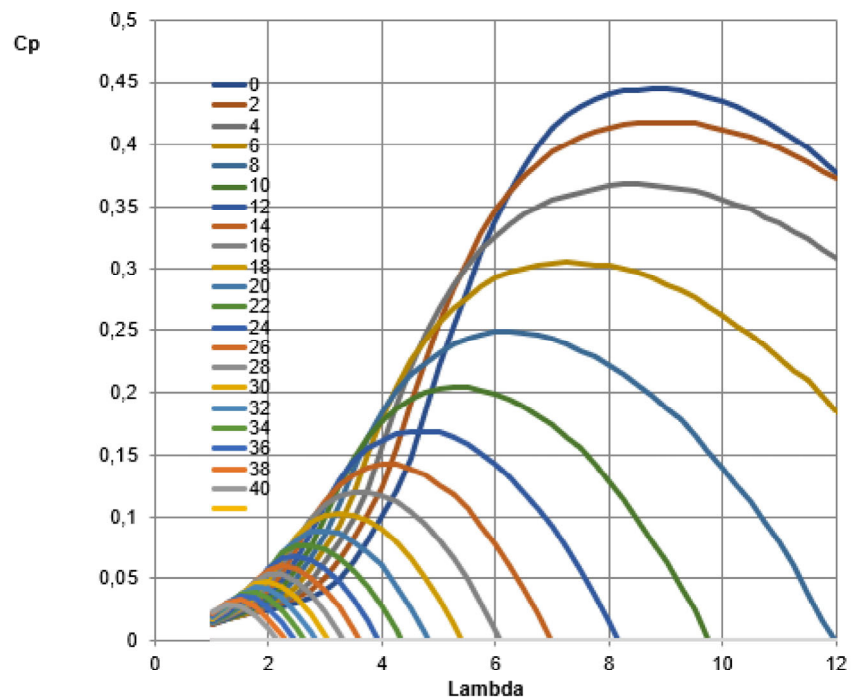


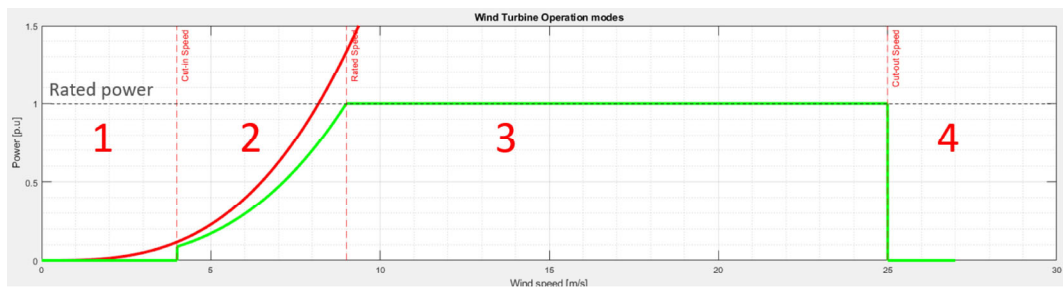
Figure 2.8: The relationship between  $C_p$  and TSR with varying pitch angles.

As the nature of the wind power is fluctuating and intermittent, several problems are faced when recovering the available power. The available power contained in the wind that can be recovered by the WT is defined as:

$$P = \frac{1}{2} \rho A v_w^3 C_p \quad (2.2)$$

where  $P$  is the power,  $\rho$  the air density [ $kg/m^3$ ],  $A$  the swept area of the rotor perpendicular of the wind,  $C_p$  the given power coefficient and  $v_w$  the wind speed.

Figure 2.9 showcases a simplified overview of the four different operating region zones, where the red line is the available power and the green line the extracted power. For operation region 1 is the WT halted as the wind speed is too low for the WT to operate. For operation region 2 is the blade pitch angle held at constant,  $\beta = 0$ , for power extraction maximization. For operation region 3 are the speed and power limited,  $\beta > 0$ , as the pitch controller regulates. At operation region 4 is the WT halted due to high wind speed.



**Figure 2.9:** The different operating region modes for a WT power curve.

# 3

## Frequency Regulation

### 3.1 Frequency Terminology

When the system is shifting in frequency the alterations are showing that the system either needs more or less power production. When the frequency is lowered, the power demand is higher than the power supply and vice versa. As the frequency needs to be adjusted, there are different methods that are usually presented when controlling the frequency. This chapter provides explanations of some key terms that are used regarding frequency regulation.

**Active power control:** Is one of the varying methods to integrate the WTs for the interconnected grid systems. Active power control (APC) is done by curtailing the output power to compensate for fluctuations and unplanned frequency events. The method can be achieved by pitch regulation, to reduce the output power to the desired output at any moment. This makes it possible to contribute to ancillary services.

**Area control error:** When frequency deviation occur in the power system, there are (TSOs) that calculates and estimates the supply and demand of the different power outputs in the system in a scheduled way rather than actual generation. This is to maintain the anticipated production and load within measured values with account to the power flows concerning the frequency equilibrium. Area control error (ACE) presents the imbalance and mismatches within the system in real-time value, where automatic generation control is derived from [1].

**Automatic generation control:** (AGC) is a system responsible for the adjustment of the power output from different power plants in a interconnected electrical power system. As a power system is constantly shifting in load on account of demand and supply [1], the decision on whether the load demand is high or low is made by reviewing the systems frequency, generated power, and transmitted power [19].

**Inertia:** Refers to kinetic energy in a interconnected system, which allows the TSOs to re-balance the system to overcome the immediate imbalance that occurs due to the frequency deviation in the grid, through different control methods. When the frequency fluctuates, the active power regulations from WTs will compensate for it by either reducing or increasing the generation. Inertia is described as the quantity of rotating kinetic energy which rotates at the same nominal frequency.

## 3.2 Frequency Control Service

To maintain the balance between the energy production and consumption in the Nordic regions are different services provided. The system services are mainly traded through the Nord Pool market, see Chapter 5.2, where users bids and sell power electricity contracts. This chapter covers some of the most common system services available today, depending on where and when it is needed, the prequalifications for the varying frequency services and how they are traded within the market.

### 3.2.1 Frequency Restoration Reserve

Frequency Restoration Reserve (FRR) can be defined as the active power reserve available to restore the frequency to its nominal value and operates at synchronous frequency control areas, operated by TSOs. FRR can be provided in two modes: automatic and manual activation. Automatic frequency restoration reserve (aFFR) is a frequency service with the purpose to restore the system frequency with automatic activation.

Manual frequency restoration reserve (mFRR) has the same purpose by restoring the frequency to its nominal value, however, the difference is that mFRR also relieves other faster services to make sure that the faster frequency services are available for next unbalanced frequency circumstance. These two services is known as secondary control and tertiary control respectively and are traded in separate markets [19].

Replacement Reserves (RR) is known as the active power reserve to support or resupply FRR, to ensure that FRR is available for the next unplanned event. RR is a balancing service that is currently not traded in the Nordic market [6].

At present, is the power system requiring aFFR to produce the full necessary power output in 120 seconds and start to act in the system within 30 seconds and for mFRR is it a activation time of maximum 15 minutes. The services are traded with varying minimum bids depending on organisation for the TSO. The reserves for up and down regulations are traded in separated markets [20, 21, 22].

### 3.2.2 Frequency Containment Reserve

Frequency Containment Reserve (FCR) is a frequency control service, with the task to prevent frequency unbalances when fluctuations occurs during normal operation and in case of disturbances. This is done by power curtailment where the production capacity is reserved, given available resources, for reducing or increasing the production to contain any frequency deviations.

FCR is divided into two reserves, normal (FCR-N) and disturbance (FCR-D), and is known as primary control. FCR-N is usually used in normal operation and has the task to balance the frequency automatically until it stabilizes, the trigger for FCR-N is when there is a deviation within 0.1 Hz. FCR-D is used during disturbed operation and is automatically activated within 30 seconds when the frequency is below 49.9 Hz or above 50.1 Hz.

FCR-N is an asymmetric system which means that the frequency can be regulated in both ways, while FCR-D is at this point used for balancing the frequency

upwards, but has the capacity to balance it downwards [6, 19].

### 3.2.3 Fast Frequency Response

Fast Frequency Response (FFR) is the definition of injection active power to correct imbalances within the frequency system. A system service that regulates rapidly with the purpose of counteract the deviation of the frequency. This service refers to rapid deliveries of generally shorter than two seconds or less and responds faster than FCR-N. FFR is not currently used in the Nordic market yet, although the development of introducing FFR into the Nordic market is underway [6, 23].

FFR should be able to support two different time durations, long and short, which have the same activation requirements, and the duration for both frames are 30 and 5 seconds respectively. However, for the deactivation is the requirements different and the FFR entities must be able to prepare for the next event withing 15 minutes. Since it has been concluded that under frequency situation is more critical than over frequency are FFR mostly defined for frequency drops than frequency rise [23, 24]. The three different requirements that can be chosen depending on the situation are found in Table 3.1.

**Table 3.1:** Requirements for the frequency control service FFR [24].

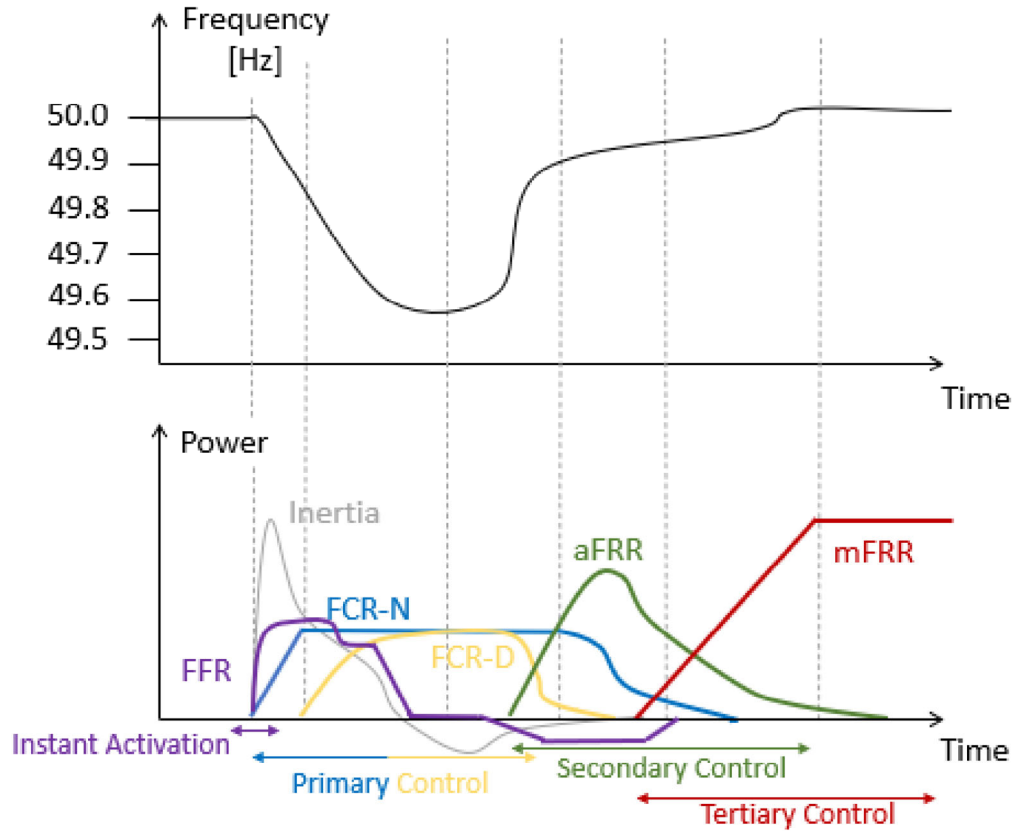
Activation level [Hz]	Maximum full activation time [s]
49.5	0.7
49.6	1
49.7	1.3

### 3.2.4 Review of Frequency Services

The different frequency services are provided partially by a supplier and are co-operating gradually by TSOs until the frequency is restored. Figure 3.1 is illustrating an fictional example of a declining frequency in Sweden and how the different services can provide with its predetermined requirements to restore the balance until its nominal value. Table 3.2 gives an overview for the categorised control schemes and the time frames for each service [25]. The Table 3.3 illustrates the prerequisite for the aforementioned system services in Sweden and how they are provided.

**Table 3.2:** Time Frame for Controlling the Frequency [25].

Control	Timeframe
Activation Instant	0.7 to 1.3 s
Primary Control	10 to 60 s
Secondary Control	60 to 600 s
Tertiary Control	600 s to hours
Time Control	hours



**Figure 3.1:** How different frequency services restore a frequency drop in a power system [26]. *Note:* The categorized control time frames can be seen in Table 3.2 and the activation instant time does not consider for the support and recovery duration of FFR.

**Table 3.3:** Requirements of the different system services in Sweden [19].

Reserve	Bid size [MW]	Procurement	Activation [Hz]	Configuration
FCR-N	0.1	1-2 days before	+/- 0.1 Within 180 seconds	Symmetric
FCR-D	0.1	1-2 days before	Under 49.9 Within 30 seconds	Only up regulation
aFRR	5	Once a week	Resets FCR-N Within 120 seconds	Symmetric
mFRR	5/10	Operating hours	Purchase if needed Within 15 minutes	Symmetric

### 3.3 Frequency Capability of The Wind Turbine

Since WTs are generating power, with the same principle as other power plants, the service to provide ancillary services has always been available. However, since there have not been significant reasons for the Swedish power system to implement it, it has been expendable to an extent. Also to consider is that Sweden is dominated by hydro power plants and is working well to balance the frequency at present time and wind power systems was not always awaited as now. To note is that other countries with higher amount of wind penetration and lower hydro power resources has developed and integrated wind power more than Sweden. Moreover, because of the continuous increase of wind power plants, the question arises to what the possibilities are for providing frequency control services to the system [19].

The benefit of having wind power plants are mainly the rapid changes of power output the WTs can produce compared to, for instance, hydro power. This justifies wind power systems compatibility to specifically provide primary control services, which makes it essential for power systems with a higher share of intermittent generation. It is also compelling for wind power suppliers to have the feature of being able to provide a wide variety of frequency controls, which enables operation within all control schemes, see Table 3.2, [1, 6]. Since wind power systems have the capability to provide primary, secondary and tertiary services, the wind power systems versatility can adapt to other generating power plants. This enables the wind power systems to act as a potential frequency control support provider, which corresponds to a more faster and reliable balancing of the frequency in the system [19].

Since wind power is considered highly intermittent is down regulating, reducing production, more appropriate than up regulating, increasing production. This is mainly due to forecasting of the weather is imprecise and certain conditions have to be right for the wind power system to support to its full capability. Moreover, by up regulation the WT needs to be operating at a constantly lower output than capable, which wastes energy since wind power cannot be stored. Due to the possibilities of trading of electricity is it interesting for suppliers to address this matter if the financial conditions are met. Therefore is a collaboration of both the natural conditions and the economical aspects necessary to have, for a working symmetric regulation of the frequency [19].

# 4

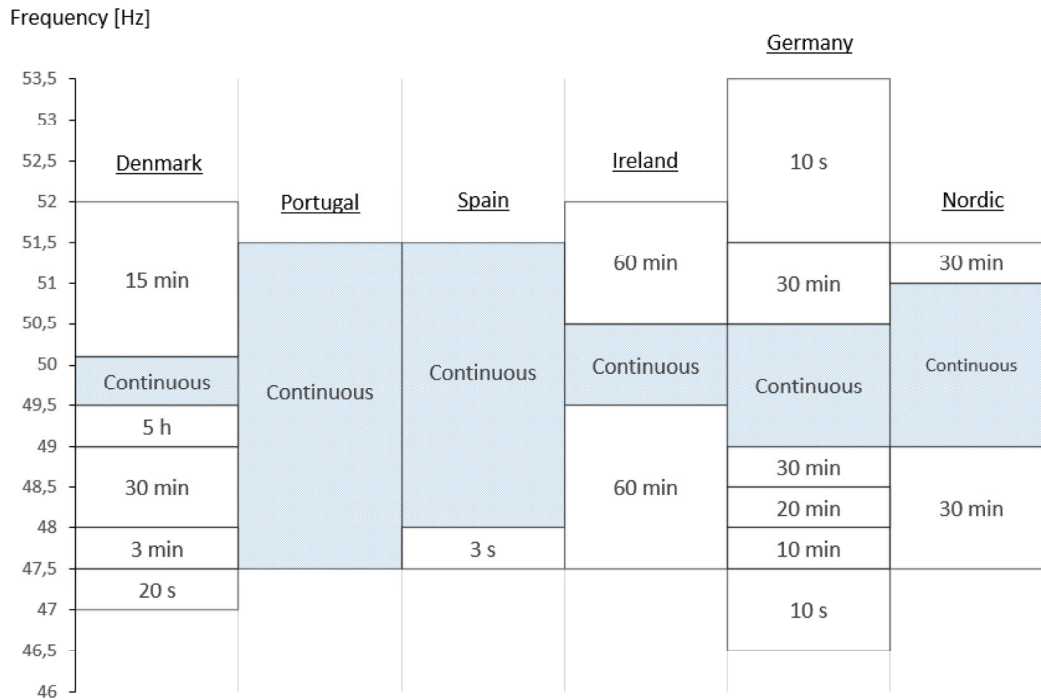
## International Overview and Experience

For international climate policy and European energy policy are different requirements and guidelines set and countries have to comply with the requirements as these guidelines and network codes takes precedence over domestic laws. However, individual countries can still enforce stricter regulations if deemed necessary [26].

Figure 4.1 illustrates how the different countries grid codes are detailed regarding the frequency deviations and how the prerequisites are set. The time frames illustrates how long the wind power generators have to stay connected to the grid and how the different countries enforces the generators to comply within the deviations. As seen from the graph, Denmark and Germany have a detailed grid code compared to Portugal and Spain where the turbines are continuously connected.

On these terms are Sweden's commission regulations already set and the legislation already established. This eases the coordination for different TSOs to act, and integration for the energy market for operation as more countries, services and products are integrated. Considering ancillary services in Sweden are rules for the operation of transmission and distribution grids issued via European Network of Transmission System Operators for Electricity (ENTSO-E) and Agency for the Cooperation of Energy Regulators (ACER) [6].

As a member of ENTSO-E is Sweden, SvK, cooperating with 42 different TSOs from 35 countries around Europe and is a part of a Nordic power system. ENTSO-E consist of five synchronous areas: the Nordic Area, the Baltic Area, the British Area, the Continental Europe Area and the Ireland and Northern Ireland Area. The Nordic power subsystem consists of the Nordic countries forming a synchronous area, where most ancillary system services are traded and operated under the same frequency [24]. Since, the countries are all part of different synchronous areas are different system services provided and traded. However, the functionality of the services is comparable and serves the same purpose and is classified into the different control schemes.



**Figure 4.1:** Requirements for different countries regarding the frequency deviation [26].

North America Electric Reliability Corporation (NERC) is the organisation that oversees and regulates the operation of transmission grids in North America. Likewise the ENTSOE-E are the corporation conducting and providing system services that are using different resources and the NERC Resources Subcommittee simplifies this by presenting a continuum for how the frequency services act in chronological order starting from primary, secondary, tertiary and lastly time control.

The table 4.1 illustrates how different system services are used and how they are compared to each other within different organisations for TSOs. Note that even though the Nordic area is issued via ENTSOE-E are they still using different system services than other ENTSOE-E synchronous areas.

**Table 4.1:** Terminologies with different provided services in power systems for balancing the frequency [19, 24, 25].

Nordic Power System	ENTSOE-E	NERC
FCR-N	FCR	Primary Reserve
FCR-D	FCR	Primary Reserve
aFRR/mFRR	FRR	Secondary Reserve/AGC control
aFRR/mFRR	RR	Tertiary Reserve

Countries with high level of wind penetration, mainly isolated grids, are actively implementing and developing different grid codes suitable for frequency regulation. The grid code is the electrical specification for how the technical standards and parameters should be implemented. Therefore, demonstrating grid code compliance are essential for establishing a grid that is functioning in a both secure and economical beneficial matter for all involved parts.

While each grid code contains different rules and standards see, [27, 28, 29], the principle is more or less the same for the countries providing ancillary services. The essential objectives and conditions are if possible, ensure that the grid codes works together and in practice for the benefit of TSO, power system, and users. Provide set of principles regarding the status and development while providing an outline for TSOs and regulatory authorities to collaborate with regard to grid codes.

For wind power plants are the participation in frequency regulation reflected by the grid code configurations and requirements. By means of the regulations and TSOs predetermined structure are the fundamentals varying for different countries. However, countries that are geographically adjacent are more likely to use similar grid code regulations.

For instance, the Irish grid code requires that new wind farms to have the capabilities to implement power curtailment. Furthermore, if frequency deviation occurs there are predetermined points for the layout of peculiar active power generation that are used as a function of the accessible power to compensate for the deviation. The Irish code also requires a minimum response rate of 1 % for the specific turbines rated power per second [30].

Moreover, Hydro-Quebec, a TSO in Canada requires that all new wind farms, rating of 10 MW or more, to have the capability to change the power output for a minimum of 10 seconds for frequency deviations of 0.5 Hz or more [31]. Eltra and Elkraft, TSOs for Denmark, requires wind farms connected to their grid to be able to trail the displaced power that is in reserve and record the system operators generated power level [32]. Red Electrica, TSOs for Spain, requires wind farms to be able to adjust the power output, with a specific requirement of the total rated power, in response to frequency deviations in the grid [33].

# 5

## Domestic Frequency Regulation

### 5.1 Introduction

In Sweden is SvK, an organisation owned by the government, responsible for the balance in the electrical system. They are the TSO in Sweden and are responsible for the short term balance between production and consumption throughout the country. They ensures that the power system is always in balance when operating and have delegated the power production and the financial responsibility to different independent entities exclusively with that function. The transactions are usually within the electricity producers and settled by the market operators.

According to the Swedish power system are the providers accountable for delivering the same amount of energy as the customers demand. This is mostly done by tracking a forecast to estimate the consumption and trading according to the power exchange in the Nord Pool market. The providers need to enter an agreement with SvK, to have the authority to balance the grid, either themselves or an authority that works with balancing.

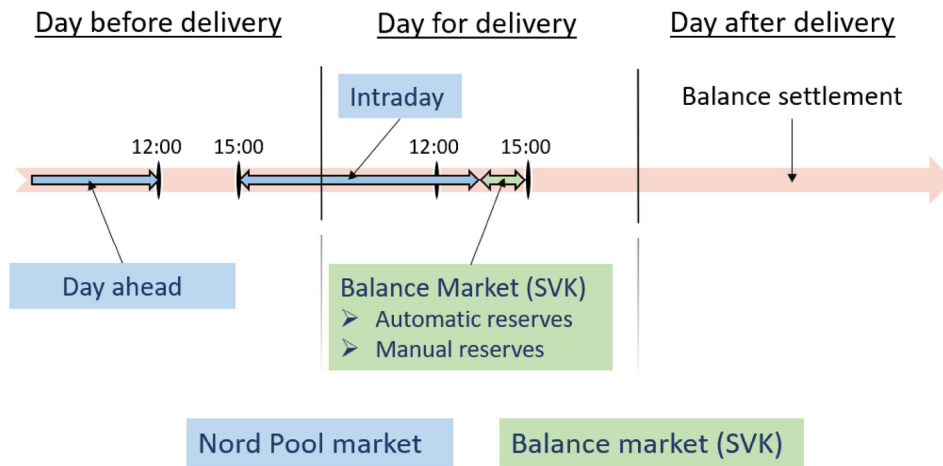
In the Swedish power system is the power system normally at a frequency of 50 Hz and very seldom deviates out of a range of 0.5 Hz [19]. As the system must be balanced in a short period of time, the different power plants need to collaborate since they have different properties, depending on type, size and location to restore the balance [1].

There are several control regimes to regulate the frequency to a equilibrium state. As there are different systems around the world with divergent management, the focus of this chapter will be on how the Swedish power system conduct to adjust the frequency of the system to a desirable condition.

### 5.2 Nord Pool

Nord Pool runs the leading power market in Europe and offers daily basis of market to help secure the necessary balance in the grid. It is a continuous market, where trading is taking place everyday until one hour before delivery and in some case last minutes as well. Nord Pool offers day-ahead and intraday markets to customers, where day-ahead is the main arena for trading for the coming day, and intraday market supplements for day-ahead, mainly for balancing between supply and demand. The market are provided by TSOs and are determined by the supply and demand of the energy and provides a wide set of orders for buyers and sellers The Figure 5.1 gives an overview of how the transactions of the wholesale market are

conducted and when the different markets are operating [34].



**Figure 5.1:** Overview of the activity of the balancing market [19].

The Balancing Service Providers (BSP) are market participants that provides ancillary services to the system operators and balance responsible party (BRP) are the electricity suppliers that are responsible for the demand and supply of production. The BRP especially trades within the Nord Pool and the transactions are traded along with forecasts in order to plan the balance during the day-ahead market. If the power demand or supply would somehow alter during the delivering day are the trades adjusted during the intraday.

For normal operation without disturbances are the frequency checked every minute in the transmission system. However, since BRPs rarely are precise, the role of SvK is to verify every hour by compensating, through the balance market, to ensure that it is in balance within that hour. If an unbalance occurs, the BRPs that are responsible will in return compensate SvK for the costs of restoring the frequency balance. This happens during the balance settlement [35].

Figure 5.2 shows the key concepts of how the Nordic power market is structured and how it is operating. Future market refers to financial contracts within the time span of 3-6 year, which are mainly used for price hedging and risk management. Elbas and Elspot are equivalent to intraday and day-ahead respectively.

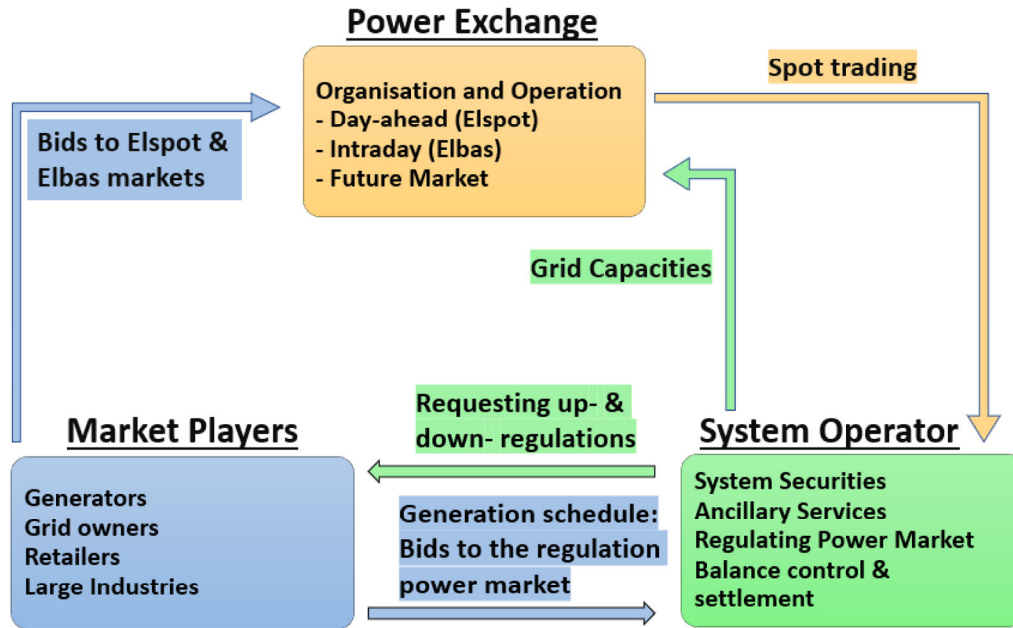


Figure 5.2: Overview of the market structure.

# 6

## Modelling and Simulation

### 6.1 Introduction and Overview

In this research an individual WT will be conducted. This is to simulate APC for the WT to have the capability to provide frequency control. A simplified model with a RL-circuit equivalent of an electric machine will be served as a platform for the WT. The relationship between  $C_p$  and TSR for this WT are as seen in Figure 2.8 with a rated power of 40 kW. However, in this case is the power specified in per units and scalable for the desired power output. The tests will consist of different cases where power curtailment will be conducted.

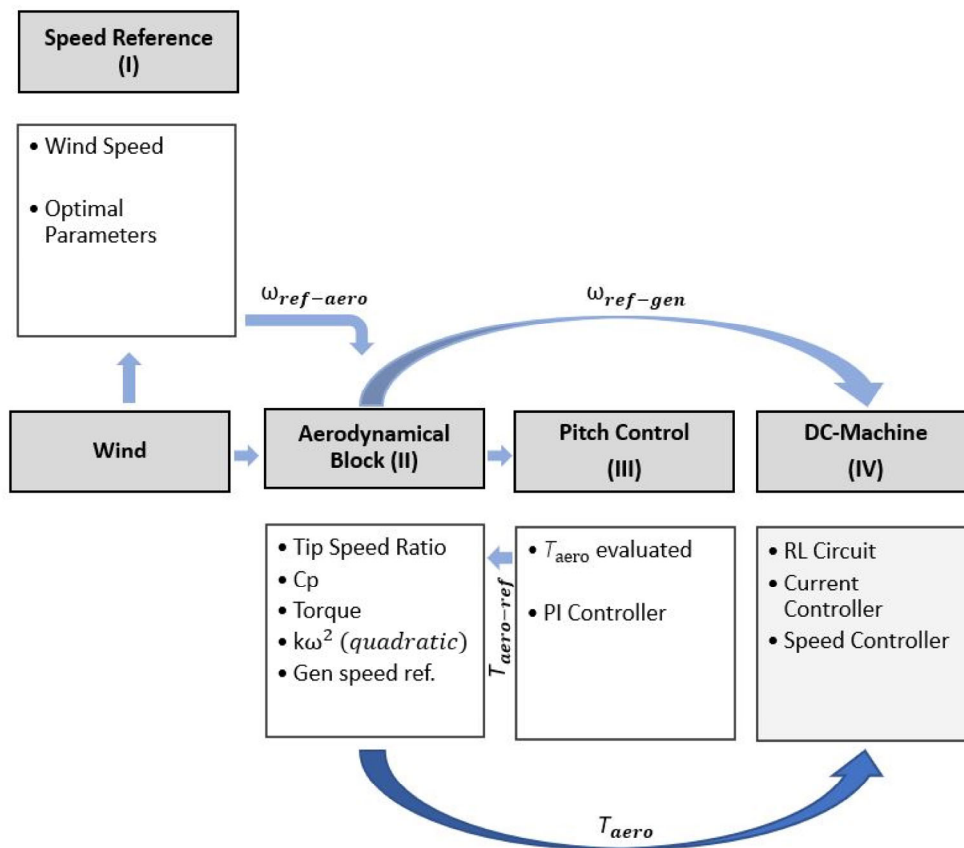
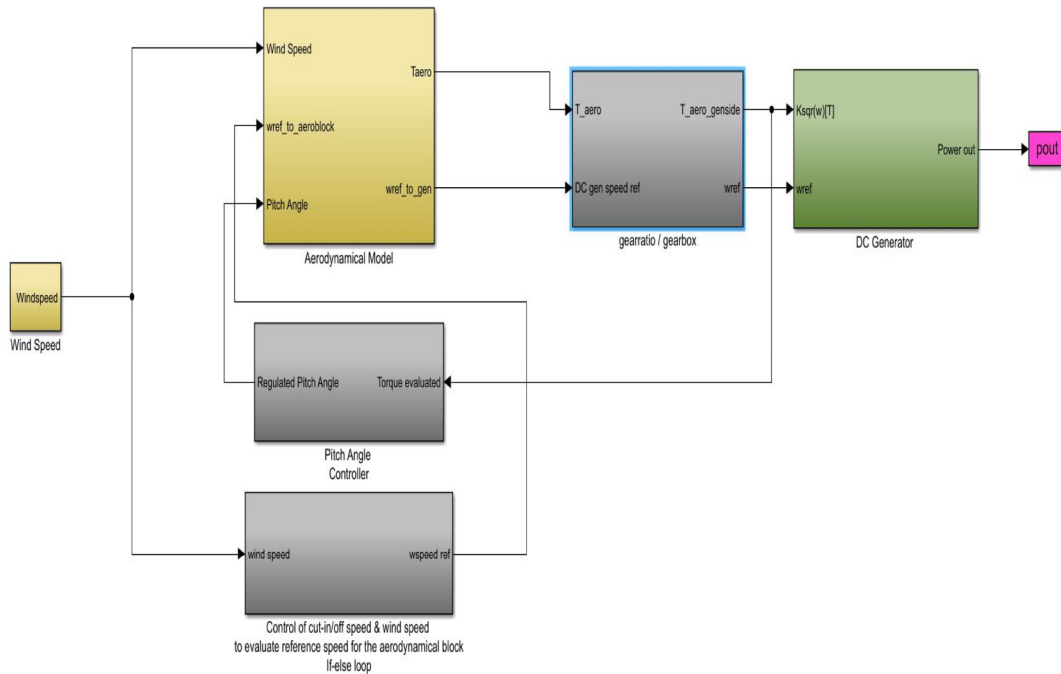


Figure 6.1: Overview of the simulation implemented in Simulink.

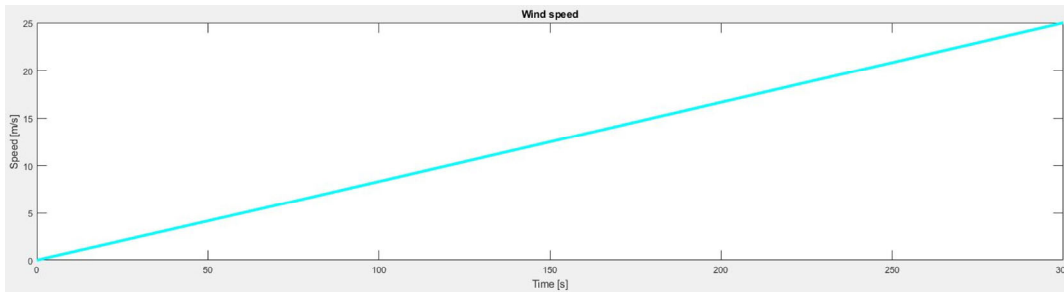
The simplified simulation of the WT is made up of four subsystem-blocks as seen in Figure 6.1. The first block (I) is where the optimal angular speed is computed with the wind speed as input. Furthermore, it is also used as an input for the aerodynamic block (II). In the second block (II) is the aerodynamic torque computed with the available wind power and the optimal angular speed as inputs. The aerodynamic block also provides a angular reference speed for the DC machine (IV). The third block (III) is where the pitch controller is designed. The pitch controller block (III) regulates the pitching angle needed for the desired output and sends it back to the second block (II). The fourth block (IV) is the DC machine that computes the power produced by initiating the reference angular speed and the torque from the aerodynamic block (II). An overview of the Simulink model can be seen in Figure 6.2.



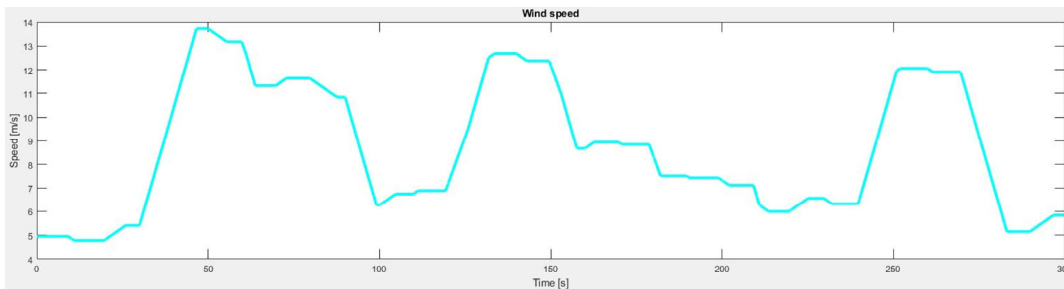
**Figure 6.2:** Overview of the system in Simulink.

### 6.1.1 Wind speed

The initial input for the model is the wind speed that is generated depending on the desired outcome. To display the functions of the different blocks, different scenarios were simulated to obtain the desired outputs for the respective subsystems. The generated wind speeds were divided into two different scenarios where the first wind speed simulation increases from 0 m/s to 25 m/s and the second one randomly generated wind speeds ranging from 4.5 m/s to 14.5 m/s. Both tests conducted were simulated for 5 minutes. Figure 6.3 and 6.4 present the two different scenarios and how the wind speed is changing against the time.

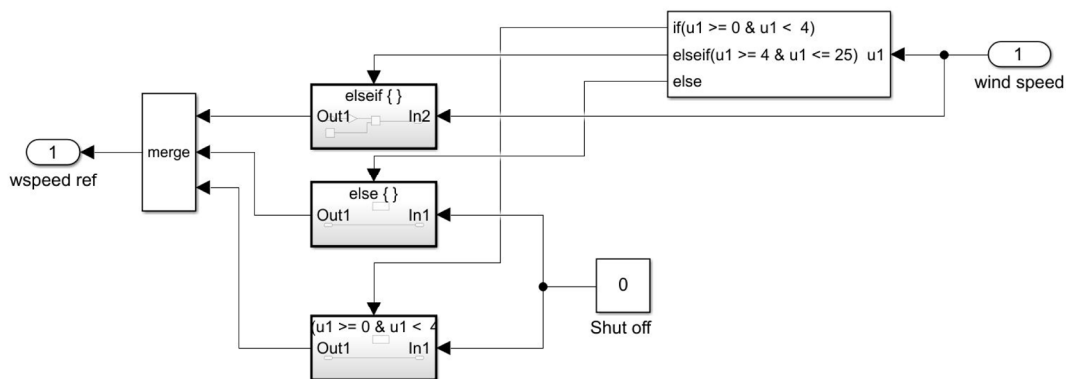


**Figure 6.3:** Wind speed simulation during five minutes with a wind speed ramping from 0 m/s to 25 m/s.



**Figure 6.4:** Wind speed simulation during five minutes with a randomly changing wind speed between 4.5 m/s to 14.5 m/s.

### 6.1.2 Reference Speed



**Figure 6.5:** The content of the reference speed block in Simulink.

The input for the reference speed block is the generated wind speed. The subsystem consists of an if-else loop, for different operation modes, which through the conditions set for the cut-in- and cut-off speed is providing different angular speeds to be used as a reference.

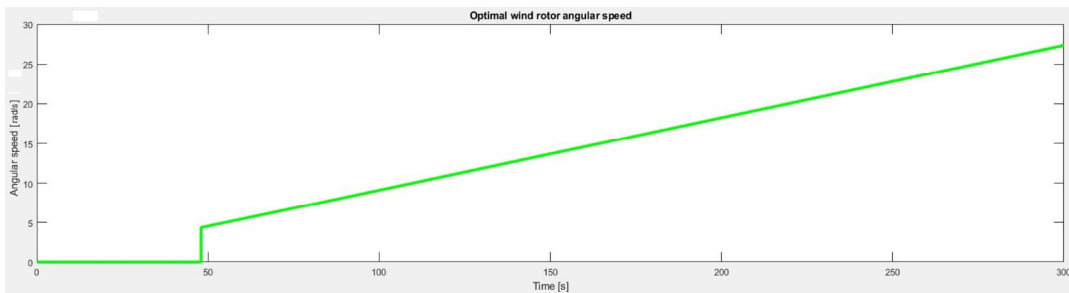
The conditions for the three different operation modes are:

- **Operation I:** wind speed is between 0-4 m/s.
- **Operation II:** wind speed is between 4-25 m/s.
- **Operation III:** wind speed is above 25 m/s.

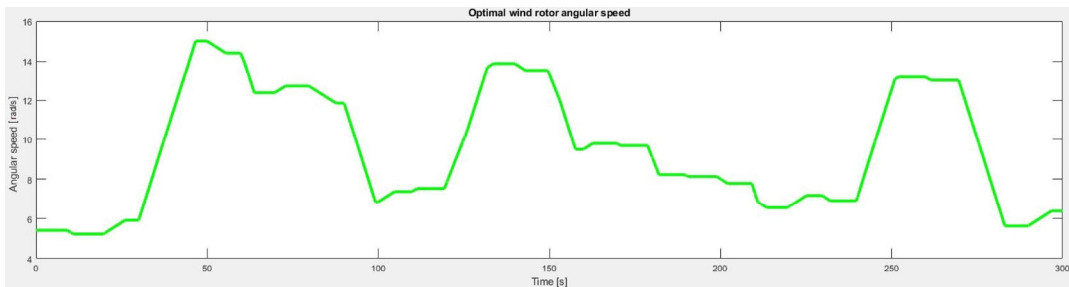
These three conditions could represent three different operation modes. The first operation mode (I) is where the cut-in speed is and for all wind speeds below 4 m/s is the WT halted. The same process occurs during operation mode (III) where the WT is halted due to the cut-off speed and gives a reference speed of zero when the wind speeds is over 25 m/s. During operation mode (II) is the reference speed computed by rearranging (2.1) to:

$$\omega_{r,opt} = \frac{\lambda_{opt} v_w}{R} \quad (6.1)$$

The computed reference speed is then transferred to the aerodynamic block. The following Figures 6.6 and 6.7 presents the simulation of the reference blocks output during the two wind speed scenarios without regulation of the reference speed.

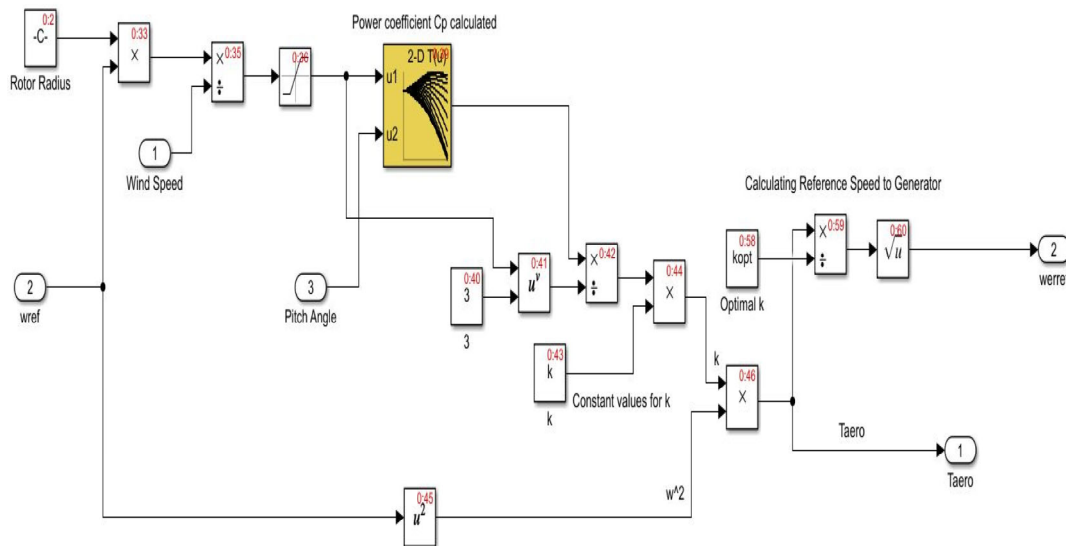


**Figure 6.6:** Angular speed as output from the speed reference block during a five minute simulation with a ramping wind speed from 0 to 25m/s.



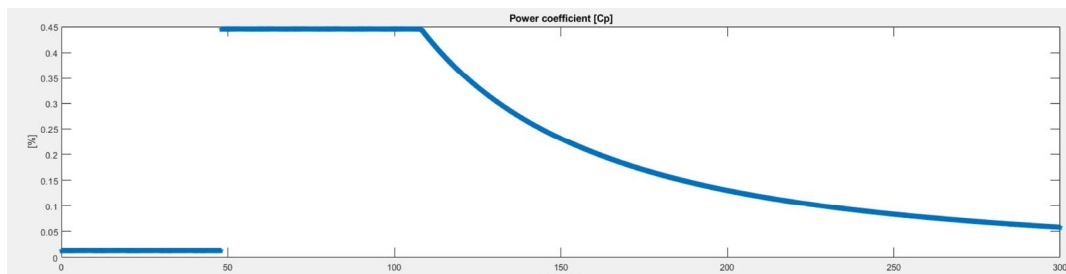
**Figure 6.7:** Angular speed as output from the speed reference block during a five minute simulation with a wind speed randomly changing between 4.5 m/s to 14.5m/s.

### 6.1.3 Aerodynamic Model



**Figure 6.8:** The content of the aerodynamical block in Simulink.

The inputs for the aerodynamic block is the reference angular speed from the reference speed block, the wind speed and the computed pitch angle from the pitch control block. The TSR is calculated by (2.5) and through a 2D lookup table which contains data of the correlation between TSR, pitch angle and  $C_p$  an approximate value of the  $C_p$  is obtained. The lookup table is used to find the interpolation from the pitch angle and the TSR to evaluate the  $C_p$ . The following Figures 6.9 and 6.10, presents the resulting  $C_p$  from the lookup tables output during the two scenarios. As seen in the figures, the maximum  $C_p$  is limited to 0.445. The WT reaches the rated power at the optimal wind speed of 9 m/s and as the wind speed increases  $C_p$  will decrease as the blade pitch angle increases to adjust the rotation speed to its limit.



**Figure 6.9:** Obtained  $C_p$  for the five minute simulation with a ramping wind speed from 0 to 25 m/s.



**Figure 6.10:** Obtained  $C_p$  for the five minute simulation with a randomly changing wind speed between 4.5 m/s to 14.5 m/s.

The torque generated by the rotor is defined by the following expression:

$$T = \frac{P}{\omega_r} \quad (6.2)$$

which can be rearranged together with (2.2) to the new following expression:

$$T = \frac{\rho A v^3}{2\omega_r} C_p \quad (6.3)$$

the wind speed rearranged from (2.1) equals to:

$$v_w = \frac{\omega_r R}{\lambda_{opt}} \quad (6.4)$$

and by rearranging (6.3) and (6.4), the maximum extracted torque can be expressed as:

$$T = \frac{\rho \pi R^5 \omega^2 C_{p,max}}{2\lambda_{opt}^3} \quad (6.5)$$

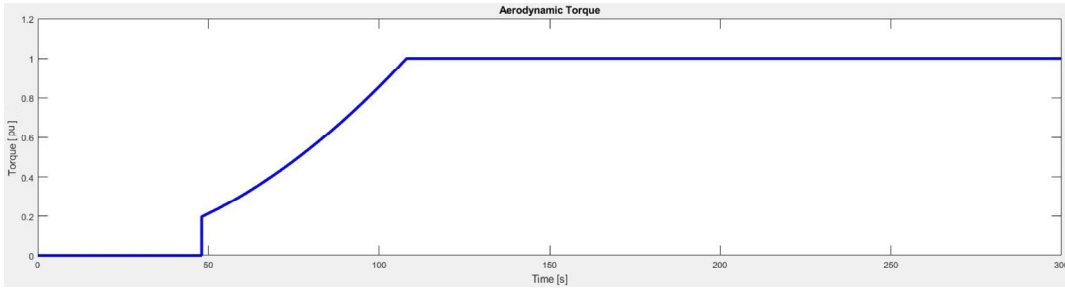
Since the torque from the WT has quadratic characteristics is the torque defined by:

$$T = k\omega_r^2 \quad (6.6)$$

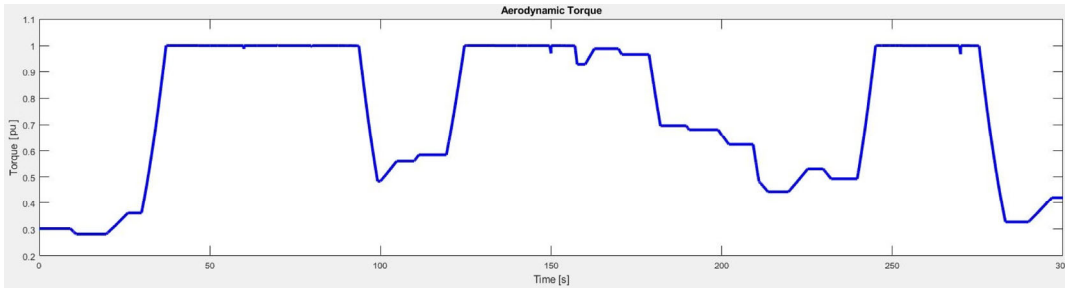
Combining the two previous mentioned equations (6.5) and (6.6) the constant k of the torque extracted by the WT is expressed as:

$$k = \frac{\rho \pi R^5}{2} \frac{C_{p,max}}{\lambda_{opt}^3} \quad (6.7)$$

The output from the aerodynamic block, during the two wind speed scenarios, is the torque which can be seen in Figure 6.11 and 6.12. From the figures shown are the torque throttled at the optimal speed and beyond by the pitch regulation. Moreover, as the torque is quadratic, the reference speed for the generator is constantly computed. This is done by dividing the generated torque by the constant coefficient k, with optimal parameters. This results to the current squared angular speed of the WT's rotor,  $w_r^2$ , which is converted into  $w_g$  through the gearbox subsystem, explained in Chapter 6.1.4. Figure 6.8 shows how the block was modelled in Simulink.



**Figure 6.11:** The aerodynamic torque simulated during five minutes with a wind speed ramping from 0 to 25 m/s.



**Figure 6.12:** The aerodynamic torque simulated during five minutes with a wind speed randomly changing between 4.5m/s to 14.5 m/s.

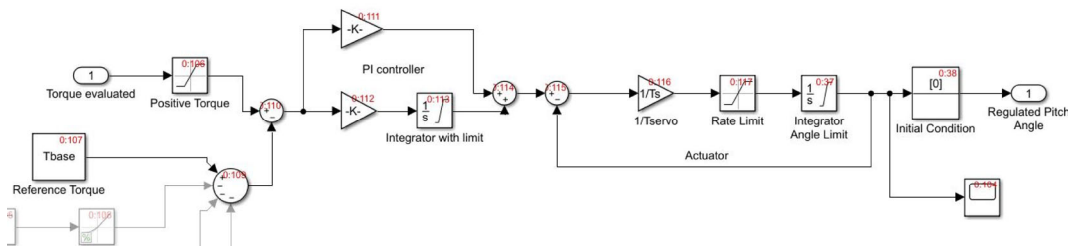
### 6.1.4 Gearbox

As the WT has a slower rotation of its rotor than the generator, it is necessary to have a gearbox to convert the rotation speed where the output speed of the gear box are inversely proportional to the ratio, between the rotor and generator. The gear box ratio is defined through the following equation:

$$N_{gear} = \frac{\omega_g}{\omega_r} \tag{6.8}$$

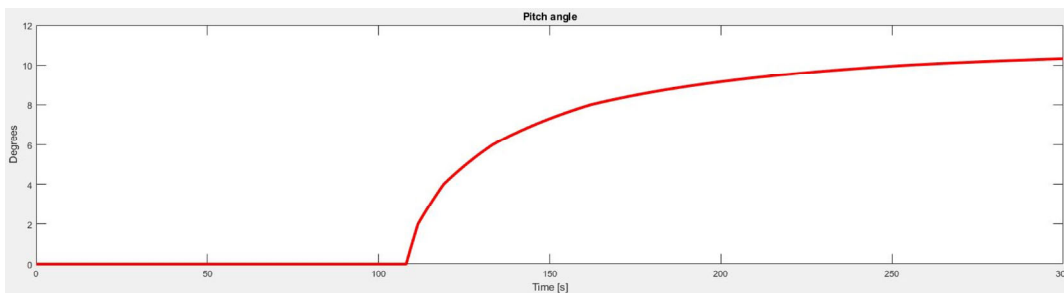
Moreover, the gearbox can be seen in Figure 6.2 between the aerodynamical- and the DC-machine block.

### 6.1.5 Pitch controller

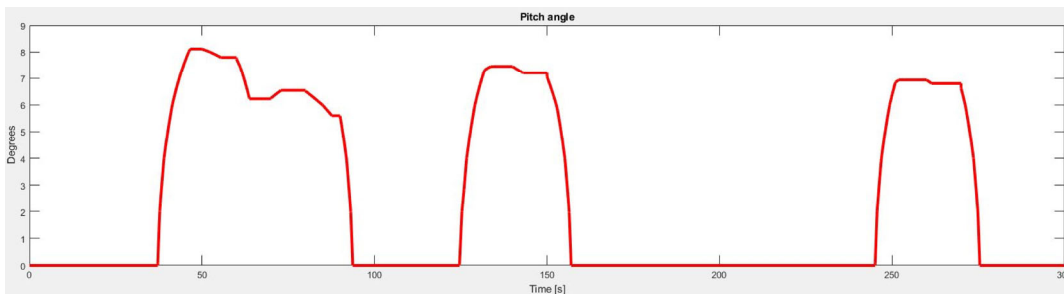


**Figure 6.13:** The content of the pitch controller block in Simulink.

As previously explained, pitching adjusts the torque which correspondingly changes the output power from the WT. This block contains a PI regulator which compares the base torque with the current torque. The base torque is calculated by using 6.2. The torque is chosen as a reference and referred from 6.6. Besides the PI regulator is a pitch actuator used to configure the necessary pitching angles to meet the desired requirements of operating at the referred torque. The actuator angle is between 0 to 40 degrees and the pitch rate of speed is limited for rate of change of the pitching angle. Figure 6.14 and 6.15 illustrates how the pitch regulator is adjusting the collective blade pitch to decrease the aerodynamic torque to match the reference torque. Furthermore, Figure 6.13 shows the pitch controller subsystem modelled in Simulink.



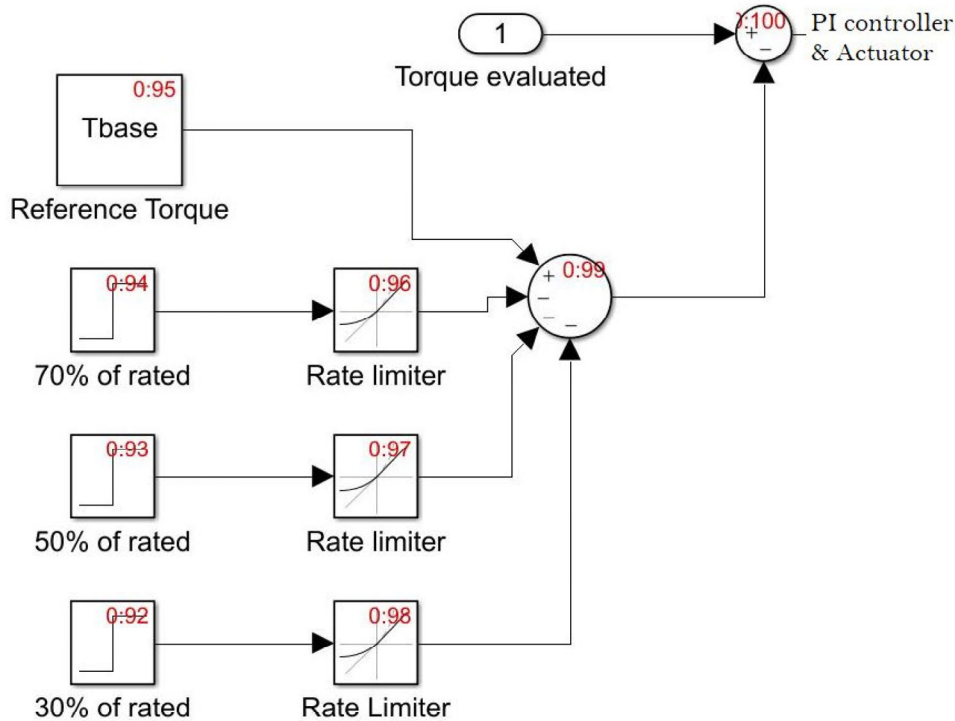
**Figure 6.14:** Pitch controller block simulated changing the collective blade pitch during five minutes with a wind speed ramping from 0 to 25 m/s.



**Figure 6.15:** Pitch controller block simulated changing the collective blade pitch during five minutes with a wind speed randomly changing between 4.5 m/s to 14.5 m/s.

### 6.1.6 Integrating of APC Through Pitch Controller

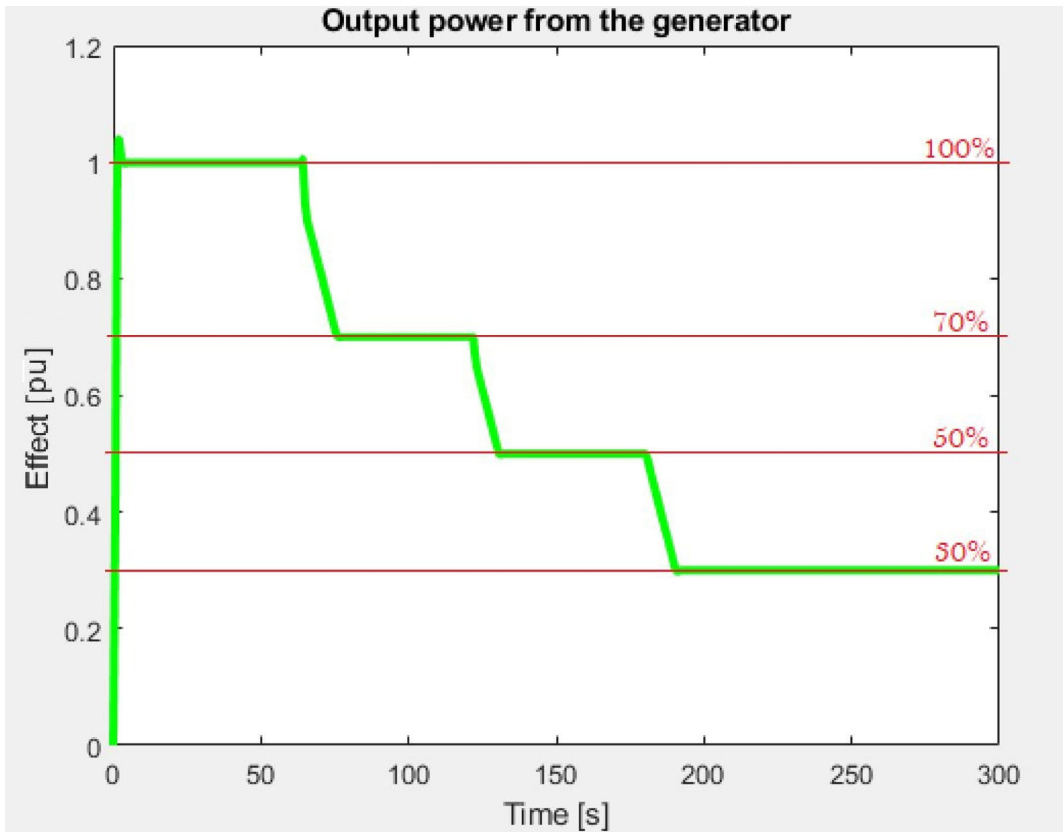
As the WT should be able to have APC capabilities, see Chapter 3.1, the torque percentage is simulated to imitate a control system where the torque is set based on the desired power curtailment. Figure 6.16 illustrates how the three different references are used as an reference for the pitch actuator to correspond to.



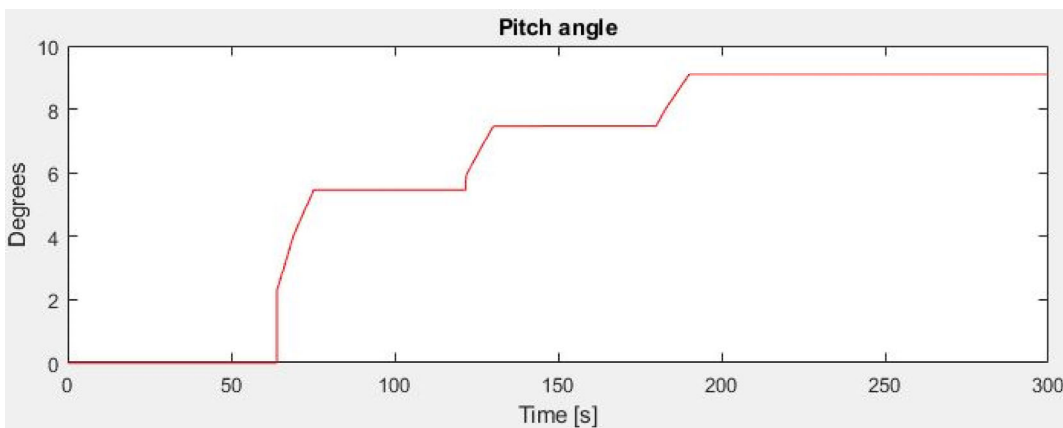
**Figure 6.16:** Modelling of controlling the power through the reference torque in the pitch controller block.

Since the torque is proportional to power as seen in (6.2) the steps are subtracting or adding the desired amount of torque that the controller should act upon as reference. To showcase of how the power curtailment worked in this chapter a constant speed of 9 m/s was generated and used. Figure 6.17 illustrates of how APC can be used and how the power is regulated to curtail every minute from 100%, 70%, 50% and 30% respectively. Figure 6.18 shows how the corresponding collective blade pitch increases to curtail the power output to the desired set value.

By power curtailment are the WT prepared to deliver or inject energy into the system when an agreement is made of delivering power. Therefore, depending on how the contracts or bids are arranged are the WT able to regulate the demanded power with pitch regulation method.



**Figure 6.17:** Simulation of a controlled power output during 5 minutes with a constant wind speed of 9 m/s.

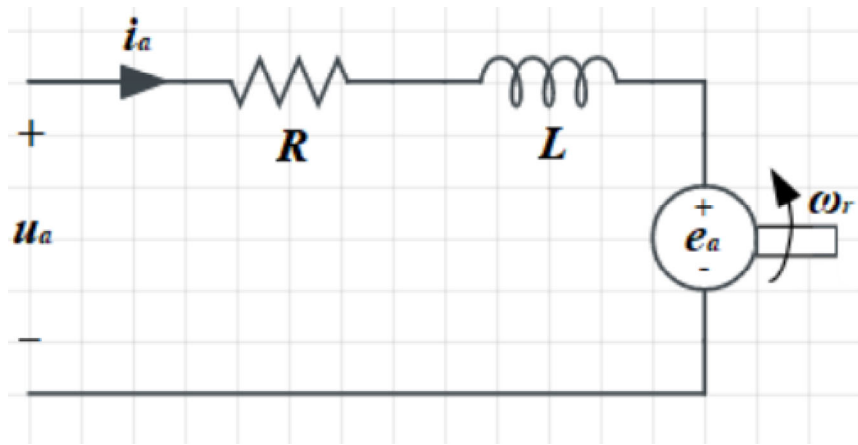


**Figure 6.18:** Simulation of pitch controller changing the pitch angle to limit the power with a constant wind speed of 9 m/s.

### 6.1.7 DC Machine

As mentioned earlier are the generated power from a dynamical modelling of an electrical machine. The modelling of the electric machine is a low pass filter, RL-circuit, which is a simplified equivalent circuit of an electric machine. By modelling the electrical equations, mechanical equations and the torque equations, coupling of the electrical system to the mechanical, the DC machine is controllable. The equivalent circuit can be seen in Figure 6.19. The equivalent circuit equation used for modelling the DC machine is defined as:

$$u_a = u_R + u_L + e_a \quad (6.9)$$



**Figure 6.19:** Equivalent circuit of DC machine.

where  $u_a$  is the armature voltage,  $u_R$  and  $u_L$ , the voltage over the resistor and the inductor respectively, and  $e_a$  the induced voltage, back-emf. This equation can be rewritten as:

$$u_a = R_a i_a + L_a \frac{di_a}{dt} + \omega_g \Psi \quad (6.10)$$

where  $R_a$  is the armature resistance,  $L_a$  the armature inductance,  $i_a$  the armature current,  $\Psi$  the flux linkage and  $\omega_g$  the generator speed. Moreover, the speed equation of the DC machine is defined as:

$$J \frac{d\omega_g}{dt} = T_e - T_L \quad (6.11)$$

where  $T_e$  and  $T_L$  represents the electrical and mechanical torque respectively and  $J$  the rotor inertia, which in turns can be rewritten as:

$$T_L = T_e - J \frac{d\omega_g}{dt} \quad (6.12)$$

the electromagnetic torque is thereby expressed as:

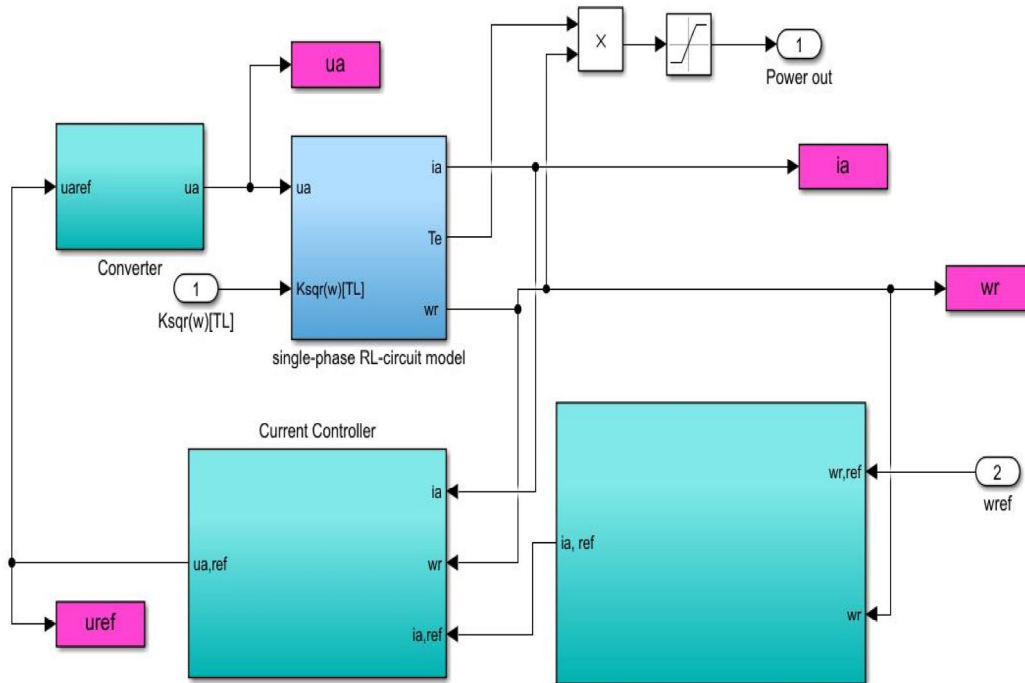
$$T_e = \Psi i_a \quad (6.13)$$

The electrical system of the RL-circuit is coupled with the extracted torque from the aerodynamic block that, in this case, served as an mechanical torque input,  $T_L$  as derived from (6.6). The model of the drive train modelled in this simulation is chosen to a simplified one-lumped mass model. This results in a equivalent rotational inertia of the generator which is derived as:

$$J_{eq} = J_g + \frac{J_w}{n_g^2} \quad (6.14)$$

The derived equivalent inertia is therefore replacing  $J$  in (6.12). Whereas  $J_g$  is the generator inertia,  $J_w$  the rotor rotational inertia of the WT and  $n_g$  the gear ratio from the gearbox.

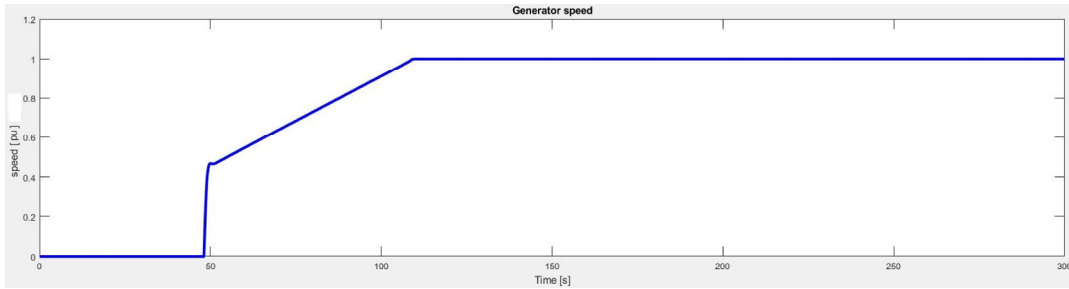
Additionally, as there is not a Maximum Power Point Tracking (MPPT) table available for the WT, it is necessary to control the current, voltage and speed of the generator. This is to ensure the right amount of power is generated within plausible speed, current and voltage. This is done by modelling a speed controller with a reference speed, which is compared to the current generator speed. The regulator used for the speed and current controller for the DC machine is a PI controller. Figure 6.20 - 6.23 shows how the blocks were modelled in Simulink for respective subsystem.



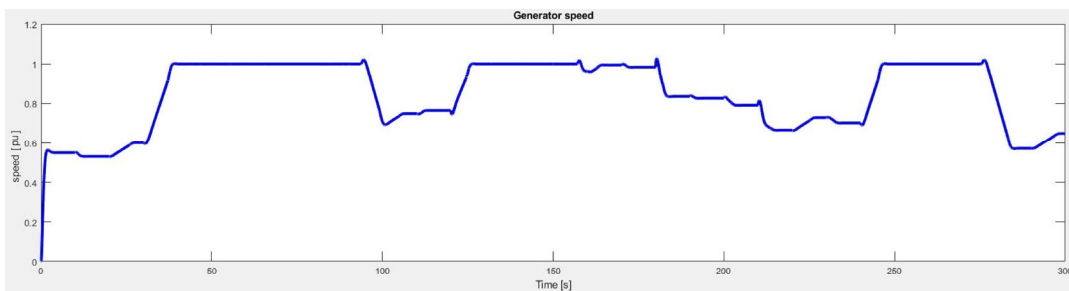
**Figure 6.20:** The content of the DC machine block in Simulink.



Figure 6.24 and 6.25 illustrates the rotational speed of the generator for the different cases. The rated speed of the generator, 1500 RPM, is reached when the wind speed is equal to and above 9 m/s. Since the torque is adjusted accordingly by the pitch controller are the torque limited and correspondingly for the speed of the generator that adjusts to the rated speed.

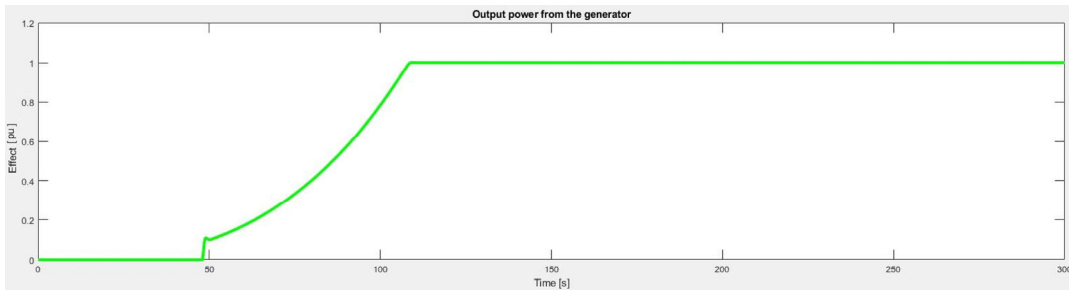


**Figure 6.24:** The rotational speed of the generator, with a rated speed of 1500 RPM, simulated during five minutes with a wind speed ramping from 0 to 25 m/s.

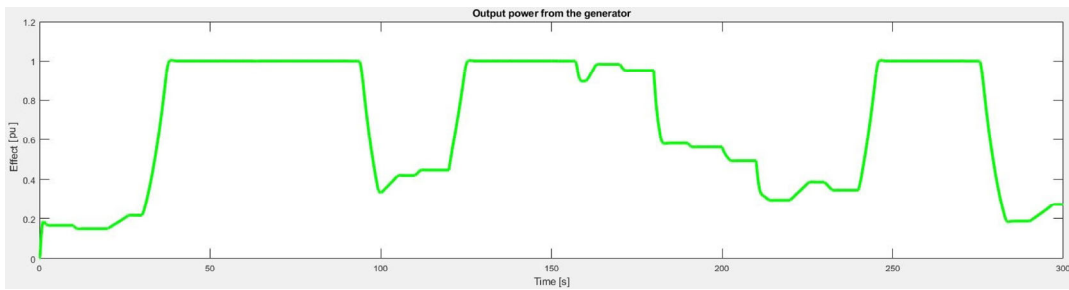


**Figure 6.25:** The rotational speed of the generator, with a rated speed of 1500 RPM, simulated during five minutes with a wind speed changing randomly between 4.5m/s to 14.5m/s.

Moreover, Figure 6.26 and 6.27 illustrates the generated power from the generator.



**Figure 6.26:** Simulation of the generators power output during five minutes with a wind speed ramping from 0 to 25 m/s.



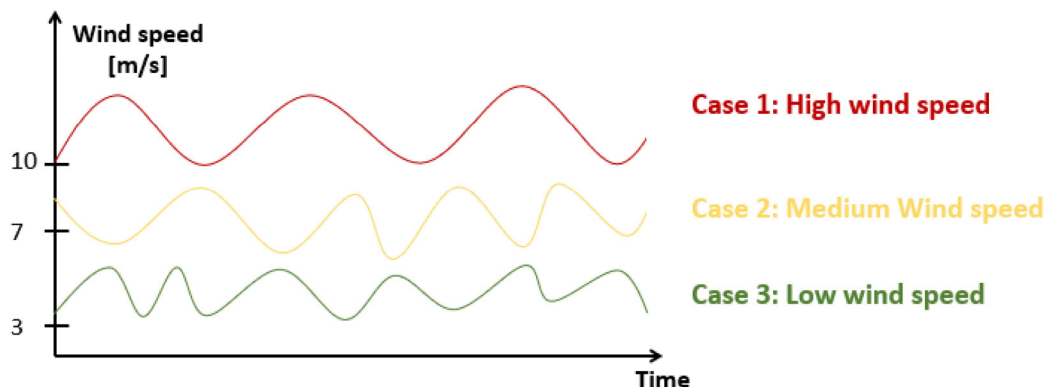
**Figure 6.27:** Simulation of the generators power output during five minutes with a wind speed changing randomly between 4.5 m/s to 14.5 m/s.

## 6.2 Case overview

Since the setup of the simulation is proportional, the calculations in the following simulations are set to represent a 30 MW WT. Additionally, the simulation will be carried out for 24 hours, between 00.00 - 23.00. To emulate simulations of different events the following simulations will cover different wind speed scenarios. The first three scenarios, see Figure 6.28, are fictionally generated as low-, mid- and high-speed:

- Case 1: Low speed : 3.1-6.6 m/s
- Case 2: Mid Speed : 6-9 m/s
- Case 3: High Speed : 10-15 m/s

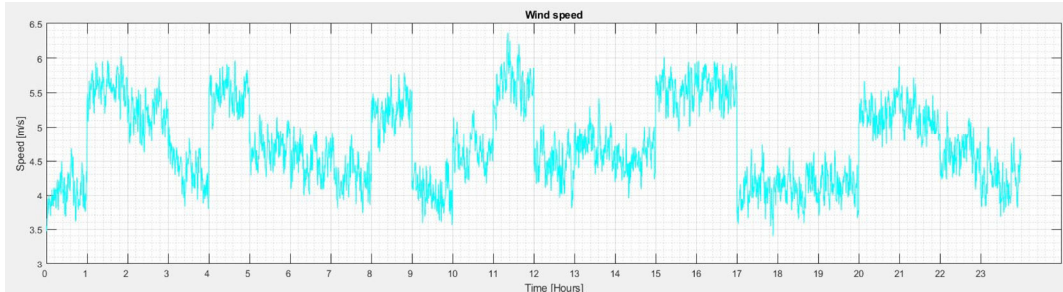
The simulations will be carried out with and without APC. If the given wind conditions are right, the power will be curtailed from a range of 70% to 10%. These varying settings were chosen to make it possible to analyze on how the bid size, amount of MW, of a WT can differentiate depending on the generated curtailed power. Also, as the wind speed varies it is also possible to find the wind powers capability to provide frequency control.



**Figure 6.28:** Visualization of the different cases corresponding to the different wind speeds. *Note: Graph is fictive and present a better visualization for ease the understanding of cases.*

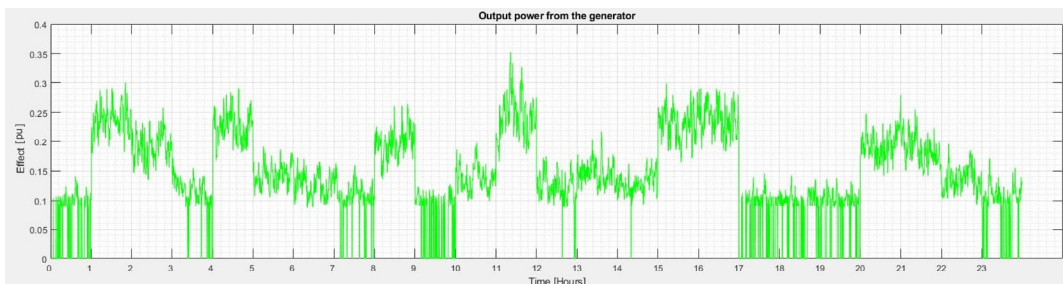
### 6.2.1 Case 1: Low Wind Speed

The generated wind speed representing a low speed scenario with a ranging wind speed between 3.1-6.6 m/s is presented in Figure 6.29.



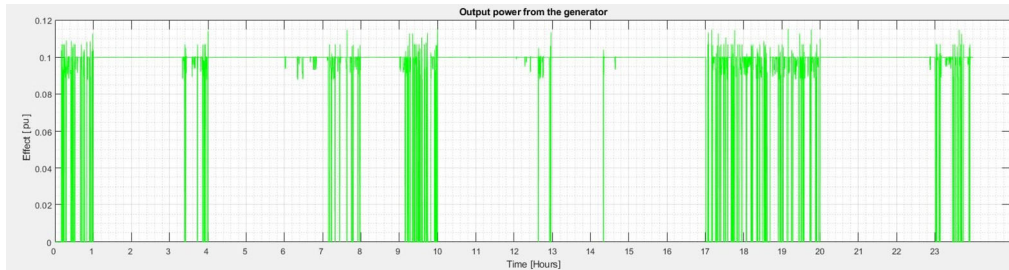
**Figure 6.29:** Wind speed variation between 3.1 to 6.6 m/s for a sample duration of 24 hours.

Following Figure 6.30 shows that the generated output power is only reaching up to approximately 0.3 power p.u. Due to the low wind speeds are the turbine halted when it is within operating region 1. Since the turbine does not reach rated speed or rated power is the pitch angle held constantly at zero to ensure the maximum amount of output power.

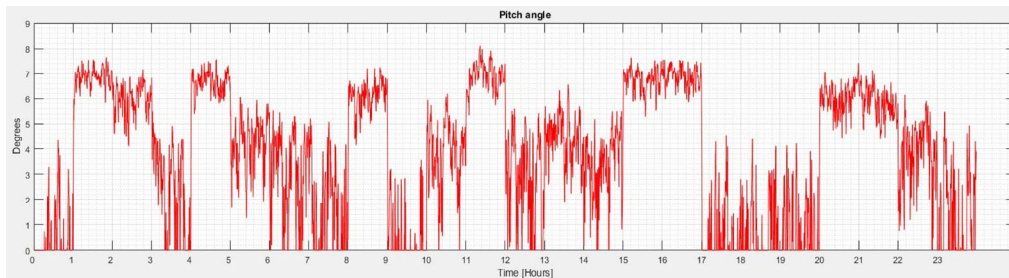


**Figure 6.30:** Output power during low speed scenario operating at normal operation.

**Power curtailment at 10% of rated power:** For Figure 6.31 is the power curtailed to 10% of the rated power, between the time 00.00 - 23.00. Figure 6.32 illustrates the pitch angle during this operation.



**Figure 6.31:** Output power between 00.00-23.00 during low speed scenario operating with power curtailment at 10% of the rated power.

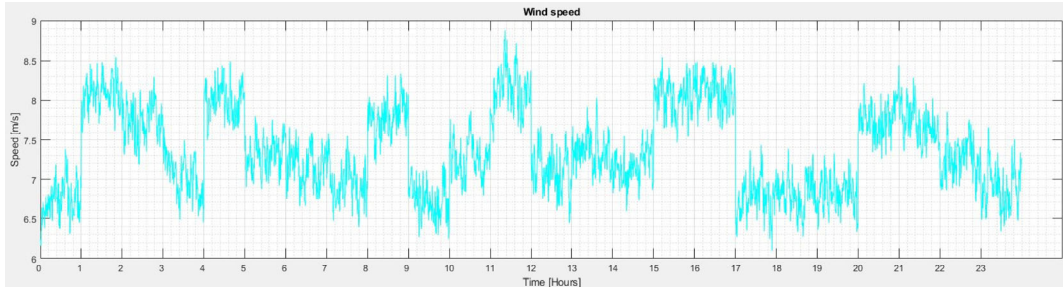


**Figure 6.32:** Pitch angle between 00.00-23.00 during low speed scenario operating with power curtailment at 10% of the rated power.

The fluctuation above the desired power curtailment are due to the pitch controller trying to regulate when the wind speed provides the torque that edges the new reference torque that keeps the power constant at 0.1 p.u. Since low wind speeds does not have enough wind penetration is the power curtailed only at 10%.

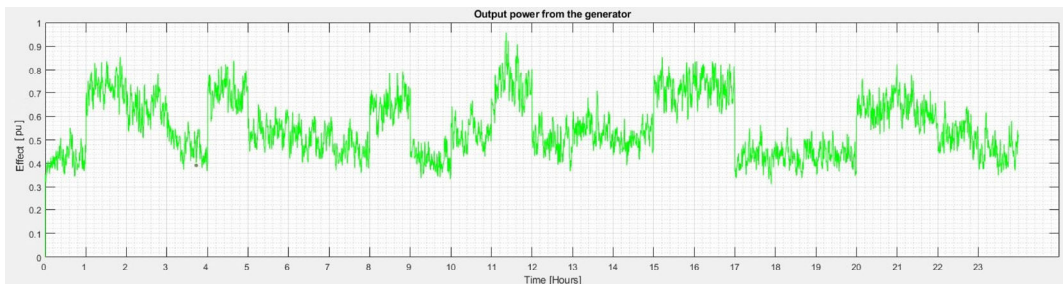
### 6.2.2 Case 2: Medium Wind Speed

The generated wind speed representing a mid speed scenario with a ranging wind speed between 6-9 m/s is presented in Figure 6.33.



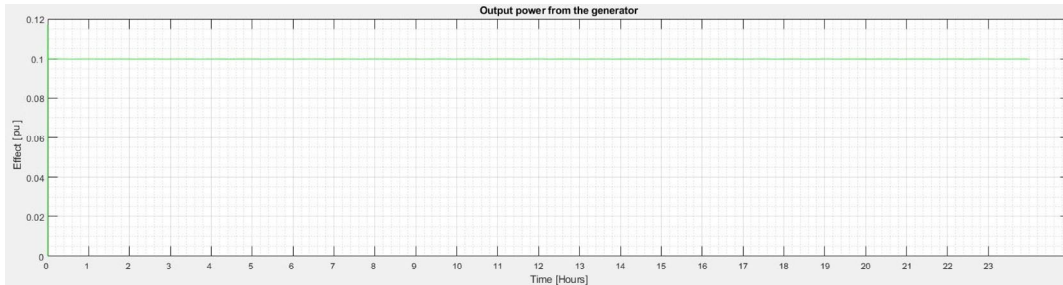
**Figure 6.33:** Wind speed variation between 6 to 9 m/s for a sample duration of 24 hours.

Following Figure 6.34 shows that the generated output power is reaching almost the rated power at 0.95 p.u when operating at normal operation. Since the rated wind speed is not reached is the the power coefficient,  $C_p$ , optimal and the pitch angle held at zero throughout the simulation, this operation refers to operation region zone 2, see Chapter 2.5.

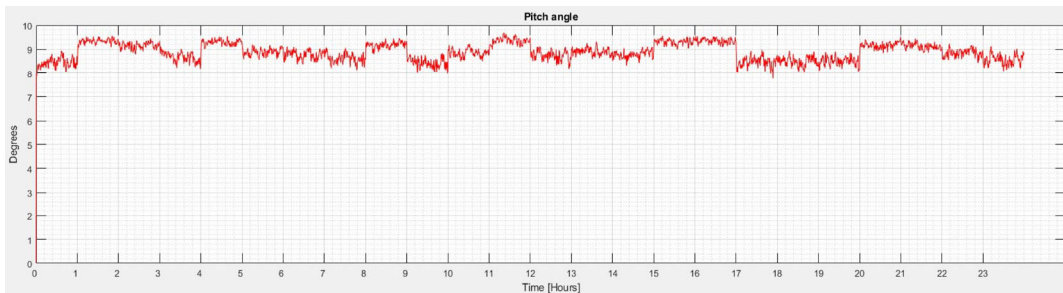


**Figure 6.34:** Output power during mid speed scenario operating at normal operation.

**Power curtailment at 10% of the rated power:** For Figure 6.35 is the power curtailed to 10% of the rated power, between the time 00.00 - 23.00. Figure 6.36 illustrates the pitch angle during this operation.

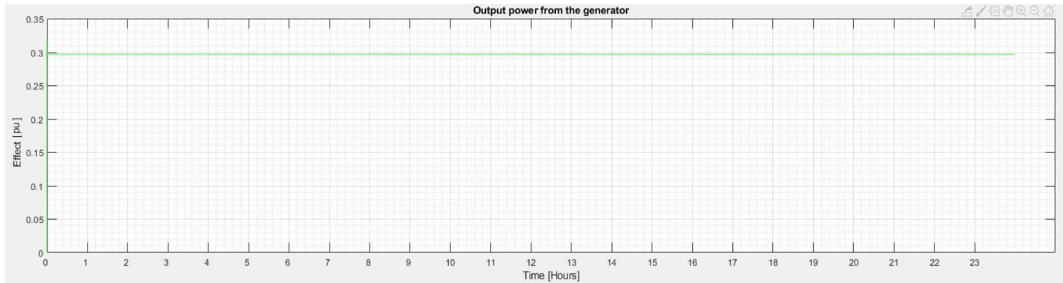


**Figure 6.35:** Output power between 00.00-23.00 during mid speed scenario operating with power curtailment at 10% of the rated power.

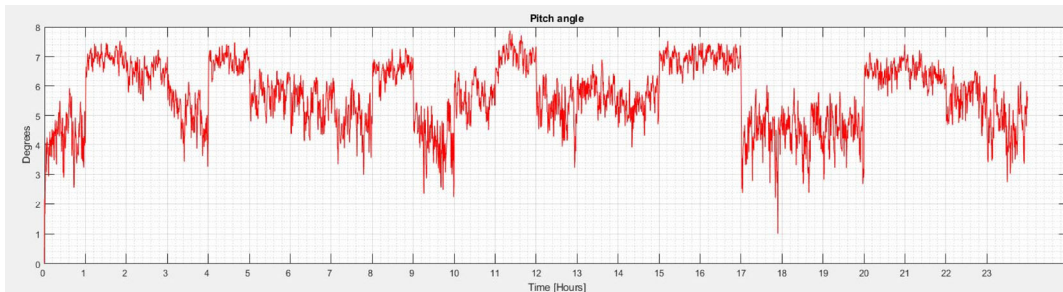


**Figure 6.36:** Pitch angle between 00.00-23.00 during mid speed scenario operating with power curtailment at 10% of the rated power.

**Power curtailment at 30% of the rated power:** For Figure 6.37 is the power controlled to 30% of the rated power, between the time 00.00 - 23.00. Figure 6.38 illustrates the pitch angle during this operation.

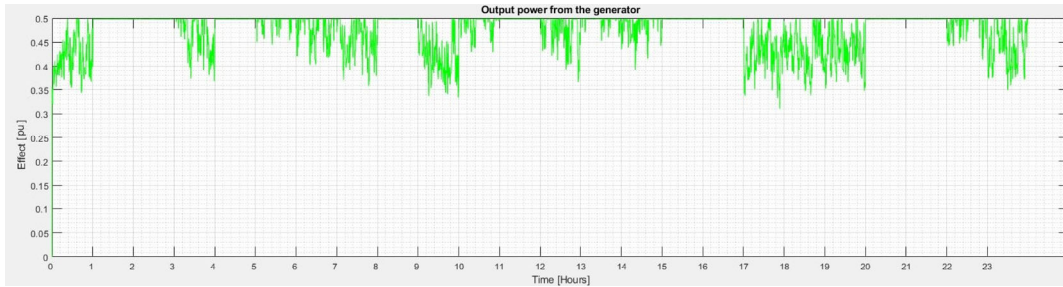


**Figure 6.37:** Output power between 00.00-23.00 during mid speed scenario operating with power curtailment at 30% of the rated power.

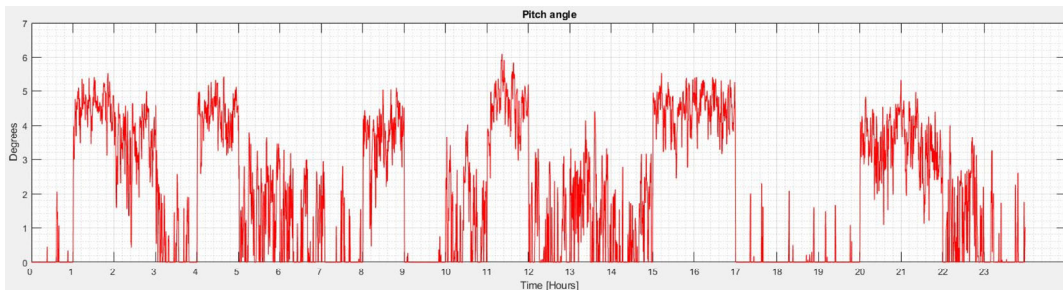


**Figure 6.38:** Pitch angle between time 00.00-23.00 during mid speed scenario operating with power curtailment at 30% of the rated power.

**Power curtailment at 50% of the rated power:** For Figure 6.39 is the power controlled to 50% of rated power, between the time 00.00 - 23.00. Figure 6.40 illustrates the pitch angle during this operation.



**Figure 6.39:** Output power between 00.00-23.00 during mid speed scenario operating with power curtailment at 50% of the rated power.

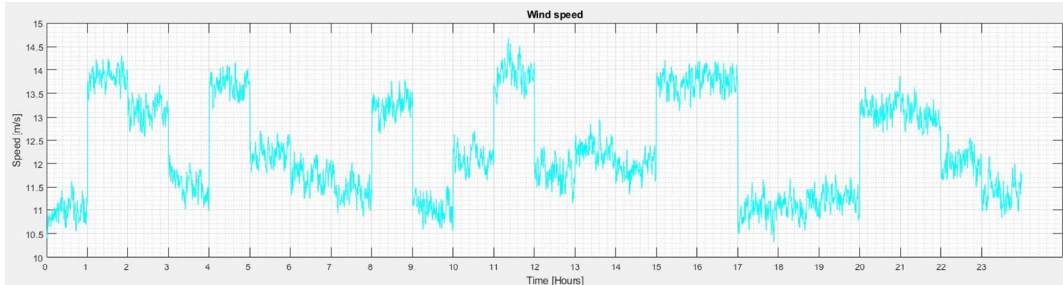


**Figure 6.40:** Pitch angle between time 00.00-23.00 during mid speed scenario operating with power curtailment at 50% of the rated power.

Since the wind conditions are not right is the output power not stable at the desired 50% output power during normal operation. Furthermore, it is not feasible to curtail the power to 70 % of the rated power.

### 6.2.3 Case 3: High Wind Speed

The generated wind speed representing a high speed scenario with a ranging wind speed between 10-15 m/s is presented in Figure 6.41.



**Figure 6.41:** Wind speed variation between 10 to 15 m/s for a sample duration of 24 hours.

Following Figure 6.42 shows that the output power is at 1 p.u during normal operation. This is due to the high wind speed penetration, thus, the turbine is operating at rated power. This means that the output power is limited and pitch controller is continually regulating the pitch angle.



**Figure 6.42:** Output power during mid speed scenario operating at normal operation.

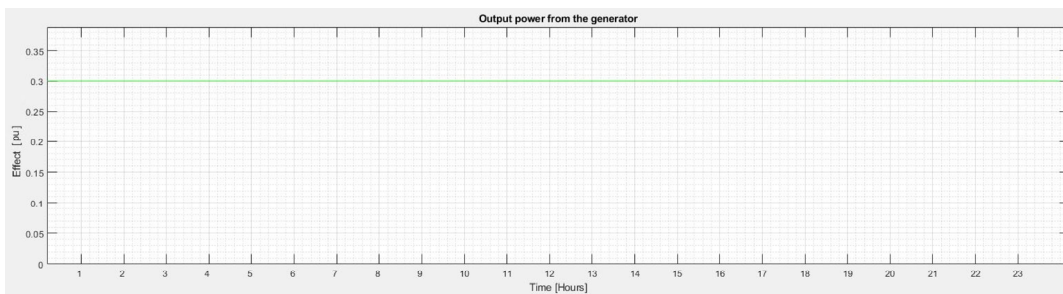
As the generating power during the high wind speed scenario is steadily operating with a rated power production of 1 p.u, are all cases are eligible as there are enough wind penetration.

**Power curtailment at 10% of rated power:** For Figure 6.43 is the power controlled to 10% of rated power, between the time 00.00 - 23.00.



**Figure 6.43:** Output power between 00.00-23.00 during high speed scenario operating with power curtailment at 10% of rated power.

**Power curtailment at 30% of rated power:** For Figure 6.44 is the power controlled to 30% of rated power, between the time 00.00 - 23.00.



**Figure 6.44:** Output power between 00.00-23.00 during high speed scenario operating with power curtailment at 30% of rated power.

**Power curtailment at 50% of rated power:** For Figure 6.45 is the power controlled to 50% of rated power, between the time 00.00 - 23.00.



**Figure 6.45:** Output power between 00.00-23.00 during high speed scenario operating with power curtailment at 50% of rated power.

**Power curtailment at 70% of rated power:** For Figure 6.46 is the power controlled to 70% of rated power, between the time 00.00 - 23.00.



**Figure 6.46:** Output power between 00.00-23.00 during high speed scenario operating with power curtailment at 70% of rated power.

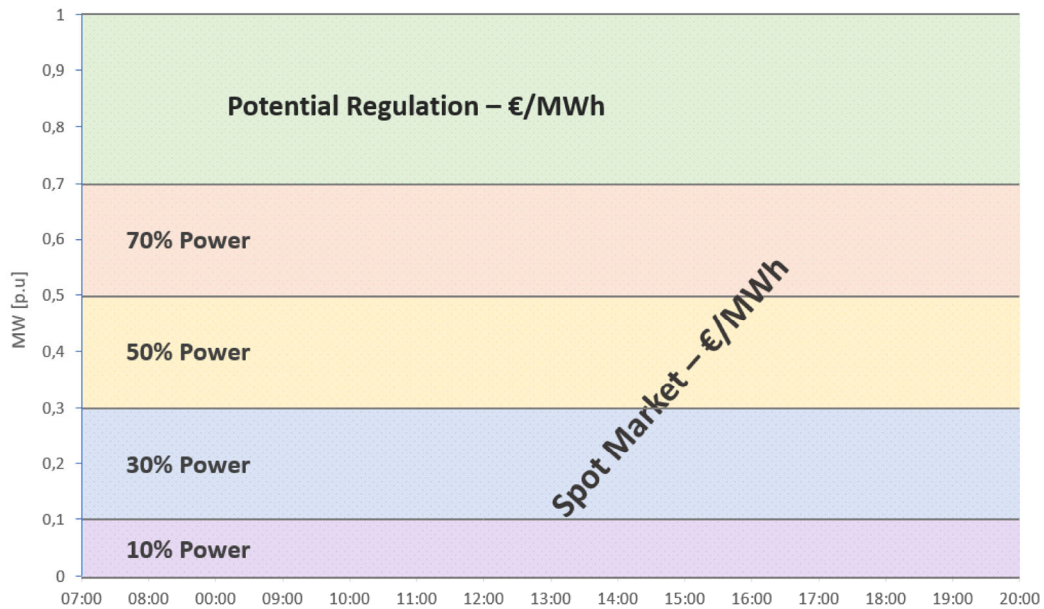
# 7

## Analytic Market Pricing

At present time are all wind power transactions operating through the day-ahead market and no frequency services are provided by wind power in Sweden [19]. If wind power providers should consider spilling energy, since wind energy can not be stored, should the tariffs be more attractive than the provision of energy. The market for ancillary services are complex and a lot of factors decides the market, such as: pricing, payments, charges, deployment and resource participation [36].

The charges are usually differently categorised depending on which services that are provided, see Table 3.2. Since the cases are simulating spinning reserves (operating at less than maximum output), the results from the simulation are classified as primary control services. Considering the requirements of a Swedish power system are FCR-N and FCR-D the most likely frequency services that will be offered from a WT. Hence, a fair market evaluation of both FCR services is going to be conducted, where a tendering process method is conducted, likewise, of how the day-ahead market is operating.

Figure 7.1 shows a simplified hypothetical example of how to evaluate a fair price within the market and how providers could be compensated by providing power regulation. Furthermore, from the simulation, the excess power after power curtailment is equivalent to the available power for FCR products. By using this concept an equilibrium state can be found where the bid prices intersect the spot prices, where potential regulation compensates for forgoing the energy market.

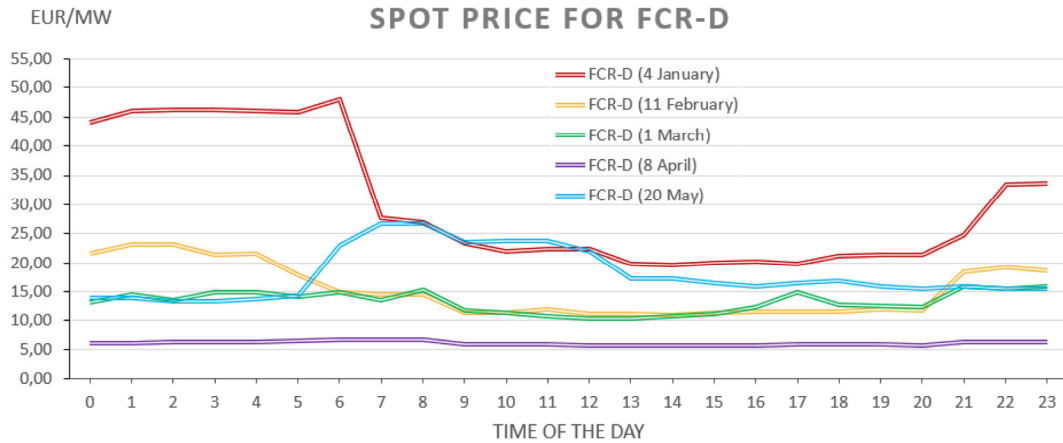


**Figure 7.1:** The different levels of power curtailment for a WT and the potential up regulation.

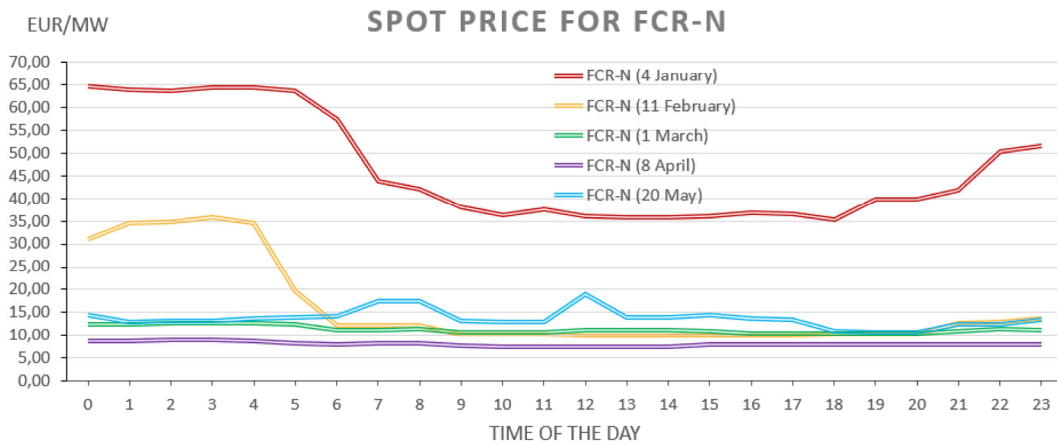
The market situation in Sweden is subdivided into four different region zones, where different volatile spot prices are traded in respective zone. Since the energy prices differs from one price area to another, and changes minute by minute it is difficult to estimate prices beforehand. The pricing of the ancillary service costs depends strongly on the underlying price costs of the generation and transmissions, and are tightly based on the inequality constraint. Therefore, if the cost based pricing for the suppliers are going to be profitable should the tariffs compensate for the bid-in cost as well as the lost opportunity from forgoing the energy market.

## 7.1 Spot Market Price

Since Sweden is divided into four different region zones are the four zones evaluated and compared to the current FCR prices available. All spot prices are taken from Mimer [37] and refer to A.1-A.5 for more detailed prices. The following graphs illustrates the prices for the different days, services and zones.

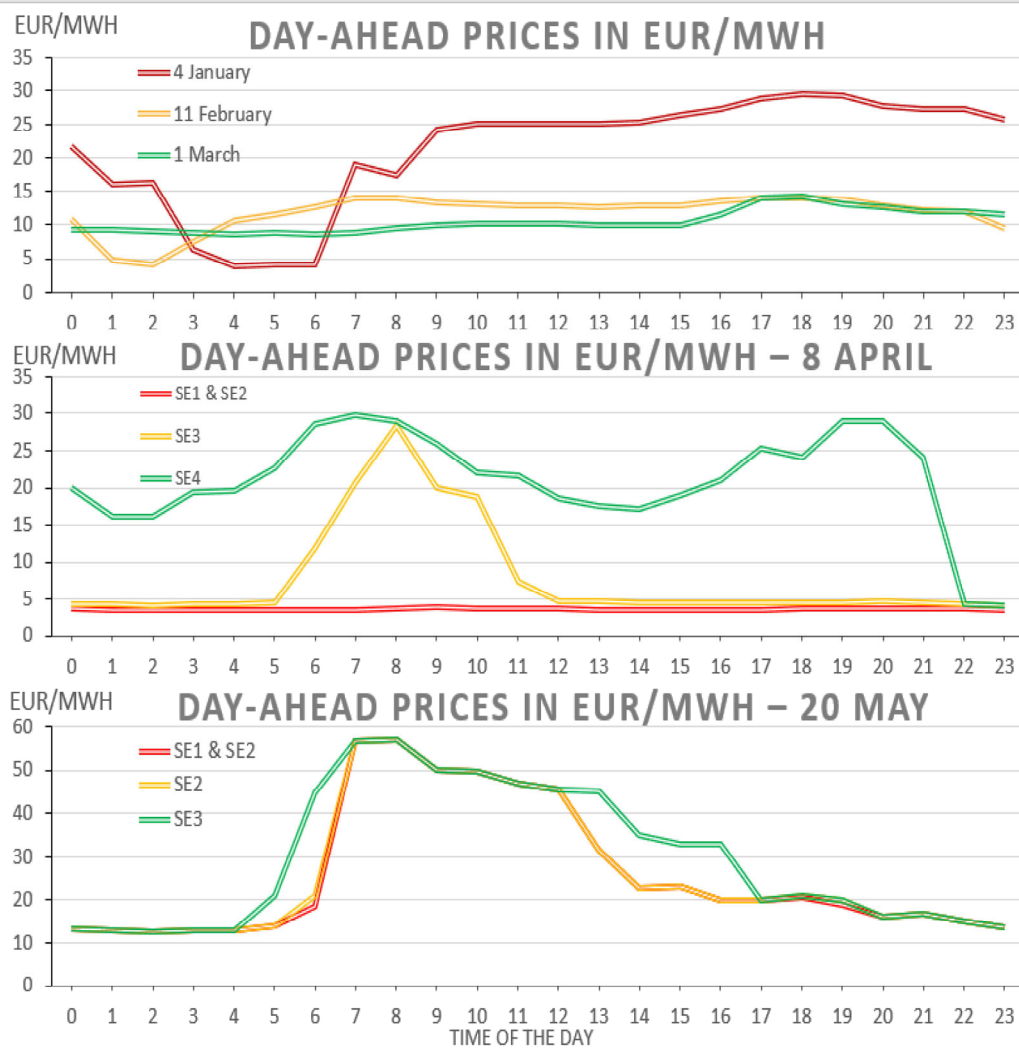


**Figure 7.2:** The average price in EUR/MW when providing FCR-N services for different months.



**Figure 7.3:** The average price in EUR/MW when providing FCR-D services for different months.

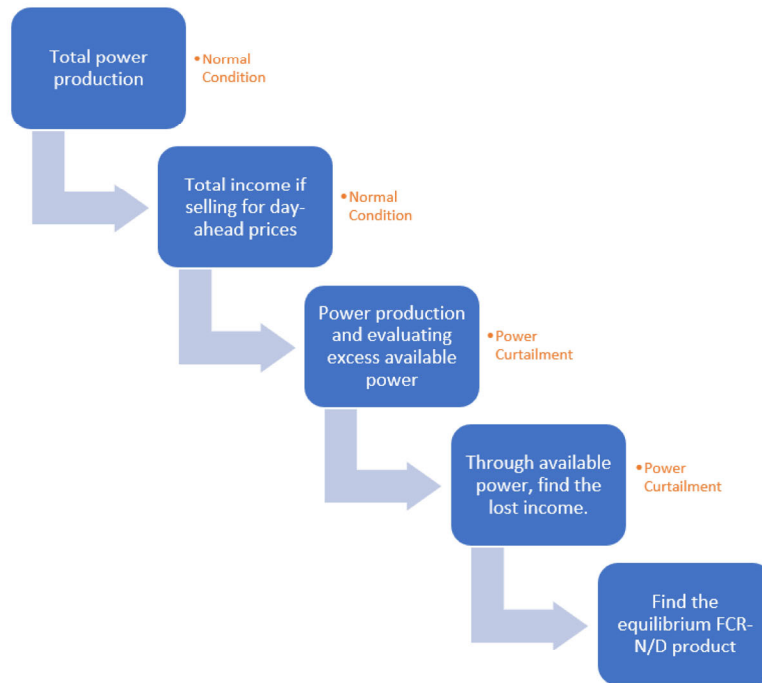
When evaluating the prices in Figure 7.4, it is seen that the prices rise quite significantly during 6 o'clock at the day and remains constant until the end of the day. Moreover, it is seen that for zone SE3 and SE4 is the price higher than the other zones.



**Figure 7.4:** The spot market price for different days and zones.

## 7.2 Generated Power and Potential Income

The algorithm of evaluating the equilibrium quantity of FCR-N and FCR-D is done accordingly as seen in Figure 7.5.



**Figure 7.5:** Algorithm of how the equilibrium quantity of FCR-N and FCR-D is evaluated for no financial loss.

First are the total power production and the generated income presented. After that, the available power during power curtailment for all different scenarios will be found to present the price loss as the excess power is forgoing the power market. The price loss will then be divided with the price of FCR-N and FCR-D, resulting in the minimum necessary quantity of FCR in MWh to not have a financial loss if wind power suppliers provide FCR frequency services.

During the three different wind speed cases that were simulated, the production of the wind farm was computed through integration of the generated power with set intervals for every hour. The sum of generated power during 24 hours in operation resulted in:

- Low wind speed, Case 1 = 105 MWh
- Medium wind speed, Case 2 = 400 MWh
- High wind speed, Case 3 = 720 MWh

A more detailed table can be found in A.6. The measured data was examined with the spot market prices in Chapter 7.1. As there are price variations in different regions in Sweden the following Table 7.1 illustrates the price discrepancies between the regions, during normal operation.

**Table 7.1:** Total income in euro, for each case during the five different days.

Income during different months in EUR (day ahead prices)				
20th May 2020	SE1	SE2	SE3	SE4
Case 1	2726	2726	2743	3091
Case 2	10364	10364	10428	11752
Case 3	18662	18662	18777	21160
8th April 2020	SE1	SE2	SE3	SE4
Case 1	379	379	820	2209
Case 2	1439	1439	3119	8397
Case 3	2592	2592	5616	15120
1st March 2020	SE1	SE2	SE3	SE4
Case 1	1107	1107	1107	1107
Case 2	4206	4206	4206	4206
Case 3	7574	7574	7574	7574
11th February 2020	SE1	SE2	SE3	SE4
Case 1	1242	1242	1242	1242
Case 2	4722	4722	4722	4722
Case 3	8503	8503	8503	8503
4th January 2020	SE1	SE2	SE3	SE4
Case 1	2230	2230	2230	2230
Case 2	8477	8477	8477	8477
Case 3	15264	15264	15264	15264

In the simulation whereas the power was curtailed between 10% to 70% are the amount of MW produced and reserved showcased in Table 7.2. The percent presents the different power curtailments. Moreover, the available power is the excess power for the specific curtailment.

**Table 7.2:** Power production in MWh during power curtailment from 10% to 70%.

	Power Production in MWh							
	10%			30%		50%		70%
	Case 1	Case 2	Case 3	Case 2	Case 3	Case 2	Case 3	Case 3
Sum	30	72	72	214	214	292	359	504
<b>Available</b>	<b>75</b>	<b>328</b>	<b>648</b>	<b>186</b>	<b>506</b>	<b>58</b>	<b>361</b>	<b>216</b>

The economical loss for this action can be seen in Table 7.3, which is the providers economical loss if reserving the output power.

**Table 7.3:** The lost income for forgoing the energy market due to power curtailment during the five different days.

	Day-Ahead income loss for the different months in EUR							
	10%			30%		50%		70%
20th May	Case 1	Case 2	Case 3	Case 2	Case 3	Case 2	Case 3	Case 3
SE1	1944	8502	16796	4821	13116	1503	9357	5599
SE2	1944	8502	16796	4821	13116	1503	9357	5599
SE3	1956	8554	16900	4851	13196	1513	9415	5633
SE4	2204	9640	19045	5467	14871	1705	10610	6348
8th Apr								
SE1	269	1174	2320	666	1811	208	1292	773
SE2	269	1174	2320	666	1811	208	1292	773
SE3	585	2558	5054	1451	3947	452	2816	1685
SE4	1575	6888	13608	3906	10626	1218	7581	4536
1st Mar								
SE1-SE4	789	3451	6817	1957	5323	610	3798	2272
11th Feb								
SE1-SE4	886	3874	7653	2197	5976	685	4263	2551
4th Jan								
SE1-SE4	1588	6944	13718	3938	10712	1228	7642	4573

### 7.2.1 Equilibrium Quantity Estimation

The following Tables 7.4 and 7.5 are the green market numbers profitable and the red marked unprofitable. The numbers presents the amount of MWh in bid size from the FCR products that are required to break even financially. If the number exceeds the available MWh at the bottom at respective case and curtailment then the equilibrium quantity will never be reached. The available MWh at respective table indicates how much MWh is reserved for FCR products and the color visualizes if the FCR products are higher or lower. If lower then the difference it is profitable.

**Table 7.4:** Minimum bidsizes, during one day, of FCR-N if the service is offered without a financial loss.

		Minimum FCR-N Bidsizes in MWh							
		10%			30%		50%		70%
20th May	Case 1	Case 2	Case 3	Case 2	Case 3	Case 2	Case 3	Case 3	
SE1	142	621	1226	352	957	110	683	409	
SE2	142	621	1226	352	957	110	683	409	
SE3	143	624	1234	354	963	110	687	411	
SE4	161	704	1390	399	1085	124	774	463	
8th Apr									
SE1	33	146	289	83	226	26	161	96	
SE2	33	146	289	83	226	26	161	96	
SE3	73	319	630	181	492	56	351	210	
SE4	196	859	1697	487	1325	152	945	566	
1st Mar									
SE1-SE4	70	305	602	173	470	54	335	201	
11th Feb									
SE1-SE4	55	240	474	136	370	42	264	158	
4th Jan									
SE1-SE4	34	149	295	85	231	26	164	98	
Available	75	328	648	186	506	58	361	216	

Profitable  
Unprofitable

**Table 7.5:** Minimum bidsizes, during one day, of FCR-D if the service is offered without a financial loss.

		Minimum FCR-D Bidsizes in MWh							
		10%			30%		50%		70%
20th May	Case 1	Case 2	Case 3	Case 2	Case 3	Case 2	Case 3	Case 3	
SE1	108	473	935	268	730	84	521	312	
SE2	108	473	935	268	730	84	521	312	
SE3	109	476	940	270	734	84	524	313	
SE4	123	536	1060	304	828	95	590	353	
8th Apr									
SE1	44	194	383	110	299	34	214	128	
SE2	44	194	383	110	299	34	214	128	
SE3	97	423	835	240	652	75	465	278	
SE4	260	1139	2249	646	1756	201	1253	750	
1st Mar									
SE1-SE4	60	260	514	148	401	46	286	171	
11th Feb									
SE1-SE4	58	253	500	144	391	45	279	167	
4th Jan									
SE1-SE4	53	230	455	131	355	41	254	152	
Available	75	328	648	186	506	58	361	216	

Profitable  
Unprofitable

# 8

## Concluding remarks

Facing major changes while transitioning requires not only a improved power system but significant changes regarding ancillary services and the Nord Pool market. Thus, in order to evaluate the options of the ancillary services for a WT, a method for power curtailment was simulated with respect to the market. Before the simulations were made, was detailed researches about the different subjects conducted in order to comprehend the frequency services from a power system perspective in order to understand the transition from convention generation to renewable generation regarding frequency regulation.

The major subjects that was studied was: the concepts of the WT, frequency regulation and the electricity market within the Nordic region. The first subject was mainly for understanding of the basic concepts of the WT, the physical principles and how the different aerodynamics are affecting the power output. The two aerodynamics control methods that was studied was pitch and stall regulation. Pitch regulation was utilized as the control platform for the simulation that was made when conducting the simulation cases.

The conclusion drawn from the theoretical subjects was how the different international countries with commercial operating WTs that provided frequency services operated and how they are managing compared to Sweden. Although Sweden is issued via ENTSOE-E, is Sweden a part of the Nordic Area, where the guidelines and requirements can differ from the rest of the synchronous areas as shown in Table 4.1. Furthermore, the characteristic of the system services studied was FFR, FCR, FRR and specified for the different requirements, bids and configurations. It is observed that FRR and FCR are traded within Sweden at present time, however they are not provided from wind power.

The method for simulating a WT was conducted through MATLAB and Simulink. The modelled WT was imitated from a real test plant and three different cases were simulated. These tests were carried out with the intention of imitating a real life scenario, where the different cases was representing different days with varying wind conditions. The cases could refer to spinning reserves, where the generator is operating at less than the maximum output. Hence, APC method was integrated and achieved. From the results where different tariffs analysed considering the actual spot price market for a overview of the financial possibilities and the equilibrium quantity for FCR.

In essence, this thesis shows that if given the right conditions; wind power ancillary services are something to consider as wind power systems fulfill a lot of requirements to provide frequency controls. The characteristics of providing a wide range of different services either as a main or a support provider shows the versatility of the WT as wind power systems are adaptable to other generation resources. Apart from the rapid injection of energy into the systems, are the wind power systems also possible to provide symmetric regulations.

## 8.1 Future works

The transition towards 100% renewable energy is a energy agreement that the government in Sweden is targeting, previously 50% at 2020 which was surprisingly already reached in 2012 [38]. More countries are actively raising interest in involving wind power plants to assist with grid regulation services, especially as wind power is becoming more utilized and the capability range of services provided. As mentioned before, countries throughout the world with full operating wind plants that supplies these services are continually developing and imposing grid codes in transmission systems when the resources are available due to new requirements. As long as the services are developing, is the market developing in the same proportional rate.

The major issue that needs to be addressed are the improvements of the market functionality where fairer and more efficient ways of trading are managed especially for ancillary services. If further development of the market is accomplished, then more responsive and flexible markets are achieved where suppliers are more likely to experience a sufficient profit. Frequency utilization payments would also increase the interest for suppliers. Thus, more frequency services are invoked, and investments and contracts are due, where the profits are expected to cover for forgoing the energy market and eventually the variable and investment costs.

There are a lots of issues that could improve the market, however some major issues to deal with in future within the market are shorter time resolutions for less structural imbalances and faster responsive demands that would probably reduces the price spikes in the market. Considering the ancillary services are improved frequency products and processes required based the adjustment needed and perhaps even new balancing concepts that paves ways for further integration of these services. To conclude, the forthcoming works benefits all the involved actors today and the coming generation in the future.

# Bibliography

- [1] E. Rebello, D. Watson, and M. Rodgers, “Ancillary services from wind turbines: Agc from a single type 4 turbine,” Wind Energy Institute of Canada, Tignish, Canada, Tech. Rep., 2019. [Online]. Available: <https://www.wind-energ-sci-discuss.net/wes-2019-26/wes-2019-26.pdf>
- [2] M. O. Gillian Lalor, Alan Mullane, “Frequency control and wind turbine technologies,” IEEE Transactions on Power Systems, Tech. Rep., 2005. [Online]. Available: <https://doi.org/10.1109/TPWRS.2005.857393>
- [3] J. Aho, A. Buckspan, J. Laks, P. Fleming, Y. Jeong, F. Dunne, M. Churchfield, L. Pao, and K. Johnson, “A tutorial of wind turbine control for supporting grid frequency through active power control,” in *2012 American Control Conference (ACC)*. IEEE, 2012, pp. 3120–3131.
- [4] O. Carlson, A. Perdana, P. Chen, L. Tuan, S. Uski, K. Uhlen, J. EeK, L. Warland, A. Nielsen, J. Østergaard, D. Anca, G. Tarnowski, R. Oidram, I. Palu, H. Agabus, and O. Tšernobrovkin, *Model Development for Power System Analysis with a Substantial Wind Energy Capacity Installed in the Nordic grid*, 01 2011.
- [5] A. D. Hansen, “Evaluation of power control with different electrical and control concepts of wind farms,” Project UpWind, Roskilde, Denmark, Tech. Rep., 2010. [Online]. Available: <https://orbit.dtu.dk/en/publications/evaluation-of-power-control-with-different-electrical-and-control>
- [6] S. Kraftnat. (2020) System development plan 2018-2027. [Online]. Available: <https://www.svk.se/siteassets/om-oss/rapporter/2018/svenska-kraftnat-system-development-plan-2018-2027.pdf>
- [7] N. W. Miller and K. Clark, “Advanced controls enable wind plants to provide ancillary services,” in *IEEE PES General Meeting*. IEEE, 2010, pp. 1–6.
- [8] D. Chatterjee and Z. Rather, “Modelling and control of dfig-based variable speed wind turbine,” Tech. Rep., 07 2018.
- [9] W. J. Jonkman, S. Butterfield and G. Scott, “Definition of a 5-mw reference wind turbine for offshore system development,” Office of Energy Efficiency and Renewable Energy, Colorado, Tech. Rep., 2009. [Online]. Available: <https://www.nrel.gov/docs/fy09osti/38060.pdf>
- [10] E. Muljadi, C. Butterfield, and M. Buhl, “Effects of turbulence on power generation for variable-speed wind turbines,” 11 1996.
- [11] D. Li and C. Chen, “Comparison of energy efficiency between fixed-speed and variable-speed wind turbines,” *Energy Engineering*, vol. 101, no. 6, pp. 71–80, 2004. [Online]. Available: <https://doi.org/10.1080/01998590409509286>
- [12] T. Ackermann, *Wind power in power systems*. John Wiley & Sons, 2005.

- 
- [13] E. Hau, *Wind turbines: fundamentals, technologies, application, economics*. Springer Science & Business Media, 2013.
- [14] L. Vermeer, J. N. Sørensen, and A. Crespo, “Wind turbine wake aerodynamics,” *Progress in aerospace sciences*, vol. 39, no. 6-7, pp. 467–510, 2003.
- [15] B. Sanderse, “Aerodynamics of wind turbine wakes-literature review,” 2009.
- [16] L. Åke, “Power quality of wind turbine generating systems and their interaction with the grid,” Chalmers University of Technology, Göteborg, Sweden, Tech. Rep.
- [17] Understanding coefficient of power  $c_p$  and betz limit. [Online]. Available: [http://cdn.teachersource.com/downloads/lesson\\_pdf/betz\\_limit\\_0.pdf](http://cdn.teachersource.com/downloads/lesson_pdf/betz_limit_0.pdf)
- [18] D. R. M. Andres. Betz limit. [Online]. Available: <http://www.reuk.co.uk/wordpress/wind/betz-limit/>
- [19] P. Circle, “Stödtjänster från nya tekniker: Fakta blad från power circle,” Power Circle AB, Stockholm, Sweden, Tech. Rep., 2019. [Online]. Available: <http://www.powercircle.org/stodtjanster.pdf>
- [20] K. Svenska. Avtal om balansansvar för el mellan affärsverket svenska kraftnät ("svenska kraftnät") och. [Online]. Available: <https://www.svk.se/siteassets/aktorsportalen/elmarknad/balansansvar/dokument/arkiverat/2017-02-22-reviderat-avtal-2628-1-med-andringar-synliggjorda.pdf>
- [21] *Nordic grid code (nordic collection of rules)*, Std. Nordel, 2007.
- [22] K. Svenska. Översiktlig kravbild för reserver. [Online]. Available: <https://www.svk.se/siteassets/aktorsportalen/elmarknad/information-om-reserver/reservmarknader.pdf>
- [23] Fast frequency response in the nem. [Online]. Available: [https://www.aemo.com.au/-/media/Files/Electricity/NEM/Security\\_and\\_Reliability/Reports/2017/FFR-Working-Paper---Final.pdf](https://www.aemo.com.au/-/media/Files/Electricity/NEM/Security_and_Reliability/Reports/2017/FFR-Working-Paper---Final.pdf)
- [24] N. Modig and R. Eriksson, “Technical requirements for fast frequency reserve provision in the nordic synchronous area,” European Network of Transmission System Operators for Electricity, Brussels, Belgium, Tech. Rep., 2019. [Online]. Available: <https://www.svk.se/siteassets/aktorsportalen/tekniska-riktlinjer/ovriga-instruktioner/technical-requirements-for-fast-frequency-reserve-provision-in-the-nordic-synchronous-area-1.pdf>
- [25] NERC, “Balancing and frequency control a technical document prepared by the nerc resources subcommittee,” North American Electric Reliability Corporation, Princeton, The United States of America, Tech. Rep., 2011. [Online]. Available: <https://www.nerc.com/docs/oc/rs/NERC%20Balancing%20and%20Frequency%20Control%20040520111.pdf>
- [26] M. Persson, “Frequency response by wind farms in power systems with high wind power penetration,” PhD dissertation, Chalmers University of Technology, 2017, 978-91-7597-597-9.
- [27] “Eirgrid grid code version 6.0,” EirGrid, Tech. Rep., 2015.
- [28] “Regulations for grid connection,” Energinet.dk, Tech. Rep., 2016.
- [29] “Grid code,” Tennet TSO GmbH, Tech. Rep., 2015.

- 
- [30] “Wind farm transmission grid code provisions: A direction by the commission for energy regulation,” Commission for Energy Regulation, Dublin, Ireland, Tech. Rep., 2004.
- [31] “Technical requirements for the connection of generation facilities to the hydro-quebec transmission system: Supplementary requirements for wind generation,” Hydro-Quebec, Montreal, Quebec, Canada, Tech. Rep., 2005.
- [32] “Wind turbines connected to grids with voltages above 100kv: Technical regulation for the properties and the regulation for wind turbines,” Elkraft System and Eltra, Erritsø, Denmark, Tech. Rep., 2003.
- [33] “Technical requirements for wind power and photovoltaic installations and any generating facilities whose technology does not consist of a synchronous generator directly connected to the grid,” Red Electrica, Madrid, Spain, Tech. Rep., 2008.
- [34] (2020) Nord pool market. [Online]. Available: <https://www.nordpoolgroup.com/>
- [35] (2017) Balance in grid. [Online]. Available: <https://www.svk.se/drift-av-transmissionsnatet/drift-och-emarknad/balans-i-natet/>
- [36] E. Ela, B. Kirby, N. Navid, and J. Smith, “Effective ancillary services market designs on high wind power penetration systems,” *Conference Paper NREL/CP*, pp. 5500–53 514, 07 2012.
- [37] Primary regulation. [Online]. Available: <https://mimer.svk.se/PrimaryRegulation/PrimaryRegulationIndex>
- [38] Energy use in sweden. [Online]. Available: <https://sweden.se/nature/energy-use-in-sweden/>

# A

## Appendix 1

### A.1 Day-Ahead Price for FCR-N between the months January and May 2020

**Table A.1:** The average price in EUR/MW when providing FCR-N services on different days.

Time	FCR-N				
	4th Jan	11th Feb	1st Mar	8th April	20th May
0	64,64	30,96	12,45	8,76	14,51
1	63,80	34,64	12,52	8,65	13,06
2	63,61	34,82	12,68	8,91	13,11
3	64,41	35,75	12,64	8,88	13,10
4	64,45	34,47	12,62	8,72	13,80
5	63,53	19,65	12,42	8,26	13,91
6	57,37	12,16	11,25	8,02	14,10
7	43,77	12,21	11,32	8,17	17,58
8	42,07	12,24	11,36	8,26	17,58
9	38,11	10,28	10,79	7,59	13,33
10	36,20	10,21	10,79	7,39	12,88
11	37,52	10,17	10,69	7,42	12,86
12	36,12	10,05	11,24	7,37	18,88
13	35,86	10,00	11,21	7,37	13,93
14	35,82	10,00	11,31	7,47	13,97
15	36,13	10,00	10,90	7,89	14,36
16	36,71	9,97	10,41	7,88	13,65
17	36,52	9,94	10,54	7,87	13,58
18	35,27	10,23	10,44	7,87	10,97
19	39,71	10,22	10,37	7,93	10,61
20	39,78	10,19	10,34	7,98	10,67
21	41,84	12,63	10,88	7,88	12,44
22	50,36	13,07	11,35	7,96	12,42
23	51,69	13,69	11,30	8,04	13,39

## A.2 Day-Ahead Price for FCR-D between the months January and May 2020

**Table A.2:** The average price in EUR/MW when providing FCR-D services on different days.

Time	FCR-D				
	4th Jan	11th Feb	1st Mar	8th April	20th May
0	44,07	21,61	13,07	6,01	14,01
1	46,13	23,25	14,56	6,04	13,90
2	46,18	23,18	13,50	6,27	13,39
3	46,18	21,50	14,96	6,32	13,36
4	46,13	21,54	14,98	6,29	13,83
5	45,92	17,90	14,19	6,53	14,32
6	47,94	14,89	14,87	6,62	23,04
7	27,66	14,50	13,52	6,69	26,68
8	26,97	14,50	15,27	6,64	26,81
9	23,46	11,36	11,79	5,76	23,64
10	21,93	11,36	11,32	5,85	23,88
11	22,44	11,91	10,88	5,82	23,74
12	22,48	11,26	10,44	5,72	22,06
13	19,94	11,26	10,45	5,74	17,29
14	19,75	10,90	10,82	5,63	17,33
15	20,10	11,38	11,12	5,58	16,44
16	20,19	11,58	12,41	5,71	15,82
17	19,89	11,64	14,86	5,82	16,59
18	21,32	11,59	12,82	5,91	16,84
19	21,42	11,95	12,53	5,93	15,82
20	21,38	11,75	12,44	5,75	15,52
21	24,72	18,40	15,95	6,17	15,99
22	33,49	19,32	15,55	6,21	15,58
23	33,56	18,76	15,84	6,19	15,49

### A.3 Day-Ahead prices in January, February and March 2020

**Table A.3:** Day-ahead price 4th January-, 11th February- and 1st March- 2020 in EUR/MWh.

	Day-Ahead Prices in EUR/MWh		
	1st Mar	11th Feb	4th Jan
Time	SE-1/2/3/4	SE-1/2/3/4	SE-1/2/3/4
00 - 01	9,32	10,96	21,73
01 - 02	9,34	4,83	15,95
02 - 03	9,13	4,04	16,23
03 - 04	8,89	7,52	6,45
04 - 05	8,73	10,62	3,83
05 - 06	8,86	11,55	4,03
06 - 07	8,61	12,68	4,04
07 - 08	8,9	13,95	19,07
08 - 09	9,43	14,11	17,49
09 - 10	9,87	13,32	24,18
10 - 11	10,24	13,11	24,94
11 - 12	10,27	13	25,11
12 - 13	10,11	12,85	24,94
13 - 14	9,99	12,77	24,95
14 - 15	9,94	13	25,25
15 - 16	9,96	12,94	26,33
16 - 17	11,59	13,67	27,36
17 - 18	13,94	14,12	28,88
18 - 19	14,22	14,06	29,58
19 - 20	13,09	13,73	29,42
20 - 21	12,59	12,94	27,71
21 - 22	11,99	12,22	27,4
22 - 23	11,89	11,92	27,37
23 - 00	11,49	9,58	25,77
Min	8,61	4,04	3,83
Max	14,22	14,12	29,58
Average	10,52	11,81	21,17
Peak	11,05	13,39	25,7
Off-peak1	8,97	9,52	11,42
Off-peak2	11,99	11,67	27,06

## A.4 Day-Ahead Price in April 2020

Table A.4: Day-ahead price 8th April 2020 in EUR/MWh.

Day-Ahead Prices in EUR/MWh 8th April 2020				
Time	SE1	SE2	SE3	SE4
00 - 01	3,59	3,59	4,38	20,04
01 - 02	3,57	3,57	4,25	16,07
02 - 03	3,54	3,54	4,19	16,09
03 - 04	3,52	3,52	4,2	19,39
04 - 05	3,5	3,5	4,29	19,61
05 - 06	3,47	3,47	4,52	22,59
06 - 07	3,41	3,41	11,93	28,63
07 - 08	3,58	3,58	20,71	29,7
08 - 09	3,68	3,68	28,28	29,08
09 - 10	3,8	3,8	20,04	25,91
10 - 11	3,78	3,78	18,77	21,95
11 - 12	3,72	3,72	7,44	21,69
12 - 13	3,59	3,59	4,77	18,62
13 - 14	3,48	3,48	4,65	17,49
14 - 15	3,46	3,46	4,58	17,15
15 - 16	3,45	3,45	4,52	19,08
16 - 17	3,47	3,47	4,5	21,03
17 - 18	3,55	3,55	4,51	25,28
18 - 19	3,6	3,6	4,5	24,08
19 - 20	3,69	3,69	4,56	29,02
20 - 21	3,7	3,7	4,61	29,07
21 - 22	3,66	3,66	4,53	24,08
22 - 23	3,62	3,62	4,35	4,35
23 - 00	3,57	3,57	4,1	4,1
Min	3,41	3,41	4,1	4,1
Max	3,8	3,8	28,28	29,7
Average	3,58	3,58	7,8	21
Peak	3,61	3,61	9,26	22,53
Off-peak1	3,52	3,52	7,31	21,52
Off-peak2	3,64	3,64	4,4	15,4

## A.5 Day-Ahead Price in May 2020

Table A.5: Day-ahead price 20th May 2020 in EUR/MWh.

Day-Ahead Prices in EUR/MWh 20th May 2020				
Time	SE1	SE2	SE3	SE4
00 - 01	13,36	13,36	13,36	13,36
01 - 02	12,9	12,9	12,9	12,9
02 - 03	12,78	12,78	12,78	12,78
03 - 04	12,84	12,84	12,84	12,84
04 - 05	12,92	12,92	12,92	12,92
05 - 06	14,14	14,14	14,14	21,09
06 - 07	18,5	18,5	20,94	44,83
07 - 08	56,69	56,69	56,69	56,69
08 - 09	57	57	57	57
09 - 10	49,96	49,96	49,96	49,96
10 - 11	49,74	49,74	49,74	49,74
11 - 12	46,88	46,88	46,88	46,88
12 - 13	45,48	45,48	45,48	45,48
13 - 14	31,54	31,54	31,54	44,98
14 - 15	22,93	22,93	22,93	35,03
15 - 16	23,06	23,06	23,06	33,05
16 - 17	19,95	19,95	19,95	33,01
17 - 18	20,06	20,06	20,06	20,06
18 - 19	20,52	20,52	20,96	20,96
19 - 20	19,01	19,01	19,97	19,97
20 - 21	16,04	16,04	16,04	16,04
21 - 22	16,95	16,95	16,95	16,95
22 - 23	15,2	15,2	15,2	15,2
23 - 00	13,62	13,62	13,62	13,62
Min	12,78	12,78	12,78	12,78
Max	57	57	57	57
Average	25,92	25,92	26,08	29,39
Peak	33,84	33,84	33,96	38,01
Off-peak1	19,27	19,27	19,57	23,43
Off-peak2	15,45	15,45	15,45	15,45

## A.6 Generated Power

Power Production in MW			
Time	Case 1	Case 2	Case 3
0	1,63	12,56	30,00
1	7,13	21,78	30,00
2	5,76	19,13	30,00
3	3,27	14,36	30,00
4	6,78	21,11	30,00
5	4,28	16,11	30,00
6	3,78	15,12	30,00
7	2,95	13,85	30,00
8	5,95	19,51	30,00
9	1,63	12,53	30,00
10	4,12	15,76	30,00
11	7,36	22,20	30,00
12	3,61	14,80	30,00
13	4,41	16,39	30,00
14	3,83	15,18	30,00
15	6,93	21,43	30,00
16	7,15	21,85	30,00
17	1,90	12,80	30,00
18	2,24	12,99	30,00
19	2,37	13,05	30,00
20	5,86	19,35	30,00
21	5,58	18,78	30,00
22	4,08	15,71	30,00
23	2,57	13,52	30,00
<b>Sum</b>	<b>105,18</b>	<b>399,85</b>	<b>720,00</b>

Figure A.1: The hourly power and total production for all three cases in MW.