

Renovation for the future

An investigation of environmental impact and lifecycle costs from design choices during a renovation project

Johanna Olin
Chalmers School of Architecture
Department of Architecture and Civil Engineering

Examiner: Paula Femenias
Supervisor: Walter Unterrainer
Studio: Bulding Design for Sustainability 2023



CHALMERS
UNIVERSITY OF TECHNOLOGY

Renovation for the future

2023

Johanna Olin

Chalmers School of Architecture

Department of Architecture and Civil Engineering

Architecture and Planning Beyond Sustainability (MPDSD)

Examiner: Paula Femenias

Supervisor: Walter Unterrainer

ABSTRACT

Many of the buildings made in the 1960s to 1970s are today in urgent need of renovation. To be able to reach the goal of net-zero emissions by 2045 they are also in need of improved energy efficiency. While decreased energy usage after renovations leads to lower environmental impact, it also leads to long-term lower costs. With selection of lasting materials, it is also possible to lower the cost for maintenance. By performing life cycle assessments (LCA) and life cycle costs (LCC) on different design options of a future renovation project, this thesis investigates the interrelation between building costs and environmental impact alongside architectural qualities.

The thesis focuses on the renovation of an apartment building in Gårdsås in Gothenburg, where renovations have been initiated on buildings of the same type. Data from the already performed renovations will be used as reference for further investigations on one of the buildings that is still to be renovated. The previous renovations affected the facades and outside areas, and the future renovations will be including a pipe exchange and renovation of bathrooms. These actions together with the façade renovation means that the tenants must be relocated during the renovation and more extensive renovations performed. This thesis aims to present an alternative to this renovation where the design choices are motivated by the result of the cost and environmental assessments.

Previous studies show that there is currently a lack of models to consider long term economical gain in public renovation projects. Since public housing companies have a larger responsibility to be socially sustainable, the balance between economical gain and increased rents becomes vital. Life cycle assessments show in a holistic way the climate impact of a building over its lifetime and can be used in an early design process to investigate different options. By simultaneously investigating life cycle costs, this thesis aims to motivate sustainable solutions with lower long-term costs over a building's lifetime. Additionally, the thesis aims to provide a basis for further discussion on the responsibility for renovation costs.

ACKNOWLEDGEMENTS

Many thanks to everyone who made this thesis possible!

To Walter Unterrainer and Paula Femenias for the support and guidance through the process and for providing your expertise to move the project forward.

To Josephina Wilson and Camilla Wictorsson at Familjebostäder for providing information, knowledge and bringing a real-life perspective to the project.

To Matthias Othzen at PSAB for providing the information and data needed to make the investigation at all possible.

To Alexander Hollberg for the guidance and support in CAALA.

Thanks also to my family for the many supportive phone calls.

ABOUT THE AUTHOR

The motivation behind this thesis was a curiosity on costs and a wish to combine economy with environmental sustainability and design.

In my previous experiences I have gotten the opportunity to work in the space in between the architect and the engineer and the diversity of the role of the architect was something I wished to explore further with this thesis.

BSc Architecture & engineering

Chalmers University of Technology

2017-2020

Year in Industry Internship

Sustainability and physics, Buro Happold, London

2020-2021

MSc Architecture & planning beyond sustainability

Chalmers University of Technology

2021-

TABLE OF CONTENTS

INTRODUCTION

BACKGROUND & THESIS MOTIVATION.....	5	STONE WOOL VS CELLULOSE & WOOD FIBRE.....	49
AIM.....	5	NEW DESIGN SUGGESTION.....	50
METHOD.....	6	FINAL RESULT.....	54
DELIMITATION.....	7		
ABBREVIATIONS & TERMINOLOGY.....	7		

THEORY

ECONOMY & THE RENTAL APARTMENT.....	8
LIFE CYCLE ASSESSMENTS.....	10
FUTURE ENERGY AND BUILDING COSTS.....	13
RENOVATION EXAMPLES.....	14

CASE STUDY

THE SITE.....	20
TENANT INTERVIEWS.....	23
BUILDING TIMELINE.....	24
ORIGINAL FLOORPLANS.....	26
BUILDING INFORMATION.....	28
RENOVATION COSTS.....	29
EXTERNAL RENOVATION MEASURES.....	30
INTERNAL RENOVATION MEASURES.....	32
RENOVATION OF THE GARAGE.....	32
PLANNED HOUSING.....	33
CAALA MODEL SETTINGS.....	34
RESULTS BEFORE AND AFTER RENOVATION.....	36

INVESTIGATION

RENOVATION OR DEMOLITION.....	38
REMOVING THE GARAGE.....	40
GLAZING OF THE BALCONIES.....	42
FTX SYSTEM.....	43
COMMENT ON WINDOWS.....	43
INSULATION OF THE SOUTERRAIN FLOOR.....	44
WALL CONSTRUCTION.....	46
CEMENT FIBREBOARD VS WOOD PANEL.....	48

DISCUSSION

IN RESPONSE TO THE THESIS QUESTIONS.....	56
PROCESS REVELATIONS.....	58

INTRODUCTION

BACKGROUND & THESIS MOTIVATION

In the Paris agreement, the EU set the goal to reach net-zero carbonisation by 2050. In Sweden the government has set the goal of net-zero emissions by 2045. As the built environment stands for 36% of the greenhouse gas emissions in the EU, the building sector plays an important role in reaching the net-zero goals (Kruit et al., 2020). In 2017 it was estimated that 800 000 buildings in Sweden needs to be renovated, 300 000 of those buildings are located in million program areas and are in urgent need of renovation. When renovating these buildings there is opportunity to lower their energy usage and with it, their environmental impact (Johansson, 2017).

The UN states in the sustainable development goal 11.2 the aim to reach safe and affordable housing for all. The right to housing for all is also written in the Swedish constitution (Kurvinen 2020). According to Kurvinen, there isn't a general housing shortage in Sweden but rather a shortage of affordable housing. Additionally, there are in general lower income rates in the million program areas and a big standard increase of apartments risk causing people having to move (Stenberg, 2020).

While interviews with a public housing company in Sweden indicated that there is a positive outlook on the inclusion of long-term economic gain in profitability calculations, there is a lack of models on how to include them (Jonsson & Stiller, 2016). Incorporating lifecycle costs in business models is a potential method for capturing the long-term economic gain from a project (Femenías et al., 2018). Life cycle assessments can in a holistic way show the environmental and economic impact of a building over its lifetime and is best used early in a design process to investigate different design options (Hollberg et al., 2016).

AIM

To provide knowledge on alternative renovation designs for low environmental impact as well as low costs from a lifecycle perspective.

As part of the movement towards the net-zero goal and in preparation for the maintenance needed, the housing company Familjebostäder is currently in the process of collecting data for climate investigation on their building stock. Part of the aim for this thesis will be to utilize my own collected data to provide insight for Familjebostäders future adjustments towards sustainable housing.

The main aim of the project is to answer the question:

By extending a building's life length and lowering its energy usage, what are the possibilities to lower the cost and the environmental impact of a renovation while maintaining or improving on architectural qualities?

And then as follow up questions:

Can lower lifecycle costs be motivation for choosing environmentally sustainable solutions in the building sector?

Can lower lifecycle costs of a building be used as motivation for setting lower rents?

METHOD

The thesis will be divided into two phases, a “research on design” phase and then a “research by design” phase. First an already performed renovation process will be applied to the planned project. After the initial results have been collected, further investigation will be done using the test results as a base.

Preparation

Investigation of costs and LCA and how they currently are used in the industry in regard to architecture and sustainability.

Selection of which LCA tool to use and which limitations the investigation should have.

Gathering of information on design choices of renovations to test from theoretical and real renovation processes.

Looking into potential tenant interviews before or after renovations in Gärdsås to find stakeholder wishes and needs.

Investigation of the site and area context.

For the LCC to be performed during the user phase, an estimation of future energy prices should be made and an estimation of future construction costs.

Phase 1 - Investigation of an already performed renovation

Collection of available drawings and models of the investigated building and of the building that has already been renovated.

Collection of data within the limitation scope of the LCA and LCC, such as material amounts, material costs, and energy usage from one of the renovations in Gärdsås.

CAALA modelling and input preparation.

LCA and LCC performed on the original renovation and evaluation.

Preparation of a new design proposal.

Phase 2 - Investigation of new design options

Investigation of the building context and cost impact from the added apartments.

Adjustment of the material, geometry and technical equipment from phase 1 to fit the new design.

LCA and LCC performed on the alternative renovation options.

Evaluation of qualities.

Final conclusions

Gathering of results into a new renovation proposal and a concluding reflection over the test results.

Detailed timeline phase 2

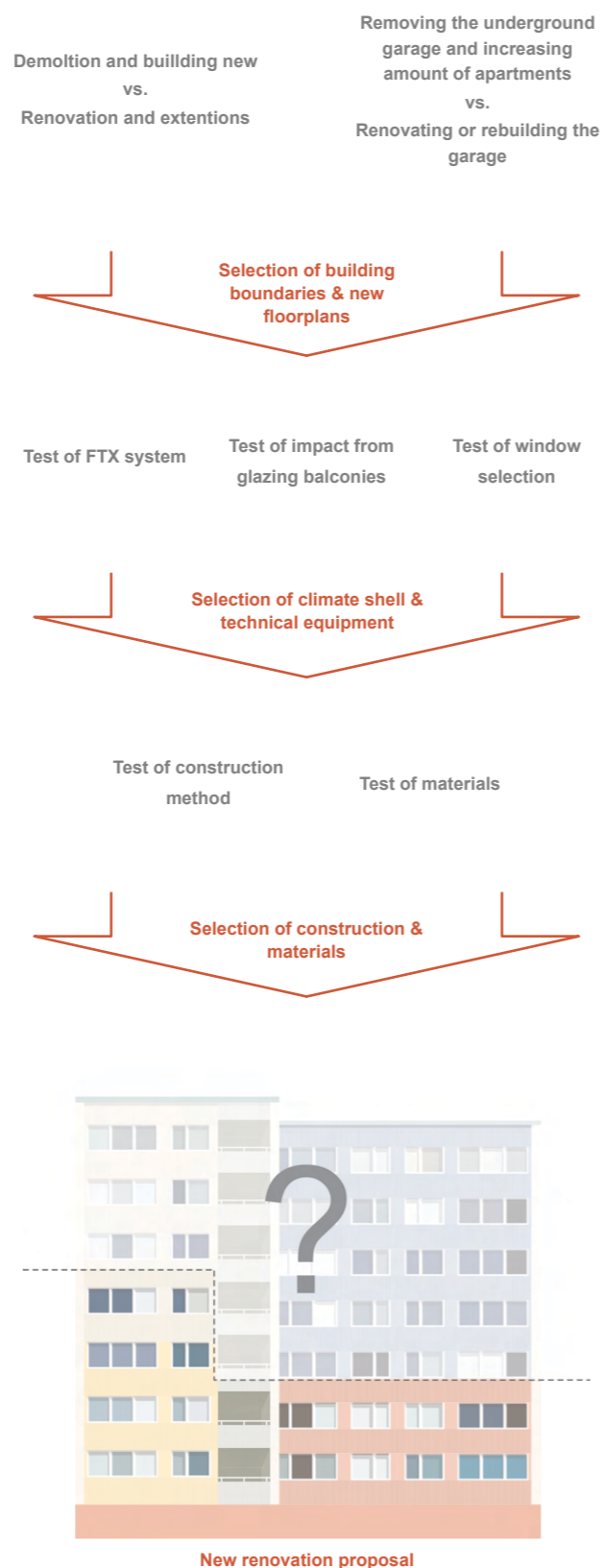

DELIMITATION

The case example is limited to the site in Gärdsås where the public housing company Familjebostäder currently is in the process of renovating. Since the renovation of million program areas is commonly performed both in Sweden and in the rest of Europe, the specific detail plan of the site won't be strictly followed to fully investigate the potential solutions. Whenever the project diverges from the detail plan it will be stated.

Previous studies of renovations in million program areas in Sweden has shown that there is a lack in sufficient communication between the tenants and the housing company. In the million program areas there are also in general a lower income rate and a big standard increase of apartments risk causing people having to move due to high rents (Stenberg, 2020). In this project I won't be addressing in depth the socioeconomic challenges of Gärdsås and the million programs in Sweden other than factors directly connected to the economy of the project. The renovations in Gärdsås have been nominated by the Public Housing Sweden (Svensk Allmännytt) as one of the best renovations in Sweden for its communication with tenants and careful renovation process, the result of this process will be used as part of the motivation behind the design choices.

ABBREVIATIONS & TERMINOLOGY

Air tightness: The air exchange rate of a building at 50 Pa pressure difference from the inside to the outside

BOA: Gross housing area, usable apartment area including room dividing walls thinner than 30 cm

CCI: Construction cost index, representation of the entire private domestic consumption, in Sweden the CCI is the standard measure for calculation of inflation

CPI: Consumer price index, representation of the price trend for production in the housing sector such as costs for material, equipment and salaries

EPD: Environmental product declaration, describes the environmental impact from a product over its lifetime.

GFA: Gross floor area, the full building floor area including external walls

GWP: Global warming potential, a measurement of environmental impact by translating emissions to carbon dioxide equivalents

LCA: Lifecycle assessment, a method for calculating the accumulated environmental impact over a building's lifetime

LCC: Lifecycle costs, a method for calculating the total costs over a building's lifetime

NFA: Net floor area, the building's heated usable floor area without including external walls and internal walls thicker than 15 cm

NOI: Net operational income, difference between the operational costs and the operational incomes

Primary energy demand: The energy demand of a building as taken from different energy sources such as oil, coal or hydropower. Depending on the source it is calculated using different factors

Thermal bridges: Parts of the building envelope that causes higher heat loss compared to the rest of the building surfaces, for example due to a weak spot in the construction.

U-value: Thermal transmittance of a construction part [W/m²K]

VAT: Value added tax, governmental tax added to the prize of a product

λ -value: Thermal conductivity of a material [W/mK]

THEORY

ECONOMY & THE RENTAL APARTMENT

History

Since the construction of the million program areas in the 70s, the economic conditions for housing have undergone many changes. During the banking and real-estate crisis in the 90s, the Swedish government decided to remove the public financing of housing and started phasing out public subventions. The idea was for the public housing companies to be independently financed by producing housing requested by the market, leading to an alignment of public housing companies and private companies. This was strengthened further by a new law in 2011 stating that public housing companies needed to act business-like. (Kurvinen, 2020).

These reforms have led to a complexity of the role of public housing companies. In a master's thesis by Jonsson and Stiller (2016) they conducted interviews with Familjebostäder regarding sustainability and business-like behaviour in relation to a renovation. It was stated that social and environmental benefits often are viewed as opposing measures to the economic gain, and that it can be difficult to find a balance between them.

The removal of interest subsidies has led to new production of rental apartments becoming inaccessible for households with low income. Economically accessible housing is instead limited to the housing supply within the built environment where rents have been maintained relatively low due to the utility value system (Kurvinen, 2020). The increased rents after renovations in the built environment today is problematic since there isn't many alternatives for the people who can no longer afford to stay.

State of subventions

The investment support for production of rental housing was reinstated 2016 (Kurvinen, 2020), but has since been removed at the turn of the year 21/22, as was the public subvention for energy efficiency in apartment buildings. Another subvention that could have been of interest to renovation in million program areas is the subvention for renovation and energy efficiency of buildings in some residential areas which was removed in 2019.

In the previous renovations at Siriusgatan a subvention for outdoor spaces in vulnerable areas was utilised which has since been removed as well.

While increasing public subventions is a common suggestion to reduce the high rents, limited access to attractive land leads to subsidised apartments only being available to a selected few. An alternative could be to invest in improved infrastructure to improve access to remote areas and relieve the pressure in central areas (Kurvinen, 2020).

Production costs

The rents in Sweden are determined by a collective evaluation of the living quality and the utility value. The price for rental apartments is consequently more dependent on production costs compared to for example condominium prices that are primarily determined by the state of the market. An alternative for housing companies is to set a presumption rent that doesn't have to be aligned with the utility value until after 15 years. The presumption rents would however be negotiated together with the tenant's union and would still be partly based on the costs. It is also possible for a housing company to negotiate the rent directly with the tenant, but those rents can be investigated by the tenant after 6 months and re-determined if they don't follow the utility value principle.

The production cost can be divided into building costs, cost for the developer, and VAT and are generally divided as illustrated in figure 1.

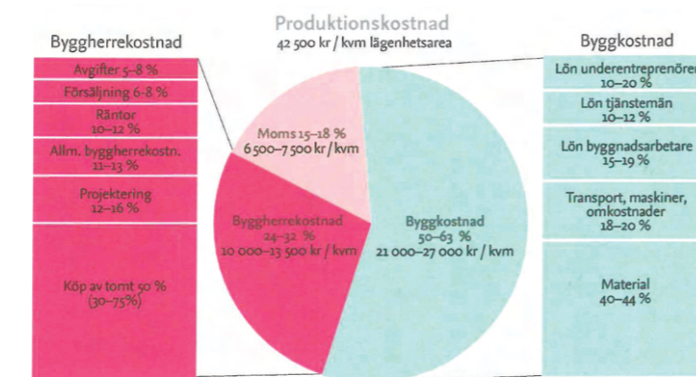

Figure 1: Illustration showing general division of production costs

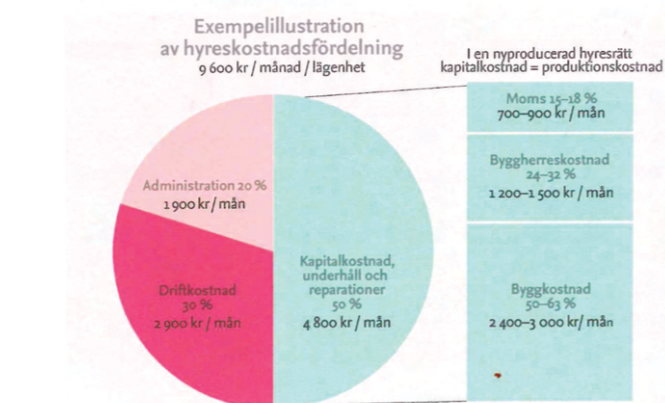

Figure 2: Illustration showing general division of rental costs

The costs included in the rent are also dependent on costs for administration and operation costs as illustrated in figure 2. Consequently, if the building's costs were to be reduced by 20% it would only lead to a total reduction of rent by 5%. While high building costs often is blamed for increased rents, this shows that it can't be the only cause.

Required rate of return

The required rate of return is the lowest level of profit an owner is accepting for an investment and has high impact on profitability calculations. The required rent of return can be defined using several different methods, either as a sum of risks or as different relations between the net operative income and market value.

The rate of return is lower in central attractive areas since they are considered to have lower risk for vacancies compared to more remote areas. To make up for the risk of vacancies a higher required rate of return leads to increased rents. Kurvinen (2020) questions the relevancy of this system in Sweden today since the housing shortage has led to an overall low vacancy risk. The higher rate of return in remote areas is also problematic since the higher rent on its own causes a higher risk of vacancies. Since people are willing to pay more for central areas, the rents for new production in central areas tend to be higher anyways. Due to the current low risk of vacancies, the required rate of return used by the Framtiden Group in Gothenburg has over the last years been lowered in general. There is also a smaller difference between different areas.

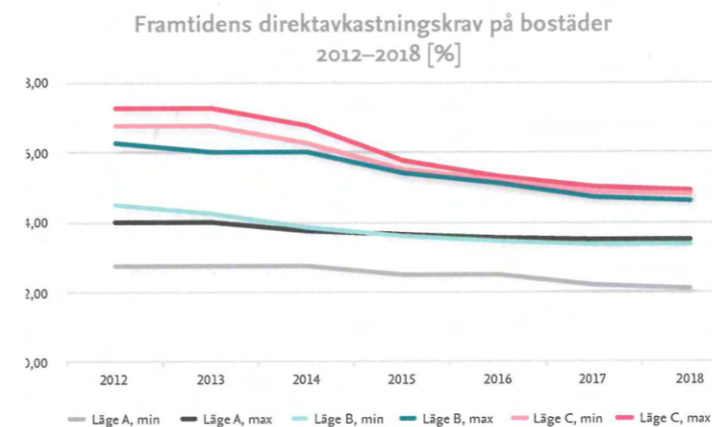

Figure 3: Development of required rate of return from the Framtiden group

To show their economic activity companies must account for their expenses. There are currently two different accounting methods, the K2 method that considers the building as one unit and the K3 method where the building is split into its different components. Larger companies (such as Familjebostäder) are required to use the K3 method. Due to the division into components, the resource consumption in the K3 method is divided over the lifetime of each component. In an example presented by Kurvinen (2020) the rents were kept at a low level by connecting the required rate of return to the discrepancy period. With the adapted profitability calculation, the profitability of the project increased by choosing building components with longer life lengths – which also has environmental benefits. Today this

might be more difficult to do due to the increased production costs and removal of subventions.

Alternative business model

In their master's thesis Jonsson and Stiller (2016) discusses alternative ways for public housing companies to perform their business strategy when it comes to renovations. They explain that the current focus on expenses in the early project stage leads to negative economic impact from environmental and social investments since they in general only show positive impact after a certain amount of time has passed. While interviews with Familjebostäder showed that shifting towards a long-term focus was in general viewed positively, it was also stated that proper models to do so are currently lacking. On the other hand, it was argued for a large potential of long-term thinking since public housing companies are backed by taxpayers and politicians and are not as dependent on quarterly reports as private housing companies. An issue brought up was the lack of consideration to NOI (net operational income) and that while environmental measures decreased energy usage, they don't consider how the NOI will increase over time.

The interviews showed diverse views of the system with rent increase due to increase of apartment standard. Since it is usually the main source of income of a project, a balance between social benefits and economy needs to be weighed against each other. A statement was made that the standard rent impact on tenants is problematic since it dictates what technical and environmental measures can be done. Usually there is a gradual increase of the rent, split over several years. In the final value capturing part of the business strategy, Jonsson and Stiller discusses the need for public housing companies to be able to calculate socio-economic benefits from a project. A direct connection between economic profit and social improvement could be crucial for a project, such as the renovation in Gärdås, where the social implications have a large impact.

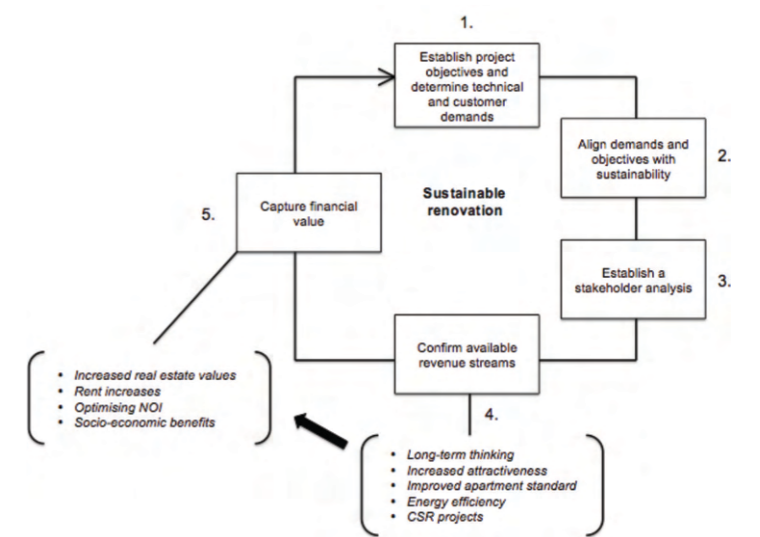

Figure 4: Suggested business model by Jonsson & Stiller

LIFE CYCLE ASSESSMENTS

Today the building industry in Sweden stands for around 20% of the country's total environmental impact. Around half of that impact is derived from maintenance, renovation and reconstruction as illustrated in figure 5 (Boverket, 2023). By supporting long term sustainable buildings with low environmental impact, the building industry has potential to be part of reaching the goal set by the government of net zero emissions by 2045 (Offentliga fastigheter, 2022).

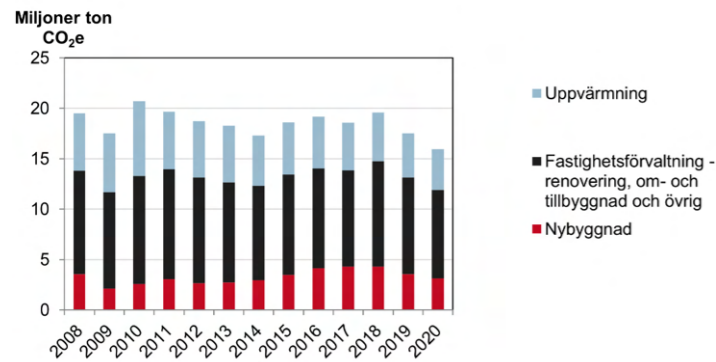

Figure 5: Division of carbon impact from the building industry

Life cycle assessments (LCA), have the capacity to include a building's climate impact over its entire life, from the construction to the maintenance of material at the end of the lifetime. By providing a quantitative result the LCA can simplify comparisons and support decisions towards lower environmental impact (Boverket, 2019).

The lifecycle

The guidelines for life cycle assessments are determined by a set of international standards. Following the EN 15978 (SIS, 2011) and the EN 15804 (SIS, 2019) standards the lifetime of a building is divided into four different phases, the building phase (A), the use phase (B), the end-of-life phase (C) and a fourth phase (D) that includes the loads and benefits beyond the system boundary. These phases are then divided further as shown in figure 10 (Offentliga bostäder, 2022).

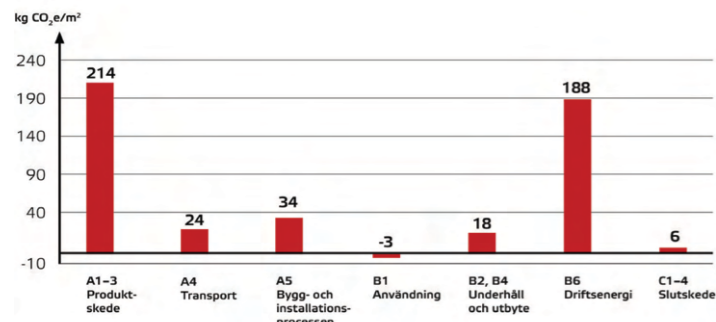

Figure 6: Typical division of climate impact (GWP) between the different life stages

The environmental impact of a building during its lifetime can be divided into embodied carbon, which is the carbon of the materials used during construction and demolition, and operational carbon which is released during the building's usage (A. Hollberg, personal communication, October 17, 2022). In early usages of LCA for residential buildings one of the main drivers were to lower the primary energy demand. As buildings overall have become more energy efficient with improved insulation, there's an increasing focus on the impact of the embodied carbon. In Sweden the focus on wooden construction together with lowering environmental impact and energy usage have been the main drivers for LCA (Beemsterboer, 2019). Figure 7 and 8 illustrates the change from the previous division of greenhouse gas emissions to the division today.

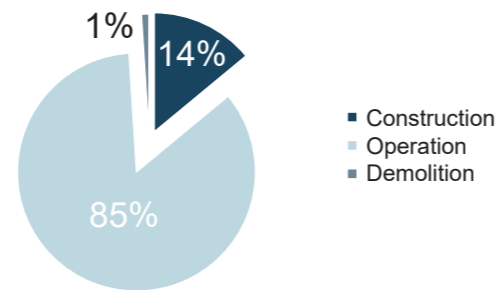

Figure 7: Previous division of greenhouse gas emission for a building

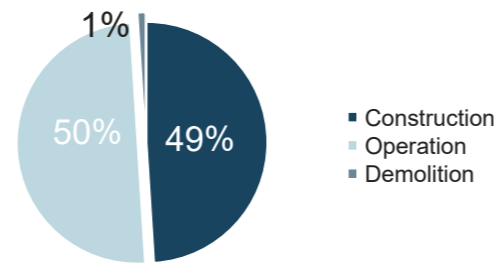

Figure 8: Division of greenhouse gas emissions for a building today

The environmental impact is commonly divided so that 45% is derived from the foundation and loadbearing structure, 30% from the façade, 15% from the roof and 10% from installations (Boverket, 2019). Since foundation and loadbearing structure often are maintained in a renovation, it is likely relevant to include the use stage in LCA for renovation cases.

LCC

Like the LCA, life cycle costs (LCC) use the same lifetime method but instead of climate impact the building's investment costs are summarized with the future costs over the building's lifetime. LCC is particularly useful for products such as buildings where a significant amount of the total costs are accumulated during its usage. The LCC can help shift the focus from reaching as low initial costs as possible and instead support a comparison between costs over a full lifetime. Together the LCA and LCC are good tools for making long term decisions with low environmental impact as well as low costs (Offentliga bostäder, 2022).

Usage and demands

In Sweden a new law became effective January 1st, 2022, introducing a climate declaration where the developer needs to provide a report of the environmental impact from the product and construction stages, A1-A5 (Offentliga byggnader, 2022). There are also demands of LCA results in environmental certifications. In Sweden, Miljöbyggnad demands performed LCA for the full lifecycle to reach the gold certification. There are also demands on LCA in the certification systems Breeam and Leed (Boverket, 2019).

While the bills of climate impact used in declarations and certifications are good for increasing the general usage of LCA, the tool is more powerful used in an early project phase. By introducing LCA early in a project the possibilities for the results to impact decisions increases while the cost for performing the changes is lower (Boverket, 2019). Using LCA and LCC for comparisons within the same project also decrease some of the demands on the simulation precision of the results since it is showing a difference rather than a life-like result.

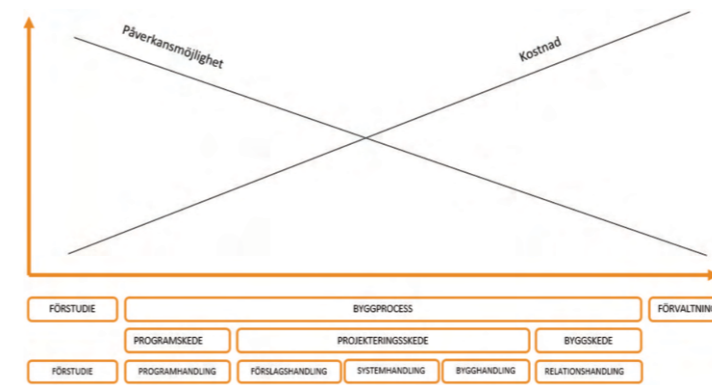

Figure 9: Diagram over impact potential in comparison to costs during a construction project

A life cycle assessment for a renovation is performed the same way it would for new production and is considered the start of a new life cycle. By excluding impact already caused by the building, reuse of already existing material is promoted which has large environmental benefits. Renovations are not yet included in the climate declaration (Boverket, 2019).

Limitations

Life cycle assessments are data intensive, and it is experienced to be difficult to find sufficient high-quality data, especially in the early design phase. There are also concerns regarding the accuracy of LCA results as there are large amounts of measured and simulated data as well as simplified modelling of complex cause-effect chains. To be able to efficiently perform life cycle assessments it is necessary to find acceptable levels of uncertainty and structures where different building options can be compared (Beemsterboer, 2019).

Beemsterboer describes different simplification methods for LCA using the logics of exclusion, data substitution, expert judgement, standardisation and automation. Very few LCA studies have been done of mobile equipment and services in a building, and focus is instead put on structure, skin and space plan. The lifetime modules can be limited to stage A1 to A3 and B6 and then expanded from there depending on the complexity of the investigation. It is also common practice to limit the climate impact category to global warming potential (GWP), which is measured in carbon dioxide equivalents. Where there's not sufficient data about the materials used, the material impact can be replaced with estimated values from databases (Beemsterboer). In Sweden Boverket has gathered the impact from different materials in an openly accessible climate database. Some products also have EPDs (environmental project declarations) where an LCA already has been performed for the specific material and impact of selected lifetime stages are presented.

Product	Construction		Use Stage							End of Life				Benefits and loads beyond the system boundary				
	A1	A2	A3	A4	A5	B1	B2	B3	B4	B5	B6	B7	C1		C2	C3	C4	D
Raw material supply																		
Transport																		
Manufacturing																		
Transport																		
Construction																		
Use																		
Maintenance																		
Repair																		
Replacement																		
Refurbishment																		
Operational energy use																		
Operational water use																		
Demolition																		
Transport																		
Waste processing																		
Disposal																		
Re-use, recovery and recycling potential																		

Figure 10: The different LCA modules, and the modules used in CAALA marked in red

Lifecycle tools and CAALA

There are many different tools in the industry for performance of LCA. In 2017 the Swedish Environmental Research Institute (IVL) released the LCA tool BM1.0 and together with the Finish OneClick LCA tool it is one of the most used tools in Sweden (Beemsterboer, 2019).

In this project, the tool CAALA (Computer-aided architectural life cycle assessment) will be used. CAALA has been developed in consideration to architectural working processes using a 3D model as the base for the investigation. In CAALA it is also possible to simultaneously run both LCA and LCC. The simulations in CAALA can include the lifecycle phases A1 to A3, B4, B6, C3 and C4 as marked in figure 10 which makes it possible to investigate both the embodied and operational impact of the building. Phase D can also be included but has in this project been removed to limit the study.

CAALA takes in a 3D model of the investigated building where all building parts are represented by 2-dimensional surfaces. Each surface in the model is given a layer depending on their function, such as windows, internal walls, wall to ground and so on. Building parts on the A-layers have thermal properties while the building parts on the B-layers don't and therefore won't impact the model's energy usage. Each layer gets materials assigned through either premade or customised components. The building materials retrieve the environmental impact from the standardised German database Ökobaudat and it is not possible to change the embodied impact manually. To solve this the materials used

in the simulations will be matched as close as possible to values from Boverket or EPDs. When the materials have been selected, they can be given adjusted U-values and lifespans. The climate zones available in CAALA are also limited to areas in Germany, in this project the zone will be set to the climate of Hof since it has a similar climate to Gothenburg.

It is also possible to adjust the technical equipment in CAALA and global warming potential from for example district heating can be set manually, which makes it easy to adjust it to local values. Project specific values for hot water demand, user electricity and ventilation system can also be added.

For comparison of lifecycle costs the program utilizes manually added investment costs for the new building parts. It also takes in manually added percentages of change per year in energy and building costs as a prediction of future costs. Costs for maintenance and repair are calculated in CAALA using a percentage from the added investment cost for an exponential increase per year for the building part. For building parts the values are 0.1% for maintenance and 0.35% for repair. For technical equipment the values are 0.41% for maintenance and 0.66% for repair (Johansson, 2021). The cost unit is automatically set to euro. CAALA provides resulting environmental impact with different units, but in this project the result for global warming potential and primary energy demand will be used.

FUTURE ENERGY AND BUILDING COSTS

Rate of increase, energy costs

To estimate accurate future energy costs a method presented in a previous master thesis by Emanuel Johansson (2021) has been used. The method was provided by a professional from the Swedish Energy Agency. The final values calculated here have also been compared values from previous LCC calculations to make sure they are in a similar range. It is however very difficult to get an accurate prediction of the future since energy costs can fluctuate a lot and are dependent on unpredictable factors.

The impact on energy prizes can be derived from three sources, the power distribution grid, the energy prize (which is the deal with the energy company) and the energy tax (which has been set by the government). Sweden is also divided into different energy zones with different costs for energy. Gothenburg is part of zone 3.

Since what we want to use in CAALA is a percentual change of cost per year we can calculate the future costs using the exponential function:

Estimated price now * Increase rate ^ Number of years = Estimated price in the future

Power distribution grid

For the calculation of future power distribution grid costs, Statistics Sweden (SCB, 2023) has a dataset with previous power distribution costs in Sweden from 1996 and onwards. In this case the cost change from 25 years back until now was calculated to estimate a future cost. The cost for the power distribution grid for apartments was in 1997 41.1 SEK/kWh and in 2022 84.3 SEK/kWh (SCB, 2022). For these costs to be comparable they need to be adjusted for inflation. By using the consumer prize index (CPI) the inflation rate from 1997 to 2022 can be calculated and the value from 1997 increased. Now a prediction for the future cost can be calculated as shown below.

Price 1997: 41.1 SEK/kWh
 Price 2022: 84.3 SEK/kWh
 KPI 1997: 257.38 KPI 2022: 370.95
 $\frac{370.95}{257.38} \approx 1.44 \rightarrow$ Increase with 44%
 Price 1997 without inflation: $41.1 \cdot 1.44 \approx 59.24$
 Exponential function for cost increase/year:
 $59.24 \cdot x^{25} = 84.3 \Rightarrow x \approx 1.014$

The percentual increase per year of the power distribution grid can be estimated to 1.4%.

Energy prize

For calculation of the future energy price, values from a report from the Swedish Energy Agency (2023) has been used. The values presented in the report were an average of all energy zones so here the increase rate has been assumed to be the same for zone 3 as for the average. The price in 2020 was ca 0.22 SEK/kWh and in 2050 it was estimated to be ca 0.56 SEK/kWh. No adjustment for inflation has been done. Using the same calculation as for the power distribution grid the new energy prize can be calculated.

Price 2020: 0.22 SEK/kWh
 Price 2050: 0.56 SEK/kWh
 Exponential function for cost increase/year:
 $0.22 \cdot x^{30} = 0.56 \Rightarrow x \approx 3.16$

The percentual increase per year of the energy prize can be estimated to 3.16%.

Energy tax

The energy tax is unchanged in real terms (without impact from inflation), so it is here estimated to be 0%.

Total price increase rate:

The values presented above can be assumed to be around 30% each of the total prize increase. In total the increase rate for energy becomes $(1.4 + 3.16 + 0) / 3 =$ ca 1.5%. This is the cost increase without any impact from inflation.

This means that the initial costs will increase with 1.5% yearly. The initial cost for district heating in 2023 has been taken from Göteborg Energi and is set to 0.675 SEK/kWh (or 0.06 Euro/ kWh in CAALA) and the initial cost from for electricity is the average cost from Nord Pool's spot prizes for 2022 and is set to 1.37 SEK/kWh (0.12 Euro/ kWh).

Rate of increase, construction costs

To estimate the future construction costs the construction cost index (CCI) has been used as provided in the CCI database by Statistics Sweden (2022). Since the database contained a rate of change already, an average was calculated from year 1997 to 2022. This gave a percentual increase of construction costs of 3.4% per year.

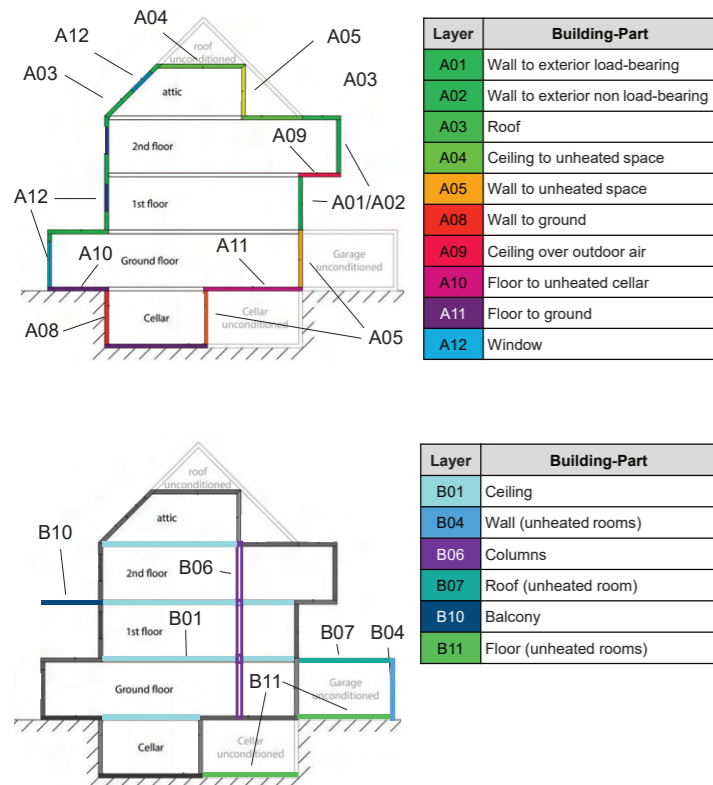
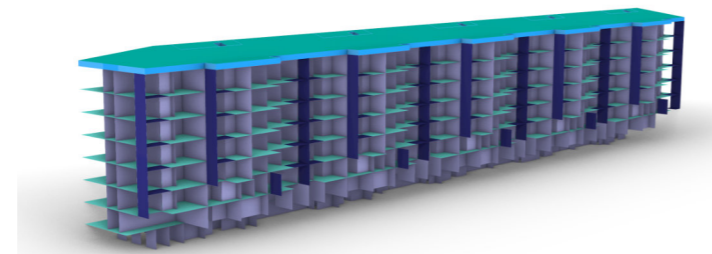
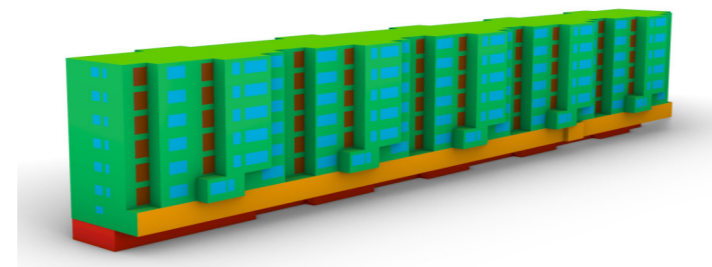

Figure 11 & 12: CAALA layers for the preliminary planning phase



CAALA layers of the investigated building model (original unrenovated building)

RENOVATION EXAMPLES

Example 1 - Solhusen in Gårdsten

Architect: Christer Nordström Arkitektkontor

Location: Gothenburg, Sweden

Original construction date: 1969-1972

Renovation date: 1998

About

Gårdsten is a million-program area in Gothenburg and like Gårdsås it was built in the early 70s. In 1998 the buildings were in large need of renovation and construction was initiated. The project contains two yards with concrete buildings of two types, so called "loftgångshus" with external corridors and low-rise lamella buildings. Part of the management assignment in the area was to provide a plan for positive development of the standard of living, something that was done in close collaboration with the residents in the area (Gårdstensbostäder).

Economy

One aim of the housing company in the area was to maintain low rents as well as improve the resident's control over their own expenses. Part of this goal was achieved by installing individual measurement of electricity, water usage and heating. In one area the residents took over some of the yard responsibilities to lower the caretaking costs, but also to get control of the selected plantation.

By reducing the number of stages in the construction process the production costs could be decreased, which at the second project area reduced costs by 20 million SEK. Due to the combination of renovation and usage of solar energy, the project was also able to be part of two different EU projects. While the participation demanded more thorough feasibility studies and increased the demands on technique and architecture, parts of the costs was covered by support from EU (Gårdstensbostäder).



Figure 14: Overview of the area



Figure 15 & 16: The building facades before and after the renovation

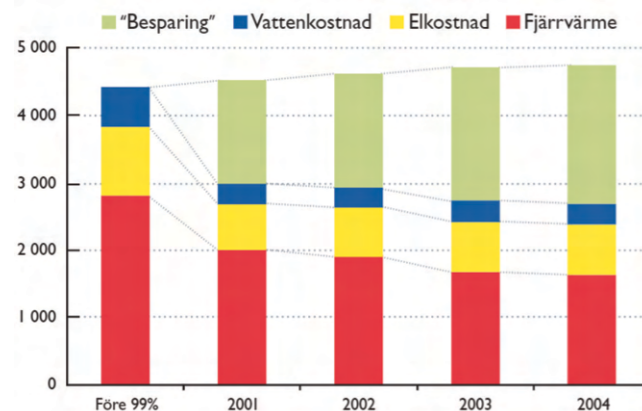

Figure 13: Reduction of operational costs

Environment

There were several different measures performed to reduce the environmental impact of the buildings in Gårdsten. The exhaust air ventilation system was improved and in some buildings heat recovery ventilation was installed. Solar collectors were installed on one of the roofs connected to an accumulator tank in the basement providing the area with heated water. On the lamella buildings solar air collectors were installed on the southern façades. The air gets heated and is then circulated by a fan between a new façade wall and the original construction on at the northern, eastern, and western façades.

By glazing the balconies and external corridors ventilation air can be preheated in the spring and autumn when sunlight hits the balconies. The glazing also protects the façades and lowers the transmittance heat losses. Other passive energy saving measures included exchanging the inner windowpane of the 2-pane windows to a low-emission version and increased insulation by the roofs and gables. Insulation was also added to the building base in connection to the renovation of drainage pipes.

To improve the energy saving further there were new kitchen appliances and laundry machines installed together with a new central surveillance system (Gårdstensbostäder).

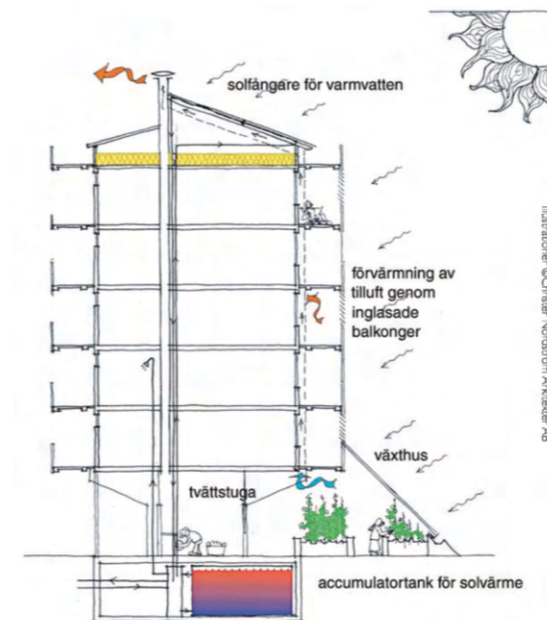

Figure 17: Connection between the solar collectors and the accumulator tank

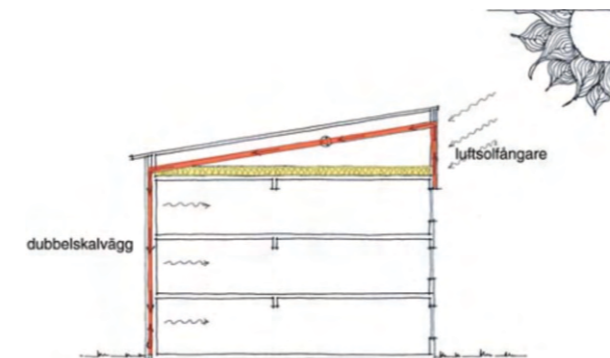

Figure 18: Heating system with solar air collectors and double walls

Architectural qualities

After discussion with tenants, the open entrance floors were glazed and used as greenhouses connected to common spaces and laundry rooms. The façades were painted in brighter façade colours as the initial grey of the concrete was looked upon negatively by many. Renovation of entrances and staircases was also done.

The visibility over the yard from the laundry rooms was one of the factors important to the tenants, as well as the creation of playgrounds for small children. Through the engagement of tenants, the common spaces got adapted to different activities such as playing rooms for children (Gårdstensbostäder).



Figure 19: View of the greenhouse

Adaption to Gårdsås

The areas of Gårdsten and Gårdsås have similar climate conditions which makes it possible to test similar passive energy saving measurements in Gårdsås. There are also similar social conditions but as there have been several interviews with tenants done in Gårdsås, those should be prioritised.

As outdoor spaces for the previous renovations in Gårdsås have been economically supported by the municipality, it has been one of the areas where much development has been possible to perform without high costs. However, leaving garden areas for tenants to appropriate could be a way to decrease the maintenance costs over time.

The entrances at Siriusgatan today receive little sunlight due to their deep position in the building but could potentially be made into well-lit common areas if the garage is removed or if some of the older apartments can be replaced with new construction. Today there are also no accessible common rooms in the building.

Example 2 - Block G, H, I

Architects: Lacaton & Vassal, Frédéric Druot, Christophe Hutin architecture
Location: Bordeaux, France
Original construction date: 1969-1972

About

In France as well as in the rest of Europe, many post-war buildings were constructed during the 60s and 70s to relieve a pressing need for increased housing. Today, like the million-program areas, they need renovation. The plus strategy is a method developed by Frédéric Druot, Anne Lacaton and Jean Phillippe Vassal to target this issue and was used to develop the Block G, H, I project. The strategy argues for a movement away from demolition of modernist building blocks by instead transforming and adding to them, improving their qualities.

In the Block G, H, I project, three inhabited social housing buildings in Bordeaux were renovated as part of a larger renovation scheme in the city. The buildings were constructed in the early 60s and together contain 530 apartments (Lacaton & Vasall, 2017).

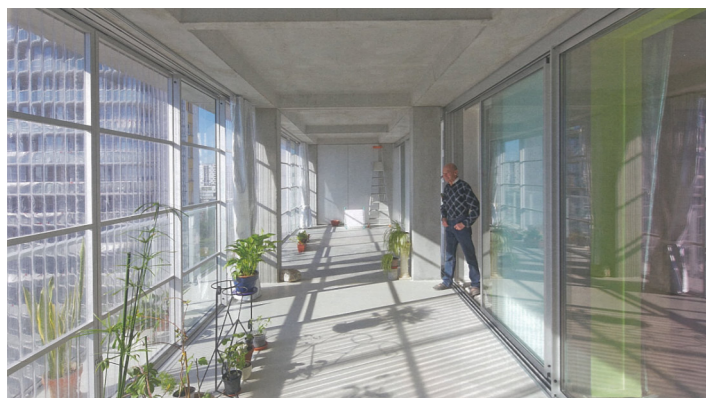

Figure 20: Space created by the winter garden



Figure 21: The new facade

Economy

As much of the building structure was in good shape, the project was able to save a large amount of costs by preserving the existing building and making as little interventions to the structure, floors and stairs as possible. The economic assets could then instead be focused on the building extensions added to the facades. Since the renovation was focused on the façade, residents were able to remain in their apartments during the renovation, which removed the costs needed for repositions (Lacaton & Vasall, 2017).

The winter gardens are made from pre-casted concrete modules that could be added directly onto the façade. The efficient construction method as well as experience from similar strategies at previous projects made it possible to perform the external renovation in 12-16 days for each of the apartments and led to low construction costs (Slessor, 2019).

Environment

To decrease the heating demand, insulation was added to the northern facades on two of the blocks as well as new double-glazed windows with automatic shutters. By adding the insulation on the outside of the building the need to enter the apartments was avoided. On the southern, eastern and western facades the winter gardens were added which also has an insulating effect acting as a heat buffer before the façade. All together the building's energy usage was lowered with ca 60%.

The concrete walls underneath the windows by the southern facades were removed and replaced with sliding glass doors and thermal curtains were placed to provide extra insulation. The outer shell of the winter gardens was also provided with reflective solar curtains to help combat overheating.

Apart from the winter gardens there was an upgrade of the electricity system and internal renovations of the bathrooms. The natural ventilation system got improved by adding new ducts as well as mechanical assistance (Slessor, 2019).

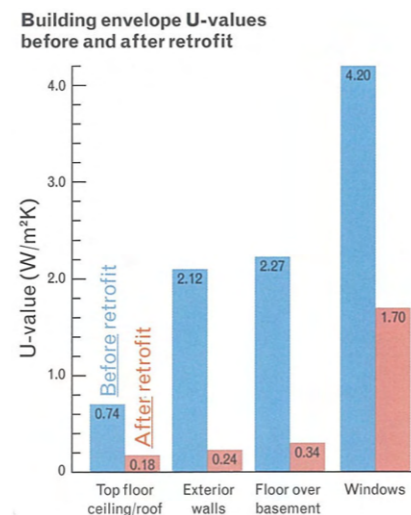

Figure 22: Reduction of U-values after renovation

Architectural qualities

The addition of winter gardens increases the amount of usable space in the apartments, as well as the access to natural light. By opening the concrete façade by the original windows, the daylight is allowed to reach further into the apartments. The position of the building and surrounding areas also provides access to extensive views.

The balcony railing is made of glass and the external sliding partitions of the winter garden is made of one third glass and two thirds translucent polycarbonate panels. By the original façade another sliding position in glass has been added together with the thermal curtains. Together with the reflective curtains by the outer shell these different layers make it possible for the residents to adjust the space's size, privacy and connection to the outside and increases the possibilities of usage. While not at all reflecting the original building design, the transparent façade material allows the residents to appropriate their own section of the façade, giving it a unique expression (Slessor, 2019).

Adaption to Gärdås

To demolish the buildings in Gärdås is currently not a discussed alternative to the renovations, and the economic gain from keeping the original structure doesn't make sense to compare in this specific project perspective. However, it would be interesting to compare the economic impact from a demolition to that of a renovation for a more general reflection on cases where it is a more viable option.

The climate in Sweden differs from that in Bordeaux with less sunlight and colder temperatures. To be able to utilise passive solar heating from the glazed balconies they need to have access to direct sun and are dependent on the direction they are facing. The glazed areas should also have high performing glass and some of the walls might need increased thermal mass for heat storage. While glazed extensions are likely not beneficial to the same extent as in Block G, H, I, it would still be interesting to investigate the possibilities to extend the current living spaces using balconies in Gärdås as there is both occurrence of overcrowding and potential for great views.

Buildings H,I - climbs 1,3 and 5 - current floor

	existing	transformed	surface created		existing	transformed	surface created		existing	transformed	surface created
T5				T3a				T4			
living space	81.00 m ²	86.00 m ²	+5.00 m ²	living space	56.50 m ²	59.00 m ²	+3.50 m ²	living space	67.00 m ²	73.00 m ²	+6.00 m ²
winter garden	-	26.00 m ²	+26.00 m ²	winter garden	-	44.00 m ²	+44.00 m ²	winter garden	-	18.00 m ²	+18.00 m ²
usable area	87.40 m ²	122.50 m ²	+35.10 m ²	usable area	58.50 m ²	119.10 m ²	+60.50 m ²	usable area	73.40 m ²	98.70 m ²	+25.30 m ²
balcony	4.30 m ²	8.40 m ²	+4.10 m ²	balcony	-	14.00 m ²	+14.00 m ²	balcony	4.30 m ²	5.60 m ²	+1.30 m ²

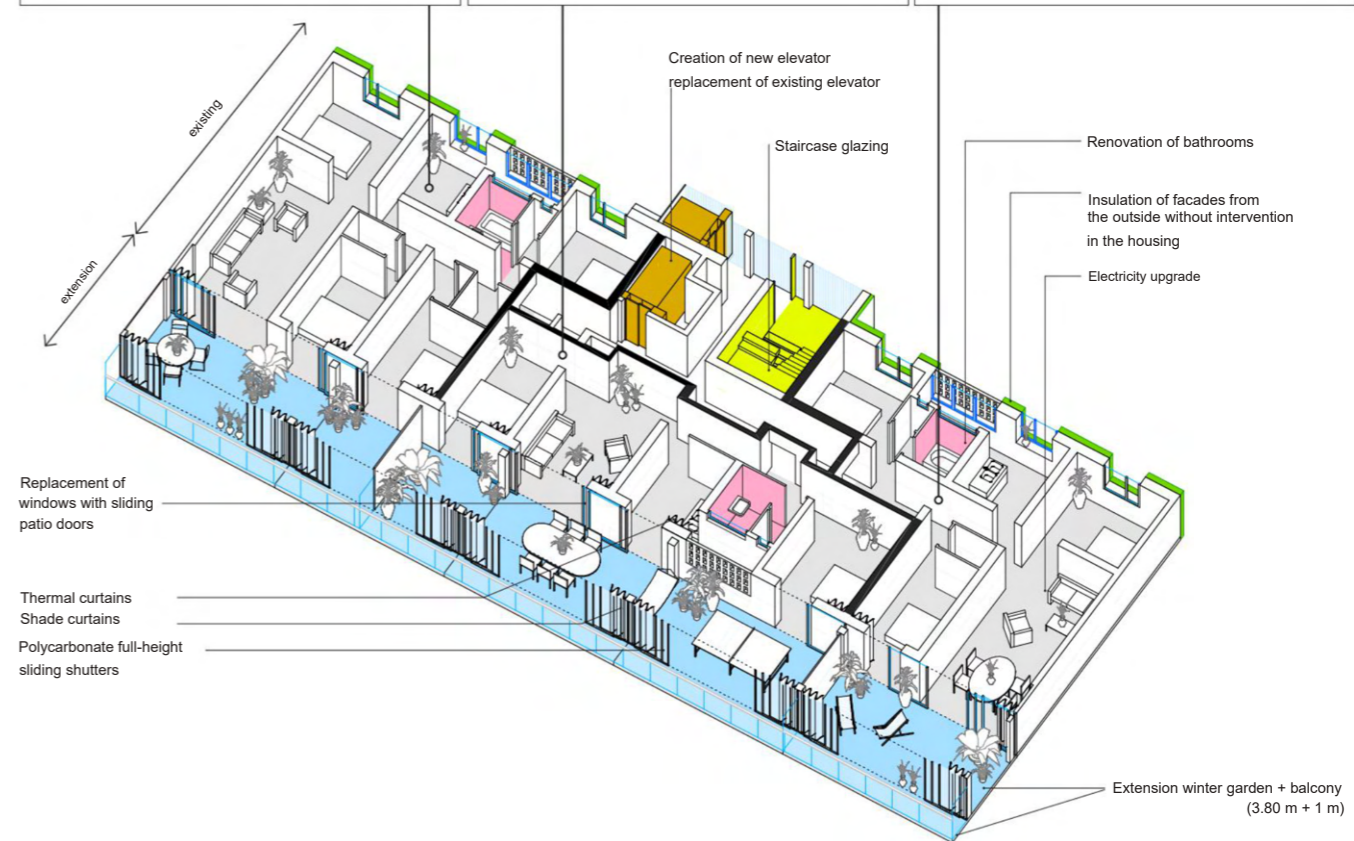

Figure 23: Floor description building H & I

Example 3 - De Flat Kleiburg

Architects: NL Architects, XVW architectuur
Location: Amsterdam-Zuidoost, The Netherlands
Original construction date: 1968-1975
Renovation date: 2012

About

The Kleiburg building is part of the Bijlmermeer area in Amsterdam which was a modernist project in the 1960s-70s to improve the Dutch housing standard, similar to the million-program movement in Sweden. 25 buildings were constructed that together were able to house 100 000 people - almost all with the same typology. The building was planned to be demolished with a new building replacing it, but due to the banking crisis the project lost its profitability and the demolition got halted. To find an alternative project strategy, a competition was held where the winning idea suggested making the building into a Klusflat (from the Dutch word "klussen" which means "to do it yourself") where the apartments were stripped and sold empty (K. Klaase, personal communication, November 18, 2022).

Economy

As only public areas of the building were renovated, and the interior of the apartments was left for the new habitant, the renovation got less expensive for the building owner. Since one of the companies in the development group was a large contractor, they were able to cover the initial costs. If not for the banking crisis and the fact that there wasn't anything else for the contractor company to do, the building likely would not have been renovated in the way it was - it took very specific conditions (Klaase, 2022).



Figure 25: The original area



Figure 24: Building entrance and facade

Architectural qualities

The architect's idea was to keep as much of the original design concept as possible and only make small changes to the existing structure.

Storage spaces were moved to the core of the building to free up space from the ground floor. The freed space was then filled with apartments and businesses, creating a more friendly meeting between the building and the outside. The external elevators were moved to the inside and the original concrete facade was re-brought to the surface, bringing back the original façade expression.

The apartments were stripped of all non-loadbearing walls and appliances. The opaque parts of the apartment facades were replaced with double glazing and a catalogue of window placements for habitants to choose between were presented. Extra breakthroughs between apartments made it possible to connect them both horizontally and vertically.

Adaption to Gärdås

Since the apartments of the DeFlat project got transformed into condominiums a similar internal renovation is not a feasible option in Gärdås. However, the creation of catalogue options could be an interesting way of increasing the tenant influence over the renovation, in particular if the different options also entail different costs.

The overall strategy to bring back the original vision of the architects is something that could potentially be applied in Gärdås as well if the quality of the original building allows it. Reconfiguring of functions to provide a friendlier meeting with the street would also be interesting to investigate, in particular if the underground garage were to be removed since it would open up new potential solutions for entrances and activities facing the yard.

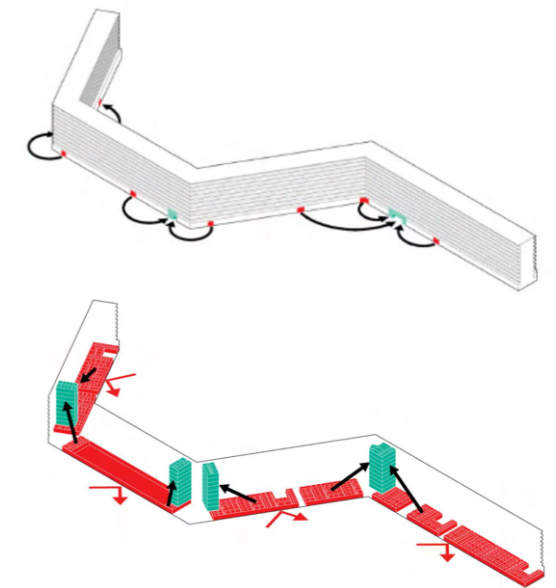

Figure 26 & 27: Movement of entrances and storage spaces

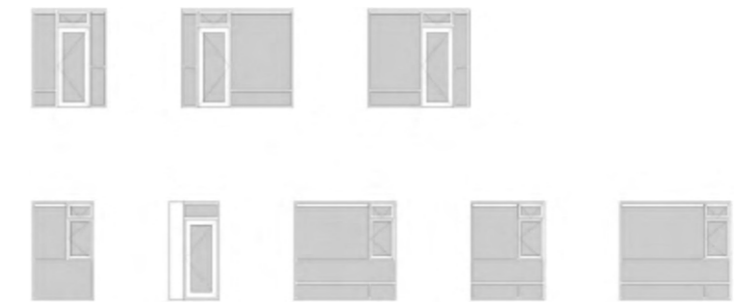

Figure 28: Facade modules



Figure 29: New entrance

CASE STUDY

THE SITE

Area background

The investigation in this project focuses on the renovation of an apartment building in Gärdsås which is located northeast of central Gothenburg in western Bergsjön. The building was constructed in 1970 together with 11 other building in the same area and in total there are ca 1200 apartments. Today the buildings need to be renovated and in 2019 renovation of the facades was initiated on a first group of buildings. During the external renovation it was discovered that the inside of the apartments needed to be renovated as well due to issues with fouling. Further renovations are planned for the finished buildings and renovations with both external and internal measures are planned for the non-renovated buildings.

In total the area has around 3040 residents and compared to other areas in Sweden there is a large percentage of children. The area has an issue with overcrowding that has led to increased tear of the interior of the apartments. The average income in the area is one of the lowest in Gothenburg and high increases in rent should be avoided (Hamon et al., 2016).

Why this building?

Due to the renovation project's focus on maintaining low costs and the potential of reduced environmental impact from a renovation of the climate shell, the building is an interesting project for performance of LCC and LCA and investigation of their possible impact. The previously performed renovations in the area will also help the collection of data for the life cycle assessments. Since the buildings have very similar design, it can be assumed that similar measures will be performed. The investigated building is one of the buildings that in the future will need both external and internal renovations, and there is room for suggesting changes to the full building. The investigated building also only contains apartments which simplifies the simulations and calculations of cost.

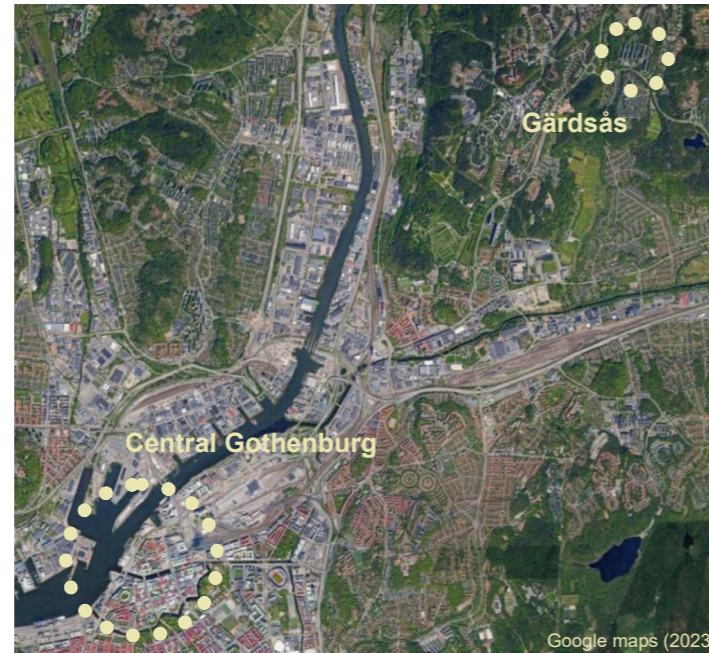

Gärdsås in relation to Central Gothenburg

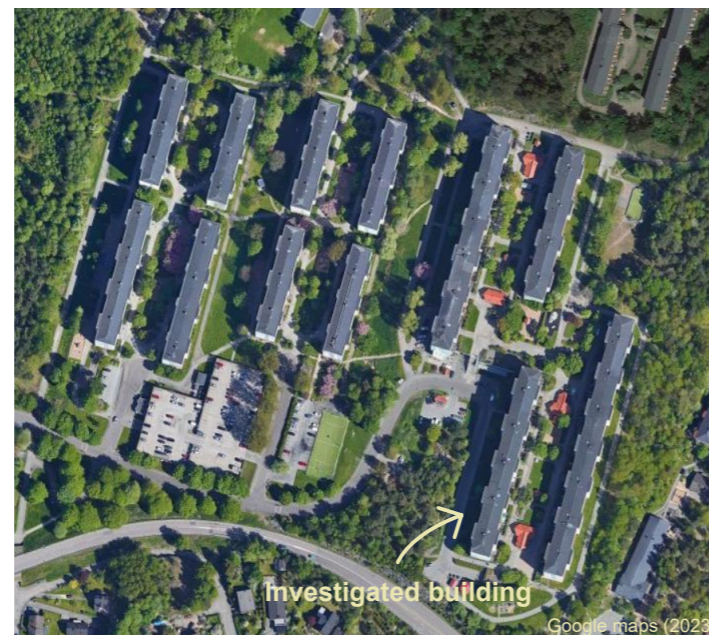

The full housing area in Gärdsås

Surrounding area

The investigated building is located on the highest point of the housing area. To the west there is a steep hill where there are plans for future housing which will be discussed further later in this thesis. There are also two bus stops along the road to the west of the building and it is close to the office of Familjebostäder, making the stairs and roads west of the building one of the area's main entrances. The inner yards are located on top of a garage building which creates a height difference between the building entrances and the surrounding area.



- Investigated building
- Staircases to the garage
- Familjebostäder office
- Planned housing
- Garbage disposal
- Laundry rooms
- Bus stops

Site visit

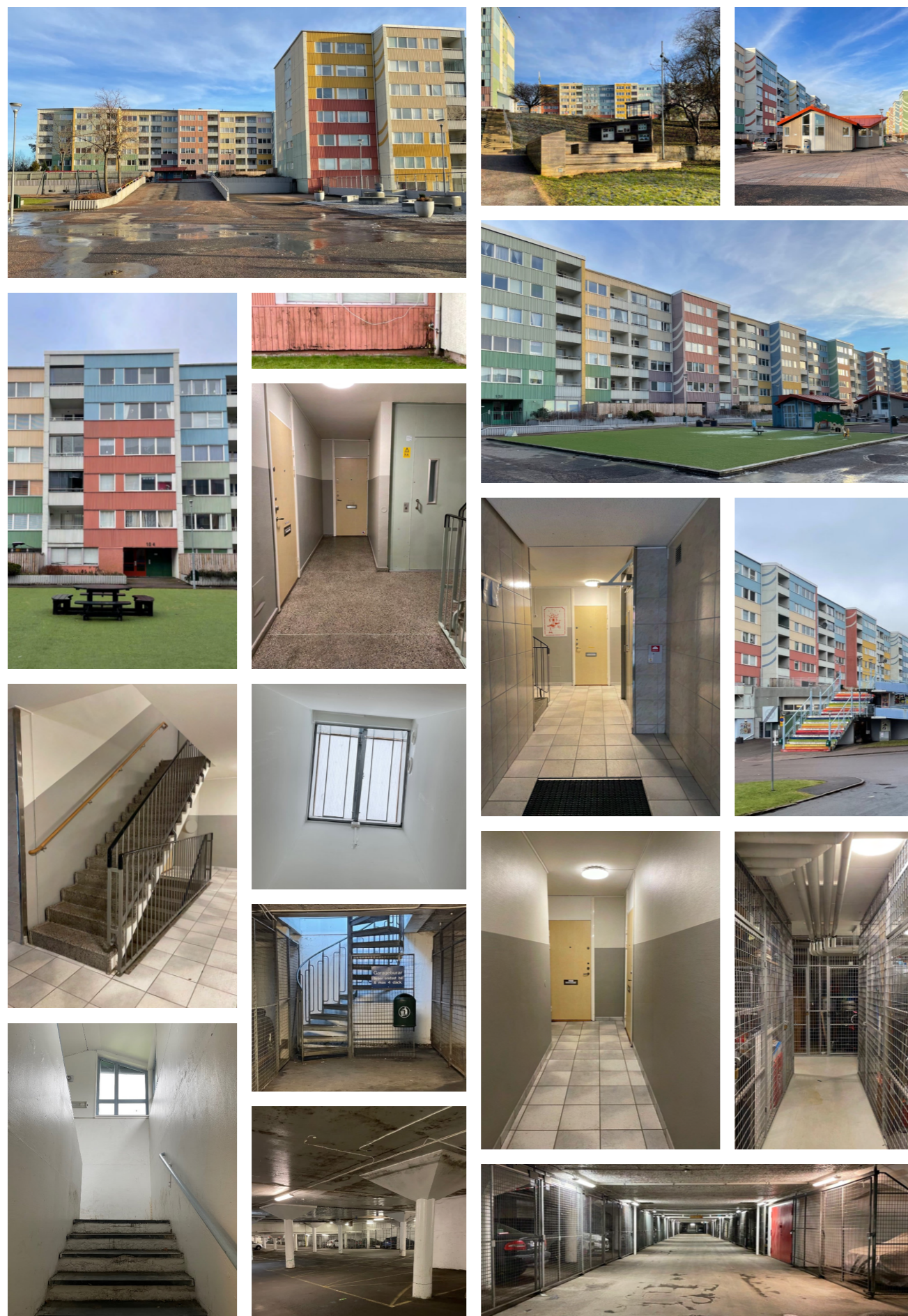

TENANT INTERVIEWS

Already in 2012-2013 it was evident that the buildings at Siriusgatan needed technical renovation. At the same time a process to improve the attractiveness of the area was initiated, with the development of a new detail plan. The third part of the development process was the involvement of residents. The plans have since then changed and are still in development but as many of the suggested measures remains, the collected information from the tenant interviews is to a large extent still relevant.

The dialogue process with residents was properly started in 2017 after an initial meeting with the tenant's union in 2016. The dialogue was divided into three steps: discussion in an open pavilion, round table discussions and lastly discussion in focus groups. The main goals defined by Familjebostäder for the area was to reach safety, well-being, attractiveness, welfare and increased belonging (Femenias et al., 2018).

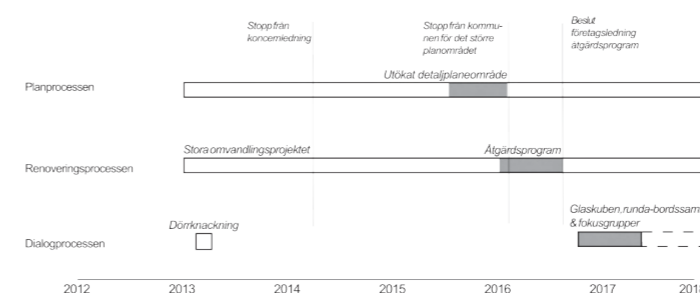

Figure 30: Timeline over the different processes at Siriusgatan, the areas marked in grey were part of the research project where the interviews were studied

The pavilion

As initial contact with the residents a temporary pavilion was placed one week on a nearby square and was later moved to the housing area. With the pavilion around 500 people were reached, of which 100 agreed to join the next step. The housing company asked open questions regarding the renovation, detail plan, façades, outdoor areas, and also general happiness/discontent with the area. The two main topics brought up were the colours of the facades as well as maintenance of the outdoor areas. Overall, there were a large interest among residents of their area (Femenias et al., 2018).

There was in general a positive attitude towards the renovations, many were happy with the restricted extent of the renovation without included kitchens and bathrooms. Some residents expressed worry for increased rents. There was a positive reaction to new windows, and many wanted new blinds. Regarding the colour of the houses there were split opinions where some argued that they create an identity in the area and that the new colours were better than the original colours. There were no clear opinions on outdoor areas, some suggested more meeting places and playgrounds as well as increased lighting for safety.

Most people saw the new production as something positive and approved of the low-rise terraced houses. Having different forms of tenure was also considered positive. Some of the worries expressed were high-rise buildings removing the views and removal of green areas. There were also worries of the parking being removed as well as increased car traffic through the area (Jaxmark, 2017).

Round-table discussions

In groups of around 30, the residents discussed 4 selected themes that had been brought up during the discussion at the pavilion: safety, culture, activities and the proposal to change the name of the area (Femenias et al., 2018).

Focus groups

In total 5 groups with less people discussed in depth a proposed renovation proposal. Separate groups were made for youths and women.

Two topics appeared more important to tenants, the colouring of the facades which was connected to the identity of the area as well as the possibility to see and recognize your neighbours in the outdoor area in relation to safety. Another topic discussed was the possibility to choose privacy using terraces and balconies (Femenias et al., 2018).

Market survey

Apart from the interviews made by Familjebostäder, there have also been a market survey made by Industrifakta where 200 of the 1450 households were interviewed. The survey showed that a large amount of the residents wanted to be able to impact the level of renovation (80% compared to the average 50%) and there was in general a large interest in the housing development in the area. It was also revealed that the tenants gave high priority to improve indoor climate, which differs from the usual prioritization of improved bathrooms and kitchen appliances (Hamon et al., 2016).

Factors to consider further in the project:

- Creation of identity
- Safety and lines of vision
- Preservation of green areas
- Accessibility
- Indoor climate

BUILDING TIMELINE

1970 - 1971 Excavation & construction

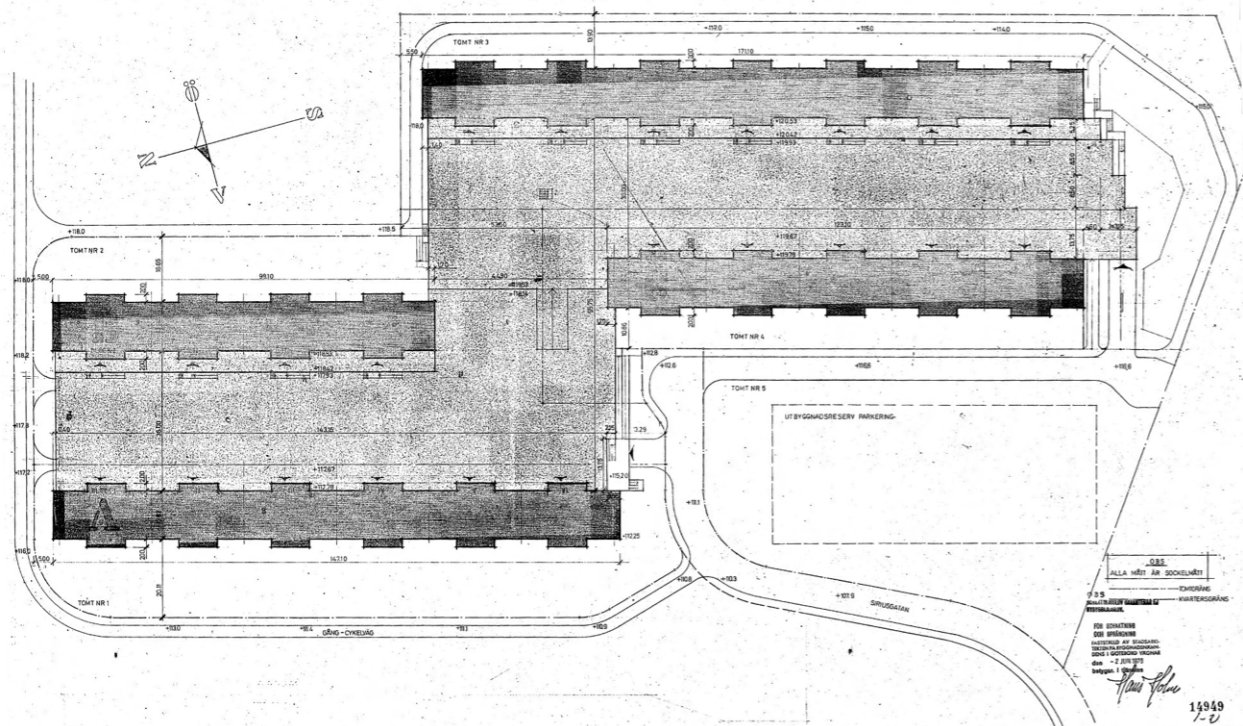

1972 Installment of water and sewage systems

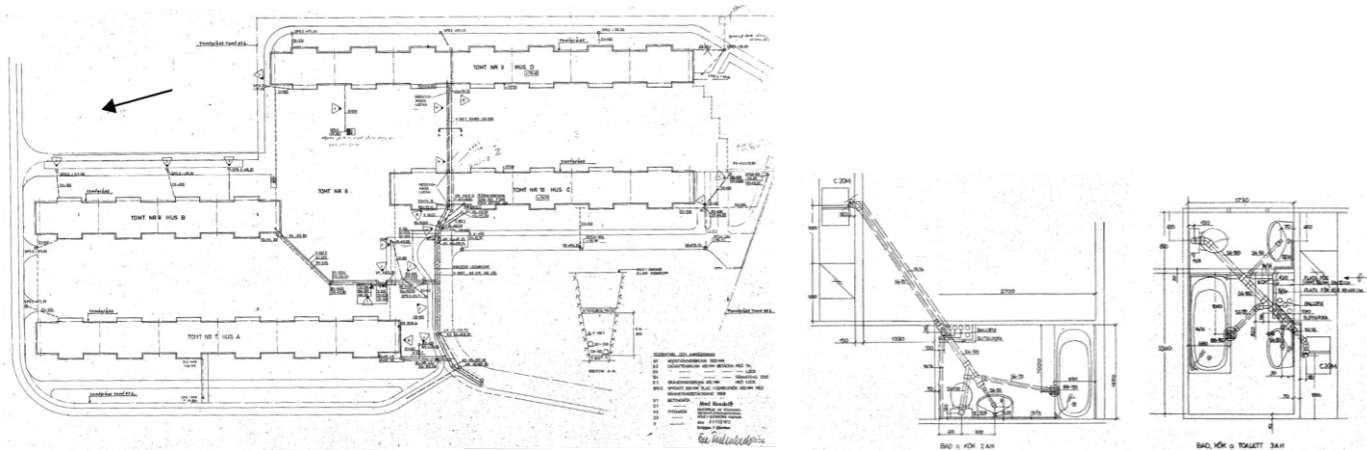

1989 Reconstruction from garage to dressing room

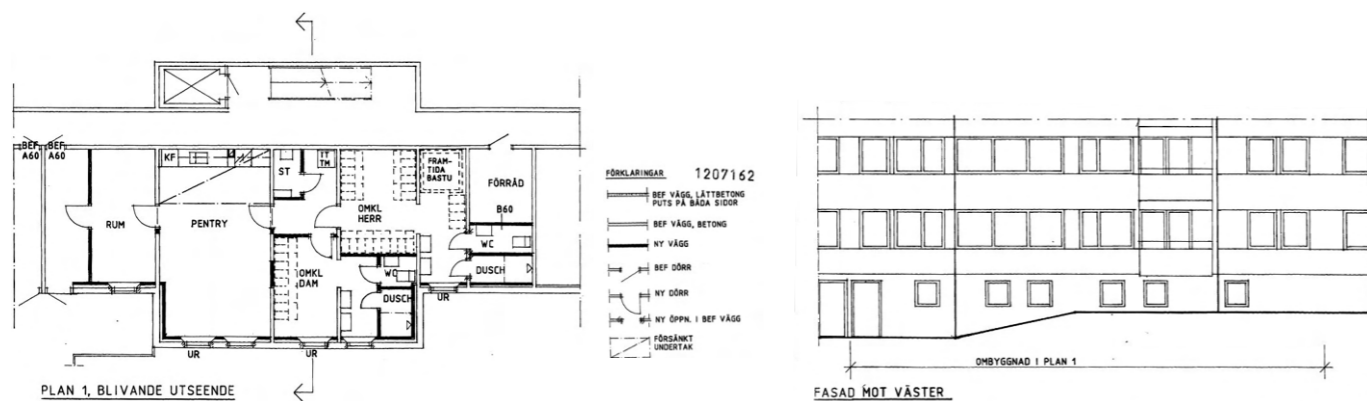

1993 New facade layers



1994 Removal of entrances to common garage

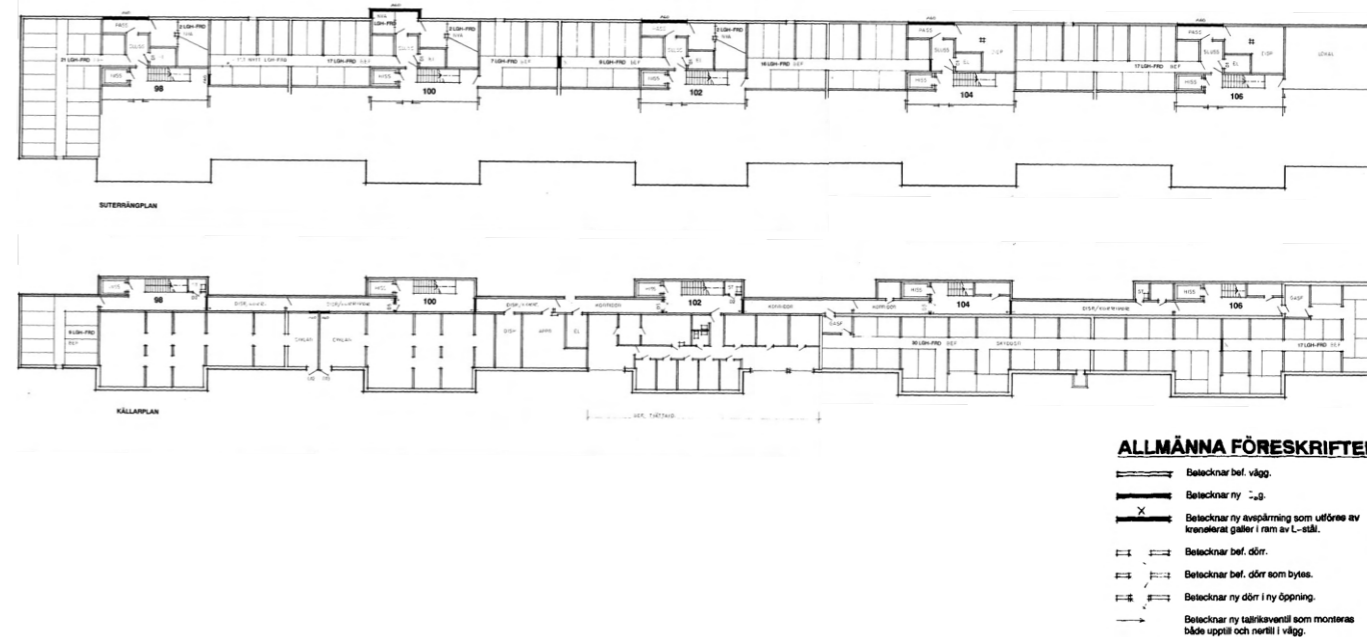

2027 Planned renovation of facades and bathrooms

ORIGINAL FLOORPLANS

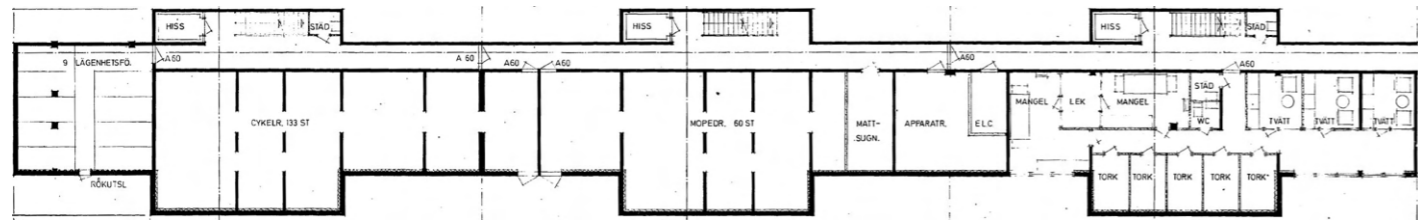

Basement floor

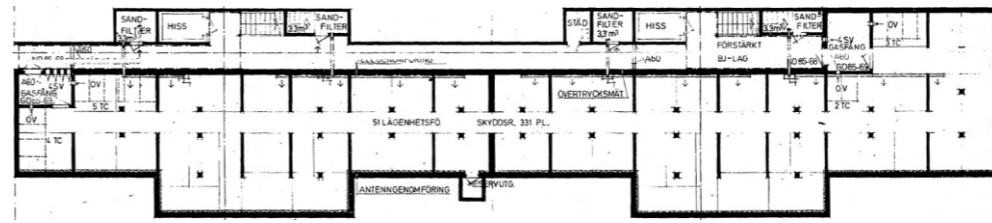

Souterrain floor



Entrance floor



Floor 1-5



- 1-room apartments
- 2-room apartments
- 3-room apartments

BUILDING INFORMATION

Measurements

Gross floor area, GFA: 12270m²

Gross housing area, BOA: 9067m²

Heated area, Atemp: 11640m² (basements heated, attics unheated)

Amount of apartments: 146 (25 1-room apartments, 66 2-room apartments, 48 3-room apartments)

Economy

Level of rent: 810 SEK/m²

Operational costs: 488 SEK/m² (company average is 431 SEK/m²)

Net operating income: 122 SEK/m² (company average is 277 SEK/m²)

38:3 hus 1601
Siriusgatan 16-22
247 hyresgäster, 92 lägenheter

38:2 hus 1602
Siriusgatan 24-28
176 hyresgäster, 71 lägenheter

38:5 hus 1603
Siriusgatan 30-36
280 hyresgäster, 96 lägenheter

38:4 hus 1604
Siriusgatan 38-42
185 hyresgäster, 72 lägenheter

38:7 hus 1607
Siriusgatan 54-58
167 hyresgäster, 67 lägenheter

38:6 hus 1608
Siriusgatan 60-64
167 hyresgäster, 69 lägenheter

38:9 hus 1605
Siriusgatan 66-70
187 hyresgäster, 72 lägenheter

38:8 hus 1606
Siriusgatan 72-76
197 hyresgäster, 72 lägenheter

Investigated building

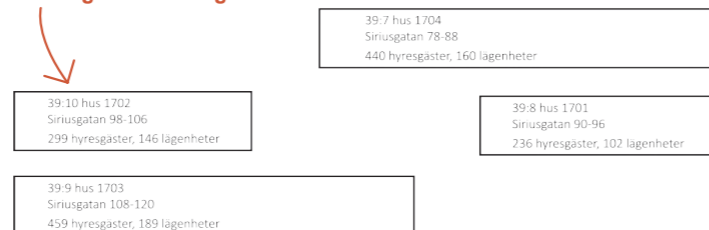

Figure 31: Apartment buildings with amount of residents and apartments

RENOVATION COSTS

The following project costs are adjustments of the previous renovation costs as applied to the investigated building and should be considered rough estimations. The costs are assumed to be including working hours and excluding VAT. Some of the costs added might not be needed in the investigated building, for example the cost for drainage and the additional road to the garbage disposals. The costs

shown here and in the following parts of the report are a combination of costs provided by Familjebostäder, the entrepreneur, production companies and costs calculated using Wikells Sektionsfakta (2023).

External renovation costs

	Project costs	Proportion
Facade	16 340 000 SEK	22%
Roof	1 810 000 SEK	2%
Windows	17 250 000 SEK	23%
Balconies	3 640 000 + 4 540 000 SEK	11%
New yard buildings	8 180 000 SEK	11%
Yard installations	15 440 000 SEK	21%
Project developer	7 260 000 SEK	10%
Total:	74 470 000 SEK	

External renovation measures

Facade	Demolition, sanitation, added insulation & facade materials, new entrances
Roof	New surface material, improved roof safety, added insulation & smoke hatches
Windows	New windows and balcony doors, connected asbestos removal by windows
Balconies	Strengthening of concrete, new railings, glazing as an additional choice (in total 70% of the balconies were glazed)
New yard buildings	New buildings for laundry and garbage disposal, added road for garbage gathering
Yard installations	Water installations, outdoor environment improvements, new paths, drainage

Total increase in rent after renovation 14-19%

Rent before renovation, 3-room apartment 80m²: 5480 SEK/month

Rent after renovation, 3-room apartment 80m²: 6260 SEK/month (excluding optional additions)

Rent after renovation, 3-room apartment 80m²: 6530 SEK/month (including optional additions)

Internal renovation costs

	Project costs	Proportion
Bathrooms	44 490 000 SEK	63%
Main drains	2 720 000 SEK	4%
Heating system	5 450 000 SEK	8%
Electricity	6 360 000 SEK	9%
Additional choices	11 810 000 SEK	16%
Total:	70 820 000	

Internal renovation measures

Bathrooms	Pipe replacement, renovation of surfaces, additional WC or storage space, improved accessibility, new location of bathtub/shower
Main drains	Exchange or relining
Heating system	Exchange from 1-pipe to 2-pipe system
Electricity	Apartment fuse boxes exchanged to automatic fuses
Additional choices	New kitchen, parquet, interior doors, wardrobe

Total increase in rent after renovation 12%, 20% of apartments left without rent increase

Rent before renovation, 3-room apartment 80m²: 5480 SEK/month

Rent after renovation, 3-room apartment 80m²: 7040 SEK/month (excluding optional additions)



View over yard and building in the area

EXTERNAL RENOVATION MEASURES

The technical report from the investigation before the external renovation revealed that the buildings in the area had issues with large leakages of heat concentrated around the windows and by the connections between the façade and the concrete structure. The walls both had a low amount of initial insulation and the existing insulation had partially caved in, resulting in low insulating properties of the walls. In the renovation the building's joints were insulated, and new insulation replaced the old one. Since some of the wooden studs in the walls still were in good condition, they were kept in the façade. The changes to the walls have been adapted to the walls of the investigated building as illustrated in the drawings on the next page.

The building has a low angled pitched roof that through the years has been patched when needed. A new roof paper covering was added during the renovation and insulation added in the attics.

The building's windows were original 2-pane windows from the 70s and had issues with leakages of heat and dust particles. There were also issues with collection of rainwater. In the renovation the old windows were replaced with new three-pane windows and the glazed balcony doors were replaced as well. Due to corrosion and expansion of armament, some of the balconies were given a new layer of concrete and in some cases the armament was replaced (Hamon et al., 2016).

The renovation also included a large transformation of the outside areas with new playgrounds, paths and green areas added as illustrated in figure 34. The laundry and recycling rooms were replaced with new buildings.



Figure 32: The original facade



Figure 33: The current facade from the 90's



The facade after the renovation



Walltypes changed in the renovation

Added material
Kept material

Wall A/B 1:25

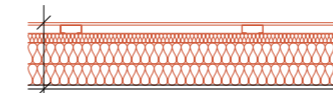

8mm cement fibreboard
27mm steel studs + air gap
30mm mineral wool insulation +
70x45mm wooden studs
2*70mm stonewool insulation +
100x45mm wooden studs
13mm gypsum board

Removed: Aluminium facade, internite panels, insulation

Wall C 1:25

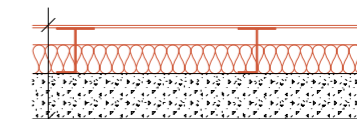

8mm cement fibreboard
55mm air gap + aluminium facade system
95mm polyurethane insulation +
aluminium facade system +
95x45mm wooden studs
150mm concrete

Removed: Wooden panel, insulation, internite panels

Wall E 1:25

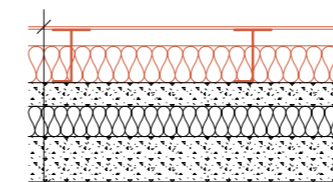

8mm cement fibreboard
55mm air gap + aluminium facade system
120mm stonewool insulation +
aluminium facade system
80mm concrete
100mm mineral wool
150mm concrete

Removed: PCB removed from joists

Added by mosaic: 2 layers of plaster, reinforcement, glass mosaic, joists

Wall D 1:25

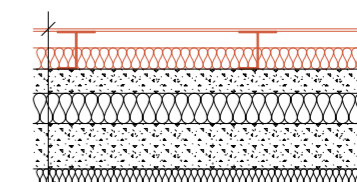

8mm cement fibreboard
55mm air gap + aluminium facade system
70mm stonewool insulation +
aluminium facade system
80mm concrete
100mm mineral wool
150mm concrete
50mm mineral wool

Removed: PCB removed from joists

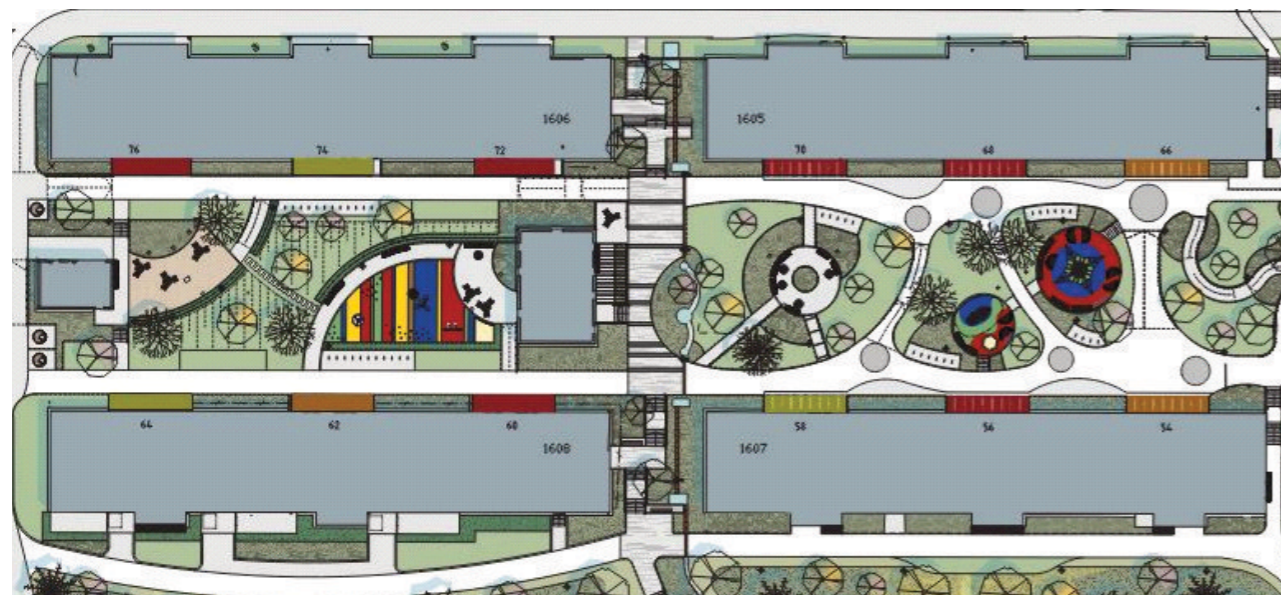

Figure 34: Site drawing over the renovated yards

*Note that there are more wall types in the building, these are the most frequent.

INTERNAL RENOVATION MEASURES

During the external renovation, moisture and fouling was discovered in the bathroom walls towards the climate shell. For health and safety reasons this caused a demand for an internal renovation. Since the bathrooms would need a change of surface materials and sealing layers it was decided to perform a pipe exchange renovation at the same time since it would be needed in a future renovation anyways. A test made on the bathroom walls without connection to the climate shell showed that no fouling occurred. There are on the other hand a lack of sealing layers in all the bathrooms and a renovation would be needed in these bathrooms as well.

To lower the extension of the renovation, bathrooms with pipe shafts facing the hallway can be left without a pipe exchange since those would be easier to access at a later time. The bathrooms without walls facing the climate shell as well as an accessible pipe shaft can therefore be left as apartments renovated without any standard increase. With similar reasoning apartment 2A of the investigated building could potentially be left without any standard increase. Since there are only 12 bathrooms in total with walls facing the climate shell, the impact from moisture and fouling is also likely not to the same extent as for the previously renovated buildings.

Since the investigated building has not yet had the external renovation performed, the interior could be renovated at the same time for increased efficiency. Due to the extent of this renovation, it is likely that the apartments will be evacuated.

RENOVATION OF THE GARAGE

The inner yards by the buildings in the upper area in Gårdsås are located on top of an underground garage. Due to leakages through the joists towards the yard, an evaluation of the garage was made, and a lacking capacity of the load bearing structure was discovered. Both concrete and armament in the load bearing pillars and joists were revealed to have extensive degradation.

A discussion is currently ongoing on whether the garage should be renovated or demolished. With the renovation option it is assumed that large measurements are needed to mend the spalling of the pillars. It is also considered likely for further damage to occur in the future (Söderman, 2018). This discussion will be brought up later in the investigative part of this report.

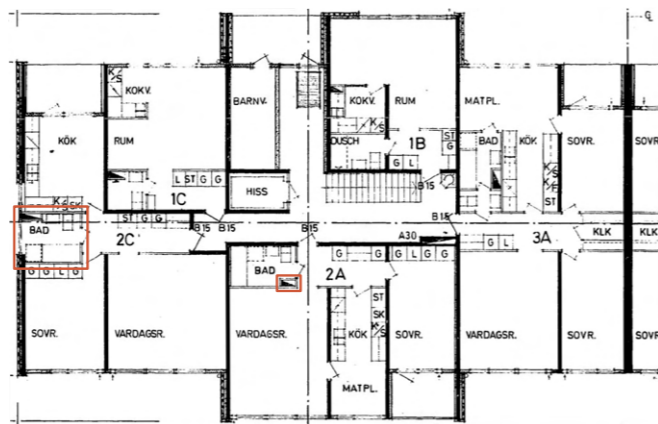

Investigated building with bathroom in apartment 2C and pishaft in apartment 2A marked

From a test done by Familjebostäder the cost for evacuating apartments turned out to be almost the same as for having the tenants stay in the apartments. Since there previously have been larger tenant satisfaction with evacuation, that was the selected measure. In the apartments where no standard increase will be done the tenants are able to remain. Usually, two staircases are evacuated at a time and the empty apartments rented on short-term contracts before the renovation starts (Familjebostäder, 2021).

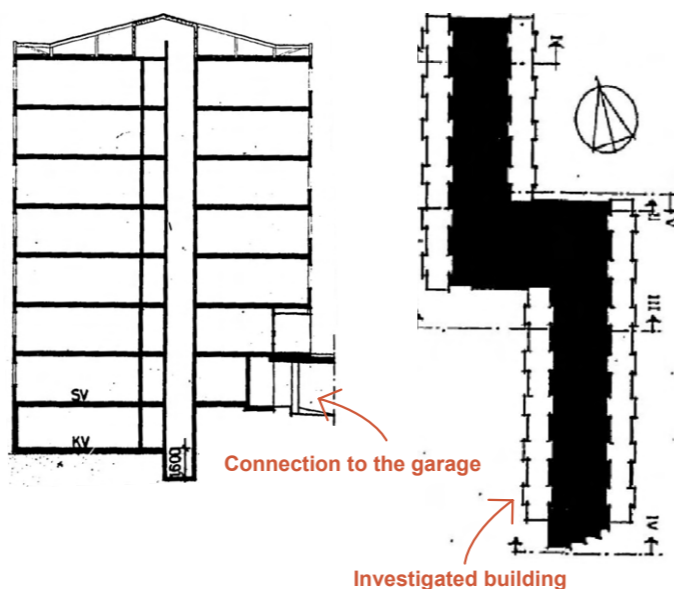

Section of the investigated building and siteplan the yard with the garage marked in black

PLANNED HOUSING

Alongside the renovations of the current buildings at Siriusgatan there is a new detail plan suggestion in development. The suggested plan creates new possibilities for housing and aims to increase the building variety in the area together with accessibility and safety. The suggestion enables in total the construction of 100 new residences, both terraced housing and apartment buildings with some of them in the vicinity of the case building in this project. The housing is planned to be condominiums and housing with ownership rights. The owners of the land are Familjebostäder and the plan has been developed by them together with the public housing company Egnahemsbolaget who are also a part of the Framtiden Group. At the time of this thesis the suggestion has been appealed and is still in negotiation.

The suggested detail plan allows for extensions by the existing housing, enabling roof terraces and expansions on the roof to create space for alternative ventilation. The plan also enables construction of new buildings on the yards without restricted heights. In the plan description buildings for common activities, laundry, bicycle parking and recycling are suggested. As part of the future development in the area the detail plan also includes potential to add one floor high extensions on the ground level for some of the existing housing. The extensions are placed along the buildings furthest east and west in the area and are meant to increase the safety along the current walking paths.

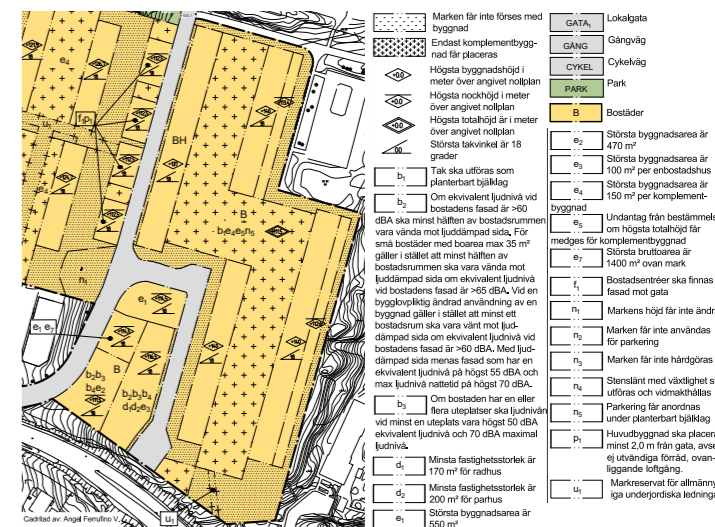

Figure 35: Suggested detail plan in the eastern area, including the case building

In the pre-study of the detail plan a description of the future traffic situation was mentioned. The expectations are that the car traffic will decrease from 39% to 22% by 2035 while the pedestrian and bicycle traffic will increase from 24% to 30%. It was also stated that the area has large heights differences which can cause issues with accessibility for people with limited mobility (Stadsbyggnadskontoret, 2022).

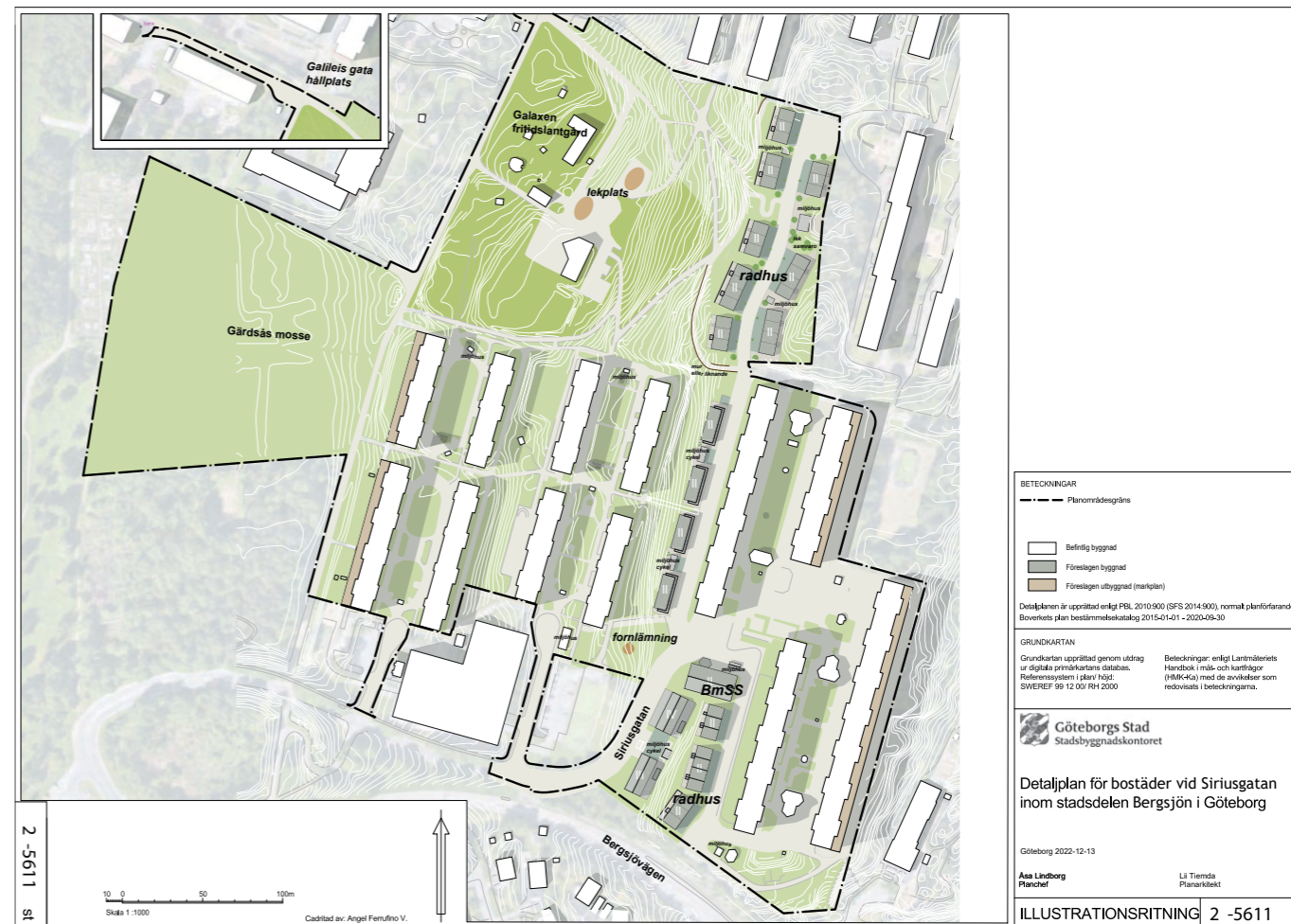
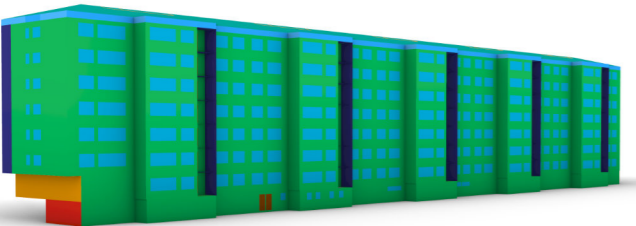
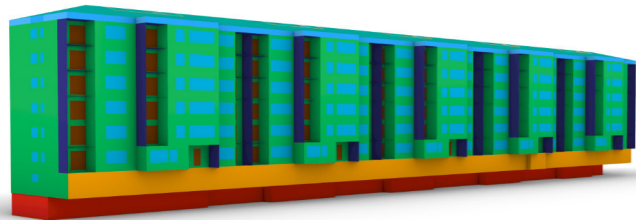

Figure 36: Full illustration drawing of the suggested detail plan

CAALA MODEL SETTINGS

To run simulations in CAALA there are several input adjustments made to accurately match the calculation to the investigated case. The first test using CAALA is a comparison between the existing building as it is now without any renovation measurements made to it, and the building with the original renovation measurements as performed at the previous buildings. The settings for the renovated model have then been kept for the later investigations. Following are the settings shared between the two versions, the settings for the existing building with the old construction and finally the settings used for the renovated model.



CAALA model used in the simulations

Shared input data

Project type: Apartment building - Retrofit analysis

Climate: Region 10 - Hof (German climate similar to the climate in Gothenburg)

Database: Oekobaudat version 2020

By limiting the scope to residential housing, the possibility to calculate the building's primary energy demand is enabled. The calculation is based on the German standard DIN V 18599 and in this investigation the primary energy factors for heat and electricity have been adjusted using the weighting factors for calculation of energy performance in Sweden. The investigation is also limited to fit the local climate. As previously mentioned, the climate impact data is taken from the Oekobaudat database but have been compared to the climate impact from the material's EPD or the Boverket database.

Average floor height: 2.72 m

Number of floors: 8

Volume: 35526 m³

Energy reference area: 11640 m²

The geometry data is automatically estimated based on the geometry of the Sketchup model used in the calculation. The average floor height and number of levels have been adjusted manually to increase the accuracy and the energy reference area has been set after the reference area used in the building's energy declaration.

Assessed lifecycle modules: A1-A3, B4, B6, C3, C4

The chosen lifecycle modules ensure results from both the construction and usage phase. The phases D1 and D2 are excluded from the calculation.

Ventilation: Mechanical with no heat recovery

Warm water usage: 19.38 kWh/(m²*year)

Since the building has exhaust air ventilation the calculation is including mechanical ventilation with no heat recovery as according to the energy declaration. From the energy declaration the warm water usage was taken as well and divided over the energy reference area.

Heat generation equipment: District heating (CHP)

Primary energy factor heat: 0.7

Primary energy factor electricity: 1.8

The building is connected to the Swedish district heating network and the primary energy factors for heat and electricity have been adjusted using the weighting factors for calculation of energy performance in Sweden. The factors are used to represent the environmental impact of the energy source to promote the use of fossil free energy. Here the values are set as according to Boverket's regulations and general advice as updated 2020 to be able to compare to the current regulation. In the information from Göteborg Energi alternative primary energy factors were given, 0.2 for heating and 1.3 for electricity. These values were calculated according to the method of VMK (Värmemarknadskommittén) which is a group with representatives from the building industry that aims to provide more in-depth climate information about the district heating used in Sweden from an accounting point of view. Since Göteborg Energi largely produces energy from recycled and renewable sources, the values end up lower compared to the values from Boverket.

CO2-Intensity heating: 0.03 kg CO₂-eq/kWh

CO2-Intensity electricity: 0.08 kg CO₂-eq/kWh

Compared to other countries large parts of both the district heating as well as the electricity in Sweden comes from fossil free sources and have low global warming potential. To adjust the environmental impact from the energy sources the carbon dioxide intensity has been changed according to values from Göteborg Energi for district heating and Vattenfall for electricity.

Specific data - Existing building

Thermal bridge surcharge: 0.10 W/m²K (general)

Air tightness: n₅₀ = 6 h⁻¹ (old construction)

NFA: 10092 m²

GFA: 12615 m²

For the technical input boundaries of the unrenovated building the "worst" settings have been applied with the highest thermal bridge surcharge and air tightness. Since the building has exhaust air ventilation the air tightness could potentially be set to a lower value, however as the technical reports done for the previous renovations showed large leakages in the construction the high values have been kept.

Specific data - Original renovation

Thermal bridge surcharge: 0.05 W/m²K (enhanced)

Air tightness: n₅₀ = 4 h⁻¹ (new construction)

NFA: 10449 m²

GFA: 13061 m²

The technical data of the renovated building are set to lower values than the unrenovated building, assuming that thermal bridges and air tightness have been improved. These values could be lowered further, the thermal bridge surcharge down to 0.02 W/m²K and the air tightness down to 1 h⁻¹ with mechanical air ventilation. Since the values selected led to a similar reduction of energy as measured from the previous renovations they have been kept at the relatively conservative reduction.

Material lifetimes of building parts

Facade: 50 years

Balconies: 50 years

Roof: 30 years

Windows: 50 years

For the adjusted materials in the renovated building the lifetimes have been adjusted for each of the materials. Above are the average lifetimes set to the added materials for each building part.

RESULTS BEFORE AND AFTER RENOVATION

LCA - Global warming potential

All the following simulations have been performed over 50 years and the net floor area used for the calculation of global warming potential of the unrenovated building is ca 10 100 m² and for the renovated building ca 10 400 m².

When lifecycle assessments are made for renovation projects, the material of the old construction is excluded and the added materials are considered the start of a new life cycle. This is also the case in CAALA. After the materials have been added in CAALA the old building parts and materials are marked as existing and are excluded from any embodied impact. The materials are however still present in the model and will impact the physics of the model during the calculations. In the LCA for the unrenovated building there are therefore no embodied impact from the materials. In reality there would also be impact from repair, maintenance and replacements.

In CAALA the material doesn't lose any of its properties over time, meaning that for example the insulation has the same insulating effects after 50 years as it does at the start of its lifetime. To compensate for this in the LCA of the old building the U-values of the walls have been adjusted to create an increased heat loss. In the report made by Familjebostäder in preparation of the previous renovations, the U-value for the walls was estimated to be 0.45 W/m²K (Hamon et al., 2016).

In the LCA of the renovated building the GWP of the added material is included. The largest part of the impact comes from the exchange of windows and balcony doors (0.45 kg CO₂-eq/m²,year). Next in impact amount is wall A/B since it both has the largest wall surface and the largest amount of added material (0.18 kg CO₂-eq/m²,year). Together the walls stand for almost 27% of the total impact. Materials like wood are assumed to have a negative impact when produced and the impact is instead added at the end of its lifetime in the stages C4 and C3.

From the result of the LCA the building renovation would save ca 292 ton CO₂ over 50 years. That is around the same amount of CO₂ as flying back and forth between Gothenburg and Stockholm 1390 times (Kortspelet Klimatkoll). Excluding the impact from the used material, the GWP reduction is instead ca 720 ton, or 3430 airplane journeys.

LCC

The lifecycle cost is unlike the global warming potential already summarized over the 50 years of the investigation. In this case the gross floor area is ca 12 600 m² for the unrenovated building and ca 13 000 m² for the renovated building. The currency is in euro and one SEK is assumed to be 0.089 euro. Just as in the LCA any costs for the existing material have been excluded. In reality there would also be high costs from repair, maintenance and replacements in the

Global warming potential - Before renovation

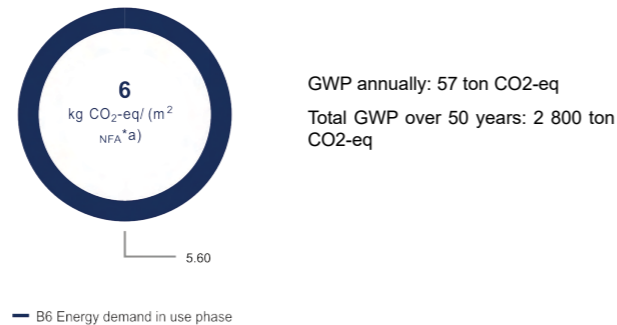

Global warming potential - After renovation

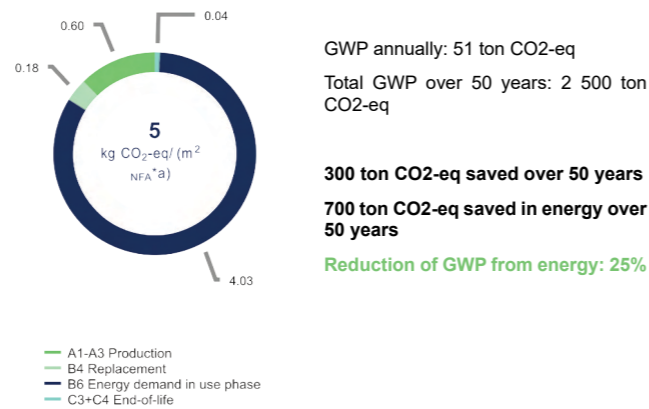

Lifecycle costs - Before renovation



Lifecycle costs - After renovation

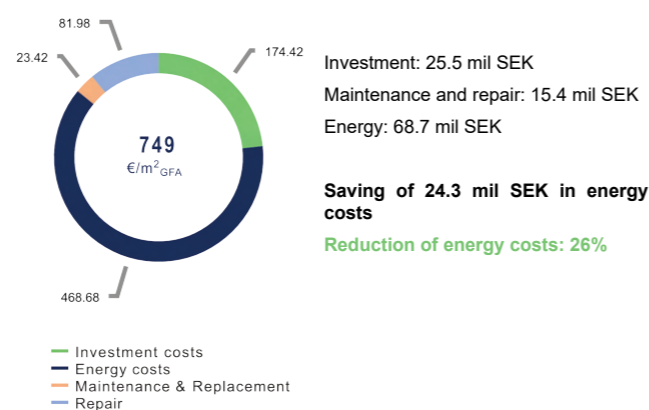

unrenovated building, especially since many of the building parts are nearing the end of their lifetime. The total investment cost is ca 25.5 mil SEK and has been manually added as investment costs/m² material area for each building part. The cost for work is included and VAT excluded. The cost for materials has been gathered from one of the already renovated buildings as a total cost and has then been applied to the original renovated building to get the material cost per m². Those costs per m² were then applied to the investigated building assuming similar measures will be performed. Since the buildings aren't identical there is a risk of error to this value.

The investment cost is ca 23% of the total cost during the 50 years while the cost for energy usage is ca 61% which makes sense since costs for building parts like the foundation and loadbearing structure could be excluded in the renovation. The reduction of total energy costs from 93.0 mil SEK to 68.7 mil SEK, a reduction of almost third, indicates that there should be good potential for the renovation to lower the long-term costs.

CAALA calculates the lifecycle costs for residences using the DGNB system. For maintenance and repair that means that the cost is a percentage of the investment cost that exponentially increases every year. This can in some cases be contradictable since a high investment cost can lead to lower costs for maintenance.

Primary energy demand

The primary energy demand is divided by the energy reference area which is set to 11 640 m² as stated in the building's energy declaration. It is calculated based on the operational energy divided as shown in the tables below. The hot water demand of 19 kWh/m² has been set manually to match the value in the energy declaration.

As previously mentioned, the primary energy demand is calculated using factors for different energy sources, in this case electricity and district heating. These values make a large difference in the result where the primary energy demand calculated using the values from Göteborg Energi becomes almost a third of the value calculated with the values from Boverket.

With Boverket's values the primary energy demand for the renovated building is above the reference value of 75 kWh/m²,year for residential buildings as stated in Boverket's regulations. However, since the old building's primary energy demand also is higher than that stated in the energy declaration this could be a fault of the model, and potentially the overall air tightness and thermal bridges should be improved for both the calculations. After the renovation the building's energy usage is lowered by ca 25% which matches the energy reduction of 20% from the previous renovations, indicating that the overall reduction of GWP and cost from energy usage in the calculations should be close to realistic values.

Primary energy demand - Before renovation



Primary energy demand	110 kWh/(m ² AN*a)
District heating CHP	127 kWh/(m ² AN*a)
Hot water	19 kWh/(m ² AN*a)
Auxiliary electricity	6 kWh/(m ² AN*a)
User Electricity	0 kWh/(m ² NFA*a)

Primary energy demand - After renovation



Primary energy demand	82 kWh/(m ² AN*a)
District heating CHP	87 kWh/(m ² AN*a)
Hot water	19 kWh/(m ² AN*a)
Auxiliary electricity	5 kWh/(m ² AN*a)
User Electricity	0 kWh/(m ² NFA*a)

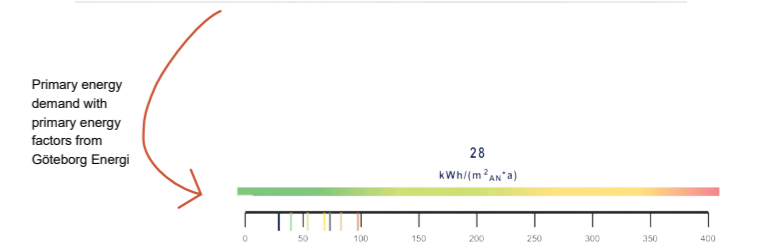

INVESTIGATION

RENOVATION OR DEMOLITION

When a large part of a building is replaced during a renovation it can be questioned whether it would be more profitable to demolish the entire construction and rebuild. However, a large part of the building's embodied carbon is within its load bearing structure and foundation and maintaining these building parts have positive environmental effects. To investigate whether a renovation also can be motivated economically, the following test compares the costs from renovating the building with the costs from demolishing and rebuilding it.

To increase the potential income from the renovation project, the calculation is including the additional income from an extension of the original building. For this test a floor with apartments has been added on top of the existing structure. While the current detail plan doesn't allow for a full floor addition to the building, the suggested detail plan adds 3 meters allowed building height, making an addition potentially possible.

To test the income potential from a fully exploited area, the calculation also includes the additional income from the planned apartments and terraced housing in the vicinity of the case building. In reality these buildings are developed by another housing company and won't directly impact the profitability for Familjebostäder. There is also more planned new construction in the area as well as more buildings in need of renovation that should be included for a full realistic calculation.

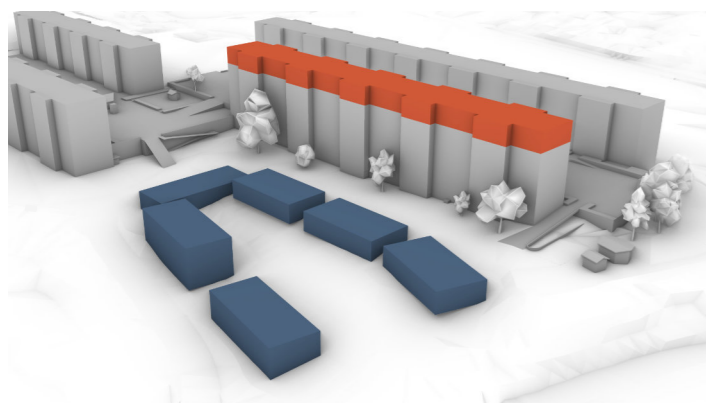

Volumes representing the rooftop extension in red and the planned housing in blue

Demolition and building new

The costs for demolition have been calculated with the help of the construction company Rival Bygg Rivning Demontering AB. Since there is a high risk of asbestos occurring in some of the façade panels as well as in parts of the internal structure there is also a cost for decontamination.

Cost for demolition: 21 mil SEK

Cost for decontamination: 2 mil SEK

To calculate the cost for construction, average values have been used from Statistics Sweden's database. In 2017 the average building cost per square meter apartment area for new production was 31 382 SEK/m² (SCB, 2018). The value is derived from costs in the larger city areas in Sweden (such as Gothenburg) and has not been adjusted with any subventions. Since there have been large changes in construction costs in Sweden since 2017 the cost has been recalculated to a representative value of today utilising the Swedish construction cost index CCI. The CCI for 2022 is 2116 and in 2017 it was 1658.3 (SCB, 2023). By dividing 2116 with 1658.3 an average increase of ca 28% is retrieved which means that the building cost today should be around 40 000 SEK/m². Assuming the same apartment area of 9067 m² is built with the new construction, the total cost for the rebuild becomes ca 363 mil SEK.

Cost for new production: 363 mil SEK

In reality the new apartments would likely have higher rents compared to the older renovated apartments which would lead to higher profitability, for simplification that additional income is excluded here.

Total demolition and rebuilding costs: 386 mil SEK

Renovation

The costs for the renovation are the same as presented in the case study. The climate shell renovation is using the material and work hour costs from the material bill adjusted to the scale of the investigated building and the internal and yard renovation costs have been estimated from previous costs using the building gross floor area.

Project cost climate shell renovation: 26 mil SEK

Project cost yard renovation: 31 mil SEK

Project cost internal renovation: 74 mil SEK

Total cost for renovation: 131 mil SEK

New extensions

The cost for the construction of the rooftop extension is calculated using the same values as for the demolition (40 000 SEK/m²). The new rentable area created is estimated to be around 1500 m². No consideration is done to the loadbearing structure which could need reinforcements leading to additional costs.

Cost for construction of rooftop extension: 60 mil SEK

The net income from the new housing is calculated using SCB's values for average income and operational costs for rental apartments. The incomes and costs are also limited to publicly owned housing in larger cities in Sweden. The used value for income is 1170 SEK/m² (SCB, 2017) and the value for operational costs 398 SEK/m² (SCB, 2017). The difference between these two values then becomes 772 SEK/m². Since the available costs were collected in 2015 the value has been adjusted to today's inflation rate using the consumer price index, CPI, which in 2015 was 313.35 and in 2022 was 371.91 leading to an increase of ca 19% (SCB, 2023). The value has been multiplied over 50 years to consider the income throughout the building's lifetime. The income will very likely change over time and this final income should be considered a rough estimation.

Income from extension over a 50-year period: 69 mil SEK

No design decisions are made in this thesis regarding the nearby planned housing and for the income calculation the design presented in the illustration plan connected to the proposed detail plan has been used. The total created floor area is roughly estimated to be 3800 m². For simplification all the buildings are assumed to be apartment buildings and will use the same values as for the roof extension. The land is assumed to be already owned by the company.

Cost for construction of nearby buildings: 152 mil SEK

Income from new housing over a 50-year period: 174 mil SEK

Total profit from extensions: 31 mil SEK

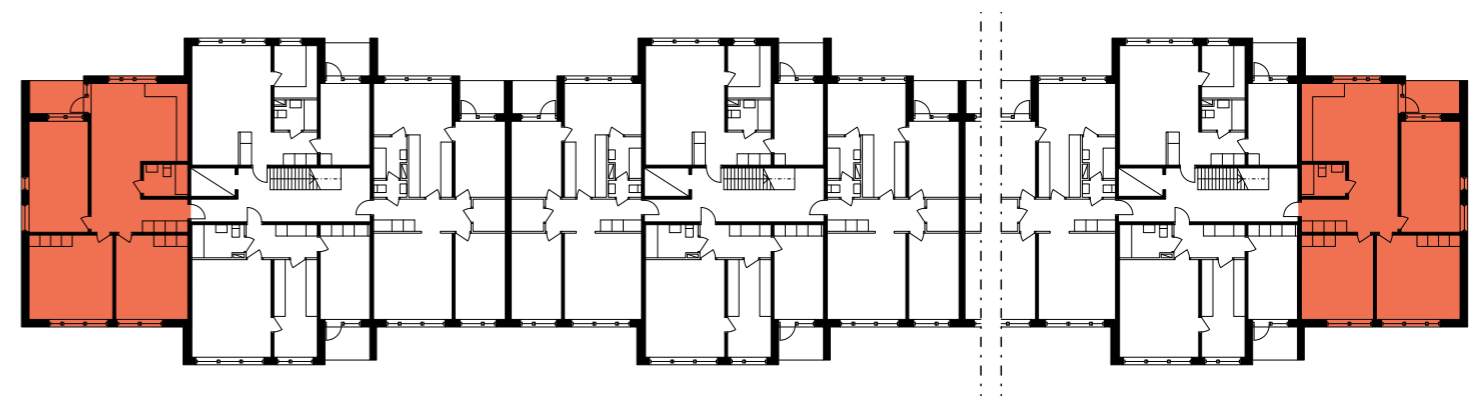

Floorplan of the extension 1:400, most of the apartments are kept as on the lower floors, and the corner apartments are merged to create a larger apartment marked in red above

Result

When demolishing today there is a focus on reuse, and it has been decided by EU that in 2030 70% of all demolished material should be reused (Rival, n.d.). If the current technique allows it and larger parts of the load bearing structure needs to be replaced, a demolition might then be more profitable both environmentally and economically. In this building however the load bearing structure could be maintained.

While the extension in this investigation increases the profitability of the project it is not included in the following lifecycle assessments. The extension wouldn't need to repeat the construction of the existing building and would realistically have its own bill of material. By excluding it, the lifecycle assessments will instead focus on the changes to the existing building construction. With the extension added, the existing building would likely lower its energy usage since the top floor would be protected from the outdoor climate. This would also lead to lower costs over time for heating of the current apartments.

Total demolition and rebuilding costs: 386 mil SEK
Total cost for renovation & extensions: 100 mil SEK
Renovation & extensions cheaper by 286 mil SEK

REMOVING THE GARAGE

Due to corrosion and leakages the garage structure underneath the inner yards of the building needs to be renovated. Familjebostäder is currently in discussion of which measure should be taken. The two options from the technical investigation of the garage are either to demolish and rebuild it as it is now or to renovate it. An alternative to this could be to remove the garage from the inner yards entirely. By doing so space would be created for apartments on the souterrain levels currently facing the garage. To resolve the conflict with resident's wishes for parking space, the garage could be moved to another location in the area. Following is an investigation of costs from the three alternatives, renovating the existing garage, demolishing the garage and rebuilding it in the same place and finally demolishing the garage and rebuilding it to a smaller extent in another area. Income from parking spaces is excluded from the calculation.

Renovation

In a pre-study of the potential garage measures, the full cost for renovation was estimated to be 220 million SEK. This value was given as a very rough estimation as it is considered likely that further issues will be encountered in the renovation process and increase the cost. With this measure there is also a large risk of parking lots being removed since the load bearing pillars needs to be strengthened and will take up larger space.

Cost for renovation: 220 mil SEK

Demolition and rebuilding

In the same pre-study, an estimation of the cost for demolition and full rebuild was made. This solution was recommended as the safer option in the study but should also be considered as a rough estimation.

Cost for demolition & rebuild: 375 mil SEK

Demolition and building new

The cost for demolition of the garage without any further action was provided in the case study as well. Removing the demolition cost from the cost for demolition and rebuilding also gives the cost for the garage construction.

Cost for demolition: 11 mil SEK

Cost for construction: 364 mil SEK

In this calculation the garage space in the original site drawing from 1970 has been suggested as a new space for the garage. One of the garage buildings has already been

made and is here given an additional level. Since parking building three is located on a hill, it is assumed that it can be made with three levels in a similar manner to the existing parking building. The football court has been maintained as it is described in tenant interviews as a very popular area. These changes would demand adjustments of the detail plan. In total the new parking space area created is 9700 m², which is ca 80% of the original garage. A new construction cost was calculated using the new area and the same construction cost as for the original garage.

Cost for construction of the new garage: 281 mil SEK

New income has been calculated for the space created on the souterrain floor using the same data from the calculation of income from the extensions in the previous test. The average income and operational costs were taken from the database of Statistics Sweden (SCB, 2017) and the net income was then recalculated to today's value using the CPI. The final income adjusted for inflation in 2022 becomes 916 SEK/m². The new floor area created for apartments on the souterrain floor is ca 381 m². Assuming the same percentage of floor area can be renovated for the other buildings connected to the garage, the total new apartment area becomes 1673 m². With these values the additional income from the apartments could be calculated.

Total income from new apartments over a 50-year period: 76.62 mil SEK

As previously mentioned it is very likely that the rent will change over the 50-year period, but this value will be used as an estimation.

The cost for the renovation of the climate shell and internal walls of the investigated building has been calculated using Wikells Sektionsfakta and is estimated to be ca 3 mil SEK. The same level of measures is assumed to be performed for the rest of the buildings connected to the garage.

Cost for renovation of apartments: 13 mil SEK

Cost for demolition & building new: 215 mil SEK

Result

It can be concluded from this test that the cost for building the new garage is slightly cheaper than the renovation and since it is also more interesting from an architectural perspective to investigate, that's the option which was chosen. Since these calculations all are based on estimated values and there is no developed plan for the new garage there could be other results from a more in-depth investigation.

The new site plan is based on the original renovation but also has added buildings for bicycle storage assuming that the area will follow the trend of decreased vehicle traffic and

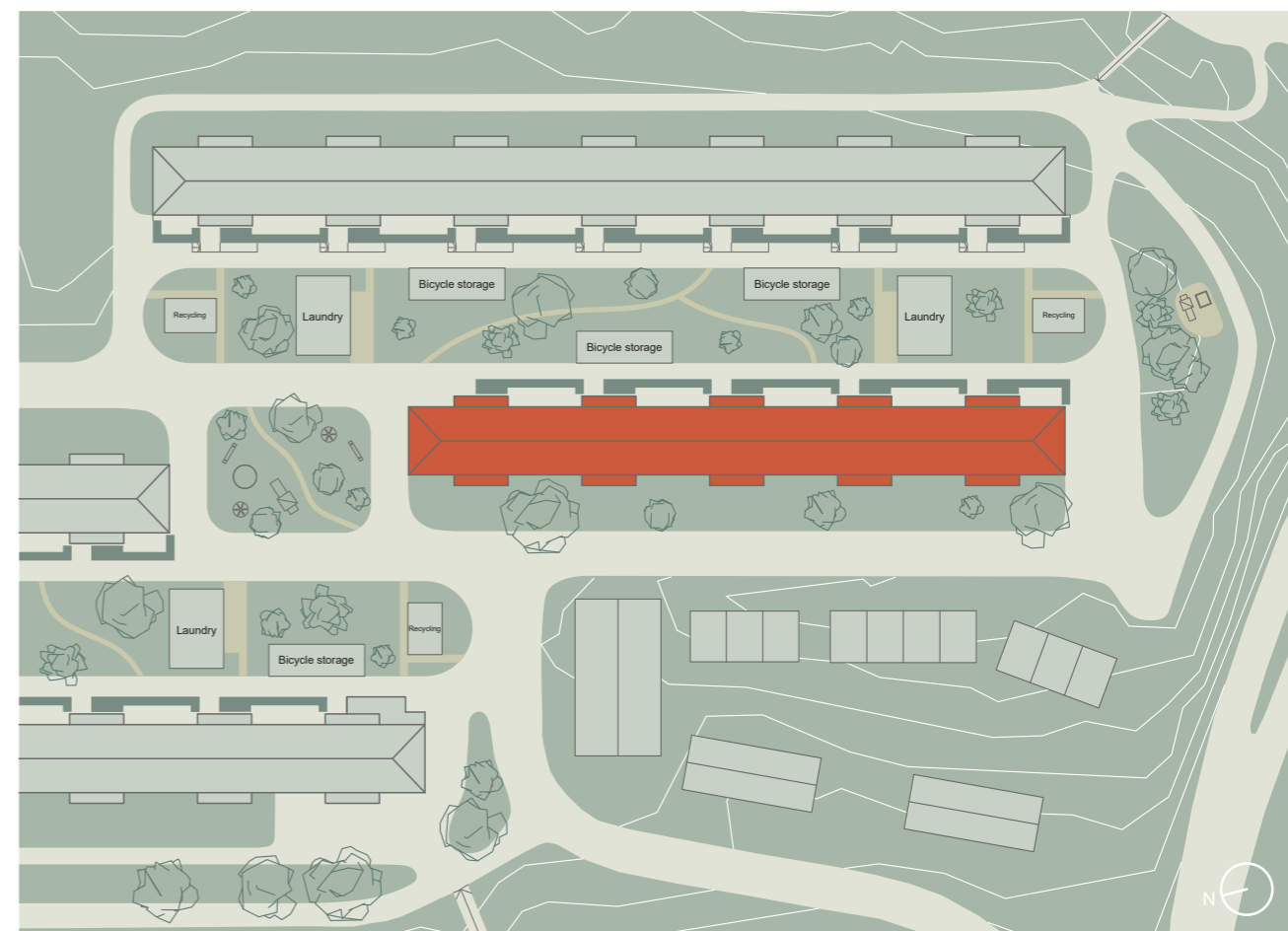

New yard area after removal of the garage, 1:1400

increased bicycle traffic. The new yard areas would also have improved accessibility due to the removed height difference caused by the garage.

- • • • •
- **Cost for renovation: 220 mil SEK**
- **Cost for demolition & rebuild: 375 mil SEK**
- **Cost for demolition & building new: 215 mil SEK**
- _____
- **Demolition and building new cheaper by 5 mil SEK compared to renovation**
- **Demolition and building new cheaper by 160 mil SEK compared to demolition and rebuilding**
- • • • •

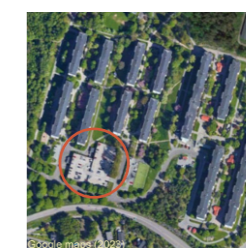

Location of current garage

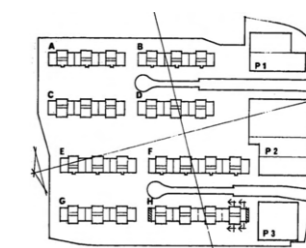

Garage placement in original drawings



Potential placement of the new garage

GLAZING OF BALCONIES

Both block G, H, I and the project in Gårdsten used glazed balconies as a method for lowering their building's energy usage. In Gårdsten, where the climate is the same as for the case building, the glazed balconies both preheated the ventilation air and lowered the transmittance heat loss through the climate shell.

In CAALA the glazing of the balconies has been modelled by changing the balconies into unheated spaces. The walls connected to the balconies are then automatically given lower U-values to lower the transmittance heat loss. In reality there would also be impact from heat gain of the sun and dependence on the U-values from the glazing. Hence, for a realistic result there needs to be a more dynamic investigation of heat flows than what is possible to do in CAALA.

Below are the results from the balcony glazing test which shows the reduction of energy usage as possible to set in CAALA. Since the net floor area and gross floor area changed between the models used for this calculation the values have been multiplied with the area for comparison. While it at first appears as if the cost and environmental impact from energy usage has increased, this is not the case. Due to the insecurity of the calculation results, it is assumed in the following tests that the balconies are unglazed.

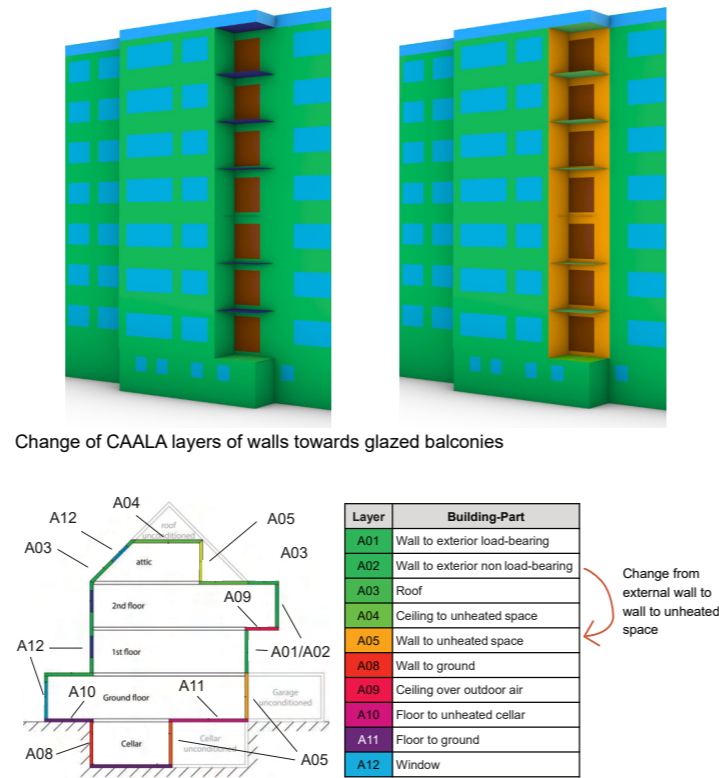
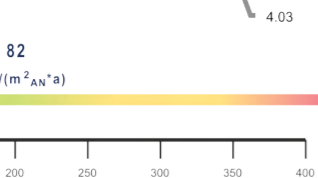
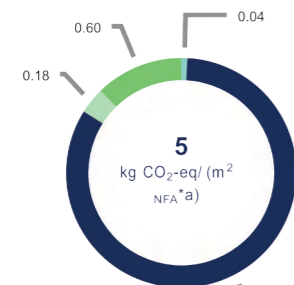
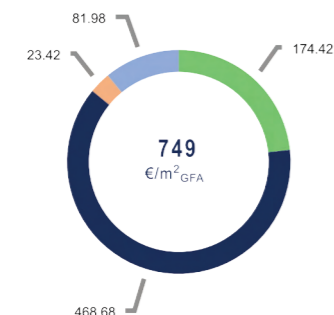

Figure 11: CAALA layers for the preliminary planning phase

Without balconies

GFA: 13061 m²
NFA: 10449 m²
Energy reference area: 11640 m²



With balconies

GFA: 12615 m²
NFA: 10092 m²
Energy reference area: 11640 m²
Investment cost: 4126 SEK/m²

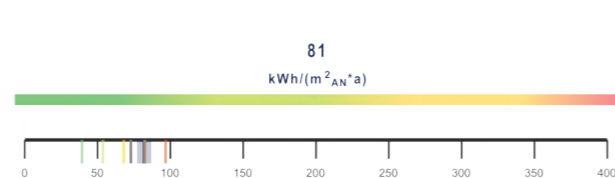
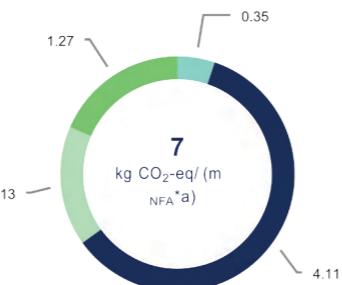
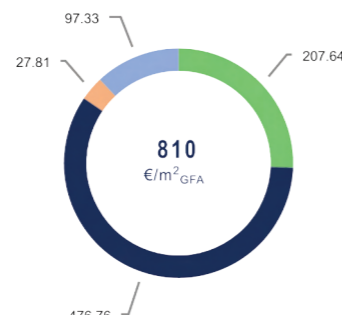

Reduction of 1.2 mil SEK over 50 years in energy costs.
Increase of total costs with 2 mil SEK over 50 years

GWP from energy usage: 2073 ton CO₂-eq over 50 years
Total reduction of 31.6 ton CO₂-eq (1.5%) from energy
Total increase of GWP with 17%

FTX SYSTEM

The possibility to install an FTX system has previously been investigated by Familjebostäder and it was planned for an extension to be built on the roof to fit the equipment. Since the extension didn't comply with the detail plan the investment was decided against. The proposed adjustments in the detail plan would make the extension possible and the installation of FTX would be feasible. In the following test the impact from the FTX system on the cost and energy usage is explored.

An FTX system uses an aggregate to preheat the supply air before it is used to ventilate the apartments. The system also has mechanical fans controlling both the supply and exhaust air. In the aggregate the exhaust air is used to preheat the supply air which leads to less energy needed to heat the ventilation air. The FTX system can recycle up to 80% of the air, which is the value that has been used in the calculation (Svensk Ventilation, n.d.).

With the FTX system both the energy cost and global warming potential for energy got reduced with almost 30%. This makes the FTX system the most effective energy reducing measure out of all the tests made. Since the cost for investment, maintenance and repair outweighs the costs saved from energy this is still not enough to be profitable during a 50-year period.

As previously mentioned, the maintenance cost in CAALA is calculated as an exponential increase from a percentage of the investment costs. Since the investments cost here is including the cost for the construction of the extension it could be that the maintenance costs for the FTX system are lower in reality. As the system showed large potential for lowering the GWP it would be interesting in future tests to do a more in-depth investigation of the FTX maintenance costs. Alternative methods for preheating ventilation air would also be an interesting aspect to investigate further.

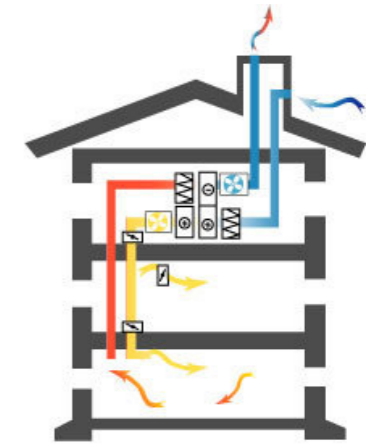

Figure 37: Principle drawing of an FTX system

COMMENT ON WINDOWS

In the original renovation the double-glazed windows from the 70s were exchanged due to issues with leakages. The replacing windows are triple glazed with a U-value varying from 0.9 to 1.2 W/m²K. In CAALA the U-value 0.9 has been used, which is one of the lowest U-values available. Using Wikells Sektionsfakta it can be assumed that the investment cost for a more energy efficient window would be ca 25% higher than the original cost, which in this case would not be profitable.

The windows have a wooden frame with an aluminium cover. While aluminium is a material with a high embodied carbon it in this case it lowers the need for maintenance of the wood since it doesn't need painting. A window with a wooden frame needs to be painted around every 10th year but has low environmental impact and a low investment cost. With a window fully in aluminium the need for maintenance is low but the embodied carbon is much higher. The aluminium covered wooden windows seem in this case to be a good compromise and the original window choice has been kept in this study.



Figure 38: Window type used in the original renovation

With FTX system

Investment cost: 8.2 mil SEK

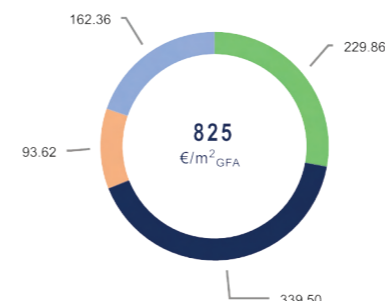

Increase of total costs with 21.97 mil SEK over 50 years, 42% of initial cost

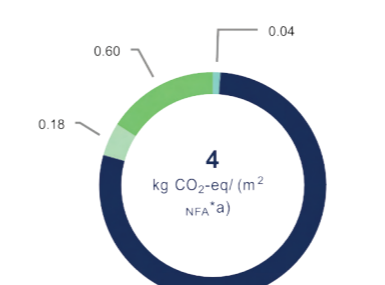

Saving of 564 ton CO₂-eq over 50 years
Total reduction of GWP with 27%

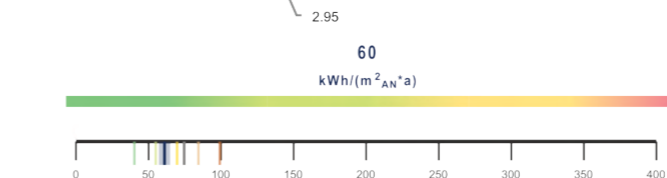

INSULATION OF THE SOUTERRAIN FLOOR

In the previous segment the removal of the underground garage was investigated. If the garage is removed this leaves the walls previously facing the garage exposed and creates potential space for new housing. To make this area liveable it needs to be insulated which will lead to reduced energy usage, but also leads to additional investment costs.

By using average costs for wall demolitions and work costs for adding windows and doors from Wikells Sektionsfakta the cost for renovating the souterrain floor is estimated to be around 3 mil SEK. The material costs per m² for windows, balcony doors and entrance doors are assumed to be the same as in the original renovation. Wikells Sektionsfakta was also used to add the costs for the floor insulation and the work costs for insulation of the walls. Otherwise, the same material costs have been used for the stone wool insulation, façade material and façade mounting system as before. The hot water usage is set to 20 kWh/m² to account for the increased water usage with the added apartments

The souterrain floor was in the previous test already part of the heated area which means that the energy reference area stays the same in the calculation with the added apartments. No test of thermal comfort has been done in this investigation which should be performed for the new apartments to ensure that the added insulation amount is sufficient.

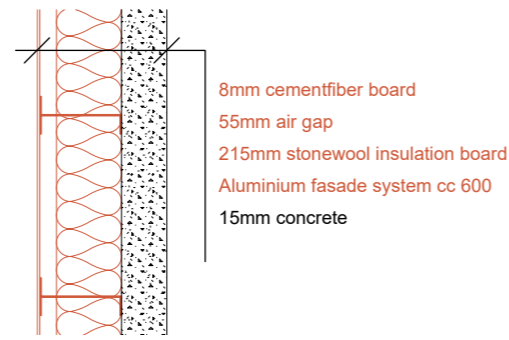

New section through the insulated souterrain wall 1:25

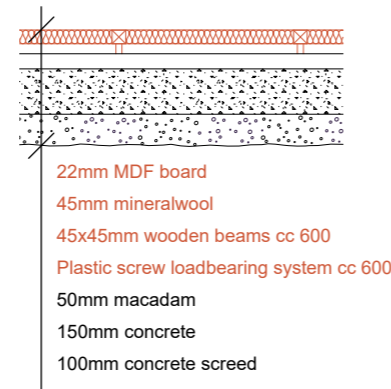

New section through the insulated souterrain floor 1:25



New section through entrances 1:200

Original renovation

GFA: 13061 m²
NFA: 10449 m²
Energy reference area: 11640 m²

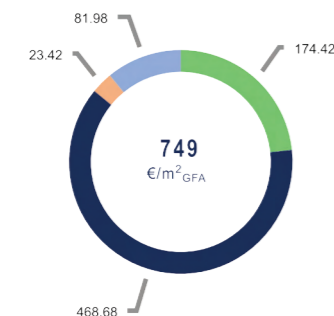

Lifecycle cost

- Investment costs
- Energy costs
- Maintenance & Replacement
- Repair

Global warming potential

- A1-A3 Production
- B4 Replacement
- B6 Energy demand in use phase
- C3+C4 End-of-life

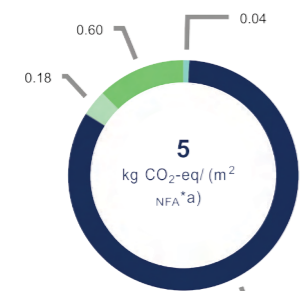

Primary energy demand

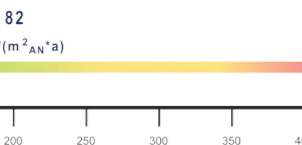

Insulated souterrain

GFA: 13040 m²
NFA: 10432 m²
Energy reference area: 11640 m²

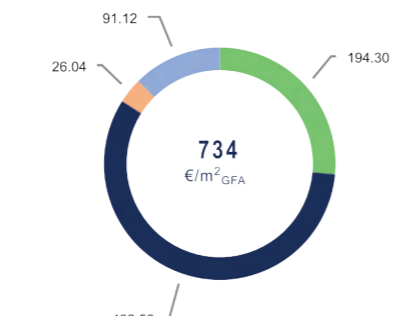

Cost for investment & repairs/maintenance: 45.8 mil SEK, increased with 4.3 mil SEK

Cost for energy: 61.9 mil SEK, reduced with 6.9 mil SEK

In total 2 mil SEK over 50 years or 2% of the costs saved

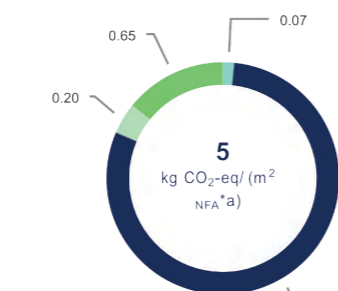

Total embodied GWP over 50 years ca 480 ton CO₂-eq, increased with 12%, 51 ton CO₂-eq released

Total GWP from energy usage over 50 years ca 1904 ton CO₂-eq, decreased with 10%, 202 ton CO₂-eq saved

In total 151 ton or 7% CO₂-eq saved

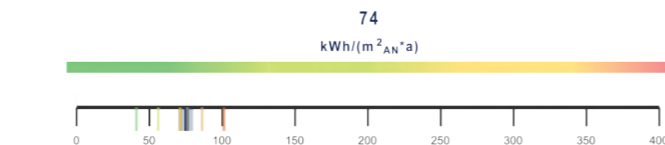

Architectural qualities

With the removal of the garage a new entrance situation is created when entering the souterrain floor from the yard. Since the layout on the souterrain floor is similar to that of the entrance floor, there is potential to open up the entrances over two floors. This would increase the brightness by the entrances and function as a more welcoming space when entering the building. The larger opening would also be an improvement of the connection to the yard by increasing the visibility from the staircases to the outdoor spaces.

The result shows that the insulation reduces the total costs with 2% over 50 years which doesn't seem like a large amount. The renovation will however pay for itself and there are further reduced costs from the energy saving. Note that the investigation is excluding the costs for appliances and internal materials as well as the additional income from rents. The energy usage on the other hand gets lowered by 7%, in the following tests it is therefor assumed that the renovation of the souterrain has already been performed.

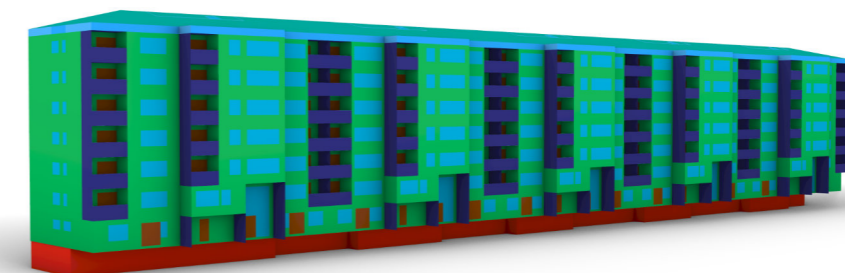

New CAALA model used in the calculation

WALL CONSTRUCTION

Walltypes changed in the renovation

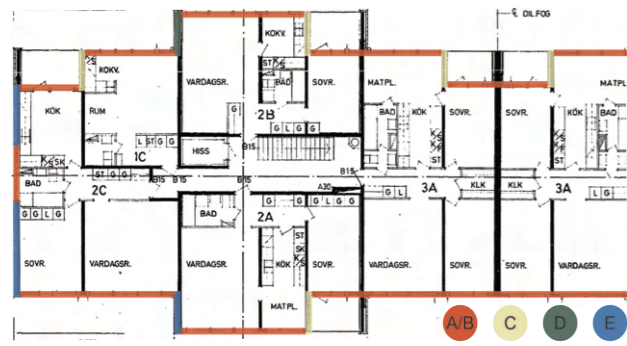

Original

Wood

<p>Wall A/B 1:25 U-value: 0.19 W/m²K Cost: 1491 SEK/m²</p> <p>8mm cement fibreboard 27mm steel studs + air gap 30mm mineral wool insulation + 70x45mm wooden studs 2*70mm stonewool insulation + 100x45mm wooden studs 13mm gypsum board</p>	<p>Wall C 1:25 U-value: 0.16 W/m²K Cost: 1258 SEK/m²</p> <p>8mm cement fibreboard 27mm wooden studs + air gap 45mm climate board (västkustskiva) + plastic mounting pipes 70mm stone wool insulation + 40x45mm wooden studs 70mm stonewool insulation + 100x45mm wooden studs 13mm gypsum board</p>
<p>Wall C 1:25 U-value: 0.43 W/m²K Cost: 1009 SEK/m²</p> <p>8mm cement fibreboard 55mm air gap + aluminium facade system 95mm polyurethane insulation + aluminium facade system + 95x45mm wooden studs 150mm concrete</p>	<p>Wall E 1:25 U-value: 0.26 W/m²K Cost: 1321 SEK/m²</p> <p>8mm cement fibreboard 55mm air gap + aluminium facade system 120mm stonewool insulation + aluminium facade system 80mm concrete 100mm mineral wool 150mm concrete</p>
<p>Wall D - similar added construction to E U-value: 0.25 W/m²K Cost: 1295 SEK/m²</p>	<p>Wall E 1:25 U-value: 0.19 W/m²K Cost: 636 SEK/m²</p> <p>8mm cement fibreboard 28x60mm wooden studs + air gap 45mm climate board (västkustskiva) + plastic mounting pipes 75mm stonewool insulation 75x45mm wooden studs 80mm concrete 100mm mineral wool 150mm concrete</p>
<p>Souterrain wall - similar added construction to E U-value: 0.34 W/m²K Cost: 1943 SEK/m² (inc.workhours)</p>	<p>Wall E 1:25 U-value: 0.20 W/m²K Cost: 1374 SEK/m² (inc.workhours)</p>

Alternative construction

Apart from the windows, the largest part of both the cost and the global warming potential comes from the external walls. As a first step in the investigation of how to improve the walls a test was done to investigate the possibility to improve the thermal properties of the climate shell. The thermal transmittance of a construction is measured with a U-value and in CAALA the U-values of the walls can be adjusted manually by changing the material's thermal conductivity (λ -value). The investment costs presented here are only including the cost for material.

The first construction method uses aluminium profiles to mount the façade boards. While this system is quick to install it has a risk of causing thermal bridges due to the uninterrupted aluminium. To counter this problem the profiles connected to the concrete has a fixed insulator towards the wall. To get a correct a U-value in CAALA the λ -values were adjusted to match the full façade system's U-value as described in the product information (ca 0.035 W/m²K through a wall with 220 mm insulation and 180 mm concrete).

The alternative construction method uses wooden studs to mount the façade boards. This alternative also has a climate board of mineral wool to break the thermal bridges. The board is mounted to the wall using plastic pipes as shown in figure 40. Unlike aluminium the wood also has a small insulating effect. In comparison, the default λ -value for aluminium in CAALA is 235 W/mK while the value for wood is 0.13 W/mK. It can be assumed that the wooden studs

have the same life length as the full wall and hence the lifetimes are kept the same for both constructions. Both constructions have the same stone wool insulation and cement fibreboards as façade materials.

The result shows that the wooden construction performs better, but the difference from the aluminium construction is not that big. Apart from saving energy, the wood construction was also cheaper to build initially. It is surprising that the embodied carbon is larger for the wooden wall. This could partly be because the glass wool used in the aluminium wall was exchanged to stone wool in the wooden construction, which had a larger environmental impact. It could also be that the amount of aluminium and steel is very low compared to the amount of wood. The amount of aluminium is set to 1% of the total wall to get the correct U-value.

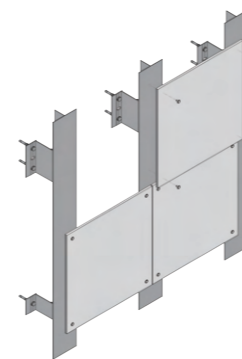

Figure 39: Aluminium profile facade system

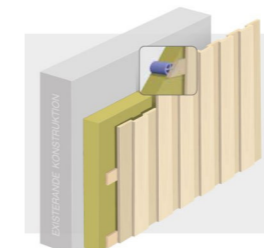

Figure 40: Mounting of facade on top of a climate board (in this project the studs are vertical)

Additional insulation

To test the impact from the insulation amount, the walls A/B and C were additionally insulated to reach a wall thickness of ca 400 mm. The increased insulation doubled the amount of reduced embodied carbon while the percentual difference in cost didn't change. To decide on the insulation amount there would need to be either a more detailed calculation or a consideration to have slightly higher investment costs to have a more certain decrease in energy costs.

Walltypes with additional insulation

<p>Wall A/B 1:25 U-value: 0.10 W/m²K Cost: 1526 SEK/m²</p> <p>8mm cement fibreboard 27mm wooden studs + air gap 45mm climate board (västkustskiva) + plastic mounting pipes 220mm stone wool insulation + 220x45mm wooden studs 100mm stonewool insulation + 100mm wooden studs 13mm gypsum board</p>	<p>Wall C 1:25 U-value: 0.15 W/m²K Cost: 607 SEK/m²</p> <p>8mm cement fibreboard 27mm wooden studs + air gap 45mm climate board (västkustskiva) + plastic mounting pipes 170mm stonewool insulation + 75x45mm wooden studs + 95x45mm wooden studs 150mm concrete</p>
----------------------------------------------------------------------------------------------------------------------------------------------------------------------------------------------------------------------------------------------------------------------------------------------------------------------------------------------------------------	---------------------------------------------------------------------------------------------------------------------------------------------------------------------------------------------------------------------------------------------------------------------------------------------------------------------------

Original construction

Lifecycle cost

- Investment costs
- Energy costs
- Maintenance & Replacement
- Repair

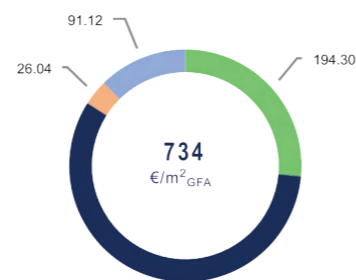

Global warming potential

- A1-A3 Production
- B4 Replacement
- B6 Energy demand in use phase
- C3+C4 End-of-life

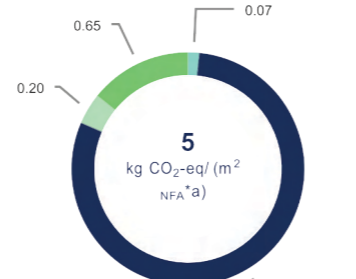

Primary energy demand

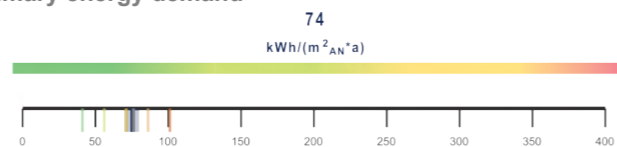

Wood construction

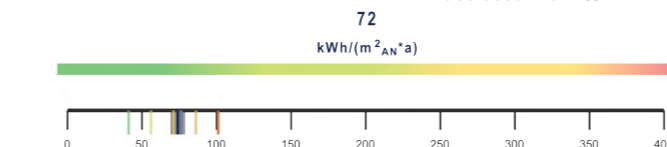
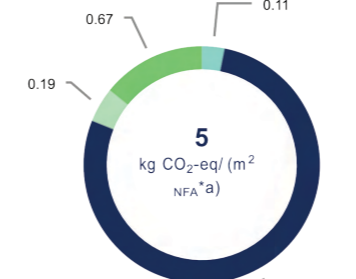
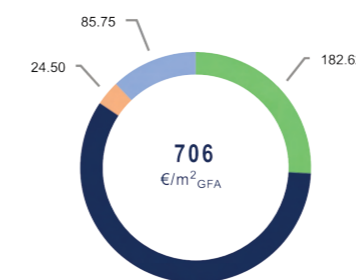

Total cost over 50 years: 103.44 mil SEK
4.1 mil SEK saved in total, 4 % of the total cost

Total cost for energy over 50 years: 60.53 mil SEK
1.38 mil SEK saved, 2% of total energy costs

Total embodied GWP over 50 years: 506 ton CO₂-eq
26 ton CO₂-eq released, increased with 5%
Total GWP for energy over 50 years: 1862 ton CO₂-eq
42 ton CO₂-eq saved, decreased with 2%

Total GWP over 50 years: 2368 ton CO₂-eq
16 ton CO₂-eq saved, decreased with 1%

Added insulation

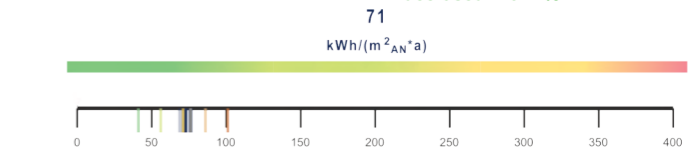
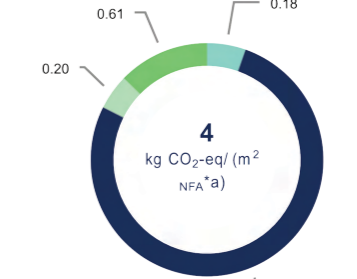
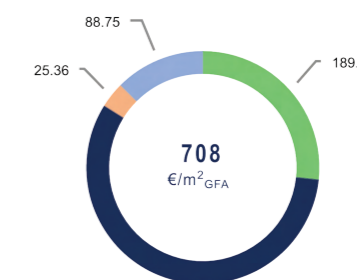

Total cost over 50 years: 103.72 mil SEK
3.8 mil SEK saved in total, 4 % of the total cost

Total cost for energy over 50 years: 59.28 mil SEK
2.5 mil SEK saved, 4% of total energy costs

Total embodied GWP over 50 years: 516 ton CO₂-eq
37 ton CO₂-eq released, increased with 8%
Total GWP for energy over 50 years: 1326 ton CO₂-eq
78 ton CO₂-eq saved, decreased with ca 4%

Total GWP over 50 years: 2342 ton CO₂-eq
42 ton CO₂-eq saved, decreased with 2%

CEMENT FIBREBOARD VS WOOD PANEL

In the following tests the wooden construction is assumed to be kept without the added insulation and only the material surface is changed.

Fibre cement is a material that contains cement, sand and cellulosic fibre. Compared to wood panels they don't need much maintenance and only needs repainting for the sake of its colour rather than functionality. While the expected lifetime for a cement fibreboard is set to 50+ years it is assumed to have the same lifetime as the construction it is part of. In the product information (not the EPD) it was also stated the life length could vary between 30-60 years.

According to Träguiden (2019), pinewood can have a lifetime of 60 years if painted. Wood types such as cedar and larch are more durable but is less common in Sweden and is therefore often imported leading to environmental impact from the transportation. A Swedish alternative is to use core wood from pine that is denser and lasts longer. To keep the price down the wooden façade panels in this test are made of common pine that has been dried and painted.

The result from the LCA shows that the total difference in global warming potential between wood and fibre cement doesn't show up at all. While the wood has lower embodied carbon in the production phase, this was made up for in the end of life and replacement phases.

Similar to the result in the construction test it could be that the larger amount of wood outweighed the amount of fibre cement.

Since CAALA considers the cost for maintenance in relation to the investment costs for a material, the cost for maintenance as shown by the diagram below might not reflect reality, as the wooden wall would need to be repainted over its lifetime. According to the guidelines provided by Träguiden, the total cost for the painting of the façade could be ca 2.3 mil SEK over 50 years meaning that the wood selection would still be cheaper (Träguiden, 2019). Since the total difference in cost isn't much and the quality of wood varies, it might be difficult in a real case to argue for the wooden façade. To follow the logics of this study the wooden façade will however still be selected for the next steps of the project.

STONE WOOL VS CELLULOSE & WOOD FIBRE

As an alternative to stone-wool, cellulose and fibrewood insulation were tested. In the tests the wooden construction and cement fibreboards were kept. There was a small adjustment made to the initial construction model in this test and the values here are not fully comparable to the LCA and LCC with the stone wool insulation (as shown with the cement fibreboards in the façade test). The following calculations have however both been made with the same construction and are comparable to each other and to the older version with the stone-wool insulation as only the insulation type was changed. All the tested insulation materials are in board-form to be able to assume that they would have the same construction method and costs.

The cellulose fibre board used in the test is made from wastepaper and is held together using bounding fibres which gives it a low embodied environmental impact. The wood fibre board is made out of wood chips that have been glued together. Since both the cellulose and wood fibre boards are made from wood materials, they both have negative environmental impact in the production phase in CAALA and then have a positive impact at the end-of-life stage.

Since the wood fibreboard had a slightly cheaper investment cost it also had a lower lifecycle cost. The wood fibreboard also had a 3 times lower environmental impact.

Compared to the wooden façade the changed insulation type was more effective in lowering the environmental impact. While it increased the costs it was at very low percentage, and it should be considered whether the increased cost could be worth the reduced global warming potential.

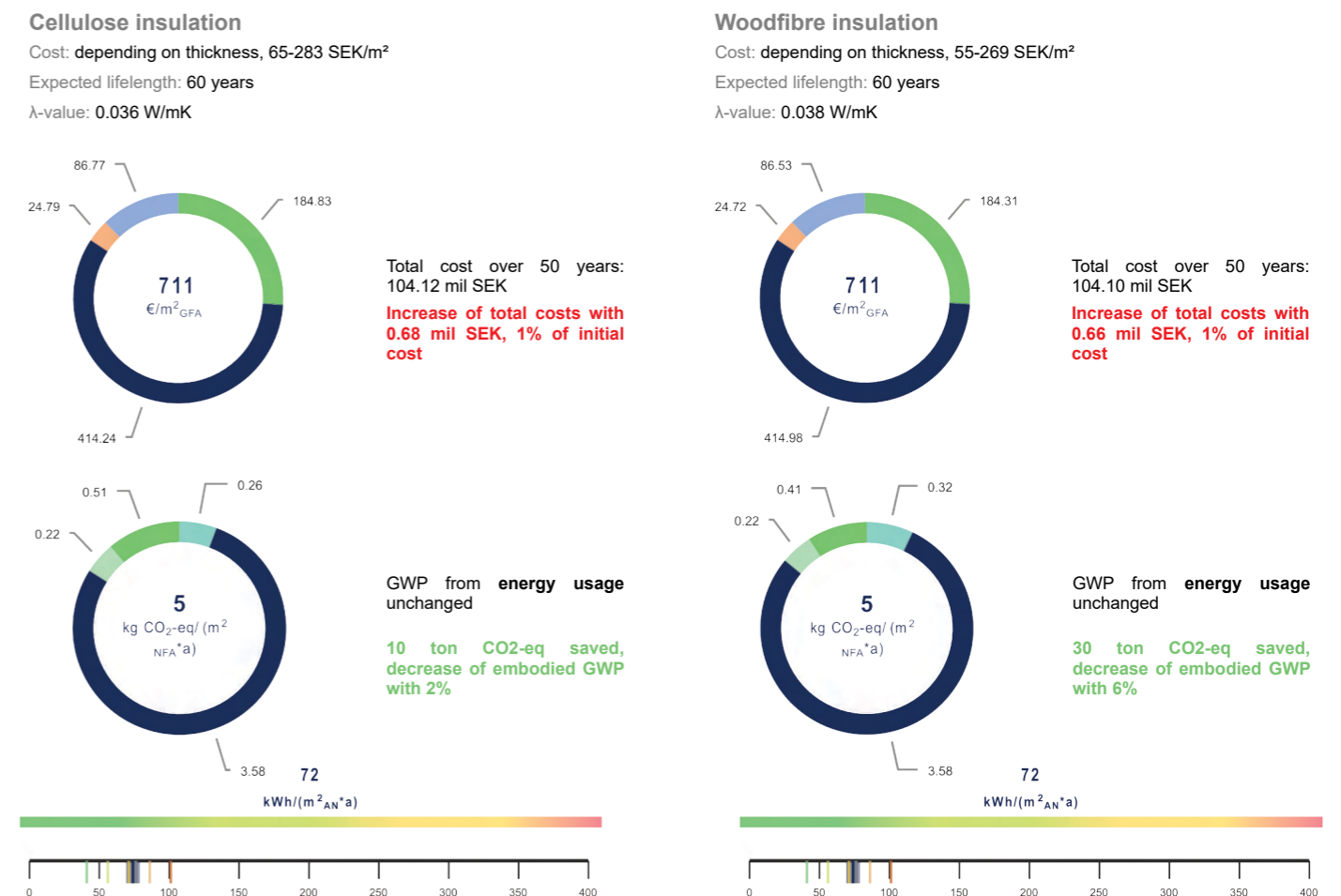
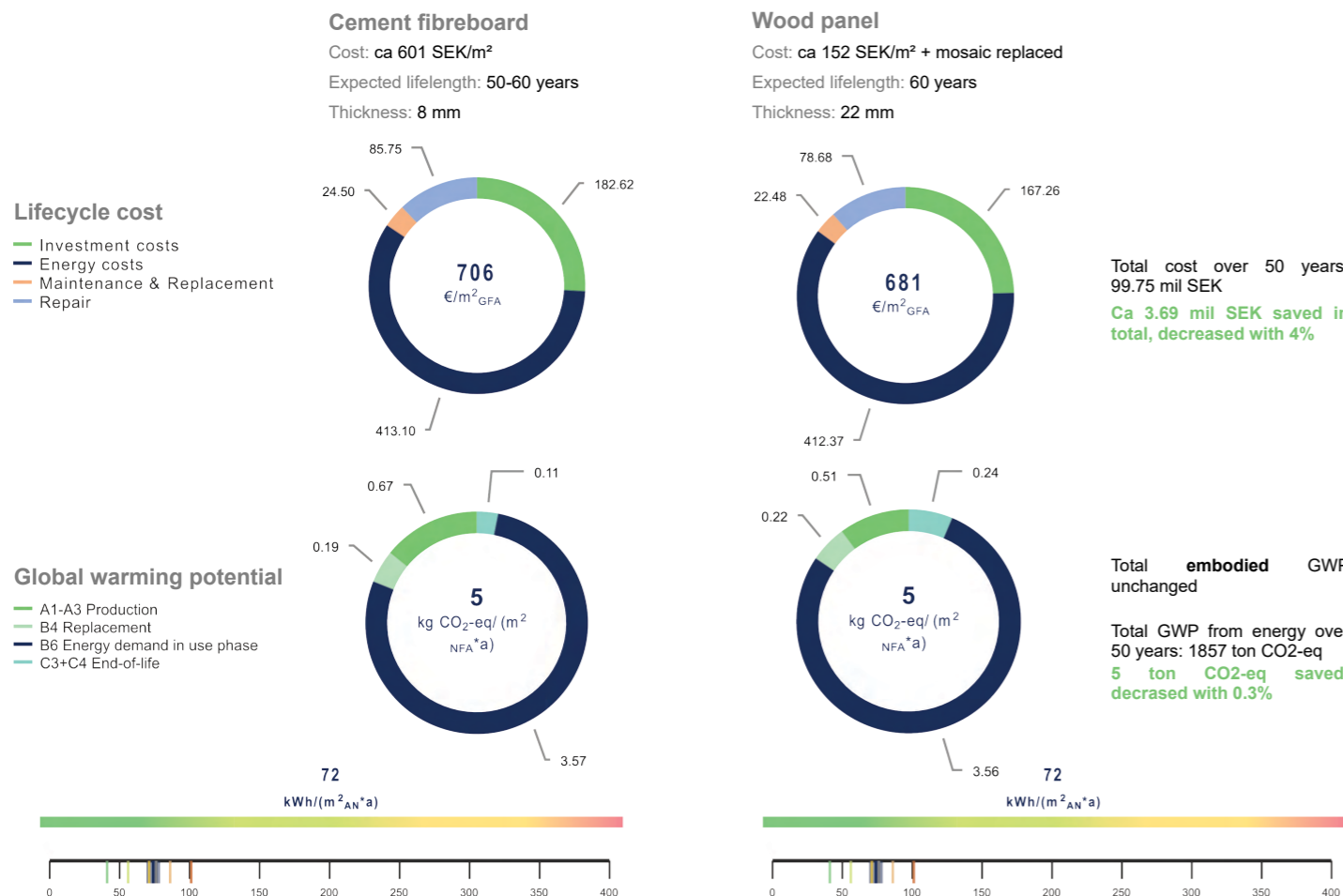

NEW DESIGN SUGGESTION

Floorplans, 1:400

Additional storage has been placed in the basement to accommodate for the added apartments. The old dressing rooms and common area previously used by staff have been left as a potential common area for tenants.

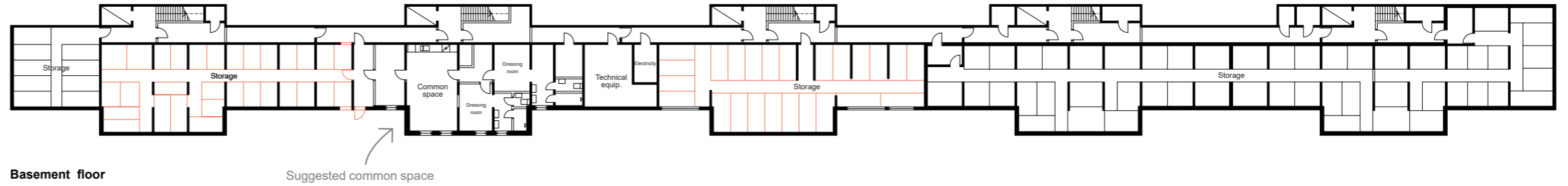

On the souterrain floor the new apartments have been placed in the previous storage areas. The old recycling rooms have received storage space since that part of the wall will be shaded by the upper floor. By creating openings in the walls some apartments could be merged to increase the diversity of apartment sizes. As an additional quality, balconies can be added to give all apartments a private outdoor space.

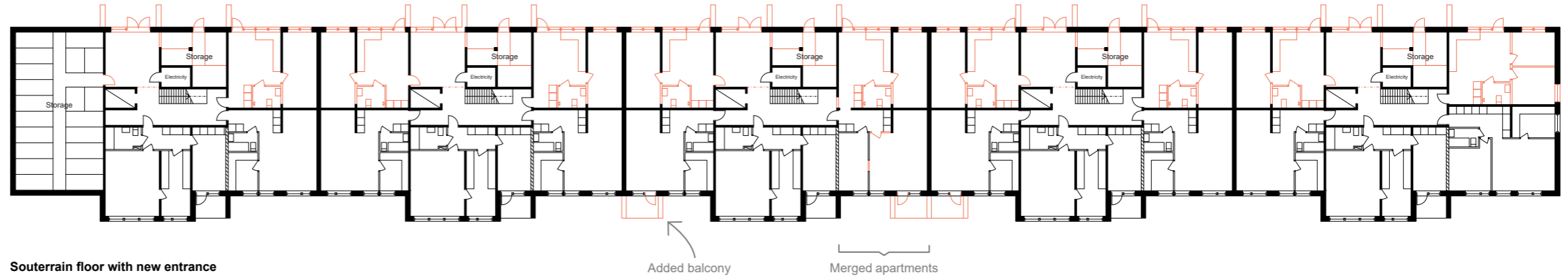

The old entrance floor has the same functions and layouts as before but by the previous entrances the floor has been removed for the double floor heights. The layouts are also maintained on floor 1 to 5. Some of the apartments can be merged by adding openings on these levels as well. The apartment dividing walls that have added insulation has been left untouched. By adding a new entrance to the balconies, the balcony would in some of the apartments be connected to the kitchen instead of a bedroom for improved quality.

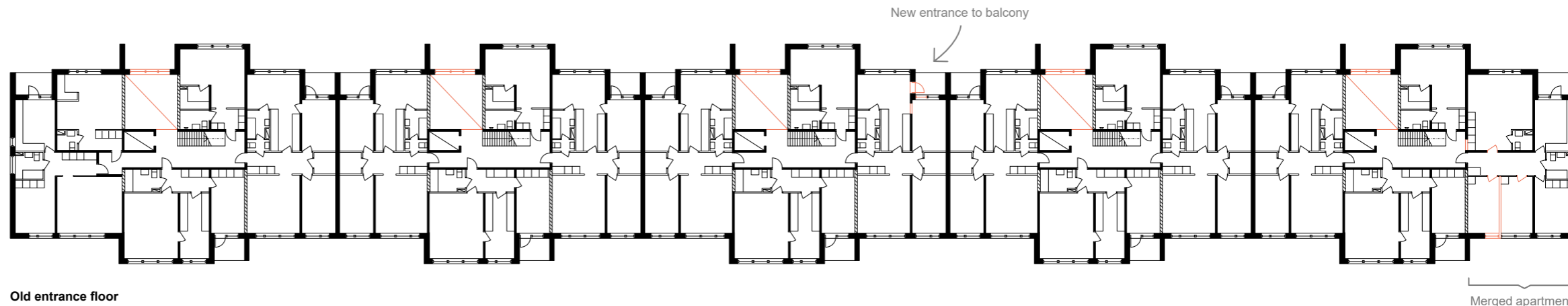

- Concrete and external walls
- Wooden walls
- Concrete walls + insulation
- Changes to the original construction

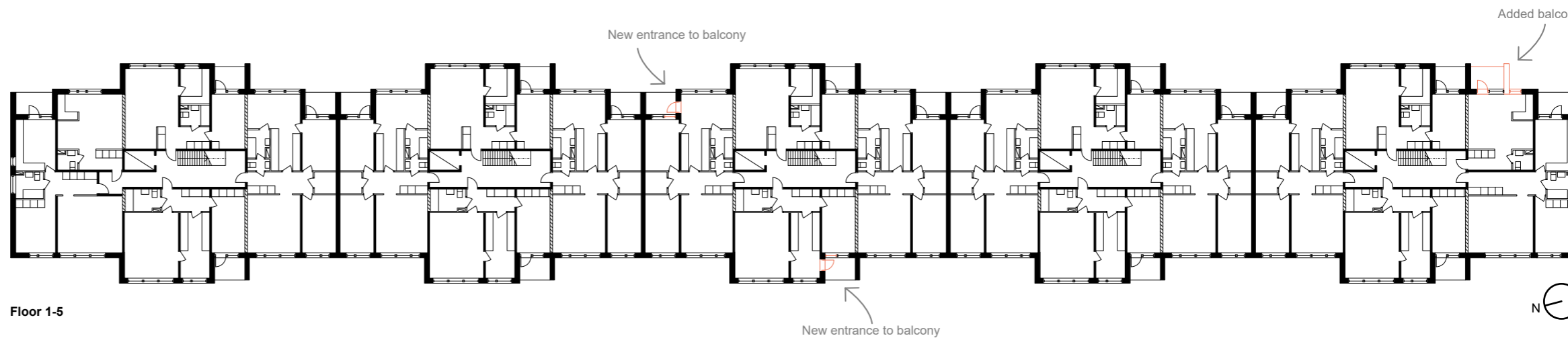

Facades, 1:400

In the new façades the rooftop extension and new entrances have been added. The existing roof has been reused and placed on top of the extension. The old mosaics are removed but could be replaced with new drawings on the wooden facades. This suggestion is of a more coherent façade expression and is using a neutral colour scheme, but the final colour is something that could be decided in conversation with the tenants.



Old facades, 1:800

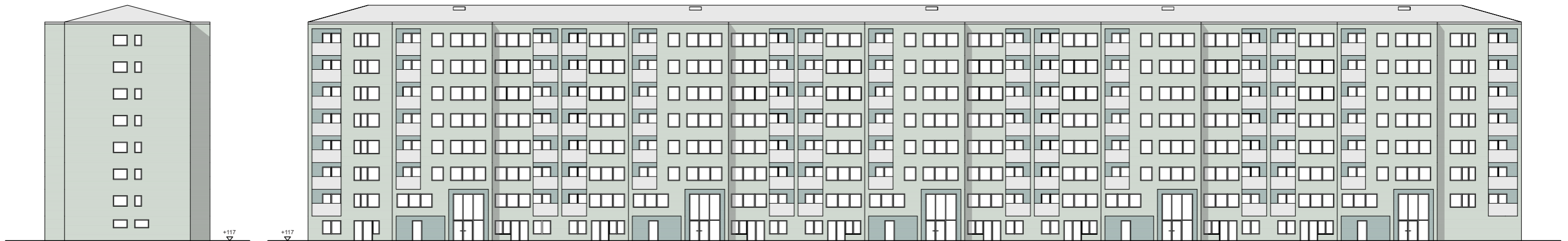

New facades, 1:400

FINAL RESULT

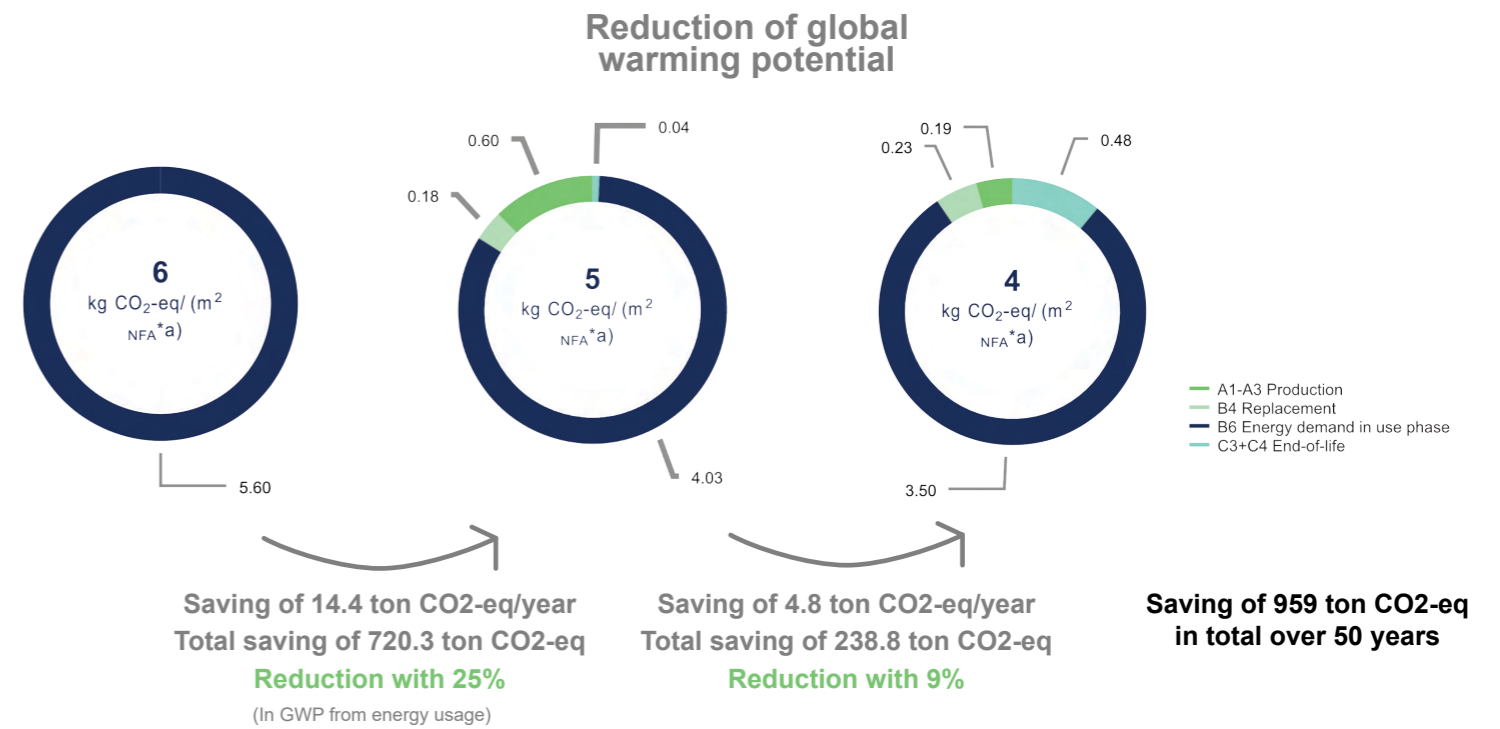
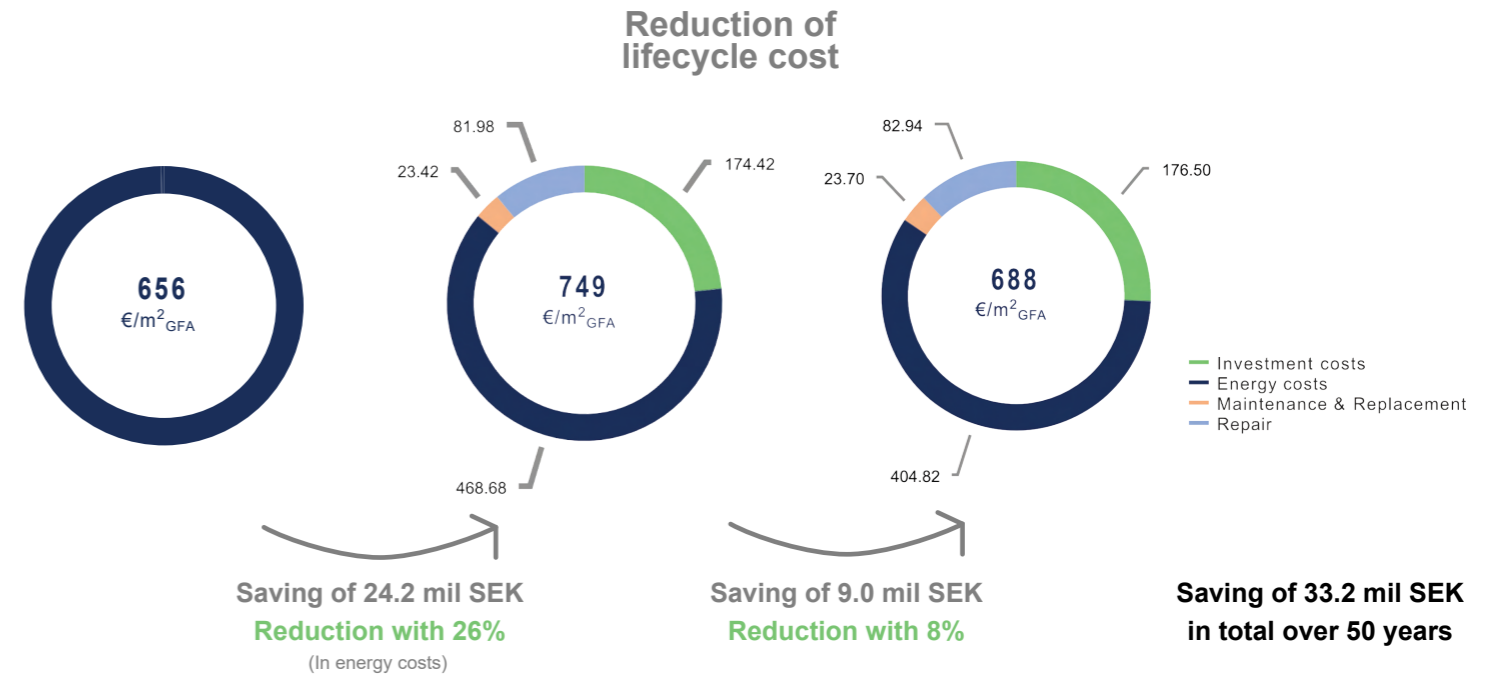
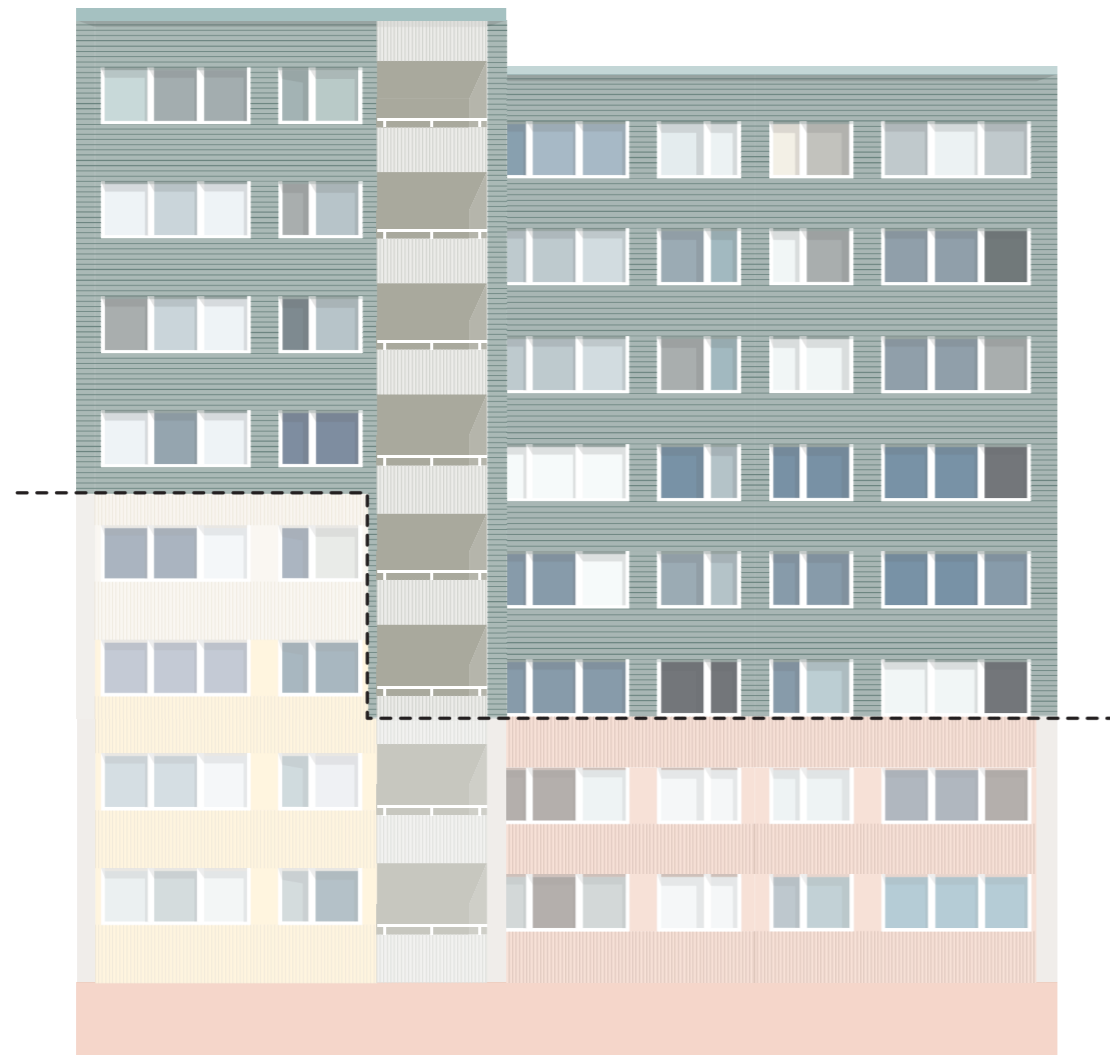

RENOVATION MEASURES

Insulation of souterrain floor

By removing the underground garage and adding insulation to the exposed wall as well as the floor, the global warming potential and cost and for energy could be reduced.
LCC: -2% LCA: -7% Primary energy demand: -10%

Change of construction method

By changing the steel construction to a wooden construction with less thermal bridges the investment cost and cost for energy was reduced along with the global warming potential.
LCC: -4% LCA: -1% Primary energy demand: -3%

Additional insulation

By adding insulation to some of the walls the global warming potential and energy usage was decreased. Percentually the lifecycle costs were unchanged.
LCC: --- LCA: -1% Primary energy demand: -1%

Change of facade material

By changing the façade material from cement fibre boards to a painted wooden façade the investment cost for the façade decreased.
LCC: -4% LCA: --- Primary energy demand: ---

Change of insulation material

By changing the stone wool insulation to wood fibre insulation boards, the global warming potential from the embodied carbon was reduced. This measure led to an increased investment cost.
LCC: +1% LCA: -6% Primary energy demand: ---

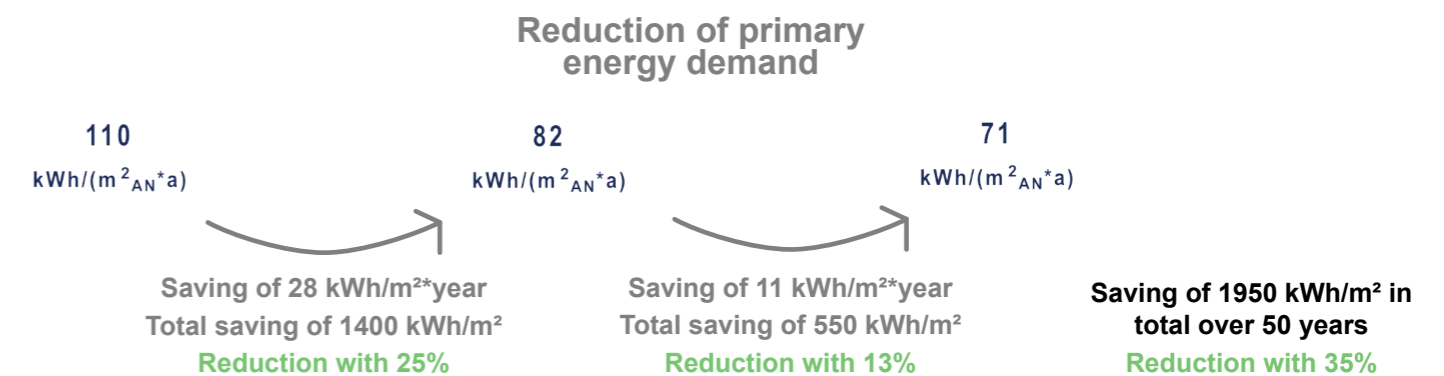

DISCUSSION

IN RESPONSE TO THE THESIS QUESTIONS

By extending a building's life length and lowering its energy usage, what are the possibilities to lower the cost and the environmental impact of a renovation while maintaining or improving on architectural qualities?

The result from the investigation reveals that the possibilities to impact differ between the investigated scales. The percentual difference between the original renovation and the unrenovated building is large. With the initial renovation and the main energy saving measures already performed, any further adjustments have a relatively small impact, but differences were still possible to be made.

LCA results

The largest difference in GWP was achieved with the insulation of the souterrain floor which lowered the energy usage. There was also a large difference in embodied carbon achieved from changing the insulation type. The rest of the changes had additional further reductions but at a smaller scale.

The low environmental impact from district heating in Sweden, combined with the relatively low amount of material changed in the renovation leads to overall small changes of global warming potential. In this case the investigated building also had a low form factor (with little exposed facade in relation to heated area) which lowered the energy loss through the facade in general. The test of individual materials made it possible to critically investigate the result on a detailed level but also automatically eliminated any choices of more expensive materials with lower embodied carbon that didn't lower the energy usage. To reach a building part with both lower cost and a significant lower embodied carbon, those materials were combined with more cost-saving strategies.

The switch from steel and cement-based materials to wood had a surprisingly low impact on the embodied carbon. A reason for this in the calculation could be the larger amount of wood used in comparison to the amount of the more CO₂ heavy materials. Wood is otherwise a material with both low embodied carbon and low investment costs. In a previous

project, RISE Research Institutes investigated the possibilities to use wooden modules in renovation projects such as this to lower the cost for construction (Rise, 2018). An alternative construction could also lead to a more efficient use of wood.

Worth mentioning in this case is that apart from the total GWP impact being low, the investigated building also had a large heated area. Since the LCA and LCC results were divided over the size of the investigated surface, small changes in decimals in the results lead to in comparison large savings of GWP and costs.

LCC results

Costs could be saved in the investigation from the energy saving measures, but the lower investment costs also had a large impact. Since CAALA calculates the maintenance and repair costs based on the DGNB system with a yearly %-increase based on the investment costs, the materials with high investment costs also got high maintenance costs. This got problematic since materials can have high costs initially and then low maintenance demands. A comparison between materials with low maintenance need and materials with high maintenance need, such as in the test between the cement fibreboards and the cheaper wooden facade, might not be realistic with this version of LCC. For the construction test, the wooden material was also initially cheaper in comparison to the aluminium mounting system, which lead to further lower maintenance cost. In this case it could however be assumed that the wood will have a similar level of maintenance need as the aluminium since it is protected by the facade.

Another conclusion from the investigation is that it is worth looking at cost saving measures beyond the LCC. The total income of 30.6 mil SEK from the added extension apartments over 50 years is almost the same amount as what was saved from the renovation. By also adding apartments on the souterrain floor, without considering the demolition and construction of a new garage, there would be an additional income of around 14.5 mil SEK.

Architectural qualities

In the investigation some architectural qualities could be added in direct relation to the lower environmental impact and lower long term costs. With the demolition of the garage and insulation of the souterrain floor the entrances could get improved with a double floor high and the staircases made a bit brighter. It could also be argued that the change into a wooden facade would create a warmer and less industrial feeling to the area.

The suggested changes to the apartments were added with intent to have them economically supported using the excess costs from the renovation. In reality, the utility value principle will make changes that improves the apartment qualities impossible without also increasing rents.

In previous renovations the addition of spaces possible for appropriation for tenants were considered a large quality and have in previous cases in Sweden been delegated to common spaces. In areas with overcrowding such as this, the common spaces could also get an increased importance since they can function as an extension of the apartment. While the renovated yard in this project creates outdoor meeting places, a large part of the year in Sweden has a cold and dark climate where it is difficult to stay outside. An indoor common space could be used all year round and further improve the quality for the tenants. In this thesis the opportunities of common spaces are not investigated in depth but an area in the building was left unchanged as a potential space for further development.

Communication with tenants is vital for a successful and socially sustainable project. In this thesis creative freedom was taken to create a final product, but if performed, decisions should be discussed with tenants. The colours of the buildings and alternative facade expressions could for example be adapted to fit results from a tenant workshop or poll like it was in the previous renovations.

Can lower lifecycle costs be motivation for choosing environmentally sustainable solutions in the building sector?

The result from the investigation in this thesis indicates that environmentally sustainable measures can be done while also achieving long term lower costs. The question is whether the data provided from an LCC will be considered accurate enough to actually have an impact on decisions. With the initiation of the climate declaration law in Sweden and the demanded for an LCA, there might be an increased interest in using the lifecycle method for calculating impact. With an increased understanding of the method and real-life successful examples, the results from an LCC could in the future have increased chances to determine decisions.

Can lower lifecycle costs of a building be used as motivation for setting lower rents?

From the background investigation it was indicated that long-term savings in costs have previously been used to set lower rents. In the project example described by Kurvinen (2020) the project discrepancy period could be extended and connected to the required rate of return which led to lower rents. In this project the time scope got limited to 50 years. For impact on the rents there might be a need to investigate the costs of the renovation over longer time span and provide stronger assurance of the material's life lengths. It comes down to a needed willingness of the client to take a potential risk for the method to be utilized.

The low cost of the project described by Kurvinen was also

dependent on state subventions. At the time of this thesis many of the subventions related to renovation and energy saving have recently been removed. These actions seem to indicate that there is a reduced political interest to create socially sustainable housing in Sweden. With 15-18% of the production costs expected to be for VAT, it raises the question of where the VAT from the building sector is spent instead.

In discussion with Familjebostäder it was made clear that the only determinant of the rent is the utility value and therefor lower long-term costs won't have any impact. In this project it can hence be stated that it wouldn't be possible to use the lower life cycle costs to set lower rents. On one hand the utility value principle makes sure that there can't be high rents for low quality housing. On the other hand, the principle can cause increases in rents for measures that could pay for themselves. For example, while generally not a by large amount, rents could increase rent for improved indoor climate after insulation of the facades. This raises the question of what should count as a quality improvement and what should be considered standard. If the standard increase for technical renovations just simply were removed than the motivation to perform the renovations at all would decrease. There seems to be a change needed on a larger scale where if the standard is set at a higher level, governmental support would be needed. Especially in the case of public housing companies that have a larger social responsibility compared to private housing companies. Considering the removal of subventions, it seems however as if the current change is moving in the opposite direction.

PROCESS REVELATIONS

Actual economic impact

The final cost savings were towards the end of the project discussed together with Familjebostäder. In this project it was assumed that the costs of doing nothing would outweigh the investment costs for the renovation which is not how the profitability would be calculated. The new investment cost after the adjustments ends up being around 25.9 mil SEK and removing that from the saved 33.2 mil SEK results in a final profit of 7.3 mil SEK. Divided over the 50-year period and the gross housing area the reduction in operational costs would end up at 16 SEK per year and square meter. The total savings would then only reduce the operational costs with 3%.

To have a larger impact in the future, measures beyond the investigation in this thesis could be made. For example, insulation of the basements or further investigation of the attic insulation could be done. As previously mentioned, there could also be further investigation into the impact from ventilation with heat recovery. Additionally, the increase of future energy costs could be set to a conservative value in this investigation and energy saving measures could have a higher impact on reducing costs than shown here.

Level of detail in the simulation

In the investigated building there were a large variety of wall types with different construction methods. Adding these wall types into separate layers took a lot of time when materials were changed in the later tests. In another project the test could potentially be simplified by only changing the most impactful building parts. In this building however there were a low amount of material changed and doing the test on an even smaller part of the building might end in results that barely show any difference. With better knowledge of environmental impact and costs from the start, some of the walls could potentially instead be replaced with a general construction to lower the amount of wall types. In this case it could for example maybe be simplified to only a concrete wall type and a wood wall type.

Cost for work

In the investigation of this thesis no consideration was done to the cost for the work connected to running the LCA and LCC calculations. LCA tools usually only demands a small investment fee or are completely free to use, the main costs are instead connected to the time needed to run them (Beemsterboer, 2019). In previous cases it has been experienced that a big part of the time is spent collecting the data needed for the simulation. While the calculations demand a large set of data, the actual time spent running the simulation is short.

In this project the costs provided for materials were separated from the costs for working hours, which was gathered in a single clump sum. This was not an issue in the test of the original renovation performance but became problematic in the tests where separate building parts were

exchanged. By using average costs for work hours an estimation could still be made but the calculations took time to do. This issue might not be usual in the industry, but it exemplifies the issue of information collection when it comes running LCA and LCC. To reduce the work time and make performance of LCA and LCC cheaper there needs to be awareness of what data is needed and streamlining of the data collection.

Life lengths - in theory and reality

In the product information of the cement fibreboards, it was stated that their lifetime was expected to be 30-60 years. This would potentially give them a shorter lifetime than that of painted wood panels. In Boverket's climate database the life length was instead set to that of the building part, and it was stated that the material would last at least longer than 50 years. For wood the sources on life length differed depending on the quality and maintenance of the material. In projects of this scale where there is limited material to change, it could be beneficial to do a deeper investigation of the material properties. A better knowledge of the material's functionality and an increased assurance of the construction's life length would improve the lifecycle calculation's accuracy and could also create potential to lengthen the investigated lifetime. Especially in the case of wood where the longevity of the material seems to be questioned.

In this thesis the durability of wood was assumed to be 60 years, but the wooden façade could need more maintenance than shown in the results. As an alternative to the painted spruce panels, it would be interesting to explore if the investment in more durable untreated wood would be profitable if the building was assumed to last for another 50 years.

Impact from energy usage

During the determination of primary energy factors used in CAALA, different values were suggested for representing the district heating and electricity impact. The values from the energy company gave significantly lower primary energy demand compared to the values used for energy certification stated by Boverket. There also seems to be a gap between the low global warming potential and the high primary energy demand. Potentially the Swedish certification system for energy needs to be updated to accurately represent the energy usage's actual environmental impact.

With further development of clean energy, it could seem as if energy saving measures would be pointless in the future. It however needs to be considered that also energy from environmentally friendly sources have a resource demand and could have an impact beyond the scope of CO2 releases. The quality of energy could also change for the worse in the future. Energy saving measures and increased energy independence is hence a good method to ensure a profitable building with low environmental impact also in the future.



Figure 32



Figure 33



REFERENCES

- Ahlberg, H. (2022). *Här är finalisterna i tävlingen om Årets bästa renovering!*. Sveriges Allmännyttan. <https://www.sverigesallmannytta.se/har-ar-finalisterna-i-tavlingen-om-arets-basta-renovering/>
- Beemsterboer, S. (2019). *Simplifying LCA use in the life cycle of residential buildings in Sweden*. [Licentiate thesis, Chalmers University of Technology]. Chalmers Reproservice. <https://research.chalmers.se/publication/512280>
- Boverket. (2019). *LCA vid ombyggnad*. <https://www.boverket.se/sv/byggande/hallbart-byggande-och-forvaltning/livscykelanalys/lca-i-byggprocessen/lca-vid-ombyggnad/>
- Boverket. (2019). *Miljöcertifieringssystem och LCA*. <https://www.boverket.se/sv/byggande/hallbart-byggande-och-forvaltning/livscykelanalys/miljocertifieringssystem-och-lca/>
- Boverket. (2023). *Utsläpp av växthusgaser från bygg- och fastighetssektorn*. <https://www.boverket.se/sv/byggande/hallbart-byggande-och-forvaltning/miljoindikatorer---aktuellt-status/vaxthusgaser/>
- Boverket. (2019). *Vilka mervärden ger en LCA?*. <https://www.boverket.se/sv/byggande/hallbart-byggande-och-forvaltning/livscykelanalys/vilka-mervarden-ger-lca/>
- Energimyndigheten. (2023). *Scenarier över Sveriges energisystem 2023, Med fokus på elektrifieringen 2050* (ER 2023:07, revised edition). Statens energimyndighet. <https://energimyndigheten.a-w2m.se/Home.mvc?ResourceId=213739>
- Familjebostäder. (2021). *Förstudie, Projekt – Gärdsås invändigt etapp 1-4* (Project No.60320).
- Femenías, P. Gluch, P. Mjörnell, K. (2018). *Utmaningar för hållbar förnyelse, En studie av miljonprogramsområdet Siriusgatan* (nr: 1). CMB.
- Gårdstensbostäder (n.d.). *Solhusen i Gårdsten*. <https://docplayer.se/4259035-Sol-husen-i-gardsten-solhusen-i-gardsten.html>
- Hamon, S. Horgby, C. Pettersson, M. Victorsson, C. Wilson, J. (2016). *Åtgärdsprogram för hållbar utveckling av Gärdsås Höjd*. Familjebostäder i Göteborg.
- Hollberg, A., Klüber, N., Schneider, S., Ruth, J., Donath, D. (2016). *A Method for evaluating the environmental life cycle potential of building geometry. Expanding Boundaries, Systems Thinking in the Built Environment*. <http://vdf.ch/expanding-boundaries.html>
- Jaxmark, K. (2017). *Kristallkuben på Siriusgatan*. Familjebostäder.
- Johansson, M. (2017). *Renoveringskompetens*. (SBUF, ID: 13391). Industrifakta AB. <https://vpp.sbuf.se/Public/Documents/ProjectDocuments/0d7bdf32-a47a-4a9a-89d4-5ff4846b8856/FinalReport/SBUF%2013391%20Slutrapport%20Renoveringskompetens.pdf>
- Johansson, E. (2021). *Cheaper but better*. [Master thesis, Chalmers University of Technology].
- Jonsson, T. Stiller, N. (2016). *Business models in sustainable public housing renovation*. [Master thesis, Chalmers University of Technology].
- Kortspelet Klimatkoll. *FLYGRESA Stockholm–Göteborg*. <https://www.kortspeletklimatkoll.se/berakningar/transport/baksida-flyg1/>
- Kruit, K., Vendrik, J., van Berkel, P., van der Poll, F., Rooijers, F. (2020). *Zero Carbon Buildings 2050: Summary report*. CE Delft. <https://europeanclimate.org/content/uploads/2020/07/ecf--buildings-netzero-fullreport-v11-pages-lo.pdf>
- Kurvinen, A. (2020). *Lönsamhetskalkyl för hållbart byggande*. Studentlitteratur
- Lacaton & Vassal. (2017). *Transformation de 530 logements, bâtiments G, H, I, quartier du Grand Parc - Lacaton & Vassal, Druot, Hutin, Transformation of 530 dwellings, block G, H, I*. <https://www.lacatonvassal.com/index.php?idp=80#>
- NL Architects. (n.d.). *Kleiburg*. <http://www.nlarchitects.nl/slideshow/201/>
- Offentliga fastigheter (2022). *LCA och LCC i tidiga skeden*. Sveriges Kommuner och Regioner. <https://skr.se/download/18.583b3b0c17e40e30384af41e/1643292115464/LCA-och-LCC-i-tidiga-skeden.pdf>
- Rise Research Institutes. (2018). *Klimatskal i trä sparar tid, pengar och energi*. <https://www.ri.se/sv/berattelser/klimatskal-i-tra-sparar-tid-pengar-och-energi>
- Rival. (n.d.). *Varför återbruksinventering?*. <https://www.rivare.nu/aterbruksinventering/>
- SCB. (2023). *Elnätspriser för olika typkunder, tidsserie*. <https://www.scb.se/hitta-statistik/statistik-efter-amne/energi/prisutvecklingen-inom-energiomradet/elpriser-och-elavtal/pong/tabell-och-diagram/tabeller-over-arsvarden/elnaetspriser-for-olika-typkunder-1996/>
- SCB. (2022). *Prisbasbeloppet för år 2023*. <https://www.scb.se/hitta-statistik/statistik-efter-amne/priser-och-konsumtion/konsumentprisindex/konsumentprisindex-kpi/pong/statistiknyhet/prisbasbeloppet-for-ar-2023/>
- SCB. (2022). *Byggbkostnadsutvecklingen* (pr0502_2022m12_1910_kalldata_sv) [Dataset].
- SCB. (2018). *Kostnader per kvm för nybyggda ordinära flerbostadshus efter region, upplåtelseform och brutto-/nettokostnad. År 1994 – 2017*. https://www.statistikdatabasen.scb.se/pxweb/sv/ssd/START__BO__BO0201__BO0201N/KostnaderPerAreorFH4/
- SCB. (2023). *Byggbkostnadsindex (BKI) för bostäder inkl. löneglidning, 1968=100 efter hustyp, kostnadsslag och år*. https://www.statistikdatabasen.scb.se/pxweb/sv/ssd/START__PR__PR0502__PR0502B/FPIInLgAr/table/tableViewLayout1/
- SCB. (2017). *Intäkter och kostnader för flerbostadshus (IKU), allmännyttiga bostadsföretag efter region, lägenhetsantal och intäkts-/kostnadsslag*. https://www.statistikdatabasen.scb.se/pxweb/sv/ssd/START__BO__BO0301__BO0301A/IKUKommloK/
- SCB. (2017). *Intäkter och kostnader för flerbostadshus (IKU), allmännyttiga bostadsföretag efter region, lägenhetsantal och intäkts-/kostnadsslag*. https://www.statistikdatabasen.scb.se/pxweb/sv/ssd/START__BO__BO0301__BO0301A/IKUKommloK/
- SCB. (2023). *Konsumentprisindex (KPI) fastställda årsmedeltal, totalt, 1980=100 efter år*. https://www.statistikdatabasen.scb.se/pxweb/sv/ssd/START__PR__PR0101__PR0101A/KPIFastAmed/table/tableViewLayout1/
- Slessor, C. (2019). *Reuse – Rhabillé. Architects Journal*. https://www.lacatonvassal.com/data/documents/20191008-14225819_Architects%20Journal_compressed.pdf
- Stadsbyggnadskontoret. (2022). *Detaljplan för bostäder vid Siriusgatan inom stadsdelen Bergsjön* (Project No.0678/13). Göteborgs Stad.
- Stenberg, J. (2020). *The zero option – tenant experiences from an experiment to renovate apartments without increasing rent*. Cogent Social Sciences 6: 1848500, <https://doi.org/10.1080/23311886.2020.1848500>
- Svensk Ventilation. (n.d.). *FTX – Ventilation med värmeåtervinning*. <https://www.svenskventilation.se/ventilation/olika-satt-att-ventilera/ftx-varmeatervinning/>
- Söderman, J. (2017). *Tillståndsbedömning av parkeringsgarage, Siriusgatan 78-120, Bergsjön* (Project No.743021). ÅF-Infrastructure.
- Träguiden. (2019). *Livscyklar för träkonstruktioner*. <https://www.traguiden.se/underhall/ytbehandling-och-underhall/ytbehandling-och-underhall--generellt/ytbehandling/livscyklar-for-trakonstruktioner/>

IMAGES

Any unmarked figures are either personal images, images from CAALA reports or images from the original drawings of the investigated building and site.

Figure 1: Kurvinen, A. (2020). *Lönsamhetskalkyl för hållbart bostadsbyggande*. (p.35)

Figure 2: Kurvinen, A. (2020). *Lönsamhetskalkyl för hållbart bostadsbyggande*. (p.37)

Figure 3: Kurvinen, A. (2020). *Lönsamhetskalkyl för hållbart bostadsbyggande*. (p.51)

Figure 4: Jonsson, T. Stiller, N. (2016). *Business models in sustainable public housing renovation*. [Master thesis, Chalmers University of Technology].

Figure 5: Boverket/SCB. (2023). *Utsläpp av växthusgaser från bygg- och fastighetssektorn*. <https://www.boverket.se/sv/byggande/hallbart-byggande-och-forvaltning/miljoindikatorer---aktuell-status/vaxthusgaser/>

Figure 6: Boverket/SCB. (2018). *Minskad klimatpåverkan från flerbostadshus – LCA av fem byggsystem*. IVL-Rapport. (p.344)

Figure 7: Adalberth, K. (n.d). [LTH].

Figure 8: Erlandsson, M. Larsson, M. Malmqvist, T. Kellner, J. (2016). *BYGGANDETS KLIMATPÅVERKAN FÖR ETT FLERBOSTADSHUS MED YTTERVÄGG OCH STOMME AV KORSLIMMAT TRÄ – KVARTERET STRANDPARKEN*.

Figure 9: Offentliga fastigheter. (2022). *LCA och LCC i tidiga skeden* p.(10).

Figure 10: Hollberg, A. (2022). Personal communication. (p.10). Modified by author

Figure 11 & 12: Hollberg, A. (2020). *CAALA modellering tips*. <http://link.springer.com/10.1007/s40974-017-0056-9>

Figure 13-19: Gårdstensbostäder. *Solhusen i Gårdsten*. <https://docplayer.se/4259035-Sol-husen-i-gardsten-solhusen-i-gardsten.html>

Figure 20: Slessor, C. (2019). *Reuse – Rhabillé. Architects Journal*. (p.35). https://www.lacatonvassal.com/data/documents/20191008-14225819_Architects%20Journal_compressed.pdf

Figure 21: Slessor, C. (2019). *Reuse – Rhabillé. Architects Journal*. (p.41). https://www.lacatonvassal.com/data/documents/20191008-14225819_Architects%20Journal_compressed.pdf

Figure 22: Slessor, C. (2019). *Reuse – Rhabillé. Architects Journal*. (p.42). https://www.lacatonvassal.com/data/documents/20191008-14225819_Architects%20Journal_compressed.pdf

Figure 23: Druot, F. Hutin, C. Lacaton, A. Vassal J, P. (2016). *Transformation des bâtiments Gounod, Haendel et Ingres, quartier du Grand Parc, Bordeaux*. (p.2). Modified by author. https://www.lacatonvassal.com/data/documents/20181214-165201LV_FchA4_HabitatTransfo_GRP_bd.pdf

Figure 24: van der Burg, M. (2017) *Gallery of NL Architects and XVW Architectuur's deFlat Wins 2017 EU Prize for Contemporary Architecture - Mies van der Rohe Award - 4* (archdaily.com)

Figure 25-28: NL Architects. (n.d.). <http://www.nlarchitects.nl/slideshow/201/>

Figure 29: van der Burg, M. Brakkee, S. Poelstra, S. (n.d.). <https://www.xvwarchitectuur.nl/kleiburg>

Figure 30: Femenías, P. Gluch, P. Mjörnell, K. (2018). *Utmaningar för hållbar förnyelse, En studie av miljonprogramsområdet Siriusgatan* (nr: 1). CMB. (p.12). Modified by author.

Figure 31: Hamon, S. Horgby, C. Pettersson, M. Wictorsson, C. Wilson, J. (2016). *Åtgärdsprogram för hållbar utveckling av Gårdsås Höjd*. Familjebostäder i Göteborg. (p.8). Modified by author.

Figure 32: Familjebostäder. (2022). *Gårdsås Utgångsläge* (p.2).

Figure 33: Familjebostäder. (n.d.). *Gårdsås områdesutveckling Etapp 1* (p.4).

Figure 34: Familjebostäder. (2022). *Gårdsås Utgångsläge* (p.13).

Figure 35: Göteborg stad. (2022). *Detaljplan för bostäder vid Siriusgatan inom stadsdelen Bergsjön i Göteborg*. [https://www5.goteborg.se/prod/fastighetskontoret/etjanst/planobygg.nsf/vyFiler/Bergsj%C3%B6n%20-%20Bost%C3%A4der%20vid%20Siriusgatan-Plan%20-%20inf%C3%B6r%20antagande-Plankarta/\\$File/1.%20Plankarta%20med%20planbest%C3%A4mmelser.pdf?OpenElement](https://www5.goteborg.se/prod/fastighetskontoret/etjanst/planobygg.nsf/vyFiler/Bergsj%C3%B6n%20-%20Bost%C3%A4der%20vid%20Siriusgatan-Plan%20-%20inf%C3%B6r%20antagande-Plankarta/$File/1.%20Plankarta%20med%20planbest%C3%A4mmelser.pdf?OpenElement). Modified by author.

Figure 36: Stadsbyggnadskontoret. (2022). *Detaljplan för bostäder vid Siriusgatan inom stadsdelen Bergsjön*. [https://www5.goteborg.se/prod/fastighetskontoret/etjanst/planobygg.nsf/vyFiler/Bergsj%C3%B6n%20-%20Bost%C3%A4der%20vid%20Siriusgatan-Plan%20-%20inf%C3%B6r%20antagande-Planbeskrivning/\\$File/2.%20Planbeskrivning.pdf?OpenElement](https://www5.goteborg.se/prod/fastighetskontoret/etjanst/planobygg.nsf/vyFiler/Bergsj%C3%B6n%20-%20Bost%C3%A4der%20vid%20Siriusgatan-Plan%20-%20inf%C3%B6r%20antagande-Planbeskrivning/$File/2.%20Planbeskrivning.pdf?OpenElement)

Figure 37: Svensk Ventilation. (2018). *Jämförelse av FX- och FTX-system för ventilation av flerbostadshus* (p.6).

Figure 38: LEIAB Fönster (n.d). *Produktblad Haga* (p.1). <https://www.leiab.se/produkter/p/haga/kipp-dreh-fonster/lkf1001ye--inatgaende-kipp-dreh-fonster-2-1-glas/>

Figure 39: HILTI. (n.d.). *VENTILATED FACADES Technical Manual Panels and systems* (p.6). <https://www.hilti.se/content/hilti/E1/SE/sv/business/business/engineering/eurofox.html>. Modified by author.

Figure 40: Rockwool. (n.d.). *Tilläggsisolering utvändigt med Västkustskiva*. <https://www.rockwool.com/se/produkter-och-konstruktioner/yttervagg/betong/>

