



OBSERVING AND ANALOG PROCESSES

ENGAGING IN ARCHITECTURE
TROUGH A PHENOMENOLOGICAL PRACTICE

MICHAEL GATES CARLSSON

Master's Thesis at Chalmers School of Architecture,
Department of Architecture & Civil Engineering
Master's Programme Architecture and Urban Design
2023

Examiner: Daniel Norell
Tutor: Peter Christensson

Observing and Analog Processes
Engaging in architecture through a phenomenological practice

Michael Gates Carlsson
Chalmers School of Architecture,
Department of Architecture & Civil Engineering
Master Thesis in Architecture and Urban Design
Matter Space Structure

Gothenburg, Sweden 2023

Examiner: Daniel Norell
Tutor: Peter Christensson



CHALMERS

THANK YOU

Peter Christensson
Daniel Norell

ABSTRACT

The purpose of this thesis is to explore an analog design process and how it could deepen a sensory relationship to architecture, both in the way we analyze it and how we assign it a speculative form. My question is: What sets analog design processes apart from other design modes, and what could analog drawing techniques contribute in an increasingly digital context? Would it be possible to better engage human agency and, thus, put ourselves into a more deliberate relationship with the surrounding physical world by better taking human bodily consciousness into account, the basic physical predicament described by phenomenology?

My starting point will be the texts of Juhani Pallasmaa, specifically those related to the intersection of phenomenology and architecture. Both philosophers and architects have criticized the rational type of thinking that paved the way for the blessings of modernity, and, at the same time demystified (and perhaps dehumanized) our perceptions of the world. The jumping-off point for this thesis is a look at what could be learned from adopting a more bodily oriented design process by means of analog methods, hand drawing and model making. The theoretical framework for my project builds on the subject of architectural phenomenology and I intend to take this opportunity to dig deeper into the publications of Juhani Pallasmaa and Gaston Bachelard, among others.

On a practical level the aim of my thesis is to design a hermitage starting with analog recordings of the chosen site and explore modes of drawing. The goal is to design a building large enough to accommodate one or two people for roughly 5 days. This typology or building will be of a suitable scale to serve as the point of departure for my exploration of the questions raised in this thesis. In a contemporary setting this typology could support a more general phenomenological reflection over life, diving deeper into the bodily experience of existing in space and in the world at large.

INDEX

| | |
|-------------------------------------|-----------|
| INTRODUCTION | 9 |
| Student background | 11 |
| Background | 12 |
| Research questions | 13 |
| Purpose | 13 |
| Method | 14 |
| Theory | 15 |
| Delimitations | 15 |
| Reading instructions | 16 |
| | |
| THEORETICAL INVESTIGATIONS | 19 |
| Architecture as a cultural practice | 20 |
| Miniatures and representation | 24 |
| Transformation | 26 |

| | |
|--------------------------------|-----------|
| PHYSICAL INVESTIGATIONS | 29 |
| Charcoal studies | 30 |
| The drawing device | 34 |
| | |
| DESIGN PROCESS | 42 |
| Drawing forth meaning | 44 |
| Three chosen characters | 52 |
| The Beehive | 54 |
| The House | 58 |
| The Monolith | 62 |
| | |
| A FINAL DESIGN PROPOSAL | 68 |
| | |
| DISCUSSION | 75 |
| | |
| BIBLIOGRAPHY | 78 |

INTRODUCTION

STUDENT BACKGROUND

Bachelor of Architecture
Aarhus School of Architecture
August 2017 - June 2020

Masters of Architecture
Chalmers University of Technology
August 2021 - June 2023

Internship
Kjellgren Kaminsky
January 2020 - June 2020

Work
Kjellgren Kaminsky / Kaminsky Arkitektur
August 2020 - January 2021
Augusti 2022 - December 2023

BACKGROUND

The cultural potential of art and architecture strikes me as the great potential in architecture. It is perfectly possible to design and make houses without architects. Vernacular buildings are often designed without the need for architects. There is also a global trend with architecture firms being bought by engineering firms, and discussions about the design process being automated by AI. Making more efficient workflows, integrating instantaneous analyses is a focus area for most larger architectural firms.

Setting these commercial and pragmatic needs of architectural firms aside, phenomenology points to a greater architectural achievement. One way of looking at it is that the potential of the architect it's not only the actual house in itself, but the arrangement of materials and in doing so framing/ contextualizing space, participating as a cultural agent making meaning from meaninglessness. Renato Rizzi (2016) points out that the word 'architecture' can be traced to a combination of the Greek word *arkhi*, a derivative of the word *'arkh' e* or 'beginning' in English and another Greek word, *'téktōn'*, or creator, alluding either to the role of 'chief creator' or, possibly, the one who drags the underlying principles into the light of day, thereby creating meaning. The word 'draw' has a close relationship to the concept of drawing, pulling, and making, as in extracting meaning. It has to be pointed out that these are just notations, perhaps mere coincidences, but they nevertheless point towards the poetical potential of architecture.

I consider it useful to acknowledge humans as bodily beings, not just mere rational minds somehow separated from, and only residing in the shell of a body. Perhaps it is only possible to achieve a certain type of result via a process of artificial rationalization. But there are also significant parts of the human predicament that can only be approached by engaging in the analog processes associated with a real life. The digital space might have opened a host of alternative realities and parallel spaces, but we are (for the time being) still situated in our physical body. No matter how far we expand our technical horizons we are still right here in our physical skins, leaving us with the need to create meaning anchored in the physical space we inhabit. By taking explicit account of this reality, I believe there is still improvement that can be made by taking a more hands-on approach that is rooted in human lives as they are lived in the midst of the material world that surrounds us. We need to become more active agents in our physical life, and not just digital consumers and producers.

In the words of Peter Zumthor (2006), the creation and study of atmosphere comes down to an engagement with the physical craft of architecture: "... the idea that the task of creating an architectural atmosphere also comes down to craft and graft. Processes and interests, instruments and tools are all part and parcel of my work" (p.75). In this light, Zumthor's drawings in coal and pastel demonstrate a convincing way to explore atmosphere. His work with analog sketches and models seems to support a greater sense of weight and light, where traces of the chosen medium are allowed to convey and enhance spatial qualities.

RESEARCH QUESTIONS

What sets an analog design process apart from other modes of design, and what can analog drawing contribute in an increasing digital context?

PURPOSE

By deepening my own understanding of phenomenological theory in the field of architecture, and by putting my own work in relation to theories of the body-mind perspective, I will also wish to develop better personal skills in analog representation and to enhance my ability to observe through sketching. Understanding the design process through systematically observing the site by drawing it should provide me with a deeper understanding than possible solely with digital registration, largely because it demands a higher level of engagement. Exploring a future scenario by sketching in the underlying atmosphere via the light and spatial qualities of the site, draws inspiration from Peter Zumthor's coal sketches where both deliberate movements of the hand and the result of material choices contribute quality. The final renderings, which include techniques like ink wash, will describe both technical sections, whereas graphite (drawings?) are anticipated to enhance technical explanation. Naturally, all of this is expected to provide an answer to the underlying question of what can be learnt from an analog process? Will this effort provide a deeper understanding of atmosphere? Will we be able to see what sets an analog process apart from digital recording and explorations? Does the extra observation obtained through hand-drawing bring more meaning to architecture in this digital age. And what is the meaning generated when matter becomes architecture?

Phenomenology

Phenomenology - The idea that the world appear to us as phenomena

The discipline of phenomenology may be defined initially as the study of structures of experience, or consciousness. Literally, phenomenology is the study of "phenomena": appearances of things, or things as they appear in our experience, or the way we experience things, thus the meaning things have in our experience. Phenomenology studies conscious experience as experienced from the subjective or first-person point of view.

METHOD

I see this project made up of three main parts. The first would be to set a theoretical framework by studying theoretical literature related to drawing and analog design processes. The second part would be to observe and design a project using analog techniques. This would involve both recording the site through modes of sketching and designing (drawing and modeling) by hand. The third part of the project would involve summarizing and reflecting on the experience as I describe my design work and put it into relation with the theoretical frameworks I started with. And that should finally allow me to formulate some personal answers as to the question of what is to be gained by accounting for the body-mind relation by including analog technique into my design process.

The starting point and first phase would be to get some more depth to my understanding of phenomenology and begin to envision how the body-mind perspective would deepen and inform a design process. This phase will involve a fair amount of sketching and relating/contrasting my project against theoretical texts by Juhani Pallasmaa and Gaston Bachelard.

After theoretically orienting my project, I see a second step going over to recording the site by analog drawing. Inspired by the work of Pia Linz, a German artist, I would like to construct frames of hard plastic in order to document the whole site as a panoramic view. Linz (2003) describes her work *Gehäusgravur* like this: "I stand or sit under a transparent acrylic glass hood, which is held by a frame at the level of my field of vision. From the inside I look at my surroundings and immediately record what I see around with a brush and paint on the inside of the hood. In contrast to the earlier window pictures, here I pay attention to a preservation of a spatial context that corresponds to the convention of perception." This is much like the traditional use of perspective frames but with the motif drawn directly on the plane. This should force me to contemplate every visible part of the site and its inherent atmospheric qualities like light, rhythms, and space. These findings would then be documented for the remaining project. A panoramic view would be done from the spot where I intend to place the final building. This way of looking at the site would be to force my perception towards everything that has to be depicted, as opposed to photographing, scanning or even downloading height curves, which either lowers the level of engagement or even allows the task to be done remotely without ever laying an eye on the actual sight. Therefore, I do not intend to focus as much on the site itself, since this would mean analog surveying. As much as it could have been an interesting subject, it will have to be left for another thesis. The site will remain anonymous and rather be a cognizant site that we can subjectively visit with the help of sketches and our imagination. Hopefully this will benefit the research questions and allow me to focus more on the subject of analog processes rather than any particular qualities of this particular site. Next, I see the main part of my project to be consumed by hand sketching and, by building smaller models, developing a design through craft. In this

phase I would also like to develop chronological and quantitative guidelines for the number of physical iterations of the sketching phase necessary to produce more intuitive renderings. (Weitschies, 2009)“ [...] with charcoal, it goes quite fast, and it is effective, so we use it quite often [...] All along there are sketches [...] To make something new and evolve, we have to sketch to understand with very thick 6B pencils, but once we know how it will be and only then, we draw with the computer.”

For my final presentation I would like to produce a slightly larger model that can adequately describe the materiality and three-dimensional aspects of the finished project. Considering the models produced by Flores y Prats, which are crafted to express quality of light and space, I would like the final renderings to be in larger format. The inspiration for this comes from Beaux Art and its use of ink wash to convey modes of atmosphere, rendering light, and a sense of moods from inside to outside of the building. I anticipate that the form of my project will lend itself to a juxtaposition of the analog exercises with a more theoretical reflective text. A contrast between praxis and text should provide a good medium to describe my more theoretical conclusions.

THEORY

My main sources for this project are the books *Poetics of Space* by Gaston Bachelard and *The Thinking Hand* by Juhani Pallasmaa.

Poetics of Space offers a close look at spaces, big and small. Bachelard further examines the domestic spaces that hold our dreams and memories. In *The Thinking Hand*, Juhani Pallasmaa argues the need for a stronger and more embodied relationship to architecture or any artistic deed, in contrast to the superficial and over-socialized identity of the current paradigm. He points out a less disconnected endeavor that explicitly recognizes our mind-in-body cognition of the world. This will be complemented with studies from authors like Paolo Belardi, Robin Evans, and others.

DELIMITATIONS

My intention with this project is not to produce conservative architecture or to return to some previous point in history. I mainly seek to uncover qualities related to bodily knowledge that might be unlocked by a more hands on approach. Perhaps in opposition to more rational/efficient methods, I would like to bring my intrinsic knowledge into play. By positioning myself in a less rational position, I hope to avoid what could be defined as artificial thinking; artificial as in defining rational models with parameters, consequently cutting off the mind from its inherent subjectivity or intuition.

The purpose of this thesis and design project is not the determination of what design mode is better than another or to prove a point by creating the most aesthetically pleasing design. The research questions should not encompass a particular understanding of the chosen site or any design result per se. The purpose is rather to deepen my understanding of what constitutes the particularities of analog design and what qualitative dimensions can be tapped into by limiting the design to the realm of analog tools. The design process is the application surface of analog observation to see what can be gained.

READING INSTRUCTIONS

The booklet is divided into chapters chronologically according to how I have worked.

1. In the first chapter, Introduction, I present myself and my work. Here I also present my personal motivations, design process and background, the starting point of this project.
2. In the next chapter, Theoretical Investigations, we get closer to theory of the subject. A phenomenological approach is the basis for my Investigations. In addition, you should be able to follow my arguments for a more embodied approach to architecture.
3. Next comes the chapter, Physical Investigations, where you can see some examples of analog site recordings. This is where I try to explore how space becomes cognizant, through the act of drawing.
4. Then comes the chapter called, Design Proposal, This is where I, through intuitive methods apply an analog design process. Here you will find drawings and models. As well as an explanation to the design method and why it was done.
5. The research ends with the chapter, Discussion.
6. And lastly, there is a Bibliography.

**THEORETICAL
INVESTIGATIONS**

ARCHITECTURE AS A CULTURAL PRACTICE

Architecture as a cultural practice is to elevate "dead" matter or objects and bring them into life, making them the backdrop and context of lived human life and imagination. This is done by observing and arranging physical matter with empathy (relating), all the while on the alert for any potential meaning. Either in and of itself, or in relationship to other physical objects, the practice of this kind of architecture demands observation and reflection. Meaning in relationship to architecture and sensory experiences can be considered from an atmospheric perspective, or in other words as space. It is a kind of intuitive understanding of space that Pallasmaa (2009) denotes to be the phenomenological dimension of architecture (and he urges us to adopt a more meditative work mode where we engage by bodily intuition, such as drawing by hand).

This particular aspect of architecture seems to resemble other cultural activities of contextualizing space, fictional or not. Bachelard (1958) "To mount and descend the words themselves - this is a poet's life. To mount too high or descend too low is allowed in the case of the poets, who bring earth and sky together. Must the Philosopher alone be condemned by his peers always to live on the ground floor?" Could this quote by Bachelard also be considered by architects, is it not true that architects work with contextualized space (not different from text, as in the case of poets and philosophers), are we condemned to the basement? In the above quote Bachelard gives us a critique of an over rationalized philosophical field, where the basic pre-

Pallsamma (2009) Beauty is not detached aesthetic quality; the experience of beauty arises from grasping the unquestionable causalities and interdependence of life. (s.12)

quisites for human understanding of herself in the world is ignored. What if architecture is also considered a cultural practice? This has of course been the case in many instances, it is a classical division within architecture. Some architectural schools are art schools and some are engineering schools. Architecture has always been an art of duality, where the practical consideration (utilitas) is perhaps as important as social and aesthetic considerations. There is no denying this fact of tectonics and practical needs within the field, hard science in other words. But have our needs as embodied beings changed in a digital age where there are obvious needs for strict parameters. Pallsamma (2009) "The human body is a knowing entity. Our entire being in the world is a sensuous and embodied mode of being, and this very sense of being is the ground of existential knowledge." (s.13). Further he argues that not enough consideration is taken to the way humans relate to their surroundings. That current industrialized, materialistic consumer culture exploits our perception and leaves us without a direct connection to the natural world and the matter around us. An argument that the current paradigm deprives us of agency. Not that digital tools in themselves are unbeneficial, but the lack of engagement with the matter and distance to a bodily experience sets us apart from the world as we actually perceive it.

If this loss of agency is the case, how can we engage in conceptualized space more fully and what is space? David Gersten says space is the other part of us. The idea of us is here defined as the reader or writer of this thesis but also us as humans. Space is the pendant to "us", it is what surrounds us, the space we inhabit. It's the "outside" of us that we conceive or create (note the closeness to drawing) through perception/cognition. This attention to the things around us is how we relate to the world, it is meaningful, it is meaning. The act of enculturation of the world does not work as a one way lane, where we project our ideas onto our surroundings or the other way around where the essence of things are presented to us as we conceive them. It is relational, we need to put ourselves in an embodied relationship in order to make sense of things. In the same way we try to treat materials as homogenous when working in digital manufacturing or at least compensate for the irregularities of reality (A block of black wood board). At least for the moment the hand can relate in a meaningful and embodied way to the fluent organic reality of the world and us as a part of it.

**Pallsamma (2009) "The human body is a knowing entity. Our entire being in the world is a sensuous and embodied mode of being, and this very sense of being is the ground of existential knowledge."
(s.13)**

MINIATURES AND REPRESENTATION

At a first glance the idea of miniature seems plain, it is usually understood in architecture as following the dialectics of large - small, one thing relates perfectly to the other or perhaps that they are the same? Drawings or sketches depict that which is larger, a matter of scale. The same goes for models, also a matter of scale, the site model relates to the landscape and that's it.

But is this true? In my research for this project I have in several instances come across the concept of miniature, at first mentioned in Pia Linz's description of her own work, then in depth in the book *Poetics of Space* by Gaston Bachelard. At a closer look, the miniature seems to be something else than the interpreted. It is not mere scale, there seems to be more setting them apart. Bachelard (1958) "Representation is dominated by imagination. ... In line with a philosophy that accepts the imagination as a basic faculty, one could say, in the manner of Schopenhauer "The world is my imagination" The cleverer I am at miniaturizing the world, the better I possess it. But in doing this, it must be understood that values become condensed and enriched in miniature. Platonic dialectics of large and small do not suffice for us to become cognizant of the dynamic virtues of miniature thinking. One must go beyond logic in order to experience what is large in what is small." The idea that representation as in drawing is relational, it's an entry point for enrichment of whatever is studied. Miniature offers more than merely a smaller version of things. Representation or the act of drawing is a conceptualizing act that works in at least two ways. The attention paid in trying to make/create a miniature interlocks the relation between the depicted and the creator of miniatures, meaning appears from thin air. Bachelard (1958) "he entered into a miniature world and right away images began to abound, then grow, then escape. Large issues from small, not through the logical law of dialectics of contraries, but thanks to liberation from all obligations of dimensions, a liberation that is a special characteristic of the activity of the imagination."



Image 1: Test, watercolor on cold pressed paper. Speculations of interior landscapes, characters appearing when imagination attends to the small white stains left out by tape and masking fluid. (Own photo)

TRANSFORMATION

Instances of transformation occur in transitions between different stages as in switching of medium (coal sketches, writing, model making and drawing with a pen) While observing things with sufficient attention, things change, they acquire meaning or purpose. From instantaneous perception to close observation, things "become". Drawing as an example changes the idea of something, while trying to come to grasps with what something looks like. Choosing what to translate to the paper and choices of tools used when portraying something. Not always deliberate but always in relation to the mind in body as stipulated by phenomenology. No matter how rational or efficient something can be done, the core of making something existentially meaningful is relational. Therefore when engaging with the matter around us or the ideas that we drape reality with, these things transition between states of being. It (as in anything) transforms from the stuff beyond us to the space around us. Poetic potential of architecture is the potential of transformation, from "something else " into inhabited space. This transformation is relational for the one that engages or becomes engaged with the cognizant space.

Imagination can be seen as the key to understanding this process of transformation. Evans (1989) says that "The imagination works with eyes open. It alters and is altered by what is seen. The problem is that if we admit this, then the relation between ideas and things turns mutable and inconstant. Such destabilization is bound to affect our understanding of architectural drawing, which occupies the most uncertain, negotiable position of all, along the main thoroughfare between ideas and things". Our imagination reacts to the vague, it has a desire to fill gaps left open. Where there is unclarity the imagination is happy to step in, as in the case of miniatures being gateways to space. There also seems to be a predicament of attention in order for something to be relational and inhabited. It is harder to imagine a vague but unrelated gateway to space.

Transformation can be observed in relation to the design process where things are sketched and prototyped in a flux where the actual design takes place in the in-between stages of things becoming. Where the drawing and observing is intertwined. Where the act of embodied drawing/model building is the prime motor of design, constantly transforming from one stage to another not only progressing chronologically but in many directions instantaneously. The more attention put into the process of designing, the more is observed and the more the object of focus transforms creating trails of thought and traces of meaning.

Evans (1989) says that "The imagination works with eyes open. It alters and is altered by what is seen. The problem is that if we admit this, then the relation between ideas and things turns mutable and inconstant. Such destabilization is bound to affect our understanding of architectural drawing, which occupies the most uncertain, negotiable position of all, along the main thoroughfare between ideas and things"

**PHYSICAL
INVESTIGATIONS**

CHARCOAL STUDIES

The first meeting with the site to be, was annotated through simple charcoal drawings. Charcoal offers an intuitive way of captivating the site and character of space. The way natural coal breaks and leaves unmeant marks on the paper. In its properties it is perfect for a first encounter, it lends itself to a first perception. Zumthor (2006) mentions charcoal as a medium favored for its ambiguity, capturing broad strokes, atmosphere rather than details. But looking at a drawing after it's completed, something else starts to show. There is more in the drawing than what was obvious at the start of the endeavor to capture a certain landscape. When viewing a landscape we instantaneously are affected by it, through our senses we relate emotionally. Zumthor (2006) says "I enter a building, see a room, and in a fraction of a second I have this feeling about it." (p.13). This intuitive understanding of space and atmosphere is what Pallasmaa (2009) argues is the phenomenological aspect of architecture. This process of experiencing a landscape or thing is often emotional but not fully cognizant by the observer. Through drawing and the level of attention needed for the observer to draw forth the contours of the depicted, it forms a relationship between the observer/us and the observed/space, it takes physical manifestation, it takes form. The surrounding becomes space, for space is relational to us.

The interesting thing making it self more clear the longer I draw, is the way that the drawing at first only belongs to the realm of measuring proportions, defining the chosen perspective. From this rational perspective, a question of scale and proportions, something else starts to conjure. In adding the outlines of the landscape, tracing ridges, textures, Depth takes its place in the drawing, the choice of line weight and angle of the piece of coal sets a light hierarchy. Now the image shows objects and characters appearing in the landscape. But the image has only recorded the landscape and added defining borders between things. I have still not really put myself in relation to these things that appear to my sight, I have not applied contrast and importance to the image. The most important choices are not in place. For this last stage in the charcoal studies, imagination takes over, by paying attention and observing the mind can not hold back, it becomes a world in itself. Now looking at the recording of proportions and dividing lines, meaning and hierarchy is applied through the intuitive use of contrasts. This is the drama of the drawing, it expresses the relationship to whatever is observed. It is the meaning of the object, it is no longer only recording of the site. It is the site becoming cognizant.

*Images 2 next page:
Charcoal studies done on site
(own photo)*



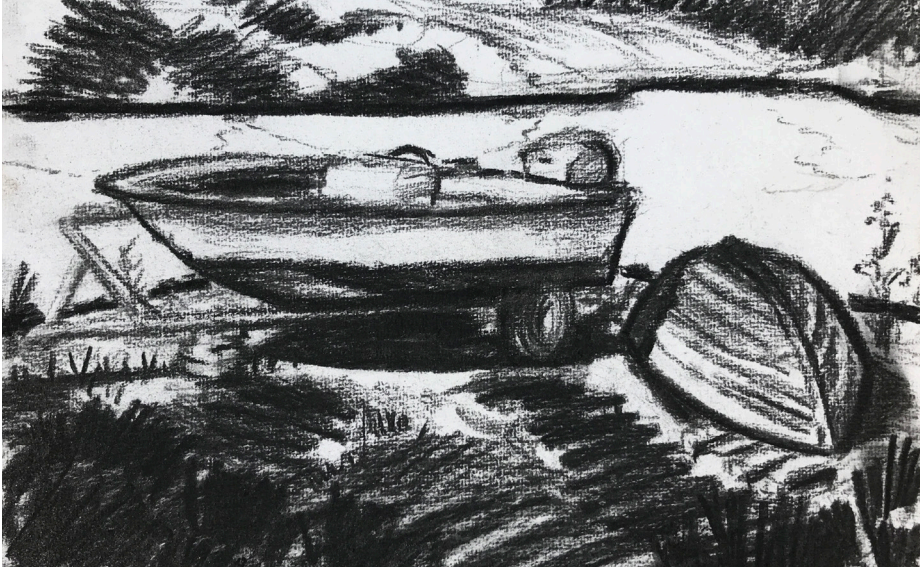

*Images 3, this and next page:
Charcoal studies drawn on site
(own photos)*



THE DRAWING DEVICE

I first had the idea of making a drawing device after reading about the German professor and artist Pia Linz and her work called Gehäusegravur (Case engraving). Where she tries to observe her actual subjective perception from a distance.

My drawing device records the perception of a site in 1:1, as it relates to a specific point in the landscape. It draws inspiration from early attempts to capture perspective like Dürers drawing frame among others. The idea of tracing the outlines of the surroundings could give you the impression that it only relates mathematically to the perceived. But as Linz points out in her own descriptions of her work, in moving away from the site such a recording becomes something else, it becomes the site abstracted. This perception is the "site" compared to the actual location which exists beyond/further than our comprehension, the landscape has become miniaturized. Now the excluded viewer looks at the miniaturized world from the outside. The claimed distance, i.e. the rest of the world, is always inside the object. This device and any drawing is a narrow gate that opens up an entire world.

From the inside I look at my surroundings and immediately record what I see around, here I pay attention to the preservation of the spatial context corresponding to the convention of perception. In the course of the work process, which lasts for several days, I gradually cover myself with drawings, an outward-facing view of the inside.



*Images 4, this and next page:
Drawing device mounted on site
(own photo)*



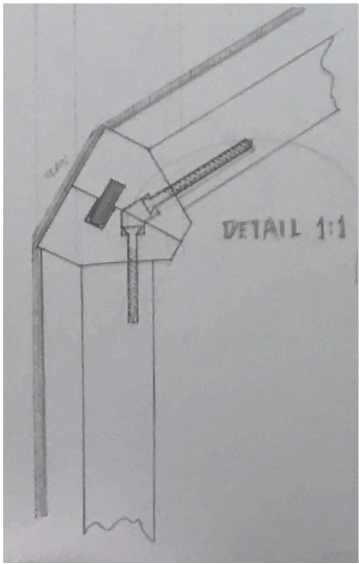
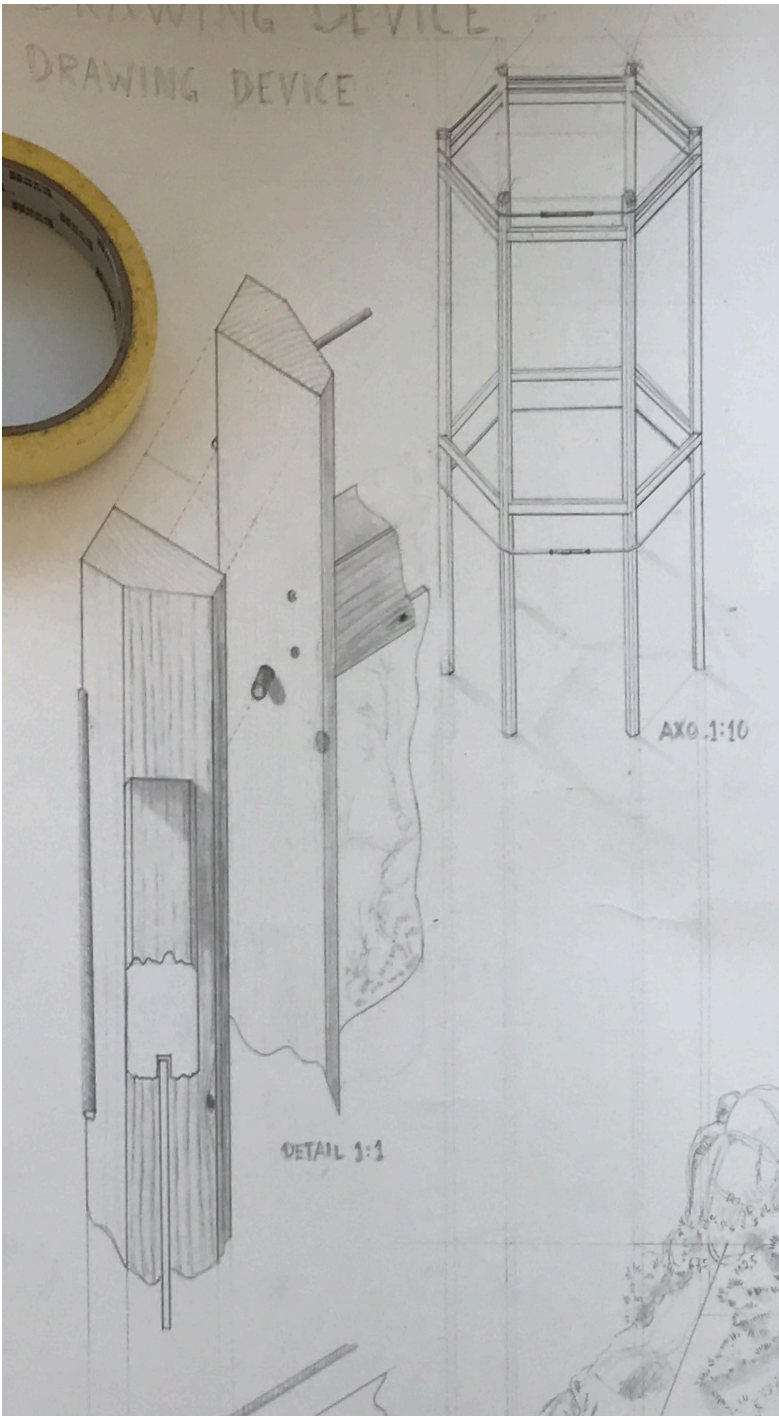
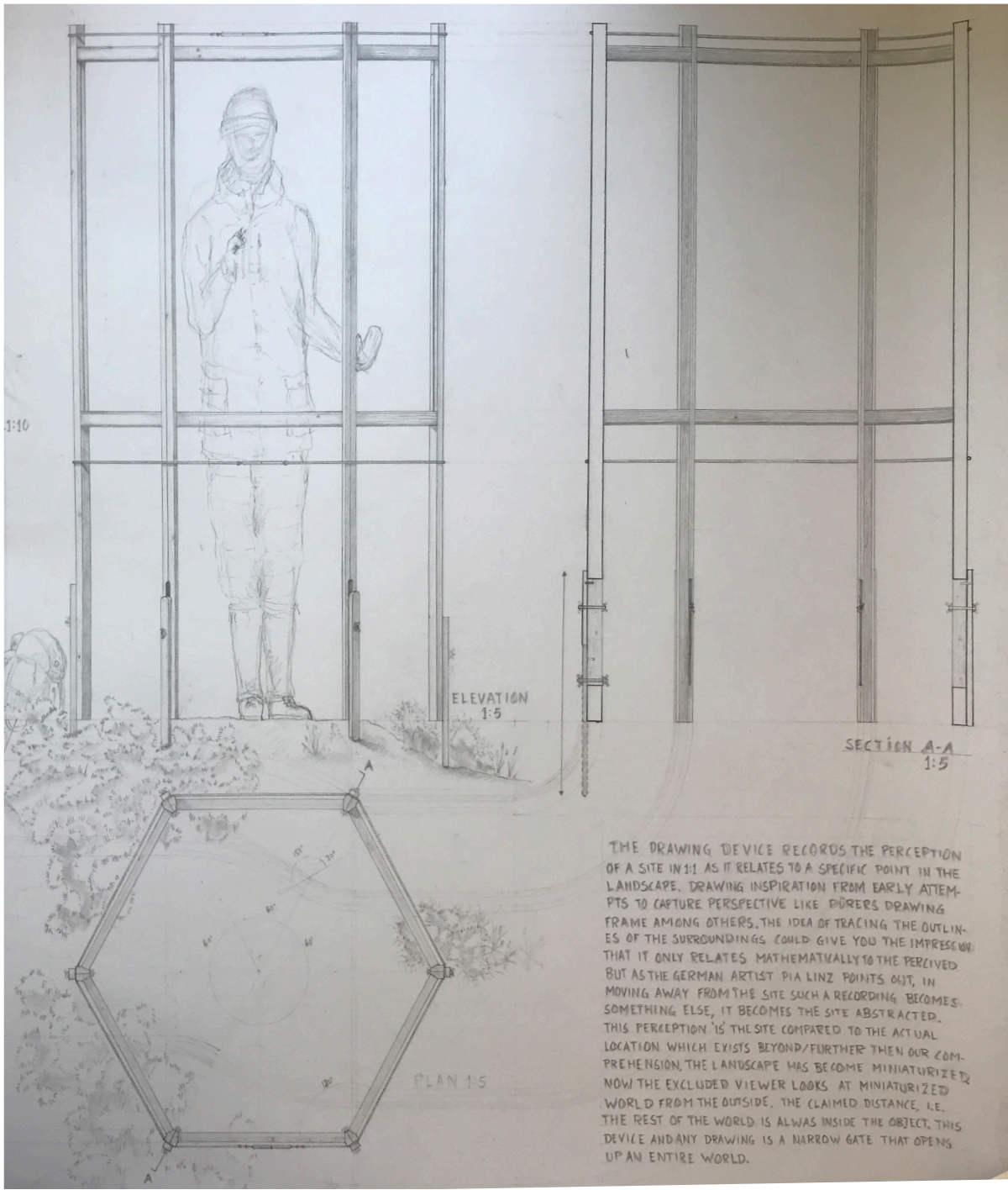

Image 5:
Drawing of the drawing device. Used as a
construction drawing. A world in itself, it also
acts enlarging to imagination.
(own photo)





*Image 6:
Drawing device on site
(own photo)*





*Image 7:
Drawing device on site
(own photo)*



DESIGN PROCESS

DRAWING FORTH MEANING

The Dutch architect Anne Holtrop points out that most things can be inhabited with the help of our imagination. And from this starting point new worlds can emerge as in the example of Bachelard's miniatures. Holtrop (2020) claims that "In my work I start with form or material that often originates outside architecture. In the conviction that things can always be re-examined and reinterpreted, they can also be seen as architecture. In the same way as someone can see a butterfly or a lake in the ink blots of a Rorschach test. I want to look freely - more or less without a plan - at material gestures and found forms and let them perform as architecture. In this way, architecture emerges by imagining the next step that follows the steps already taken."



Image 8: Night Landscape, sculpture by Louise Nevelson, wood painted black. (© 2022 Estate of Louise Nevelson / Artists Rights Society (ARS), New York)

For this stage in my design research i follow 3 steps:

1.

As a part of my design method I plan to collect garbage, bits and pieces found in the vicinity of the site collected and then composed in to nine characters. By intuitively gluing these bits of scrap together, I want to initiate a transformation process that can be examined later through the application of my imagination. I anticipate that this process will highlight my interior process of transforming things becoming things. Much like the black sculptures by Ukrainian/American artist Louise Nevelson made out of scraps and pieces found lying around. I'm consciously trying to avoid steering this process too much or getting caught in aesthetic doubt, as this might hinder the process. Intuition has to be allowed to prevail over rational doubt in order to give me a platform from which to observe my own process. These random bits, pieces of scrap really, in being found unattended, not being anything, now become "something" in the transition between stages and through my act of agency. To highlight this process, I will paint each object black, in order to accentuate the difference between being "nothing" and becoming a "something" that possesses character. At this stage these non-objects would already seem to have attained some meaning, pressing against our mind as Harry Martinsson poems are known to do. Already, the imagination will be trying to inhabit these characters, one might impart a haunted feeling, another might look like a shed, others assume pleasing textures; they are already in relation to us.

2.

The next step is an interior exploration, of which our mind knows little yet. In order to see the interior spaces of these characters I want to help imagination out. By backlighting these objects/characters with an ordinary bicycle lamp, their shadowed outlines are traced onto cold pressed watercolor paper (300 gram). Now the interior space starts to show itself. Making this more vivid, I apply masking fluid and tape on to the interior of the outlines. Then washing the entire paper in five layers of watercolor washes with lamp black (a colder black nuance). Once the tape and fluid is removed nine interior spaces are clearly present. What about them, what goes on in there? The mind attends instinctively to these blank spots, as an inverted Rorschach test. It wants to understand, it wants to lose itself in exploration of this miniature world. Continuing now with a pen, I sketch out whatever interior characteristics that come to mind directly in the blank spaces left out by paint. Then I choose and notate on three of these interior spaces that I find the most compelling to continue working with.

3.

Now that I have chosen three characters with an accompanying sketched interior. This is enough to make physical sketch models. I prepare to let these two-dimensional characters transition over to three-dimensional space by once again sketching them out roughly in charcoal. I build each model to explore texture and materiality. When looking at these models I can now see both the interior space and exterior space simultaneously. They have become spatial and material speculations. One of these models is chosen to become the final design proposal.

1. FIRST STEP

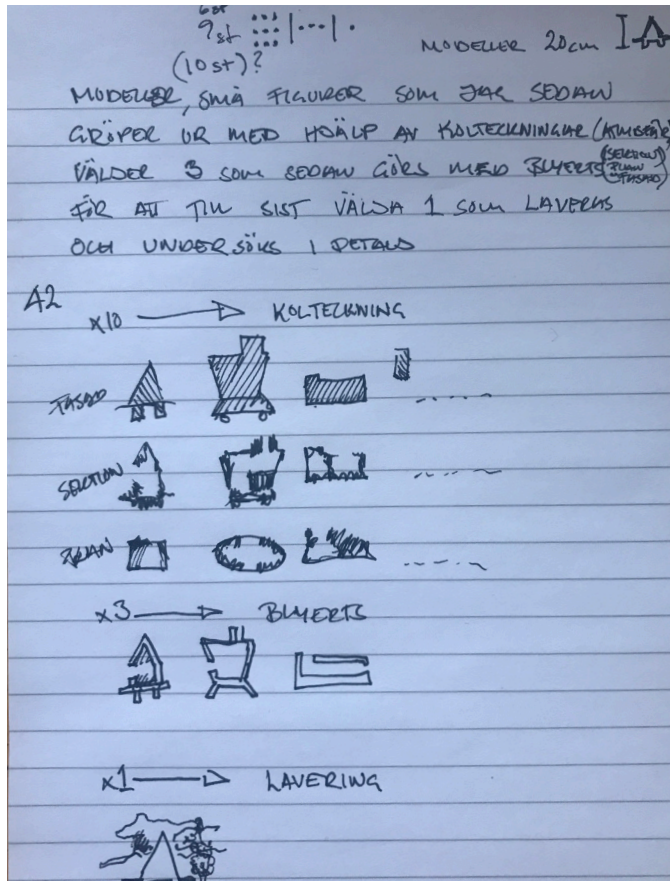

Image 9: Initial sketch of process plan (Own photo)

2. SECOND STEP

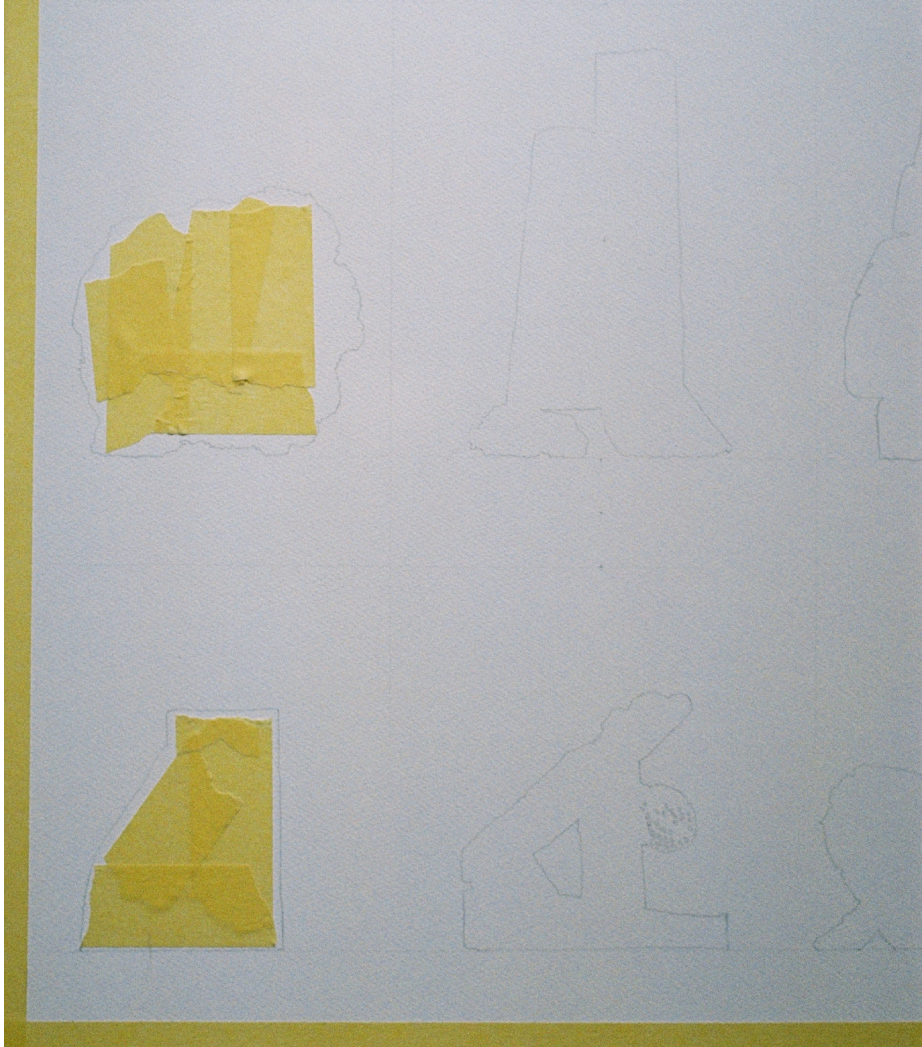

Image 11: Tape and maskin fluid on cold pressed paper. Speculations of interior landscapes, the silhouettes of findings are projected on to paper and traced with pencil (HB). (Own photo)

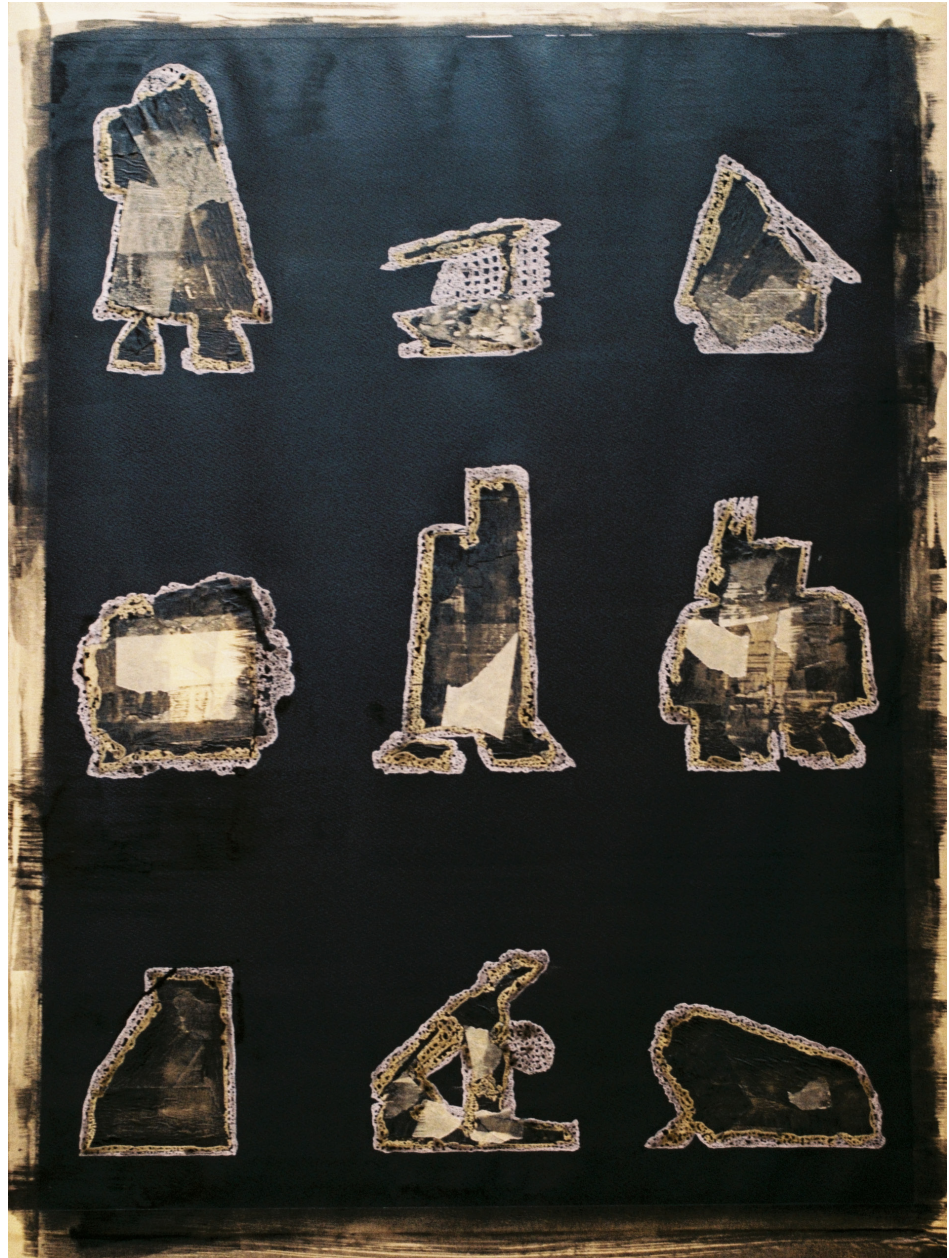

Image 12: Test, watercolor on cold pressed paper. Speculations of interior landscapes, new interior (spaces) appear when surrounding are blacked out (Own photo)

3. THIRD STEP

They become characters

If we accept imagination as a basic faculty of the human mind. It becomes obvious to us that we cannot resist inhabiting space if we let it. The blacked out exteriors focus our attention to the blank but defined interior. Our mind wants to explore this miniature world, it's easy to start speculating about light, furniture and rooms. We can visit these imaginary spaces and if we pay attention also push them further where they reveal more. It is a well of knowledge, for great details can be revealed. This relation to the object and the space that correlates to it is neither solely in the object or in our mind, it's in the connection between them that we are present. It's here we have agency.

With a pen I notate my findings directly on the blank spaces, my speculations are revealed in the instance that the pen starts making marks on the paper. Nine characters open up and reveal some of their interior spaces.

Three of these characters are chosen to be further transformed in model and explored in form and materiality. The chosen three are notated on the poster of characters, then studied in sketch models and coal sketches. Then presented under the coming three headlines, The beehive, The house and The Monolith.

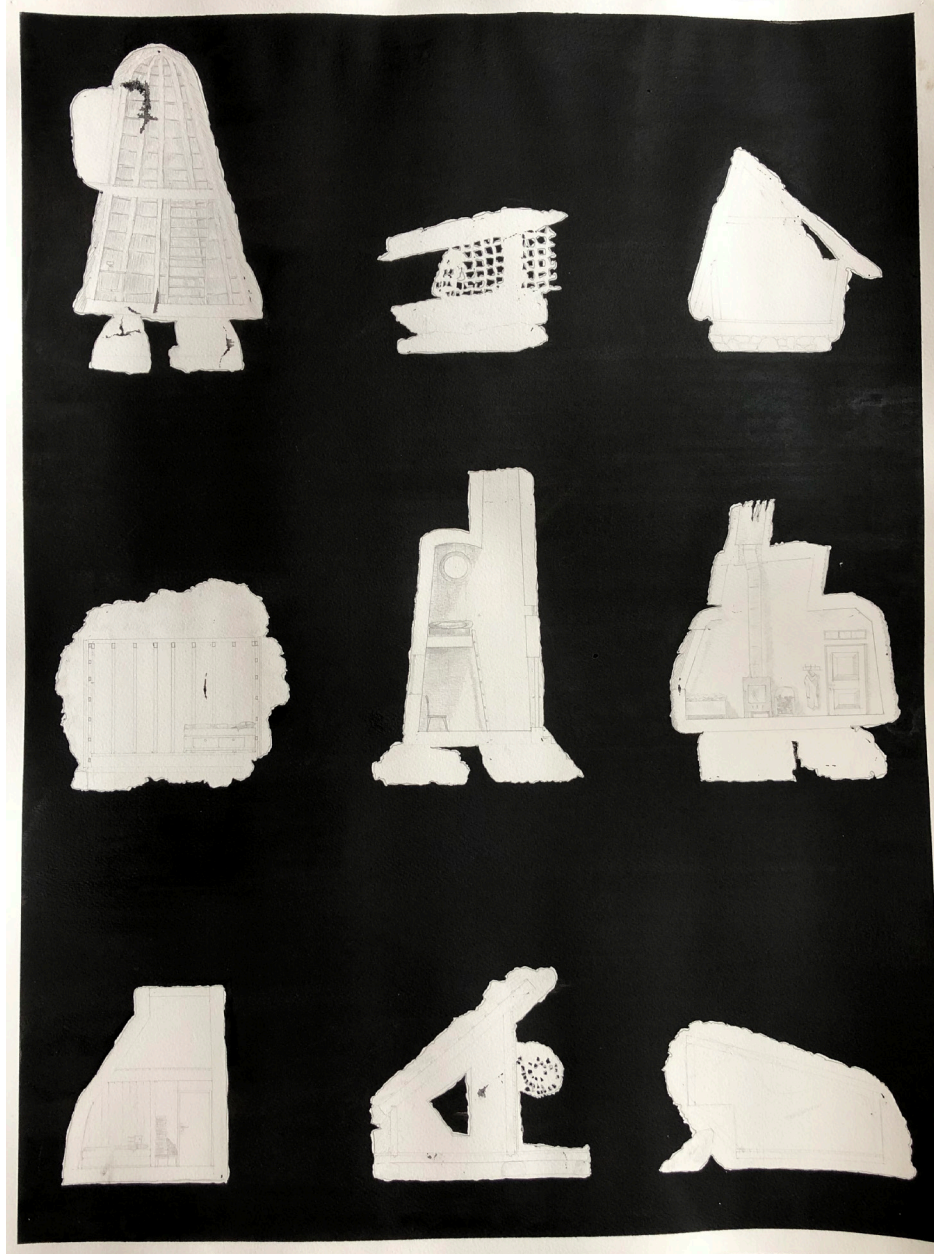
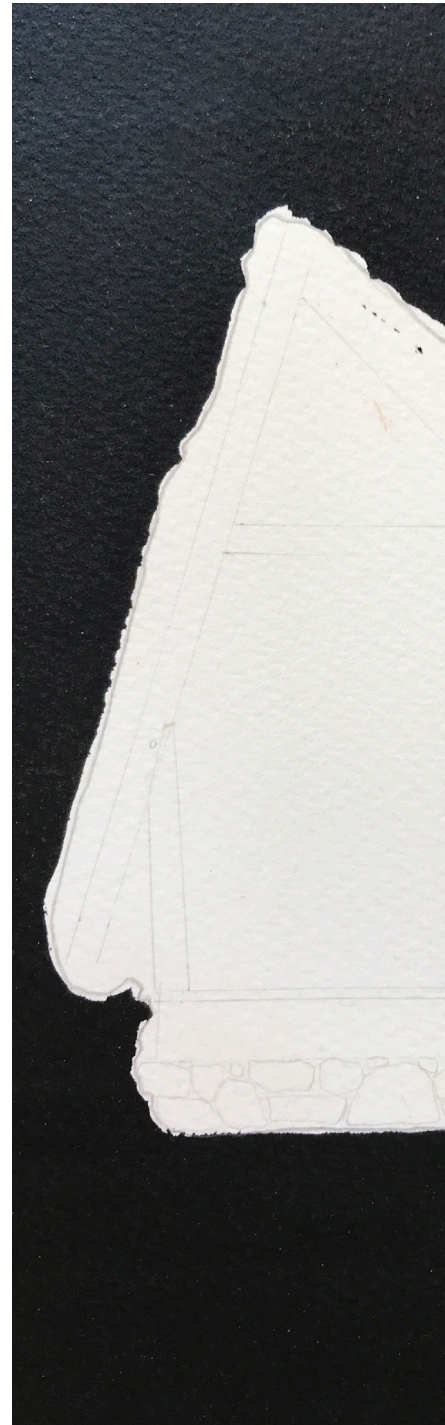

Image 13: Watercolor on cold pressed paper. Speculations of interior landscapes (Own photo)

THREE CHOSEN CHARACTERS

I chose three characters to continue with, they will later be translated in to models:



Images 14: Watercolor on cold pressed paper. Three characters and speculations of interior landscapes and texture (Own photo)

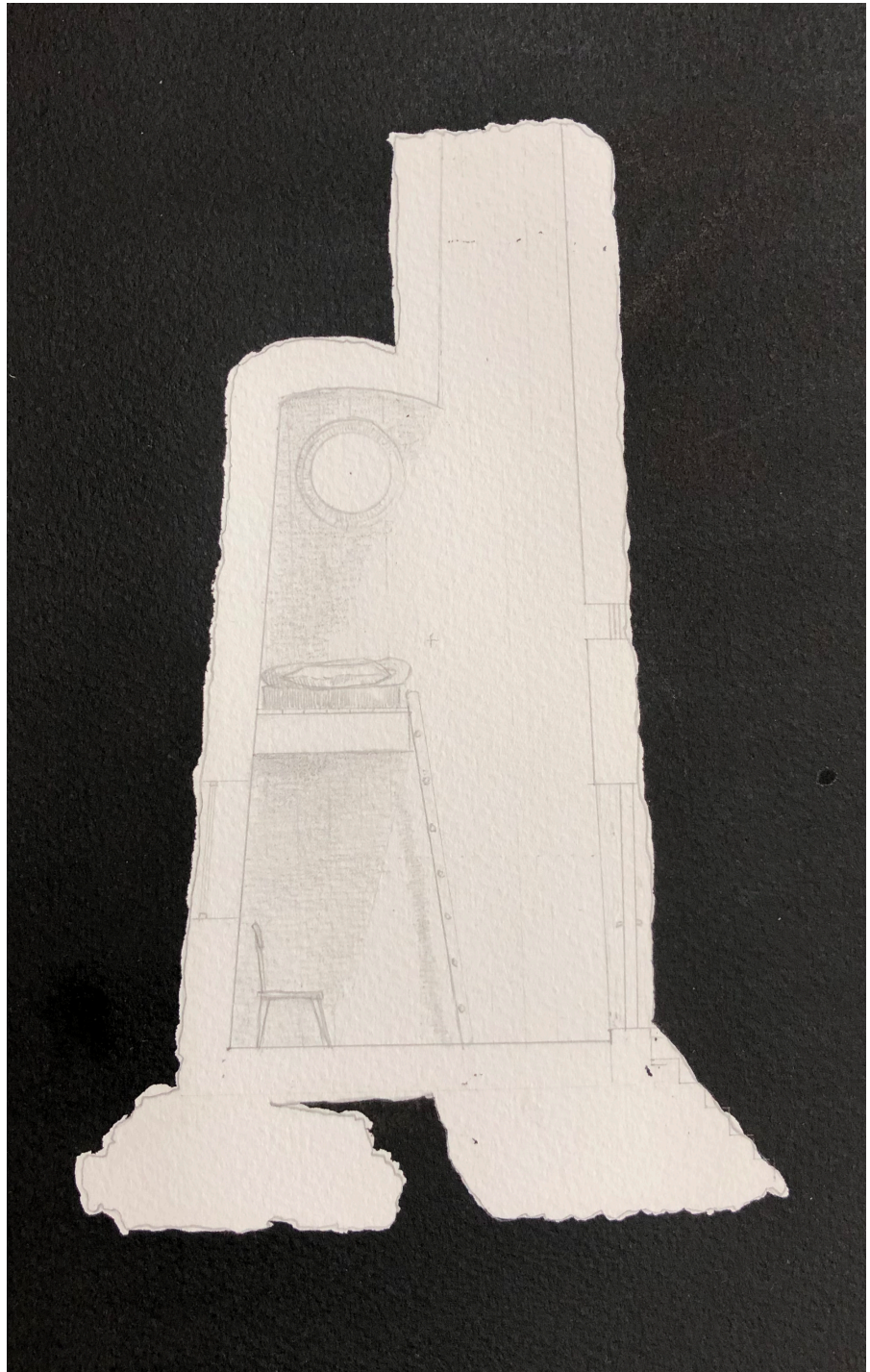
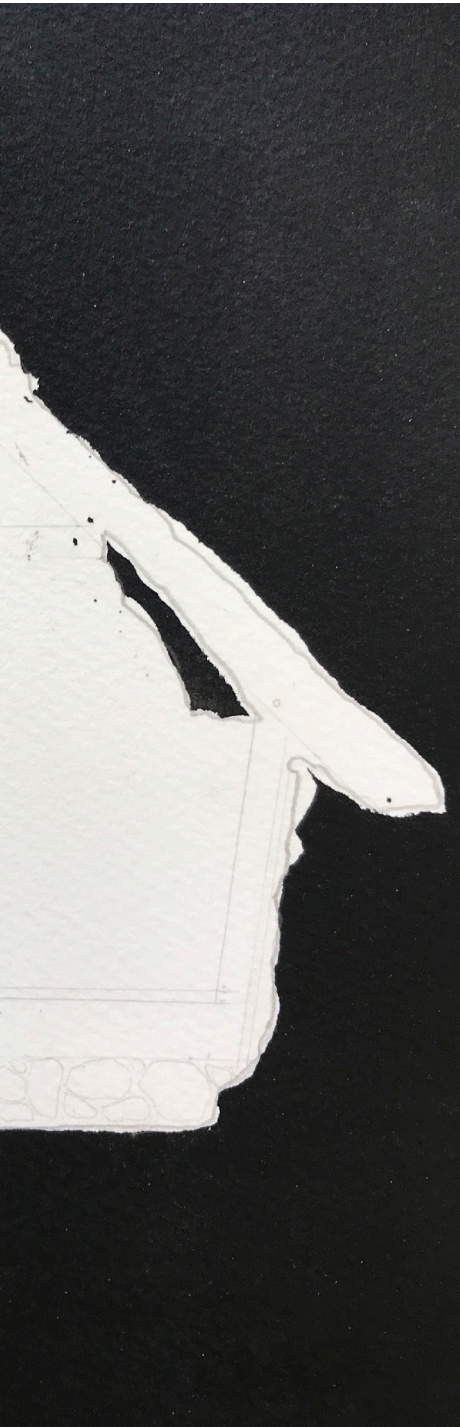

THE BEEHIVE

In the void left by the black watercolor I imagine a primitive hut. In shape it bears resemblance to a haunting figure. Something periscope like sticks out from the side as if it is looking, steering forward towards something. It has a plane and ascetic interior but rich in textures. It's made out of bunches of reeds bound to a simple structure of rafters and beams. From the second floor/loft the world can be seen from a framed view, the eye of the building.

The shape reminds me of reed and straw beehives common through history or vernacular buildings with thatched roofs. My imagination interprets the plastic flotations from an old fishing net as cornerstones. In order to enter this building it needs to be accessed from a later or by steep steps.



Image 15: Sketching out the characters in order to make a model, association and imagination leads this process (Own photo)

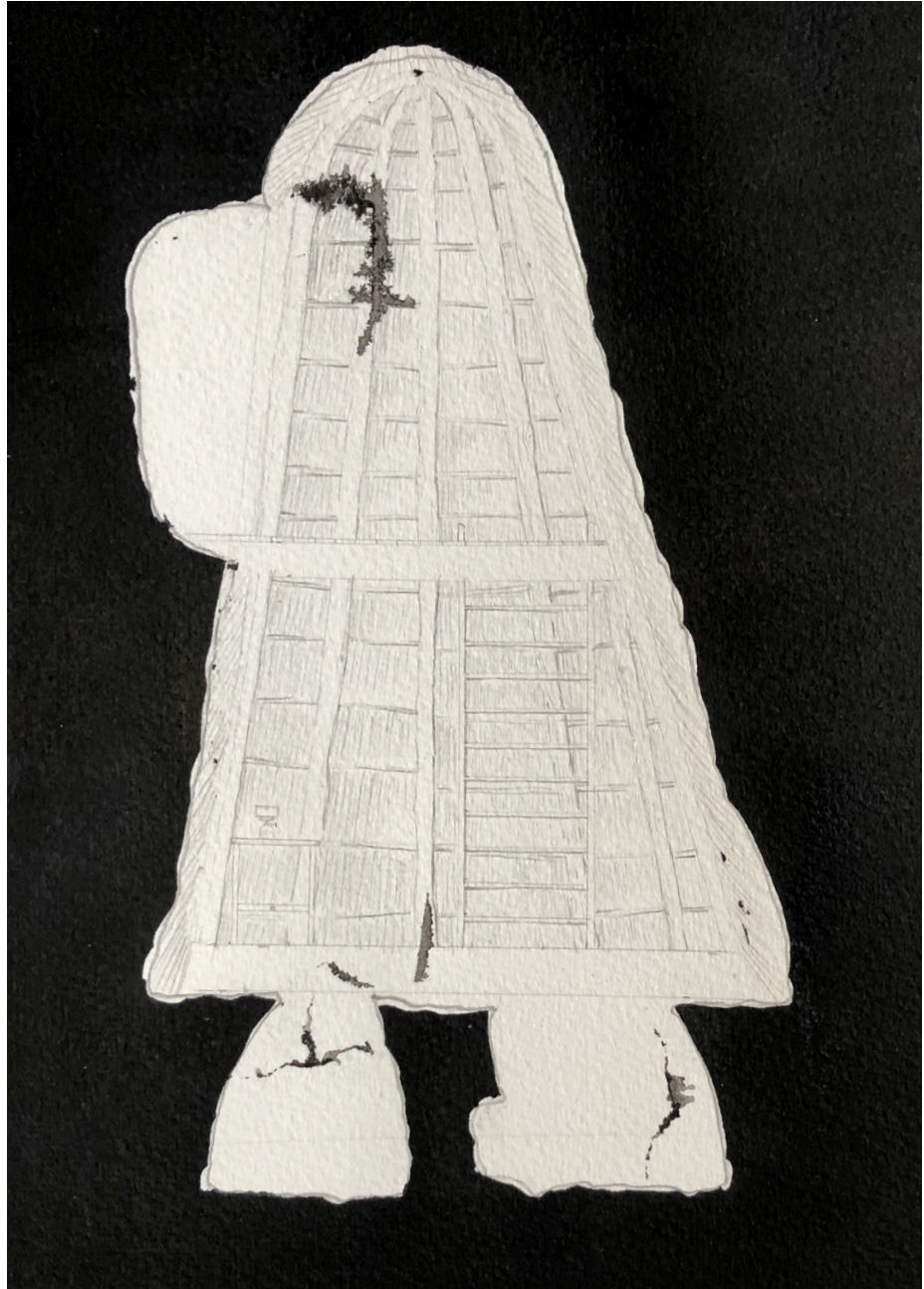

Image 16: Watercolor on cold pressed paper. Speculations of interior landscapes, the bee hive (Own photo)



*Image 17: Sketch model of beehive building
(Photo: own)*



Image 18: Beehives common for the times pre wood frame hives. owned by Olof Persson, Bjeret, Sweden. (Photo: Alf Kahnberg, 1938)

THE HOUSE

This shape was at first hard to access, it carried the shape of a house resting squarely upon its foundation. The shape bored me, and in relation to its slight shift of weight to one side the trusses didn't look pleasing when sketched out in coal. I didn't like it, it felt unsatisfactory to inhabit. But I had chosen it and therefore I looked to explore the possibilities of materiality instead, in hopes of still finding some point in my choice. The blank shape on the paper left out by black color reminded me of a small shed covered with shingles.

I remembered a discussion I had with a Danish carpenter concerning the difference in quality between split and cut/shaved shingles. The gnarly split shingles are both better protected against deterioration due to the longer fibers and also have a rough, nice texture to it. The different wood most commonly used for splitting shingles are pine and spruce. Aspen and oak have also been used for splitting. Oak has the most textured surface of these woods. Oak also has natural occurring tannins protecting it from deterioration. These tannins also make oak prone to discolor (oxidize) in contact with iron. This can be observed around old iron nails in oak boards, it blackens. This process is used in furniture making, called oxidation. It is not coloring the wood or adding pigments but rather the wood in itself changing color.

So therefore "the house" became a test of materiality and character, rather than space. A small house clad in oxidized oak shingles. Nesting among the heather as an old shed.

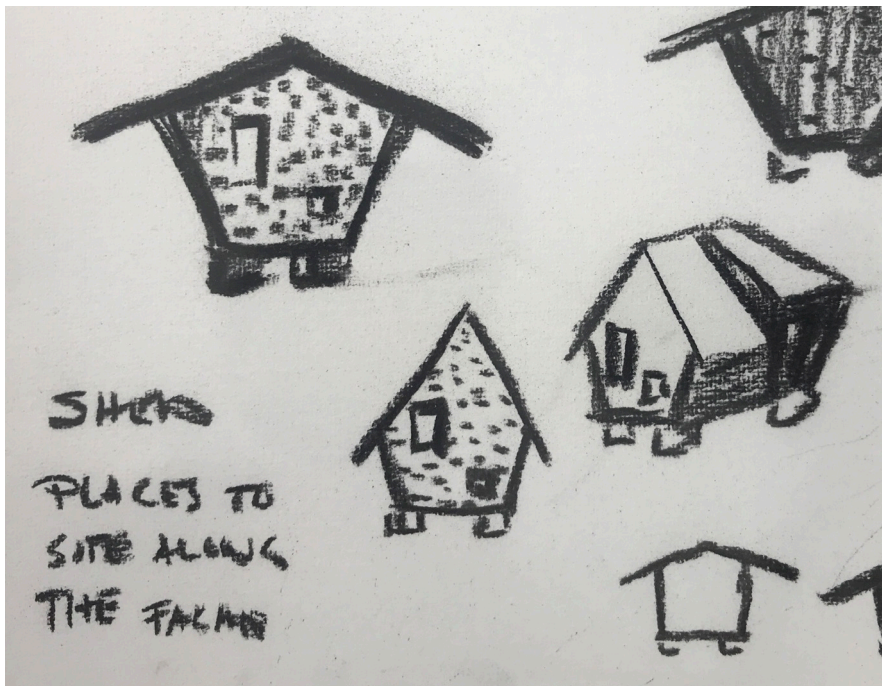

*Image 19: Early sketches of the house (predating the name: the house) in order to test the shape.
(Own photo)*



Image 20: Watercolor on cold pressed paper. Speculations of interior landscapes, the house (Own photo)

RECEPIE FOR EBONIZING OAK

1. Portion the steel wool to achieve the desired tone while the vinegar heats to a boil. For this recipe, I normally use one half of an unrolled bundle of steel wool. If you want to achieve a different tone, the basic rule of thumb is to use less steel wool to get a lighter color and more steel wool to get a darker color.
2. Wash the steel wool with soap and water. This will remove any oils from the factory and help the vinegar to better penetrate the steel wool. Be sure to pat dry the steel wool with a paper towel.
3. Tear the steel wool into small pieces and place them in the empty mason jar.
4. While outdoors, pour the boiling vinegar over the steel wool until the mason jar is nearly full. Keep the lid off the mason jar while the vinegar reacts with the steel wool. This chemical reaction will produce hydrogen which needs to escape in an open-air space. Let the solution sit for one week for a dark tone.
5. Remove the steel wool from the cooled vinegar using protective gloves. Be sure to squeeze out any residual vinegar that is soaked up by the steel wool.
6. Brush on the oxidation solution to bare, unfinished wood with a disposable foam brush or rag. The oxidation process will begin immediately and it will be visually apparent in a matter of seconds. However, the full effect of the oxidation process will continue over several minutes, and it may take up to 30 minutes for the final color to appear.



*Image 21: Ebonizing oak by oxidation
(Photo: Own)*

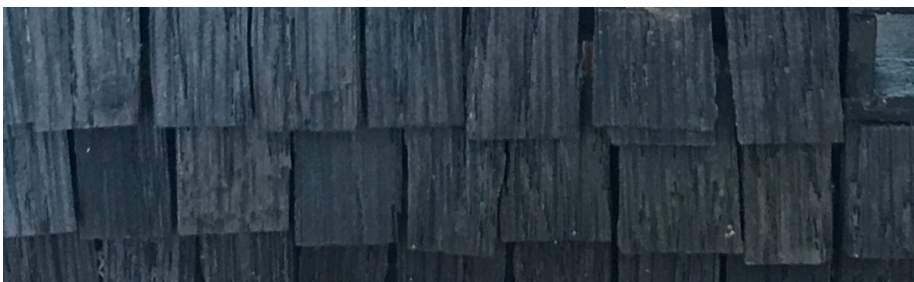

*Image22: Oak shingles made by splitting wood, more durable than sawn. It also leaves thinner shingles with more structure
(Own photo)*



*Image 23: Sketch model of the house, speculations of texture and space
(Own photo)*

THE MONOLITH

This angular and clear shape lends itself to a concrete or timber structure. It's sculptural and rises from the vegetation as an alien object. It breaks loose as a singular object not relating to the organic landscape. The shape of the monolith stands up against the strong wind, not bending as the trees and bushes around it. When tracing the shadow of this character its surface seems smoother than some of the other characters. Is this a wooden cladding of simple boards? Is it painted black or charred by burning its surface? A vivid memory that came to mind was an image from my childhood, a wooden two story building that had been plastered but now this was starting to come off. The building had been abandoned, waiting on a decision from the municipality on its demolition. Parts of its wooden walls revealed and covered with thousands of wooden mortises nailed to its surface. This for some reason resonates when I look at the defined white space.

At first it seems clear to me that this monolith is black. In order to signify its standing apart from the surroundings. And it is plastered with a tinted coarse lime plaster. This treatment covers everything except for the windows, even the door and corner stones, everything is plastered.

This is the proposal that resonates the strongest with me and I therefore pick this one moving forward in my design towards a final design proposal.

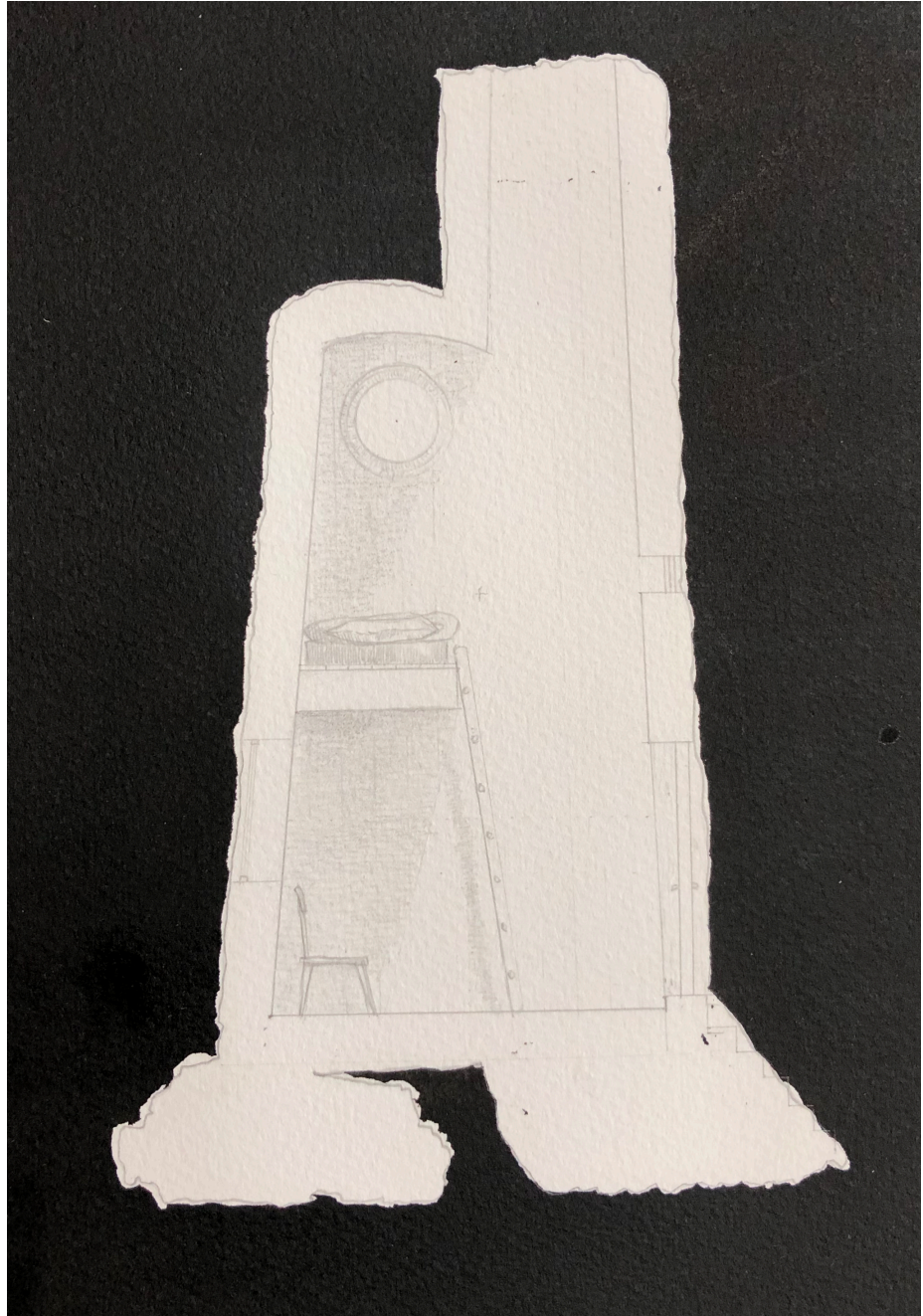
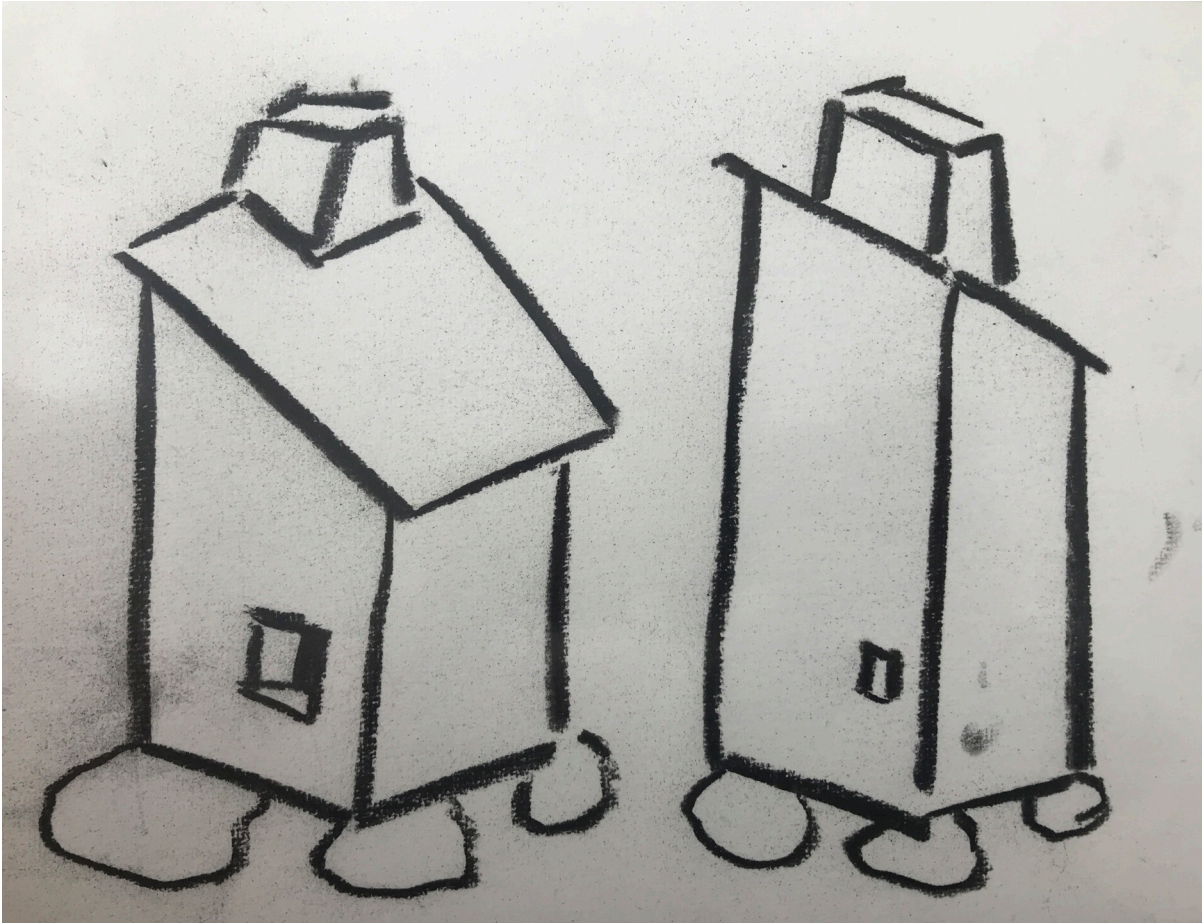

Image 24: Watercolor on cold pressed paper. Speculations of interior landscapes, the monolith (Own photo)



Images this page 25: Charcoal sketches of monolith building (Photo: own)



*Image 26: Image of Anne Holtrop and Krijn Koning. Park Vliegbasis Soesterberg, Netherlands. Pigmented plaster covering every part of the structure
(Photo: Pieter Cruq)*

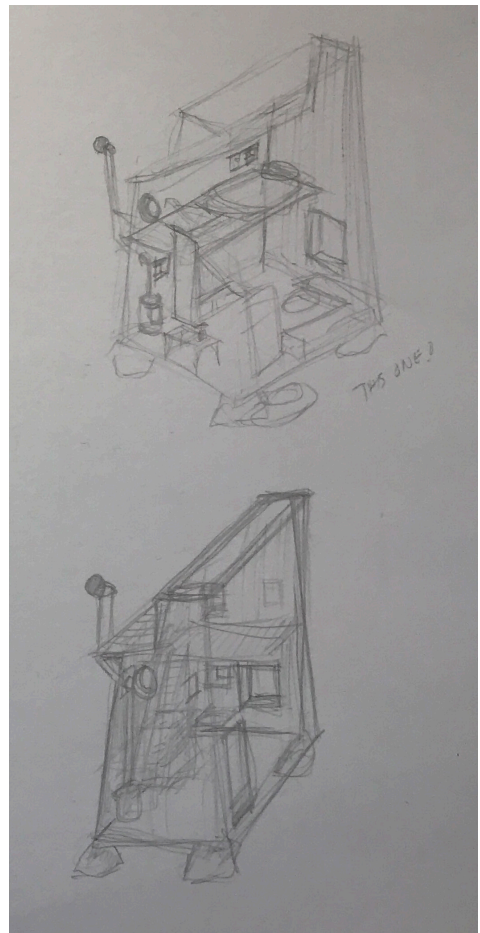
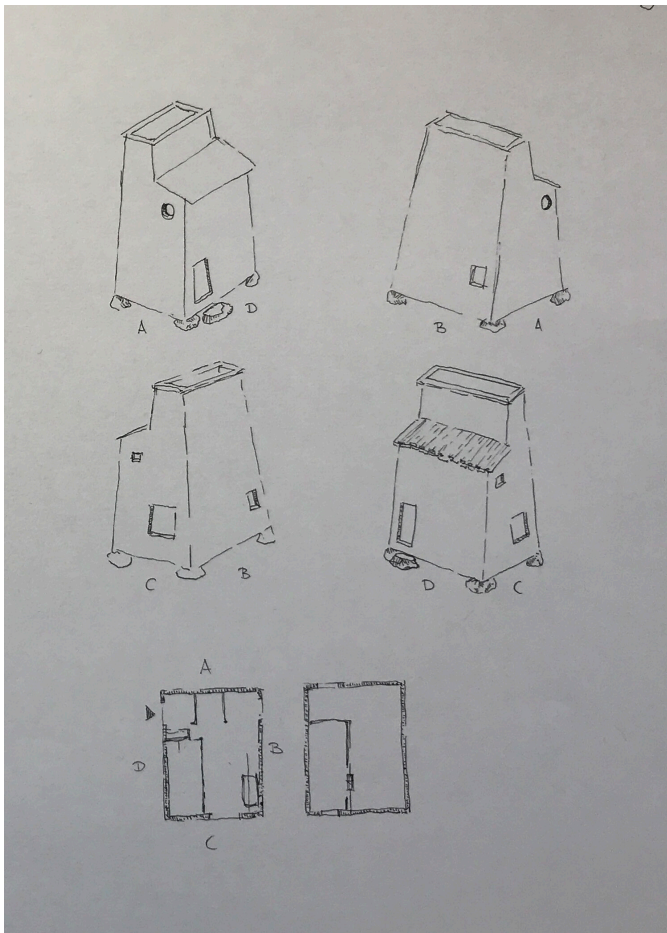
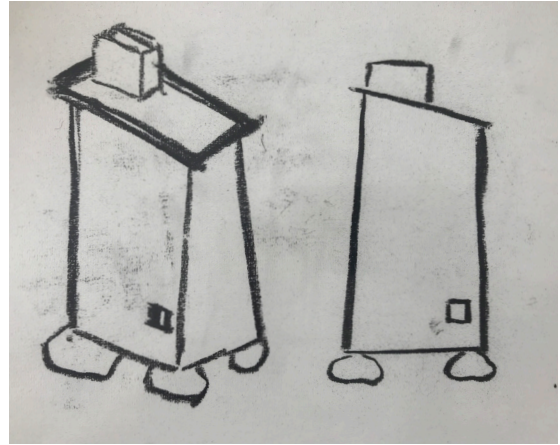
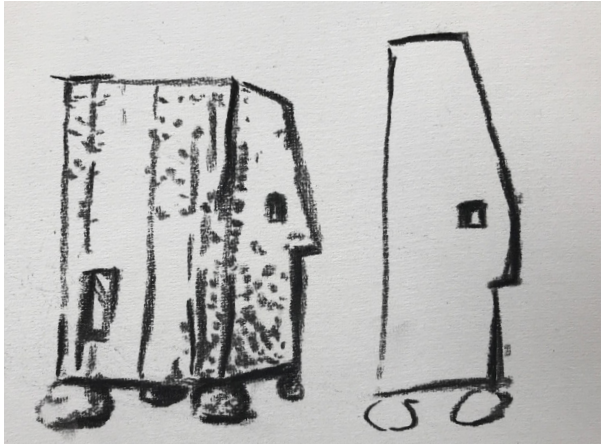

Image 27: Sketches done to try to figure out how to build the monolith (Own photo)



*Image 28: Sketch model of the monolith
explores texture, space and color
(Own photo)*

A FINAL DESIGN PROPOSAL

In choosing to continue with the proposal of monolith it also becomes the final design. For this next and final step I once again change medium facilitating the design exploration. In this final stage I use a sharpened pen ranging from hard to slightly softer graphite (9H-HB) and apply layers of ink wash in order to render this proposal with greater detail than done before. The scale is therefore also more precise. In changing medium new things come to play, where there was no detail from the beginning, now pure necessity has added them, windows, space sufficient for a bed and constructional alteration in order to support the structure, etc.

This design proposal is primarily the application surface of observing an analog process and how something becomes cognizant in relationship to architecture. But it is also an analog design process resulting in a design proposal. Therefore there is still reason to look at the suggestion and define certain details or at least suggest methods of construction. I have done so in researching the actual materiality of the structure and highlighting the lime mortar plaster. Especially when this method of plastering is done to heighten the perception and pinpoint the matter of a structure "becoming" Just as the earliest models made out of junk found around the site were painted black. The black melts the different parts of the building together enhancing the character, just as in the examples of Louise Nevelson's art pieces, becoming something that was scrap from the start.

It is a building or shelter, occupying a 4 x 5,5 m footprint, perched onto a cliff granting shelter for 1-2 people during a couple of days. It is a hermitage and refuge for observing the world as it comes to us through our perception. It is inhabited space because in our mind we have already visited it.



*Image 29: Final proposal, model wood and plaster, This is the final iteration of the design proposal
(Own photo)*

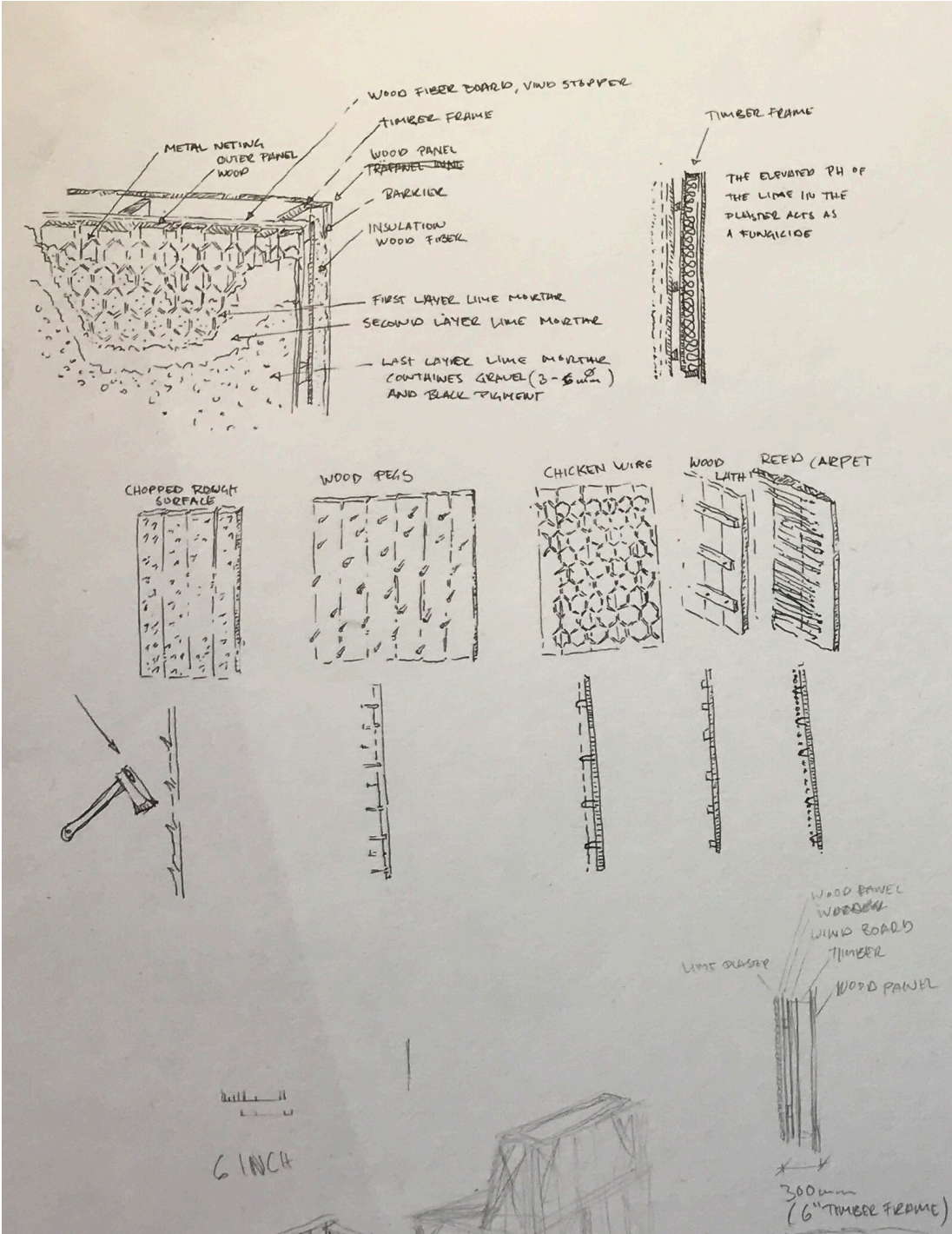

Image 30: Constructional notations, Ways to work with lime plaster on wooden facades. The chopped surface is deemed most suitable because of the difference in board sizes used for the panel, it already has some structure which is good when plastering. Now there is only need to make some additional cuts in the surface for better vertical grip, this is done with an axe. (Own photo)

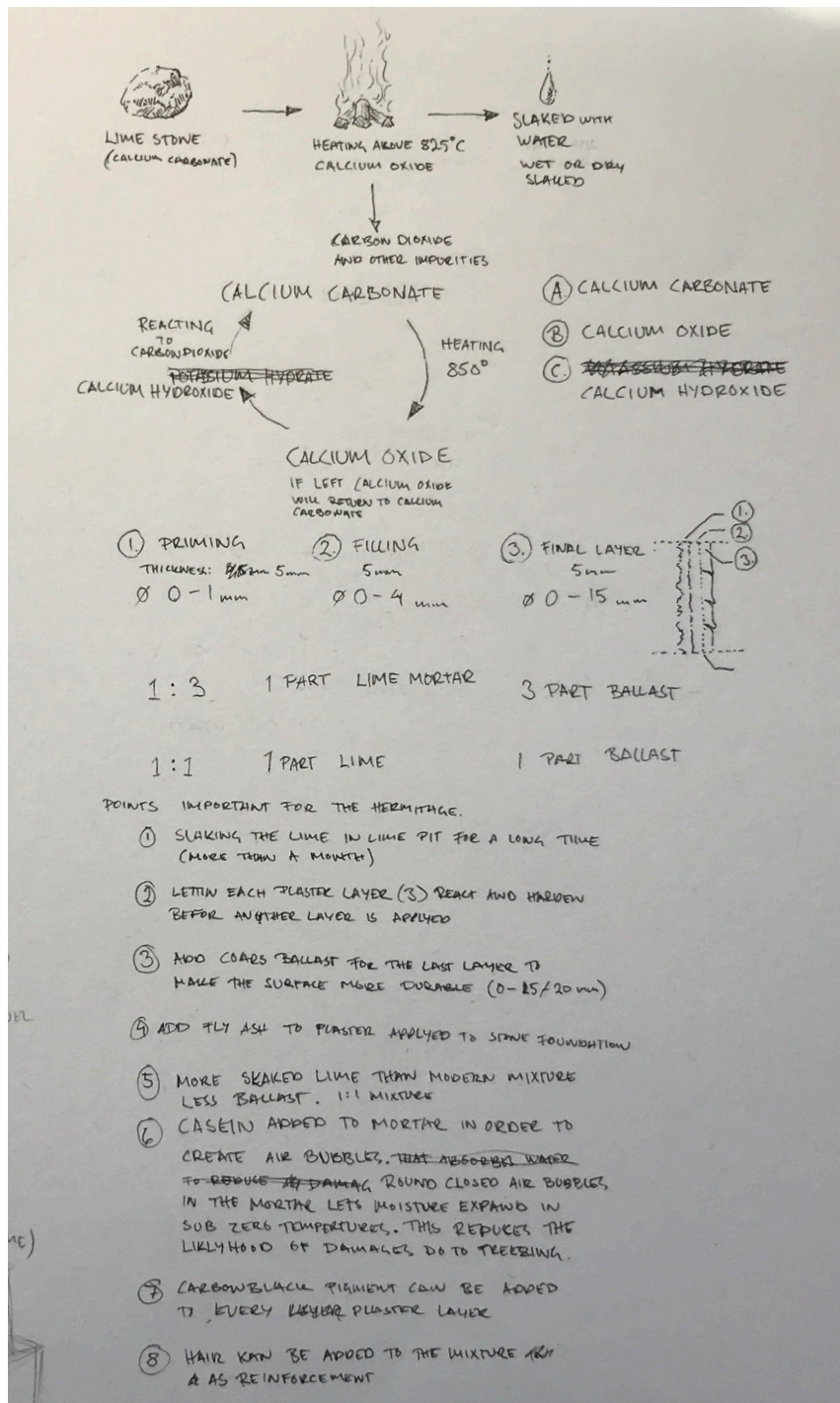

Image 31: Notations on best practice for this project when it comes to choice of plaster and its mixture. There will be a difference in proportions when plastering wood or stone. Cornerstones need added fly ash to the mixture to make it carbonize (own photo)



*Image 1: Final proposal, here the project is placed back into the charcoal drawings but now at larger format, Printmaking paper 300g, 1000x700 mm.
(Own photo)*



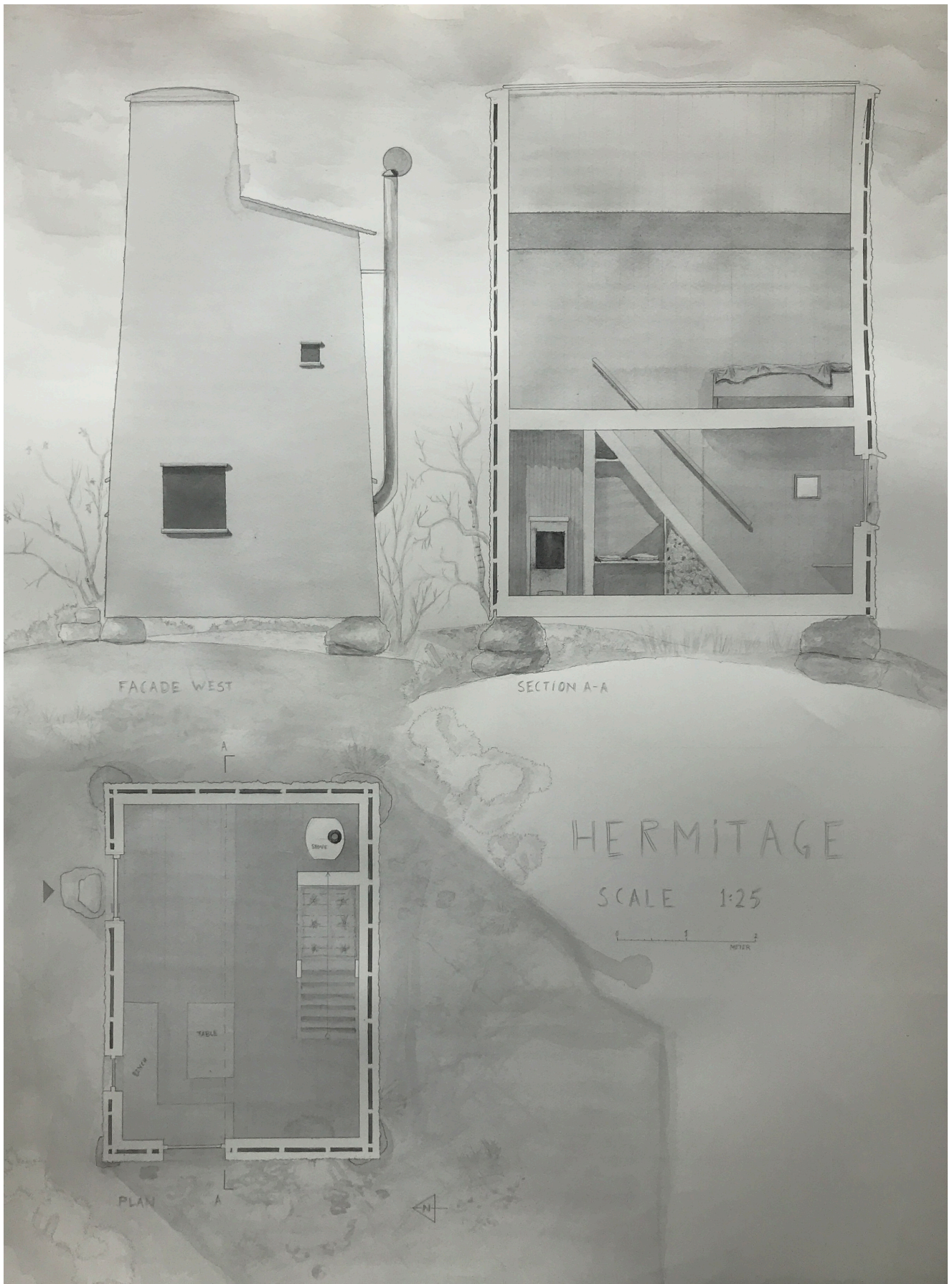

Image 1: Final proposal, facade, plan and section, watercolor paper satin 300g. (Own photo)

**Long did I build you, oh house!
With each memory I carried stones from the bank
to your topmost wall.
And I saw your roof mellowed by time.
Changing by the sea.
Dancing against a background of clouds.
With which it mingled its smoke .**

- Louis Guillaume, Maison de vent

WHAT ARE MY FINDINGS

In following my proposed path of explorations, some personal thoughts and revelations really stand out for me. By realizing the idea of "Architecture as Poetic Undertaking" it becomes possible and meaningful to take an embodied approach seriously. It is possible that this dimension of analog technique could be judged to be either less relevant or more outdated than other topics presently considered more acute, such as sustainability. Sustainability is commonly seen as belonging in the domain of hard science when considering life cycle analyses or when measuring energy efficiency. But the fundamental change that is being demanded of us is also cultural; it has very much to do with how we perceive the world around us. Are we a part of it? Or is it something beyond us, out there? I believe that analog design acts strengthening our embodied relationship to the reality that surrounds us on all sides. This could be called a thing of fantastic potential, this relating to the matter around us, a means to seek salvation in the way we erect space. That relational and perceived space is our only true "home." A rock is a rock, that is, until someone perceives it as a cornerstone. Therefore, embodied design does not necessarily stand in opposition to any other goals that we might need to strive towards. Except for the fact that it often demands more time and space. But this time and space is not at all wasted, but extremely meaningful at its core. Conversely, more detached approaches do much less to support the creation of meaningful bonding relations to the world around us. For the time being we are stuck in our embodied perception of the world and there seems to be no way around this fact. But precisely because of this fact, we actually can and need to relate to the world.

Architecture is an art of duality; it has, as said earlier, a real need to apply the principles of tectonics and utility. But we are also obliged to do architecture as part of contextualizing the physical reality that surrounds us, as well as the spaces we erect. We are, at the same time, fully engaged in making the backdrop for our lives or giving concrete form to our thoughts. Not so much as aesthetic acts of decoration but more as a means of fulfill other deeper needs. Through the faculties of our imagination we "see" what can/could be and, in the same way, that which could be, actually becomes. The world comes to us based on embodied thoughts no matter what tools we can access. Our choice is either be a part of it, or not. In working with this thesis, I have found that the task of spinning together all the traces left in the wake of observation, the weaving of those disparate threads of thought and reflection into a "whole cloth" of meaning demanded a lot. Luckily, it is also a rewarding task, if the necessary time is allotted to it.

Analogue drawing distinguishes itself from other modes of recording or design by the demands it makes on the necessary level of attachment and attention, thereby, affecting the participant at a deeper level. It locks the participant firmly to whatever is drawn. The question remains if this is directly translated to an observer of a drawing. Could it be that analogue process only touches the one who has actually carried out a task like this? I actually doubt that, since things are never in themselves totally separated from each other. As this project points out, in order for things to become they first need to be relational. This should be no less true, even in this case. The observer of any contextualized thing will eventually become aware of the fact that this thing, whatever it is, exists in relation, just as we see that things bear the traces of the observers thought or of its present state of being. We feel reminded of the context of a thing when we notice traces of tools on a wooden board or when we see the chipped off corners of an older concrete structure. Imagination will attend to any spots of vagueness, and it simply will not do as good of a job filling in similar details on a "nothingness."

Another reflection that comes to mind as a result of this project is that there are probably some serious limitations on the type of results/goals that can be reached with techniques that build on an artificial rationality. It is plausible that many aspects of the human predicament can only be treated via a substantial engagement with analogue processes in real life. This is the poetic potential of architecture. No matter how far we expand our technological horizons, we still need to create meaning in the physical space we inhabit.

Humans really are heir to every possibility within themselves, and it is only up to us to admit it and accept it. You see, you can buy the whole world and you are empty, but when you create the whole world, you are full.

**- Nelsson. L,1989, interview by Arnold Glimcher
"Louise Nelsson Remembered"
NY: The Pace Gallery**

BIBLIOGRAPHY

BIBLIOGRAPHY

LITERATURE

Pallasmaa, Juhani. 2009. "The Thinking Hand."

Pallasmaa, Juhani. 2012. "The Eyes of the Skin"

Merleau-Ponty, Maurice. 1945 "Phenomenology of Perception"

Allen, Stan. 2020. "Thinking in Models"

Zumthor, Peter. 2006 "Atmospheres"

Weitschies, Rainer. interview on the 11/07/2009 in Haldenstein

Bachelard, Gaston. 1958. "The Poetics of Space"

Ruskin, John. 1857. "Elements of Drawing"

Atwood, A. (2014). Rendering Air: On Representation of Particles in the Sky. Log, 31, 47-51.

Evans, Robin. 1986. "Translations from Drawings to Buildings and Other Essays"

TEXT AND LECTURES FROM WEBSITES

Rizzi, R, models and lectures. The Rebellion of the Invisible. Faculty of Architecture of TUDelft on the 11th of May 2016. <https://vimeo.com/190553847>

Stanford Encyclopedia of Philosophy. (2013) Phenomenology.
Retrieved from <http://.plato.stanford.edu/entries/phenomenology/>

Nevelson. L, Louise Nevelson Remembered, interview by Arnold Glimcher
NY: The Pace Gallery, 1989.
<https://www.jmartmanagement.com/post/louise-nevelson-the-artist-and-the-legend>

IMAGES

Image 8: Estate of Louise Nevelson / Artists Rights Society (ARS), New York (2022). Night Landscape, sculpture by Louise Nevelson, wood painted black, The Museum of Contemporary Art, Los Angeles. [Online Image]
Retrieved from: <https://www.moca.org/collection/work/night-landscape>

Image 18: Khanberg, K (1938). Beehives common for the times pre wood frame hives. owned by Olof Persson, Bjeret, Sweden. [Online Image]
Retrieved from: <https://www.vittsjobjarnum.nu/artiklar/historia/verum/8943-bikupor-i-verum-1938-av-den-for-trakten-vanliga-typen.html>

Image 26: Crucq, P (20xx) Image of Vliegbasis Soesterberg, Netherlands, Anne Holtrop and Krijn Koning. [Online Image]
Retrieved from: <https://www.embeddedart.nl/model-former-soesterberg-airbase.html>