



# vernacular: reinterpreted

*Low-tech dwelling in Johanneberg*

Elin Lidén & Martin Lindholm  
Master thesis spring 2021

Chalmers School of Architecture  
Department of Architecture and Civil Engineering

Supervisor: Walter Unterrainer  
Examiner: Krystyna Pietrzyk

# vernacular: reinterpreted

*Low-tech dwelling in Johanneberg*



**CHALMERS**  
UNIVERSITY OF TECHNOLOGY

thank you!

Walter Unterrainer  
Hanna Morichetto  
Krystyna Pietrzyk  
Tabita Nilsson  
Peter Lindblom  
Charlotta Berggren  
Maria Tjäder  
Staffan Linné

friends & family

© Elin Lidén & Martin Lindholm  
Master thesis spring 2021

Chalmers School of Architecture  
Department of Architecture and Civil Engineering  
Architecture and Planning Beyond Sustainability

Building Design for Sustainability  
Supervisor: Walter Unterrainer  
Examiner: Krystyna Pietrzyk

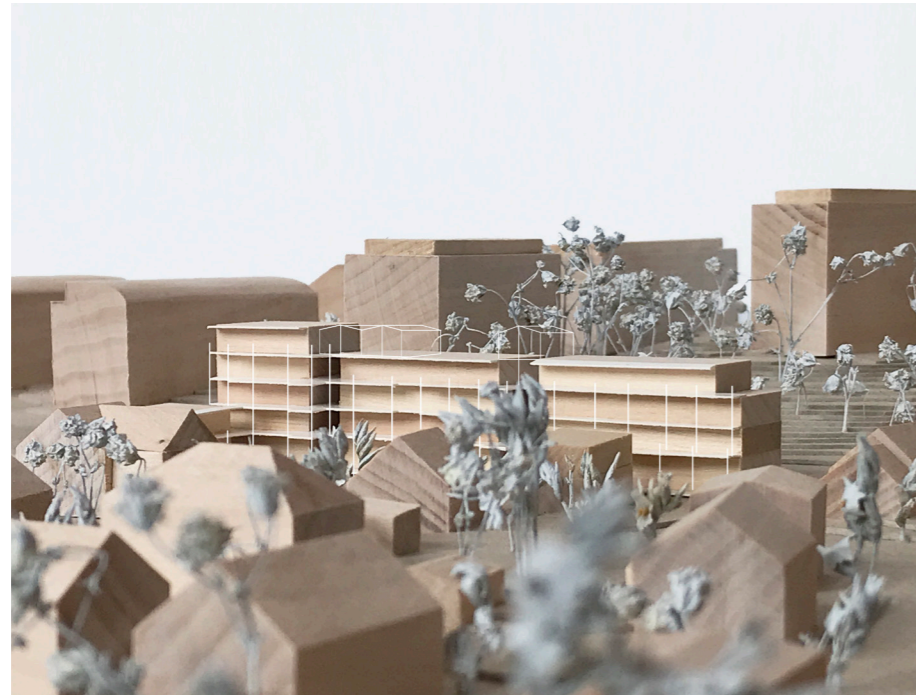

## abstract

During the 20th century, dwelling architecture in Sweden has changed from being a product of a local building tradition, local materials and a local climate, to become a complex machinery of high-tech, high processed components, standardized for a globalized world.

In this transition, the professions of architects and engineers have developed and become increasingly divided, resulting in a separation between building systems, building materials and the architectural space. At the same time, the indoors has become the dominating human environment, greatly affecting our health and our relation to the outdoors.

This thesis aims to take critical inspiration from and reinterpret vernacular principles in a low-tech design proposal for a multi-family dwelling in the area of Johanneberg in Gothenburg. The aim is a design where the composition of material and space in relation to the local situation and climate, can provide comfort and well-being for its inhabitants, with a minimal environmental impact.

This thesis also explores how architecture can not only protect but also connect human dwellers to the outdoor climate, linking seasonal change to the everyday life. We believe that with a low-tech approach, sustainability can be addressed in a more holistic view.

This thesis has a research by design approach, where the local situation and vernacular reference projects are studied along the design iterations. The main design tools are physical modelling and climatic design principles, in order to find a close relationship between the local situation and climate, the materials used and the spaces they create.

**keywords:** vernacular, low-tech, site specific, multi-family dwelling, well-being, seasonal living, housing qualities.

## student backgrounds

Elin Lidén

### Academics

Master's degree in Architecture and Planning Beyond Sustainability (2019-2021)  
*Chalmers University of Technology*

Bachelor's degree in Architecture and Engineering (2014-2017)  
*Chalmers University of Technology*

### Architectural Internships

Erséus arkitekter (2020)  
*Gothenburg, Sweden*

Felippi Wyssen Architekten (2017-2018)  
*Basel, Switzerland*

Martin Lindholm

### Academics

Master's degree in Architecture and Planning Beyond Sustainability (2019-2021)  
*Chalmers University of Technology*

Bachelor's degree in Architecture (2015-2018)  
*Chalmers University of Technology*

### Architectural Internships

Christ & Gantenbein (2018-2019)  
*Basel, Switzerland*



elin.l.liden@gmail.com



martin.j.lindholm@gmail.com

## contents

<i>part 1</i>		<i>part 5</i>	
<b>introduction</b>	9	<b>design concepts</b>	49
introduction	11	volume concept	51
aim	12	economization concepts	53
research question	12	seasonal living and zoning concept	55
delimitations	13	ventilation concept	57
methods	14	load bearing concept	59
reference master thesis projects	15	heating concept	61
reading instructions	15		
<i>part 2</i>		<i>part 6</i>	
<b>background</b>	17	<b>design proposal</b>	63
definitions	19		
dwelling architecture and technology	21	<i>part 7</i>	
low-tech architecture	23	<b>discussion</b>	79
well-being in the home	25		
climatic design principles	27	<b>references</b>	86
conclusion	28		
<i>part 3</i>			
<b>vernacular reference study</b>	29		
<i>part 4</i>			
<b>the site</b>	35		
Local climate	37		
Johanneberg	39		
the site	41		
site analysis	43		
solar study	44		
wind analysis	46		
conclusion	48		

*Part 1*

# *Introduction*

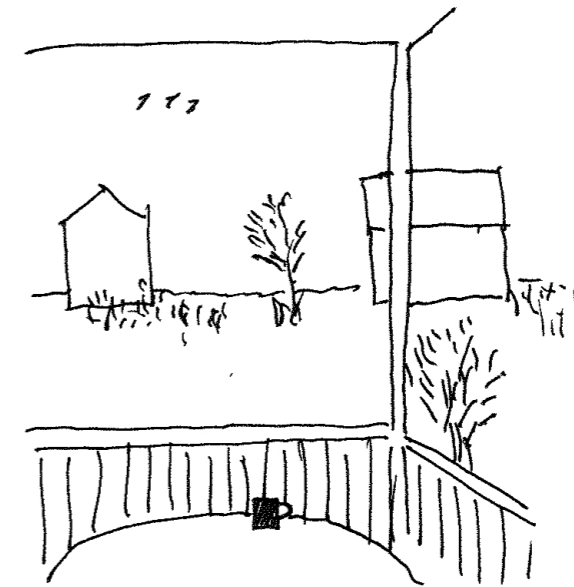



Figure 1. Vernacular Swedish Ryggåsstuga (Falbygdens museum, 2018).

## introduction

“A building is a machine for living” is one of the most famous statements of Le Corbusier and one of the most influential and interpreted ways of understanding dwelling architecture during the 20th century. During this time, the dwelling has moved from being self-organized and adapted to its local conditions, to become a complex and expert profession based industry. Facing the climate crisis of today, the building industry is also proving to be one of the worst industries when it comes to environmental impact, where the following aspects will be the addressed in this thesis:

- The complexity and high-tech focus of the industry *loss of understanding, loss of control for the user, dependency of experts, high maintenance.*
- Lack of connection between architecture and its local conditions and resources *loss of connection to place, climate, seasons, familiarity of materials.*
- An unsustainable construction chain *wasteful, high processed, decrease of materials values in composite and chemically joined elements, short term solutions.*
- Failure to address human well-being *plastic and toxins in materials, dry air, allergies, chemical treatments, connection to outdoors.*

### *Learning from the vernacular*

We believe that, in order to be sustainable, a building cannot work as a machine. A sustainable building needs to be a product of its local situation and climate, where materials and space synergize to create qualitative environments. Vernacular architecture can today be viewed as a rich resource of sustainable and low-tech principles, where adaption to local climate, use of local materials and building methods resulted in buildings that harmonized with its surroundings.

We believe that by learning from low-tech and vernacular principles, contemporary architecture cannot only respond to global sustainability goals, but also generate spatial qualities that support our well-being.

## aim

This thesis aims to take critical inspiration from and reinterpret vernacular principles in a low-tech design proposal for a multi-family dwelling in the area of Johanneberg in Gothenburg. The aim is a design where the composition of material and space in relation to the local situation and climate, can provide comfort and well-being for its inhabitants, with a minimal environmental impact.

The aim is however not a romanticism of the past, but a translation of relevant knowledge with the possibilities and restrictions of present day and the urban context in mind.

## research question

**How can vernacular principles be translated to a multi-family dwelling in an urban context?**

*How can low-tech architecture support well-being in a multi-family dwelling?*

*How can architecture be formed by its local conditions and climate?*

## delimitations

To allow focus on exploring vernacular and low-tech principles and their qualities for human dwellers, this project will not deal with the questions of the local ecosystem or planning for other species. The vernacular translations will not focus on food production or closing nutrient loops, but on spatial and tectonic aspects.

To aid the spatial investigations and to assess the estimated environmental impact of the design, a basic LCA of embodied carbon (GWP) in the materials used will be calculated. Due to the difficulty to make energy calculations on climatic designs, the feasibility of the outcome will be verified on a basic level using indoor climate principles from literature.

To find inspiration for low-tech solutions and principles adapted to the local climate of Gothenburg, a few vernacular dwellings from the region of Västra Götaland will be analyzed from the time period of ~1600-1900.

## methods

This thesis has a research by design approach, where the process consists of three main parts: site analysis, theory and design iterations.

Since this thesis is exploring a low-tech approach to dwelling, the starting point of the project will be the site and identifying its local characteristics and constraints. This will be done through climate analysis, site investigations and literature studies.

The theoretical input consists of a case study of a few vernacular West Swedish dwelling typologies, where conclusions will be translated into the design iteration. Theory on well-being, focusing on architectural qualities of the home defined by Centre for Housing Architecture (CBA), and aspects of comfort will also be studied and used as evaluation criteria in the design process. This will be done through literature studies.

The design part is an iterative process where the findings from the site, as well as the input from the reference studies and theory are translated, iterated and evaluated. This is carried out using physical models and climatic design principles as driving design tools.

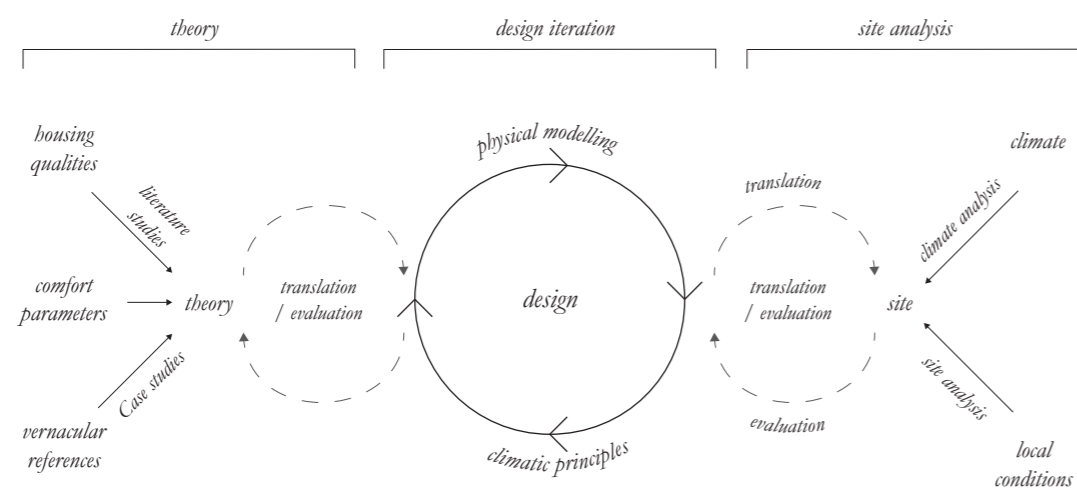

Method of master thesis.

## reference master thesis projects

*Tales of the Revived* - Sandra Moberg and Josefin Eliasson, 2019

*Förünn å Förünn* - Ida Lundgren and Sara Bergås, 2020

*Material Matters* - Alina Molnár and Gustaf Sjöberg, 2020

### contribution

While mentioned thesis projects have discussed material use in a low-tech and circular way, this thesis intends to build on this knowledge with a holistic approach and integrate aspects of indoor climate as a part of the architectural whole.

Although this thesis leans on a theoretical framework, the main emphasize and contribution of the thesis will be manifested in design. With a low-tech design, we wish to add to the discussion of how sustainable housing can be achieved.

## reading instructions

This booklet is divided in 7 parts:

- part 2 introduces the low-tech approach and the theoretical framework.
- part 3 contains case studies of 3 West Swedish vernacular dwelling typologies.
- part 4 introduces the site of the project.
- part 5 describes the design concepts
- part 6 shows the final design proposal.
- part 7 reflects and concludes the project.

*“Passive and low energy design helps the building take advantage of the climate when it is advantageous, and protects the building from the climate when it is not.”*

*- (Hans Rosenlund, 2001, p. 10)*

Part 2

## *Background*

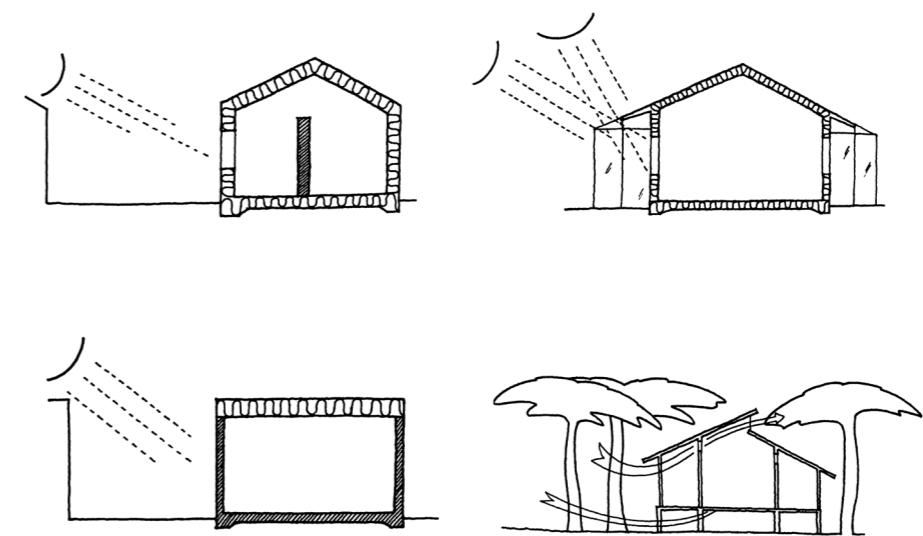
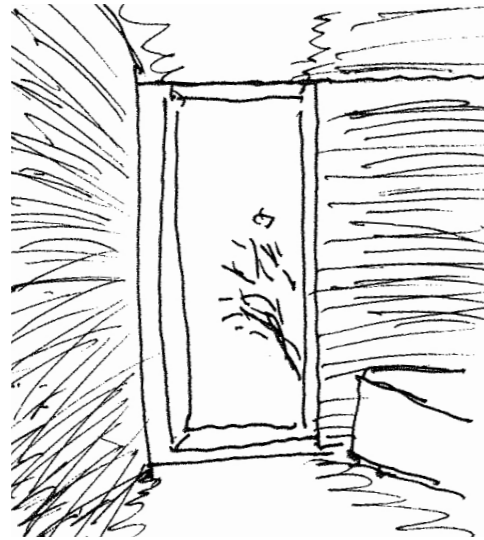

Figure 2. General design principles for four different climate zones (Rosenlund, 2001).



## definitions

<b>Low-tech</b>	Local, passive, low cost, easy to understand, maintainable without expertise.
<b>Vernacular</b>	Traditional architecture without architects, characterized by adaptation to local resources, climate and traditions.
<b>Climatic design</b>	Design approach using elements of nature such as sun, air temperature, wind, plants, to create comfortable and energy efficient buildings (Heiselberg, 2004, p.296).
<b>Passive system</b>	A system that is not mechanical, but driven by processes of nature.
<b>Well-being</b>	“A good or satisfactory condition of existence; a state characterized by health, happiness, and prosperity” (Dictionary.com, 2019).
<b>Comfort</b>	The feeling of content with an indoor climate, made up of a number of measurable physical, chemical, biological and cultural factors.
<b>Weather</b>	“The state of the atmosphere with respect to wind, temperature, cloudiness, moisture, pressure, etc.” (Dictionary.com, 2019).
<b>Climate</b>	“The long-term weather properties, indirectly observed through statistically secured weather observations during a longer time period” (SMHI, 2021).



Figure 3. Construction of Hallonbergen, Sundbyberg (Gösta Nordins arkiv, 2021).

## dwelling architecture and technology

During the 20th century, dwelling architecture in Sweden has changed from being a product of a local building tradition, local materials and a local climate, to become a complex machinery of high-tech, high processed components, standardized for a globalized world.

This is a development that started on a small experimental scale during the 1920's, inspired by the modernist movement in Germany, introducing a future optimistic fascination for prefabrication and modern technology, together with an urgency of improving living standards for the working class that had moved from the country side to become factory workers in densely populated cities (Nylander, 2018). In Sweden, the ideas were scaled up during the flourishing economy after world war two, and was sped up and cemented during the 1960's and 70's, in the construction of the million homes program. During the record years, the housing construction in Sweden changed from regional scale, craft-based practices to a large scale, prefabrication-based industry. As a result, a few large-scale construction companies are still dominating the Swedish building industry today.

During the record years, a housing crisis was solved and the social standard of housing was lifted in Sweden, but the development has also brought consequences for the Swedish building industry and for dwelling architecture. Although only a few generations ago, the new construction paradigm that was developed during the record years has efficiently let the knowledge of building craft and low-tech solutions be overlooked. Instead, the specialized expert professions of architects and engineers have developed and become increasingly divided.

This division is visible in the Swedish building code, where technical characteristics of buildings is assumed to be possible to regulate without a relation to the buildings form (Lundgren, 2019, p. 13). The complexity and fragmentation of the building industry is as a result also reflected in the buildings produced, resulting in a separation between building systems, building components and the architectural space.



Figure 4. New Barrid village.  
Hassan Fathy, Egypt 1963 (Bertini, 2010).



Figure 5. Marika-Alderton house.  
Glenn Murcott, Australia 1994 (Murcott, 1994).



Figure 6. Maison Latapie.  
Lacaton & Vassal, France 1993 (Ruault, 2018).



Figure 7. 2226 office building.  
Baumschlager Eberle, Austria 2013 (Hueber, 2013).

## low-tech architecture

Low-tech or low technology, is in an architectural context an approach that is questioning the predominantly high-tech approach in architecture, and instead suggesting that architecture can and should take the role that high technology has taken over in modern time: where architecture itself, in its composition of material and space in relation to its local situation and climate, provides a healthy indoor climate and environment for humans. Where high-tech components require resource intensive continual change, the low-tech approach is striving towards less complexity and more user understandability, at a low cost and maintenance that does not require experts of high technology.

The local situation, its climate and culture is of great importance in this view, leading to site-specific designs. Since this approach suggests a merge of building systems, building materials and architectural space into a whole, it requires a merging of the worlds of the architect and the engineer.

References of architects having this approach can be found in different parts of the world during the 20th century. Charles Correa in India, Hassan Fathy in Egypt and Geoffrey Bawa in Sri Lanka are pioneers in working with architecture that engages with the local climate and where the architectural space itself forms the building systems. More modern examples are Ralph Erskine in Sweden, Glenn Murcott in Australia, Lacaton & Vassal in France and Baumschlager Eberle in Austria.

As a time before high technology, knowledge and inspiration can be found in local vernacular architecture, where buildings by default had a strong local anchoring. It is however not a romanticism of the past, but a translation of relevant knowledge with the possibilities and restrictions of present day in mind.

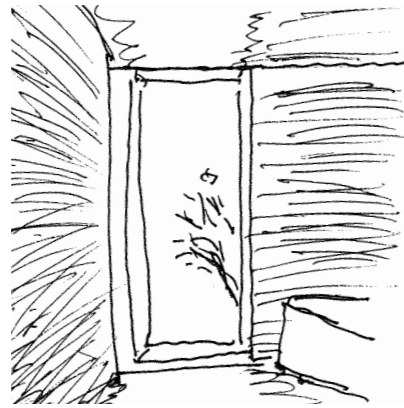
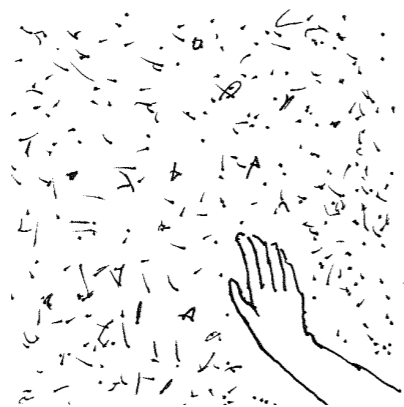
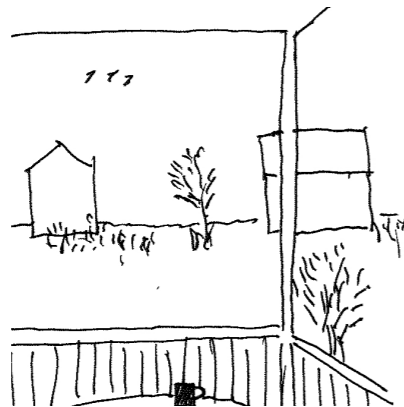
*movement**materiality**spatial extension*

*Architectural qualities that can have a positive impact on well-being, defined by Hanna Morichetto.*

## well-being in the home

As we spend 90% of our lives indoors and 65% in our homes, it is easy to say that the interior and immediate surrounding of the home is of great importance to our overall well-being (Norsk Treteknisk Institutt, 2016; Harvard t.h. Chan, 2019). Well-being can be approached from different aspects, where this thesis focuses to address selected aspects of both unmeasurable spatial qualities within the field of architecture, as well as measurable aspects of *comfort*, a term most commonly used within indoor climate engineering.

### *spatial qualities*

The dwellings potential to support health and well-being is studied by Hanna Morichetto (2019) at the Center for housing architecture at Chalmers, who raises how viewing the dwelling as an enriched environment can give new insights. She raises three areas of architecture, *spatial extension*, *movement* and *material and detailing*, that are of importance for both cognitive and social stimulation. For example, a space with multiple views is shown to be important for the inhabitant's well-being, where the ability to orient themselves in the environment supports the ability to create a "sense of place" (Sternberg & Wilson, 2006).

### *comfort*

From an engineering point of view, well-being is linked to properties of the indoor climate that is measurable and understood with data from qualitative studies on experienced comfort by humans. Comfort is often divided into *thermal comfort*, *humidity*, *light quality*, *air quality*, *sound quality* and *ease of adjustment* (Block, Bokalders, 2010). Comfort is however also dependent on personal and cultural aspects, such as age, clothing, metabolism and level of physical activity.



Humidity



Thermal comfort



Light



Air



Sound



Ease of adjustment

*Aspects that affect an inhabitant's comfort with the indoor climate. (Block, Bokalders 2010)*

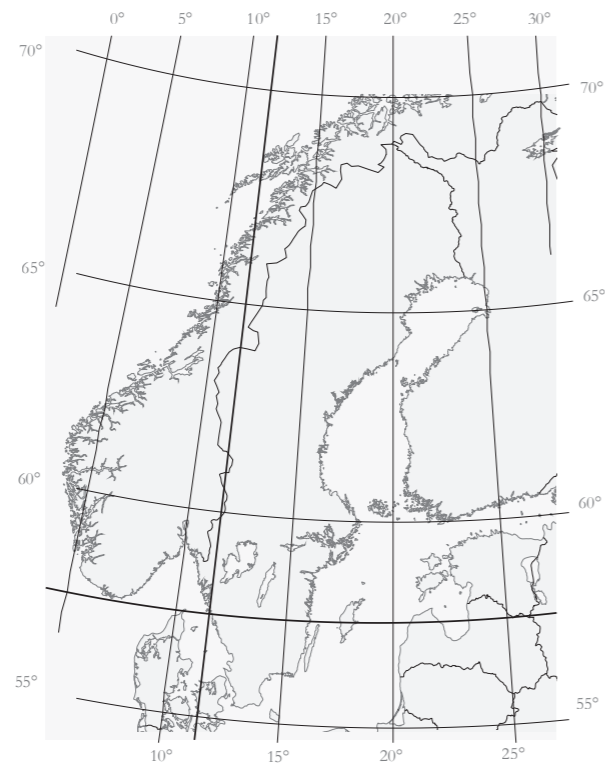

The location of the site of this thesis is in Gothenburg, Sweden. Due to the proximity to the ocean, the local climate is described as cold-temperate to warm-temperate by SMHI (2009).

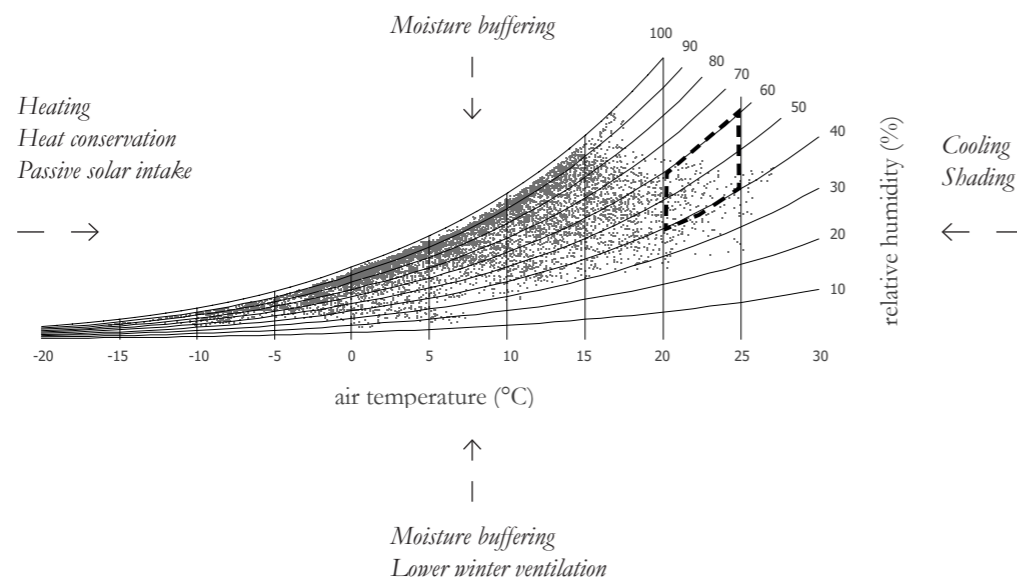

Psychrometric chart of Gothenburg from the tool Climate Consultant. Each dot represents the relative humidity and air temperature of every hour of an average year. Suggestions are given how to push the dots towards the indoor climate comfort zone, between 40-60% relative humidity and 20-26 degrees indoor temperature.

## climatic design principles

How do you affect the indoor climate with the help of architecture, without introducing high-tech climate systems? Since the indoor climate is a direct result of the outdoor climate, the starting point is the site of the project in relation to its local climate. Hans Rosenlund (2001) brings up four different general climatic strategies for housing in the four different climate zones defined by Wladimir Köppen during the 1930's, which are *Cold climate*, *Temperate climate* (which is often divided in *warm-temperate* and *cold-temperate climate*), *Hot-arid climate* and *Warm-humid climate*. There is a close connection between these general design strategies with vernacular principles from the corresponding climate zone. The climate zones are however generalized, and the local climate of this thesis will be more elaborated in part 4: the site.

The site of this thesis is located in Gothenburg, Sweden, which has a cold-temperate to warm-temperate climate (SMHI, 2021). According to Rosenlunds strategies, a cold climate or temperate climate strategy could be applied.

Another tool we have used is Climate Consultant, which suggests strategies to achieve a comfortable indoor climate based on climate data from Gothenburg, where the need for heating and heat conservation, as well as moisture buffering and shading in the summer is pointed out.

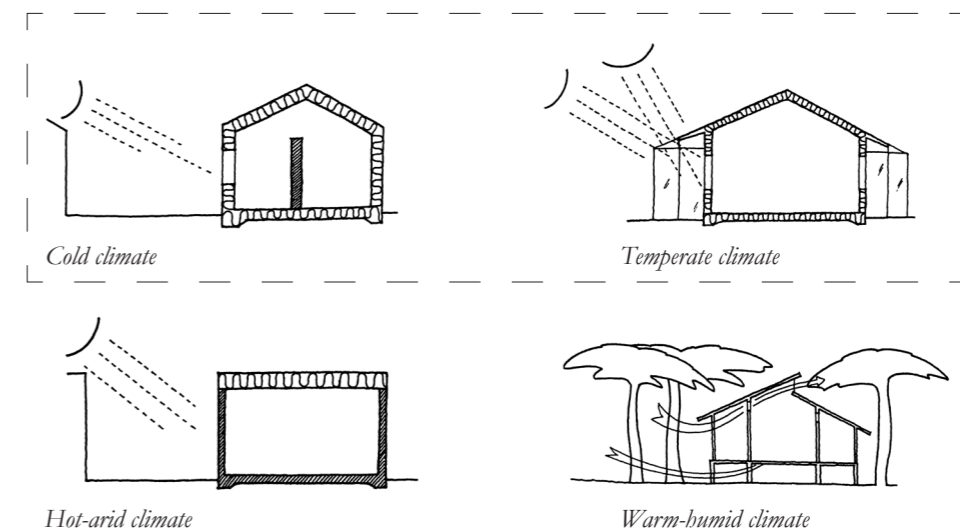

Figure 2. General design principles for four different climate zones (Rosenlund, 2001).

## conclusion

There is a possible connection to be explored between spatial well-being aspects of the home and the more engineering aspects of a comfort in relation to the indoor climate. If comfort is achieved through a low-tech approach, by using architecture itself in its composition of space and materials in relation to its local climate, this could potentially generate spatial well-being qualities that will enrich the design.

The climatic strategies related to Gothenburg can be used as a general frame for the design, strengthened by principles found in the vernacular case study in the next chapter. According to Rosenlunds principles, a well-insulated light construction climate shell combined with seasonal heating and heavy mass for heat storage and thermal inertia is suitable. There will be a need for shading off the southern sun in the summer, and semi tempered zones can be used for heat conservation.

### Part 3

## *Vernacular reference study*

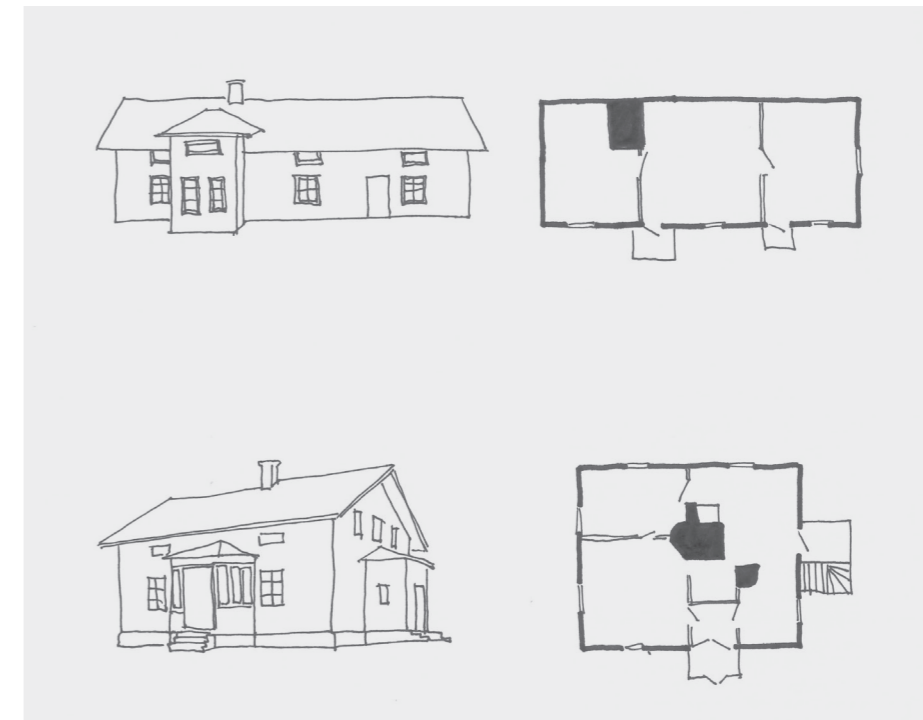

## vernacular dwelling typology study

Three vernacular dwelling typologies in Västra Götaland were studied in search of relevant principles to reinterpret in the design proposal of this thesis. The main aspects we found interesting and relevant are the following:

### *Seasonal use of space*

Large differences in way of life between summer and winter, lead to very different use of spaces. A minimal area was heated in the cold months to conserve energy, whilst summer meant an expansion of the living and working space to unheated rooms and the outdoors.

### *Heat conservation*

Buffer rooms towards the outdoors, double windows and small openings were strategies used to make sure the heat did not escape the dwelling.

### *Spatial organization around heat*

Organizing spaces around a heated core gave a clear social gathering place. Radiant heat from the wood stove gave comfort in the otherwise unheated building.

### *Materiality*

The tradition of massive constructions with timber, can be continued with today's tools and knowledge. Clay is a material that today is viewed as waste, but that holds many qualities of both indoor climate aspects and tactility.

### *Economization*

The close connection of farming and dwelling can be translated into modern concepts of urban farming, to strengthen the connection between neighbours and to place. Although the vernacular typologies would be seen as an unacceptably small by today's standard, today's living space/person can be heavily questioned. Economizing the heated space can be done today with sharing and co-living concepts.

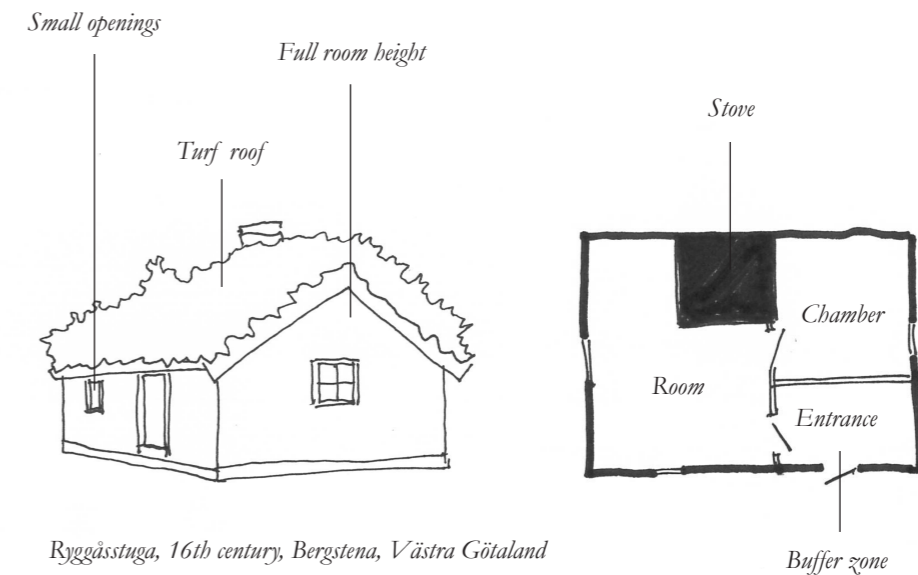

Ryggåsstuga, 16th century, Bergstena, Västra Götaland



Figure 8. Cottage with an elevated position in the landscape (Vänersborgs museum, 2014).  
CC BY-SA



Figure 9. Horizontal timber structure with granite stove. (Franzén, 2018).

### *Ryggåsstuga*

An early common type of vernacular dwelling types in Västra Götaland is called "Ryggåsstuga" (Hansen, Nordström, 2007). The strategies for conserving heat can be clearly seen in the small size of the openings in between rooms and to the outdoors, as well as in the turf covered roof and buffer entrance zone towards the outdoors. The wood fired stove was a central piece of the home, a place used for cooking but also for heating, and as a result a social gathering place in the dark and cold times of the year.

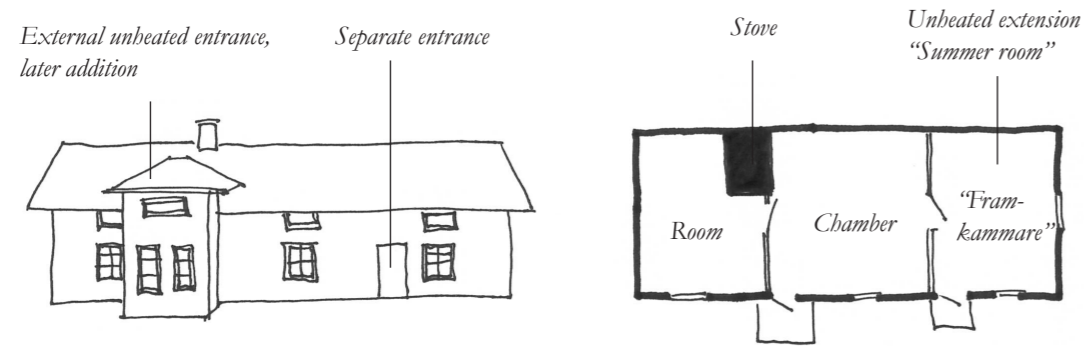

*Framkammarsstuga, 17th century, Hällesåker, Lindome Västra Götaland*



*Figure 10. Wooden cladding to protect the timber structure (Björnäng, 2015). CC BY-SA*



*Figure 11. Interior clay finish for air-tightness (slöjd och byggnadsvård, 2021).*

### *Framkammarsstuga*

Another common dwelling typology in Västra Götaland is called “Framkammarsstuga”, which was common during the 17th century in West Sweden (Hansen, Nordström, 2007). This type of cottage is similar to a “Ryggåsstuga”, but with an additional room is added, a “Framkammare” which was most commonly kept unbeated and used as expansion of living space in the summer. This type of dwelling usually also had a cold attic, which could also be used as an additional sleeping space in the summer. Due to deforestation issues in western Sweden, the region was early to clad the timber structures to protect them from weather (Slöjd och byggnadsvård, 2021).

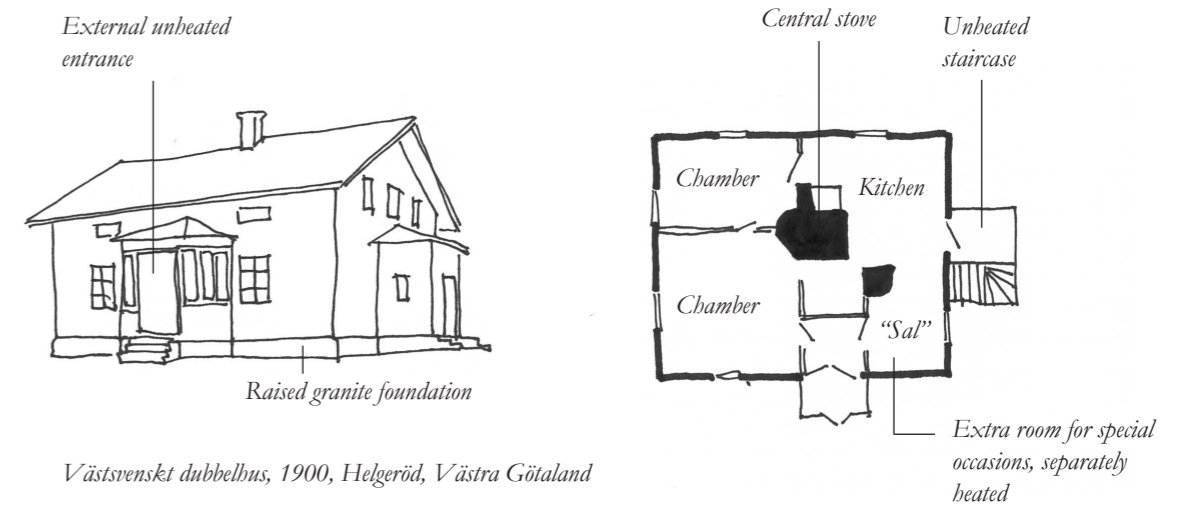

*Västsvenskt dubbelhus, 1900, Helgeröd, Västra Götaland*



*Figure 12. Raised granite foundation (slöjd och byggnadsvård, 2021).*



*Figure 13. Single glazed window with interior winter pane (slöjd och byggnadsvård, 2021).*

### *Västsvenskt dubbelhus*

In west Sweden, one dwelling typology became especially popular during the 19th century and is even named “Västsvenskt dubbelhus”, a West-Swedish double house, which is referring to the doubling of the depth of the dwelling, where the heat source as a result is located as a central core. In this way, more rooms could be heated and even a semi heated upper floor could be introduced. Removing the heat source from the facade lowered the heat loss through the outer walls. This typology also had an exterior buffer entrance zone, as well as a high foundation out of granite, which is a local resource on the west coast.

*“The globe is divided in longitude and latitude degrees. And each crossing point has its certain climate, its certain plants and winds. As an architect, you have to try to understand the difference of life in each point.”*

- Sverre Fehn (Hill, J, 2012, p.276)

Part 4

## *The site*

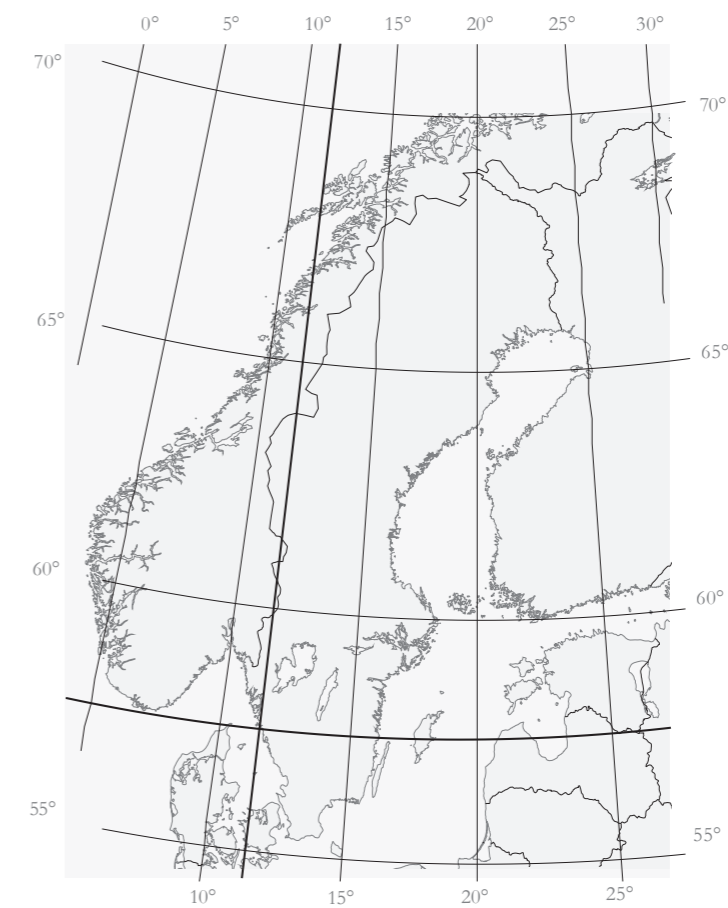



## local climate

Gothenburg is situated on the west coast of Sweden and the climate is largely shaped by its proximity to the ocean. In combination with being positioned south of the Scandes mountain ridge, makes the region exposed to rain and moisture throughout the year (SMHI, 2021).

### *Seasons*

The coastal climate results in smaller yearly differences than other regions in Sweden, with mild winters and rainy summers. However, a changing climate can generate extreme weathers with both heat surges and strong storms.

### *Weather*

It is known that the most common subject for small talk in Sweden is the weather. Although we spend most of our time indoors, the perception of the outdoors is a very important reference point in our everyday life. The Gothenburg climate creates a characteristic sideways rain that is often referred to as a part of the city's identity.

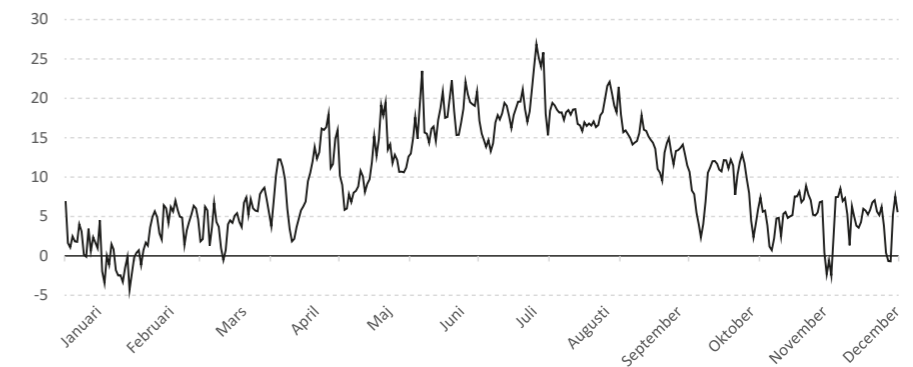

*Average day temperature (SMHI, 2021)*

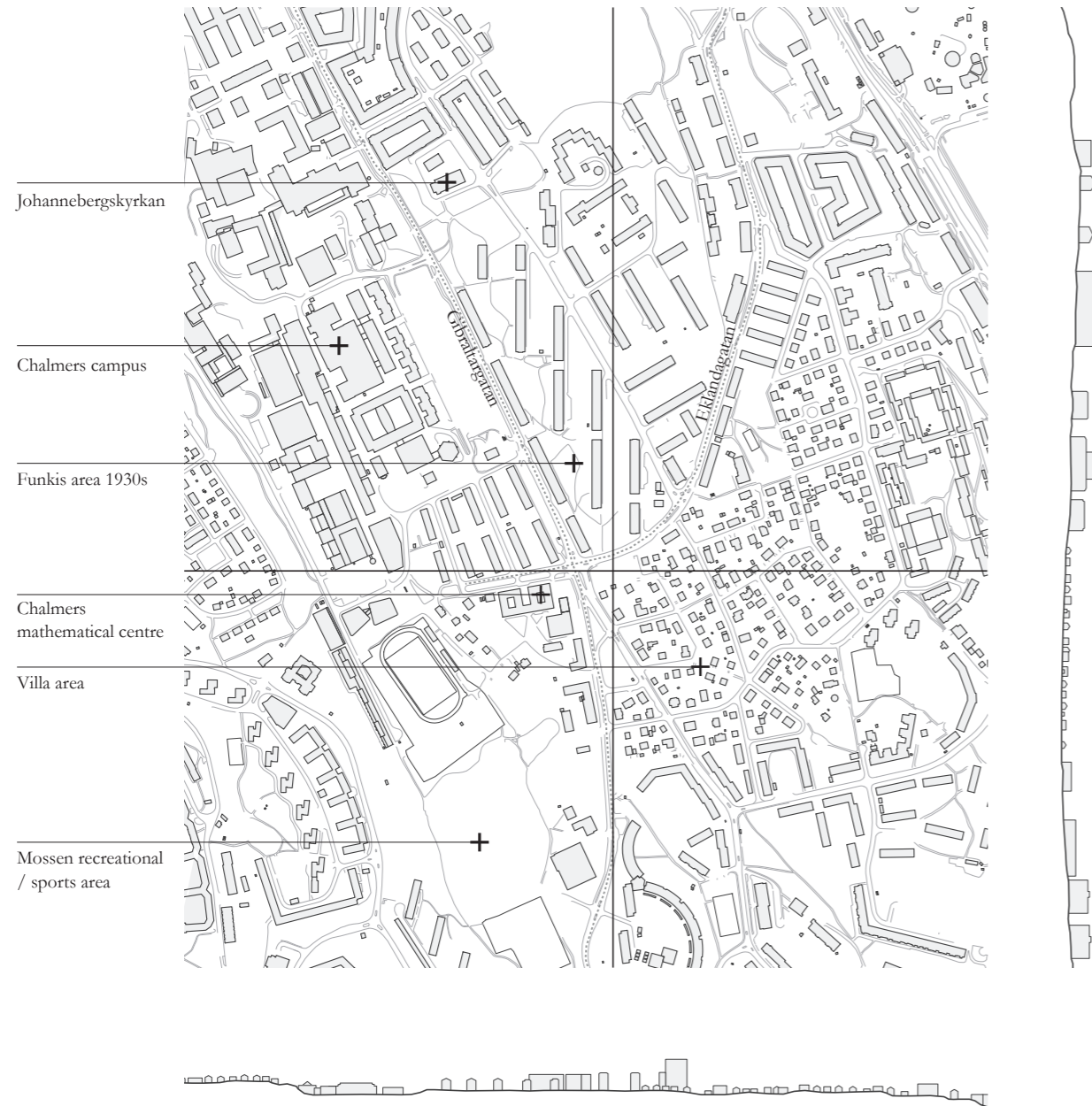

## Johanneberg

The site is located in the area of Johanneberg, just south of Gothenburg's city centre. The area was peripheral and largely rural until the start of the 1920s (Lönnroth, 1999). North of the plot is a distinct "funkis" housing area, drawn by Uno Ahren in 1936. The area marked the shift of the modern movement in Gothenburg and is characterised by its elevated topography, open park landscape and 6-8 storey lamellas in bright colors.

South of the site is a villa area with a more rural character. The houses range from late 19th century to today but follow a common roof height and withdrawn placement from the streets.

Chalmers University of Technology was relocated to its current plot in Johanneberg in 1926 and has expanded since, attracting a young population to the area. The mathematical centre was built in 1990s west of Gibraltargatan, introducing a new typology at the site where the villa area previously continued west.

### *main typologies*



*Funkis lamellas*

27 m<sup>2</sup> living space / person  
31 m<sup>2</sup> land / person  
(eniro, 2021)



*Villas*

46 m<sup>2</sup> living space / person  
212 m<sup>2</sup> land / person  
(eniro, 2021)



### the site



The site is today an overgrown gravel area, where two previous building were demolished a few years ago. Today, a four storey office building is planned to be constructed on the site with an underground garage.

The corner location makes the site very visible in the urban surrounding. The sharp change in building heights and typology, demands attention to handle the scale of what is added on the site.



Traffic, noise. (Noise data from Göteborgs stad, 2021).

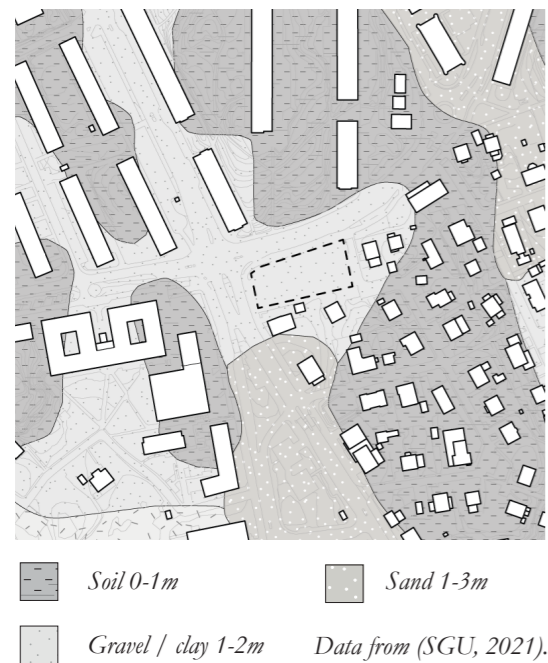

Soil 0-1m
  Sand 1-3m  
 Gravel / clay 1-2m
 Data from (SGU, 2021).



Green areas, vegetation

## site analysis

### *Functions*

Public functions are scattered along Gibraltargatan and is exchanged to primarily private villas south of Eklandagatan. The large passing flows makes it suitable for a public function in the corner.

### *Noise*

Both Gibraltargatan and Eklandagatan are connecting city districts south of Johanneberg and have large passing flows. A frequent traffic of busses and transports creates noise issues that requires to establish a quiet side for added dwellings (Göteborgs stad, 2021).

### *Geology*

Bedrock is situated 1-2 meters below the surface of the site, with a few deeper places where natural clay occurs. Otherwise, the site is filled with gravel and sand after earlier demolitions. At 2 - 2,7m depth is the water table found (SGU, 2021).

### *Vegetation*

The area has in general a varied vegetation in the shallow soils. The villa area has a diverse vegetation with both fruit trees and bushes, whilst the open park landscape between the lamellas contains larger trees and green lawns. Along Eklandagatan and on one side of Gibraltargatan are tree rows in linden planted.

### solar study

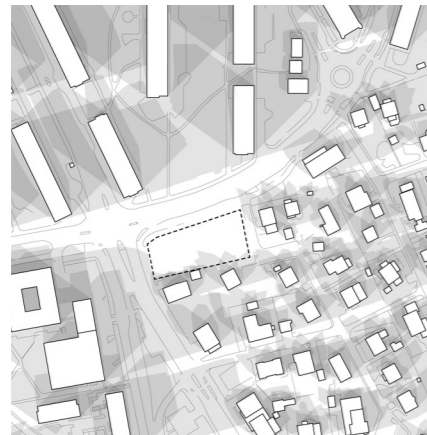

Spring 09:00, 12:00, 15:00, 17:00

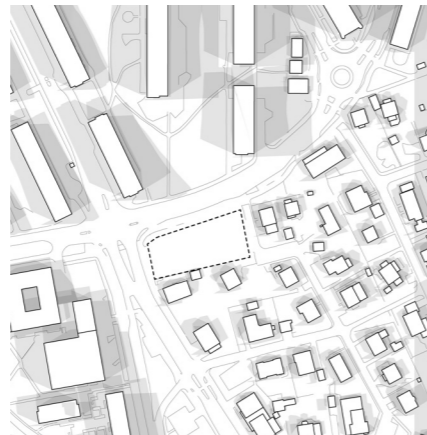

Summer 09:00, 12:00, 15:00, 17:00

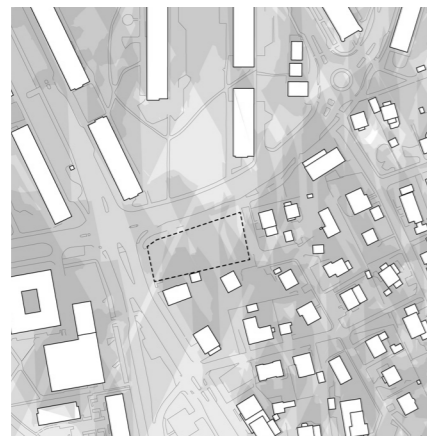

Winter 09:00, 10:00, 12:00, 14:00

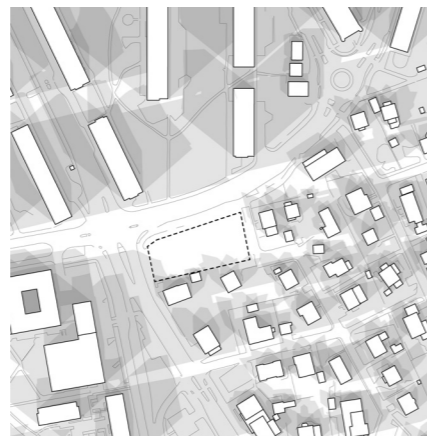

Autumn 09:00, 12:00, 15:00, 17:00

The site is well exposed to sun throughout the year and has very good lighting conditions.

Adding a building on the site would mainly shade the street and the slanting park space on the other side of Eklandagatan.



Being a cloudy region, daylight shifts between gloom and sharp glare as the clouds move. The long darkness of the winter creates a contrast to when the light returns in the spring with

the long summer nights as a climax, before the light slowly diminishes again during autumn and the return of the dark and cold.

### wind analysis

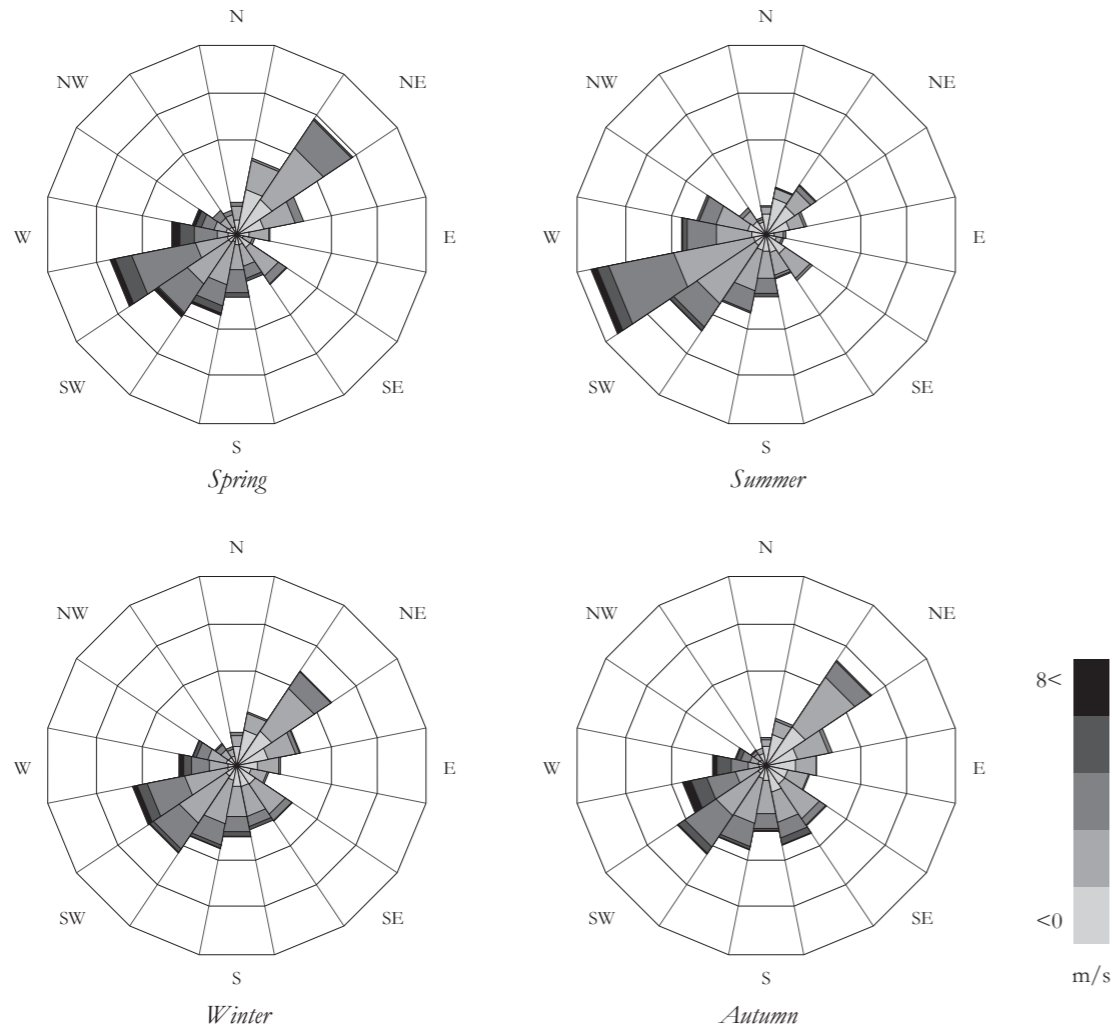

The wind generally comes from south-west throughout the year, with highest speeds in summer and autumn.

The wind data is collected from SMHI:s measuring station in Gamlestaden, 5 km north of the site (2021).

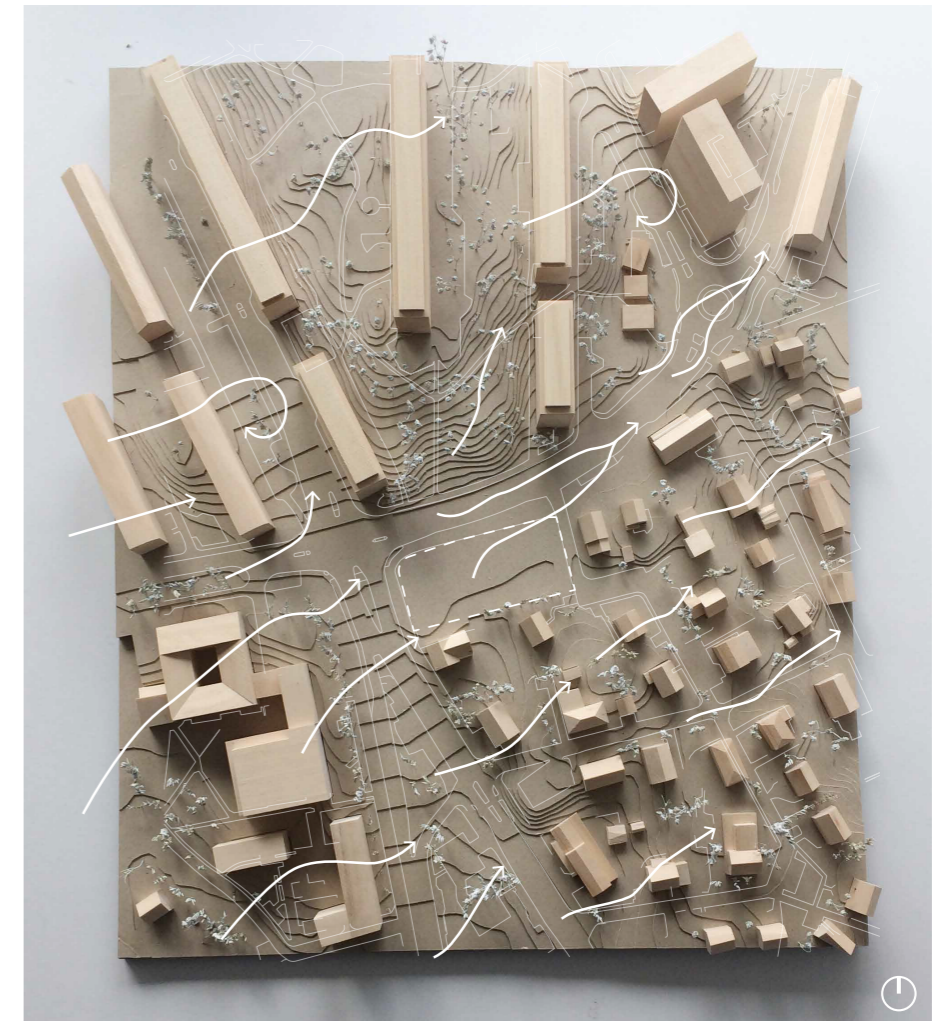

Site model, 1:500

The sites position in an elevated terrain sloping upwards towards north, makes the wind a present element.

South-western winds can create a wind tunnel effect along Eklandagatan whilst southern winds can accelerate along Gibraltargatan.

## conclusion

The various aspects of the site together show the possible qualities an added dwelling block can give to the surrounding. From an urban point of view, clearer defined streets and new public functions would enhance values of the area. Climatic wise, an addition has limited impact on light conditions for public spaces or nearby dwellings. Working with differentiated volumes can reduce winds along Eklandagatan and create a pleasant micro-climate in a yard space towards the south. Maintaining visual connections across the site and respecting the neighbouring areas character, an addition can offer new dwellings typologies in the area.

## Part 5

## *Design concepts*

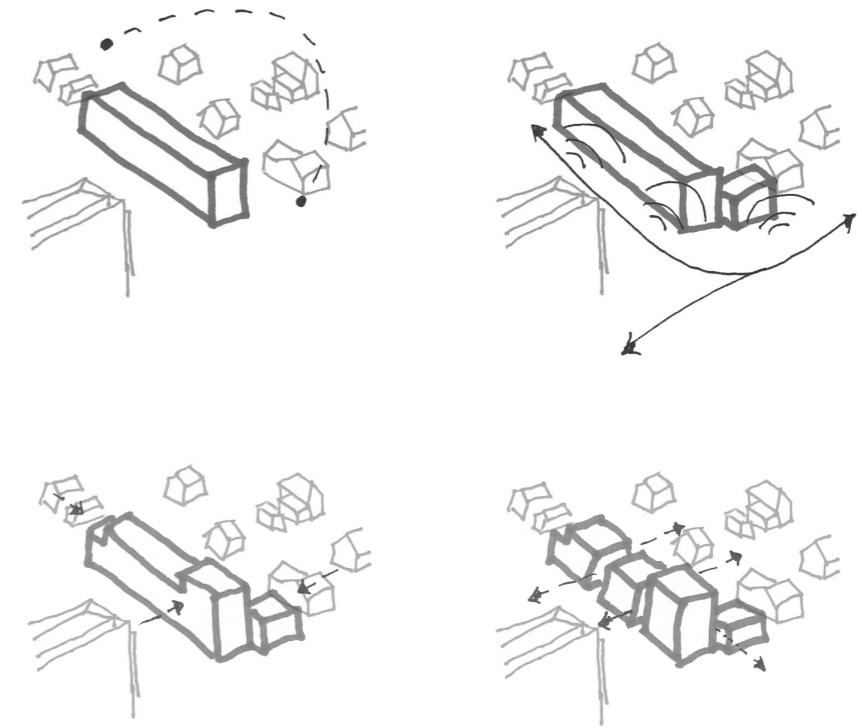



## volume concept

The design process started with studying the local conditions through physical model building alongside the analysis of the local situation. From the site and climate analysis, we identified the following parameters as important in shaping the volume.

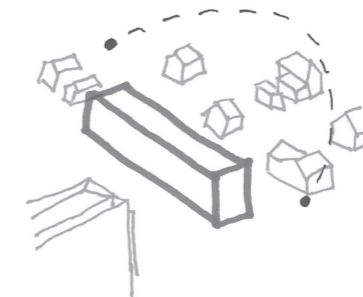

*Climate*

North-south orientation for winter solar gains and sunny balconies. Possibility to shade off summer sun with horizontal shading.

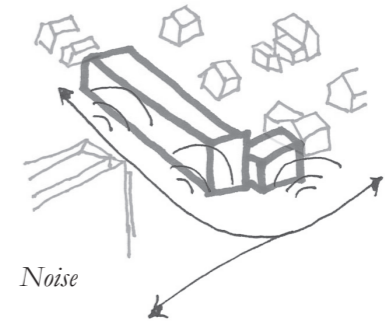

*Noise*

Place the buildings along the two noisy streets to establish a quiet side for the dwellings. Adapt building depth to allow two-sided apartments.

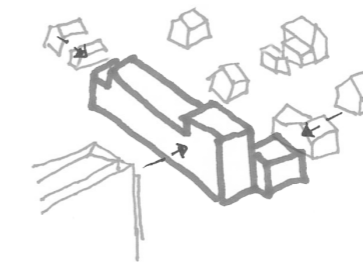

*Scale*

Vary the buildings scale against Gibraltargatan and the neighbouring villas.

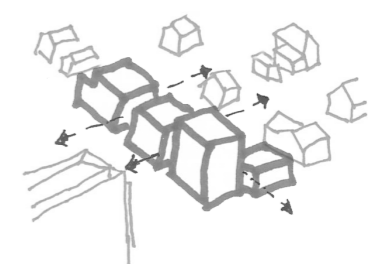

*Porosity*

Maintain a porosity in the built form and visual contact between the areas across Eklandagatan.



Figure 14. Farming in front of a Framkammarstuga (Liljeroth, 2014).  
CC BY-NC-ND

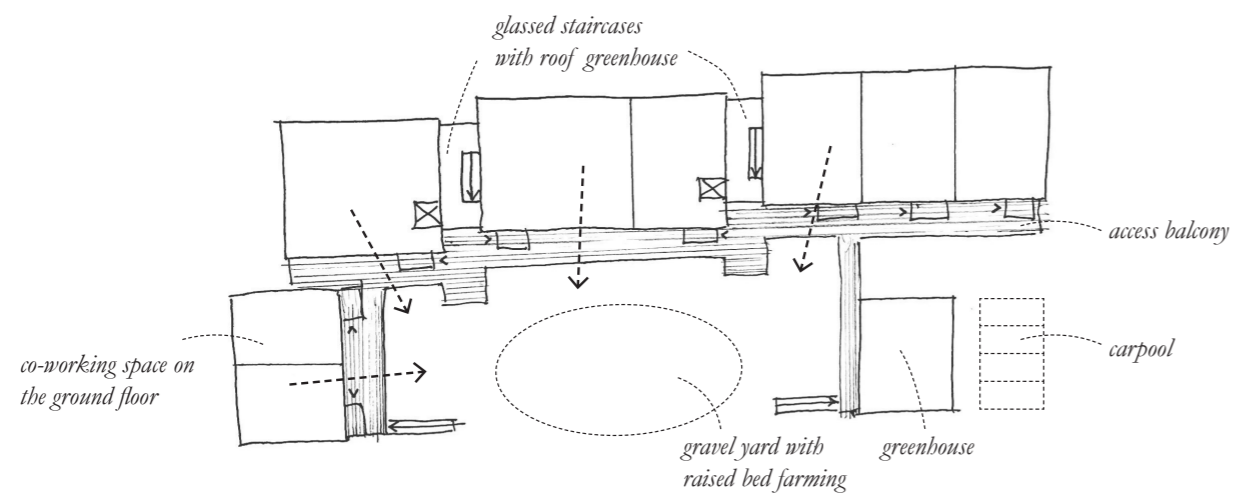

All buildings are connected with the added balcony, with main outdoor spaces oriented towards the yard.

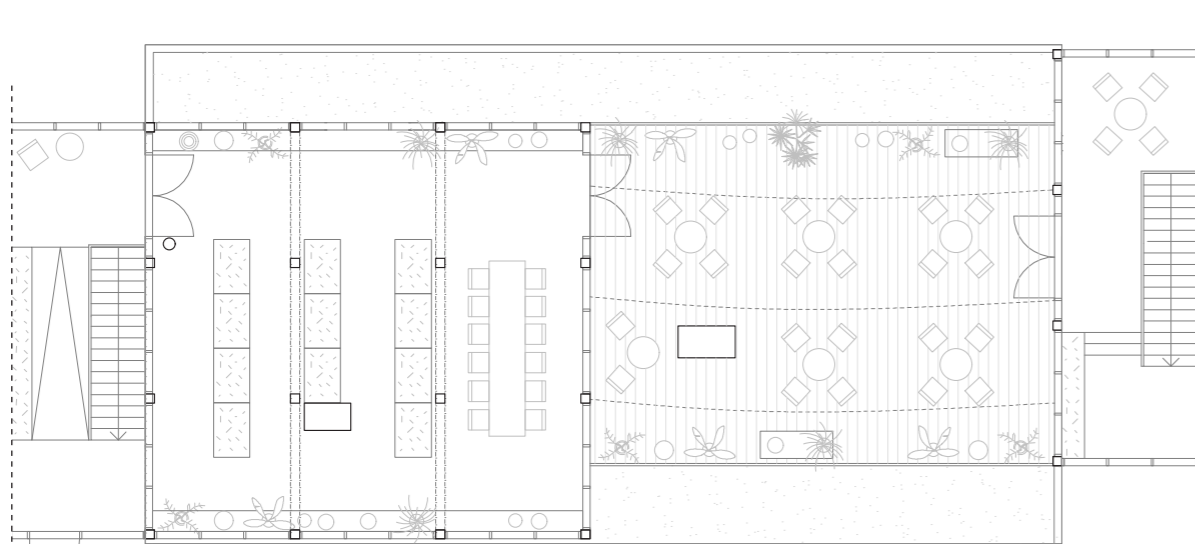

Roof top greenhouse an roof terrace.

## economization concepts

### Access

By extending a horizontal shading concept in the south into an access balcony, a movement zone along the southern facade is added, giving a more low-cost access than adding additional internal stairwells. The orientation of the access balcony towards the common yard give all apartments a strong connection and overview of the common outdoor spaces, and social bonds between neighbours can be strengthened. The vertical access is placed in-between the volumes of the block.

### Increased sharing

Creating the basis for increased social values and economizing of the built space, an emphasis is placed on co-living apartments with decreased private space and increased shared spaces.

In the original detail plan of the site, an office block was suggested. Meeting this with a sharing approach, a co-working space on the ground floor could create a less generic office space with more informal meetings between visiting workers and the dwellers of the block. It also makes a nearby working place possible for the dwellers.

### Local farming

As found in the proximity of every vernacular dwelling, farming has been an important aspect of living and understanding of the origin of our food. By giving space for farming, both in a roof greenhouse, a detached greenhouse and on the yard, a direct connection to the sourcing of food is made.

### Mobility

Replacing today's norms of car ownership with a shared carpool and generous bike parking spaces, sustainable mobility is encouraged and manifested. This allows to avoid basements, with high costs and climate intensive materials needed.



Figure 15. Unheated extension concept of a vernacular Framkammarstuga. The entrance to the heated part of the house works as a buffer zone (Hansen, Nordström, 2007).

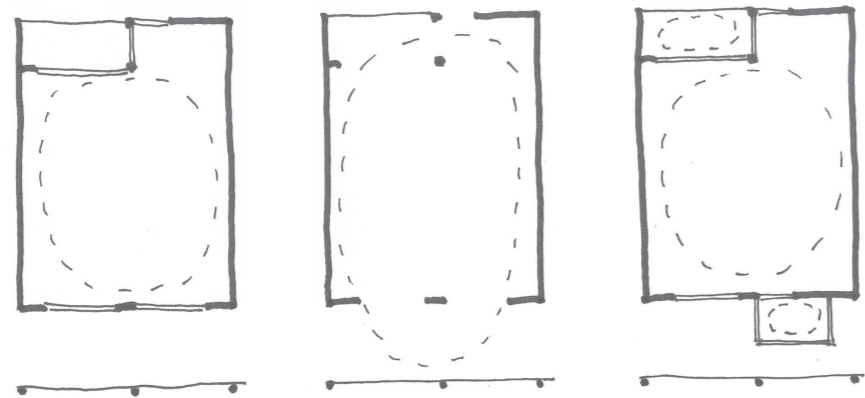

Winter use of apartment space

Summer extension of space

Unheated spaces used separately in autumn and spring

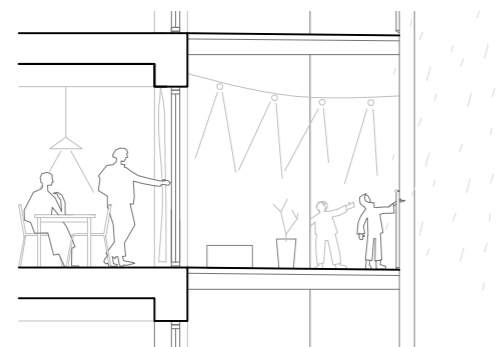

Southern access balcony in a rainy autumn day.

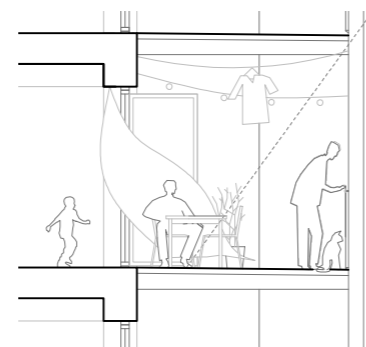

Spatial extension onto access balcony in the summer.

## seasonal living and zoning concept

A quality of a detached house in a vernacular typology, as well as in the villa typologies south of the site, is a close relation to the outdoors, and the possibility to extend your living space in the warmer months into a garden. In our sketches, we intended to create the same relation to the outdoors but in an apartment typology. The access balcony in the south gives the possibility for each apartment to extend or decrease their living space depending on season. The balcony provides the opportunity to stay outdoors during grim weather as it offers protection from the rain, whilst also protecting the facade and making maintenance more accessible.

In vernacular typologies, unheated spaces are used to increase the living space in the warmer months. In our translation, an entrance veranda in the south and a winter garden in the north has remained unheated, and can be added to the living space in the summer and used to prolong the warm season in the spring and autumn. These unheated additions also buffer heat losses and noise from the street in the north, and can be used as cool storage space in the cold times of the year.

By combining the climatic principle of shading and zoning, with the well-being aspect of spatial extension, a closer connection to the outdoors can be established, as well as forming the social infrastructure of the block.

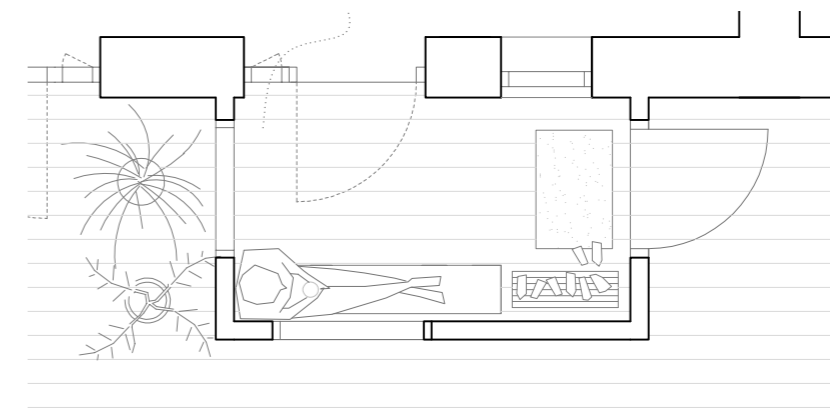

Unheated entrance veranda of an apartment, that works as a buffer zone towards the outdoors. A nice place to extend the fika to in early spring and late autumn.



Figure 13. Single glazed window with interior winter pane. Air is warmed between the panes before it enters the dwelling (slöjd och byggnadsvård, 2021)

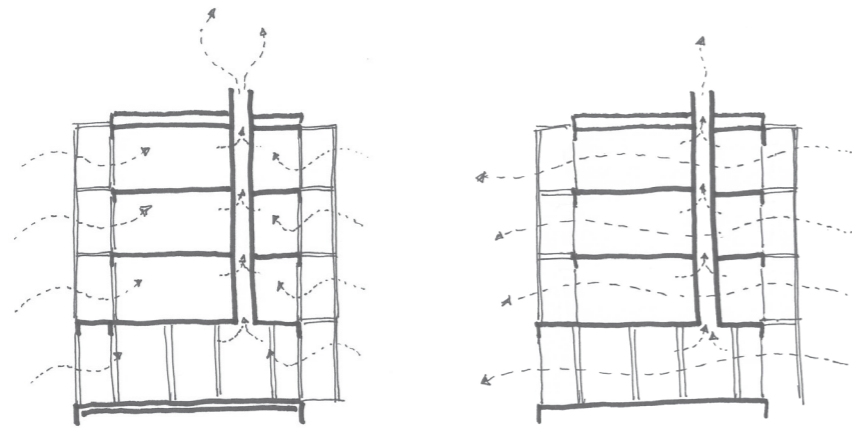

Winter scenario with prewarming of intake air through buffer zones. Exhaust chimney using stack effect.

Summer scenario. Stack effect is complimented with additional cross ventilation.



Model picture of vertical ventilation flap, steered by indoor air quality measuring device.

## ventilation concept

In a vernacular typology, the air was simply taken into the dwelling through untight windows, and taken out through the chimney using the stack effect. The windows could often be complimented with winter interior window panes, which prewarmed the air in the winter.

Translated to our proposal, a window in each room is complimented with vertical ventilation flaps, adjusted after an indoor air quality measuring device, which allows a good indoor climate with minimized energy losses, that the user always can override. Exhaust air is taken from kitchens and bathrooms using the stack effect. As the apartments are arranged between two facades, the users can utilize natural cross ventilation in the hot summer days for extra air flows. To lower heat losses, the apartments have some ventilation windows placed inside the unheated parts of the volume. During the cold months, the ventilation is lowered and the intake air is taken in and prewarmed through the unheated entrance veranda in the south and a glazed winter garden in the north.

In this concept, the comfort aspects of thermal comfort, air quality, and ease of adjustment have been combined with the climatic principle of temperature zoning and the spatial quality of spatial extension, providing an understandable and user friendly way of taking in air into the apartments.

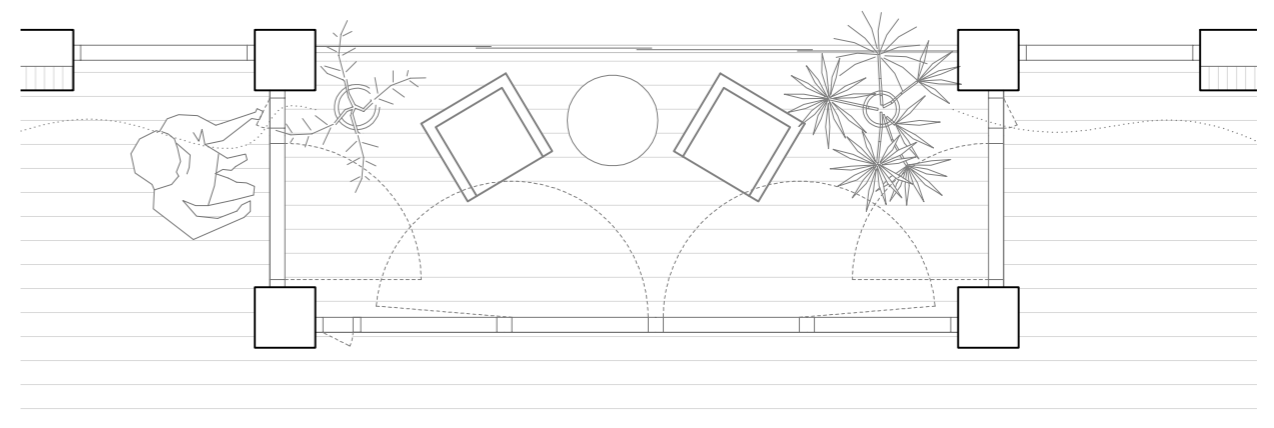

Ventilation windows facing a winter garden in the north of the apartments, to buffer noise and heat losses.

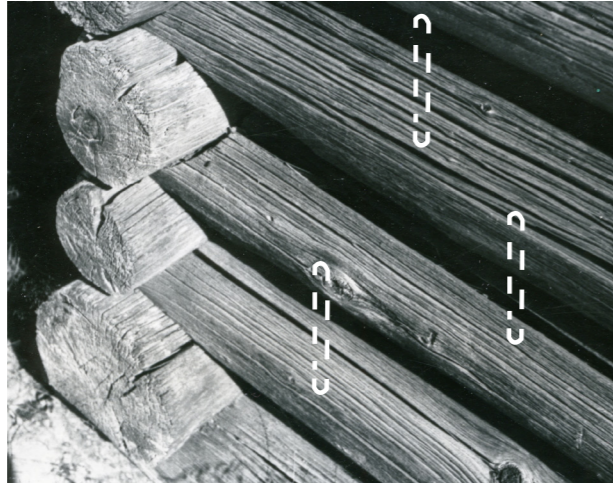
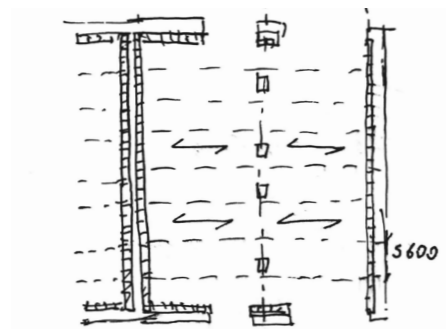

Figure 16. Traditional timber wall with internal wooden dowels (Västmanlands museum, 2018).



Figure 17. Dowel laminated timber structure in residential building, Haus J, Zurich (Spoerri, 2014).



Sketch of load-bearing structure

## load bearing concept

Building in wood has a long tradition in Sweden. Massive timber elements hold indoor climate qualities of moisture regulation and thermal inertia as well as tactile qualities. Today's products of CLT and glulam provide stable elements that can support high-rise building. However, the use of fossil based glues has an increased climate impact and decreased recyclability.

Modern techniques that utilize hardwood dowels to join wooden posts instead of glue, build upon the knowledge found in vernacular timber constructions, utilizing modern tools. By adding the dowels diagonally, the elements become even more stable. The dowel laminated elements give a vertical wooden surface to the interior. The slabs span the apartments width with the support of a timber beam. Externally, the facade cladding is mounted horizontally for easier maintenance.

In this concept, the climatic principle of moisture buffering and thermal inertia is combined with the tactile property of the materiality of wood, a spatial quality related to material and details.

- 22 horizontal wooden panel
- 34x45 vertical batten s600
- 50 wood fibre wind board
- 170 cellulose fill / studs s600
- paper
- 160 dowel laminated timber

U-value: 0,15

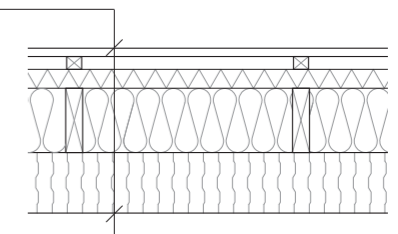

Horizontal section of outer wall

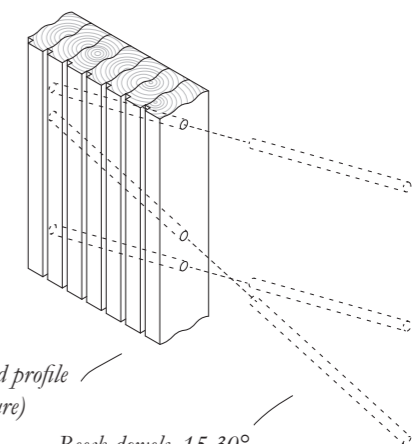

Fir posts, CNC milled profile  
(12-15% wood moisture)

Beech dowels, 15-30°  
(8% wood moisture)



*Vernacular kitchen, the rooms are heated with direct radiation heat from the firewood stove, that also defines the spatial arrangement of the floor plan. Authors own photo.*

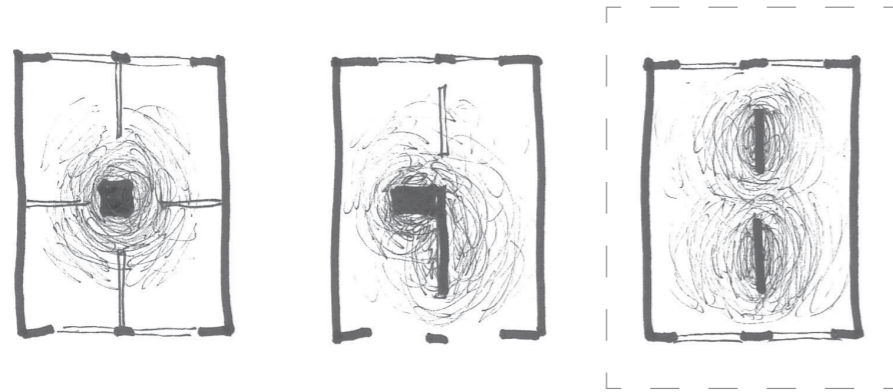

*Sketches of radiant heat sources in an apartment typology. A central heat core evolved into a wall heating concept, where a larger surface can spread warmth and at the same time divide the space.*

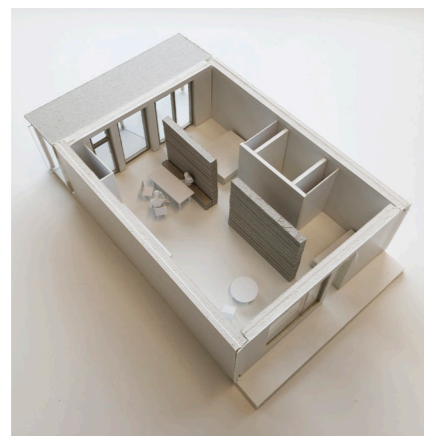

*Sketch model of apartment 1:50, the heat walls gives warmth, thermal inertia and works as a spatial divider of the apartment.*

## heating concept

The vernacular logic of heating has a strong spatial presence, not only for the direct radiating warmth from a wood stove, but also for the way the heat source works as a spatial element you move around, and as a social gathering spot.

The most appreciated heat source by human experience is radiant heat, coming from a large low temperature surface. The most common way of heating housing today, through radiators, is only providing some radiation while most of the heat is generated through convection (movement of air), which is not considered as comfortable (Bokalders, Block, 2010). Today it is possible to achieve both a well-insulated wall and tight windows that does not generate an experienced cold draft. This opens up the possibility to move away the heat source from the facade to become a spatial element again, that can be the very essence of organizing a floor plan.

In the design process, the concept of mass as a spatial divider and a radiant heat source was explored, starting out with a firewood burner as a core of every apartment. The negative health aspects connected to smoke in an urban setting lead to the decision of using the existing infrastructure of district heating. By filling in the load bearing structure with unburnt clay bricks, plastered with clay plaster with water pipes connected to a central water boiler, a warm heavy mass can function as spatial dividers you move around in the apartments, as well as giving thermal inertia and moisture buffering qualities. In warm summer days, the mass stays cool, and in the case of a heat wave, cold water can be run through the mass for cooling.

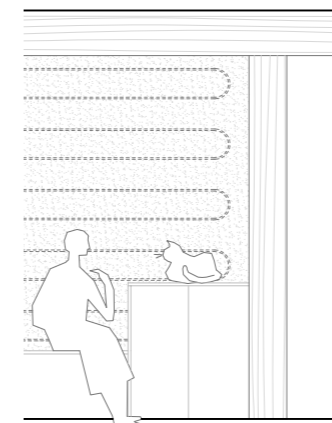

*Elevation of heated wall.*

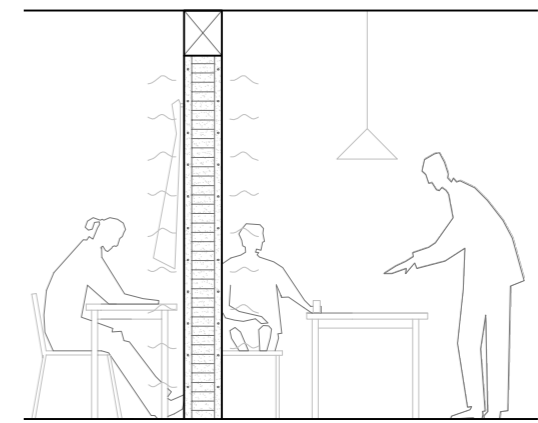

*Sitting and working against a warm mass in the winter, and a cold mass in the summer.*

*Part 6*

*Design proposal*





*View from south, 1:500 model*

The block is shaped as a meeting point in scale, density and expression between the neighbouring areas. Around the block are new trees planted that connects to the street character found on the western part of Eklandagatan and that helps to break down winds.

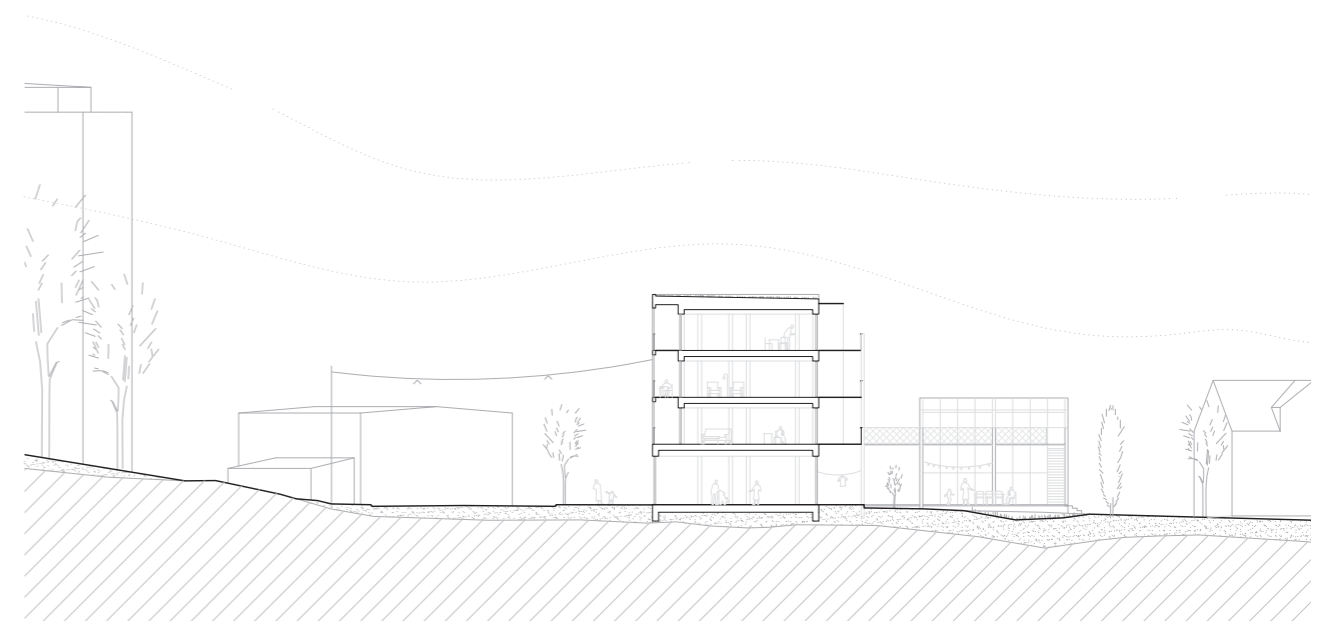

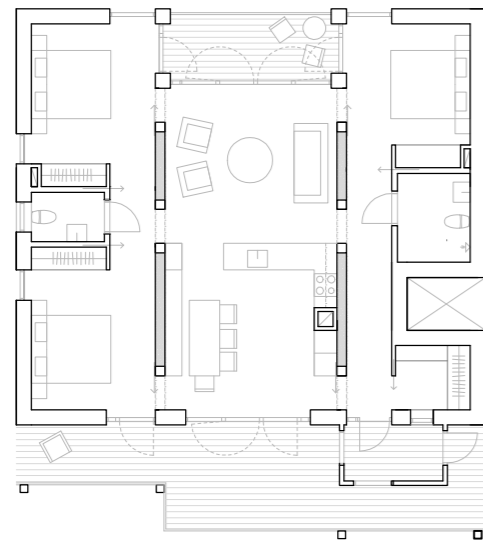

Type A. 4 room co-housing apartment  
105 sqm  
3-6 people

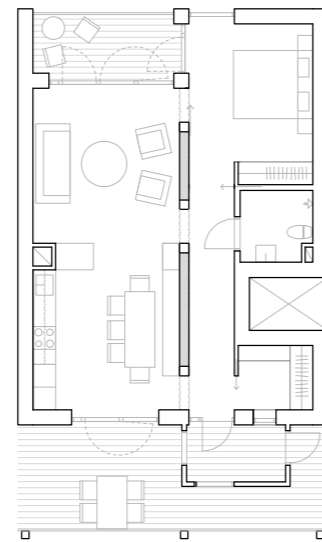

Type B. 2 room apartment  
63 sqm  
1-2 people

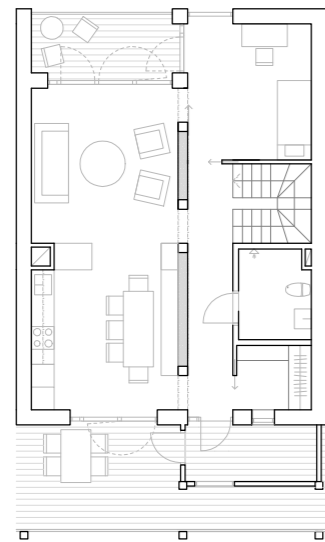

Type C. 6 room duplex apartment  
136 sqm  
5-7 people

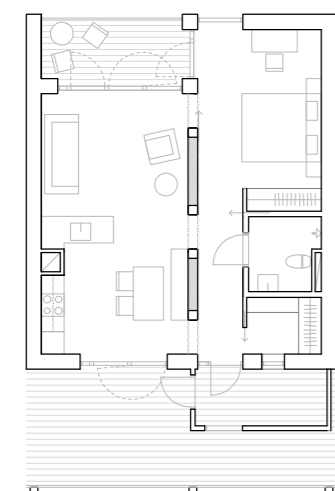
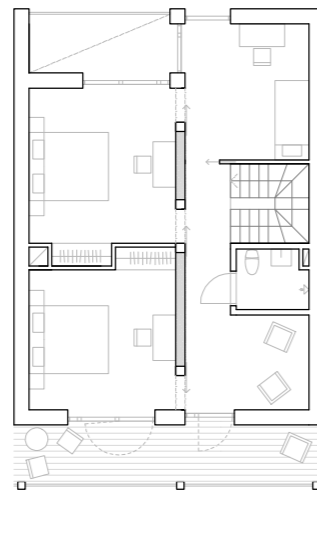

Type D. 2 room apartment  
56 sqm  
1-2 people

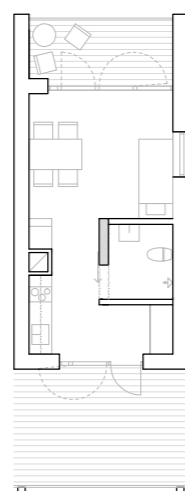

Type E. 1 room apartment  
26 sqm  
1 person

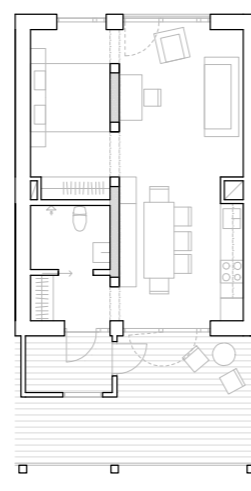

Type F. 2 room apartment  
43 sqm  
1-2 people

## apartment typologies

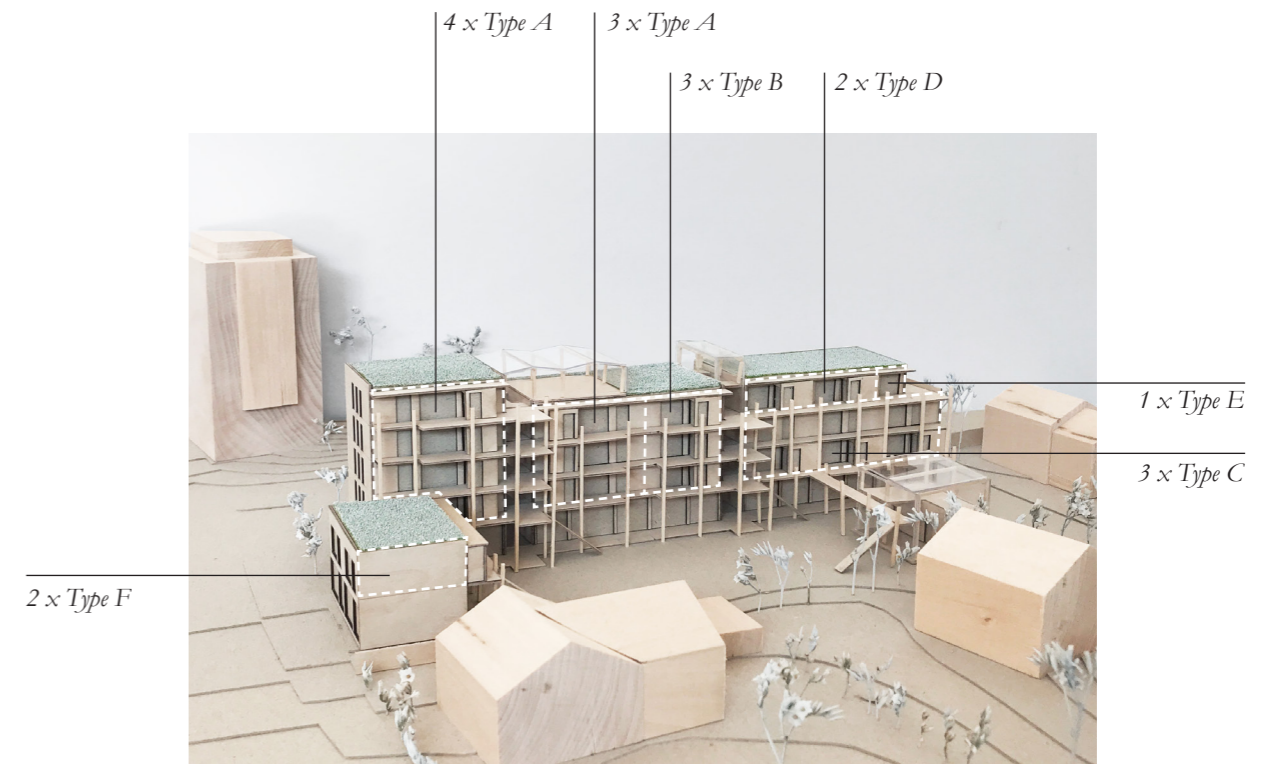

Apartment typologies in design proposal.

The proposal contains a mix of typologies to offer dwellings for varied households. The apartments follow the same logics of wall heating and natural ventilation, as well as stretching between two facades with an entrance veranda towards the yard and a winter garden towards the street. An emphasis is placed on co-living apartments to create a basis for increased social values and sharing, that also reduces the built area per person.

2100 m<sup>2</sup> land      ~24 m<sup>2</sup> living space / person  
3400 m<sup>2</sup> built area      ~32 m<sup>2</sup> land / person

(700 m<sup>2</sup> unbeated)

(1600 m<sup>2</sup> living area)  
(500 m<sup>2</sup> rentable area)

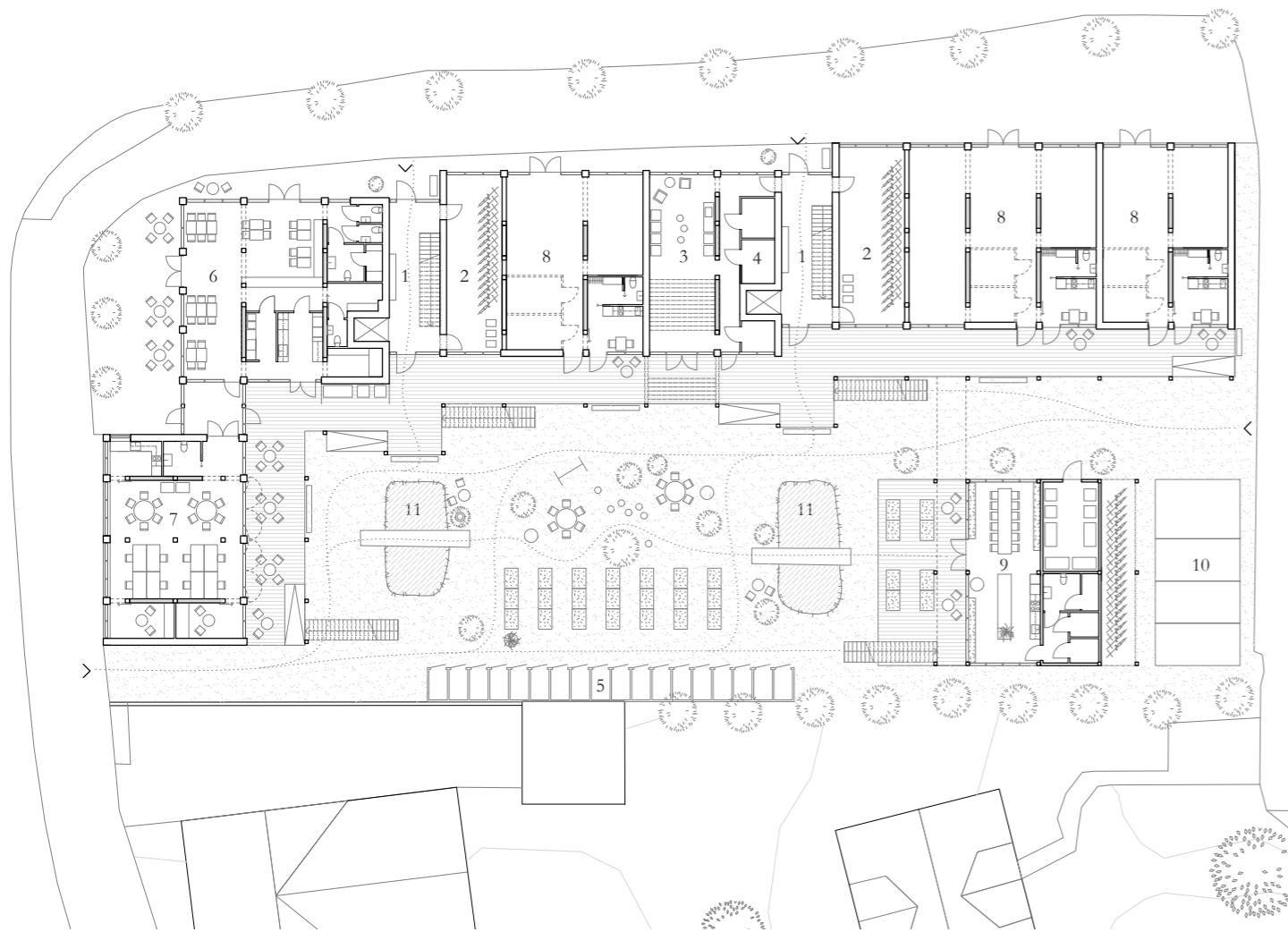

Public spaces are situated along the streets, with a café and connected co-working space in the western part. An outdoor space with evening sun is created towards Gibraltagatan where the café can extend outdoors.

Shared social spaces for the dwellers are situated in the greenhouse and on the roof terrace. Generous laundry and bike rooms are located next to the entrances, that stretch between the facades.

- 1. entrance
- 2. bike room
- 3. laundry
- 4. technique
- 5. storages
- 6. café
- 7. co-working
- 8. rentable space
- 9. greenhouse
- 10. car pool
- 11. rain garden

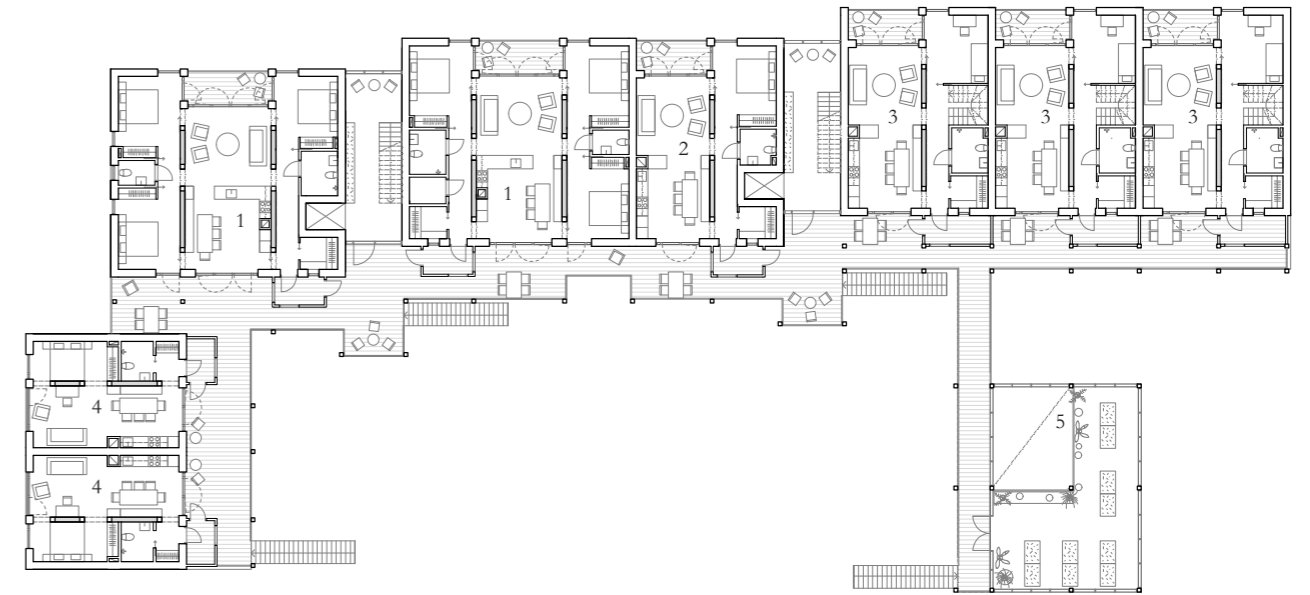

On the first floor, all buildings are connected with the balcony structure, where the added entrances define semi-private spaces. The balcony stretches out to the yard by the staircases to create social spaces and to define building volumes. Additional stairs strengthen the connection to the yard.

- 1. 4-room co-living apartment
- 2. 2-room apartment, type B
- 3. duplex apartment
- 4. 2-room apartment, type F
- 5. greenhouse



facades towards south



facades towards north

Towards north, the glazed staircases are highlighted between the shifted volumes, with an otherwise uniform facade that responds to the ordered character of the neighbouring lamellas.

Towards south, the added balcony structure gives a dynamic expression with its varied depths that speaks to the villa area. The common rooms have wider openings whilst the bedrooms have smaller to provide privacy.



View along southern facade. 1:200 model.

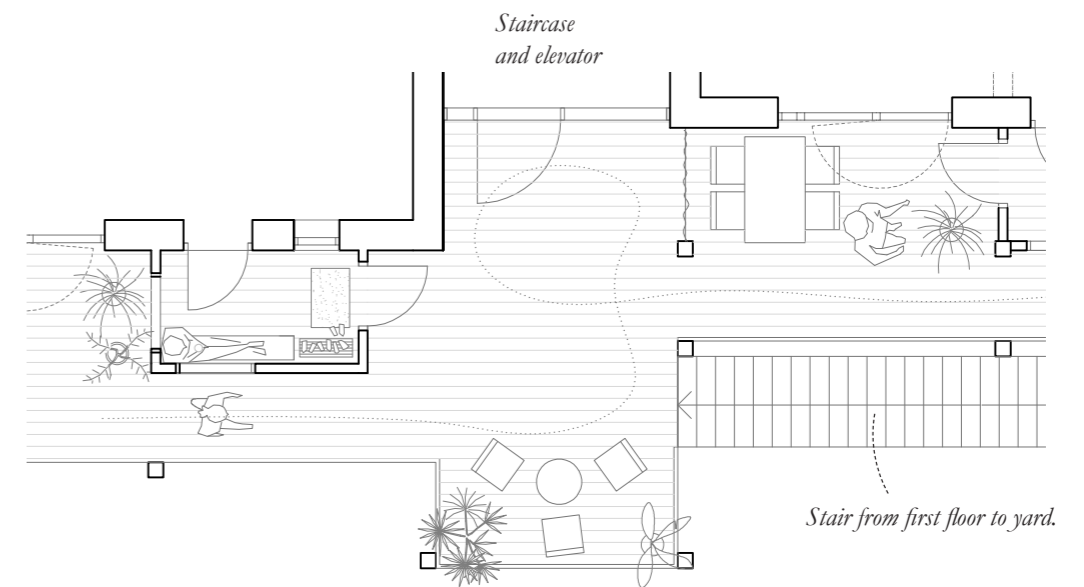

Access balcony in the south. By the staircases the balcony stretches out to the yard to give space for neighbour interactions. External verandas form semi-private outdoor spaces next to the apartments.

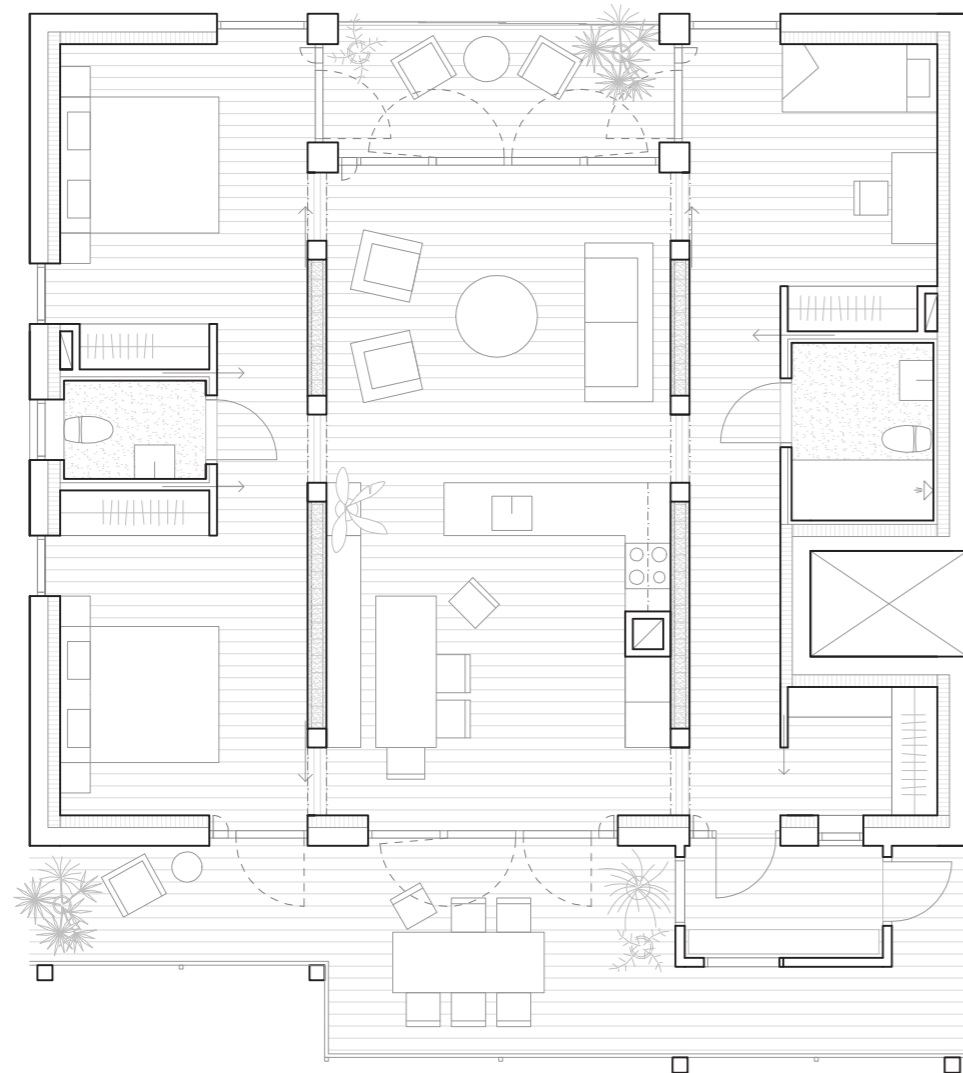

*View from entrance towards kitchen. Social gathering place against the tactile clay wall.*

Zooming in on the 4 room co-living apartment, it is organized with a central common space with private spaces on the sides, divided by the heat walls. The bedrooms have equal sizes to allow for a variety of household-constellations and the western ones can be divided to two smaller. A multitude of spatial connections between the rooms gives freedom of movement and the openness between the two facades gives cross-ventilation possibilities and light.



*Organization*



*Equal bedrooms*

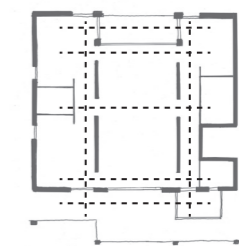

*Movement axes*



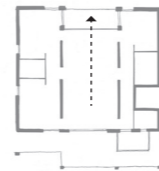

*View from kitchen towards north. The winter garden gives spaciousness and reduces noise from the street.*

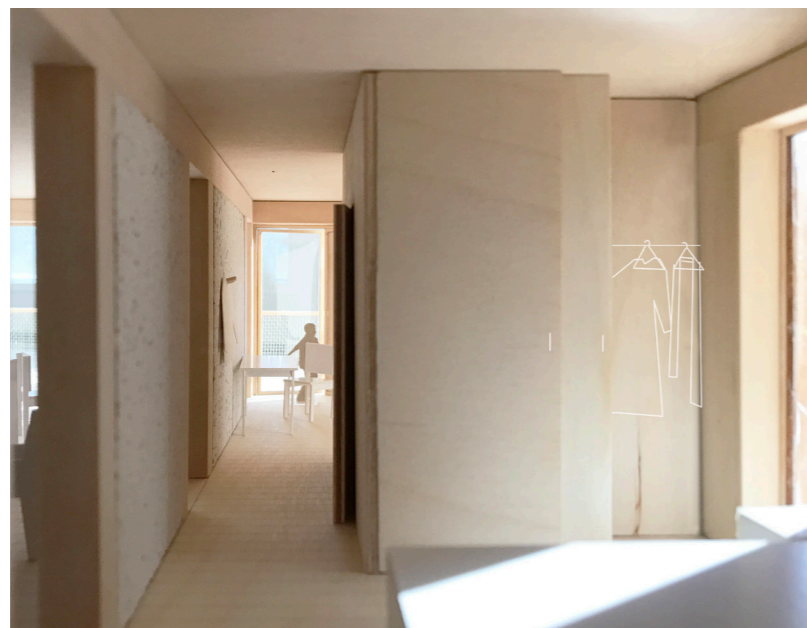

*View between bedrooms along the heavy, tactile walls.*

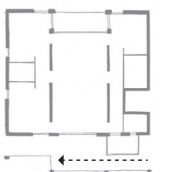

*View along entrance balcony. Varied depths of the balconies bring in light to the social spaces.*

The apartment has a temperature gradient, with warmer social spaces and cooler bedrooms. In summer, the heavy walls thermal inertia helps to stabilize the indoor climate. The rooms towards north have the possibility to enter the glazed balcony that receive late evening sun. In south, the rooms either have direct access to the balcony or to the unheated veranda, that is a comfortable place to enjoy sunny days in early spring or late autumn.

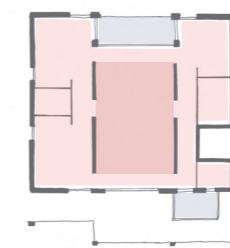

*Temperature gradient*

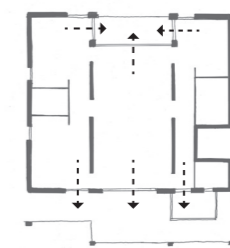

*Seasonal extension*

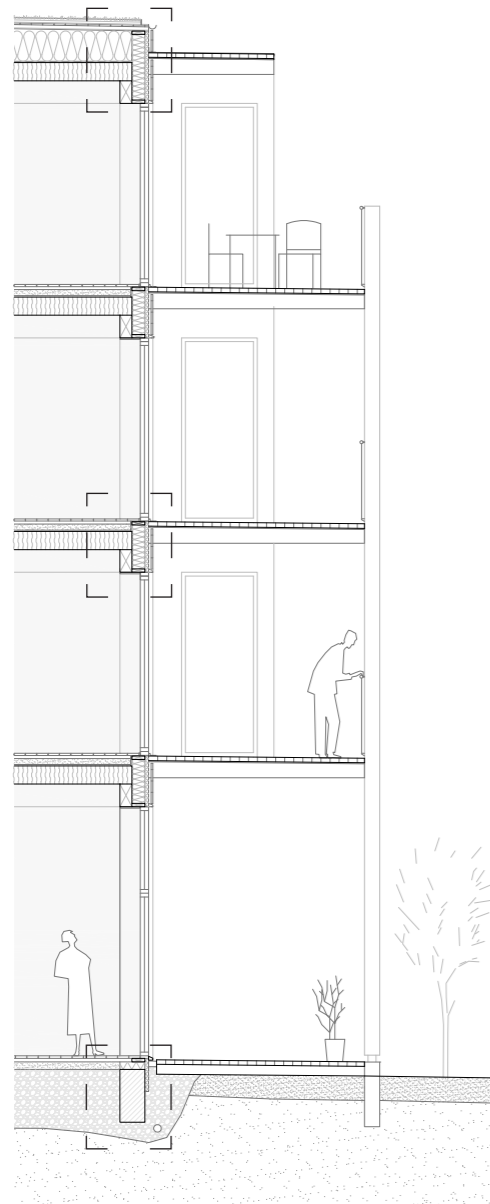

detail section 1:100

The buildings have a sedum roof cover, that helps to reduce stormwater volume on the surrounding. Granite plinths below the load bearing columns provide stability with a low environmental impact.



facade visualization 1:100

Underneath the balconies, a raised wooden terrace gives the ground floor spaces easy access to the outdoors.

1. roof

- 30 sedum
- 30 substrate
- 5 moisture retention
- 5 bitumen
- 22 tongue and groove boards
- 45 battens / air
- 10 wooden fibre board
- 400 cellulose / wooden beams
- paper
- 240 dowel laminated timber

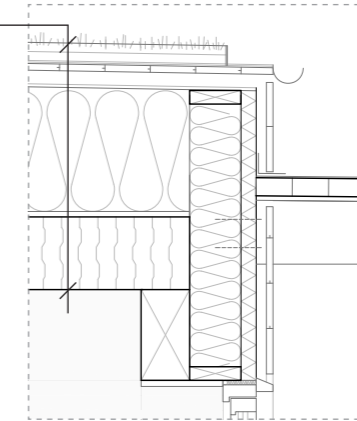

GWP / building element\*  
A1-A3

43 kgCO<sub>2</sub>/m<sup>2</sup> roof

compared to conventional roof:  
(concrete, xps, bitumen)

106 kgCO<sub>2</sub>/m<sup>2</sup>

2. intermediate floor

- 28 spruce flooring
- 40 wooden fibre board
- 80 gravel
- 18 gypsum board
- 240 dowel laminated timber

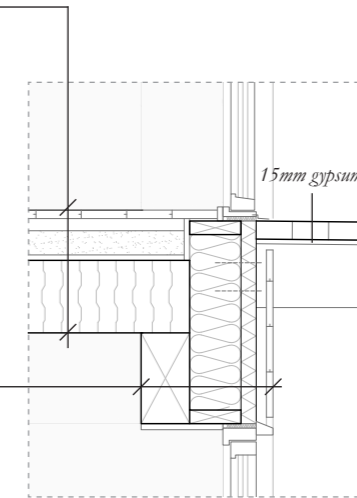

39 kgCO<sub>2</sub>/m<sup>2</sup> floor

compared to conventional slab:  
(concrete, rubber mat, wooden flooring)

71 kgCO<sub>2</sub>/m<sup>2</sup>

3. outer wall

- 22 horizontal wooden panel
- 34x45 vertical batten s600
- 50 wood fibre wind board
- 170 cellulose fill / studs s600
- paper
- 160 dowel laminated timber

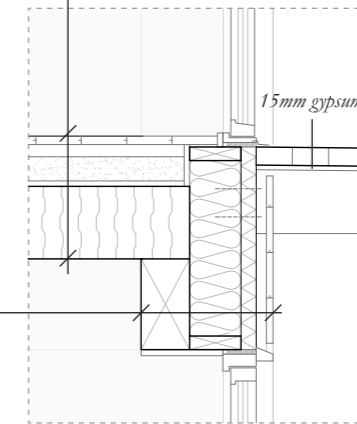

33 kgCO<sub>2</sub>/m<sup>2</sup> wall

compared to conventional wall:  
(concrete, eps, concrete)

83 kgCO<sub>2</sub>/m<sup>2</sup>

4. foundation

- 34 wooden boards
- 10 wooden fibre board
- 45 battens s600
- 100 clay
- 800 basopor

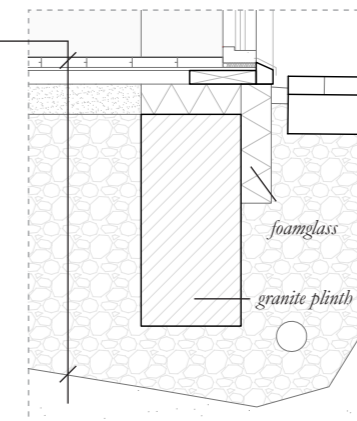

46 kgCO<sub>2</sub>/m<sup>2</sup> foundation

compared to conventional foundation:  
(xps, eps, concrete, rubber mat, wooden flooring)

83 kgCO<sub>2</sub>/m<sup>2</sup>

\* Calculated with values from IBO database. Comparison construction have the same U-values as the proposal.

*Part 7*

*Discussion*

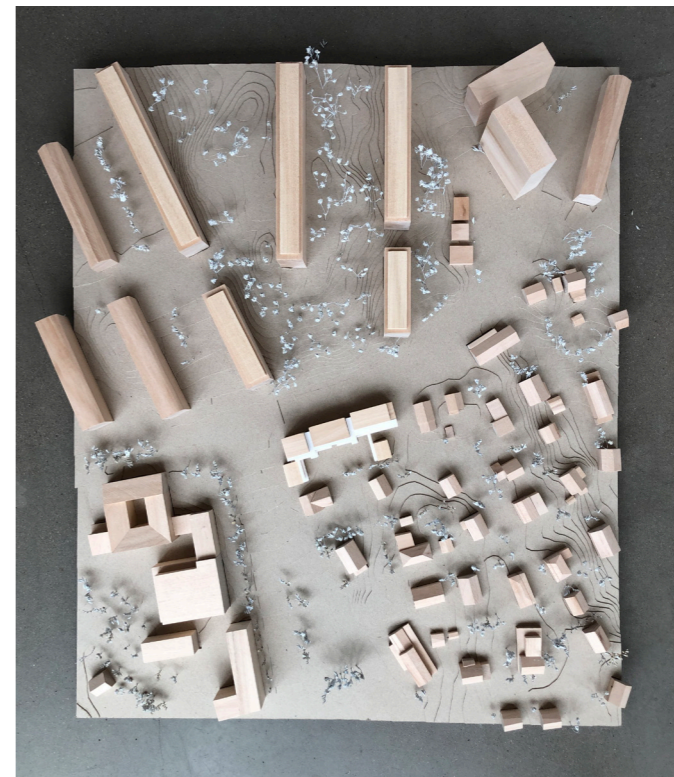

## conclusion

In this thesis, the predominantly high-tech approach in the building industry is criticized for its complexity, lack of connection between architecture and its local conditions, unsustainable material use and failure to address human well-being.

As an alternative, the low-tech approach is lifted for its site-specificity, adaption to the local climate and merging of space, materials and building systems into a whole that supports well-being for the inhabitants. Through taking critical inspiration from vernacular principles, this thesis aimed to study how the composition of material and space in relation to the local situation and climate, could provide comfort and well-being for its inhabitants, with a minimal environmental impact.

In our reading of the vernacular as an interplay between local resources, local climate and building traditions, there are many connections to essential sustainability questions today to be found. For instance, utilizing local resources to the greatest extent, means shifting the view of material sourcing from the global to the local, where local building materials means both renewable and what is today considered as waste. This has been further explored by other master thesis projects, while we chose to focus on spatial and indoor climate aspects.

From the vernacular, this thesis applied concepts of economization, seasonal use of space, zoning, spatial organization around heat as well as constructional concepts utilizing timber and clay. Aspects we found with limited relevance in a contemporary context were in large parts connected to the drastic changes in way of life, with connected spatial aspects of for instance changed need of indoor daylight. Building on tradition, we do not view the “modern vernacular”, as a question of aesthetics or style, but as seeking a site-specificity. Through adapting to local conditions and climate, utilizing locally available materials and infrastructure, together with low-tech and low-cost principles, modern vernacular can from both economically, ecologically and socially sustainable spaces for humans to dwell.

A question is how our approach of translating the vernacular would have turned out in a different site, with higher demands on density, a more complex program or worse climatic preconditions regarding daylight or noise. Some of our concepts, for example the heating system, is possible to apply to a different site, while others, like the access balcony, are direct answers to the sun orientation. There is a restriction of height when building in massive timber, and providing for mobility and storage on the ground floor without building a basements gets more difficult with higher exploitation. A medium density housing, a school or a pre-school project is probably the most suitable scale for this approach.

## *How can vernacular principles be translated to a multi-family dwelling in an urban context?*

In the translation of vernacular principles from a small-scale rural context, to multi-family housing in an urban context, interesting discussions and sometimes conflicting ideas have come up. We were aware that the vernacular is often used as a romantic vision of a sustainable future, with small scale rural living off grid and only dependent on local closed nutrient loops. In this project however, the context is the key, and the urban setting has other preconditions, such as less land use per person, social accessibility, sharing of resources and existing infrastructure that needed to be considered. With a critical reading of the vernacular, this project was about finding the middle ground, where the vernacular and the urban could merge into a typology where sustainability aspects from both worlds meet. The choice of the site was a manifestation of this middle ground, set in between the 8-storey lamella area and the one-family detached villas. Working with a medium density addition, the project rejects the high-density marked-steered development found in urban areas today where basic qualities of daylight is often overlooked, as well as the urban sprawling and individuality of villa areas.

An example where our critical reading of the vernacular is reflected in our design process, was the choice of heat source. A romantic translation of the vernacular would have been to provide all apartments with a private firewood or wood pellet stove, to give the quality of individual control and the presence of fire a large weight. However, taking the firewood stove back into the city is problematic on a larger scale, with connected health issues of smoke and added installations. We also questioned the need for individuality and self-sufficiency, when a sustainability aspect of the urban is sharing resources and infrastructure. Instead, we decided to focus on the spatial and comfort aspects of vernacular heating, and how that could be translated to an urban setting with the existing available infrastructure, resulting in a wall heating concept that utilizes the existing district heating merged with the qualities found in the vernacular.

Overall, there are many features of our proposal that are not found in the vernacular. For example, there is a car park - a feature alien to a vernacular typology. However, in a contemporary urban housing proposal, mobility cannot be ignored. The economization principles of the vernacular and the low-complexity aim of the low-tech approach has however been the inspiration behind the proposal to reduce parking into a shared car pool and generous bike rooms.

The contribution of this thesis is partly showing that in studying vernacular architecture with that times available tools and way of living in mind, much knowledge can be found with high relevance today. Basic sustainability questions such as economization of resources and relation to local context, are constantly present in the vernacular architecture. This thesis contributes with showing through research by design, an example of how sustainability principles from the vernacular could be translated into a low-tech contemporary design.

*How can low-tech architecture support well-being in a multi-family dwelling?*

In this thesis, we found the aspects of spatial dwelling qualities and comfort to go well in hand with a low-tech approach. For instance, working with a visible wooden structure and interior clay finishes, gives tactile and sensorial qualities to the dwelling, whilst creating a good indoor climate with low environmental impact materials. Unheated parts of the dwelling buffer heat losses, as well as prewarming inlet air and providing a place to expand living space depending on season. In our design concepts, we have almost always added a social layer, with sharing and neighbour interaction concepts. For instance, an access balcony is not only an economical solution for apartment access: placed in the south towards the yard, it also provides shading and a possible expansion of living space for the apartments and acts as the main social infrastructure of the block - a translation of a village street.

The contribution within this question is showing how the modern term of a building system can be double or triple programmed if made in a low-tech way. Instead of solely adding technical systems, this thesis sought to address comfort aspects with the architecture itself, through materiality that gives a comfortable indoor climate as well as spatial qualities and places for social interaction. With this approach, sustainable housing can be addressed in a long term and holistic way, connecting the dwellers to their home, their neighbours and place.

*How can architecture be formed by its local conditions and climate?*

As can be said about reinterpreting the vernacular, the urban location has given us different challenges compared to if we would have chosen a rural location. On a rural site, the project would have been more distinctively shaped by the local climate, while our urban location meant balancing climatic aspects such as orientation towards the sun, wind directions, building form and material properties with aspects of the existing urban fabric and form. We were however aware of these aspects in the choice of site, and the possibility for a north-south orientation and a protected yard towards the villas, was one of the reasons the site was chosen.

Still, some of our design choices were made where we had to choose between the local conditions of the site or climatic principles. For example, following a strict energy-conserving strategy for the building form would have given us a closed building block, but where we chose to prioritize the urban situation, making a more porous border between the areas and splitting up the block into several volumes. In general, basic guidelines were followed linked to the Gothenburg climate, as well as considerations on form, openings, material properties and orientation. Considering these aspects in an early stage can aid in avoiding compensating high-tech systems, and at the same time provide qualitative spaces for the dwellers.

The most important contribution within this question is however the idea to let the inhabitants be more involved and aware of the local climate, in being able to change their living space during different weather and seasons, and in this way relinking the climate to the everyday life of the dwellers.

## reflections

### *Design choices*

The choice of materials used in the design proposal was driven by the indoor climate regulating properties and environmental impact. The dowel laminated timber structure builds upon the tradition of log houses and utilizes properties found in the wood itself to join the elements. The larger dimensions needed in comparison to CLT, however raises the question of how to evaluate the avoiding of chemical additives in relation to minimizing the use of wood. Either way, future development of renewable construction methods should promote high quality wood to encourage a more sustainable forestry.

Studying options for providing fresh air, we were interested in finding a compromise between minimizing energy losses and using technology. We found the option of an energy use optimized AHU, as requiring more installations and maintenance, whilst completely unregulated natural ventilation as too energy consuming to be relevant today. The compromise of technically steered ventilation windows with stack effect exhaust, was chosen as an option that maintained user control, with minimal installations.

Choosing a flat roof with sedum cover, requires fossil-based materials today for waterproofing. A higher pitch could have allowed for materials with lower impact and it was considered during the design process. However, the building height towards the street as well as the high angle needed to avoid fossil based water proofing lead to the decision of proposing low pitch roofs with sedum cover. With this choice, reducing stormwater volume and rate on the urban surrounding and the social qualities of adding a roof terrace were qualities were prioritized in the design proposal.

### *The human factor*

In taking inspiration from vernacular principles for a contemporary design, there is a discussion to be made regarding the inhabitants then and now. In the vernacular context, economizing with resources was a way of survival, and making sure of survival also for the next year. Today, economization is an important strategy to reach the global sustainability goals, but is still considered a choice on an individual level, since there is always the opportunity to use more resources than you need. Today, although buildings can be designed in a low-tech way and give sustainability qualities in terms of material use and energy losses, it is within the assumption that the inhabitants will accept the design as it is intended to be

used. There is for example nothing stopping an inhabitant to remove the heat walls and buy an air heating device instead, or take the opportunity to expand your living space permanently by heating the winter garden or the access veranda.

However, our focus on well-being aspects within the low-tech approach, both based on spatial qualities and human comfort, aims to give the inhabitants more control and intuitive understanding compared to high-tech systems. We have chosen this approach since we believe that by designing with sensitivity to the inhabitants, the design is given more opportunities to be appropriated and to ensure a long-term relevance.

### *Process and method*

There are many ways to approach translating vernacular principles into a contemporary context, and we are aware that several master thesis projects could fit within this subject. Instead of focusing on a deeper investigation on a narrow aspect, this thesis took a holistic research by design approach. One of the problems of the building industry today that was identified in this thesis is complexity and fragmentation, as well as a lack of holistic thinking. Our reading of the low-tech approach is that site specificness is key, and we were interested in testing this approach in a west Swedish context. The research by design methodology helped us to approach the aim of this thesis, to develop a site-specific design where the composition of material and space in relation to the local situation and climate, can provide comfort and well-being for its inhabitants.

To verify design options and indoor climate qualities, this thesis had the initial ambition to use energy calculations and simulations parallel to the design iterations. This was delimited in the process and climatic principles found in literature and in the reference studies were instead chosen. Collaborating with an engineer and performing elaborated calculations, could have led to interesting reiterations and design choices in a continued work.

Working physically with models throughout the process was a helpful tool for us to both understand the context and to study design choices. Using model photos as the main method of representation, we hope the proposal can convey a sense of how low-tech architecture can support well-being, through its spatial and material qualities.

## references

### Literature

- Bokalders, V., Block, M. (2010). *The Whole building handbook*. Sterling.
- Hansen, A., Nordström, K. (2007). *Gårdar kring Göteborg: En bebyggelsehistorisk överblick*. Göteborgs stadsmuseum.
- Hill, J. (2012). *Weather architecture*. Routledge.
- Heiselberg, P. (2004). *Natural ventilation design*. Taylor & Francis.
- Lundgren, M. (2019). *Performance in the Sweden Building Code*. Licentiate thesis, KTH.
- Lönnroth, G. (1999). *Kulturbistoriskt värdefull bebyggelse i göteborg: ett program för bevarande: del i*. Stadsmuseet, Göteborg.
- Morichetto, H. (2019). *Bostadens arkitektur och berikad miljö*. Licentiate thesis, Chalmers University of Technology.
- Nylander, O. (2018). *Svensk Bostadsarkitektur: Utveckling från 1800-tal till 2000-tal*. Studentlitteratur.
- Rosenlund, H. (2001). *Climatic design of buildings using passive techniques*. HDM, Lund University.
- Sternberg, E. M., Wilson, M. A. (2006). *Neuroscience and Architecture: Seeking Common Ground*. Cell.

### Web sources

- Dictionary.com (2021). *Well-being definition*. Retrieved from <https://www.dictionary.com/browse/wellbeing>
- Dictionary.com (2021). *Weather definition*. <https://www.dictionary.com/browse/weather>
- Slöjd och byggnadsvård (2021). *Solåsen 1840*. Retrieved from <https://www.slojdochbyggnadsvard.se/kunskap-och-fakta/hus-i-vast/solasen/konstruktion/>

SMHI (2021). *Climate definition*. Retrieved from <https://www.smhi.se/kunskapsbanken/klimat>

### Reports and data

- Eniro (2021). *Residents and property area in Johanneberg*. Retrieved from <https://kartor.eniro.se/?c=57.716985,12.045822&cz=12>
- Göteborgs stad. (2021). *Noise data*. Retrieved from <https://karta.miljoforvaltningen.goteborg.se/>
- Harvard t.h. Chan, (2019). *Homes for health*. Harvard, School of public health.
- Norsk Treteknisk Institutt. (2016). *Building materials and well-being in indoor environments*. Norsk Treteknisk Institutt.
- SGU. (2021). *Geologikartan*. Retrieved from <https://apps.sgu.se/geokartan/#mappage>
- SMHI. (2021). *Västergötlands klimat*. Retrieved from: <https://www.smhi.se/kunskapsbanken/klimat/klimatet-i-sveriges-landskap/vastergotlands-klimat-1.4902>
- SMHI. (2021). *Weather data: Gamlestaden, Landvetter, Gothenburg*. Retrieved from <https://www.smhi.se/data/meteorologi/ladda-ner-meteorologiska-observationer#param=airtemperatureInstant,stations=all>

### Figures

Unless otherwise stated, figures and images belong to the authors.

Figure 1. Falbygden museum. (2018). *Vernacular Swedish Ryggåsstuga*. Retrieved from <https://digitaltmuseum.se/021017766036/ryggasstuga-pa-tan>

Figure 2. Rosenlund, H. (2001). *Climatic design of buildings using passive techniques*. HDM, Lund University.

Figure 3. Gösta Nordins arkiv. (2021). *Construction of Hallonbergen, Sundbyberg*. Retrieved from <https://www.allmannyttan.se/historia/historiska-epoker/1946-1975-allmannyttan-byggs-ut-och-bostadsbristen-byggs-bort/>

Figure 4. Bertini, V. (2010). *New barrid Village*. Retrieved from <https://www.wallpaper.com/architecture/hassan-fathy-book-laurence-king>

Figure 5. Murcott, G. (1994). *Marika-Alderton house*. Retrieved from <https://www.thoughtco.com/marika-alderton-house-178004>

Figure 6. Ruault, P. (2018). *Maison Latapie*. Retrieved from <https://www.atlasofplaces.com/architecture/maison-latapie/>

Figure 7. Hueber, E. (2013). *2226 office building*. Retrieved from <https://www.archdaily.com/451653/2226-be-baumschlagel-eberle>

Figure 8. Vänersborgs museum. (2014). *Cottage with an elevated position in the landscape*. CC BY-SA. Retrieved from <https://digitalmuseum.se/021015596961/ryggasstuga-holm>

Figure 9. Franzén, A. (2018). *Horisontal timber structure with granite stove*. Retrieved from <https://digitalmuseum.se/021018410392/interior-fran-ryggasstugan-i-appladalen-varnamo-kommun>

Figure 10. Björnånger, E. (2015). *Wooden cladding to protect the timber structure*. CC BY-SA. Retrieved from <https://digitalmuseum.se/021015800496/herrljunga-framkamarstuga>

Figure 11. Slöjd och byggnadsvård. (2021). *Interior clay finish for air-tightness*. Retrieved from <https://www.slojdochbyggnadsvard.se/kunskap-och-fakta/hus-i-vast/helgerod---dubbelhus-1900/KonstruktionHelgerod/>

Figure 12. Slöjd och byggnadsvård. (2021). *Raised granite foundation*. Retrieved from <https://www.slojdochbyggnadsvard.se/kunskap-och-fakta/hus-i-vast/helgerod---dubbelhus-1900/KonstruktionHelgerod/>

Figure 13. Slöjd och byggnadsvård. (2021). *Singel glazed window with interior winter pane*. Retrieved from <https://www.slojdochbyggnadsvard.se/kunskap-och-fakta/hus-i-vast/helgerod---dubbelhus-1900/KonstruktionHelgerod/>

Figure 14. Liljeroth, E. (2014). *Farming in front of a Framkamarstuga*. CC BY-NC-ND. Retrieved from <https://digitalmuseum.se/011013837075/framkamarstuga-i-marserum>.

Figure 15. Hansen, A., Nordström, K. (2007). *Gårdar kring Göteborg: En bebyggelsehistorisk överblick*.

Figure 16. Västmanlands museum. (2018). *Traditional timber wall with internal wooden dowels*. Retrieved from <https://digitalmuseum.org/021017958388/gunnilbo-sn-gillbo>

Figure 17. Spoerri, N. (2014). *Haus J, Zurich*. Retrieved from <https://www.poolarch.ch/projekte/2009/0243-maw-haus-j/&refPage=Projektstand&filter=Wettbewerbe&browse=browse>



**CHALMERS**  
UNIVERSITY OF TECHNOLOGY

© Elin Lidén & Martin Lindholm  
Master thesis spring 2021

Chalmers School of Architecture  
Department of Architecture and Civil Engineering  
Architecture and Planning Beyond Sustainability