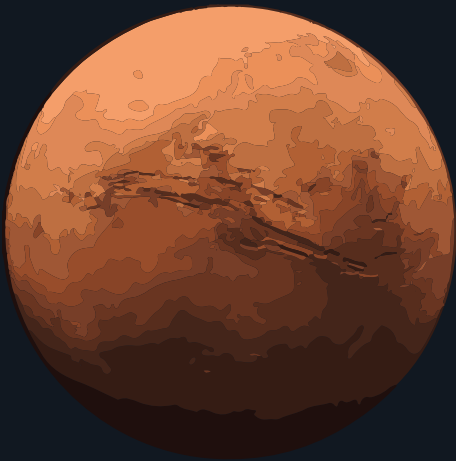


# THE RED DOT.

## Exploring 3D printing a habitat on Mars

Adrian Pihl Spahiu  
Department for Architecture and Civil Engineering  
Chalmers University of Technology  
Examiner: Jonas Lundberg  
Supervisor: Kengo Skorick





**CHALMERS**  
UNIVERSITY OF TECHNOLOGY

Adrian Pihl Spahiu  
Master Thesis Spring 2020  
Examiner: Jonas Lundberg  
Supervisors: Kengo Skorick

Chalmers School of Architecture  
Department of Architecture and Civil Engineering  
Gothenburg, Sweden

# ABSTRACT

This thesis presents a concept for the first human habitat on Mars by investigating different possibilities of 3D printing with Martian regolith. It has approached this by designing iteratively and expanding the level of detail with each iteration. Through this process knowledge has been gained to answer the research questions.

The thesis proposes a concept of what to build and how to build it by setting up rules and investigating the design options allowed within these rules. By doing so the thesis answers the questions to what a specific printer can print, how different methods of printing affect architecture and how printed architecture will combine with prefabricated parts from Earth.

It also proposes ways of integrating technical solutions with the architecture to make them a part of the design rather than additions to the design.

The thesis has added new ideas to and expanded the discourse on additive manufacturing using on site resources on Mars and explored what options are available to a specific type of 3D printer, and how to print to achieve goals of structural stability, volume and useful space.

This design has then been adapted into a design language that can be adapted for use on different sites with different conditions allowing future expansion on this work.

One of these potential conditions has been explored further, examining what consequences the design rules have on tactility, spatial structures, functions and details.

This has resulted in a proposed Mars Habitat for the first humans to set foot on Mars. The design has been explored from general volumes available to be printed to how

installations and infrastructure are designed to allow them to be built by the 3D printer while still allowing for flexibility once the humans land on Mars.

Each iteration giving an answer to the question of what effects previous design choices are expected to have in further detail.

The final concept is presented as a short novel depicting the life in the habitat for the astronauts, as well as illustrations and plans for the habitat. The short novel also aims to contribute to an understanding of how people living in the habitat could experience the architecture and what life inside the habitat could look like.

**Keywords:** *Additive manufacturing, Martian regolith, On site resource utilization, Architecture Fiction, Extraterrestrial habitation*

## **ADRIAN PIHL SPAHIU**

### *Master program in Architecture*

*Chalmers University of Technology 2018-2020*

Material Turn (Thesis) 2020

Matter Space Structure 3 2019

Spatial Morphology 2019

Matter Space Structure 1 2018

### *Internship*

Bonava In House Design 2017-2018

### *Bachelor program in Architecture*

*Chalmers University of Technology 2014-2017*

### *Contact*

Phone: +46 735 03 07 07

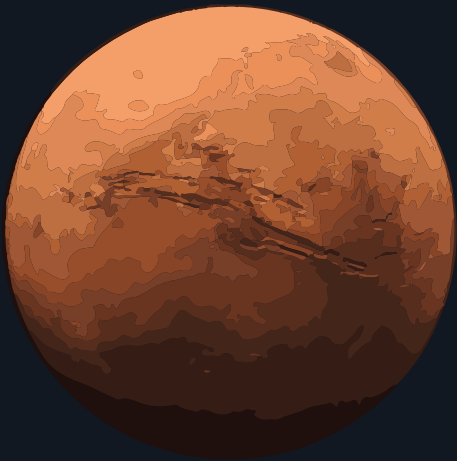
Email: [adrian@pihlspahiu.se](mailto:adrian@pihlspahiu.se)

# INDEX

<b>THE NEXT SMALL STEP</b>	<b>7</b>
Arrival	8
Inspection	10
Making a home	12
A Change in pace	14
<b>INTRODUCTION</b>	<b>17</b>
Purpose, aim and research question	18
Context	19
Method	20
Delimitations	21
Planetary comparison	22
Historical references	24
<b>THE HABITAT</b>	<b>27</b>
Elevation	30
Cutout	32
Plans	34
Laboratory	36
Common Room	38
Workshop	40
Constructing the habitat	42
Installing greenhouse top	44
Installing windows and doors	45
<b>DESIGN PROCESS</b>	<b>47</b>
Printable area	48
Methods of printing	50
Shaping the habitat	52
Handling elevation	54
Material and effects of printing methods	58
Printing paths	62
Rooms and functions	65
Stairs	68
Windows and Openings	69
Vertical garden	70
Results	72
Early sketches	73
<b>REFERENCES AND ACKNOWLEDGEMENTS</b>	<b>75</b>
Acknowledgements	76
Inspirational references	77
Image references	78
References	79



THE NEXT SMALL STEP



# ARRIVAL

It was with sense of suppressed excitement that Dylan watched Amanda Archer open the hatch. Sunlight shone into the airlock and he could hear his commander say a few well-prepared words. It felt almost strange to address the world as if it looked on while they took their historic steps. Many people would watch this of course, but with the vast distance between Mars and Earth, the audience wouldn't see this footage in roughly another ten minutes.

It was funny how that final step always seemed to be centre of attention, when in fact it was most likely the easiest part of the entire expedition. They were already historic as the first humans to leave Earth's sphere of influence over half a year ago. They had managed to hit the atmosphere of Mars with just the right angle to do an aerobrake without impacting the planet or missing it all together. They had established a stable orbit around the planet and considering how many probes that had failed to do just that in the past this alone was a feat not to be diminished.

From this orbit they had pinpointed the landing site of the automated robots and equipment that had been sent beforehand, and then landed right next to it themselves. They were on another planet, within five hundred meters of equipment sent here on a completely different rocket, years ago. And still. It was that final step that got all the attention. Just like Neil Armstrong had been before, it was Amanda Archer who would forever be remembered as the first human on Mars. She was the one destined to take that single step that touched the red planet's surface. They had left Earth eight months ago and they would stay on Mars for more than year before going back, but the coming 30 seconds was what they would be forever known for.

Once Amanda was out on the ground it was time for the rest of the crew. Dylan was the third one out. At the hatch he took a second to observe the barren landscape they had travelled so long to reach, and then he climbed down the ladder to the surface.

The thin dust almost made the surface slippery when walking on it, and though they were well aware of that the fine grains of the Martian dust would be unlike anything they had experienced on Earth, the knowledge didn't stop the experience from being a bit awkward.

As the construction engineer of this mission it was Dylan's job to make sure that their prefabricated habitat got ready to move into, and that job didn't wait for sentimentality. After all, they were not tour-

ists here to enjoy the sights. The sooner they could manage to move into their small outpost the better.

The first thing Dylan did was to locate the test arch built by the printer. He put up a few seismographs and other sensors and started drilling in the arc. They wanted to make sure that the printer they had sent beforehand had managed to get the right composition of the regolith mixture when the habitat was printed. Assuming these measurements indicated that the structure was stable, they would proceed to the actual habitat and do more thorough tests there.

Once the stability of the structure was assured, they would move fixtures like windows and doors into place. The windows had inflatable frames and would be placed in the openings of the printed volume and then inflated to seal the opening. The openings in the habitat had these prepared indentations where the inflatable frames of doors and windows would fit.

At this time Dylan's two main concerns were if the polyactic acid and regolith mixture would be able to contain an earthlike atmosphere inside, and how the prefabricated parts brought from earth would fit with the in situ-built parts. They had of course tested all of this on Earth, but no previous sample return missions had brought back enough material to do any tests with actual Martian regolith, so all their tests had been made with materials believed to have similar properties.

With all tests that had to be made in the habitat before they could move in, they would likely have to live in the lander module for a few more days. At least now they had some gravity, and could leave the cramped spaceship, but it would be nice to move into their more permanent habitat. Of course, it wouldn't only be their home. It would be humanity's home on Mars. Assuming all went according to plan, they would be replaced by another expedition next year, and the base would be expanded upon. In many ways, this habitat was much like Scott's Discovery hut on Antarctica. It was built during the "Discovery expedition" around 1903, and was still standing with the McMurdo station in the background.

Before installing anything however, Dylan needed to inspect the structure that had been built before their arrival.

A printing robot had been sent in advance and had during the last two years been excavating the site and building the base. The lander that had been

sent beforehand had come with a robotic arm and a powerplant. The arm was designed based on the Canada-arm that had been used on the International Space Station for many years. The arm had a connector in both ends and by installing different docking ports it could move around.

From its position on top of the lander module it had printed a stand for one of the docking ports in the middle of what would become the habitat. From there it had first scanned the surroundings, making a map of the elevation around it. The printer had a preprogrammed script that dictated how it would print the foundation based on the terrain. The foundation had been printed so that it was level with the lander module, and then the arm started printing the actual habitat around itself. Some equipment and gear were included in the lander module and had been lifted into place as the printer printed the habitat.

On top of the roof of the habitat another stand for a docking port had been printed, and installed. Once the shape of the habitat was completed, the arm would move to the top of the roof and lift the greenhouse roof into place above where the printer had previously stood while printing. It was a large waterfilled structure. Water was an immensely important resource for this expedition. Not only is it a necessity to sustain life, but it was also a good material to use for shielding against radiation.

The magnetic field of Mars was quite weak compared to the one on earth and the astronauts would be exposed to a lot more radiation from the sun and cosmic background than on earth, and the water protect them from it while inside the habitat.

Once the waterfilled dome was put in place the arm would move back to its initial position on top of the lander module. There it would act as a crane lifting materials and helping the astronauts once on site.

The foundation of the habitat was printed as small channels going in circles around the centre, and one channel going straight inside. This channel could be used to reach the other channels. Dylan located the opening. Before going inside the habitat Dylan needed to make sure that the foundation had been printed properly. He turned on his suits built-in LED headlights and carefully walked through the channels in the foundation, four of them spanning a distance of over 200 meters combined, looking for flaws in the print. Some parts were so narrow that he couldn't inspect them himself and instead he had to

use a camera to inspect remotely.

It took Dylan the better part of a day to inspect the entire foundation but when the crew started finishing for the day, he had concluded that the foundation of the habitat was stable. The crew retreated to the spacecraft that they had arrived in, had dinner and went to bed.

The next day the crew prepared to enter the habitat. The lander module that had carried the arm that printed the habitat had two functions. Partly as a transportation vessel for the arm and much of the gear that was to be installed, but also as an airlock used for going in and out of the habitat. The module had one hatch for astronauts, one dock where you could connect a vehicle, and a hatch in the roof where heavier gear could be lifted in using the printing arm.

The airlock also had a hatch leading into the habitat. In case of an incident where the habitat lost atmosphere, the airlock would act as a shelter while the crew tried to repair the damages.

Once in the airlock the crew pressurised the airlock to test it. It had been tested rigorously on earth of course, but that was before standing in the Martian dust for a year. Specially the ceiling hatch where the arm had lifted out equipment had been open for a long time and they had to see if the hatch would still seal correctly. After some testing, they felt confident that the airlock was securely sealed and depressurised it again. Then they opened the door into the habitat.

# INSPECTION

As the structural engineer it was Dylan's job to secure the habitat was structurally safe, and as such it was only natural that he was the one to take the first steps into their future home. The hallway in front of them was dark, only lit by the light from the airlock behind them and the windows in the adjacent rooms. Dylan turned on the LED lights in his suit and proceeded inside. Carefully he walked forward, inspecting the printed layers. The floor was a bit uneven due to how the printer functioned but in time they would fix that. They had a portable printing extruder with a much smaller nozzle that they could use for filling in potential gaps, as well as a portable mill. Dylan's plan was to use these tools to make corrections and adjustments to the main structure. But first they had to make sure the habitat structure was stable and ready for them.

To his right, the first room was the medical bay. Light shone in through the narrow window in the other end of the room. He looked up at the ceiling. It made him feel almost as if in a crevasse. The curved walls of the habitat were much closer to him than the ceiling. The 3D printer cannot print overhangs very well and instead the walls arced into each other to support the level above, making the room feel almost like a small cathedral. In fact, it had been referred to as 'The Temple of human exploration' back on earth when they were planning the mission.

Dylan stared up at the ceiling with a profound feeling of reverence. They were here. On Mars. In what would be humanity's first home on the planet. He was abruptly reminded of his duties however, when he heard the commander crackling in his headset.

- How are we coming along Dylan?
- The print is a bit uneven at places, we will have to fill that in with the portable extruders, but so far nothing that is outside of the allowed range.
- Good. When can we start unpacking?
- You can start moving the equipment graded for low pressure environments into the medical bay.
- Good. Laura, do you copy?
- Yes. I'll bring the first things over.

Laura was the physician of the crew. All in all, they were six astronauts on this mission. Aside from Amanda, Dylan and Laura, they also had David, a physicist, Eric, an engineer, and Anna, a chemist. Most of them had more than one specialty. Dylan himself for example had his main function as a structural engineer but was also trained as pilot back during his military service. He was trained to fly their lander should the automated program malfunction.

It was a tricky situation for the entire mission. They could only send a limited number of people on the mission and the need for expertise far outnumbered the number of seats in their vessel. Therefore, the crew had been selected to include an as wide selection of expertise as possible, and all of them had a function related to research, and one to actually surviving on Mars. In many cases they overlapped. Anna for example would test the material composition of various samples of the Martian surface but was also responsible for the machines extracting oxygen from the Martian atmosphere and excavating water.

It was of course impossible to prepare for all the different complications that could occur, but they had done their best to cover as many known unknowns as possible. It was more likely that they would encounter problems with the 'unknown unknowns'. Problems that you didn't know could even become problems.

While Laura started lifting boxes into the medical bay Dylan walked further into the habitat. After the medical bay the next room to his right was the 'bathroom'. It wasn't much of a bathroom right now, but once they had managed to install the infrastructure and pressurised the habitat, they would retrofit the toilet they had brought on the lander and install it here. Assuming they were able to extract enough water they also had brought blueprints for printing a shower head but that was future project.

After the bathroom came three identical bedrooms. The frame for the bed was printed along with the rest of the habitat before their arrival. Due to the low gravity on Mars they wouldn't need a very thick mattress to sleep comfortable. The bed as well as the walls had indentations in the print where light fixtures would be installed. Each bedroom also had a small window leading out to the central greenhouse. Dylan took a few steps close to the opening and looked out into the atrium in the middle of the habitat. Above him were several terraces that would be filled with an artificial soil created by mixing Martian regolith with bio-waste.

Bio-waste was a nice way of putting it Dylan remarked to himself. In reality it was their urine and faeces collected during their trip to reach Mars. Space exploration is generally – rightfully so – seen as the cutting edge of technology, but people often forget what happens when you put six people in a small space together for several months. And the exploration of Mars was no exception. Hu-

man spaceflight has always had the same problem. There's limited water, it's closed environment and there's no good place to throw your garbage. When the Apollo programme took humans to the moon they had worn diapers as there were no toilets on the small Apollo command module. While the Space Shuttle and the International Space Station had toilets, it's not like they are venting it into space. And they still have a limited amount of water. Which is recycled. Being an astronaut is hardly for the germophobes.

They would start filling the lower levels as soon as the habitat was pressurised, and then as they collected more and more bio-waste, would expand their farms further and further up. In the middle, where the printer arm had been installed while printing the habitat, a smaller arm would be placed. This smaller arm would be able to allow the crew to reach the terraces and harvest the crops. They had brought enough food for their journey, but for the long-term sustainability in keeping a human presence on Mars, they would need to produce their own food.

Past the three bedrooms were the kitchen area and the common room. The printer arm had lifted several of the appliances for the kitchen into place already, but the common room was rather empty. There were windows out into the greenhouse from the common room too. Two large opening between the kitchen and common room allowed for movement between the two chambers.

Dylan took a pause and looked at his information panel at the wrist. He had already spent four hours inspecting the habitat. A part of him wanted to continue inspecting but he also knew that his excitement was likely to mask an exhaustion that would potentially lead to mistakes being made. He decided to take a break for lunch. He marked how far he had come during his examination and gathered his gear before leaving for the airlock. At the airlock he converged with Amanda and Laura who had been unpacking in the medical bay. Together they all left the habitat and walked over to the lander where the rest of the crew were working.

After lunch Dylan went back into the habitat and continued inspecting the three bedrooms on the other side of the kitchen and common room. At the entrance to the last bedroom Dylan could see the underside of the stairs leading to the second level. There was a narrow corridor leading around the stairs. Once past the stairs he was back at the medical bay. Through the medical bay he would be back at the airlock. He radioed in to update the rest

of the crew and headed up the stairs.

The stairs were designed much like a regular staircase back on Earth. They had tested different ways of traversing between the levels but in the end, the results had shown that the most limiting factor wasn't gravity, but rather the human body. Even though the physical strain of traversing up and down the stairs was lower, the human body still had the same functions. So, in the end, they had decided upon using a stair similar to what they were all used to back on earth. Walking in it was still somewhat hard, however. Specially walking down would feel awkward Dylan knew from his stay at the moon.

When he reached the top of the stairs, he could see the lab in front of him. Some equipment had been lifted into the lab already, but they would have to install it manually. The shape of the habitat wouldn't allow the arm to keep printing after they were put in place, so instead the crew would have to manually place the equipment.

In the ground, above the central wall that separated the chambers on level one from each other, was the ventilation duct going in a circle around the entire habitat. The life support system was installed in the airlock and distributed breathable air through the habitat via the ventilation channel. Right now it was like a dug trench throughout the second level, but they would put panels on top of it.

Behind him he had a large storage room for experiments and materials. Dylan continued through the lab and reached the workshop. This was where they would print the items they hadn't brought with them. They would also perform other types of construction there of course.

Through the workshop Dylan ended up in the large storage area that was behind the stairs leading up. The second level was a bit smaller than the first level, it only had one chamber, and it felt smaller as well as the rooms were more open and only had a few functions. When Dylan was back at the stairs he stretched himself a bit. It had been a long day, but now it was done. He radioed to the rest of the crew.

- Initial inspection is completed. The habitat is cleared for fixture installations.

## MAKING A HOME

After the initial inspection the rest of the crew had been eager to start installing themselves in the habitat. The lander had never been intended for living in permanently and it lacked some commodities that they even had back during the voyage to get to Mars. Once down on the surface where they had gravity, parts of the lander were unusable. In addition to this, they had left half of their ship in orbit around Mars, waiting for them to return when going back to Earth in two years. It was much more energy efficient that way. The Apollo missions to the moon had been carried out the same way. Considering the enormous forces used in space travel, just bringing fuel for the next leg of the trip forced you to start with a lot more fuel. Having to land the spaceship that would take them back to earth on Mars, and then launch it into orbit again would require too much energy to be justifiable so instead they left it in orbit, only landing with a ship large enough to fill their absolute needs, and only fuel to get them back into orbit, not back to earth.

And as such, the living condition in the lander were spartan to say the least.

The day after the inspection they had started installing the windows inside the habitat. Studies showed that being able to see greenery during the stay would benefit the psychological health for the crew. It was also known that being in a closed environment for a long time could affect the far sight of humans, so giving the astronauts some sort of vista was seen as a good idea. However, the greenhouse would also be pressurised, and bringing windows added a lot of weight to the mission. In the end, the argument of redundancy had been swung the general opinion into bringing the windows. Should something happen to the greenhouse and it lost pressure, the rest of the habitat would still be safe. Another factor was that they would be able to depressurise the greenhouse and remove the water filled dome without that operation affecting the living areas of the habitat.

Once the windows were in place they would pressurise the habitat. Even though the habitat was pressurised with a breathing atmosphere they would initially stay in their EVA suits. They had to have the habitat pressurised for 24 hours without losing air pressure before it would be considered safe to start working without the suits. The same procedure had to be repeated for the greenhouse as well, but that wouldn't affect them as much as they were not actively working in the greenhouse yet.

To ensure correct readings nobody was allowed in

or out of the habitat during the tests, but in order to get a full day's work out of the day the crew started installing infrastructure and equipment before starting the check. David and Anna were moving the equipment in the lab into place while Eric was installing the electrical and water infrastructure. Channels had been left unprinted by the 3D printer at places, and the cables would be installed in these channels. When installed they would be integrated into the structure of the habitat but also be easily removed and maintained.

Laura was moving boxes of medical supplies into the medical bay; Amanda was working outside the habitat with the connections to external functions. There was a high capacity communications tower that would be installed on a hill near the habitat, and electricity was also generated outside of the habitat. Dylan used this time to install the lights in the indentations that had been left in the walls in the rooms.

When the crew gathered to move back into the lander module Dylan stopped them outside the airlock. He pressed a few buttons on the display on his wrist and the hallway lit up. It was the first time they could see the habitat as it would be when living in it.

- In 24 hours, this could be home if all goes as planned, he remarked.

The next day the crew returned to the habitat to check the pressure readings. This was the moment Dylan had dreaded the most. There had been no way to pressure test a habitat built with Martian regolith. The only tests that had been made were with materials manufactured on Earth, made to resemble Martian regolith. If this mixture was too different from the test mixture the material could be porous and unable to contain an atmosphere. That would of course be an enormous blow for not only their mission, but the future exploration of Mars.

But so far everything looked good. The pressure inside the habitat hadn't dropped during the night and soon the 24-hour period had passed. If this held, they could finally move into the habitat.

In order not to disturb the readings they had decided not to enter the habitat until pressure check was all clear. Instead they started preparing the equipment in the lander for being moved over to the habitat. The heavier supplies and equipment they placed outside the airlock. The arm would lift it into the airlock later, so they wouldn't have to struggle with fitting it through the hatch.

When the long wait was finally over Dylan took a look at his wrist panel. No pressure drop. The habitat was cleared for living in. A weight dropped from Dylan's shoulders and relieved he radioed the rest of the crew.

- The 24-hour readings are in. The habitat is cleared for moving in.

Excited the crew entered the habitat. When the airlock was pressurised they removed their EVA suits. The floor of the habitat was still a bit uneven, so for now they would use boots to not stumble or get their toes stuck in the gaps between the paths the printer had printed. Dylan almost held his breath when they opened the hatch into the habitat, almost expecting they be greeted by the thin Martian atmosphere. But that didn't happen. Only a slightly cold draft came from the dark corridors.

They stepped into the habitat and started unpacking. When night came Dylan had the best night's sleep in a long time. He was in his own bedroom, and the habitat he had helped design was working. It had held. They were living in it. On Mars.

From that moment on, their lives turned into more regular lives and soon the initial days in the cramped lander seemed like a distant memory. A few days after moving into the habitat the greenhouse had been cleared for use, and Anna had started mixing soil and planting crops. Dylan had used the portable extruder and mill to even out the floor around the habitat to make it more walkable. The crew had started with their research, and in the workshop, tools had been made. Not only tools, all sort of things. They had constructed the chairs used in the communal room in the workshop, and they had moved a TV screen into the communal room as well.

In the evenings they had movie nights in there. The distance to Earth wouldn't exactly allow them to surf the internet, but the bandwidth of the communications network allowed for much data to be transferred in both directions. That mean they could send back tons of research data, but also that they would be able to receive large files themselves. So they had a steady supply of films and shows to watch during their free time, and requests could be sent in to see something of particular interest. As they didn't have the chance to base their reading on headlines or following links in websites, they had instead opted to make list of newspapers or news sites they wanted to follow, and they would be sent from Earth in their entirety for the crew to read or watch.

For Dylan, one of the things he subscribed to, was the games of his football team. He would follow the games of his hometown team when he had some time over. As this wasn't an interest he shared with the rest of the crew, he would often take the time to watch the games late in the evenings when the rest of them had gone to bed.

But even though life on Mars started to resemble their previous lives on Earth more and more, there was always the constant reminder of that they were on a planet far from Earth. A planet that for several reason had no indigenous life. At least not that had survived.

A couple of months into their stay the got the signal they had all expected to come sooner or later. A solar flare was headed for them. It was a rather common phenomenon but back on Earth the magnetic field was shielding the life on the planet from danger. Here on Mars, the magnetic field was too weak to protect them. Instead they would have to rely on the habitat. This was one of the reasons the outer walls were filled with water as water shielded against radiation. But for the crew to remain as safe as possible they were all assigned to their bedrooms. The bedrooms were at the heart of the habitat and had the most matter shielding them from the dangerous radiation. In addition to the water in the walls, there was the second level with all the equipment and also the floor between the levels to shield them. The greenhouse had a glass dome covering the top, and from the greenhouse there was another wall before any radiation would reach the bedrooms.

While the bedrooms were the safest place for them during the bombardment of the solar flare, being confined to the bedroom for a day made them restless. Dylan took the time to catch up on writing some reports and sketch on potential improvements to the habitat that he would propose for the next crew to live there.

## A CHANGE IN PACE

With the months passing improvements were made to the habitat every day. They had managed to improve the capacity of the water processing unit allowing for larger volumes to be processed every day. This meant that they could install the shower head that they had planned into the bathroom. While they still lacked amenities like soap, just being able to wash your body under running water was a comfort they had missed for a long time.

They also got the chance to test their own grown plants. The selection of plants had been chosen in an attempt to allow for a wide variety of nutrition while still effective in their energy content compared to the area and water required to grow them. Their stock of crops included rice, wheat, sweet potatoes, peanuts, soybeans, pinto beans, winter squash, beet root, bananas and papaya.

The soybeans had been the first to be ready for harvest and was already a regular part of their daily diet, but there was a risk that they would never even be able to taste the Martian grown bananas and papayas before having to leave the surface.

One evening only a few days before the crew coming to replace them were about to land, Dylan went through the list of improvements they had made during their stay at the habitat. And it was an extensive list. Of course, that had always been the nature of their mission. Establish a base of operations on Mars. While they had conducted a lot of science experiments as well of course, the aim of those experiments was always in the end to improve life on Mars for future missions.

A lot of their daily tasks the first half of their stay had been to learn what they could do on their own, and what future missions would need to bring. There were three levels of categorizing the planned improvements. The first one, the most desirable one, was that they would be able to do it with what they already had on site. On this list they had things such as internal modifications to the habitat. They had handheld extruders and mills and would be able to complete modifications on their own if needed.

The second level was things they would be able to do mostly on site, but that needed some new supplies. One such example was to expand the habitat. They still had the arm that would do most of the work, but they would need new docking ports in order to move the arm around. But the docking ports were relatively small and didn't weigh as much as the arm, so future crews would be able to bring them. Another example was their garden. They

could expand it to lessen the need of supplies from Earth, but that would need a new dome, and if they wanted more variety in the crops, new seeds.

Third level was things that they would have to bring from Earth all together. One such thing was already on its way. 'The MEV' as it was often called. It was short for 'Martian Excursion Vehicle.' The second crew would bring it with them. It was a large vehicle that could support an atmosphere, had sleeping space for two persons, an airlock and the ability to go for expeditions lasting up to two weeks. It had always been planned to come with the second crew. It would allow them to explore the planet further away from the habitat. The rover would connect to the habitat's airlock allowing crew to move in and out of the rover without using EVA suits. The internal airlock also allowed the MEV's crew to leave the vehicle to explore the planet.

Dylan couldn't help but feel a bit envious of the second crew, who would be able to explore the planet in a way that his crew had never been able to. They would start off with commodities like running water in the shower, things his crew had to work hard to achieve. Then again, the second crew probably envied them for being the first ones to set a foot on Mars. And back on Earth, a lot of people envied both crews for being chosen to go to Mars.

There would be a period of overlapping when both crews would live in the habitat. This was due to that the trip between the planets could only be started during certain times, called transfer windows, and the transfer window going to Mars didn't exactly coincide with the transfer to Earth. So, they would have to live together for a while. The habitat was large and there was space for all of them to work, but there were only individual bedrooms for one crew. The replacement crew would spend the overlap in the two landers and the MEV, while the leaving crew got to stay in their own rooms until leaving.

A lot of focus would be on handing the habitat over to the new crew, allowing them to familiarise themselves with how things worked, what experiments were underway and what had been completed. However, the composition of the crew would change a bit with the focus shifting from establishing a base to exploring the planet. This meant that instead of a structural engineer the next crew had a geologist on board. Dylan did his best to fill in the new crew of the ins and outs of the habitat, but in many ways his mission on Mars was over. So, he took the time to help the others in their work. One day he took the opportunity to see more of Mars

by joining the geologist Richard on an expedition of two days in the MEV.

They would collect ground samples from other regions of Mars and bring them back to the lab for analysis. Dylan's crew would probably bring some back to Earth as well, where they would be tested with equipment they lacked on Mars.

Richard wanted to take samples from one of the impact craters, so they got into their suits and exited the MEV. The ground was rockier than back at the landing site, and to Dylan it seemed more brittle, almost cracking under the weight of their feet. Ahead of him he could see one stone under Richard break off. Richard fell down and hit his knee on the sharp edge of the rock.

Dylan heard him grunt out a curse. Dylan carefully moved over, carefully as to not copy Richard. When he reached the geologist he could see that there was a tear in the EVA suit at Richards right knee. He was venting atmosphere. Dylan reached for the emergency kit in one of his pockets. He covered the tear in a band aid and then sprayed a quick fastening sealant on top of it. He looked at Richards arm display. He was no longer leaking atmosphere. That was a good start.

Dylan helped Richard back on his feet and carefully helped him back to the MEV. Once in there he helped Richard out of the suit and inspected the knee. It was quite swollen. Dylan left Richard in the bed to rest and sat in the driver's seat. He radioed the habitat informing them of their accident and telling them to prepare the medical bay.

Back at the habitat Dylan docked the MEV to the airlock and with the help of the rest of the crew they carried Richard to the medical bay. Richard insisted that he could walk on his own, but they didn't want to risk making any injuries worse until they knew how bad it was.

Both Laura and the physician of the second crew, Joel, examined Richard and consulted with experts back on earth. The assessment was that Richard had been relatively lucky. They couldn't detect any fractures, but the impact had resulted in some internal bleeding that had swollen the area around the knee up. But Richard should be back in full condition in a few weeks. In the meantime he would have to conduct his research from the habitat.

Around the time Richard was back on his feet came the transfer window back to earth. The first crew

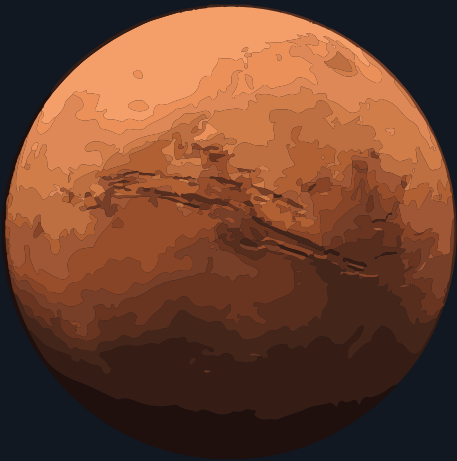
would pack up into their lander and reunite with the rocket taking them back to earth that they had left in orbit. As they carried the last things to bring back into the lander Dylan took one last look at the habitat. It had been their home for the most exciting year of his life, and now he would leave it behind. Likely never to return. With a melancholic pride he entered the lander to start his long voyage back to Earth.

*This work of fiction describes the life in the habitat proposed in this thesis. It is intended to support further exploration of the habitat beyond plans and illustrations. An exploration beyond the technical, into the experienced and lived.*

*The work has been used both as a design tool and as a tool of representation. Both large and small ideas and alterations to the habitat sprung from the process of writing the story.*



# INTRODUCTION



## PURPOSE, AIM AND RESEARCH QUESTION

The purpose of this thesis is to present an architectural concept for a Martian habitat that the first humans going to Mars will live in.

The aim is to propose a concept that is grounded enough in reality to be achievable while still being visionary enough to contribute to future ideas on how to build habitats on Mars.

The research questions are:

- What structures can a specific 3D printer build?
- How could the printing methods affect the architecture?
- How will the printed architecture combine with prefabricated parts from Earth?
- How could the people living in the habitat experience the architecture?
- What could life inside the habitat look like?
- How will the architecture fill the technical needs of a manned mission to Mars?

*"In the world of science and engineering, there is room for both visionaries and skeptics. Visionaries play an important role in imagining what might be and stubbornly pursue a dream that may be difficult to realize, but which in the end, may be achievable. Skeptics identify the barriers, difficulties, pitfalls, and unknowns that impede the path, and point out the technical developments needed to enable fulfillment of the dream."*

- Donald Rapp

## CONTEXT

The global interest in putting humans on Mars is rising and there are today agencies as well as private interests looking into landing the first human on Mars in the 2030-ies.

Due to the different orbits of earth and Mars the journey would take somewhere between 6 and 9 months and can only be undertaken at certain times.

This means that the resupplies can only be sent at certain times, and these resupplies will take a long time to reach Mars.

As a result, the first humans on Mars will need to stay on the planet for some time and will need somewhere to live and work.

One option that NASA, among others, are currently investigating is sending a 3D printer that will prepare this dwelling before the humans arrive.

While still in its infancy, research has been put into additive manufacturing using local materials on other celestial bodies.

Goulas & Friel (2016) tests the possibilities of printing with lunar regolith using lasers to weld the material together, and Walsh (2019) writes about how AI Space Factory was awarded first place in a 3D printing challenge held by NASA with a technology that uses a novel mixture of basalt fibre (regolith) extracted from Martian rock and renewable plant-based bioplastic (commonly referred to as PLA) to build a habitat on Mars.

The findings of Goulas et al. (2016) suggest that the technology isn't currently viable for structures of larger scale, but AI Spacefactory have built models using their technology.

Based on the proven concept by AI Spacefactory, this thesis assumes a regolith and PLA mixture will be used for printing the habitat.

The European Space Agency (2019) are also investigating different options of 3D printing using in situ resources, initially on the Moon.

Once on site, astronauts can then print smaller objects using the printing method described by Goulas & Friel.

This thesis intends to investigate what such a dwelling could look like and presents a concept habitat based on those studies.

Due to the vast distance between the planets, communication with the 3D printer and the rocket delivering the 3D printer will be delayed by several minutes. This means that the arm or rocket cannot be controlled in real time, and some critical operations have to be carried out by the on-board computer.

The perhaps most critical operation, landing on Mars, will be one of the operations carried out by the on board computer.

As a result of this, the exact landing site cannot be predetermined as the computer must land where it deems most suitable.

In addition to this, the maps we have today of Mars are generally of too low of a resolution to be able to make an exact map of the site before actually landing on the site, and then it's too late to change the site.

Therefore, one objective of this thesis is to create a design that can be applied to various types of topology.

## METHOD

This thesis reaches a design proposal by exploring different options in iterations and expanding the level of detail with each iteration.

By defining how the printer works the thesis can also define the reach and limitations of the printer.

The thesis explores different options of what can be printed within these limitations. The thesis explores what effects different shapes have on the stability, material use, volume and floor space.

With a defined shape, the thesis tests that shape in different landscapes to see how well the design can adapt to changing conditions based on where the printer is landed.

The thesis also tests what effects the methods of printing has on constructions. How different paths of printing affects different functions and the tactility of the surfaces.

The thesis tests how the paths the printer uses for printing the habitat can be adapted into integrating with infrastructure and installations.

With the above-mentioned definitions and studies, the thesis has established a design logic for the general shape of the habitat, a logic for how to print the habitat, and tools to prepare for installations and infrastructure within the habitat.

This allows the thesis to utilize these definitions and tools to arrange functions and rooms within the habitat.

By studying the functions and their integration the thesis proposes a general plan of the habitat.

By arranging rooms and functions the thesis maps what infrastructure is needed to sup-

port these rooms and functions, and utilizes the previously established tools for infrastructure and installations to connect these rooms and functions.

To convey the final design proposal beyond illustrations and plans, a short novel is written about the first astronauts living in the habitat once the final shape of the habitat is determined.

This serves double functions. For the reader it conveys the design proposal in a way that traditional plans and illustrations cannot. But it also serves as a tool during the design process to test the designs beyond the plans and illustrations.

## DELIMITATIONS

The general purpose of this thesis is to propose a concept for a human habitat for the first astronauts to land on Mars.

As there was only a limited time to complete the thesis in combination with a goal of presenting a habitat all the way down to how to install infrastructure, the design options available have been culled regularly.

Other versions of the printer could have been tested but due to the time constraint the research has been limited to exploring the capabilities of one printer.

The same principle is applied to all levels of detail in the thesis. The thesis presents several different shapes for the habitat that are within the capabilities of the printer, but only one shape has been explored further. Inside this shape, different ways of adjusting to the landscape were explored and are presented in the thesis, but only one setup has been explored in detail.

Different principles for how to print the habitat were explored, but only one was explored to the level of detail where it was combined with installations of infrastructure.

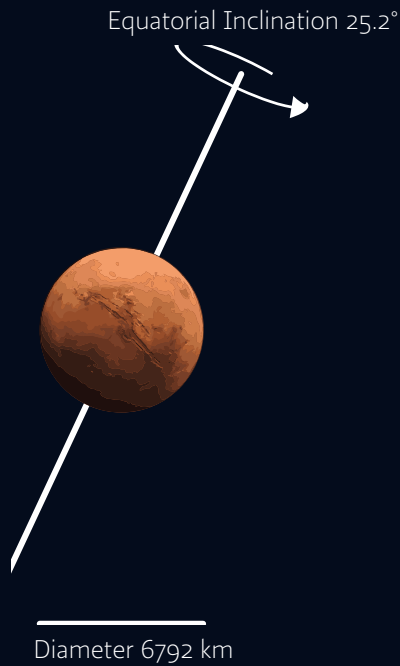
The concept proposed by the thesis is to be seen as an architectural proposal for a plausible Martian habitat based on current knowledge. The habitat is not expected to be able to be built exactly as proposed in this thesis, but the design and concepts are intended to be a plausible vision of what could be achieved.

Further research would be required into many different areas, perhaps most pressing, the production and exact properties of the regolith and PLA mixture proposed to be used to print the habitat.

As humans are still a long way from setting foot on Mars, all design proposals are speculative by nature.

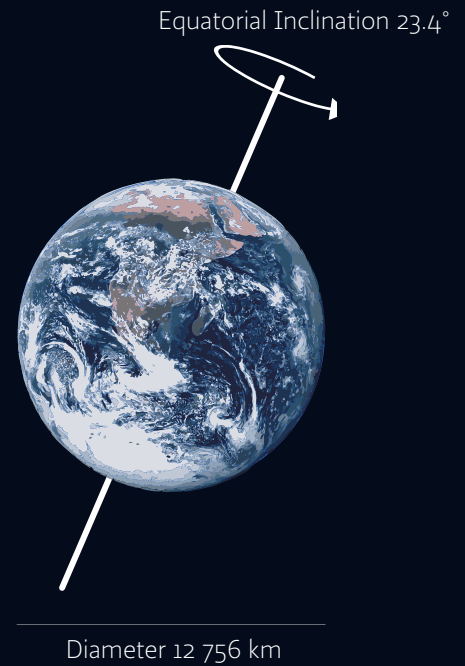
As the aim of this thesis is to explore potential designs for a habitat on Mars this thesis does not attempt to build upon other proposals. Instead it should be seen as a work on its own exploring new ideas and is not intended to be an addition or improvement of existing ideas or discourses.

# PLANETARY COMPARISON



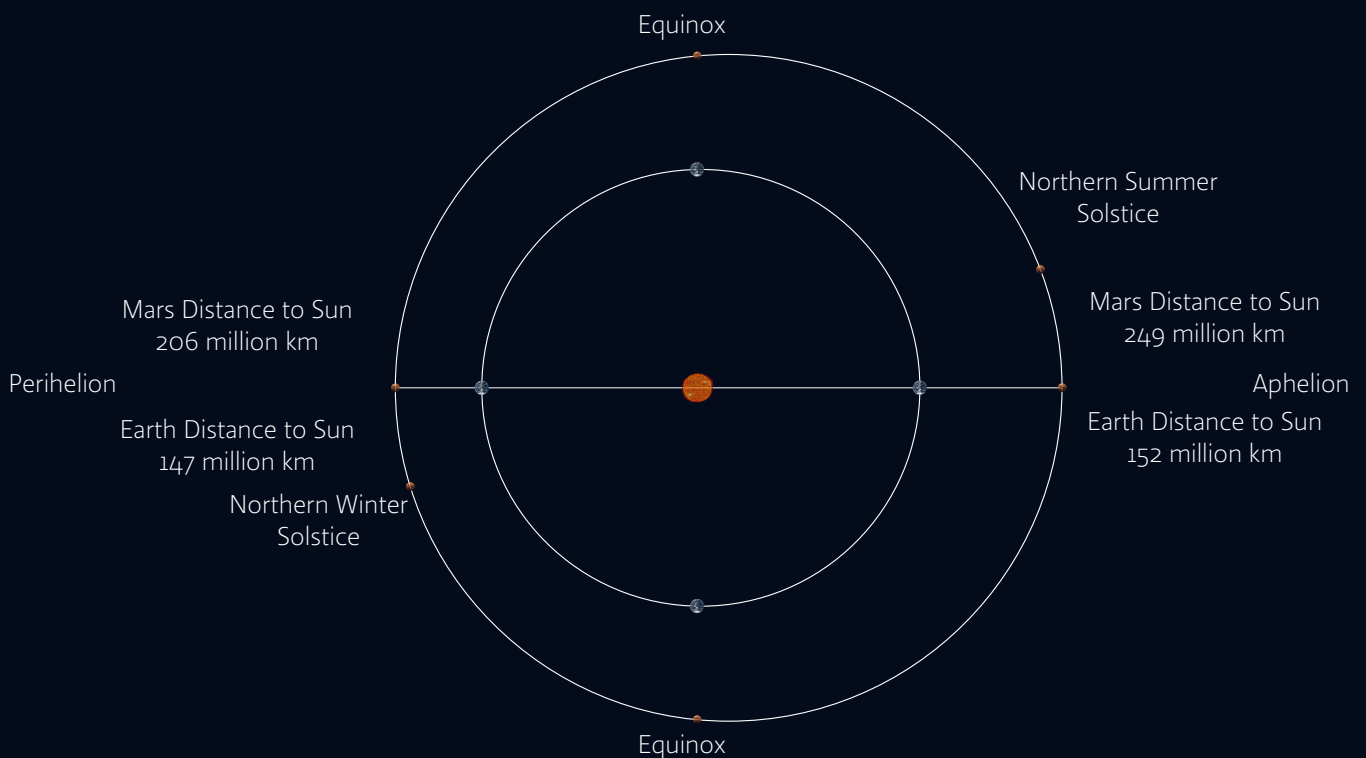
## Mars

Equatorial inclination:	25.2°
Length of day:	24 h 36 m
Year	687 days
Surface Gravity	3.71 m/s
Mean Surface Pressure	8 hPa
Orbit Eccentricity	0.094



## Earth

Equatorial inclination:	23.4°
Length of day:	24h
Year	365 days
Surface Gravity	9.80 m/s
Mean Surface Pressure	1013 hPa
Orbit Eccentricity	0.017



## Seasons on Mars

In many ways Mars is the planet in the solar system most like Earth. With an equatorial inclination and rotation along its own axis similar to Earth's, Mars experiences similar seasons and days as Earth.

The Martian day is slightly longer than the days on Earth, and a year is almost twice as long, but compared to other planets this is relatively close to what humans are used to.

As Mars is further from the sun a Martian year is 686.97 days long, which would normally make the seasons almost twice as long on Mars as on Earth. However, Mars' orbit around the Sun is also noticeably more elliptical than the orbit of Earth, with a perihelion of 206 million kilometres and an aphelion of 249 million kilometres.

This means that the northern summer is much longer than the northern winter, while the southern summer is much shorter than the southern winter. Since the northern summer is spent further away from the sun and the winter closer, the northern hemisphere has more stable temperatures while the southern hemisphere has colder winters and warmer summers.

## Atmosphere

Mars has a thin atmosphere consisting of mostly carbon dioxide, nitrogen and argon, compared to Earth's atmosphere composed of mainly nitrogen and oxygen. Due to the thin atmosphere the atmospheric pressure at the surface of Mars is roughly a thousand times lower than on Earth.

NASA's Mars curiosity rover has sent back measurements ranging from 6.8 hPa to 9.6 hPa depending on time of day and season, where the pressure on Earth averages 1013 hPa. This means that even if the Martian at-

mosphere had been made from of the same elements as the one on Earth, it would still not be breathable. Water would evaporate quickly and the human body would suffer serious damaged if exposed to the atmosphere.

Another factor to consider is that a structure on Mars with humans living in it would need to have a much higher air pressure inside than what is on the outside, and the structure would need to be strong enough to withstand the pressure difference between the outside and inside.

## Gravity

The mass of Mars is only about a tenth of the mass of Earth and has a much smaller gravity well. However, Mars is smaller than Earth and the surface is closer to the centre of mass and since the gravitational pull of objects is based on the distance to the centre of mass of the object you still experience about a third of the gravitational pull of Earth on the surface of Mars.

## HISTORICAL REFERENCES

While Mars is definitely a unique challenge of a scope that humanity has never before undertaken, there are some similarities to for example the Antarctic expeditions. The first explorers built small huts to gain a foothold on the continent, and with time these small settlements expanded. The Discovery Hut built by Robert F Scott (Figure 1) in 1902 today stands with the McMurdo station in the background, a research station that today has expanded to a small settlement housing over 1200 people.

Back in 1902 just getting to Antarctica was a trip on a similar time-scale as reaching Mars and all necessities had to be brought on the expedition, just like a Mars expedition would need.

The cold and arid climate on Antarctica technically makes it the largest desert on the planet and during the winters, most contact with the rest of the world is shut down. The Amundsen Scott base situated at the geographic south pole is for all intents and purposes completely isolated during the winters as it's considered too hazardous to fly to the base during the winters. The residents are isolated from the outside world for nine months and despite modern technology like satellites the coverage at the poles is limited to only a few hours per day so contact with the outside world is limited.

The air is so dry, cold and thin that many of the scientists who go there have a hard time just getting from the transport plane to the base, a distance of roughly a hundred meters. The equipment required to go out often need more than 10 minutes just to put on, and scientist who go there has reported that they felt like astronauts on a different planet. (Siliezar. J. 2019, 11)

There are a few lessons to be learned from looking at the human presence at Antarctica. One being the time scale. It's been more

than a hundred years since humans started exploring the continent and for the first fifty years exploration and exploitation of the land was slow. People lived in shelters rather than functioning cities. It took a long time to set up an infrastructure and even today the population is barely above a thousand people living there. We still cannot come and go as we please and things we normally take for granted like communication with the world is only available at certain times.

Antarctica was not populated or built in a few years. Not even in decades. While we would of course like to imagine a Martian colony, it's unlikely that we will see more than a few bases on Mars the first century after landing there.

Another lesson to be learned is how living in these conditions affects humans. During the winters temperatures go so far below freezing that just putting on clothing enough to keep you from freezing to death in minutes takes time equal to putting on a space suit.

Organisations like "The Mars Society" have build mock-ups of Mars Habitats in the Antarctic that they have people live in to simulate a Mars expedition in. Pletser (2018) has published parts of a journal from staying in one of those habitats.

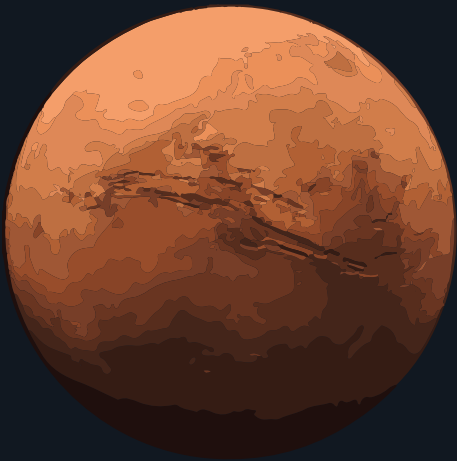
Living on the south pole during winter is likely the closest we can come to simulating living on Mars. Isolated in an enormous desert. Going outside without protection is likely to kill you, and we need to bring all the supplies needed during our stay.

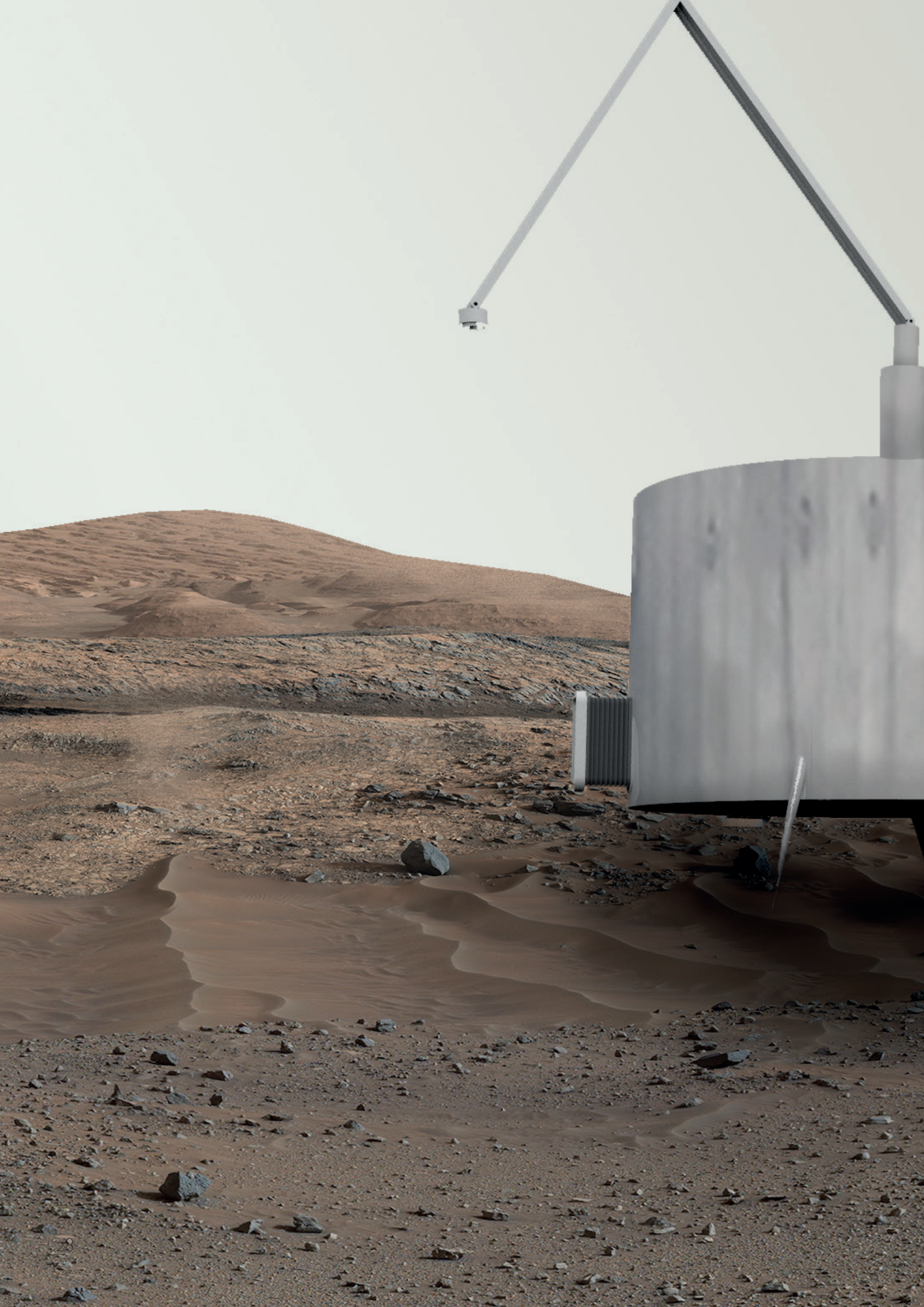


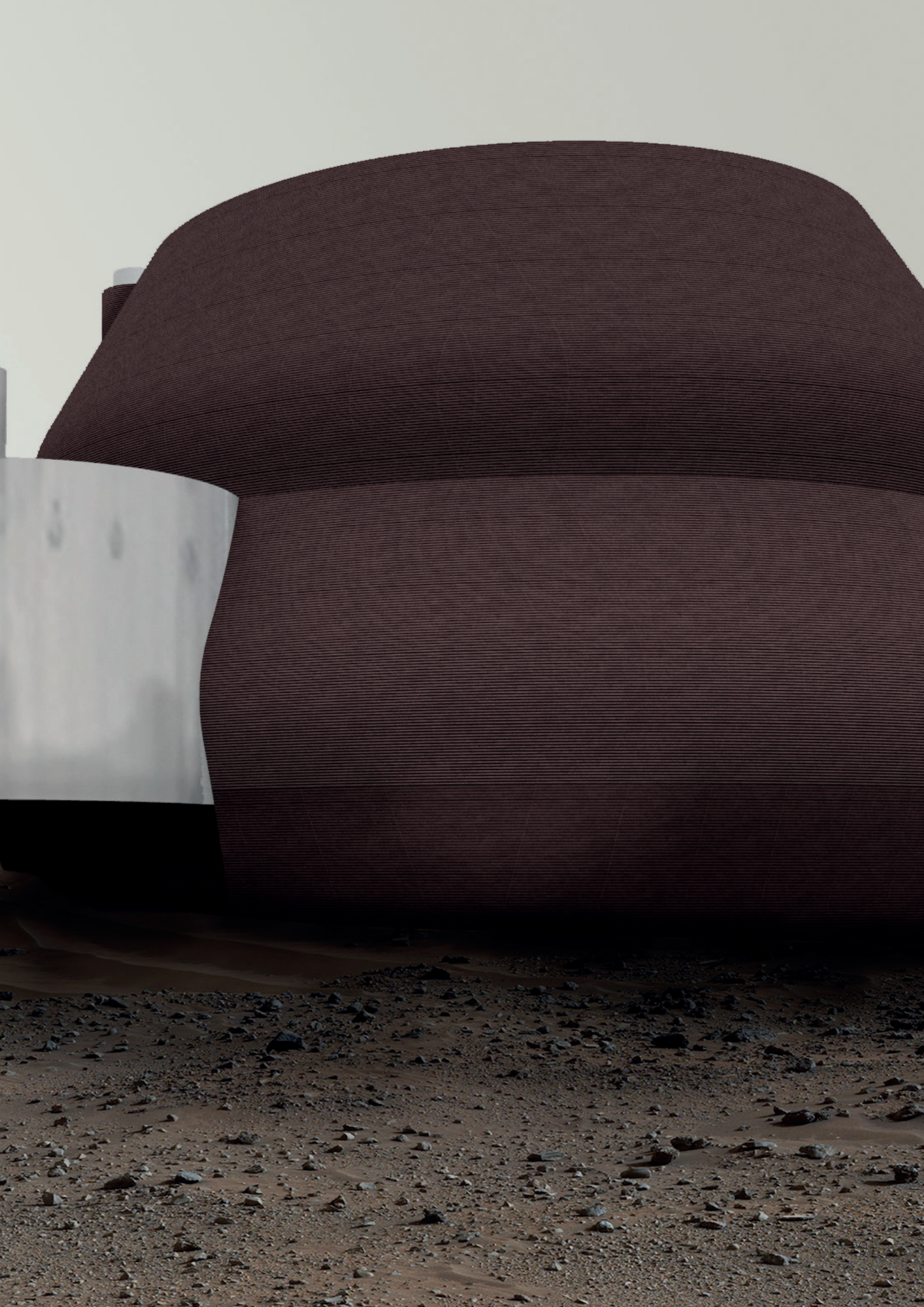
Figure 1. (Discovery Hut and McMurdo Station, 2008). Discovery Hut was erected by the Discovery Expedition to Antarctica in 1903 and can be seen here with McMurdo base in the background. The small original hut was prefabricated and mostly used to live in and establish a foothold on the continent. Considering the technology available at the time and the remoteness of Antarctica, the expeditions going to Antarctica were in many ways just as isolated and on their own as a Mars expedition would be. CC-BY-3.0



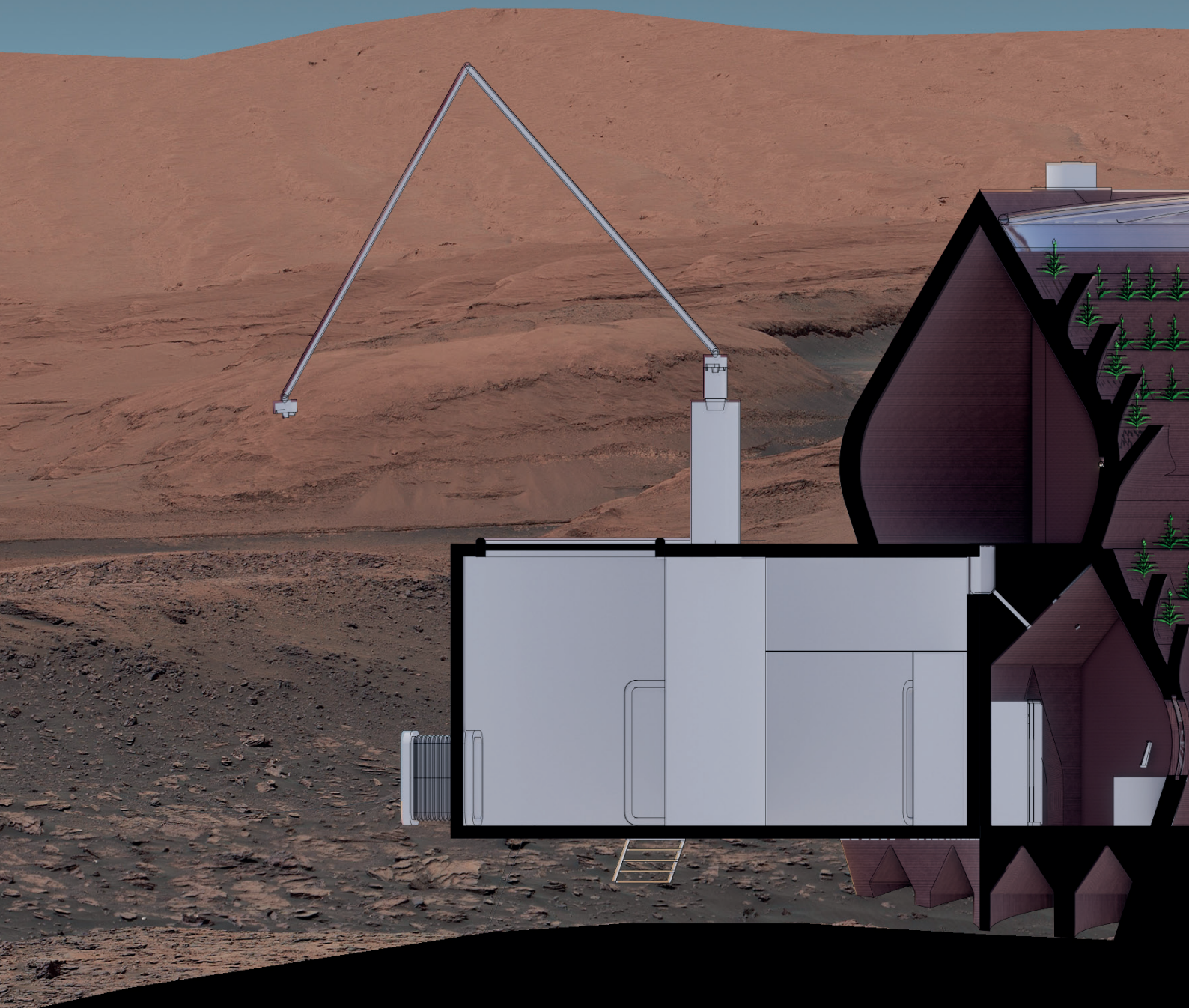
# THE HABITAT

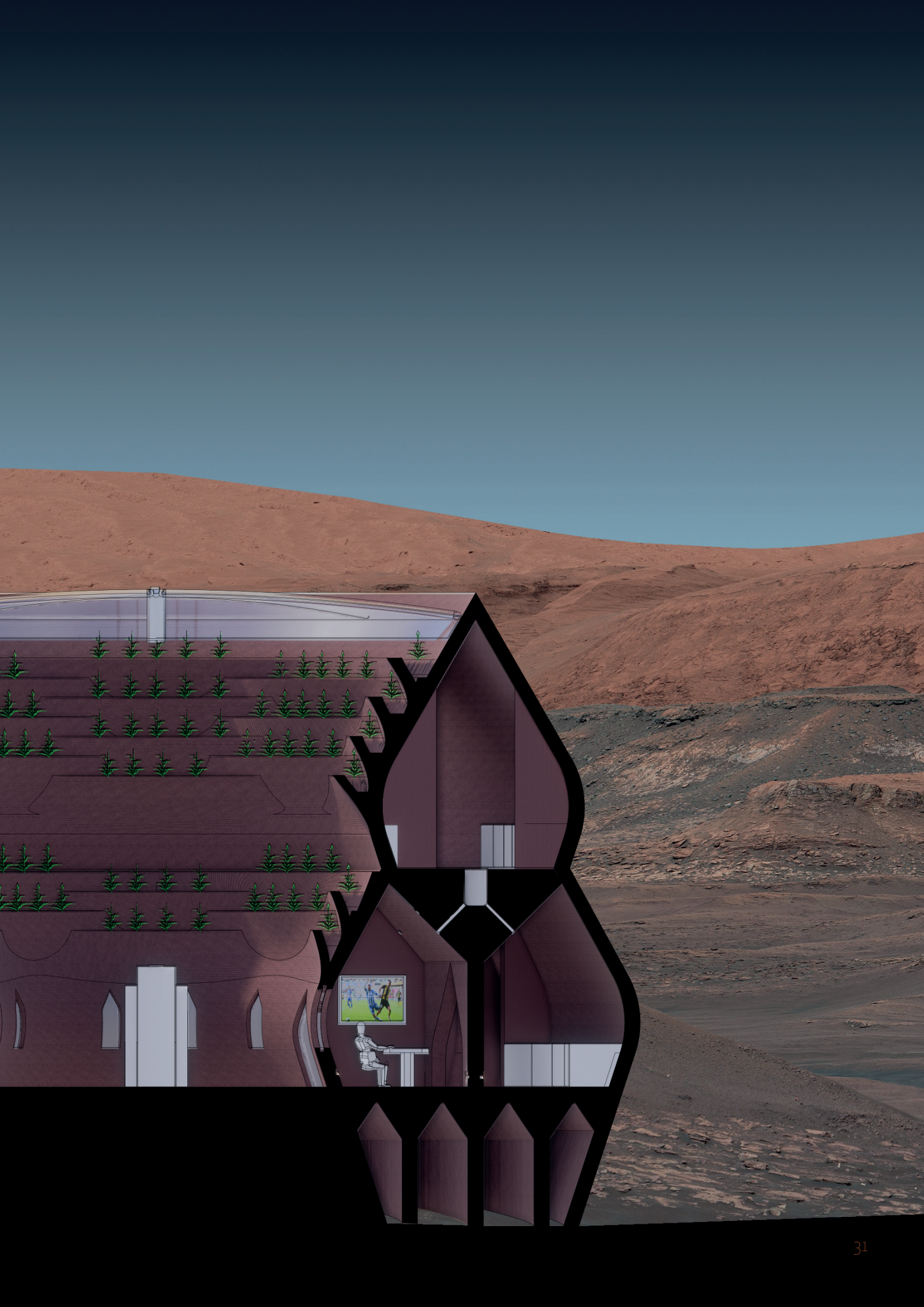




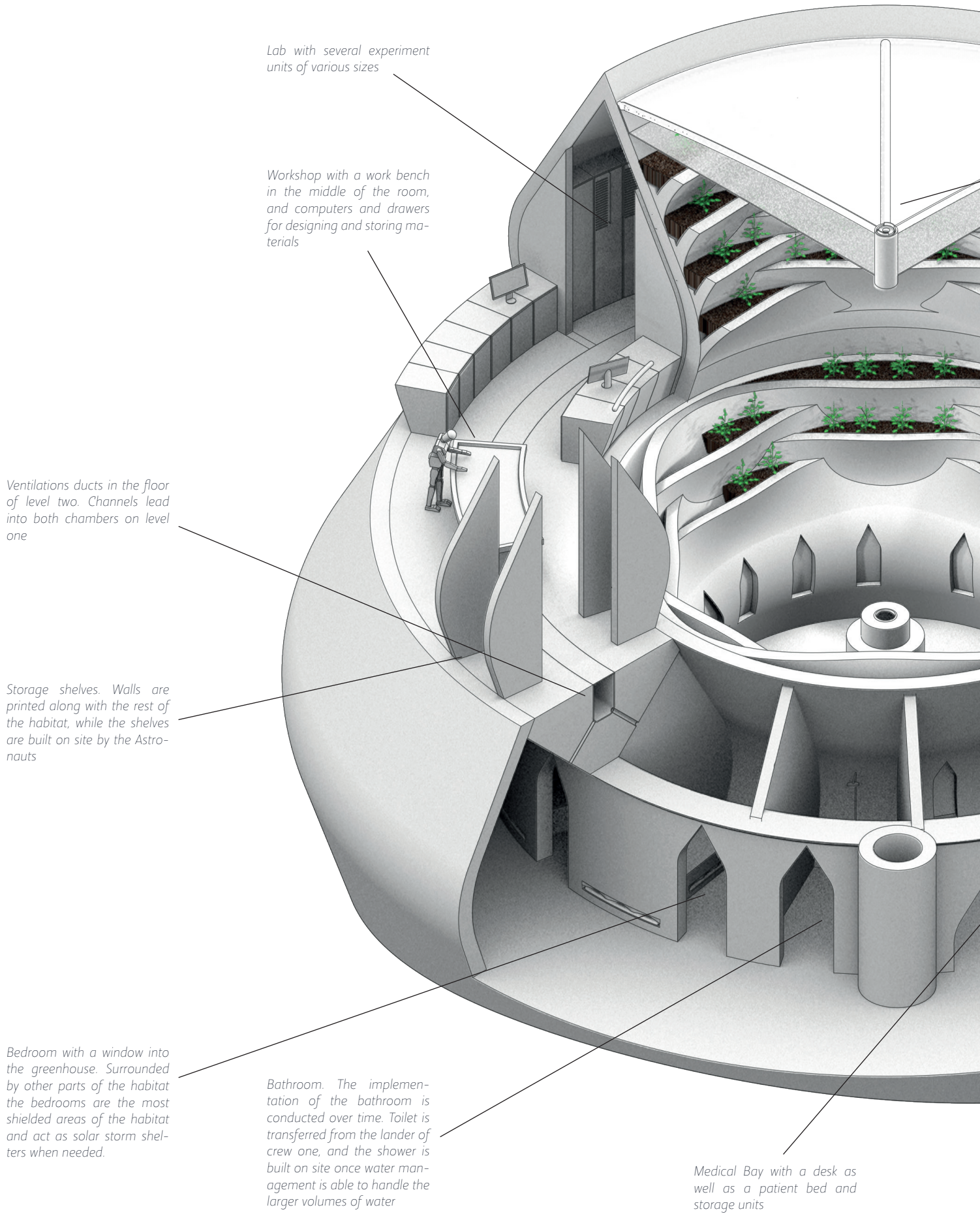


# ELEVATION





# CUTOUT



Lab with several experiment units of various sizes

Workshop with a work bench in the middle of the room, and computers and drawers for designing and storing materials

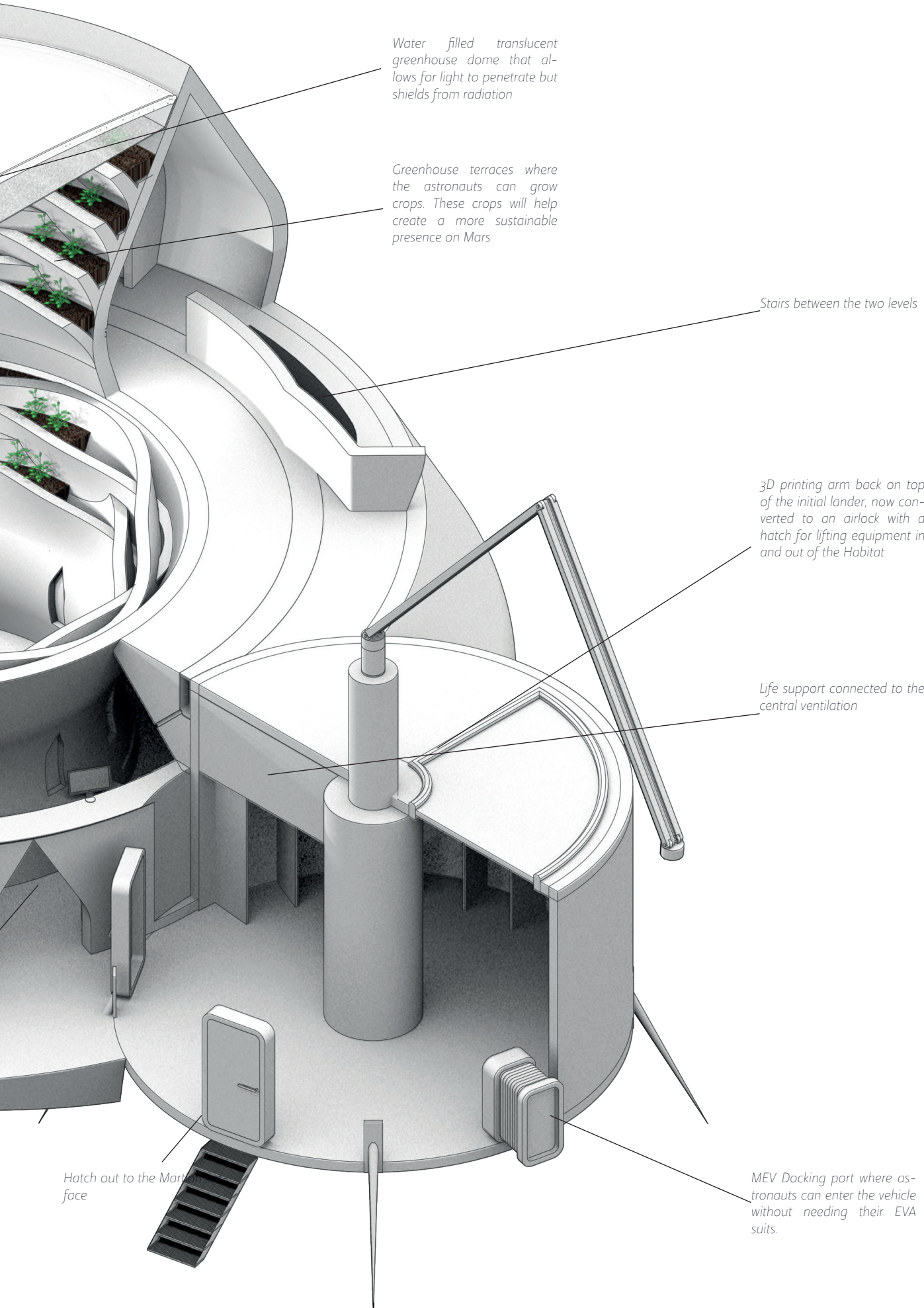
Ventilations ducts in the floor of level two. Channels lead into both chambers on level one

Storage shelves. Walls are printed along with the rest of the habitat, while the shelves are built on site by the Astronauts

Bedroom with a window into the greenhouse. Surrounded by other parts of the habitat the bedrooms are the most shielded areas of the habitat and act as solar storm shelters when needed.

Bathroom. The implementation of the bathroom is conducted over time. Toilet is transferred from the lander of crew one, and the shower is built on site once water management is able to handle the larger volumes of water

Medical Bay with a desk as well as a patient bed and storage units



Water filled translucent greenhouse dome that allows for light to penetrate but shields from radiation

Greenhouse terraces where the astronauts can grow crops. These crops will help create a more sustainable presence on Mars

Stairs between the two levels

3D printing arm back on top of the initial lander, now converted to an airlock with a hatch for lifting equipment in and out of the Habitat

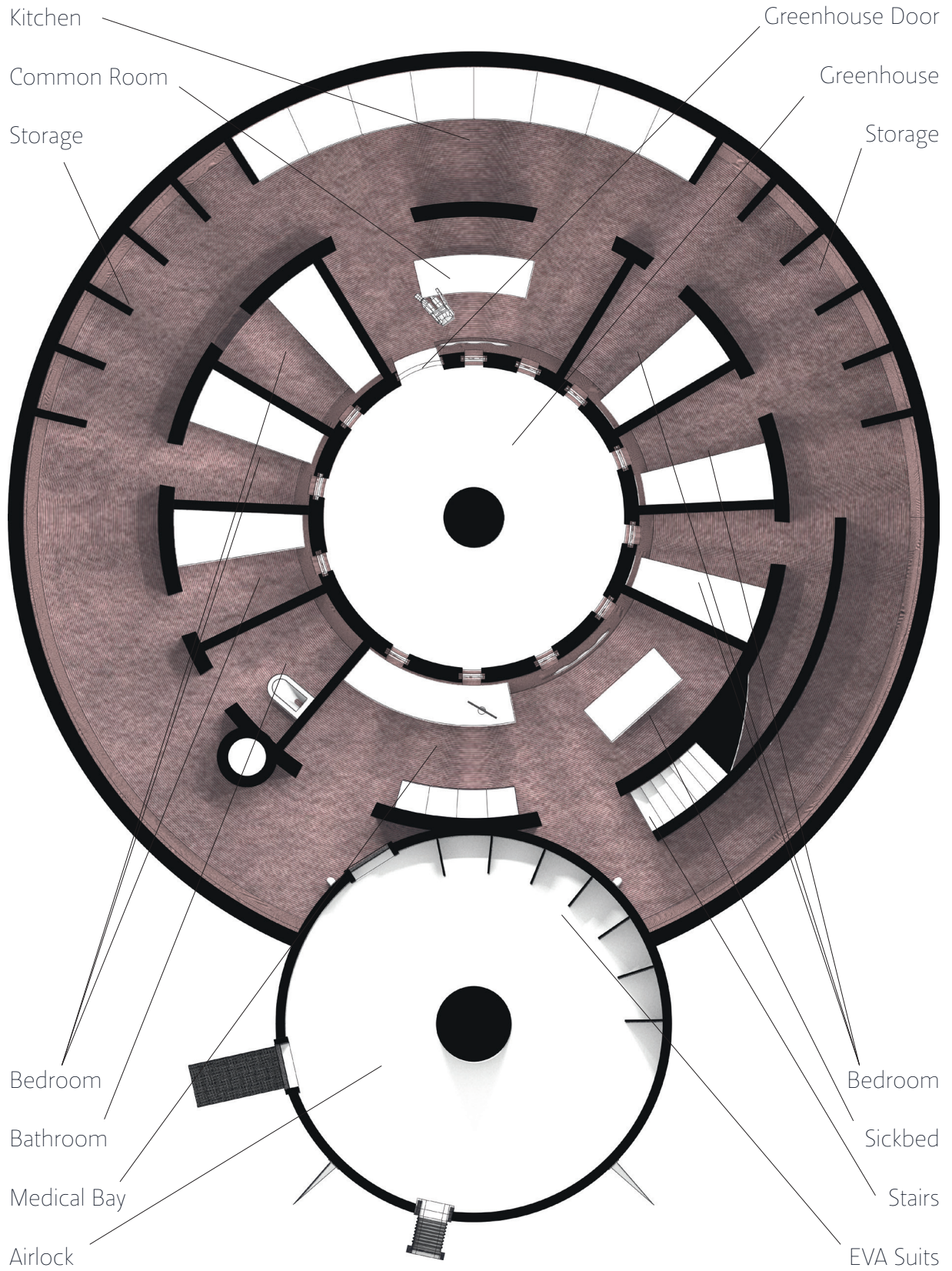
Life support connected to the central ventilation

Hatch out to the Martian surface

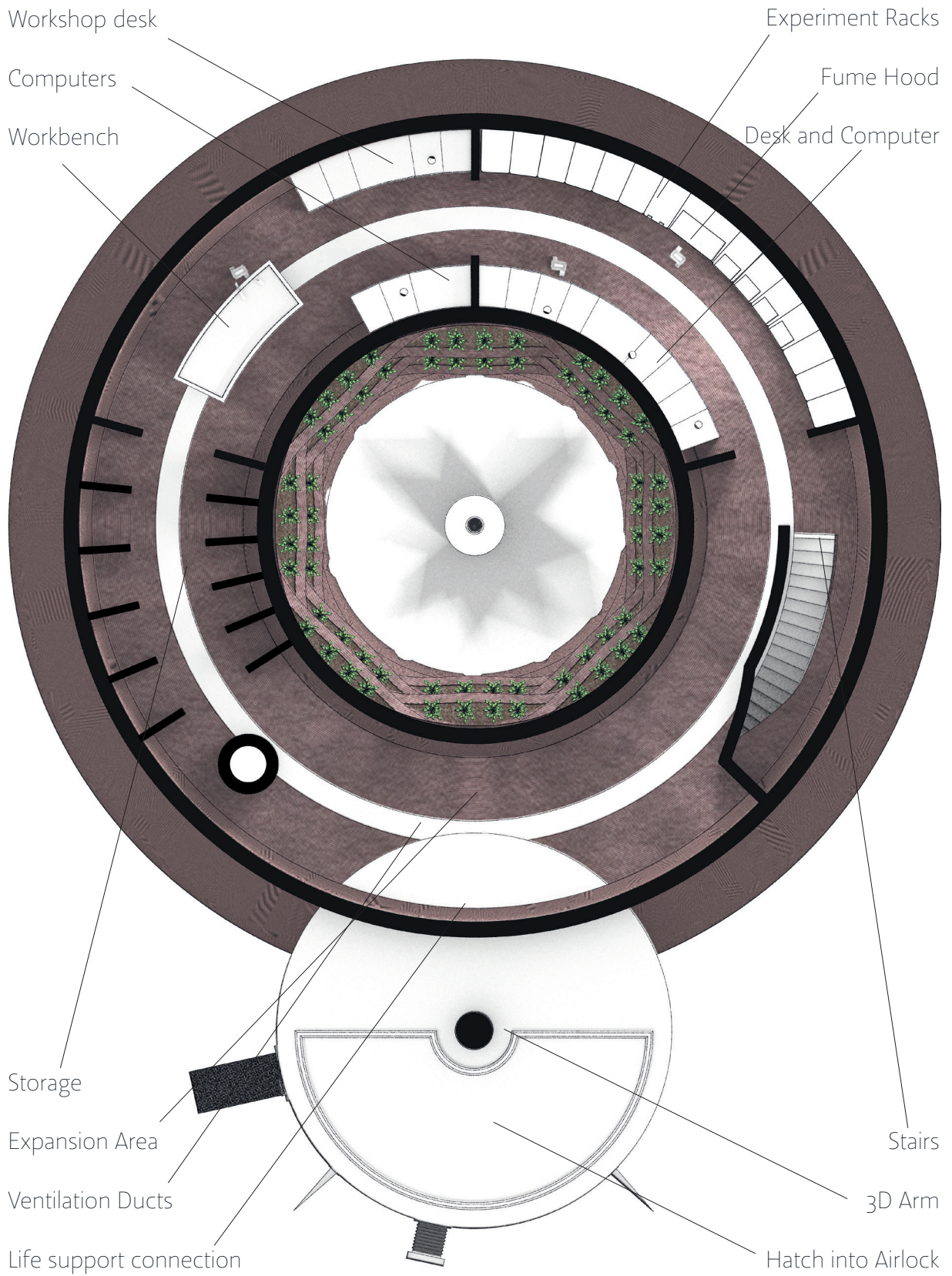
MEV Docking port where astronauts can enter the vehicle without needing their EVA suits.

# PLANS

## Level One

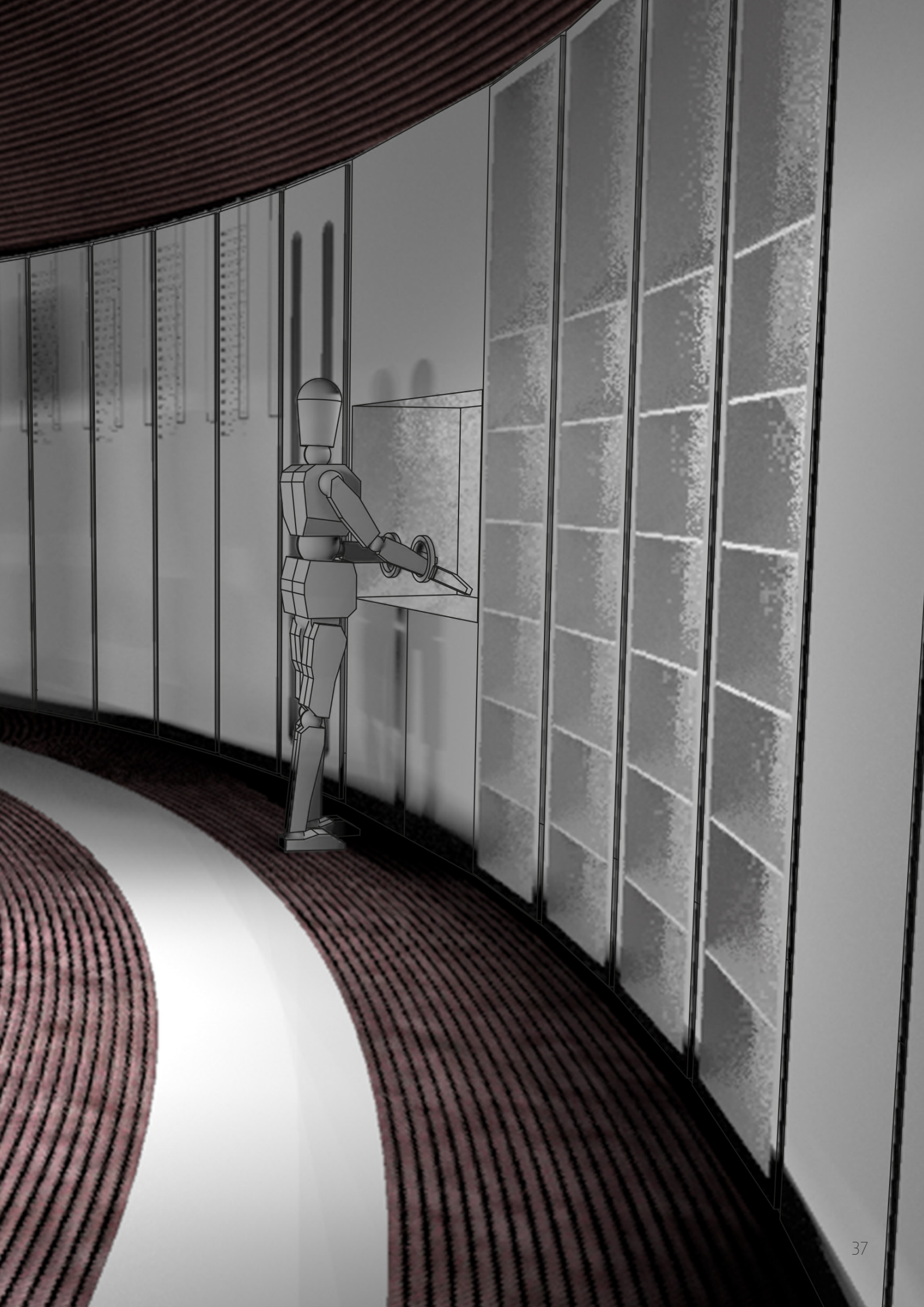


# Level Two

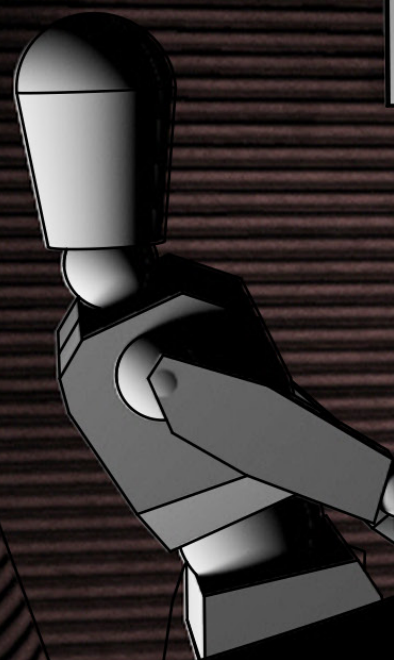


LABORATORY



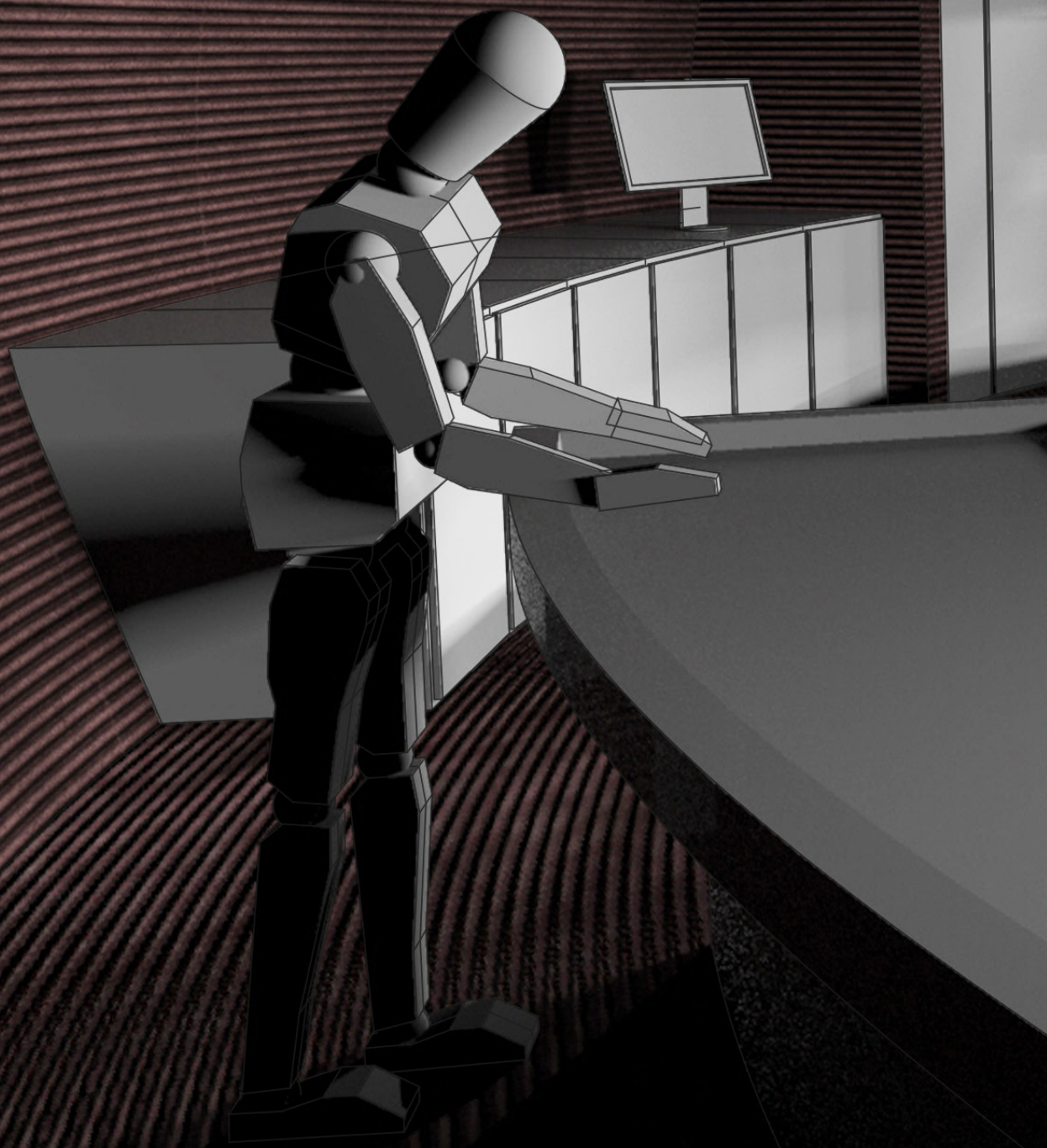


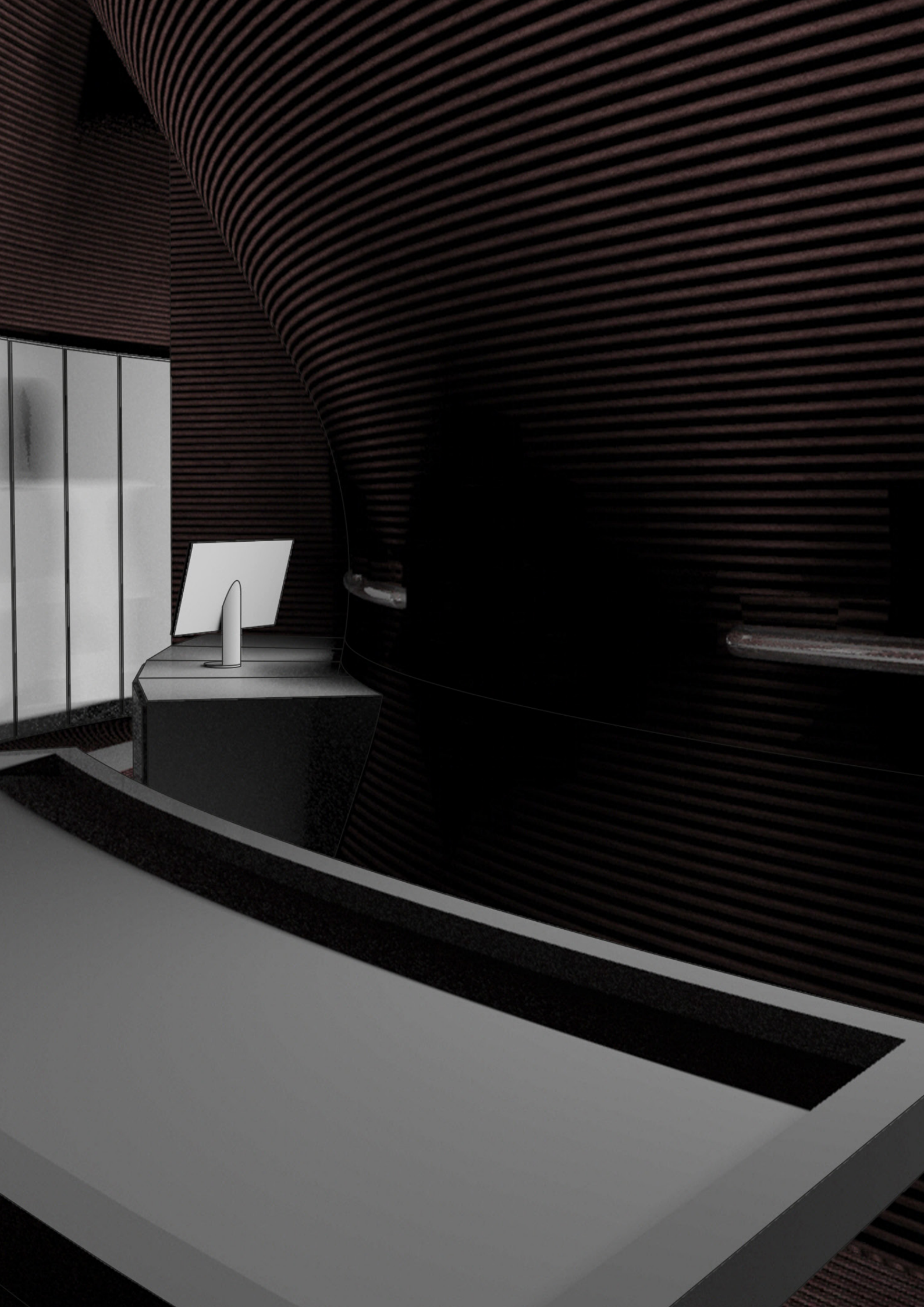
COMMON ROOM



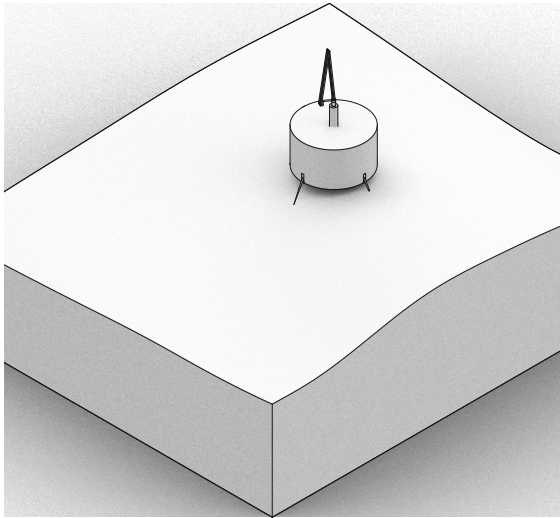


WORKSHOP



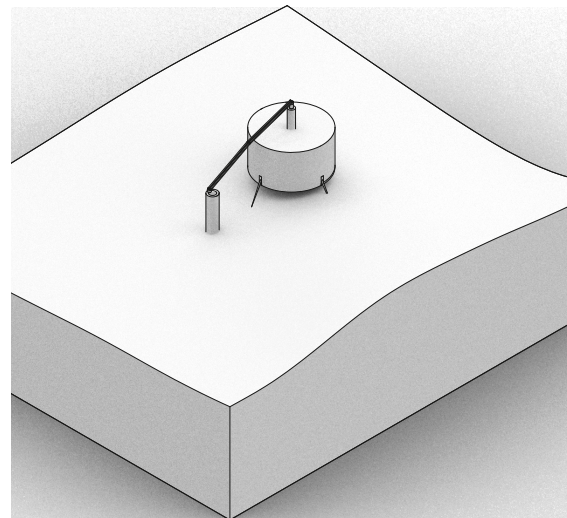


# CONSTRUCTING THE HABITAT



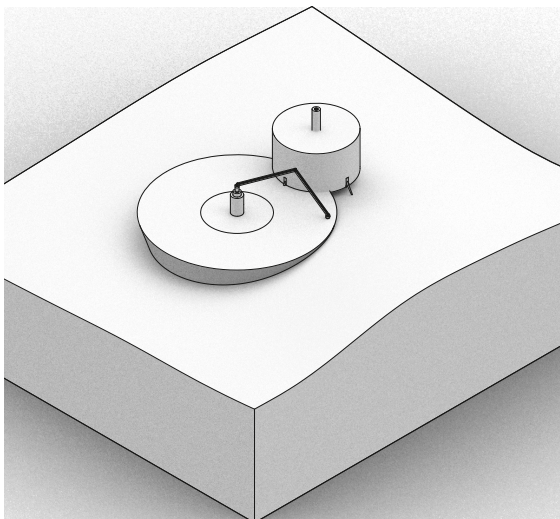
## Landed

The landing module lands and the arm is unfolded. The arm then begins to scan the surrounding environment. The arm can detach from both ends much like the Canadarm 2 (Canadian Space Agency, 2018)



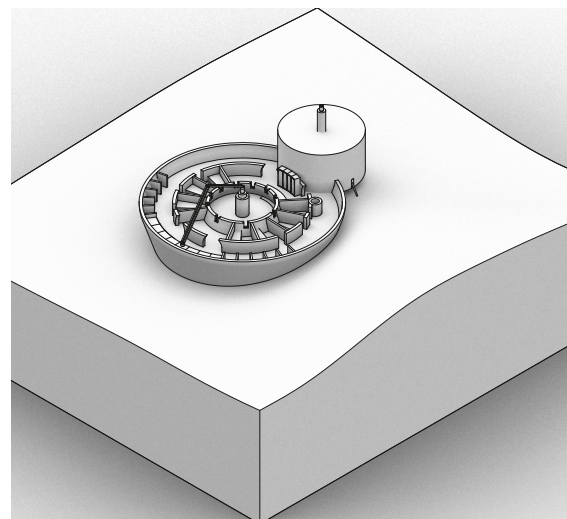
## Building the platform for the printer

The printer then builds a platform next to the lander module. When that platform is finished the arm places one of the docking ports in the platform and moves to the docking port.



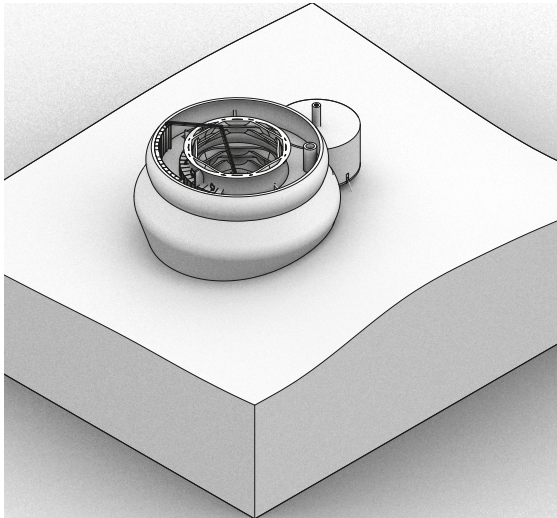
## Building the foundation

From it's new position the arm proceeds to build the foundation of the habitat around itself.



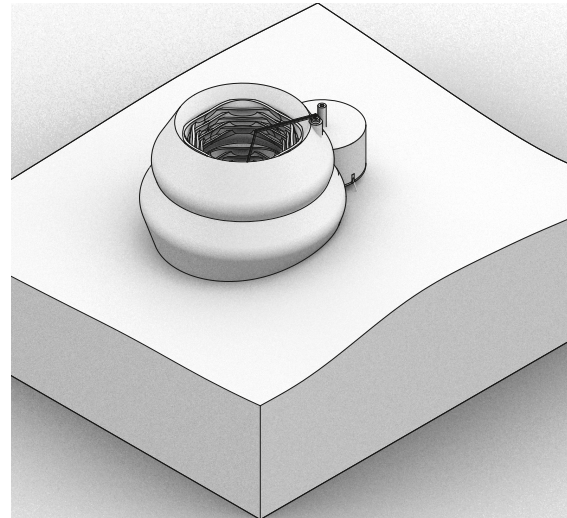
## Placing installations

Some equipment for the habitat is brought with the lander module and is lifted inside the habitat by the arm. The equipment for the first level is lifted into place when the height of the printed volumes passes the height of the equipment.



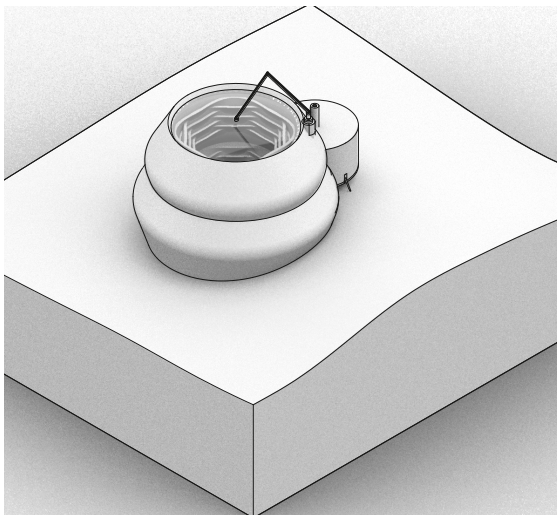
### Placing installations level 2

The printer continues upwards. Due to the arching walls on the second level the equipment cannot be lifted into it's final positions. Instead the arm lifts them into the correct sectors, and final installation will have to be completed by the astronauts.



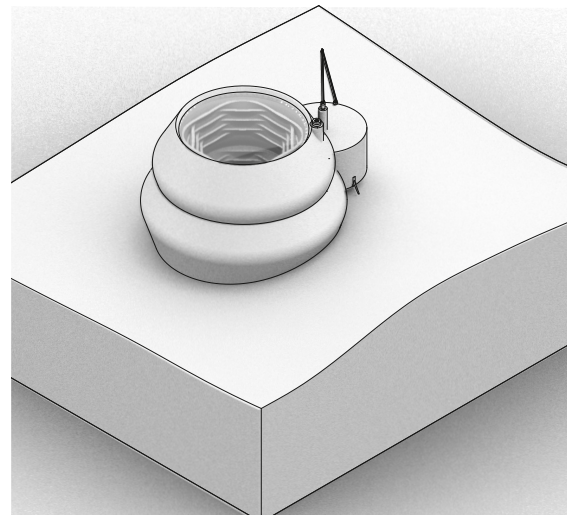
### Finished print

When the printer has completed printing the habitat volume it will install a third docking port, on top of the habitat. This docking port can be used in the future for extended reach of the arm around the habitat.



### Installing greenhouse roof

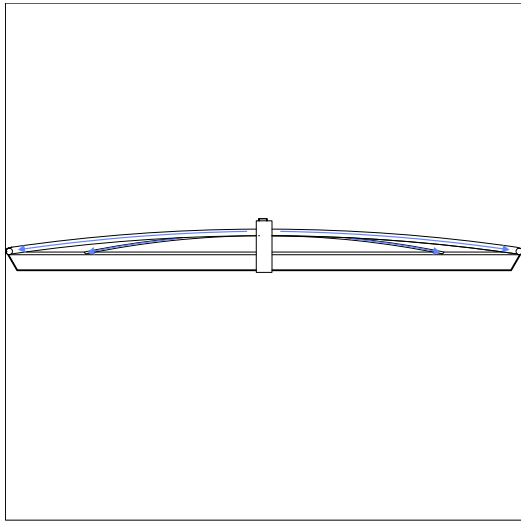
The arm moves up to the newly installed docking port and lifts the roof of the greenhouse into place. The structure is inflated with water which will protect the greenhouse from radiation.



### Operational position

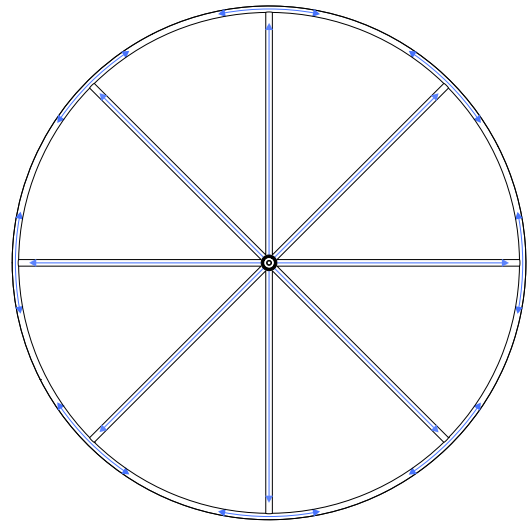
Once the greenhouse roof is in place the arm moves back to its initial position on top of the lander module, now used as an airlock. From there it will continue operations once the astronauts arrive. From here the arm can lift supplies and new equipment into the airlock or perform additional construction by moving to new docking ports.

# INSTALLING GREENHOUSE TOP



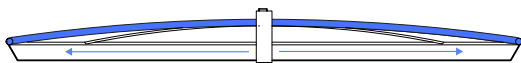
## Inflating seal and spokes cutout

In the middle of the greenhouse roof there is a docking port that can attach to the printer arm. The arm lifts the deflated greenhouse top into place at the centre of the habitat.



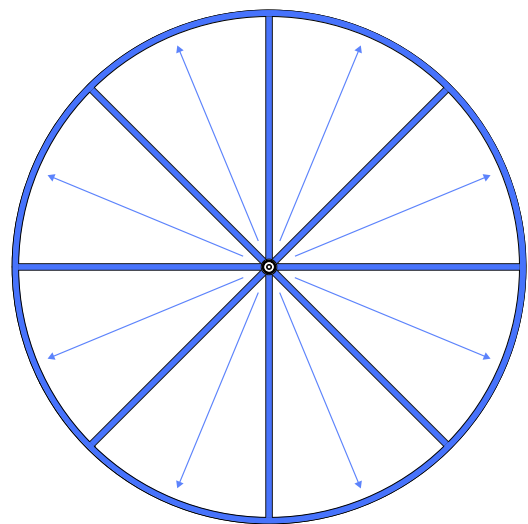
## Inflating seal and spokes top

The greenhouse top is designed with two different types of chambers. Via the docking port the arm inflates the top by filling spokes and an outer ring with water. The spokes and outer rings give the top its shape when inflated.



## Filling cutout

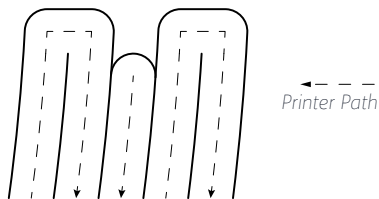
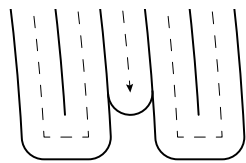
When the spokes and outer ring has been filled the shape of the greenhouse top is established. The the arm can then position the top more precisely in order to fix it to the printed walls.



## Filling top

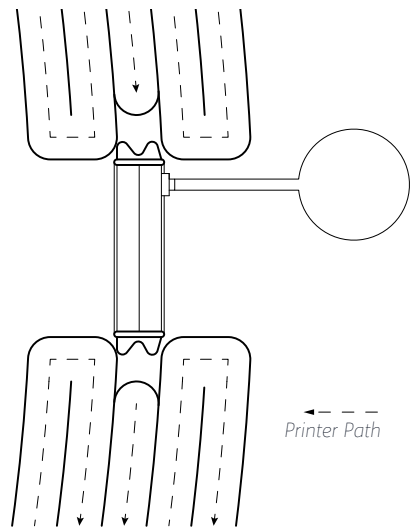
Once in place, the rest of the top is filled with water, adding weight which further fixes it into place.

# INSTALLING WINDOWS AND DOORS



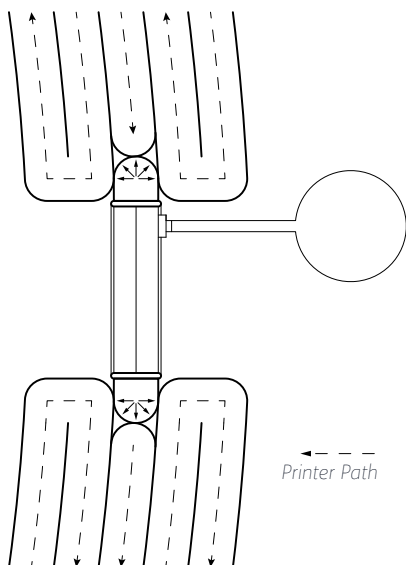
## Printed Window upon arrival

When the crew arrives at the habitat the openings for the windows will be empty. The two outer layers on each side will be connected and the fifth middle layer's printed path is a bit shorter than the outer layers.



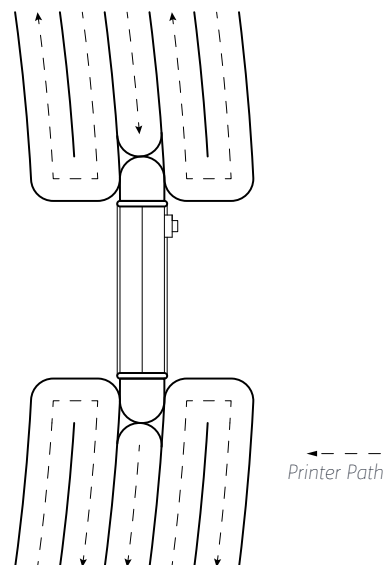
## Placing the window

A window with an inflatable frame will be manually placed in indentations created by shortening the middle path. The inflatable window has a small intake in the bottom right corner where a pump is connected.



## Inflating

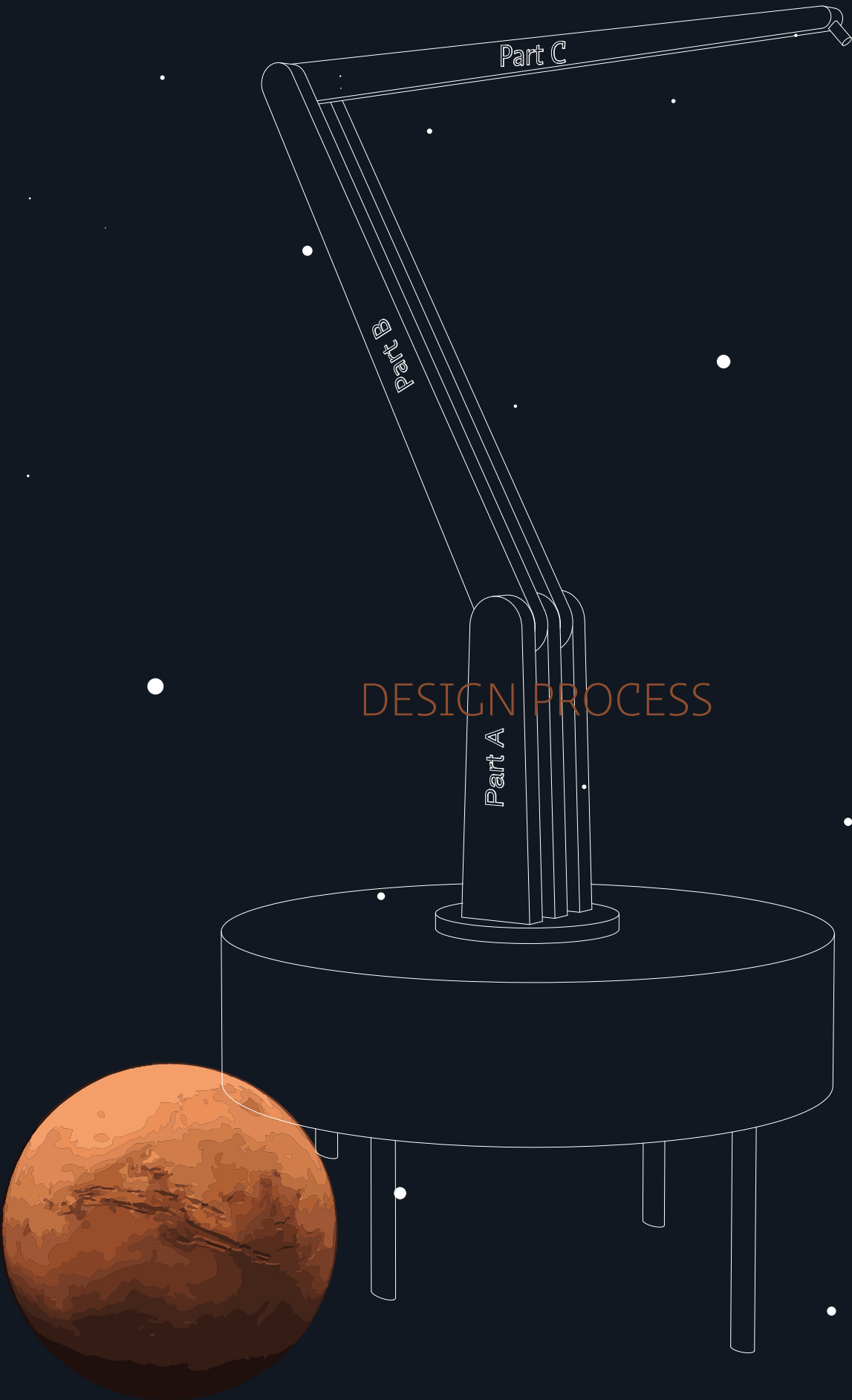
The window is inflated until it has locked into the wall. The internal pressure in the window creates a tight seal against the environment around it.



## Installed window

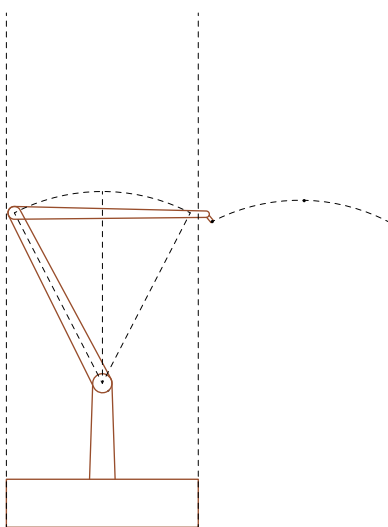
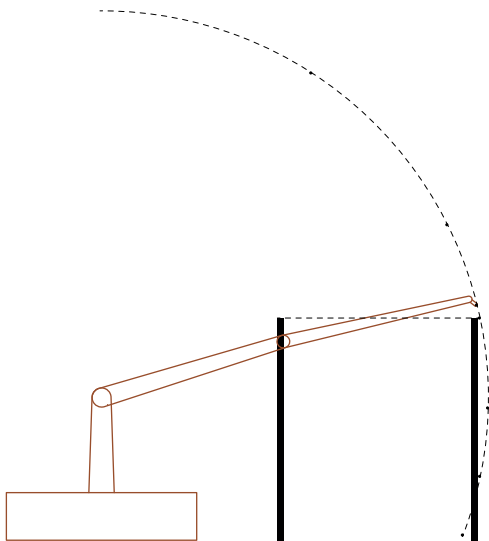
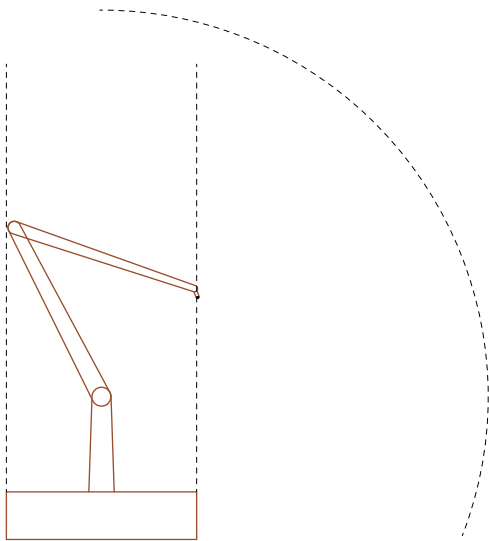
Once the window has been sufficiently inflated pump is removed and the inlet locked. The crew can now proceed to inflate the other windows.





DESIGN PROCESS

# PRINTABLE AREA



The design of the habitat has been steered by speculations on a construction process. Instead of sketching a design and adjusting the construction to that design, this thesis starts with a construction process, explores it and base the designs of speculated effects of that process.

This chapter will set up a printable area within which the arm can always print designs, so that several designs can be tested. It should be noted that it is possible with specific designs to reach outside of this area, but since the aim is to define an area for testing within, this thesis will limit the design proposals to within this area.

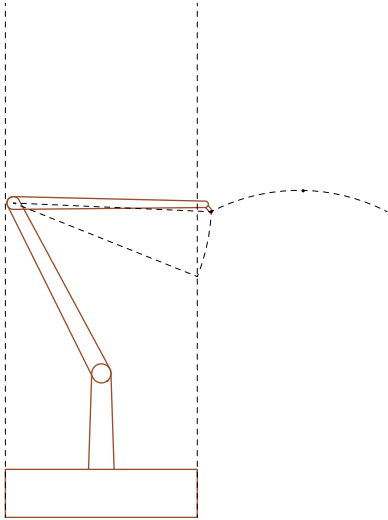
To allow for free movement around its axis, the arm is not allowed to print within a radius of 2,5m from its own axis.

Given how 3D printers build in layers evenly from the bottom up, the arm cannot always print to its full extent without colliding with previously printed layers, as illustrated here.

How far the arm can reach without hitting previously printed structures is defined by where these structures are built.

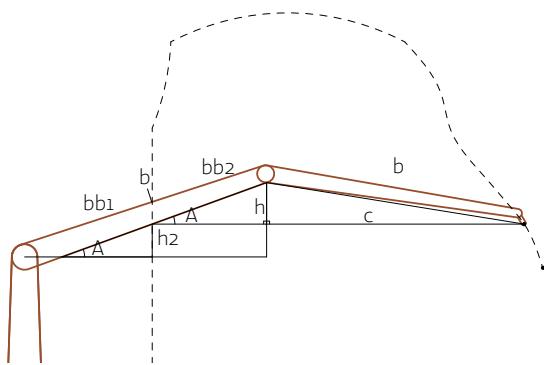
In order to define a printable area, this thesis assumes that the printer always prints as close to itself as possible. This comes with an acknowledged cost of limiting the furthest reach a bit.

In order to define where it can print, the thesis starts at the top. Part C of the printer cannot be tilted upwards and still print without risking a collision. The ceiling of what can be printed is thus defined by what the arm can reach with part C levelled. The reach of part C in this configuration is then a result of the movements of part B, which in turn is defined by an arc with a radius equal to the length of part B, which in this case is 6 meters.



In order to allow part C to be folded back it cannot print anything that limits this folding. By placing part B at the edge of what is allowed within the limits of the base, the limits of the printable area can be defined using another arc, this time based on the length of part C, which is also 6 metres.

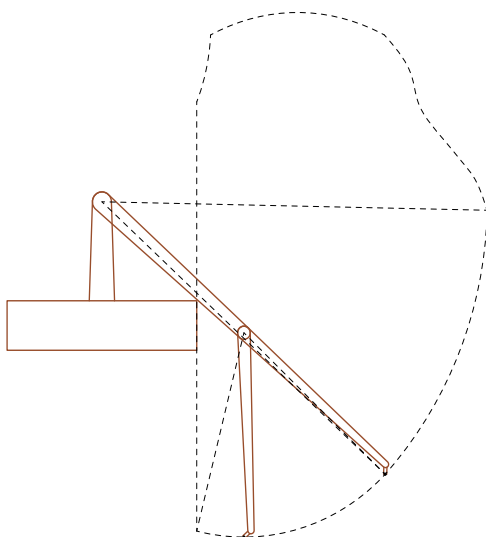
To define the limits of the rest of the walls for all situations where the angle A is between 0 and 90, the thesis reverts to some trigonometry. If part B and C act as hypotenuses for two triangles, it is known that the hypotenuse (b) is always 6 metres. As the height of the layer currently being printed is known, the height of h2 is also known.



By dividing part B into two parts, one that is within the area that cannot be printed in (bb1), and one in the printable area (bb2) b can be defined as  $bb1+bb2$ .

With the height of h2 and the angle A, bb1 can be found and thus, since  $b-bb1=bb2$ , bb2 is also found.

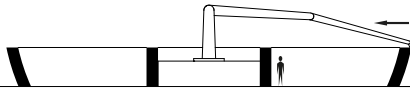
With bb2, and given that angle A is the same for both bb1 and bb2, h can be found. With h determined the base of both triangles within the printable area can be found. Adding both bases gives the horizontal reach of the printer arm for each layer it prints.



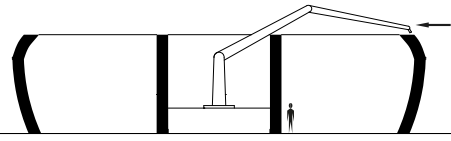
For angles above 90 the reach is easily calculated using arcs since there is no risk of part C colliding with previously printed structures. The printable area can be defined as an arc with the radius of the combined length of part B and C (12m)

When reaching an angle where part B collides with the base of the printer, the rotation of part B cannot go any further, and from this point on, the edge is defined by an arc with a radius equal to the length of part C (6m).

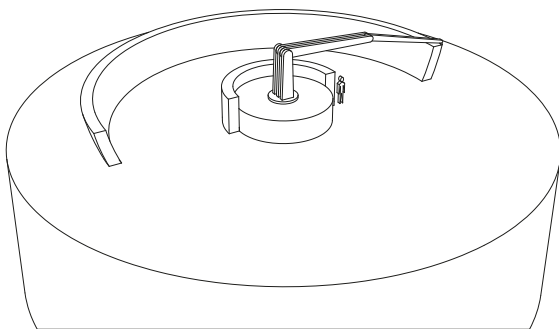
# METHODS OF PRINTING



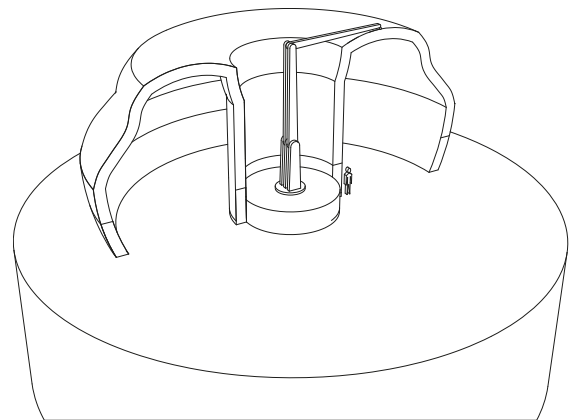
The arm will start at its furthest reach to start each layer. Rotate around, and then move close to the centre.



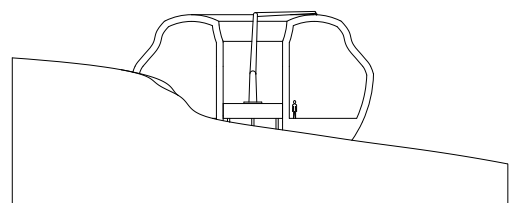
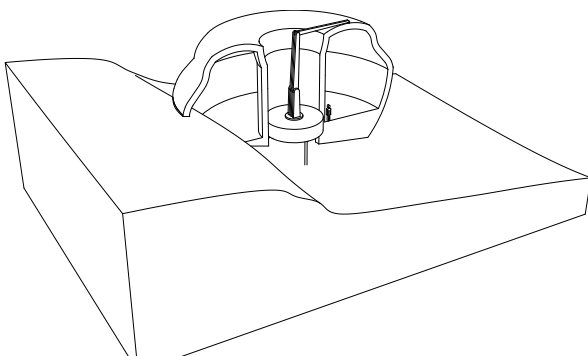
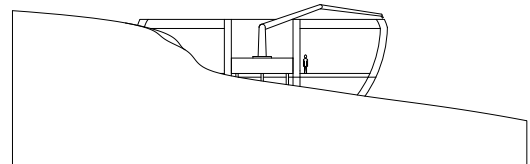
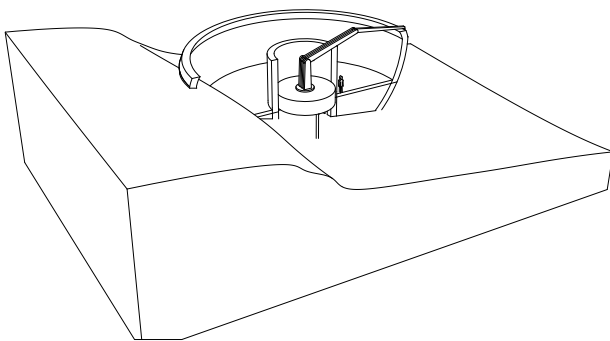
Layer on layer will be printed using this "outwards in" method of printing.



These figures illustrate how the arm would print the maximum allowed volume from bottom to the top

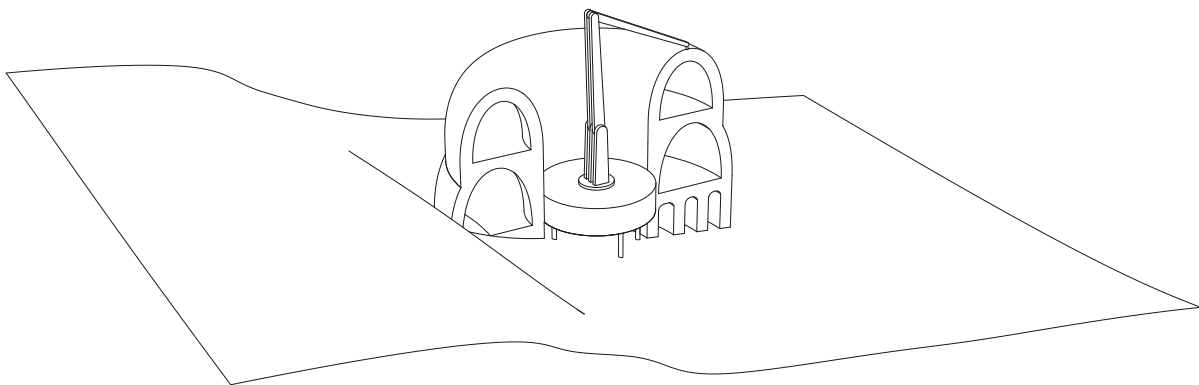
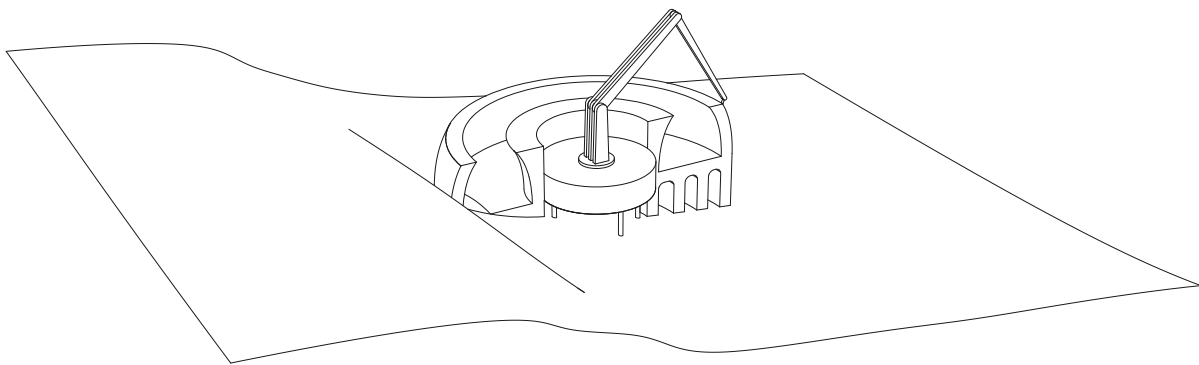
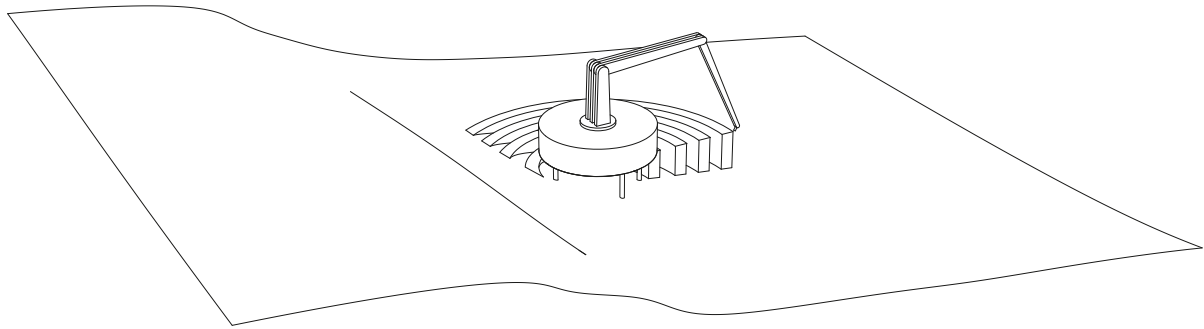


This shape puts the arm at its maximum reach just when finishing the roof.



These figures show the same process in an uneven terrain. Since the printer stands on legs and since it prints bottom up it won't

be affected by the uneven terrain. However, the terrain will seep into the volume and reduce the maximum printable volume.



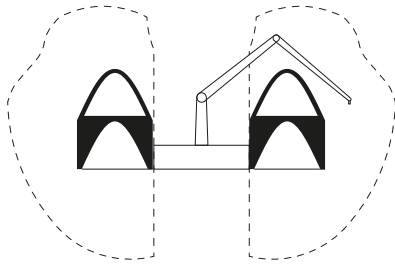
Maximum volume is however not necessarily the most useful volume as humans on Mars are, just like on Earth, bound to the surface by gravity, and in order to take advantage of the height with which the printer can print, we need to add more levels.

One drawback of printing bottom up is that everything we print needs to be supported from below and supporting the floor of the second level

When printing in terrain we also need to build some sort of support for the first level if we don't want to have a solid piece of print several metres high at places below it.

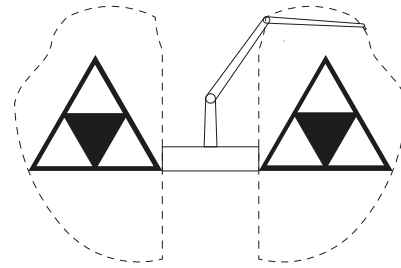
The model pictured above has an arced wall structure that supports the floor on the levels above, and in order to save material below the first level the floor is printed on several of pillars.

# SHAPING THE HABITAT



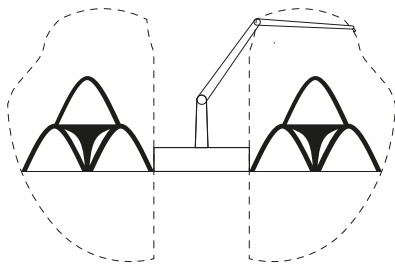
## Arc on Arc

When adding a second level to the structure it needs to be supported from below. As the arm cannot print beams over open space, it needs the walls to arc to support the floor. This adds a lot of wall material.



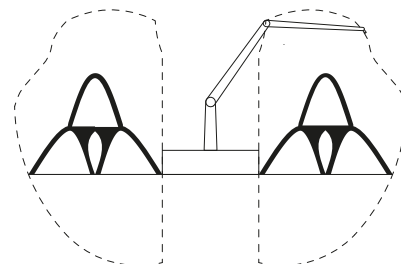
## Triangles

By constructing the levels as triangles, a structure is created where the bottom levels align with the top level to better support it. This adds another bottom level chamber without adding that much material overall.



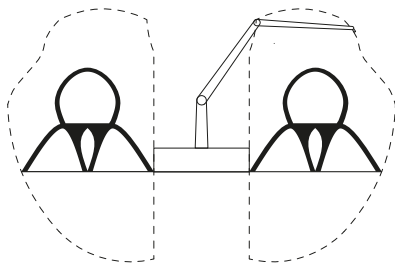
## Curved Triangles

To get more volume out of the structure the triangles can be reshaped a bit and add hollow parts in the core where piping, ventilation or plumbing could be fitted.



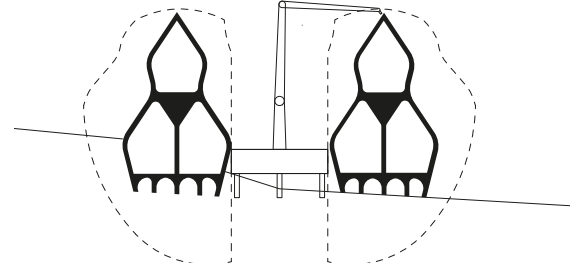
## Asymmetrical Curved Triangles

By making the structures more asymmetrical the size of the hollow space in the core is increased, but the second level also loses some of its width. This solution has less overhang than the previous proposal and would likely be easier to print.



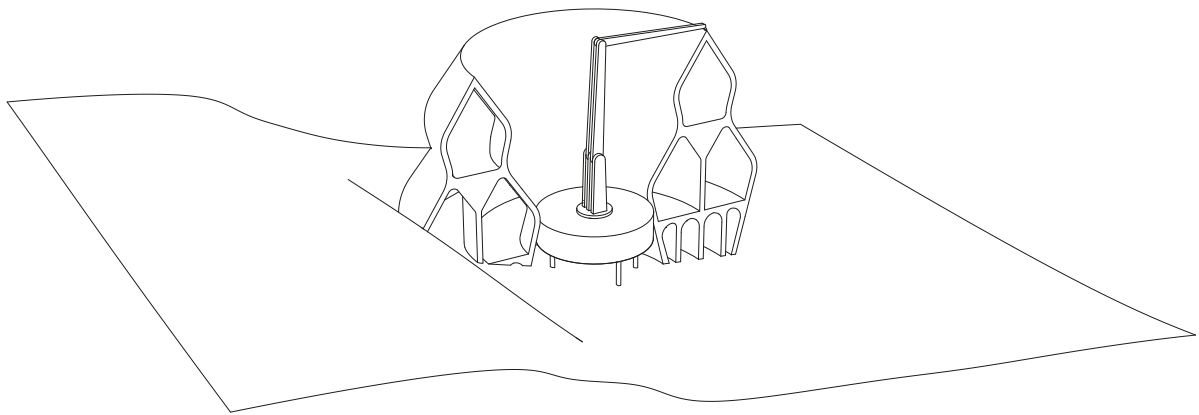
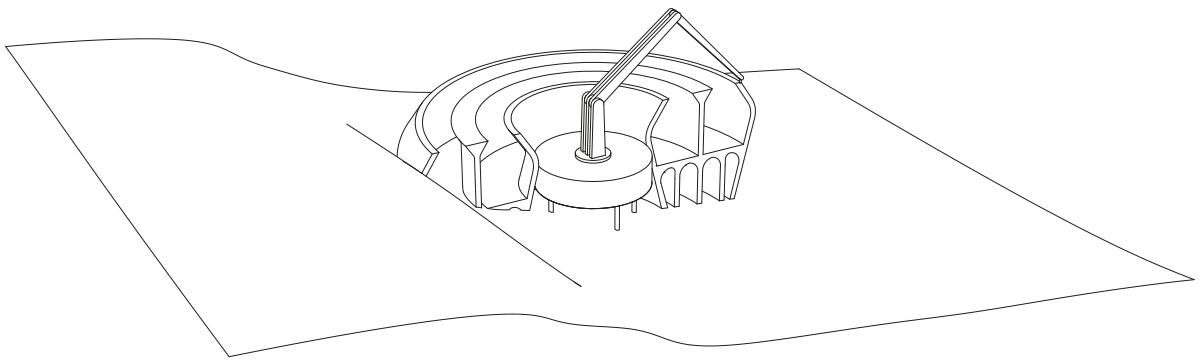
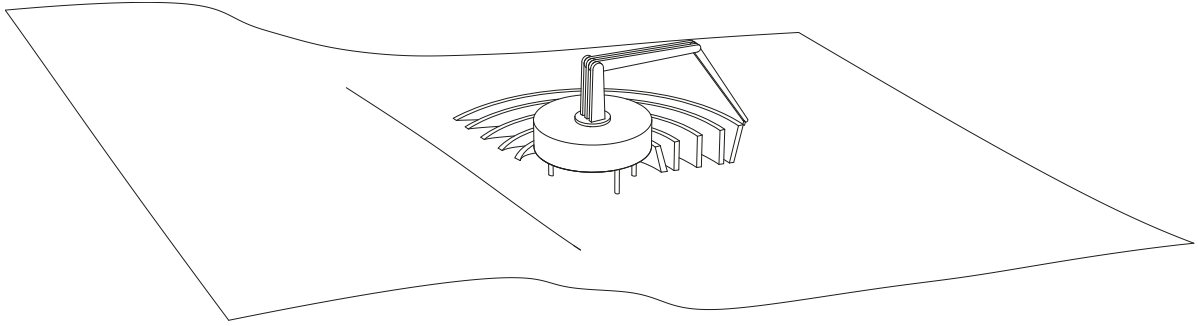
## Ballooning upper level

The second level however doesn't necessarily need to have the walls tilted inwards, instead second level could be shaped cylindrical and get more volume out of less material. The upper level does have a lot of overhang, and the outer walls on the bottom levels are not very practical to print.



## Ballooning Levels

The expanding logic can be applied to the first level as well. To better support levels above, the spaces are made in a tear-drop shape which increases the load carrying capacity. The walls become more vertical and more practical to use.



This design allows for more useful volume than the maximum volume design does. It also reduces the amount of printed material needed and allows for the building to adapt to the surroundings within the same design.

A stair can be added inside using the same design language and in a steep hill one of the chambers can be removed to still allow the habitat to keep its design.

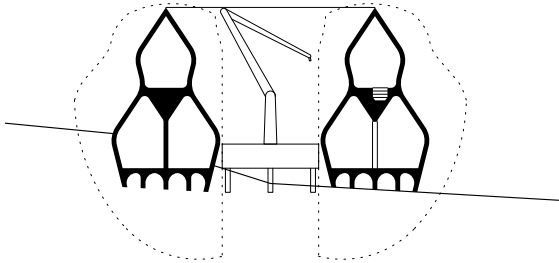
Each level has a high ceiling that allows the floor of the habitat to adjust to differenc-

es in elevation without changing the base structure radically.

One problem with the maximum volume model is that it has an almost flat roof and in order for the printer to print stable structures they need a lot of vertical support from below.

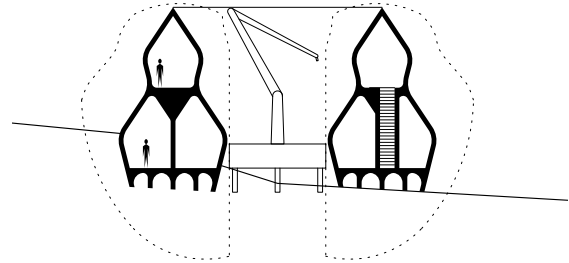
This model addresses that issue by not printing anything walls angled more than 40 degrees from the vertical.

# HANDLING ELEVATION



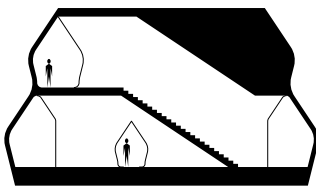
## Opening bellow the stairs

When adding a second level to the structure it also needs to allow the astronauts to move between the levels as well as between the chambers.



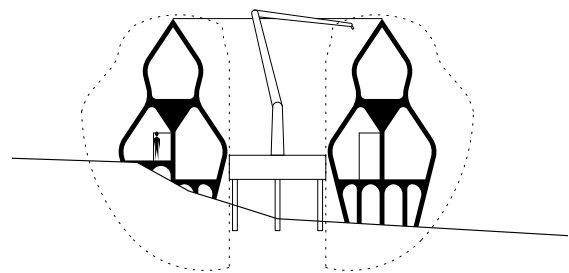
## Stairs

In order to build a stair that is still supported from below when printing the stair is designed to be integrated into the existing walls.



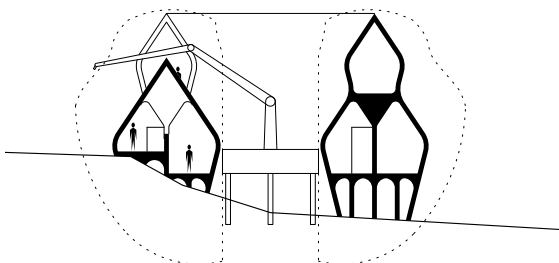
## Section of stairs

To allow users to move between the two different chambers on the bottom level, vaults are made through the middle wall. The same shape that is used for the chambers is used for the vaults connecting them.



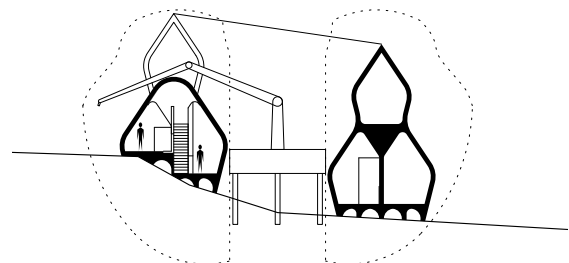
## Chambers adjust to elevation

When dealing with elevation differences in the terrain there are a couple of ways to handle them. One method could try to have the arm excavate an area for the habitat like is seen in the previous models, or the design could let the habitat adjust to the elevation.



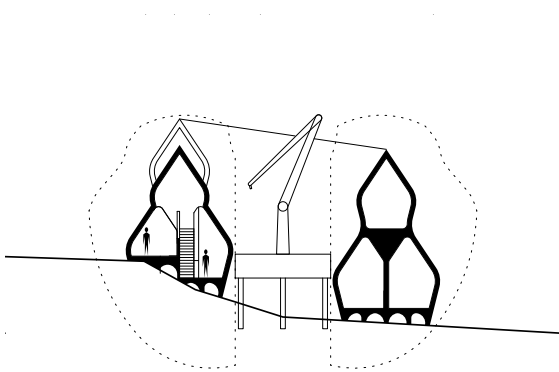
## Habitat shape adjusts to elevation

If the elevation differences become too large for the floor of the first level to adjust without hitting the ceiling, the second level can be removed over those parts.



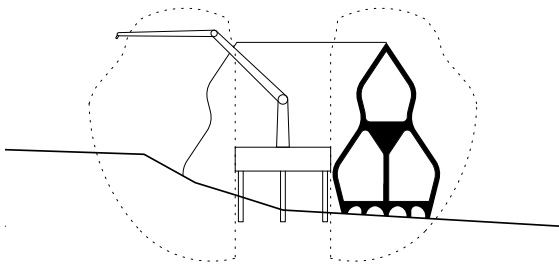
## Habitat functions adjust to elevation

Allowing the habitat to move with the elevation, the stairs could be strategically placed so that they lead from where the first level is at its highest towards where the second level is at its lowest.



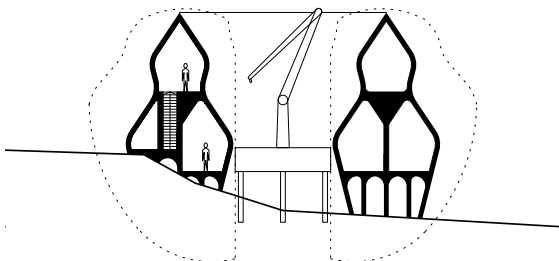
### Changing elevation in Chambers

When having floors that move with the elevation the question of how to move the floor arises. Making the floor into one big ramp that follows the terrain is possible, but impractical.



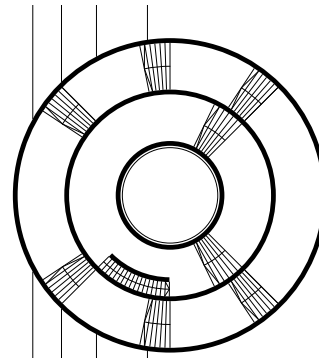
### Structure ends at elevation

By instead creating a flat floor and end the structure wherever the elevation of the ground gets higher than the floor, the design trades a simpler structure with a smaller footprint for some built area. This is a smaller but more effective habitat.



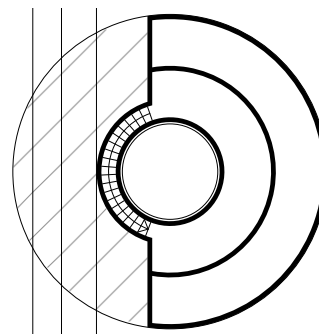
### Minimising internal elevations changes

By raising the floor to the same level as the bottom of the printer and let parts of the habitat stand on legs, like in the earlier sketches, the area that is cut away by the elevation is significantly reduced.



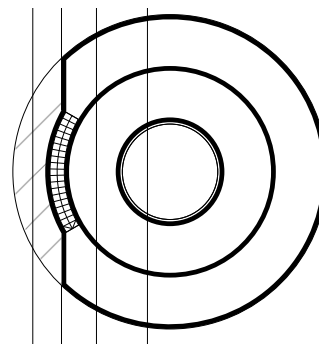
### Plans with stairs

By adding stairs to a plan of the habitat that would allow the floor to remain flat while still following the terrain, it is apparent that the habitat is filled with stairs. This takes a lot of floor space and limits the usage.



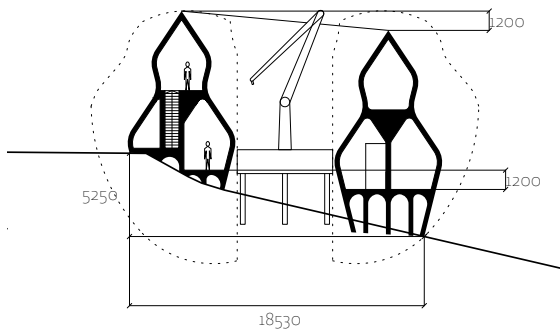
### Plans when ending at elevation changes

This example shows that if this method is implemented and construction is started at the lowest practical elevation almost half of the habitat is lost. This example gives less floorspace than building stairs but uses less material.



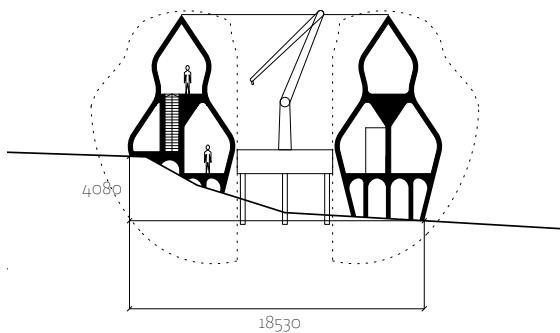
### Plan when minimising internal changes

The plans show that only a fraction of the built space is cut off by the rising elevation, and this area could actually still be partly used by placing that stair between the first and second levels here.



By trying to determine the steepest slope that can be built, there are a few factors that affect the result. Most influential is the base of the printer as the already determined limits of the arm are based on the arm and not on the surroundings. Lowering or raising the base of the arm affects the reach of the arm.

In the example to the right high parts are printed to the topmost extent of the printer, and the lower parts are printed to where the legs reach the limits of the printer. This gives an insight into the limits imposed by the elevation.

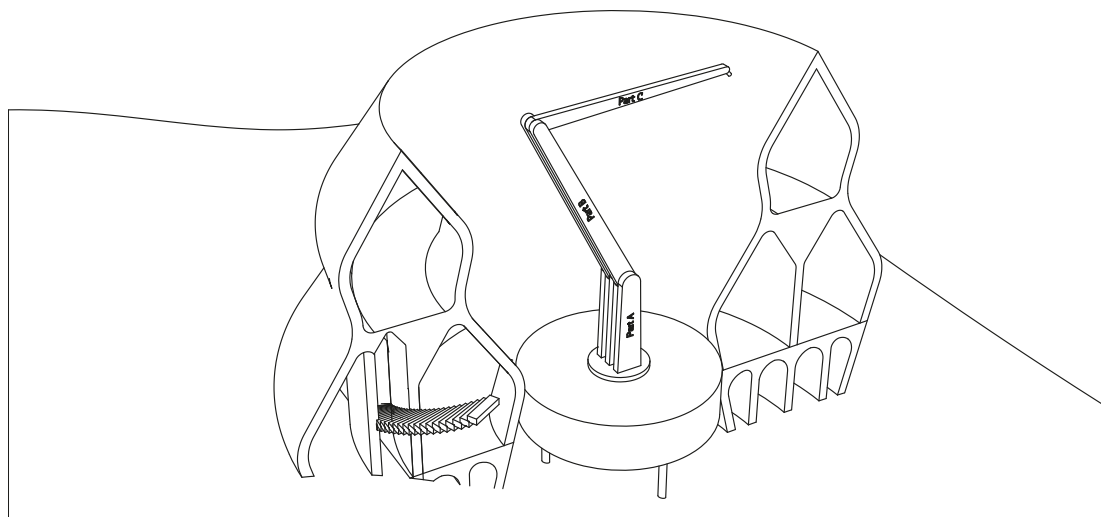


But to keep the floors level however, slopes as steep as pictured above cannot be used, as that would force the floor to be raised to follow the terrain.

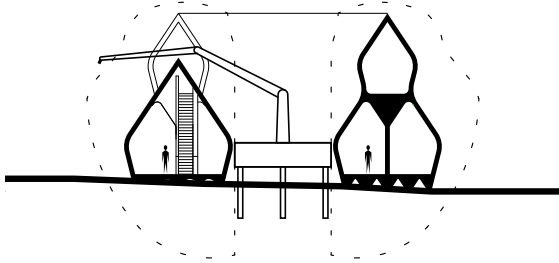
To the left is an example of how the habitat can handle elevation changes while still keeping the floor level.

The diagram shows that the legs of the habitat can be expanded up and down 3 meters and still allow for a level floor. The outer chamber can go higher on the side with the stairs.

Figure 1 *Level floors in slope*

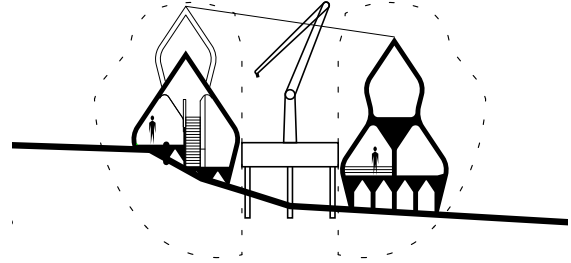


3D Visualisation of a cutout of a habitat standing in a slight slope.



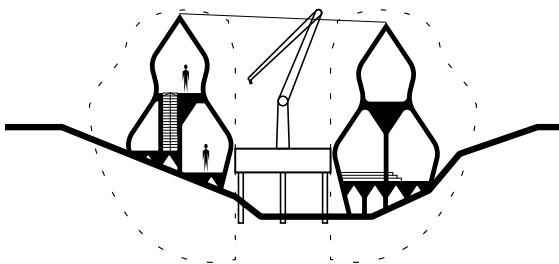
### Flat Ground

When printing on flat ground the mission might require one larger room and skip the second floor on parts of the habitat. This would also allow the arm to function as a crane and lift experiments in and out of the habitat.



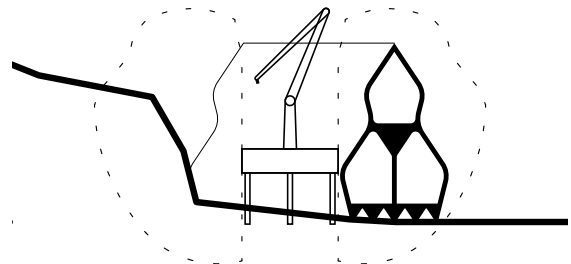
### Printing in slope

When printing in a shallow slope it might be worthwhile to let the stair to the second level to move from the highest elevation towards the lowest and thus reduce area used by the stairs.



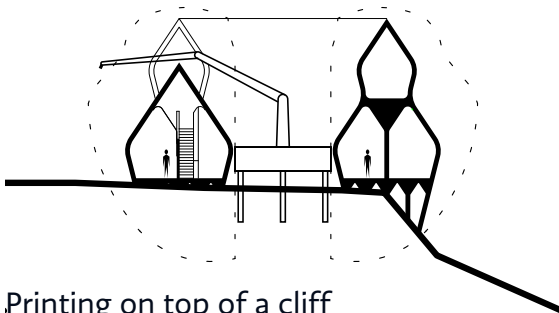
### Printing in craters

When printing in a depression the "legs" can be used to take care of some of the elevation changes, and also let the stairs go over other areas with steep elevation to make use of space that would otherwise be wasted



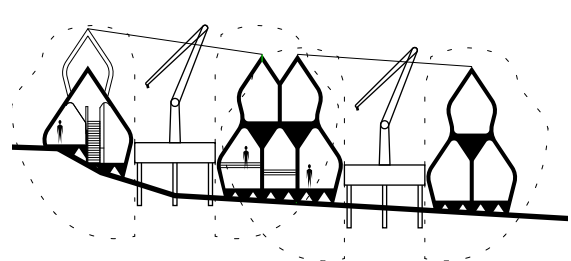
### Printing below a cliff

When printing next to a cliff the printer might be unable to print the entire circle around itself and would then only print a "horseshoe".



### Printing on top of a cliff

When printing on top of a cliff the legs can be extended to stabilize the structure.



### Combining habitats

If needed, two printers next to each other could work together to build two interlocking circles.

# MATERIAL AND EFFECTS OF PRINTING METHODS

## Layers of additive manufacturing

When 3D printing each layer is stacked on top of the previous, and this invariably leads to some distortions.

Using small printer nozzles and extruding less material means that these distortions and imperfections are smaller, but it also adds time to and energy to the construction.

Larger nozzles and extruding more material lead to less even surfaces and larger imperfections.

Test prints have been made to simulate printing in a regolith/PLA mixture, and to the right we can see two examples of the printed results.

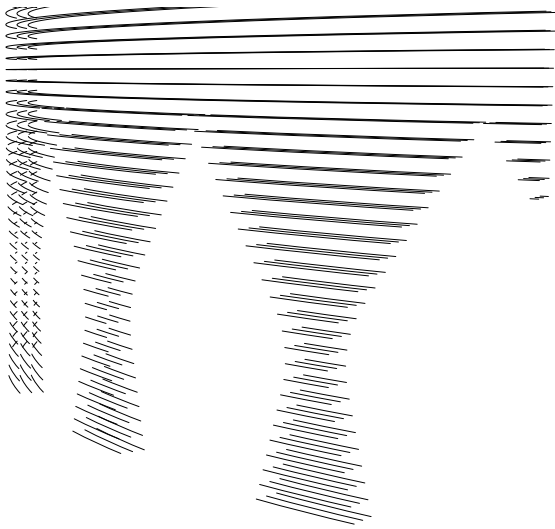
It's worth noting that since the gravity will be different on Mars the final print will likely behave differently from this. With lower gravity we can expect less compression under the materials own weight. We also expect less forces pulling the structure down, meaning that the material should "slump" less than on earth.



Figure 2. Printing Closeup (AI Space Factory 2019) Reprinted with permission.  
Test prints of a simulated regolith/PLA mixture by AI Space Factory.



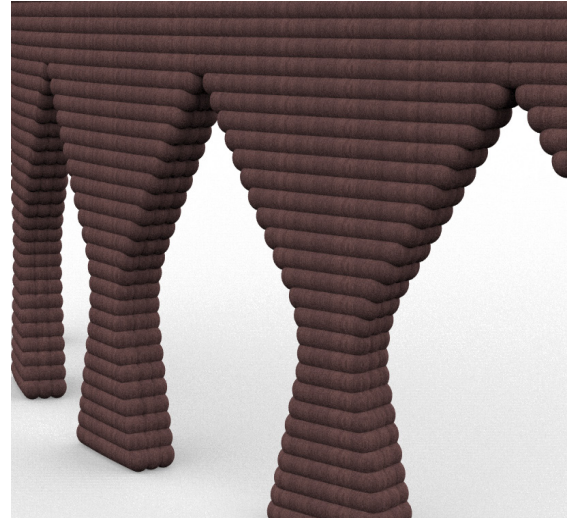
Figure 3. 3D Printing (AI Space Factory 2019) Reprinted with permission.  
Test prints of a simulated regolith/PLA mixture by AI Space Factory.



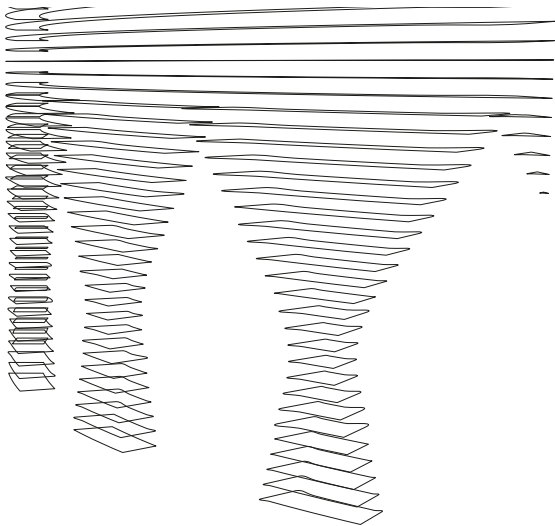
### Outside-in paths

There are several different ways of 3D printing the habitat and what method is chosen will affect the spatial experience inside the habitat.

Pictured above is the path the printer head will follow when printing from the outside and in.

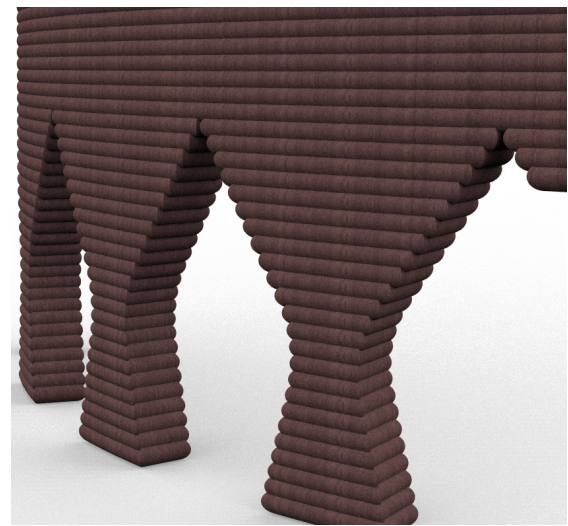


This method suggests that printer would just stop extruding where there are supposed to be openings, and continue again when the wall starts. It would start each layer the furthest out and rotate inwards before printing the next layer. This would create granulated tactility to walls and surfaces that are perpendicular to the curvature of the habitat as can be seen above.

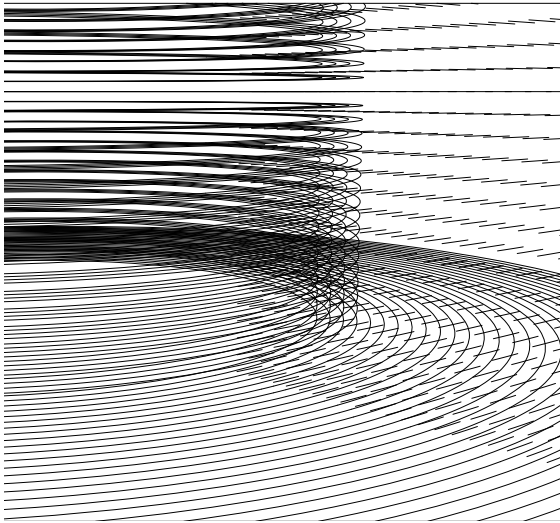


### Contoured paths

Another method is to print the outlines of these areas in one go. This would give smoother surface edges where the walls move perpendicular to the curvature. This gives the walls and surfaces a surface full of horizontal lines rather than a granulated surface.

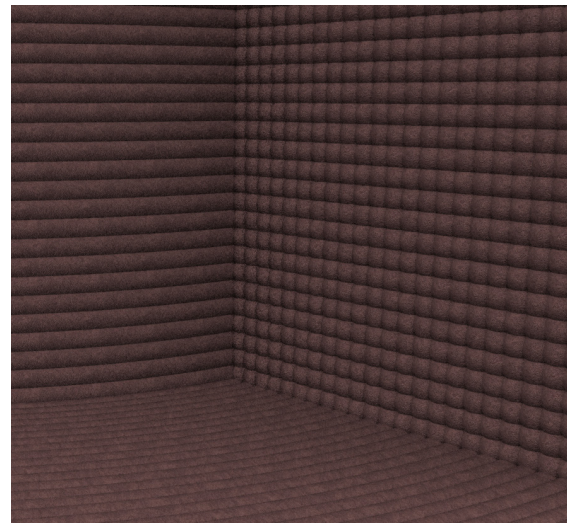


The method of printing the outlines as pictured above gives a more cohesive experience of the spaces, and also allows the walls to be more hollow, either to be used as storage, or to reduce the materials needed, and thus this option is deemed most appropriate to continue with in this thesis.

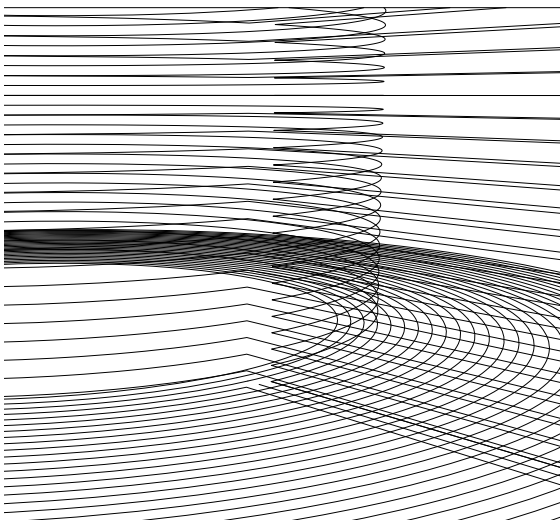


### Outside-in paths

The effects of these differences become more apparent when printing an entire wall perpendicular to the curvature of the habitat and not just openings in a wall following the curvature. In the example above we have once again applied a strict "outside in" approach to printing.

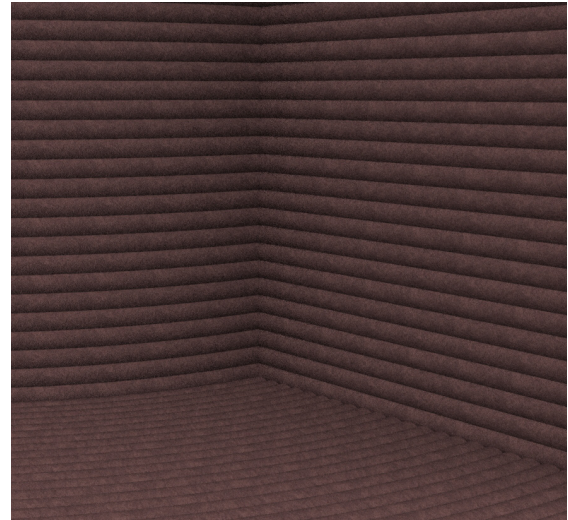


The wall perpendicular to the curvature become clearly granulated and gets a distinctly different pattern and surface tactility when compared to the walls printed along the curvature. This method gives form to two different expressions on the walls while still adhering to the same principles of design.

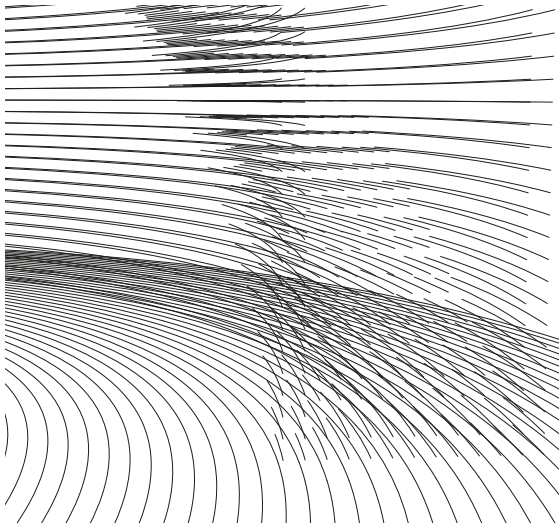


### Contoured paths

In the example above the printer follows a path along the surfaces instead of strictly following the curvature from the outside and in.

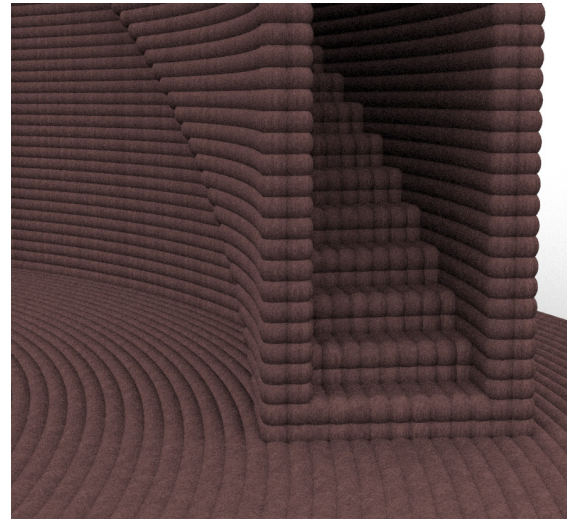


This gives all walls a more cohesive appearance and allows the pattern to continue throughout the habitat. The textures in the floor will still, assuming they are not covered by further installations, still give an indication of the direction of the direction in the habitat.



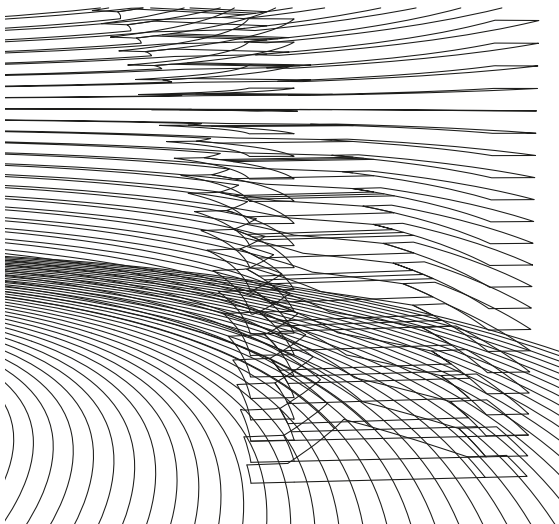
### Outside-In Printer paths

The choice of whether to design with a purely "outside in" approach or following the surface doesn't affect the function of the openings in walls or the walls themselves, but it does however limit the design of the stairs.



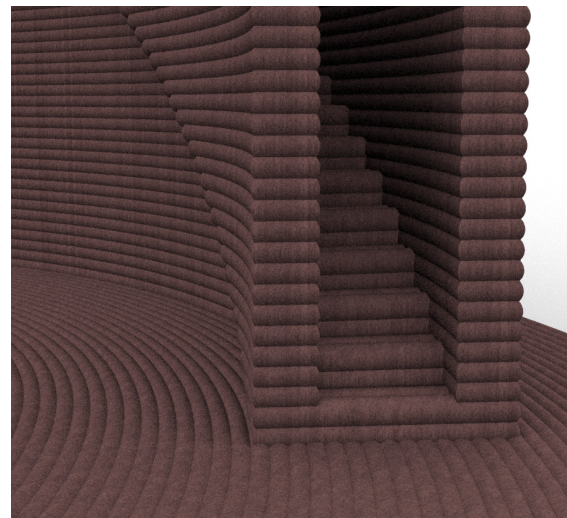
### Outside-in printed visualisation

Since the printer head moves with a spacing of 100 mm this means that the design with the 'outside-in' paths is restricted to increments of 100 mm in width of the design, but have a freedom in depth.



### Contours Printer path

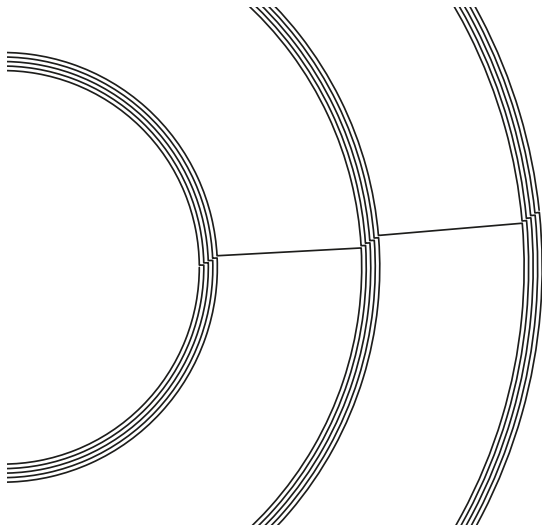
The design following the surfaces on the other hand is restricted in the depth of the steps but allows for a free form in width.



### Contours printed visualisation

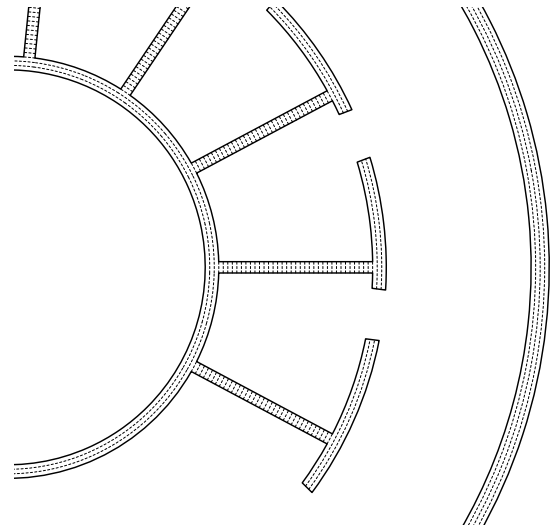
The choice in design also affects the physical experience of walking in the stairs as the shape of the footing will change significantly unless some sort of flooring is added.

# PRINTING PATHS



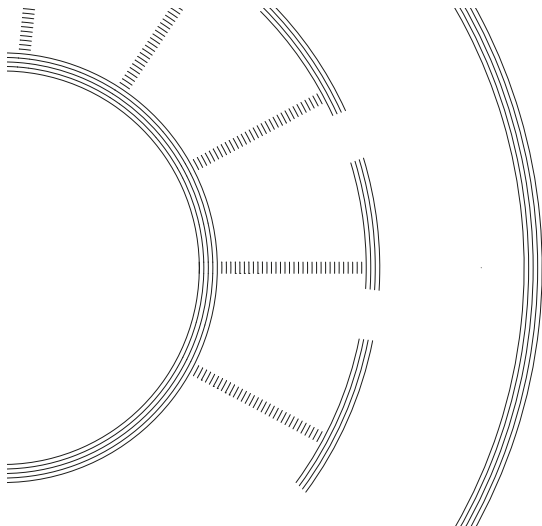
## One Path, outside-in.

One way of printing is having the printer make one continuous path and print the next over it. This method has the upside of having few starts and stops which reduces the risk of spillage or unintentional gaps in the print, but it also puts limitations on what the habitat can contain. This is even further complicated by the "outside-in" rule.



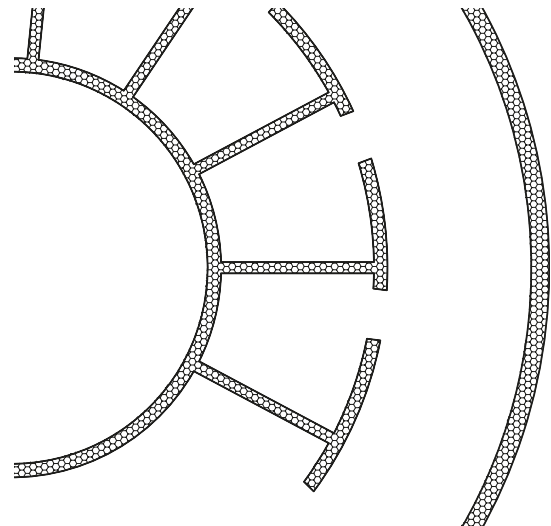
## Contours, outside-in core

The volume chosen to continue with is well within the limits of the arm however and there is no risk of the arm hitting what has already been printed as long as we work in layers. This opens up for paths where the core has a continuously printed outline.



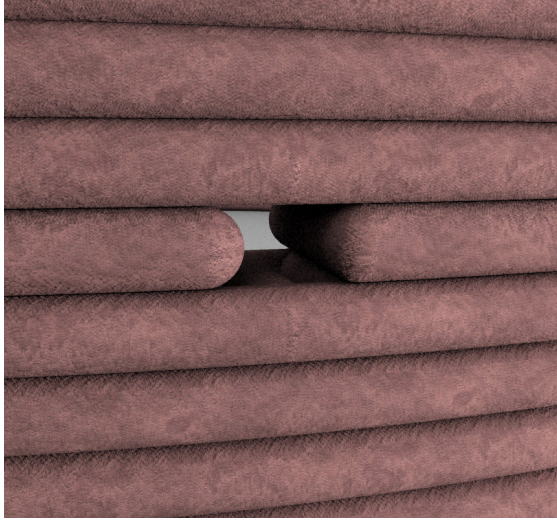
## Discontinuous paths, outside-in.

In contrast to a continuous line another alternative is to slice the volume up in circles and just let the printer work "outside-in" circle by circle until the layer is printed and then do the same with the next layer. This would follow the "outside in" rule established when trying to find the furthest printable reach of the printer



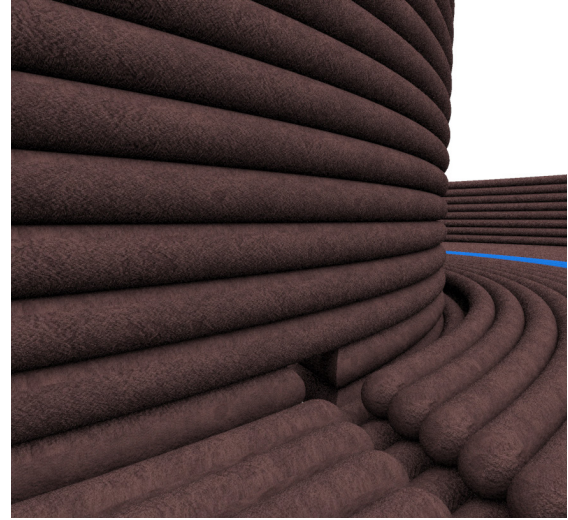
## Contours, hexagonal filling

If we can print an outline, we can also experiment with the core. A "honeycomb" pattern inside is proven to be one of the strongest and most material efficient ways of filling strictures. This does however limit our ability to put piping cables through the walls.



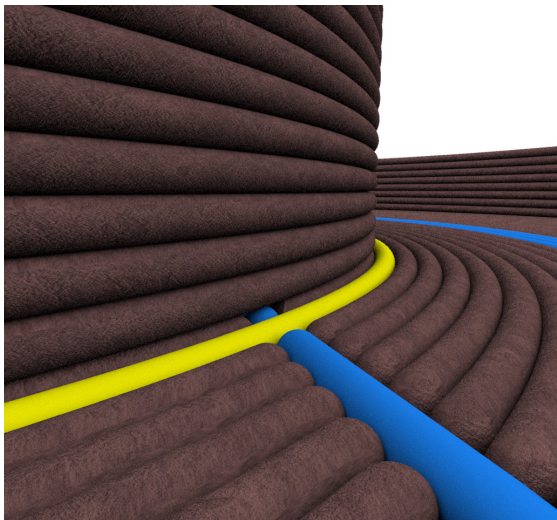
### Installations between rooms

In order to make space for plumbing, electricity, lighting and other necessary infrastructure within the habitat paths can be printed through the walls. The example above has a width of 8 cm, the same as the printer head, and can thus be filled easily.



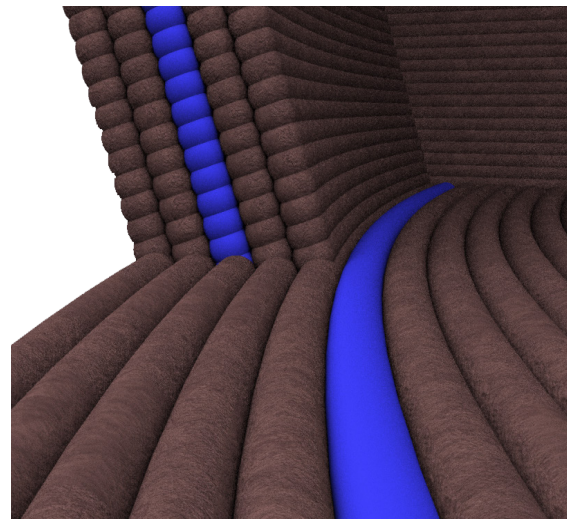
### Installations in floors

Here one revolution of the floor print has been removed next to the hole allowing the infrastructure to be integrated into the floors.



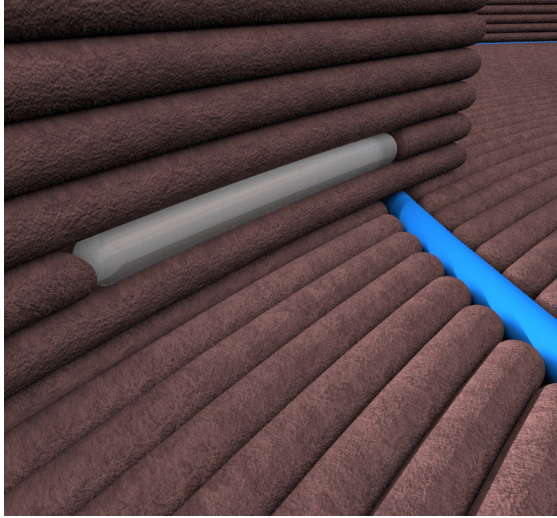
### Integrated infrastructure

If we design the plumbing and electric wiring to come in 8 cm wide tubes, we can integrate them into the floor as illustrated here with yellow and blue tubes for electricity and plumbing. The yellow electric cable can also be seen moving through the wall in the hole previously mentioned.

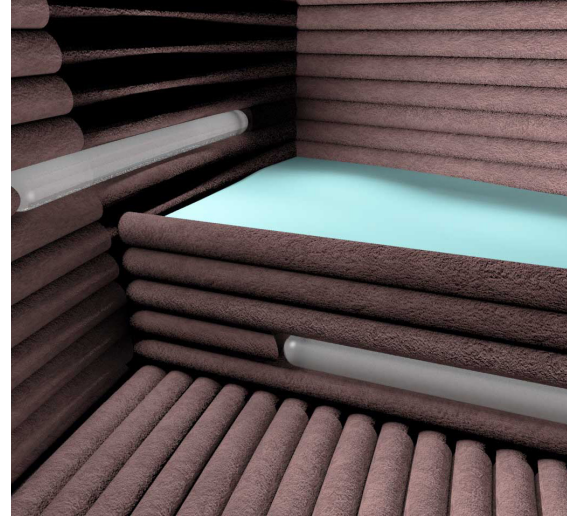


### Integrated storage and shielding

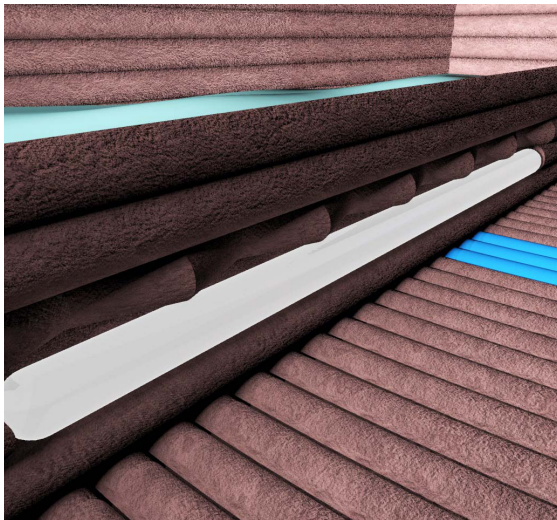
Since the pipes have the same dimensions as the printed paths, pipes could be integrated into the walls for storage. Putting water storage inside the outer walls would allow them to both store a large amount of water and also act as a radiation shield for the humans inside the habitat.



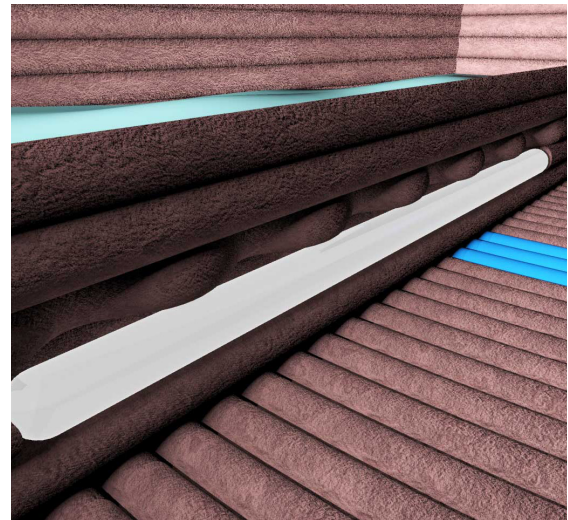
With a standardised shape and system for installations the same logic is applied to other installations as well. In the render above a lighting fixture has been implemented into the wall close to the floor shining a light on the water pipe.



Similar fixtures can be implemented in the individual crew quarters. Pictured above is a render of a prototype bed with a headlight and a light close to the floor to light the way for the inhabitants.



In order to ensure that the layer above the fixture doesn't slump when being printed, a wave pattern is printed above each of the fixtures. This wave pattern allows the layer to be supported by the wall inside of the fixture while still supporting the layer above, printed in the walls regular path.



Aside from filling a structural function, this detail also affects the lighting conditions within the habitat. The sharp edges in the render in the bottom left consequently makes for sharper contrast while the more curved waves of the render in the bottom right has smoother differences in lighting. Aside from this printing sharp edges using an extruder is challenging, thus a set of curved waves is preferable.

## ROOMS AND FUNCTIONS

In the end, the habitat is after all designed to be used with a purpose. This is meant as humanity's first presence on Mars. And it's a scientific presence with scientific goals.

Genta (2017) writes that a functioning habitat would need the following functions:

- A galley or kitchen
- Individual crew quarters
- Meeting and communal spaces for social gatherings, dinner, and recreational activities
- One or more laboratories
- Workspaces
- Greenhouse
- Hygiene facility
- Medical facility
- Storage spaces
- Space for the life support system
- Airlocks, and/or hatches
- A solar storm shelter

In addition to that this particular habitat will need some sort of method of moving between the levels of the habitat, and moving between the chambers on level one.

One of the goals of this thesis was to find ways of integrating these functions into each other in a closed recyclable system.

In order to achieve this all functions are mapped as nodes and connections, where functions, or nodes in this case, are connected to other nodes it can interact with.

Examples of this is that the kitchen/galley should be close to the communal room for dinners, which in turn could benefit from being connected to the individual crew quarters.

Some nodes were very connected to many other functions, and some only a few, while some were omnipresent, like the life support.

The functions can be divided into primary and support functions.

As an example, there is a total storage need that can be calculated and be presented as one function, but it's mostly there to support other functions like the kitchen, the medical bay, or the workspaces.

By categorising storage as a support function, the storage needed can be expressed as storage needed to support a function.

By mapping the divisible support functions these function nodes are changed into integration nodes and the connections indicate where functions can be integrated into each other.

There are also functions that act like both primary and support functions, like hygiene and communal spaces. Hygiene has a function on it's own, acting like a bathroom or shower, but also a support function in for example cleaning instruments in the laboratory.

The primary functions are:

- Workspace
- Laboratory
- Medical Facility
- Airlock
- Kitchen
- Greenhouse

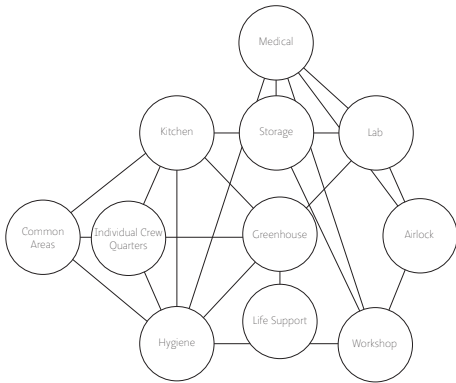
Support functions are:

- Storage

Hybrid functions are:

- Individual Crew quarters
- Hygiene
- Communal spaces
- Solar storm shelter

In addition to this, life-support is an omnipresent function that needs to be connected to all other functions.



### Mapping functions and connections.

Of these functions some have predetermined locations within the habitat. The greenhouse is located in the middle under the water-filled dome, and the airlock needs to be connected to the outside.

Primary functions



Support Functions



Omnipresent Functions

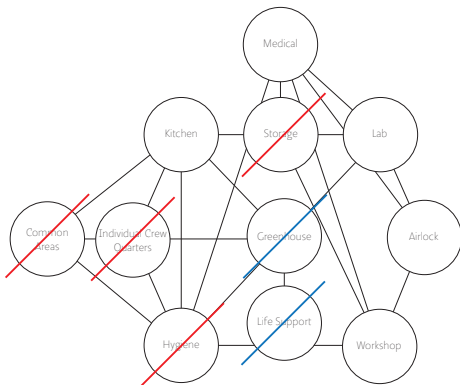


Hybrid



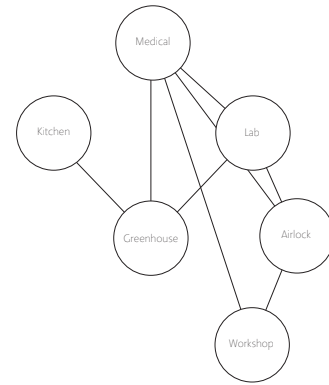
### Categorizing Functions

Functions are organized as primary functions, support functions, Hybrid functions or Omnipresent functions.



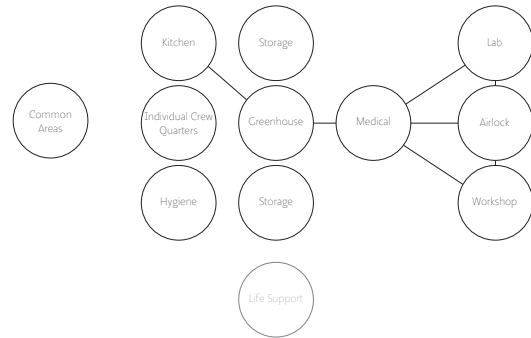
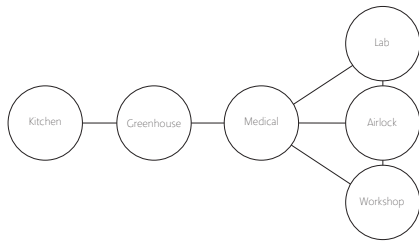
### Culling

Crossing out support functions or hybrid functions leaves a map of what primary functions should be connected.



### Primary functions and connections

This map shows the primary functions and their connections.

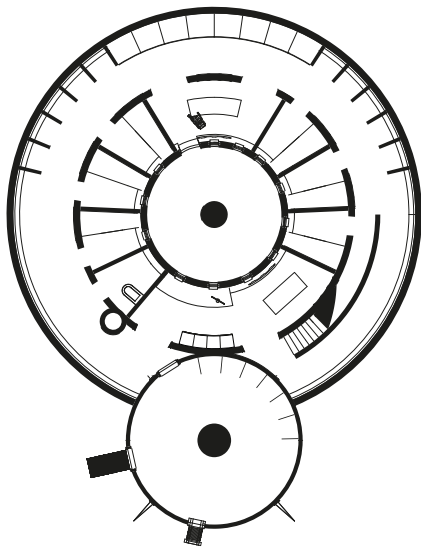


### Arranging primary functions

Rearranging the functions show clustering of functions related to "work functions". Lab, Workshop, Medical Bay and Airlock on one side, and the kitchen on the other.

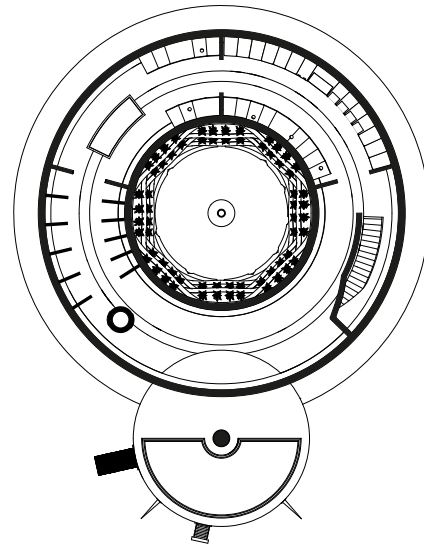
### Reintroducing functions

Reintroducing the other functions shows where different functions can be positioned. Storage acts as connections between functions and functions without connections can be rearranged more freely.



### Plan level 1

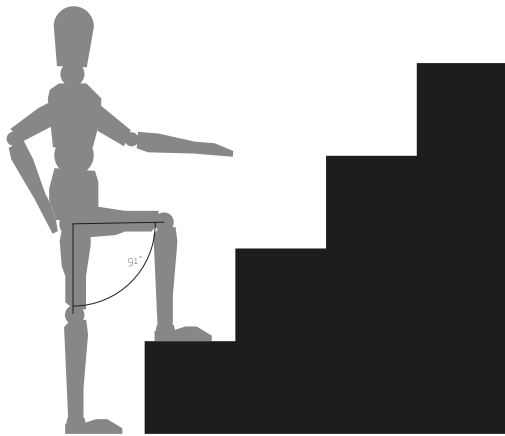
Based on the mapping of functions, this floor plan was designed. The individual crew quarters are arranged around the greenhouse in the middle, with a view into it. The kitchen and dining area in the middle of the "living area". Storage corridors connect to Medical Bay and airlock in the bottom.



### Plan level 2

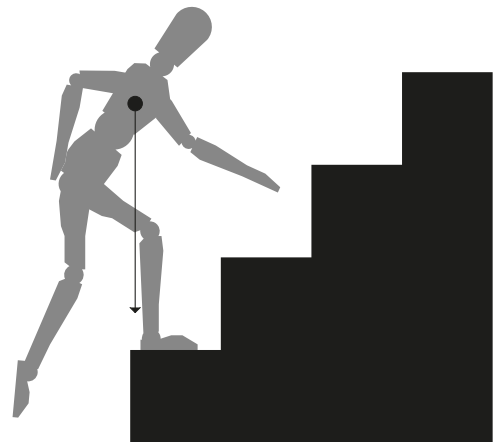
The lab and workshop are located on the second level, connected to the airlock and medical bay through the stairs. They share a storage area.

# STAIRS



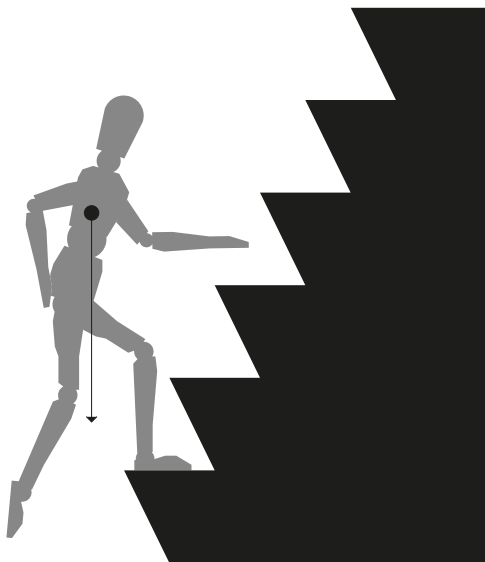
## Large Steps

With lower gravity on Mars than on earth, allows humans to traverse vertically easier than on earth, which in theory could allow for new types of stairs. One such type could be with larger steps. Which would force the person to bend the knee further with each step.



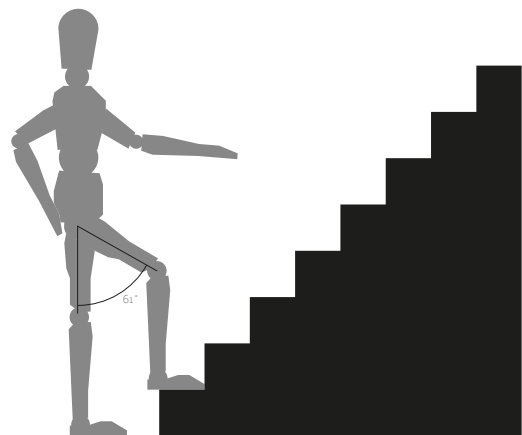
## Balancing Centre of Mass

The new height also means that in order to balance the centre of mass above the supporting leg, the person would have to bend over further.



## Steep Stairs

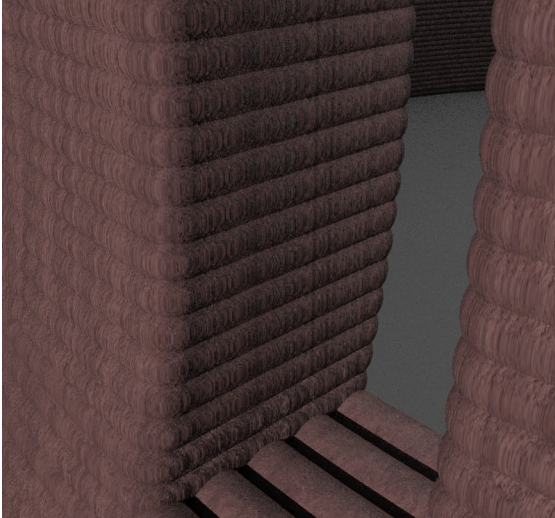
If we instead tried to make the stair steeper, the same problem with the centre of mass appears. The person would need to use the arms in order not to fall backwards when climbing the stairs. This in turn would prohibit the person from carrying anything between the levels.



## Combinations of stairs

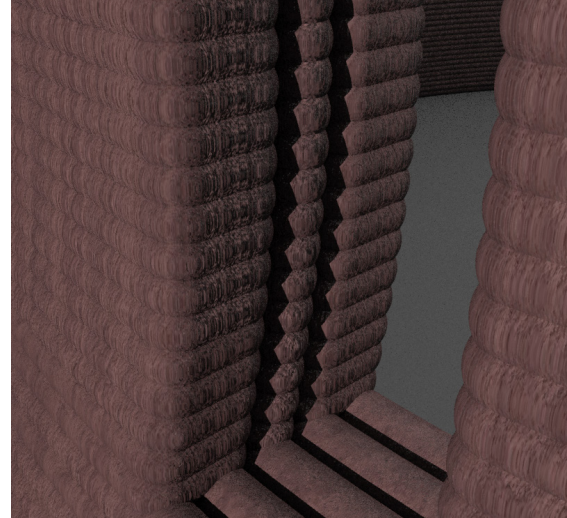
It would appear as if though it's the human body rather than the gravity that is the key factor in finding the best type of stairs.

## WINDOWS AND OPENINGS



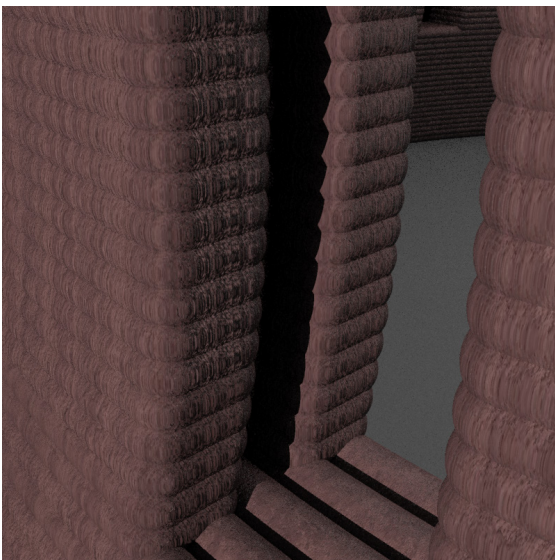
### Contoured Paths

Pictured above is the opening for a window created following the "contoured paths" printing method described previously on page 53. This opening is not optimised for installing windows or other installations that need to go in the opening.



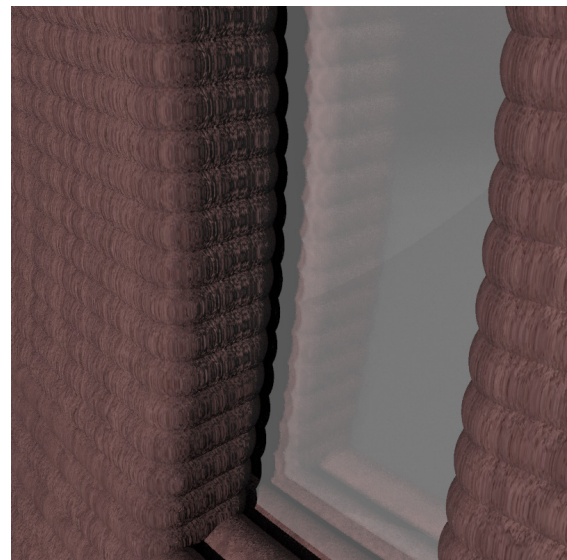
### Contoured and outside in Mix

Pictured above is an opening where the contoured paths print is mixed with the outside in method in a 2+1+2 pattern where the outermost two paths are printed as contours while the middle path is printed as an open curve.



### Offset middle curve

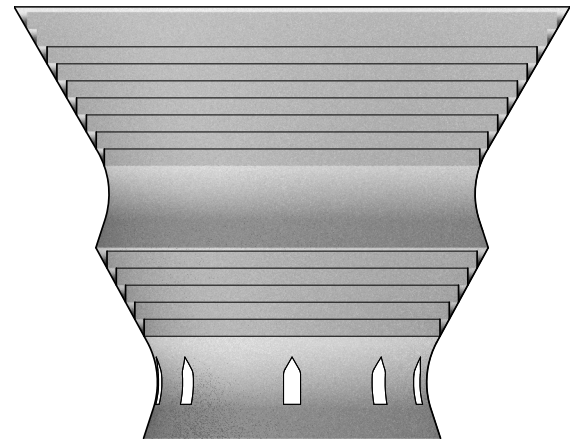
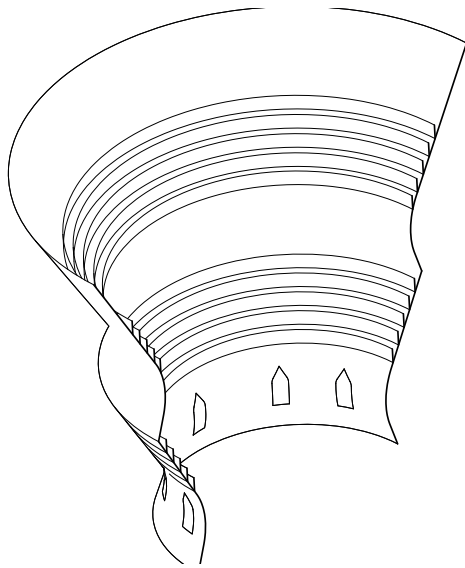
Taking the 2+1+2 system the open curve in the middle is offset in order to create an opening where installation frames can be placed.



### Installed window

With the 2+2 system illustrated to the left, a window can be placed in the opening. Using an inflatable frame, the window is then fixed in place and sealed by the inflated frame.

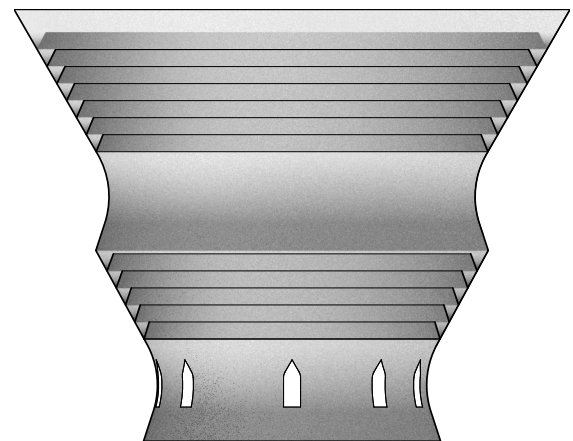
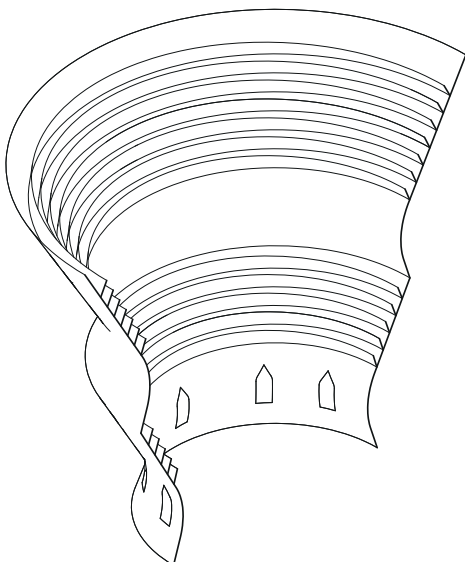
# VERTICAL GARDEN



## Straight Sections

In order to get more garden space out of the greenhouse vertical gardens will be implemented. The first iteration of the gardens had terraces created by printing a 400 mm high wall straight up from the surface of the habitats greenhouse walls.

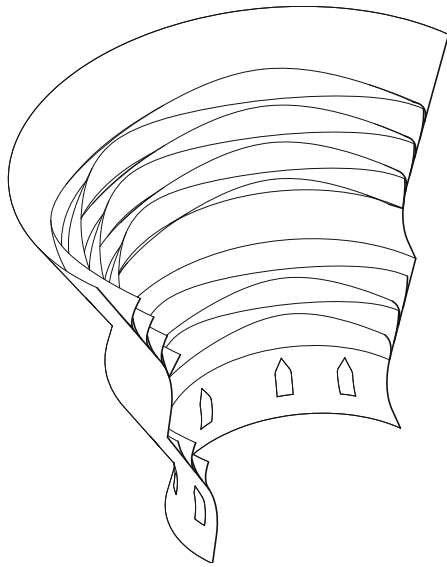
This creates seven terraces on the upper part and five on the lower part. These terraces can be filled with manufactured dirt and be used to grow different plants inside the greenhouse.



## Outwards leaning sections

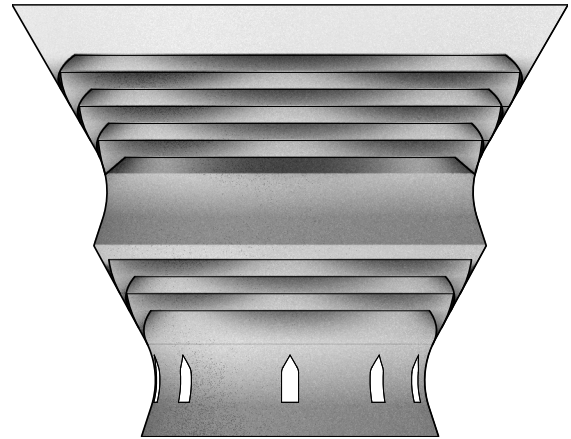
In order to allow for a more plants and crops, the second iteration of the vertical garden has the printed walls tilted inwards towards the centre of the greenhouse. This gives the greenhouse almost double

the area to grow plants and crops on compared to the first iteration. It does however slightly shade the levels below, and given that the sunlight is already much weaker than on earth, the plants are likely to need artificial light to grow.

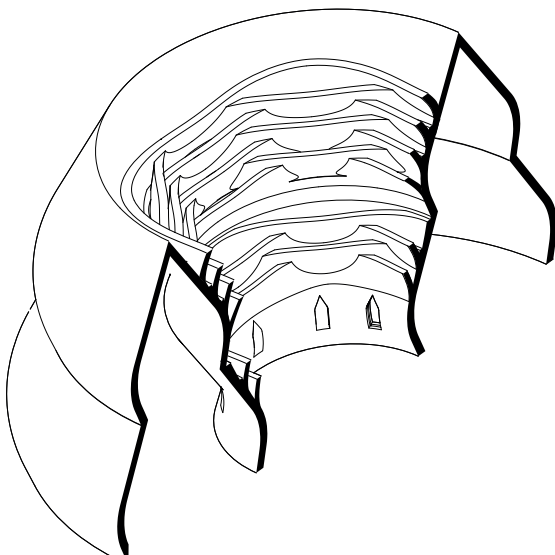


### Curved and leaning sections

In order to attain a more variable shading of the terrace levels the third iteration varies the depth of the terraces. Like how the first layer above an installation was curving in and out in order to get support for the layers above, the terraces curve in and out to build support for where they are the widest.

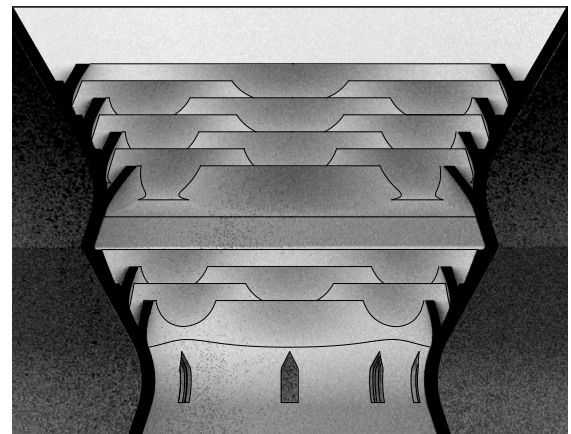


This gives them a more organic appearance which serves a third purpose. Aside from helping feed the astronauts and help purify water and air, the greenhouse is also a reminder of home. It's intentionally organic as a contrast to the very pragmatic design of the rest of the habitat.



### Final Garden

The final iteration integrates the terrace levels with the walls of the habitat. At the bottom the, a mobile platform can be attached to the docking port that remains from the construction in order to allow the astronauts to harvest and work the higher platforms as well as the lower ones. The platforms are printed as part of the habitat walls and are



filled with soil created on site. Nelson et al. (2008) suggest that it's possible to grow crops in a closed system using regolith and bio-waste accumulated during the voyage from Earth to Mars. Caporale et al.(2020) suggest that a mix of 70% regolith and 30% bio-waste could sustain crops in the greenhouse.

## RESULTS

The purpose of this theses was to present an architectural concept for a Martian habitat that the first humans going to Mars will live in.

This thesis has explored and presented options that are available to us as architects when printing with a specific 3D printer on Mars.

It has explored and demonstrated some of the effects of different methods of printing the habitat and how prefabricated parts can be integrated into an in situ-built habitat.

It has also tested and shown how different designs could affect everyday life in the habitat and how different functions could be experienced.

Further it has submitted a novel describing the life of the astronauts in the habitat that explores the everyday life and puts the effects and symbolic values of the architecture in the spotlight.

It has attempted to explore and present ways to integrate the envisioned research and safety needs with the printed structure.

As the thesis explores the results of a 3D printer with specific dimensions it should be noted that another printer with other specifications could print other shapes.

It should also be noted that in order to reach the desired level of detail, several options have been left unexplored.

There are countless possibilities and if the aim had been to pick the best option for every level of detail the thesis wouldn't even be able to pick the type of 3D printer.

Instead the thesis has presented a number of options to explore, explored them, and gone further in detail with one of the op-

tions and repeating the process in iterations of varying levels of detail.

The thesis has also explored ways of combining in situ-built parts on Mars with parts built on Earth and brought to Mars as well as ideas for how to manage resources on both planets.

This resulted in the habitat proposed in the thesis and a novel describing how the first astronauts reach the habitat and make it liveable for them, before giving the habitat over to another crew when returning to Earth.

In addition to exploring what the printer can print and how that affects the habitat, the thesis also proposes a number of ways of integrating technical solutions into the architecture of the habitat, such as radiation shielding by placing the water tanks inside the outer walls.

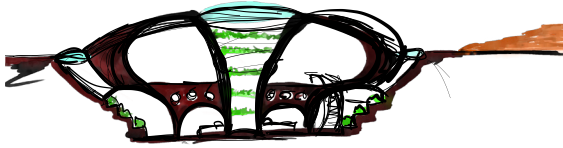
Aside from proposing a design for a Martian habitat, the thesis can also act as a repository for different options available.

The final goal of the thesis was to create a vision, that grounded by realists could be achievable, while still keeping the architecture in focus.

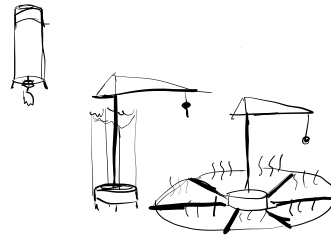
Therefore the final proposal has a focus on the architectural effects of the decisions made, rather than the technical implementations. How will the decisions made affect the way the rooms are experienced, how will the astronauts living in the habitat utilise the installations.

There is a huge interest in space exploration and the interest in going to Mars has perhaps never been greater than now, as such there are many different proposals. This thesis is just one of them.

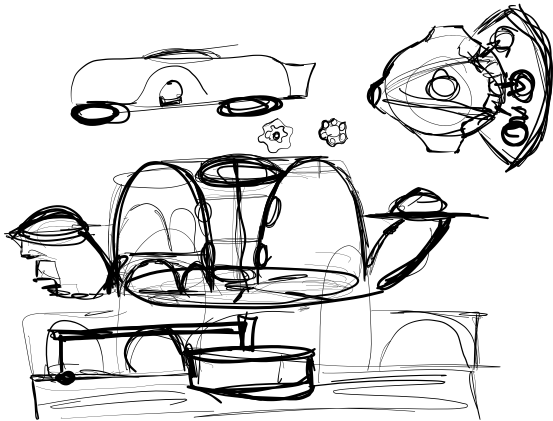
# EARLY SKETCHES



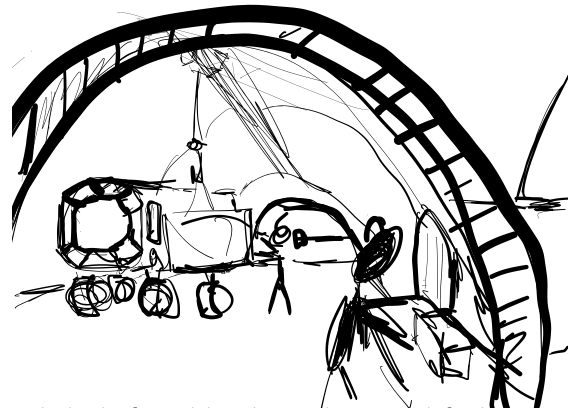
Early sketch where the habitat was built underground. Light channels were dug down to a subsurface garden in the corridor surrounding the bedrooms



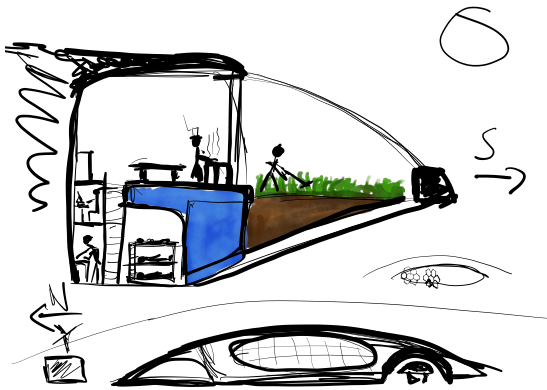
Early sketch of a 3D printing crane which would print the habitat on top of a heated pad to insulate the habitat. The reach of the 3D printer was deemed too short however.



Early sketch where the donut shape of the final proposal was implemented. The Printer design was vastly different and it would require a lot of digging

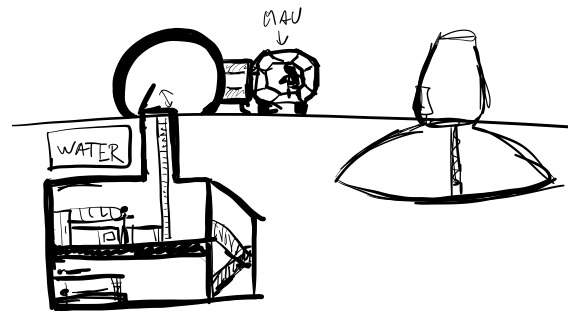


Early sketch of a workshop that was large enough for the MEV to drive into it. Deemed unrealistic for the initial missions however.

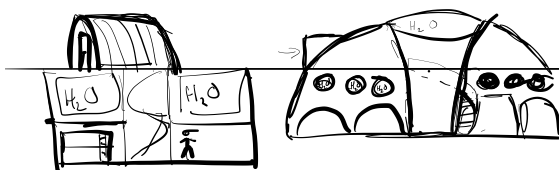


Early sketch of a habitat dug into a hillside. The living areas would be constructed below the water tank to shield from radiation while the greenhouse was under a roof. Water from the greenhouse would be filtered through the soils and brought back to the tanks. However, an automated method of constructing this habitat was deemed too complex to be explored in a Master Thesis.

Shelter



Early sketch of a habitat dug into the ground.



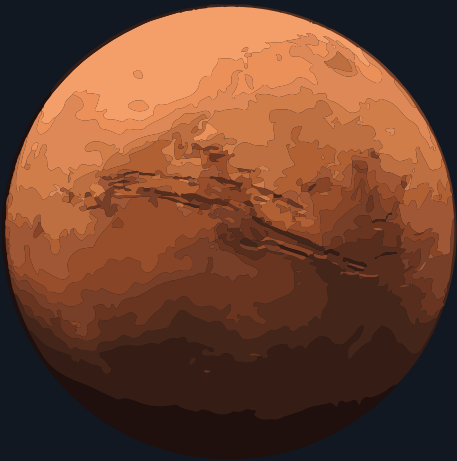
Early sketch based on survival shelters on earth. The crew would live underground below the water tanks with only the airlock above ground.



Early sketch of a habitat similar to the final design where the 3D printing arm would lift objects into an airlock for experiments, allowing the crew to move heavier experiments and equipment into the habitat.



## REFERENCES AND ACKNOWLEDGEMENTS



# ACKNOWLEDGEMENTS

Special thanks to the following people who helped make this thesis possible

**Annika Pihl**, who helped with the proof reading.

**Jonas Lundberg**, who supported the thesis plan and encouraged me to write this thesis in the Material Turn studio.

**Jonas Runberger**, who helped with the structure and direction of the thesis.

**Kengo Skorick**, my tutor who stayed positive even when I was at my most lost in the process.

**Larry Toups**, who helped give insight into what would be required from a habitat on Mars and what functions are needed.

# INSPIRATIONAL REFERENCES

**Chrichton, M. (1969)** *Andromeda Strain*. New York: Knopf

**Wier, A. (2011)** *The Martian*. New York: Crown Publishing Group

**Clarke, A.C. (1973)** *Rendezvous with Rama*. London: Gollancz

**Corey, J.S.A. (2011)** *Leviathan Wakes*. London: Orbit Books

**Donut House Mk.I (2015)** by A.R.C.H

**The International Space Station (1998)** by CSA, ESA, JAXA, NASA & Roscosmos

**Mars (2016 TV-series)**

**Marsha (2019)** by AI Space Factory

**Mars Habitat (2015)** by Foster and Partners

**Mars Ice House (2015)** by SEArch+ & Clouds AO

**Mars Science City (2017)** by Bjerke Ingels Group

**Mars X House V1 (2018)** by SEArch+

**Mars X House V2 (2019)** by SEArch+ & Apis Cor

**NASA Mars Habitat (2018)** by Arlbert Kahn Architects & Yates Industries

**Robinson, K.S. (1993)** *Red Mars*. New York: Bantam Books

**Squad (2011)** *Kerbal Space Program*, New York: Private Division Publishing

## IMAGE REFERENCES

**AI Space Factory (2019)** 3D Printing Closeup [Online Image] Retrieved from [https://www.dropbox.com/sh/hjyvuh-gueu1sloj/AAAo22l8RhU9ETaqoEa4L\\_\\_ua/2019-05-05-NASACHallenge/3-D%20Challenge%20Event%20Photography/Hi-Res?dl=0&subfolder\\_nav\\_tracking=1](https://www.dropbox.com/sh/hjyvuh-gueu1sloj/AAAo22l8RhU9ETaqoEa4L__ua/2019-05-05-NASACHallenge/3-D%20Challenge%20Event%20Photography/Hi-Res?dl=0&subfolder_nav_tracking=1)

**AI Space Factory (2019)** 3D Printing [Online Image] Retrieved from [https://www.dropbox.com/sh/hjyvuhgueu1sloj/AAAo22l8RhU9ETaqoEa4L\\_\\_ua/2019-05-05-NASACHallenge/3-D%20Challenge%20Event%20Photography/Hi-Res?dl=0&subfolder\\_nav\\_tracking=1](https://www.dropbox.com/sh/hjyvuhgueu1sloj/AAAo22l8RhU9ETaqoEa4L__ua/2019-05-05-NASACHallenge/3-D%20Challenge%20Event%20Photography/Hi-Res?dl=0&subfolder_nav_tracking=1)

**Discovery Hut and McMurdo Station (2008)**. [Online Image] Retrieved from [https://commons.wikimedia.org/wiki/File:Scott\\_Hut\\_and\\_McMurdo\\_Station.jpg#globalusage](https://commons.wikimedia.org/wiki/File:Scott_Hut_and_McMurdo_Station.jpg#globalusage)

## REFERENCES

- Adams, J. (2000)** Phoning Home from Mars in 2025. *Concepts and Approaches for Mars Exploration*, p. 1. LPI Contribution No. 1062, Lunar and Planetary Institute, Houston.
- Avakyan, S.V. Gaponov, V.A. Nicol'skii, G.A. Solov'ev, A.A. (2017, June)** Possibilities of the forecast of generation of the high energy solar protons for the safety of Mars Mission. *Acta Astronautica*, volume 135, 187-181 doi:10.1016/j.actastro.2017.01.030
- Canadian Space Agency (2018)** *About Canadarm2*. Retrieved 2020-05-28 from <https://www.asc-csa.gc.ca/eng/iss/canadarm2/about.asp>
- Caporale, A.G. Vingiani, S. Palladino, M. El-Nakhel, C. Duri, L.G. Pannico, A. Roupheael, Y. De Pascale, S. Adamo, P. (2020)** Geo-mineralogical characterisation of Mars simulant MMS-1 and appraisal of substrate physico-chemical properties and crop performance obtained with variable green compost amendment rates. *Science of The Total Environment*, 720 doi: 10.1016/j.scitotenv.2020.137543
- European Space Agency (2019)** *3D Printing our way to the Moon*. Retrieved 2020-05-28 from [https://www.esa.int/Enabling\\_Support/Preparing\\_for\\_the\\_Future/Discovery\\_and\\_Preparation/3D\\_printing\\_our\\_way\\_to\\_the\\_Moon](https://www.esa.int/Enabling_Support/Preparing_for_the_Future/Discovery_and_Preparation/3D_printing_our_way_to_the_Moon)
- Genta, G. (2017)** *Next stop Mars*. Switzerland: Springer International Publishing
- Goulas, A. & Friel, R. (2016)** 3D printing with moon dust, *Rapid Prototyping Journal*, Vol. 22 No. 6, pp. 864-870. doi: 10.1108/RPJ-02-2015-0022
- NASA (2017)** *The International Space Station : operating an outpost in the new frontier*. Houston, Texas: National Aeronautics and Space Administration, Lyndon B. Johnson Space Center
- NASA (2019)** *Solar System Exploration* retrieved 2020-01-21 from <https://solarsystem.nasa.gov/planets/mars/>
- NASA (2019)** *NASA's Treasure Map for Water Ice on Mars* retrieved 2020-01-21 from <https://www.nasa.gov/feature/jpl/nasas-treasure-map-for-water-ice-on-mars>
- NASA Space Science Data Coordinated Archive. (2018)** *Mars Facts* retrieved 2020-01-21 from <https://nssdc.gsfc.nasa.gov/planetary/factsheet/marsfact.html>
- Nelson, M. Dempster, W.F. Allen, J.P. (2008)** Integration of lessons from recent research for 'earth to Mars' life support systems, *Advances in Space Research*, 41(5), 675-683 . doi: 10.1016/j.asr.2007.02.075
- Plester, V. (2018)** *On To Mars! Chronicles of Martian Simulations*. Singapore: Springer Nature Singapore Pte Ltd.
- Rapp, D (2016)** *Human Missions to Mars, Enabling Technologies for Exploring the Red Planet, Second Edition*. Switzerland: Springer International Publishing
- Siliezar, J. (2019, 11 September)** Life on the ice. *The Harvard Gazette*. Available at: <https://news.harvard.edu/gazette/story/2019/09/harvard-scientists-at-the-south-pole/>
- Taddeo, T.A. Gilmore, S. Armstron, C.W. (2019)** Spaceflight Medical Systems. In M.R. Barrat. E.S. Baker. S.L.Pool. (eds) *Principles of Clinical Medicine for Spaceflight*. New York: Springer Nature
- Walsh, N.P. (2019, 13 May)** AI SpaceFactory Wins NASA's 3D-Printed Mars Habitat Challenge. *ArchDaily*. Available at: <https://www.archdaily.com/916888/ai-spacefactory-wins-nasas-3d-printed-mars-habitat-challenge/>

