

# BUILT-INTERIOR

An exploration of housing qualities of a Living Box

Kerstin Stahre & Beatrice Wallén

Examiner: Kaj Granath  
Supervisor: Jan Larsson

Chalmers University of Technology  
Architecture and Civil Engineering

Master's Thesis 2023  
Housing Direction  
MPARC

Kerstin Stahre & Beatrice Wallén

Examiner: Kaj Granath  
Supervisor: Jan Larsson

Chalmers University of Technology  
Department of Architecture and Civil Engineering

Master's Thesis 2023  
Housing Direction  
MPARC



**CHALMERS**  
UNIVERSITY OF TECHNOLOGY

## A special thank you

Thank you to our supervisor, Jan Larsson, for your inspiration, support, ideas, expertise and most of all, unfailing optimistic and positive spirit throughout the process.

Thank you to our examiner, Kaj Granath, for your attentive guidance, constructive advice, direction and inputs throughout the development.

## About us



### **Kerstin Stahre**

Bachelor in Architecture at Chalmers  
2018-2021

MPARC Architecture and Urban Design Master  
2021-2023

Master studios:  
Residential Healthcare  
Housing Inventions  
Healthcare Architecture



### **Beatrice Wallén**

Bachelor in Architecture at Chalmers  
2018-2021

MPARC Architecture and Urban Design Master  
2021-2023

Master studios:  
Residential Healthcare  
Transformation and Environmental Care  
Healthcare Architecture

### **Why an approach towards built-in interior?**

We are both interested in housing design, floor plans, flows, materials, and what makes a home pleasant and comfortable. Especially when it comes to interior design and designing small spaces with flexible solutions. Both of us usually have more of an inside-out approach when designing projects, and always put much of our focus on the interior space.

The distribution of labour of this thesis was a collaborative teamwork throughout the whole process. Both of us were equally involved in the research, writing and design work.

# Table of contents

<b>Introduction</b>	1
Background	1
Purpose and aim	2
Research question	2
Delimitations	3
Disposition	3
<b>Method and process</b>	5
Pre-study and research	5
Explorative design process	5
Final design proposal	5
A housing quality manual	6
<b>Theoretical framework</b>	7
<b>Sustainable development goals</b>	8
<b>Unsustainable and sustainable transformations</b>	8
<b>History of the Swedish housing development</b>	9
The million homes programme	10
Housing from the 2000s - today	10
<b>Small apartment trend</b>	11
Evolution to smaller living space	11
The health risks of small apartments	11
Design solutions in small apartments	12
<b>Housing qualities</b>	13
Housing qualities according to CBA, The Centre for Housing Architecture at Chalmers University of Technology	13
Housing qualities according to Umeå School of Architecture	14
<b>Adaptability and flexibility</b>	15
Adaptability	15
History of flexibility in housing	15
Flexibility as a tool for future proofing	15
<b>Material characteristics and properties</b>	16
Wood	16
Cross-Laminated Timber (CLT)	16
Plywood	16
Alternatives to wood	17
Acrylic plastic	17
Linseed oil	17
<b>Reference projects</b>	19
Past and recent innovative design solutions in Sweden	19

Järnbrott Experimental House	19
Kallebäck Experimental Housing	19
Optibo	20
Dream Home	20
<b>Recent innovative design solutions</b>	21
The green box	21
The schoolhouse	22
Snabba hus	23
Shoji apartment	24
<b>Analysis of theoretical framework</b>	25
<b>Design strategy</b>	27
<b>Concept</b>	27
<b>Explorative design process</b>	29
Introduction to explorative design	30
Gropegårdsgatan	31
Topasgatan	33
Äppelträdgården	35
Smedjan	37
<b>Analysis of the explorative design process</b>	40
<b>Design proposal - The Living Box</b>	41
Introduction to design proposal	42
<b>Interior module</b>	43
<b>The Living Box I</b>	45
Finishing materials	47
<b>The Living Box II</b>	49
Finishing materials	51
<b>The apartments</b>	53
<b>The two-room apartment</b>	55
Housing qualities analysis	57
<b>The one-room apartment</b>	61
Housing qualities analysis	63
<b>Analysis of design proposals</b>	68
<b>Discussion</b>	69
<b>Conclusion</b>	71
Suggestion for further research	71
Reflections	72
<b>Reference list</b>	73
<b>Figure list</b>	76

# Abstract

The main purpose of the master thesis is showing how integrated interior elements and objects can be designed to create good housing qualities in small living spaces, without interfering with architectural qualities or accessibility. Integrated interior elements and objects being built-in interior or furniture such as wardrobes, shelves, cabinets, foldable beds, work desk and similar.

The three thesis questions investigate how unconventional design solutions can contribute to spatial configuration, adaptability and sustainability in small apartments. Consequently, the design proposals can generate the ability for apartment layouts and interiors to withstand over time and decrease the need for unnecessary transformations, hence supporting sustainability.

The methodological approach consists of a mix of methods based in a theoretical framework and explorative design, which is continuously evaluated by a housing quality assessment tool.

Historical aspects and contemporary research about architectural qualities, interior design and small-scale living creates the theoretical background. This combined with a thorough investigation and evaluation of innovative reference projects, results in a scope of different theoretical design solutions and developed floor plans.

To emphasise and underline a wide applicability and possible implementation of the design proposals, solutions for interior transformations of both apartments from the million homes programme and the past decade were tested.

Subsequently, the final design proposal of an interior module, a "Living Box", implemented in different apartment types is presented. To verify the quality of the design proposals, a new tool for evaluating housing qualities in apartments, gives an indication of the design proposal's fulfilment and attainment towards housing qualities.

The final design proposal of the interior module, "the Living Box", is mainly made of wood. It is equipped with the essential functions such as kitchen, bathroom, and storage, that easily can be adapted to users' need and preferences by exchangeable finishing layer and integrated objects. This interior module works as a spatial configuration unit that facilitates flexibility, adaptability, aesthetics, and sustainability - contributing to good housing qualities.

**Keywords:** Built-in interior, interior module, spatial configuration, housing qualities, adaptability

# Definitions

To facilitate and diminish misunderstandings while reading the report and avoid repetitive detailed explanations in the text, some specific terms and definitions are explained in detail in this paragraph.

**Built-in interior or furniture** Integrated furnishing such as wardrobes, shelves, cabinets, foldable beds, workspace, and similar.

**Integrated interior elements** Furnishing elements such as cabinets or shelves, or fixed, movable, or demountable walls that divides a space into rooms or zones.

**Integrated interior objects** Integrated, fixed or exchangeable objects, for example furniture, such a foldable bed or a workspace.

**Interior module** Structure containing fixed or exchangeable elements and objects, creating a configuration of various functions in an apartment.

**Living Box** Name of the design proposal, being an interior module containing as a minimum basic functions in a living space such as bathroom, kitchen, and storage.

**MAB** Manual för Analys av Bostadskvaliteter / Manual for Analysing Housing Qualities.

**Small apartment** An accessible, self-contained apartment of maximum 55 m<sup>2</sup>.

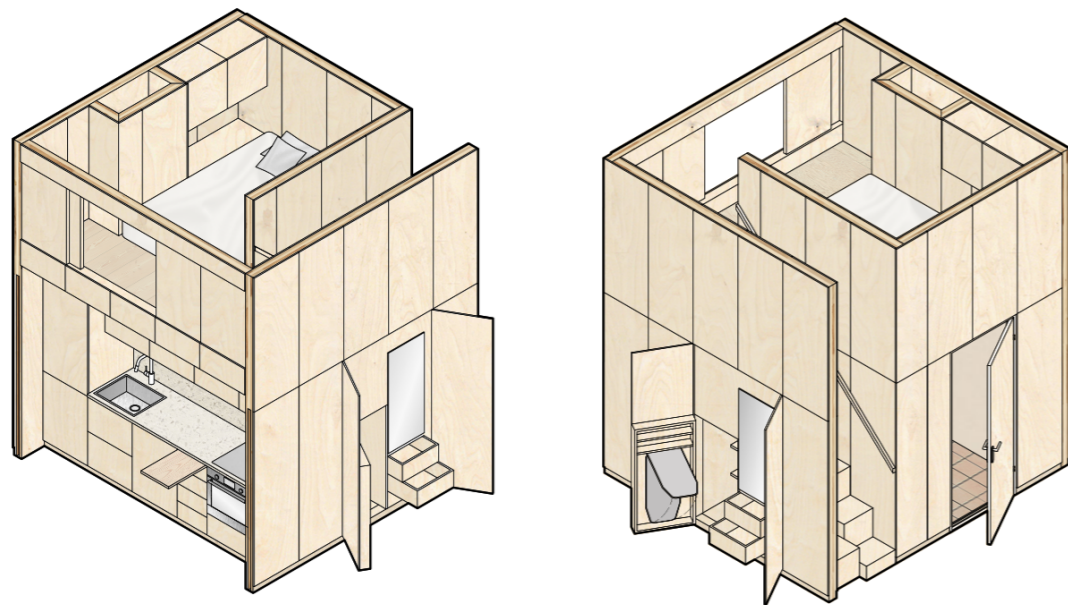

# Introduction

## Background

Official statistics show a trend heading towards smaller apartments and more single households, i.e. less square meters per living space (SCB, n.d.). This brings out the importance of increasing the utilisation of every square meter in living spaces and making maximal use of the available space that allows physical social interactions. To obtain more use of the space without interfering with housing qualities, one approach is to design and implement adaptive, multi-functional and flexible living space with high quality properties and a pleasing atmosphere.

At the same time, a recent study reveals that many apartments are transformed and remodelled to accommodate resident's particular needs. Some of these changes are done due to personal preferences, while the same study shows that many of the transformations are done due to unused floorspace, bad quality and poor original design (Femenias et al, 2016). This development is highly unsustainable, and could be counteracted by designing adequate living space with high quality that lasts over time. According to Barbosa et al (2015), to meet the need to reduce the environmental footprint, one solution could be smart interior design for small apartments in cities.

Inspirational, unconventional, and often custom-made examples of smart interior design for small apartments are easy to find in various sources such as magazines, books and websites. They showcase creative, and often quite luxurious solutions and transformations of small spaces. Contrarily, it is more difficult to find this type of innovative solutions implemented on a larger scale, showing a lack of feasible alternatives for the public. Besides, the lack of quantified evaluations of floor plan layouts before and after renovations and transformations, encouraged using a structured method both as guidance during design work and as a final receipt of accomplishment of the design proposals.

The main approach is showing feasible alternatives and more unconventional floor plan solutions created by interior elements and objects, questioning the need of conventional elements such as walls to improve the use and achieve valued qualities in the living space. The definition of integrated interior elements and objects in this thesis are built-in interior or furniture, such as wardrobes, shelves, cabinets, foldable beds, work desks and similar.

## Purpose and aim

The purpose of the master thesis is to discuss how adaptive and unconventional interiors with high quality can create more useful living spaces, while reducing the need for transformations and unnecessary climate impact. The findings can be used as a complement to conventional design solutions that can be used by the architectural profession. Inspired by innovative and not necessarily mass-produced solutions and ideas, this thesis shows new alternatives to more conventional layout that can be implemented on existing housing stock or completely new housing projects. A thesis strongly connected to today's needs and contemporary research, will contribute and add value to stakeholders within the architectural practice, building clients and discourse, and in the long term, the end user.

### What?

The aim is to show how integrated interior elements and objects can create good housing qualities implemented in existing apartments and in new apartments.

### Why?

To meet the current and future social, economic, and climate challenges, it is important to explore and suggest unconventional and innovative solutions that support sustainability without interfering with quality and well-being in housing.

## Research questions

In the search for spatial qualities in apartments, the research questions focuses on three different main perspectives:  
Spatial configuration, adaptability and sustainability.

How can interior elements work as room divider and spatial configuration?

How can integrated interior elements and objects be adaptable with a variation of functions?

How can integrated interior elements and objects be designed to last over time and support sustainability?

## Delimitations

The master thesis is done at Chalmers University of Technology in the spring term of 2023. The research is limited to one term, i.e. 30 credits / 20 weeks full time studies.

To strengthen the relevance of the master thesis, it is set in a contemporary Swedish context, considering the Swedish building laws and regulations. The final design proposal includes designs that challenge view and interpretation of the current building norms, such as higher ceiling heights and first ideas for structural solutions.

The focus of the thesis is interior modules implemented in small apartments up to maximum of 55 m<sup>2</sup>, for young people, couples, and small family constellations as the main target group. The designs are aimed for people in need of a small, flexible and adaptable living space. As the apartment building typology naturally is situated in an urban context, the master thesis is focusing on that perspective.

During the first explorative design phase, design proposals are implemented on a limited number of pre-selected, apartment floor plans both built during the million homes program in the 1960-1970 and since 2010 in Sweden. Additionally, final design proposals containing new interior modules implemented in new apartments are presented. The focus is on the interior design of apartments. The exterior shell, such as facades and building construction elements, are not included. Cost or cost comparison for the design proposals are not considered.

## Disposition

After the introduction of the method and process, the thesis continues with an exposition of relevant research and literature, including a brief history of the housing development in Sweden, focusing on the periods connected to the chosen methods and references. Hence learning about important housing qualities are introduced, followed by a summary of important innovative and groundbreaking reference projects showcasing different housing qualities.

Thereafter the results from the design are presented. Finally the results are methodically analysed, and discussion and conclusions are presented based on both theories, method results, own observations, experiences, and reflections.

# Method & Process

A combination of various methods and processes were used to create a substantial knowledge and background for the design proposals and basis for analysis and conclusions. The following steps and main chosen methods and tools that were applied and iterated during the process, are described in this section.

## Pre-study and research

In the first phase, a selection of substantial literature and research material within pertinent themes, such as sustainability, historical background, typical dwelling characteristics, and qualities, followed by today's trends, needs and challenges, gave a relevant and thorough background and knowledge. A selection of reference projects and examples were used as an inspirational source for a concept and design work.

Thereupon, a framework for the first part of the design process, the exploratory phase, was settled. A limited number of small apartment floor plans from the million homes programme and apartments built since 2010 in Sweden, were randomly pre-selected to serve as a framework for the first design phase and showcase possible implementations in transformation projects

## Explorative design process

The first design phase was an exploratory stage, where various solutions of different interior modules, inspired by references and theory, were designed to fit into the framework floor plans. This exercise facilitated understanding of limiting measurements, possible configurations, and implementation of interior modules in existing floor plans. However this proceeding was entirely a learning phase and not aiming for a final design proposal.

Conventional design methods such as sketching both digitally and by hand, were used throughout the process. The explorative design phase was continuously supported by referring to a housing quality evaluation tool (MAB) that was used as a toolbox and inspiration to create good qualities with integrated interior elements and objects for the subsequent design proposals and to optimise the result.

Finally, a systematic evaluation of the housing qualities of the original framework floor by using the MAB manual, was followed by a comparative analysis of the new design proposals implemented in the framework layouts. The housing quality tool, MAB, is further explained at the end of this section.

## Final design proposal

The second design phase consisted of designing and documenting theoretical proposals of interior modules with integrated interior elements and objects. This final design proposal, the interior modules themselves, include a scope of a variety of different solutions that can be combined in different set-ups, materials and finishes.

The interior modules were implemented on new apartment floor plans that make better use of the space by having good architectural qualities already defined in the previous stages. The qualities of these design proposals were also evaluated according to the tool MAB, to assess the performance of the floor plans in combination with the interior module. In addition, the decisions in the design process were supported by including and assessing sustainability (material, adaptability, durability, e.g.) and aesthetics (material, details, atmosphere, e.g.), focusing on material of the final interior modules.

Above chronological order of the four stages was not firm, and iterations between the stages were necessary during the process.

# A housing quality manual

In the process, relevant and applicable parts of the MAB tool for evaluating housing qualities were used. MAB is a design manual developed by researchers at CBA, Centrum för Boendets Arkitektur (The Centre for Housing Architecture) at Chalmers University of Technology. MAB consists of 28 dwelling qualities that are analysed and registered in an excel file. Some of the qualities have sub-categories that require further analysis. There is a manual for each quality with a short description of what should be graded and how. MAB has three main categories - The dwelling, the building and the residential courtyard. In this thesis, only one of the three categories, the dwelling, was used in order to analyse and grade both original floor plans and the latter design proposal.

The dwelling-category has three sub-categories including functionality, spaciousness and atmosphere. Each sub-category includes four separate qualities:

- **Functionality:** Space efficiency, technical rationality, furnishable space and potential to remain a resident (in case of an accident or sickness).
- **Spaciousness:** Axiality, circulation, room shape and flexibility.
- **Atmosphere:** Several facade directions, daylight, balcony and dark space.

The quality categories are summed up in the MAB tool and summarised with the grade gold, silver or bronze. For the housing part, the following grading applies in every sub-category:

Gold: 3+ qualities fulfilled  
Silver: 2 qualities fulfilled  
Bronze: 1 quality fulfilled

# Theoretical framework

This section summarises the background that created a basis for the development of the design proposals. The starting point is sustainability, a subject that is embedded and applied to certain topics on a more detailed level throughout the text. It continues with how floor plans, qualities, and characteristics of the housing stock have changed over time in Sweden. After a brief trip through housing history, the focus shifts to the fact that apartments are smaller today than in the past and the main reasons for this development. Furthermore, some of the both negative and positive effects of living smaller are introduced. To get a broader perspective and better understanding of the need for overall good housing qualities, the attention turns to desirable qualities in housing. A short introduction to typical flexible solutions in the past and present, are presented. Furthermore, examples of innovative solutions for small apartments are highlighted to give both knowledge about the past and inspiration for the future. Finally, the main materials for the final design proposal are presented from a sustainable and aesthetic point of view.

## Sustainable development goals

As commonly known, the three key areas of sustainability are based on economic, social, and environmental development (United Nations, n.d.-e). Further, the basics of the 17 Sustainable Development Goals (SDG) developed by the United Nations (n.d.-f) to transform our world for the better and protect the environment, are also commonly known. Some of the goals are more relevant to the thesis design proposals, whereas four goals are highlighted below, even if more goals are relevant and connected to the design proposals to a certain extent.

Primarily, the goal #12, Responsible consumption and production, is relevant as it stresses the importance of reducing the global material footprint and minimising waste by recycling, reducing the consumption, avoiding products from industries with large pollution emissions (United Nations, n.d.-c).

The goal #13, Climate action, points out the importance of reducing carbon dioxide (CO<sub>2</sub>) emissions to prevent the acceleration of global warming (United Nations, n.d.-a).

By choosing wood as a main material in the construction and finishing layer of the interior module, the goal #15, Life on land, is highly relevant, as it emphasises and cares for the forest and consumption that is sustainable sourced and respects wildlife, biodiversity, and eco-systems (United Nations, n.d.-b).

For the long term, the goal #11, Sustainable cities and communities, (United Nations, n.d.-d) is important to the matter at hand, as it claims if you build and design better conditions in the community, it will consequently have a large effect on quality of life for the inhabitants.

## Unsustainable and sustainable transformations

More and less necessary transformations and refurbishments of existing housing stock are done for various reasons. In a study led by Femenias (2016) it was discovered that poorly planned floor plans and low quality of materials and details were some of the main reasons why residents chose to do renovations or rebuild their apartments in Sweden. Lack of storage or furnishability, poor design of the kitchen or bathroom and a wish for a more open floor plan are the most common reasons for the transformations. The study proves that there is a need for more storage and a more open and well-planned space in the contemporary home. Building with better quality of materials and details could help with decreasing the turnover of new residents in small apartments (Femenias et al, 2016).

Höjer and Mjörnell (2018) presents four measures in a chronological order of how to decrease the greenhouse emissions such as CO<sub>2</sub> of the built environment, where building new buildings comes last in list. In this list, reducing the demand of space comes first, followed by intensifying the use of the space and thirdly, transforming and refurbishing existing buildings to meet current demands before lastly, building new.



Figure 1. Sustainable Development Goals, United Nations  
Copyright: United Nations

## History of the Swedish housing development

As transformations evidently are important and also preferred instead of building new from a sustainable point of view, the specific properties of the housing stock originated from the largest tendencies, shifts, trends, societal and political influences, a summary of housing history is presented. Two eras are presented more deeply, the million homes programme due to the large number of apartments in need of refurbishment and the last two decades for its different properties and future need of renovations.

Professor Nylander describes how Sweden since the 1900's, have had quite a unique social housing policy that included measures to reduce housing shortage and obtain certain quality requirements (2018, pp. 5-12). Cooperative building organisations were developed in the early 1900's to counteract overcrowding and poor housing. A few decades later, the government implemented subsidies to build simple but modern dwellings to support poor families with many children. The idea that all habitants should live in good quality housing, was realised mainly by governmental subsidies, rules regarding quality and standards and communal housing corporations without profit requirement. Around 1950, Sweden became the leading country in Europe in building modern and high quality that culminated with the fast built million homes programme, in which one million homes were built in a decade starting in the mid-60's.

The social housing policy changed with the withdrawal of subsidiaries in the 1990's, followed by the communal housing corporation to act profitably and according to private market conditions. With a fast-increasing population, increased share of single households combined with geographical movement to urban areas, overcrowding and housing shortage became a problem during the 2000's which was followed by increased building cost, housing shortage in combination with free market prices.

Nylander shares how the extensive political involvement in housing was supported by norms and laws based on research, tendencies, and requirements to secure a basis of housing stock's qualities and characteristics (2018, pp.5-12). A few of them are important to get a broader perspective on qualities and features in current housing stock from different eras. A fundamental rule is the introduction of accessibility for impaired or disabled people. It started in the end of 1960's with recommendations that were further developed with specific measurements and included in Swedish building statutes and has been continuously complemented and updated.



Figure 2. Tensta Allé, Stockholm

## The million homes programme

The million homes programme in Sweden was built from 1965 until 1974 with the aim to build one million homes during a decade, replacing low standard and unmodern apartments, and reducing overcrowding (Nylander, 2018, pp. 171-220). Finally, the million homes programme resulted in around 850 000 apartments (Nylander et al, 2018, p.12). In comparison, the current amount of apartments in Sweden is roughly 2 600 000 (SCB, 2022).

At this time, the living standards increased continuously, which consequently raised higher demands of the housing standards (Nylander, 2018, p.176). Stenberg (n.d.) claims that the dwellings from this time are very well-built and robust, which makes them flexible and adaptable. The apartments were generally well-planned, well-furnished, with high qualities and ample access to natural light (Hall and Vidén, 2015). Although, the million homes programme was criticised for only focusing on standardisation and how people should live, and not considering the final users' needs and desires in a home (Hall and Vidén, 2015). Floorplans and rooms were organised according to function and based upon standardised measurements of furniture to fit the typical nuclear family constellations at the time (Stenberg, n.d.). Now, several decades later, these apartments and floorplans do not fully meet today's individualism and new way of living and preferences (Stenberg, n.d.).

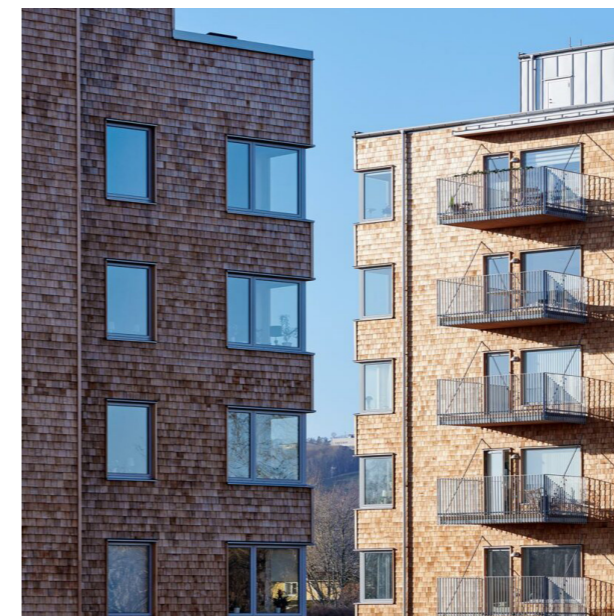

Figure 3. Building in wood from 2018, Frostaliden, Skövde.

## Housing from the 2000s - today

The last two decades were dominated by large demographic changes, such as a fast growing population mainly caused by immigration in combination with relocation to the larger cities. The number of households increased dramatically, caused both by the larger population and an increased share of single households and households with single parents with children (Nylander, 2018). As the housing demand and production mainly concentrated on the expensive and limited available land in urban areas, and the production cost for building housing was increasing, and the new housing became too costly for the buyers and tenants. A measure to lower the building cost, was to build less square metres per apartment. In 2003 a new, typical 2 room apartment was in the range of 60-65 m<sup>2</sup>. Ten years later, the same apartment configuration was around 40-45 m<sup>2</sup>. New regulations in 2014, apartments smaller than 35 m<sup>2</sup> had less requirements which made it possible to fit all required functions in around 22 m<sup>2</sup> (Nylander, 2018).

Ecological and social sustainability became important quality requirements from both clients and authorities during this period (Nylander, 2018). The newly developed districts were built with the aim to create variation in the cityscape with a mix of housing and different functions in the developed areas. During this time, the development of using wood to a larger extent in the construction and in interior surface layers, became more common. New types of common living housing emerged, consisting of individual typical apartment configurations fitted in less square metres (Nylander, 2018). The smaller individual space was compensated with larger shared space dedicated for leisure activities and social encounters. The floor area was effectively designed with small communication space, and the floor plan configuration was flexible. Large window openings and balconies gave good opportunities for access to daylight and sightlines to the outside. Prefabricated micro apartments with varied results in both construction cost and quality were built (Nylander, 2018).

## Small apartment trend

The emergence of smaller apartments has had certain consequences on the design, functional and spatial configuration, housing quality and finally the user's health and wellbeing. However, in Sweden, the building laws for accessibility, general advice and rules according to Boverket (2020) for measurements and furnishing must be respected.

### Evolution to smaller living space

As previously mentioned, statistics show that newly built apartments in Sweden have become increasingly smaller in size, especially over the last two decades (SCB, n.d.). The average size one-room apartment built in 2020 is 32,8 m<sup>2</sup>, and the two-room apartment measures in average 51,9 m<sup>2</sup>. In comparison to apartments built in the year 2000, the one-room apartment is 20 % smaller in size and the two-room apartment is 13 % smaller (SCB, n.d.).

There has been an increased interest in smaller apartments during the last two decades due to two main reasons: the first being economic factors, such as the very high housing prices and economic inflation, and the second being social and demographic factors (Gronostajska, B., Szczegielniak, A., 2021). Some of the social and demographic factors include changes in the modern family model, with people living in single households of an extensive period of their life. At the same time, there is a growing elderly population that often live alone in homes that are too large for them. There have also been changes in how the residential spaces are being used and in the furnishings of apartments. For instance, combining functions in the home such as kitchen, dining room and living room into one large social area has been a standard for many years, both in larger and smaller apartments (Gronostajska, B., Szczegielniak, A., 2021). Furthermore, Gronostajska (2021) explains that some residents choose their dwelling based on lifestyle and outlook on life. Greater environmental awareness leads to more eco-friendly and minimalistic lifestyles. Smaller apartments need less energy and resources to build, maintain, cool and heat.

### The health risks of small apartments

However, due to their small floor areas, smaller apartments can create negative consequences and impact the quality of life if not designed properly. The first being the risk of physiological consequences, because of the physical strain of needing to fold or move furniture and retractable walls (Urist, 2013). Since some small apartments are too small to hold basic furniture like a bed, table, and sofa at the same time, residents must reconfigure their home throughout the day, by maybe folding down a bed, or hanging up a dining table on the wall. What might seem easy at the beginning ends up including a lot of small inconveniences. In this case, residents might eventually stop using their foldable furniture every day and the space will start feeling even more constrained.

The second being the risk of psychological consequences such as the feeling of overcrowding (Urist, 2013). In terms of small scale living, there is a tendency to focus on functional things, but an apartment has to fill other psychological needs as well, such as self-expression and relaxation, that might not be as easy in a cramped space. People living in small apartments tend therefore to spend a lot of time outside of their home and perceive the city as an extension of their home (Gronostajska, B., Szczegielniak, A., 2021). Due to the small space, many of the home activities such as cooking and social gatherings with family and friends take place outside of the home.

## Design solutions in small apartments

In a study done by Gronostajska and Szczegielniak (2021) different design solutions in small apartments evaluated to find the most common and effective design solutions. The research studies 30 apartments under 40 m<sup>2</sup> in different European cities. The solutions are categorised into four different categories; functional, spatial, optical, and furniture solutions.

**The functional solutions** include; deciding not to section off certain functions or rooms, designing with the minimum floor area, and with minimum circulation space, and designing space that functions differently at different times or combining functions.

The functional design solutions are mainly used in new built projects and in the early stage of the design process. It can be hard to apply to existing dwellings.

**The spatial solutions** include; using a room's full height, using furniture that extends along with the entire height of a wall, stacking functions, using a mezzanine, using other means to divide space than walls, using space under the stairs or furniture and using a simple plan geometry with simple floor plans. Some of the spatial solutions require certain measurements and can therefore be used in new projects more easily, but can however also be used in existing apartment buildings.

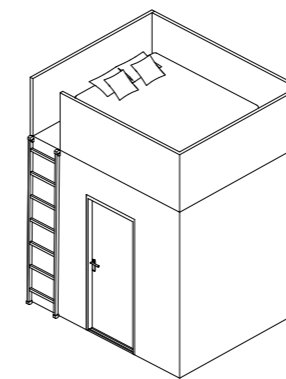

**Figure 4.**  
Example of spatial solution, stacking functions on a mezzanine.

**The furniture solutions** can both be used in new and existing apartment buildings. Furniture solutions include; designing retractable or hideable furniture, using built-in furniture, using sliding doors or windows, designing movable walls.

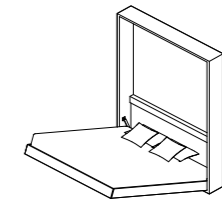

**Figure 5.**  
Example of furniture solution with a foldable bed.

**The optical solutions** are the easiest and most affordable solutions that can be used in both new and existing dwellings. The optical solutions include; using light colours, designing simple or hidden details and joints, using smooth surfaces, a lack of patterns, maximising the daylight, using of mirrors, using openings in walls between spaces.

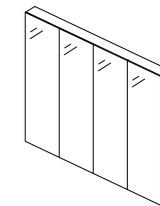

**Figure 6.**  
Example of optical solutions, for example mirror wall.

The same study (2021) showed that the most commonly used design solutions were the functional and spatial solutions. Even though decisions on functional solutions must typically be made in an early stage, they were used most frequently. For instance, skipping certain functions or combining functions, consequently saving significant floor space. Among spatial solutions, one of the most popular procedures was function stacking by placing a bed on a mezzanine. This suggests that in the case of designing well-designed small apartments, design solutions should be incorporated in the early planning stage of the apartments. In the case of optical solutions, it was observed that the most commonly used solutions were the application of light colours, hidden or simple details or joints, and efforts to maximise daylight inside the unit. The furniture solutions were least commonly used, except for the built-in furniture, which was used in all of the apartments in the study, suggesting that built-in interior after all is an crucial feature of small apartments.

## Housing qualities

To get a wider view and understanding of which housing qualities that are important to consider when designing, a summary of two academic studies are presented in the following part.

### Housing qualities according to CBA, The Centre for Housing Architecture at Chalmers University of Technology

CBA performs research connected to housing and has presented a list of criteria linked with properties and qualities of housing that both are based on previous research and more recent research by CBA (Nylander, O. et al., 2018). CBA's researchers point-out that the research is evidence based and the tenants' opinions are in focus and brought out in their studies regarding housing qualities. A common list of criterias makes it possible and easier to discuss, create understanding and basis between different professionals and stakeholders for important architectural qualities (Nylander, O. et al., 2018).

Below are the six criteria connected to housing quality by CBA presented with a short description.

1. Function / structure, measurements, efficiency: Assess the functions and the possibility to furnish the space with standardised measurements and the space efficiency.
2. Room experience: Evaluates qualities such as axially, sightlines, enfilade, and spatial relationship between rooms.
3. Wellbeing and health: Estimate the access to daylight by size and shape of window openings, direction of the room and views to the outside. Consider the use of sustainable materials, high level of detailing.

4. Flexibility and room organisation: Checks the possibility for changes, variation of use and presence of zoning between private and public within the home.
5. Outdoor yard and building type: The housing should create good social space and fulfil requirements connected with different aspects of sustainability such as use of sustainable materials, energy systems and LCC, Life Cycle Costing.
6. Communication, apartment type: Focus on the possibility to create a housing that feels safe, offers distinct zones for private and public and interconnecting space between outdoor and indoor.

Above qualities are all represented in the MAB tool Manual för Analys av Bostadskvaliteter (Manual for Analysis of Housing Qualities) developed by CBA, already presented in the section Methods and process.

## Housing qualities according to Umeå School of Architecture

A study of architectural attributes and qualities of housing by Ulf Nordwall (2012) serves as a complement to CBA's (Nylander, O. et al., 2018) profound and detailed research of the same theme. Nordwall (2012) carried out several studies with different methods finding ways to quantify and measure the importance of different architectural attributes and qualities. The methods and results from Nordwall's studies were mainly addressed to be used for property and facility management, but the chosen attributes, qualities, and terms, are to some extent applicable in the search of important qualities of housing. Six architectural non-measurable attributes that give important understanding and knowledge for building developers, were identified by Nordwall (2012) in one study.

The six attributes durability, change, renewal, materials, execution, and planning are briefly explained below.

1. Durability: How technical aspects are enduring over time, but also how the materials and building itself are ageing. Advertise the importance of awareness of architecture and expression possibility to last over time as people's attitude towards architectural styles changes continually.
2. Change: Focus on if a building has the potential to change, meaning if it has a flexible and universal design that admits changes.
3. Renewal: The possibility to renew and replace worn-out material gradually if needed.
4. Materials: Highlight the importance of material choice. Exemplify industrial processes and new materials that imitate traditional materials of high quality, where the result does not always meet expectations.
5. Execution: The term is about details, how they were handled during execution and how the different details can be maintained during the lifetime of a building.
6. Planning: The organisation and relationship of the rooms in a building.

Nordwall (2012) concluded that above attributes are directly connected to the level of the tenants' appreciation of their homes. Nordwall (2012) performed a second study that focused on how tenants valued some chosen architectural qualities by giving some qualities a monetary value.

The following qualities were used in interviews with tenants:

- Flexibility: Flexible room admits versatile use of the space. Points out the importance of the shape of the room in combination with connective openings such as doors.
- Patina and mellowness of the building components: The materials characteristics and degradation process are impacted by ageing. Materials with a clear patina are perceived as authentic and more appealing. Different materials age in different ways, and if the ageing is accepted or not, varies from material to material.
- Properties and characteristics of the surroundings.

This study (Nordwall, 2012) shows that tenants appreciate housing with natural materials that improve by age, an open plan layout and abundance of daylight. The design of details and building components such as windows, doors, and cupboard interiors, are important.

## Adaptability and flexibility

Recurring desired housing qualities are adaptability and flexibility. The denomination of adaptability and different ways of obtaining adaptability in apartments are described and explained. Further, to get a better understanding of how flexibility has been used throughout history and its importance, a summary on the subject is presented in this section.

### Adaptability

Braide (2019) uses the term adaptability in the meaning if an apartment has the ability to expand or decrease depending on changes in number of residents. Same author defines the three concepts to obtain adaptability in apartments by generality, flexibility, and elasticity. Generality refers to when rooms are compatible and admit diverse use without needing to change the space physically. Flexibility is defined as a measure to modify the apartment layout by using movable walls and furniture that can create more rooms and change the size of the rooms without changing the apartment size. Elasticity is possible to attain when the size of the apartment can either be expanded or reduced by possible connectivity to neighbouring space.

### History of flexibility in housing

Living in small and flexible spaces is thus not a new phenomenon. Flexible and built-in housing solutions have been developed in mainly two ways through history. The first way is the development through vernacular architecture and culture, while the second is the result of architects developing alternative design solutions to optimise the efficiency of the space (Till & Schneider, 2007). One of the earliest examples of flexibility in Sweden is the vernacular one-room cottage, dating back to the Mediaeval times. The rooms of vernacular houses were spacious enough to function as either a kitchen, living room or bedroom, often depending on the time of the day (Nylander, 2018). Similar room sizes were used in the workers' homes constructed in many Swedish cities towards the end of the 1800's. This type of general-purpose room is also found in dwellings dating from the early 1900's.

After the First World War, Europe faced a large demand for urban housing, particularly for the working class (Till & Schneider, 2007). Previous models of urban housing did not meet the new needs in terms of economics or density. As a result, space standards were drastically reduced in order to provide a large number of dwellings at minimal cost.

One response was to introduce the notion of flexibility, meaning that the space needed to be used as efficiently and flexible as possible. Architects started developing new types of housing floor plans, many of which had elements of flexibility and built-in interiors.

One method of achieving flexibility was that the use of the rooms were not specifically determined. Rather than defining certain uses to specific rooms, these floor plans allowed the user to decide how to use and occupy their home. Another method of achieving flexibility within the home was rather determined by the architect, with architectural elements and furniture folding and unfolding depending on differing needs within the same space. Different functions overlapped and had different uses during the day, thus offering more floor space, despite limitations in actual apartment size.

### Flexibility as a tool for future proofing

During the past two decades there has been a decrease in the number of traditional family homes (Till & Schneider, 2007). At the same time, there is an ageing population, an increase of the number of single-person households, an increased demand for shared accommodation, and a shift towards working and studying from home. Statistics show that these trends will probably continue into the next few decades, but with yet uncertain demographic developments. What housing needs at the end of the 2000s will be different from today's needs and wishes. Therefore housing architecture needs to adapt to these changing demographics. Changing demographics require new architectural solutions that incorporate flexibility into new types of housing.

## Material characteristics and properties

For the interior modules, material characteristics, and properties are of high importance from both a sustainable and aesthetic perspective. By a careful material choice for the ingoing components, the interior modules can contribute to a sustainable environment from different perspectives. To secure use of materials that supports previously mentioned global sustainable goals, the most important materials for the ingoing components of the interior models and the surface finish are presented in this section.

### Wood

The main material for both the construction and finishing layer for the interior module is wood in various forms for its valuable and beneficial properties and contribution to sustainability. For an prefabricated interior module, the selected wood material for the construction is CLT (Cross Laminated Timber), clad with thin and exchangeable plywood boards.

An increased share of using wood in buildings instead of carbon intensive materials, can decrease the total carbon emissions from the building sector (Hill, 2019). Same author (2019) concludes that the use of wood in the built environment originated from a sustainably managed plantation woodland, works as a climate change mitigation measure. Wood is a natural and renewable material which can be sourced and manufactured locally with short transport distance (Svenskt Trä, 2023). The material absorbs carbon dioxide during its lifetime and when the wood is worn-out, wood can be used as biofuel and replace fossil fuels.

Research indicates that wood used in interiors has a positive psychological impact on human health and wellbeing (Häyrinen et al., 2020). Thanks to wood's ability to buffer moisture and creates a good indoor climate and the material in general lead to positive feelings and experiences for the users (Alapieti et al., 2020).

### Cross Laminated Timber (CLT)

CLT is a mass timber panel product that is manufactured in an energy efficient process by glueing planed timber in several layers, rotated 90 degrees for each layer. The panels are dimensionally stable, strong and can be assembled fast with a high degree of prefabrication (Holmen, 2023). CLT is efficiently used for load bearing structure in many types of buildings. Prefabricated, assembled volume elements and panels elements, are industrially manufactured and have both economic and sustainable advantages (Svenskt Trä, n.d.).

### Plywood

Plywood is made by several wood veneer layers that are glued together. The glue is based on fossil resources. The material can be made of diverse types of wood, panel sizes, thickness, and quality. In Sweden, the core veneer is normally made of fir, spruce or pine tree, and the finishing surface veneer can vary (Svenskt Trä, 2023).

## Alternative to wood

In case of transformation of existing apartments, where complete prefabricated modules are not possible to install at site, an alternative with a traditional wooden stud- and beam construction in combination with recycled boards, with or without plywood boards as finishing layer is a feasible alternative.

Strong and sustainable boards of type PackWall by Recoma made of recycled packing waste with low CO<sub>2</sub> footprint in comparison with conventional solutions (Recoma, 2023). The construction board can be used as a finishing layer as is or in combination with other finishing materials.

## Acrylic plastic

For the parts covered in mirrors, recyclable acrylic plastic can be used instead of glass mirrors. Glass mirrors are not recyclable, are less durable and strong and with heavier weight in comparison with acrylic plastic, which makes the acrylic mirrored plastic a better and safer alternative (Ösönerplast, 2022).

## Linseed oil

A finishing treatment of the wood is needed to protect the finishing surface, prolong its lifetime and at the same time improve the aesthetic properties. Instead of using more conventional water-based paint, linseed oil contains only natural ingredients such as locally produced linseed and pigmentation without any synthetic substances such as plastic (Ottosson Färgmakeri, 2022). Many water-based paints contain plastics and a report by Environmental Action (Paruta et al., 2022) claims that 58% of the microplastic in the ocean originates from paints.

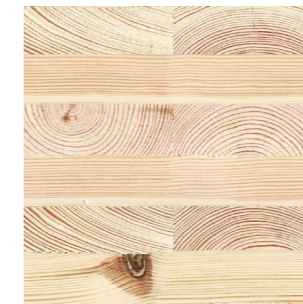

Figure 7. CLT wood



Figure 8. Untreated plywood

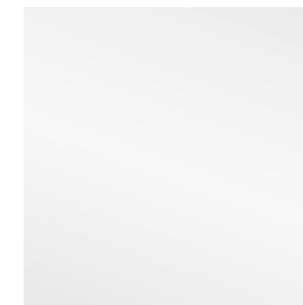

Figure 9. Acrylic plastic mirror



Figure 10. PackWall, made of recycled packing waste



Figure 11. Linseed oil treatment on plywood

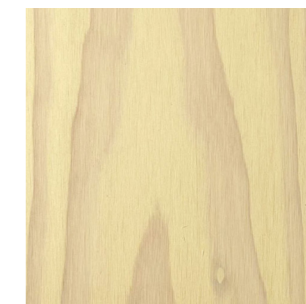

Figure 12. Linseed oil treatment on plywood



Figure 13. Linseed oil treatment on plywood

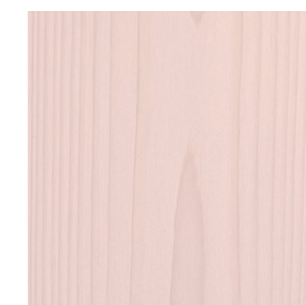

Figure 14. Linseed oil treatment on plywood

## Reference projects

### Past and recent innovative design solutions in Sweden

To understand what kind of innovative projects focusing on flexibility have been done previously in the Swedish context, a few examples of housing projects are briefly summarised. The condensed presentation contains both historical and recent housing projects, details on the flexible elements of the dwellings, and a short reflection on the outcome of the projects.

#### Järnbrott Experimental House, Göteborg Tage and Anders William Olsson (1953)

The first example is an experimental housing project of one five-storey building of 20 apartments, that was the winner of a competition for new types of housing arranged by Göteborg municipal housing company in 1950-1951 (Till & Schneider, 2007). It had two main features: an open floor plan and modular interior. The fixed elements in the floor plan were reduced to a bathroom, a kitchen, and a single column in the middle of an otherwise completely open space. All room divisions were made with a modular system of movable panels and the future occupants could determine the interior layout both before moving in and changing it over time. However, the demountable walls have been replaced today, as the tenants experienced acoustic problems between the rooms and disliked the visible joints in the wall panels.

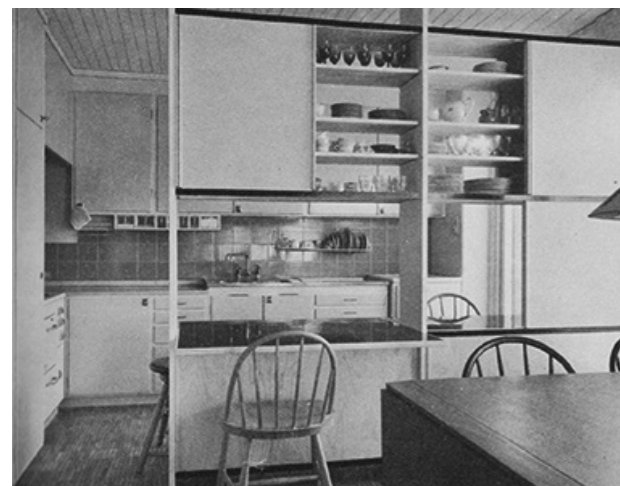

Figure 15. Kitchen in the Experimental House on Modulatorsgatan in Järnbrott, Gothenburg

#### Kallebäck Experimental Housing, Göteborg Erik Friberger (1960)

The second example was built in 1960, when architect Erik Friberger designed family homes by stacking concrete structures on top of each other, to create housing with the character of independent villas in a quite central location (Till & Schneider, 2007). It was an experimental housing idea, focusing on flexibility and prefabricated solutions. The prefabricated, overhung deck in concrete created the boundaries, a plot, for the individual 18 houses in the building. Then it was up to the users to develop their own "villa". The "villa" in this building would have many of the advantages of a single family home within the "floating" plot. Friberger's idea was that the user's home could expand or shrink, be reconfigured, and changed according to their individual and changing needs. The freedom in the plot should generate lush, green gardens and not only dwellings on the deck. But most of the houses were built in the whole plot already from the beginning and didn't become as airy and developable as planned by the architect. The houses were quite a unique housing type, but it has not been replicated.



Figure 16. Kallebäck Experimental Housing in Gothenburg. Stacked "villas" in a concrete structure.

#### Optibo, Göteborg White Arkitekter (2003)

The third example, Optibo, was a research project built as a display apartment in Göteborg in 2003 (Boverket, 2004). The concept of the apartment was a small, but very flexible space, designed for well-educated couples without children, living a social life in a central part of the city. Aiming for an apartment of 25 m<sup>2</sup> with functions that normally fits in a three-room apartment of the size 75 – 80 m<sup>2</sup>, was achieved by technology and built-in smart solutions. Kitchen and bathroom were fixed, while the bathtub, bed, dining table, chairs and machinery for the lifting devices were lowered under the floor. The materials had to be durable, recyclable or reusable, resulting in the materials mostly being wood or glass. Due to many movable parts in the apartment, the question of safety became crucial. To make sure that no accident would occur, there was a strict safety procedure, resulting in it only remaining a display apartment.



Figure 17. Kitchen with retractable chairs and table in Optibo.

#### Dream Home, Linköping White Arkitekter (2017)

Last and quite recent example, Dream Home, was a research project designed to showcase the potential of a flexible universal dwelling concept (Dream Home, 2022). The concept was based on a floor area of only 55 m<sup>2</sup> with moveable walls that easily could be divided into one to five rooms plus a kitchen. This apartment layout could work for different family constellations, changing from week to week. As the apartment was part of a newly built house, the adaptations were simple. Ceiling height and floor depth made room for the customisable parts of the apartment that were designed to be simple to use, enabling easy change of layout for the residents when needed. By removing one of the walls, three small rooms can be created along one side of the apartment (Norrköpings Tidningar, 2017). In this space, a desk and bed can then be folded out from the wall. In the living room, a double bed can be lowered from the ceiling and screened off with curtains.



Figure 18. Interior of the Dream Home in Linköping. Storage under the floor, bed hanging from the roof, and movable walls.

## Recent innovative design solutions

Many other innovative examples of small apartments, which have more unique, customised, and from quite luxurious or more simple layouts solutions, are found in different media. The examples are not necessarily driven by academic research, and appear to have emerged by individual need, preferences, ideas and interests. The chosen reference projects serve as a reference and inspiration for the design proposals of the thesis. The references include projects both from Sweden, Europe and the USA, showing a wide range of interesting approaches to design for small spaces.

### The green box, Berlin Ester Bruzкус Architects (2020)

The green box is a transformation project by Ester Bruzкус Architects in 2020 (Christie, 2021). By placing "a green box" as a dividing element in the centre of the long apartment, circulation can flow around, creating rooms on all four sides. The box contains the kitchen on one side, and two bathrooms on the other side. This creates a more private enfilade of rooms for bathing and dressing on one side and large social space on the opposite side. The palette of rich colours contrasts with neutral raw concrete walls and ceilings.

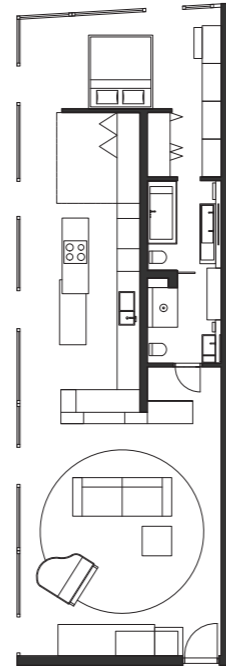

Figure 19. Floor plan 1:200



Figure 20. The functional green box by Ester Bruzкус Architekten, viewed from the living room towards the kitchen.



Figure 21. The hallway including the entrance door in mirrors, in the green box by Ester Bruzкус Architekten.

### The schoolhouse, New Orleans Rome Office (2019)

The Schoolhouse is a transformation project by Rome Office in 2019 (Luco, 2020). The historic school building from 1894 was transformed into multi-family housing by placing a "Box-for-Living" in the centre of each old classroom. These boxes contain the essential components for everyday living: a kitchen, bathroom, wardrobes, entertainment, laundry, technical storage, and a loft. By centering the box in the old classrooms, the building's character and historic detailing are left undisturbed and exposed, while creating rooms for an one-bedroom apartment in a smart way.

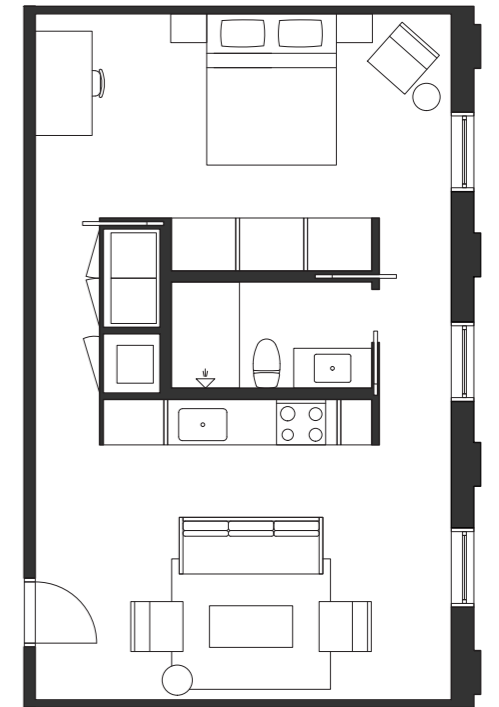

Figure 22. Floor plan 1:100



Figure 23. Functional box including a loft seen from the side of the kitchen and livingroom. The box configures the different rooms in the apartment.



Figure 24. View from the bedroom towards storage in the corridor, leading to the kitchen and livingroom.

**Snabba hus, Stockholm**  
**Andreas Martin-Löf Arkitekter (2016)**

Snabba Hus Västberga is a project serie designed by Andreas Martin-Löf Arkitekter in 2016. The project utilises prefabrication techniques to provide affordable rental apartments for young people (Rojas, 2017). The apartment buildings achieve sophistication at a low cost through the careful use and adaptation of standardised materials and methods. One of the main walls in the module apartment is made out of built-in furniture, containing the kitchen, wardrobes and a work desk. A built-in bookcase separates the sleeping alcove from the main living space.

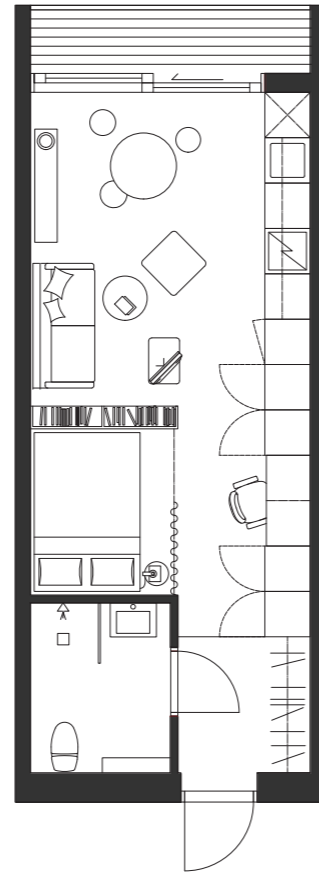

Figure 25. Floor plan 1:100



Figure 26. View of a bookshelf that configures the space for the sleeping alcove and combined kitchen - living room.



Figure 27. View of the functional wall with integrated storage and work desk.

**Shoji Apartment, London**  
**Proctor and Shaw (2021)**

Shoji apartment is a transformation project of a 29 m<sup>2</sup> micro-apartment in London, designed by Proctor and Shaw in 2021 (Astbury, 2022). The apartment has an elevated sleeping space, wrapped in translucent panels, much like the Japanese Shoji screens, hence the name of the project. Two existing interior walls that previously divided the space have been removed to create an open-plan living, kitchen and dining area. The high ceilings generated the concept of "stacking", with the bed on a wooden platform in the corner of the room accessed via a set of wooden steps, creating space for a walk-in wardrobe underneath.

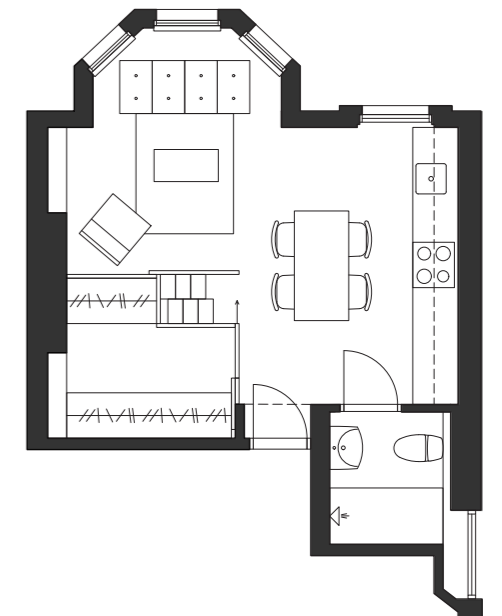

Figure 28. Floor plan 1:100



Figure 29. View of the function box attached to a wall with translucent panels in the sleeping area on the loft.



Figure 30. Kitchen area in same materials as the walls and functional box.

## Analysis of theoretical framework

Learnings from the theoretical framework, mixed with personal ideas, preferences and experience gave important input which created the basis for the final concept and design, aiming to answer the thesis questions. In this section, analysis of the theoretical foundation which made a decisive effect on the design, are briefly presented. Thereafter the results from the design process are presented with subsequent analysis of the design proposals.

United Nations (n.d.) global sustainable development goals are on an overall general level that needs to be interpreted and applied to the design. The aim for a sustainable approach is included by the chosen themes, characteristics and properties that are described in the theoretical framework.

To understand the million programs' significance and extent of possible implementation of this project's final modules, the built quantity of 850 000 apartments (Nylander et al, 2018, p.12), was compared with the current total number of apartments in Sweden (SCB, 2022) which resulted in a share of roughly 30%. The facts of such a large housing stock combined with a need for transformations, emphasised the importance of finding a feasible and alternative solution in the future, where the interior module could be one of them. More recent and already effectively designed apartments from 2010 until today, challenged the design of the interior modules, and were considered to future proof and verify the range of application of the new interior module design.

An important direction during the design phase was to dismiss advanced technical solutions described in Optibo (Boverket, 2004) and solutions that have to be reconfigured continuously during the day brought up by Urist (2013), as they evidently have caused problems and inconvenience to the user.

The idea to focus on small apartments was a challenging task. The contradiction with small apartments requiring less materials making them more sustainable, that on the other hand, are connected with health issues, which makes them unsustainable from another perspective.

Gronostajska and Szczegielniak (2021) brought out the importance of spatial and functional solutions in combination with optical finishing layers that would be possible to embrace during the design phase. Other important ingredients that were considered in the design were the aim for achieving housing qualities raised by both Nylander, O. et al.(2018) and Norwall (2012), and important theories about flexibility as a future proofing tool by Till & Schneider, (2007).

Furthermore, the reference projects in the previous section, showing solutions with distinguished character, that configured different rooms and zones and contained a variety of functions, have had a thorough impact on the design proposals.

When it comes to material for the modules, applying wooden material was an indisputable choice, mainly due to its beneficial factors to health and wellbeing (Häyrynen et al., 2020; Alapieti et al., 2020) and that the use of wood contributes to a lower carbon dioxide emissions in the building sector (Hill, 2019; Svenskt Trä, 2023). On the other hand, no product seems to be perfect from a sustainable perspective. To avoid green washing, it is important for the client to make sure that the wooden material is sourced locally, sourced from a sustainable managed forestry and produced in an energy efficient and environmentally friendly production.

## Design strategy

Throughout the whole design process, several design proposals of interior modules implemented in a variety of floor plans were developed, which consequently resulted in a final design proposal of an interior module. For better understanding of the process, all relevant designs, preliminary and final, are represented in this section followed by an analysis of the result.

In the first section, four of the transformation designs were implemented in already existing apartment floor plans, the framework floor plans, followed by an evaluation of housing qualities. Both the original floor plans and the proposed floor plans from the framework were assessed by MAB's tool.

Secondly, with learnings from the design process, the interior module itself was developed and applied to new apartment floor plans. The new floor plans were graded by the same tool as in the previous stage. The final modules themselves were not evaluated by MAB as it was not possible to apply MAB to an isolated interior item.

### Concept

A design concept on a high level with the following motto was settled:

"Design sustainable, flexible and adaptive interior modules with quality of furniture that divide and configure the space and are equipped for different functions and areas of use. The interior modules can be implemented in a variety of apartment typologies, focusing on small apartments."

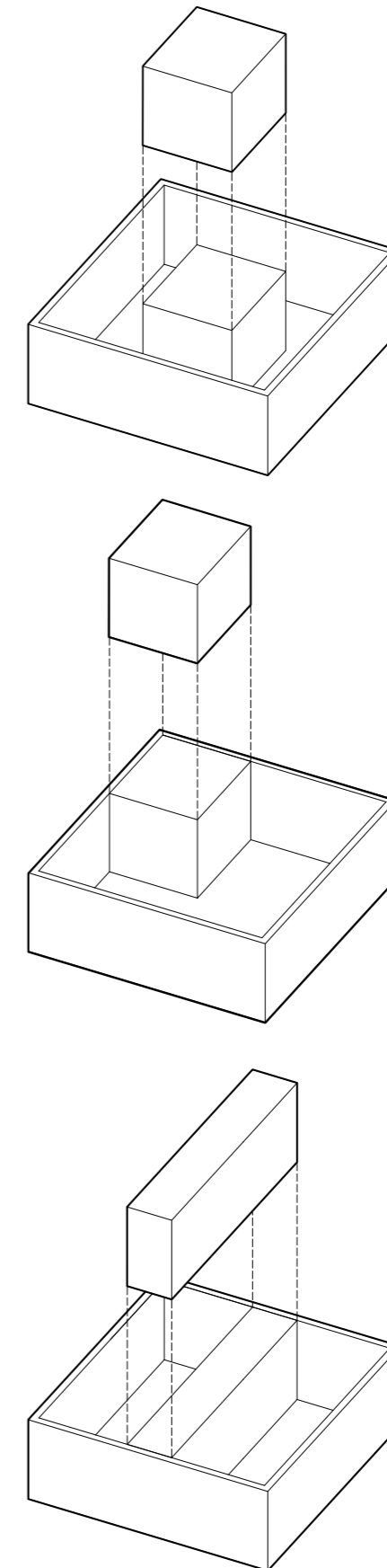

Figure 31. Conceptual diagrams of the placement and spatial configuration of a module within an apartment.

## Explorative design process Transformation of existing apartments

### Introduction to the explorative design

During the first design phase, the explorative design, the focus was on developing different interior module solutions that could be implemented in existing, small, apartments. The framework, meaning the existing floor plans, where interior modules should be implemented, were limited to apartments built during the million homes programme and since 2010. The existing apartment floor plans functioned as a boundary for the design of the interior modules.

Firstly, four different, exploratory types of new interior modules are presented. Thereafter the original floor plans of the apartments are introduced together with the results of the assessment of housing qualities according to MAB. Subsequently, the new interior modules implemented in the existing floor plans are displayed together with the result of MAB assessment of these apartments. The result of the new design itself in combination with a comparison to the result of the original design gave an indication of the accomplishment of the new design regarding housing qualities.

Four different types of interior modules were developed and implemented within the boundary of existing apartments.

The first interior module is designed for central and detached placement which includes technical shaft, bathroom, kitchen, a foldable bed in a sleeping alcove with storage in overhead cabinets. If combined with optional sliding doors, the sleeping alcove can be closed off. The foldable bed can be exchanged with other equipment such as wardrobes, workspace, or a shelving system.

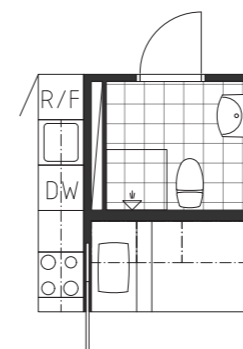

**Figure 32.** Interior module containing bathroom, kitchen, foldable bed, and sliding doors.

The second interior module is a smaller version that mainly consist of storage units. It can be combined in various ways and have central and detached placement. It can include storage, wardrobes, workspace and complement the kitchen with appliances such as a refrigerator and freezer.

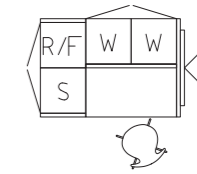

**Figure 33.** Interior module containing storage and workspace.

The third interior module, with similarities to the second module, with the difference that this "functional wall unit" is fitted from wall to wall and floor to ceiling and enclose entire rooms. Panels cover the backside of the storage units where TV and other equipment can be installed. The storage units come in different width, depth, and heights, with different equipment such as wardrobes, shelving systems and overhead cabinets.

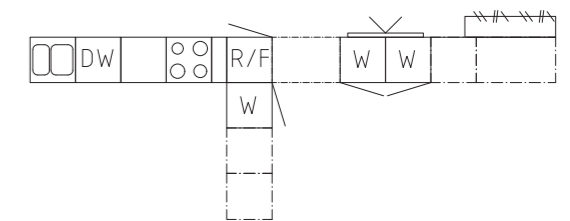

**Figure 34.** Interior module containing kitchen, wardrobes and overhead storage.

The fourth and last interior module, comes with a loft, stairs, bathroom, kitchen, and storage units. It resembles the first interior module but requires a corner attachment in the apartment and double ceiling height.

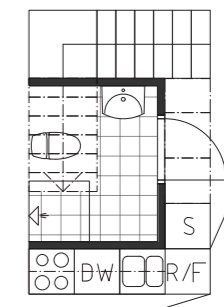

**Figure 35.** Interior module containing bathroom, kitchen, storage, and staircase.

# Explorative design process

## Gropegårdsgatan, Rambergstaden (1972)

### Original design

Two-room apartment of 52 m<sup>2</sup>

The original floor plan has a core with a hallway, bathroom, kitchen, and two adjacent rooms on each side. The bathroom is not accessible according to today's standards. It is a quite wide and single-sided apartment, creating narrow and deep rooms. The small kitchen with parallel layout does not fit a dining table, but works as a connection between the two main rooms, making circulation possible.

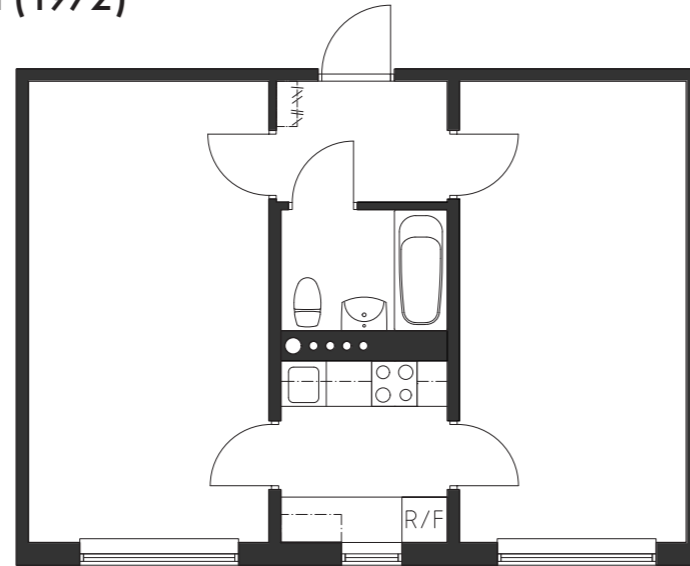

Figure 36. Original floor plan. 1:100

### MAB Analysis

Examples from the assessment of the MAB analysis:

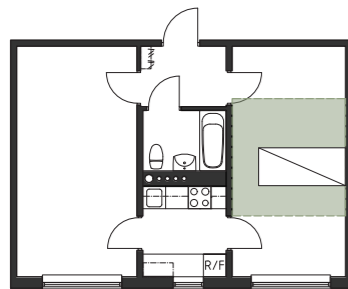

Figure 37. Functionality  
Eg: Bedroom capacity.

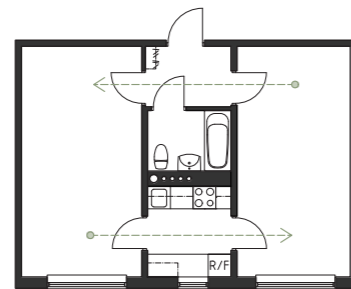

Figure 38. Spaciousness  
Eg: Axiality.

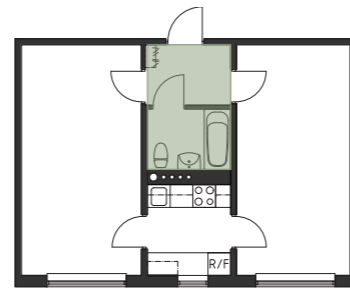

Figure 39. Atmosphere  
Eg: Dark space. 1:200

Final grading of the MAB assessment:

Total grade	Aspect grade	Quality
Silver	Functionality	1. Space efficiency <input type="radio"/>
		2. Furnishable space <input checked="" type="radio"/>
		3. Technical rationality <input type="radio"/>
		4. Potential for home care <input checked="" type="radio"/>
	Spaciousness	5. Axiality <input checked="" type="radio"/>
		6. Circulation <input checked="" type="radio"/>
		7. Room shape <input checked="" type="radio"/>
		8. Flexibility <input checked="" type="radio"/>
	Atmosphere	9. Multiple facade directions <input type="radio"/>
		10. Balcony <input type="radio"/>
		11. Daylight <input type="radio"/>
		12. Dark space <input checked="" type="radio"/>

Table 1. MAB result of the original floor plan.

### New design

Two and half-room apartment of 52 m<sup>2</sup>

The new floor plan with a centred interior module, contains an accessible bathroom, open floor plan, sleeping alcove with a foldable bed and sliding doors for privacy. The interior module is made of plywood in green colour that accentuates the module from the rest of the apartment interior. The floor plan creates an enfilade with axiality and sightlines through three rooms. Circulation around the module can be cut off with sliding doors, creating separate rooms.

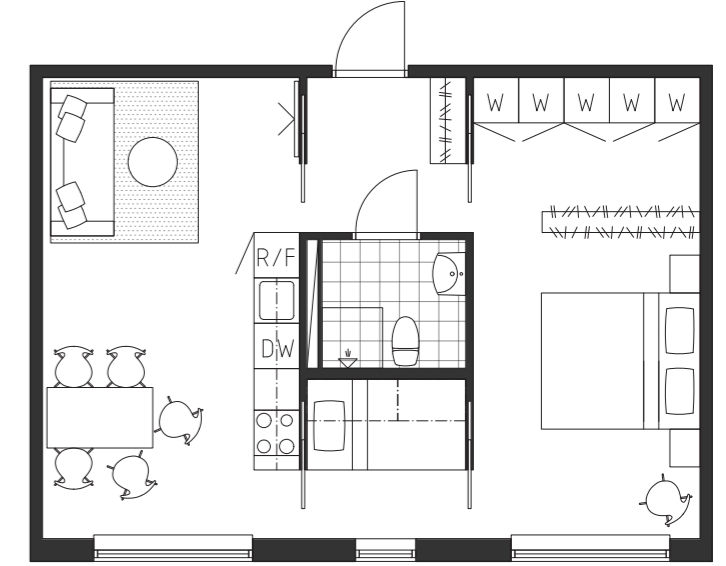

Figure 40. Transformed floor plan. 1:100

### MAB Analysis

Examples from the assessment of the MAB analysis:



Figure 41. Functionality  
Eg: Bedroom capacity.



Figure 42. Spaciousness  
Eg: Axiality.

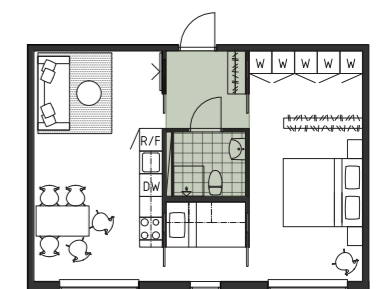

Figure 43. Atmosphere  
Eg: Dark space. 1:200

Final grading of the MAB assessment:

Total grade	Aspect grade	Quality
Silver	Functionality	1. Space efficiency <input type="radio"/>
		2. Furnishable space <input checked="" type="radio"/>
		3. Technical rationality <input type="radio"/>
		4. Potential for home care <input checked="" type="radio"/>
	Spaciousness	5. Axiality <input checked="" type="radio"/>
		6. Circulation <input checked="" type="radio"/>
		7. Room shape <input checked="" type="radio"/>
		8. Flexibility <input checked="" type="radio"/>
	Atmosphere	9. Multiple facade directions <input type="radio"/>
		10. Balcony <input type="radio"/>
		11. Daylight <input type="radio"/>
		12. Dark space <input checked="" type="radio"/>

Table 2. MAB result of the proposed floor plan.



Figure 44. The perspective demonstrates the style, materials, colours, and ambience of the transformed design.

## Topasgatan, Västra Frölunda (1965)

### Original design

Two-room apartment of 43 m<sup>2</sup>

In the original floor plan, the core with the hallway, the kitchen and bathroom is situated in the darker area, at the back of the apartment. In general narrow rooms with circulation through three rooms. It is not possible to fit a double-bed in the bedroom that is situated between the living room and kitchen. The kitchen has an angled layout with a small dining space.

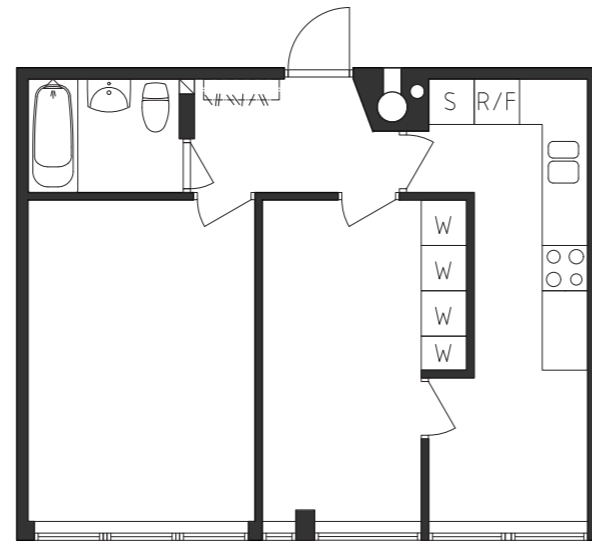

Figure 45. Original floor plan. 1:100

### MAB Analysis

Examples from the assessment of the MAB analysis:

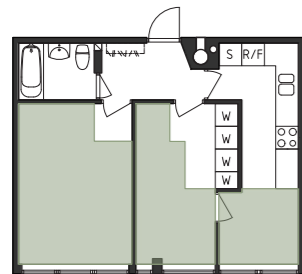

Figure 46. Functionality  
Eg: Furnishable space.

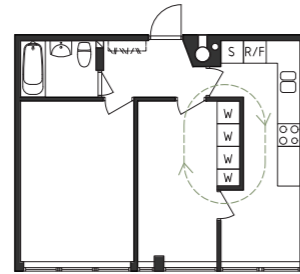

Figure 47. Spaciousness  
Eg: Circulation.

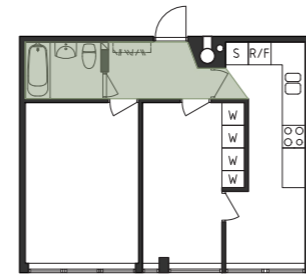

Figure 48. Atmosphere 1:200  
Eg: Dark space.

Final grading of the MAB assessment:

Total grade	Aspect grade	Quality
Failed	Functionality	1. Space efficiency ●
		2. Furnishable space ●
		3. Technical rationality ●
		4. Potential for home care ●
	Spaciousness	5. Axiality ●
		6. Circulation ●
		7. Room shape ●
		8. Flexibility ●
	Atmosphere	9. Multiple facade directions ○
		10. Balcony ○
		11. Daylight ○
		12. Dark space ○

Table 3. MAB result of the original floor plan.

### New design

One and a half-room apartment of 43 m<sup>2</sup>

The new design has a central interior module, with functions on all four sides, divides the space into different zones. It contains wardrobes, kitchen appliances, work space, and wall for a TV. A second module is configured with wardrobes and sliding doors for possible separation of the sleeping alcove. Bathroom and kitchen are connected and shares a technical shaft. The floor plan creates an enfilade with axiality and sightlines through three zones. A pink coloured plywood, accentuates the interior module within the space.

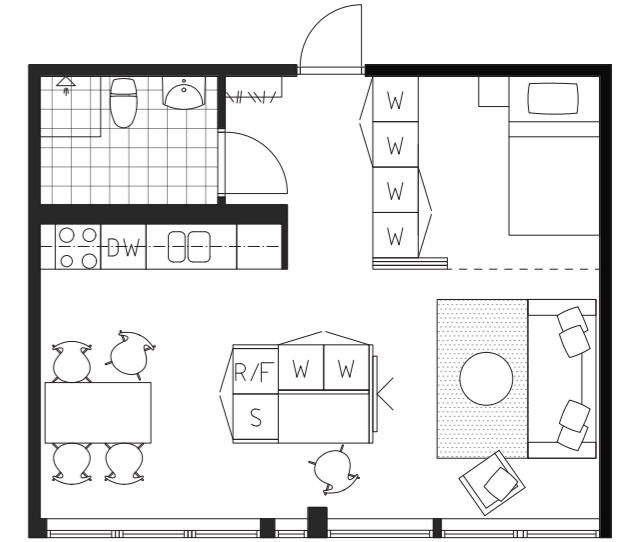

Figure 49. Transformed floor plan. 1:100

### MAB Analysis

Examples from the assessment of the MAB analysis:

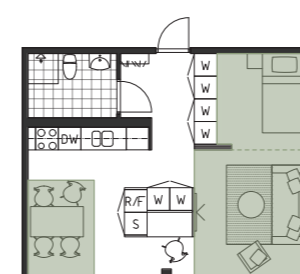

Figure 50. Functionality  
Eg: Furnishable space.



Figure 51. Spaciousness  
Eg: Circulation.

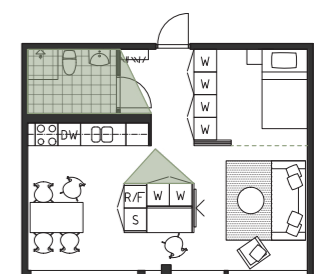

Figure 52. Atmosphere 1:200  
Eg: Dark space.

Final grading of the MAB assessment:

Total grade	Aspect grade	Quality
Silver	Functionality	1. Space efficiency ○
		2. Furnishable space ○
		3. Technical rationality ●
		4. Potential for home care ●
	Spaciousness	5. Axiality ●
		6. Circulation ●
		7. Room shape ●
		8. Flexibility ○
	Atmosphere	9. Multiple facade directions ○
		10. Balcony ○
		11. Daylight ○
		12. Dark space ●

Table 4. MAB result of the proposed floor plan.



Figure 53. The perspective demonstrates the style, materials, colours and ambiance of the transformed design.

## Äppelträdgården, Västra Frölunda (2019)

### Original design

One-room apartment of 36 m<sup>2</sup>

The original floor plan is multi-sided, with direct outdoor access. It consists of one large living space with a bathroom situated in one corner. The bathroom has a window and a washer/dryer. Kitchen and wardrobes creates a functional wall at the short end. A small sleeping alcove is situated behind the bathroom.

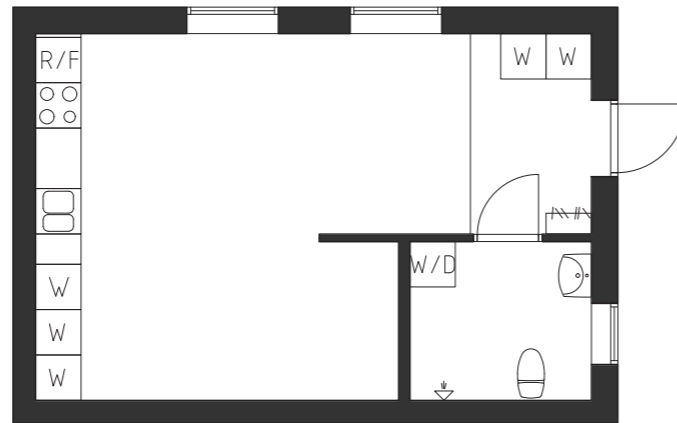

Figure 54. Original floor plan.

1:100

### MAB Analysis

Examples from the assessment of the MAB analysis:

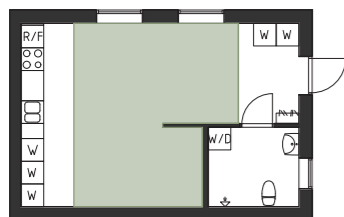

Figure 55. Functionality  
Eg: Furnishable space.

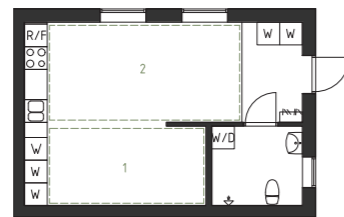

Figure 56. Spaciousness  
Eg: Room shape.

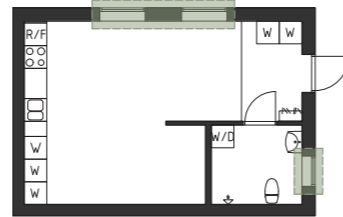

Figure 57. Spaciousness  
Eg: Multi-sided apartment.

1:200

### Final grading of the MAB assessment:

Total grade	Aspect grade	Quality
Bronze	Functionality	1. Space efficiency ○
		2. Furnishable space ●
		3. Technical rationality ●
		4. Potential for home care ○
	Spaciousness	5. Axiality ○
		6. Circulation ○
		7. Room shape ●
		8. Flexibility ○
	Atmosphere	9. Multiple facade directions ●
		10. Balcony ○
		11. Daylight ○
		12. Dark space ●

Table 5. MAB result of the original floor plan.

35

### New design

Two-room apartment of 36 m<sup>2</sup>

In the new design, the module divides the space into two rooms, with a separate bedroom. The module goes from floor to ceiling, utilising space over door opening and the bed. The module gives the appearance of a thick wall, creating a deep doorway and niche for the bed. A yellow colour accentuates the module from the rest of the apartment interior. Bathroom is situated in a dark corner, and the separate bedroom has daylight access. Kitchen and bathroom share a technical shaft.

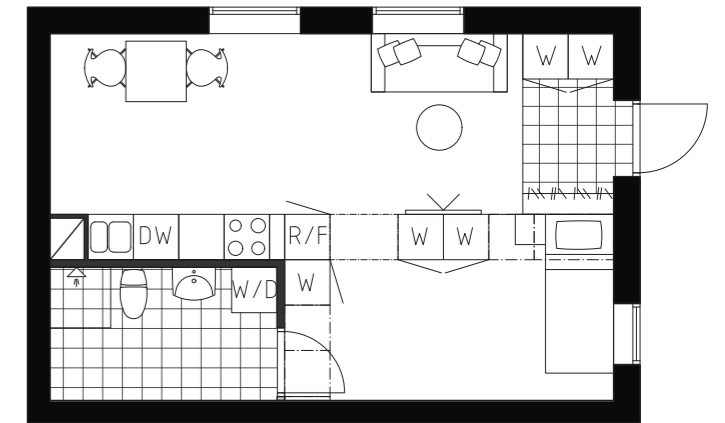

Figure 58. Transformed floor plan.

1:100

### MAB Analysis

Examples from the assessment of the MAB analysis:



Figure 59. Functionality  
Eg: Furnishable space.

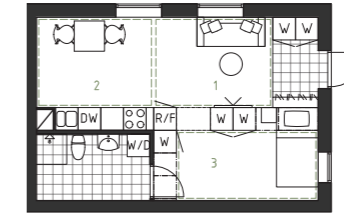

Figure 60. Spaciousness  
Eg: Room shape.

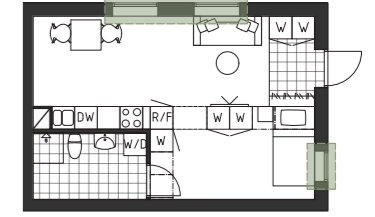

Figure 61. Spaciousness  
Eg: Multi-sided apartment.

1:200

### Final grading of the MAB assessment:

Total grade	Aspect grade	Quality
Silver	Functionality	1. Space efficiency ●
		2. Furnishable space ●
		3. Technical rationality ●
		4. Potential for home care ○
	Spaciousness	5. Axiality ●
		6. Circulation ○
		7. Room shape ●
		8. Flexibility ○
	Atmosphere	9. Multiple facade directions ●
		10. Balcony ○
		11. Daylight ○
		12. Dark space ●

Table 6. MAB result of the original floor plan.

36



Figure 62. The perspective demonstrates the style, materials, colours and ambience of the transformed design.

## Smedjan, Lindholmen (remodelled in 2018)

### Original design

One-room apartment 29 m<sup>2</sup> + loft

The original, remodelled apartment has a full-height loft that is reached by a spiral staircase in the combined living room, kitchen and sleeping alcove. The bathroom is in the dark part of the apartment, opposite to a functional wall with kitchen and wardrobes. The first floor has a sleeping alcove for a single-bed and large space for a double-bed and wardrobes on the loft.

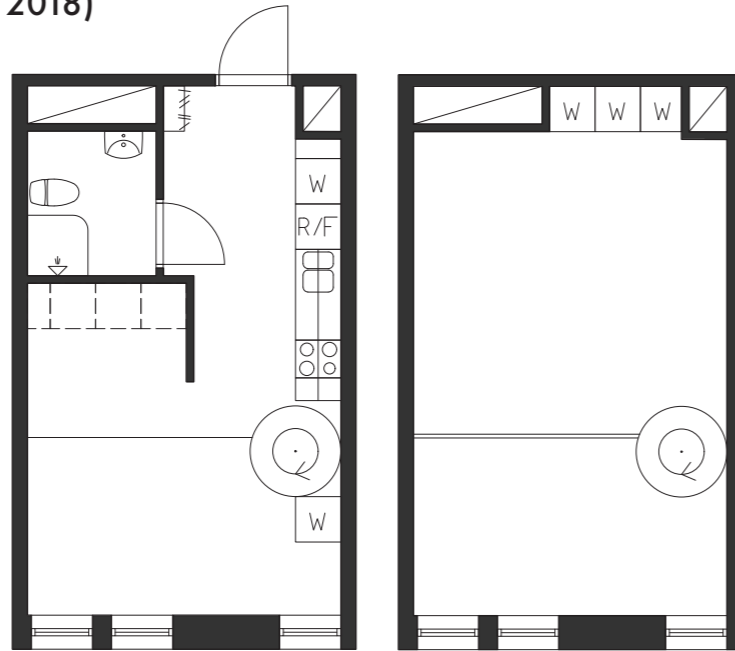

Figure 63. Original floor plans. 1:100

### MAB Analysis

Examples from the assessment of the MAB analysis:

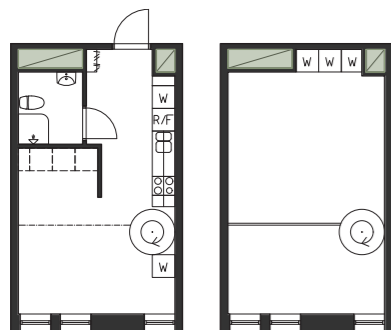

Figure 64. Functionality  
Eg: Technical rationality.

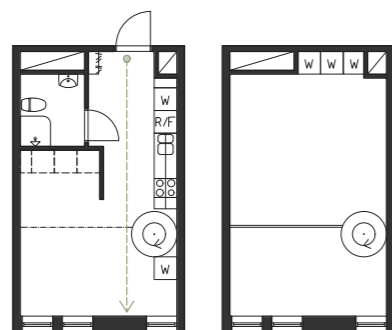

Figure 65. Spaciousness  
Eg: Axiality.

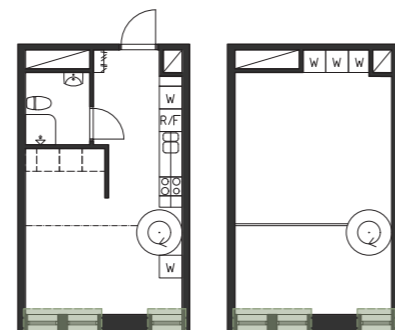

Figure 66. Atmosphere  
Eg: Daylight (Large windows). 1:200

Final grading of the MAB assessment:

Total grade	Aspect grade	Quality
Silver	Functionality	1. Space efficiency ●
		2. Furnishable space ●
		3. Technical rationality ●
		4. Potential for home care ○
	Spaciousness	5. Axiality ●
		6. Circulation ○
		7. Room shape ○
		8. Flexibility ○
	Atmosphere	9. Multiple facade directions ●
		10. Balcony ○
		11. Daylight ●
		12. Dark space ●

Table 7. MAB result of the original floor plan.

### New design

One-room apartment 29 m<sup>2</sup> + loft

A divergent colour accentuates the interior module from the rest of the apartment interior, including an integrated staircase. The module underlines where the space goes from single to double ceiling height. The kitchen is situated on the other side of the bathroom wall. An integrated staircase in the entrance leads directly up to the loft. Opposite of the bathroom, a functional wall includes wardrobes and a built-in workspace.

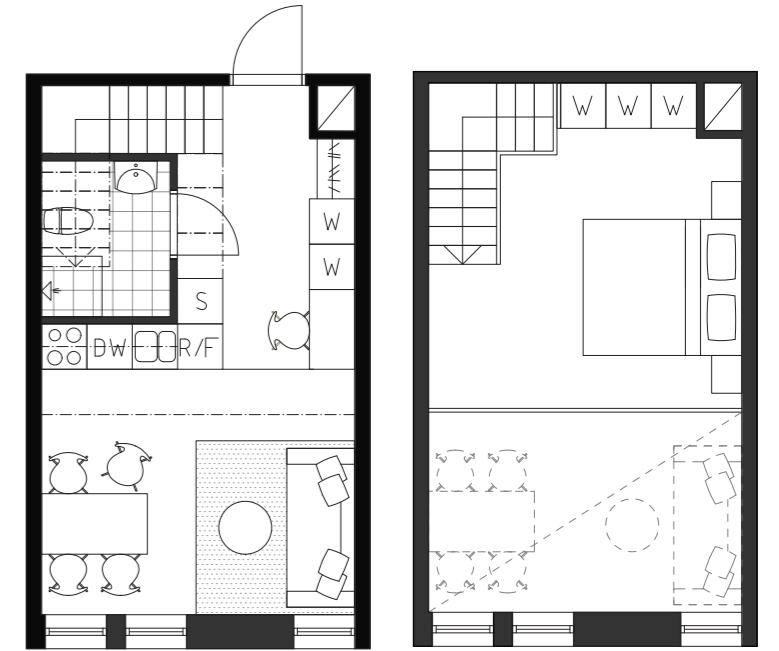

Figure 67. Transformed floor plans. 1:100

### MAB Analysis

Examples from the assessment of the MAB analysis:

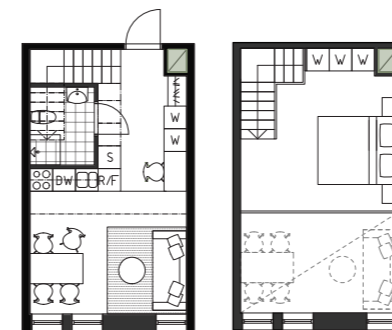

Figure 68. Functionality  
Eg: Technical rationality.

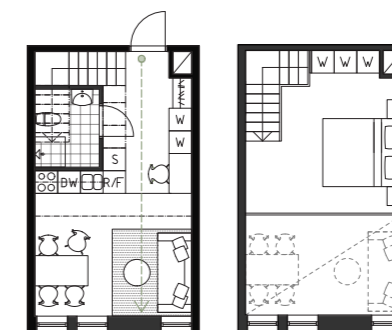

Figure 69. Spaciousness  
Eg: Axiality.

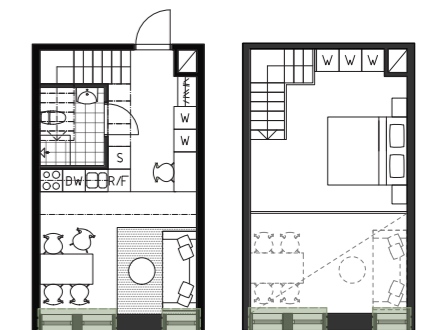

Figure 70. Atmosphere  
Eg: Daylight (Large windows). 1:200

Final grading of the MAB assessment:

Total grade	Aspect grade	Quality
Silver	Functionality	1. Space efficiency ●
		2. Furnishable space ●
		3. Technical rationality ●
		4. Potential for home care ○
	Spaciousness	5. Axiality ●
		6. Circulation ○
		7. Room shape ○
		8. Flexibility ○
	Atmosphere	9. Multiple facade directions ●
		10. Balcony ○
		11. Daylight ●
		12. Dark space ●

Table 8. MAB result of the original floor plan.



Figure 71. The perspective demonstrates the style, materials, colours and ambience of the transformed design.



Figure 72. Interior of Gropegårdgatan, showing sleeping alcove.



Figure 73. Interior of Topasgatan, showing interior module with workspace.



Figure 74. Interior of Äppelträdgården, showing module separating bedroom.

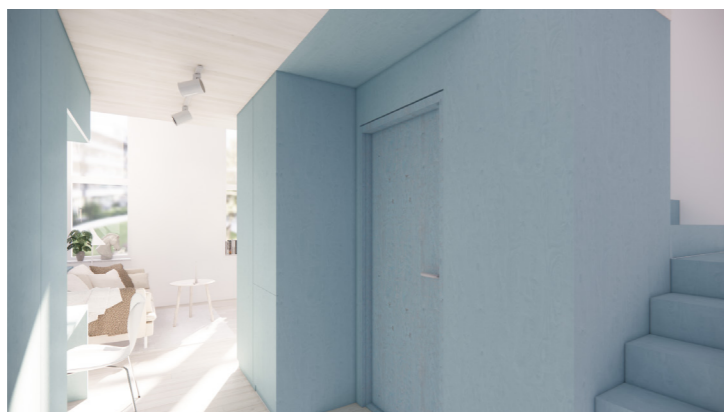

Figure 75. Interior of Smedjan, showing interior module with integrated staircase.

## Analysis of the explorative design process

As the housing qualities of the interior module itself cannot be evaluated by the MAB analysis tool, some findings were found important to highlight and bring into the next design phase. The four different interior modules included similar functions such as storage, wardrobes, shelving system, foldable bed, workspace and sliding doors, whereas two solutions also include bathroom and kitchen. To solve a functional apartment floor plan, sometimes two types of interior modules were combined. The analysis of the explorative design engaged to come up with one adaptable final design solution that should include all these functions and features that were concluded both essential, necessary, smart, and desirable in a small apartment. As there is a variation of ceiling heights, the interior module requires adaptability in height and needs exchangeable equipment and functions.

Before applying any evaluation tool measuring qualities, and just by relying on personal experience, the chosen original floor plans appeared quite well planned with good spatial and housing qualities in general. For the apartments built during the millions homes programme, they all were not accessible according to today's standard, whereas the design as is, cannot be duplicated.

When comparing the original floor plans with the new design proposals in MAB, the new floor plans with the module have variations of resemblance to the original, but resulted in the same or better score. Two developed floor plans proposals had the same result as the originals, and two developed floor plans obtained better scores.

The differences in between the original floor plan and the new proposal were variations in furnishable space (space around built-in elements are not furnishable), space efficiency (transforming the apartment from a two rooms to one room apartment), flexibility (no neutral hallway connecting to other rooms) dark space (possible with daylight access with modules). Some qualities such as flexibility stood out to be difficult to fulfil with small size apartments.

Valuable qualities, characteristics and components such as accessible bathroom, the possibility to fit an extra bedroom in the same space, or the ambience created by material choice in the new module were not considered and scored in MAB. The MAB analysis tool was not fully applicable for evaluating the apartments themselves, nor suitable for the proposed modules themselves, but served as a conductive and governing indicator during the design process.

## Design proposal The Living Box

## Introduction to the design proposal

During the second design phase, the final design proposal of the interior module, the Living Box, with its subsequent implementation in apartment floor plans was developed.

Learnings from the previous explorative design phase which were brought up in the previous analysis, were considered in the final design proposal. The focus was on one adaptable interior module including smart, essential, and interchangeable functions that generates free space and support adaptability by generality and flexibility in the apartments.

Firstly, the interior modules in different configurations are presented thoroughly. Thereafter the interior modules, the Living Boxes, are implemented and displayed in new apartment floor plans. The housing qualities of the apartments were then assessed using the MAB tool followed by an analysis of the final design proposals.

## Interior module

The interior module is based on the concept of being the main room-dividing and spatial configurational element of an apartment. The module consists of a technical shaft in the middle where the essential functions such as kitchen, bathroom and storage are concentrated in a functional interior module.

The interior modules could be dimensioned to function as the structural load bearing elements that are stacked on top of each other. When implementing the interior module in a completely new building, the modules are planned to be prefabricated in cross laminated timber (CLT), if justifiably from various aspects such as sustainability, economics and site-specific conditions. The interior module as a load bearing element, is on an idea-level only and has not been developed in detail, in line with the delimitations of the thesis.

An alternative to prefabricated CLT modules is the more conventional wooden stud- and beam construction in combination with recycled boards (see figure 10), with or without plywood boards as finishing layer. The use of prefabricated and assembled CLT modules is limited in for example transformation projects of existing apartments where the access points for material to the apartments sets the limits for size of material.

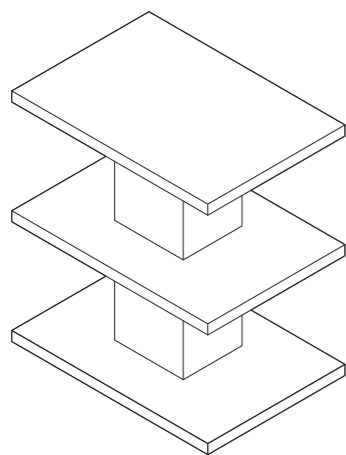

Figure 76. Concept diagram for stacking the load bearing interior modules.

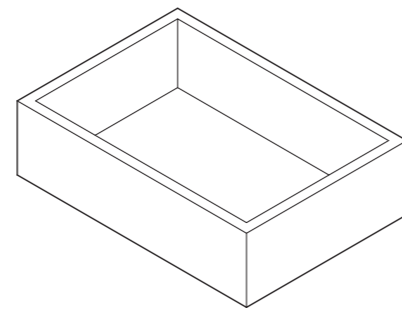

Figure 77. Concept diagram of the boundaries.

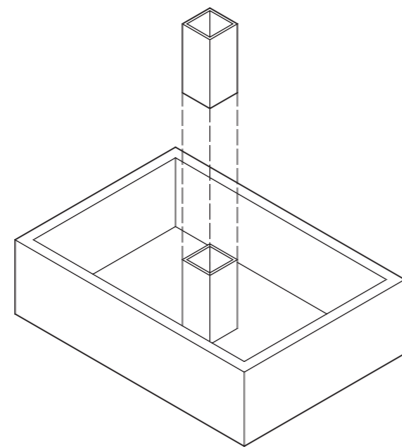

Figure 78. Concept diagram of technical shaft.

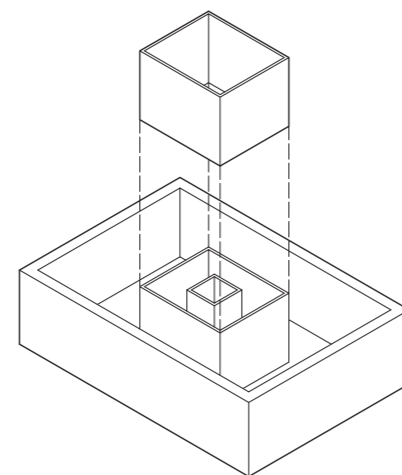

Figure 79. Concept diagram of the essential functions creating the spatial configuration.

On top of the CLT, the finishing layer is exchangeable with panels in plywood that are treated with linseed oil (see figure 11-14) in transparent or a range of different colours. Plywood with mirrors in recyclable acrylic plastic is also available and can be applied to certain areas on the interior module to obtain optical effects that improve the experience of the space. This selection of finishing colours and finishing material on the panels gives the end-user more possibility to choose a finishing layer according to their own personal preferences, that at the same time facilitate easy and fast exchange or reconditioning after wear and tear. The possibility to exchange and recondition the panels, is based on an idea to develop a product logistic system that handles the exchangeable items if the modules are implemented to a certain extent. In case of small scale or initial implementation, it could be handled by local establishments.

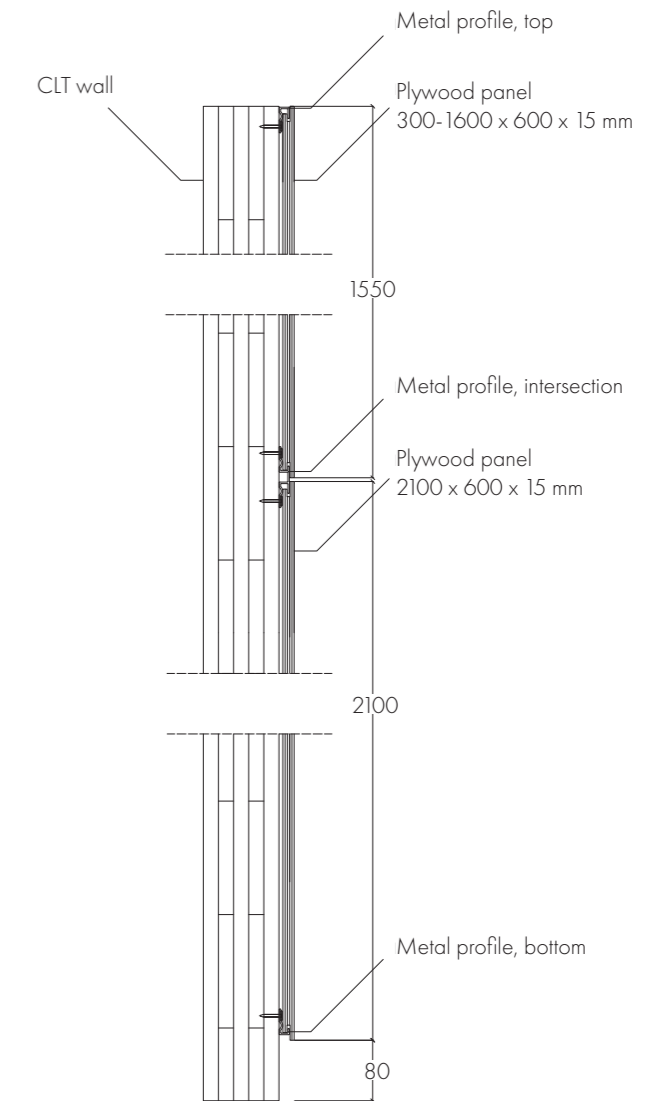

Figure 80. Detail drawing of panel fastening system.

1:10

## The Living Box I

The interior module is designed to be adaptable with exchangeable parts, and is designed in two different versions. The first version of the module is called Living Box I, and is designed to be implemented into new buildings or transformation projects with the option of higher ceilings. Minimum height of the interior module is 3700 mm with a footprint of 3200 x 3000 mm. This interior module contains a staircase to a sleeping loft, with storage underneath the stairs that can be configured with drawers, cabinets, shelves, foldable iron board and mirrors. To be comfortable and function well, the minimum height of the sleeping loft is 1300 mm. The kitchen is quite small with a countertop length of 2400 mm, approved by the Swedish design standards. Measuring 1700 x 1900 mm, the bathroom is also designed according to standards.

The design of the module is only slightly different if the module is placed along an apartment wall, or placed in the centre of an apartment. Instead of a storage cabinet facing a room along the short side of the module, the cabinet is opened from the bathroom.

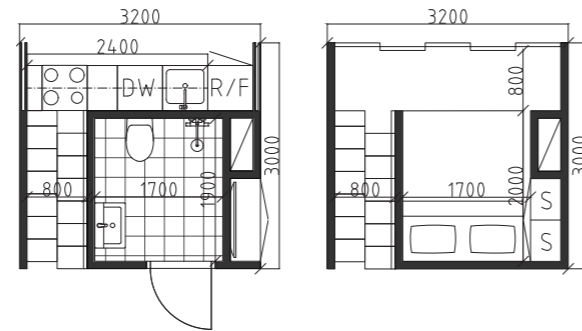

Figure 81. Floor plan of module with sleeping loft.

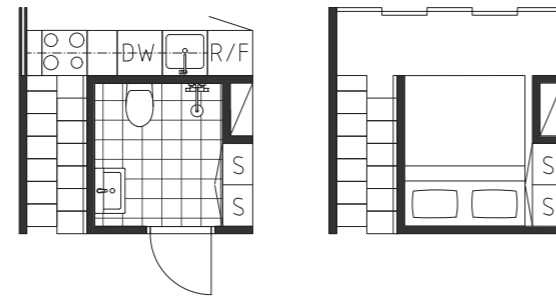

Figure 82. Floor plan of module with loft, placed along an apartment wall. 1:100



Figures 83,84. Physical model built in scale 1:20.

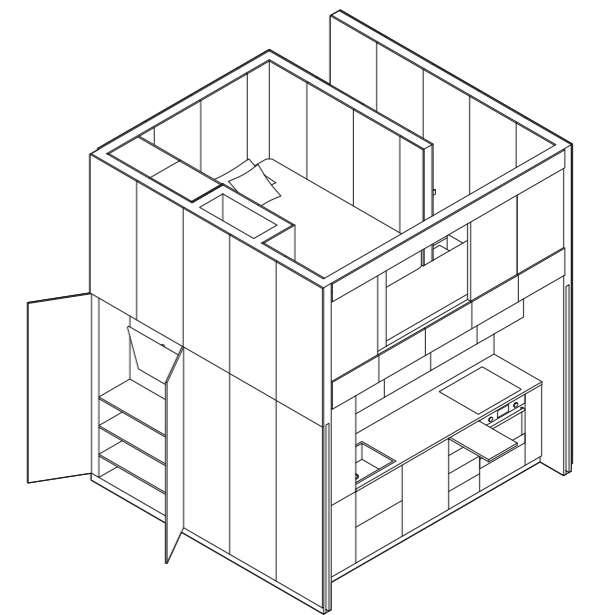
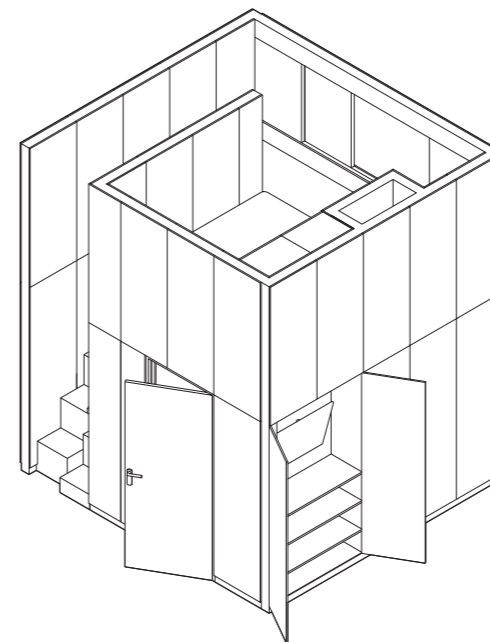
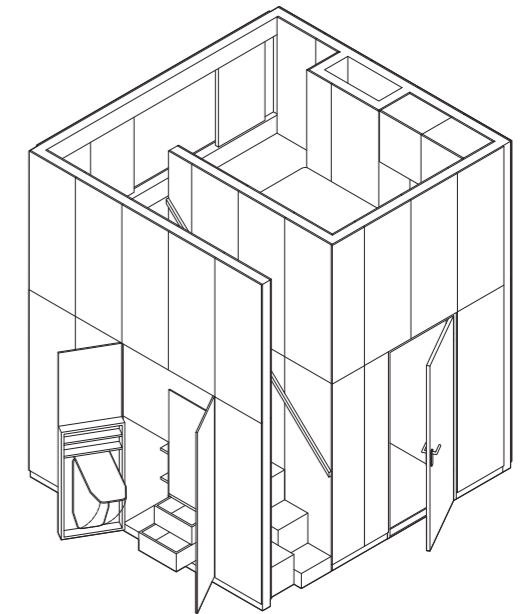
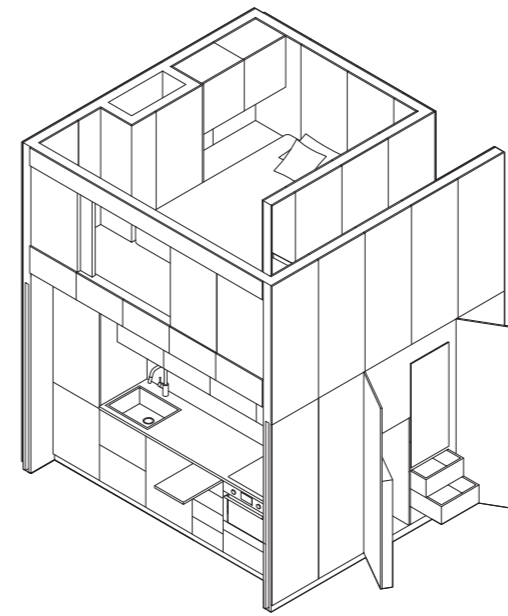

Figure 85. Isometric view of Living Box I, no scale.

## Finishing materials

Wood is the dominating material of the Living Box, with a few additional materials, chosen for their aesthetic qualities, durability, and more neutral characteristic to withstand short trends over time. The exchangeable cladding material is plywood panels that are treated with linseed oil, either transparent or tinted shade.

The panels can also be made of recycled boards or mirrors, depending on the users' preferences and type of project. Kitchen backsplash and countertop is made of terrazzo and bathroom flooring and walls in ceramic tiles. The loft floor has fir plank flooring that can be reconditioned many times after wear and tear.

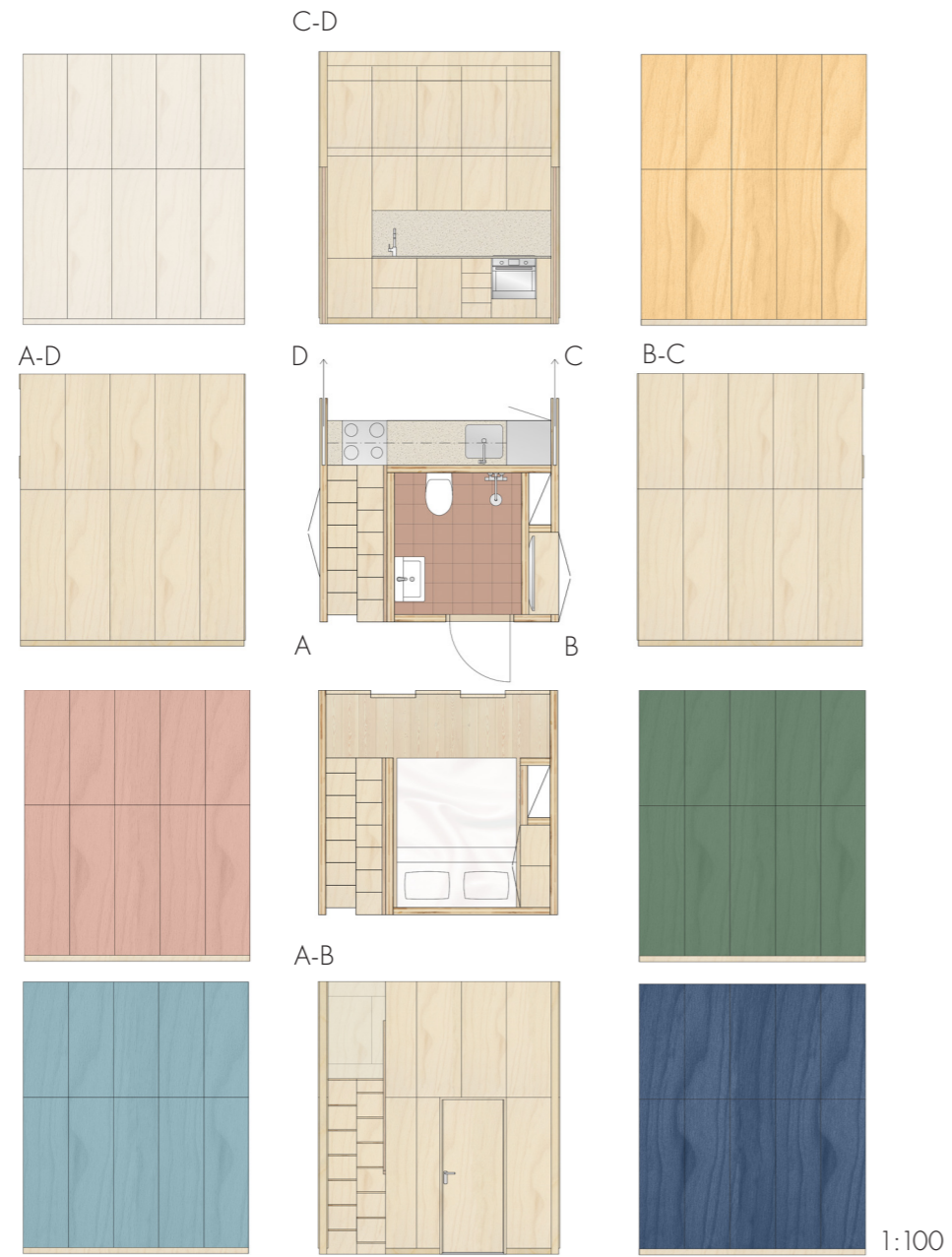
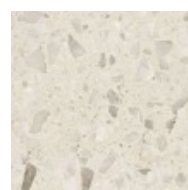

Figure 86. Floor plan and elevation with material samples for the plywood panels, Living Box I.



Terrazzo



Fir plank flooring



Ceramic tile

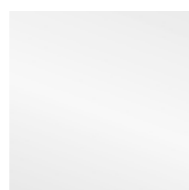

Mirror

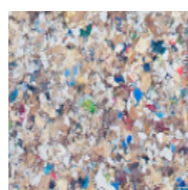

Recycled board

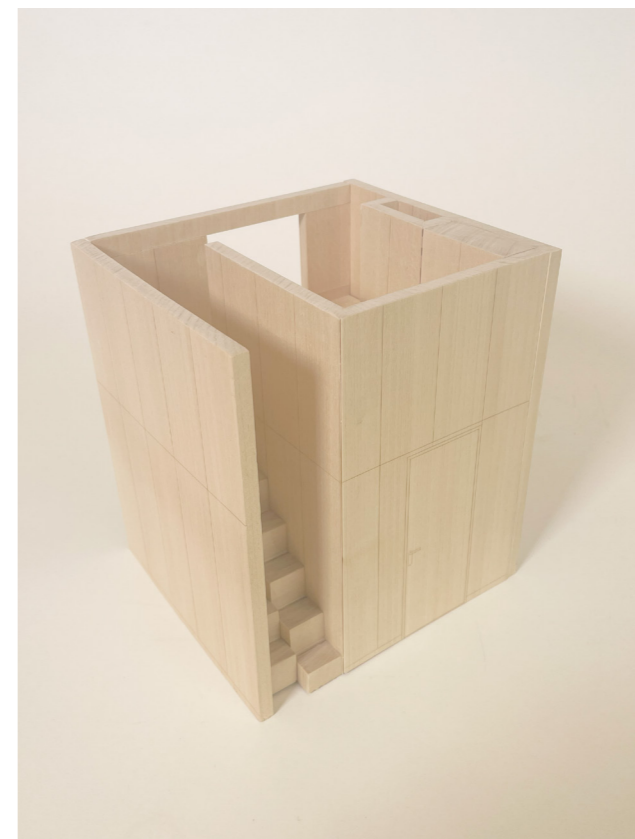

Figure 87, 88. Physical model built in scale 1:20.

## The Living Box II

If sleeping loft is not possible due to ceiling height limitations the second version of the interior module Living Box II has a total height of minimum standard 2,4 meters, making it possible to implement in various apartment buildings with different ceiling height. The interior module can be used in both existing apartments and new apartment buildings. This design does not include a staircase and sleeping loft, instead the module contains either a foldable bed, workspace or walk-in closet.

The concept is that the integrated objects can be exchanged based on the measurements of the apartment, designation of the space and on tenants needs. The chosen integrated object can easily be covered with a foldable door, giving the module an integrated look. The adaptable part gives the space a flexible use and a possibility of personalisation of the space. For instance, the foldable bed could be a good option for tenants living in an one-room apartment, as it facilitates more space when its folded and not in use.

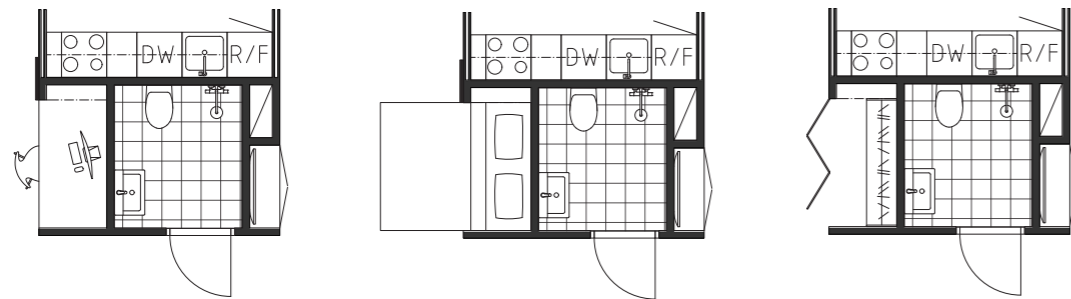

Figure 89. Floor plan of different versions of the Living Box II.

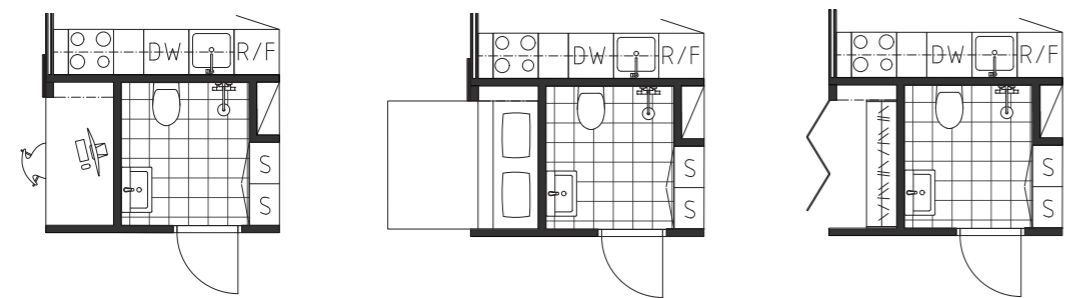

Figure 90. Floor plan of interior module placed along an apartment wall.

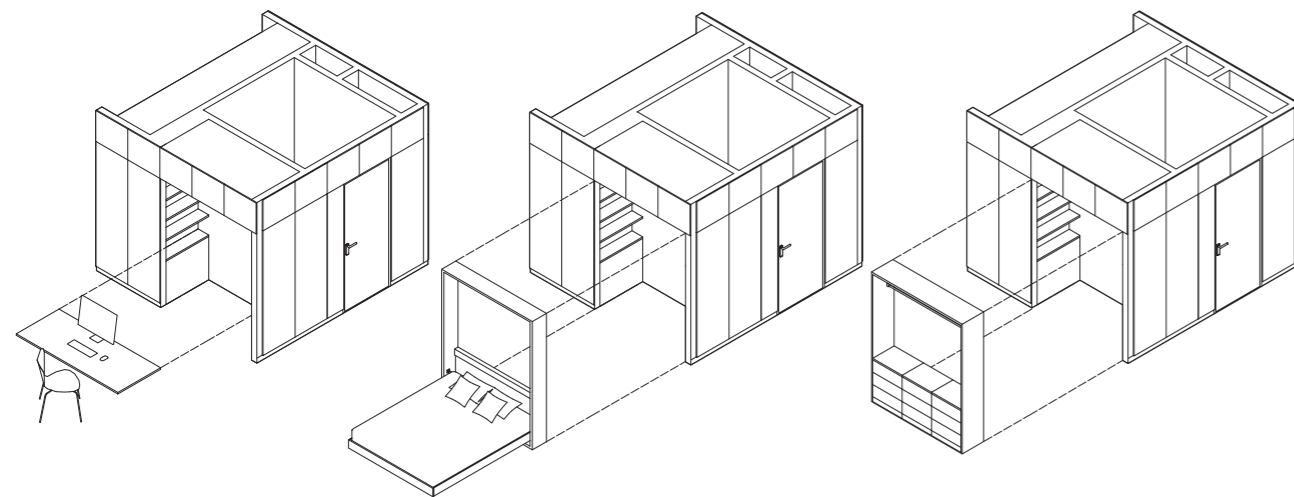

Figure 91. Isometric view of different objects, implemented in Living Box II.

1:100

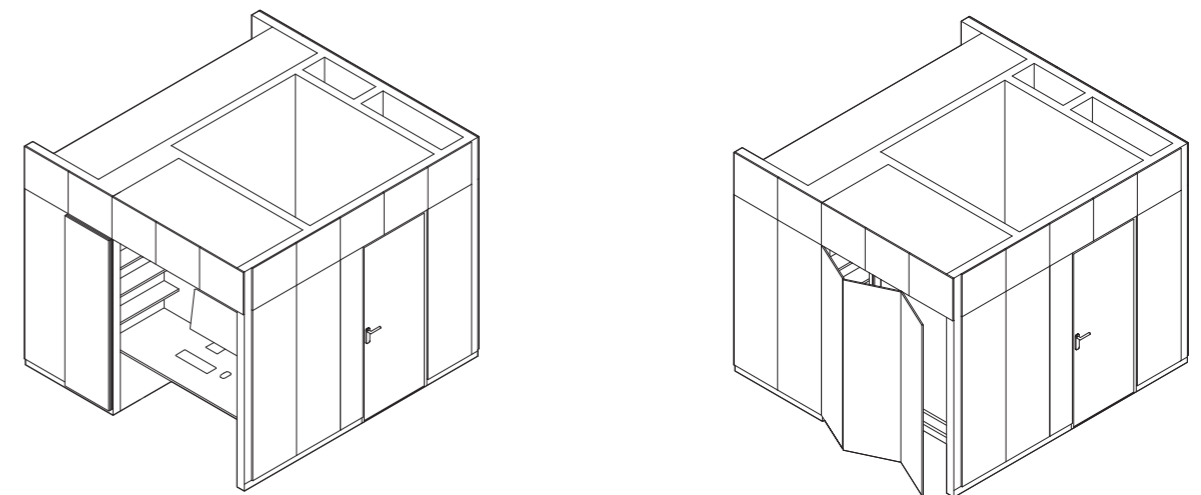
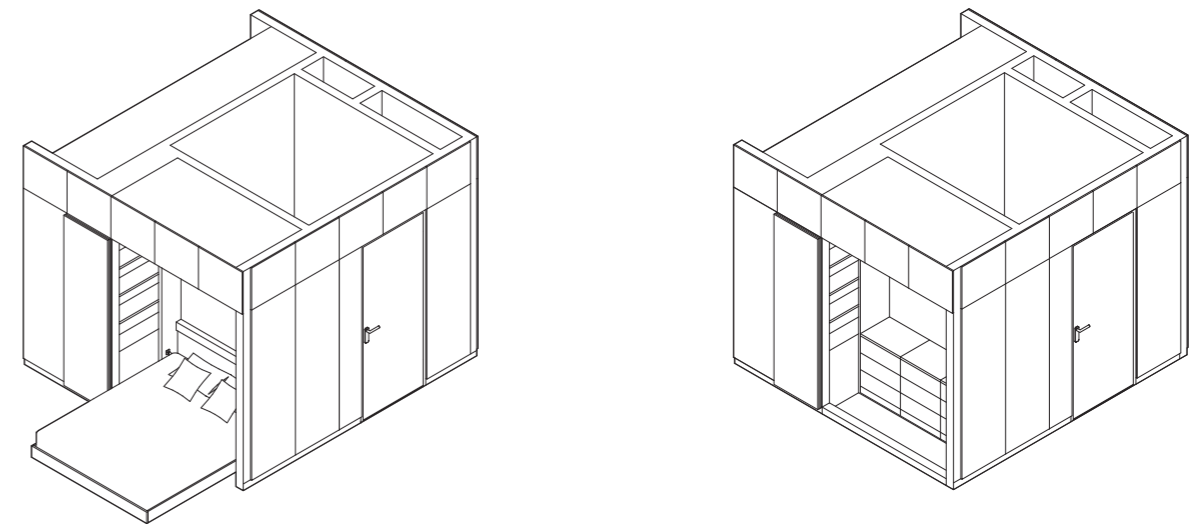

Figure 92. Isometric view of the Living Box II with different integrated objects.

## Finishing materials

The Living Box II without a loft, naturally comes with the same finishing materials for the same reasons as the configuration with loft. A lower height results in different size of the top panels giving a slight different characteristics to the interior module.

In comparison with the Living Box I, the lack of a staircase in combination with foldable doors, express an even more solid interior module that hides a variety of functions.

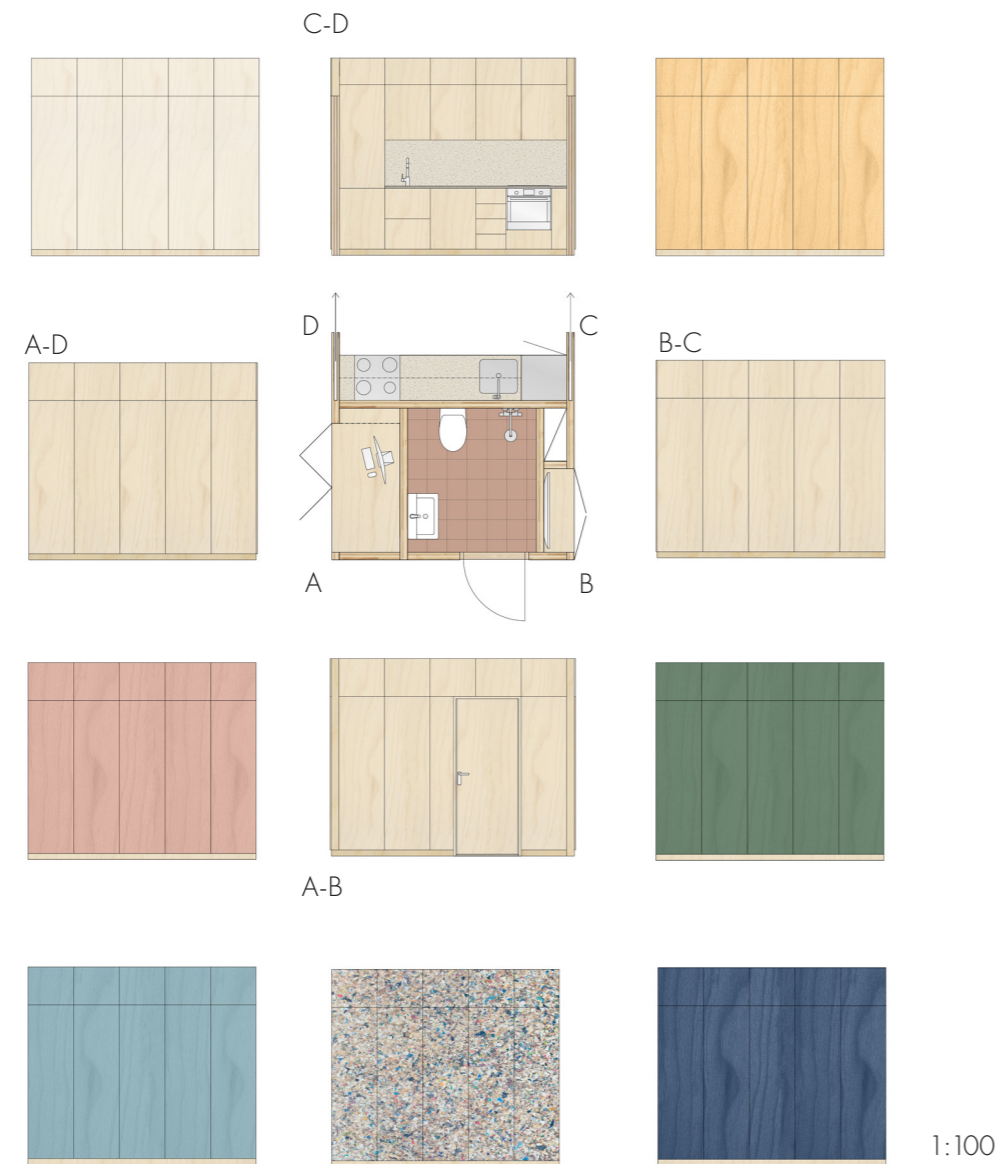
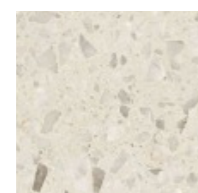

Figure 93. Floor plan and elevation with material samples for the panels, Living Box II.



Terrazzo



Ceramic tile

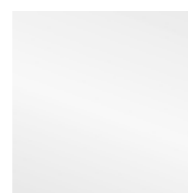

Mirror



Figure 94. Physical concept model built in scale 1:50.

## The apartments

The design proposals are based on the concept with outer boundaries, the apartment dividing walls, with a technical shaft in the middle. Essential functions such as kitchen, bathroom, storage and staircase to a loft, if applicable, are concentrated in an interior module. An option is to add dividing walls with sliding doors, in order to obtain privacy and flexibility.

The interior module configures the space in two identical and general rooms, into a two-room apartment of 55 m<sup>2</sup>, within the boundaries whose designation and use can freely be decided by the user. To create a one-room apartment, one of the rooms is disconnected, whereas the interior module is placed attached to the apartment dividing wall, creating an apartment of 36 m<sup>2</sup>.

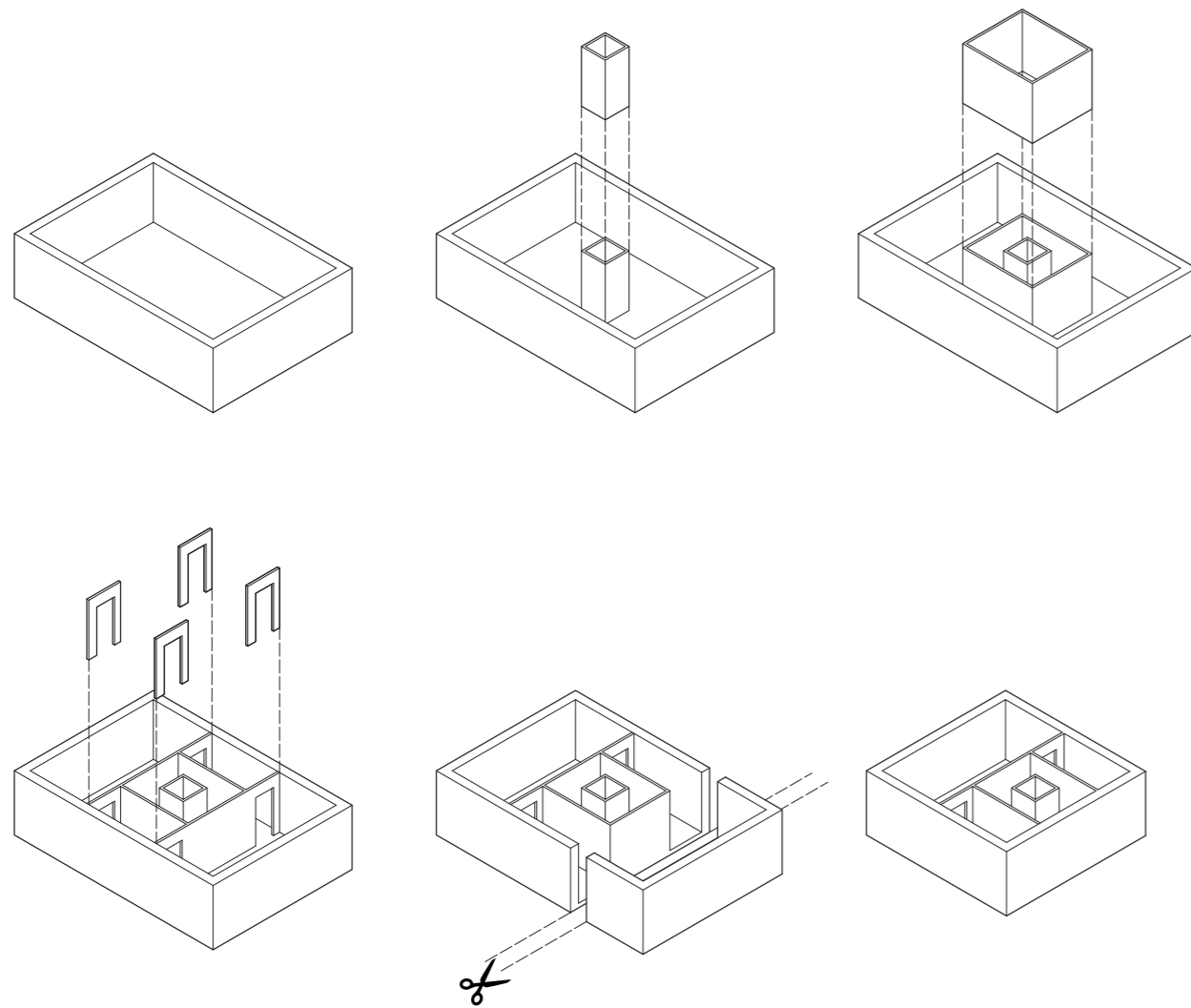

Figure 95. Conceptual diagrams of the apartment configuration.

The two different sizes of apartments with one or two rooms are equipped with identical interior modules. These apartments can be combined to configure a residential building that contains four different small apartments, as some floors can have apartments with or without lofts.

The apartments can be configured for both indoor entrance in tower block and lamella buildings or with exterior entrance by access balcony with daylight from opposite directions. Below drawings show possible combinations of apartments for both types of apartment buildings, which naturally can be changed to other combinations.

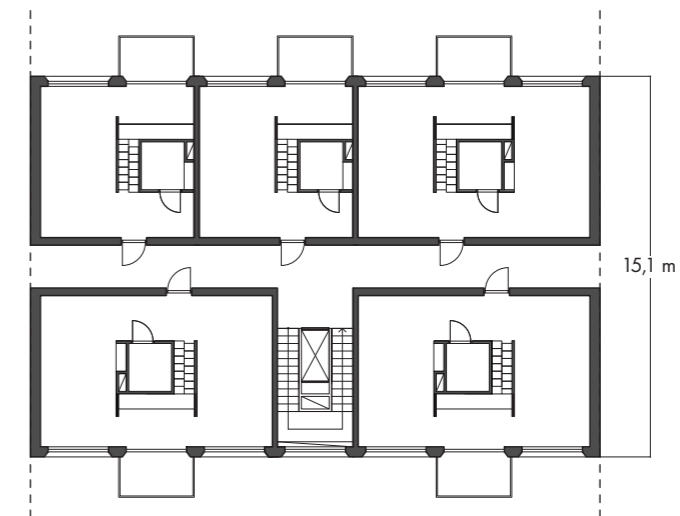

Figure 96. Possible configuration of apartments for lamella or tower block building.

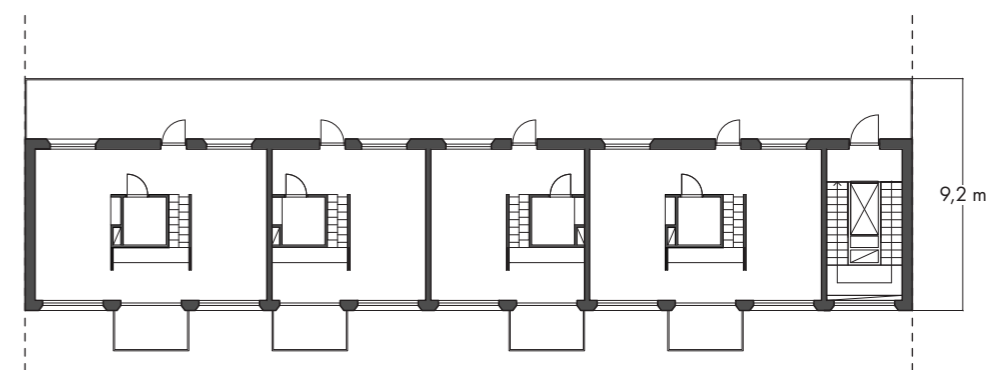

Figure 97. Possible configuration of apartments with access balcony.

1:300

## The two-room apartment

55 m<sup>2</sup> with or without loft

The storage functions in the module can be configured for different designations such as wardrobes, pull-out drawers, shelves, cabinets, space to hide technical equipment, independent of which room it is facing. Optional elements such as room divider with a sliding door can be added upon users need and preference. For the two-room apartment the one-sided kitchen facilitates circulation around the whole apartment, but

can be closed off with the optional sliding doors. In case of a loft, for both safety reasons, daylight access and high ceiling height in the kitchen, a catamaran-net at floor level of the loft is installed. The loft has sliding panels towards the kitchen in optional materials such as massive wood or paper that offer a diverse level of privacy, noise reduction and possibility to control daylight access. Storage and shelves are integrated in the interior module. Both apartments have balconies.



Figure 98. Illustration of the living room with built-in cabinet for TV, that easily can be closed and hidden.



Figure 99. Illustration of bedroom with a workspace and storage underneath the stairs of the Living Box.

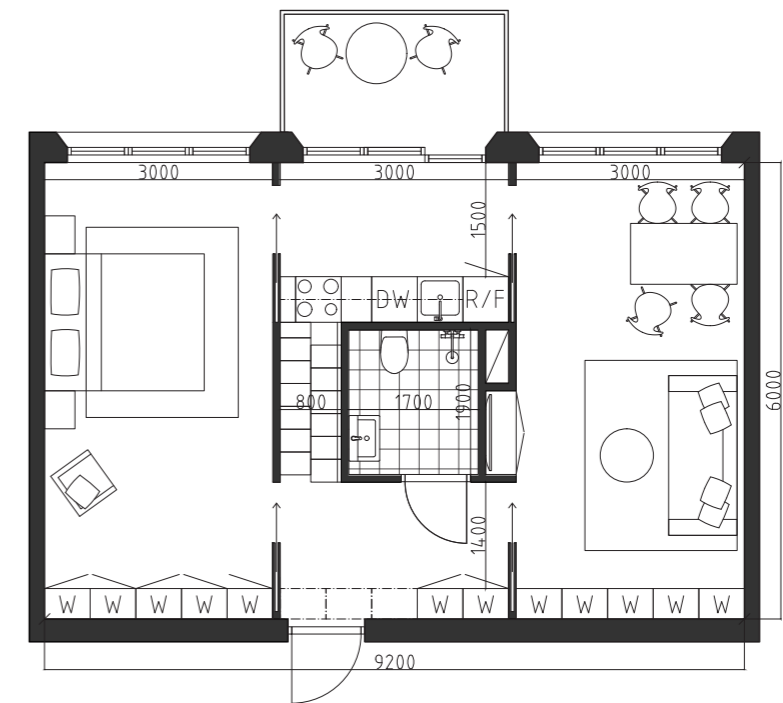

Figure 100. Floor 1 (Living Box I).

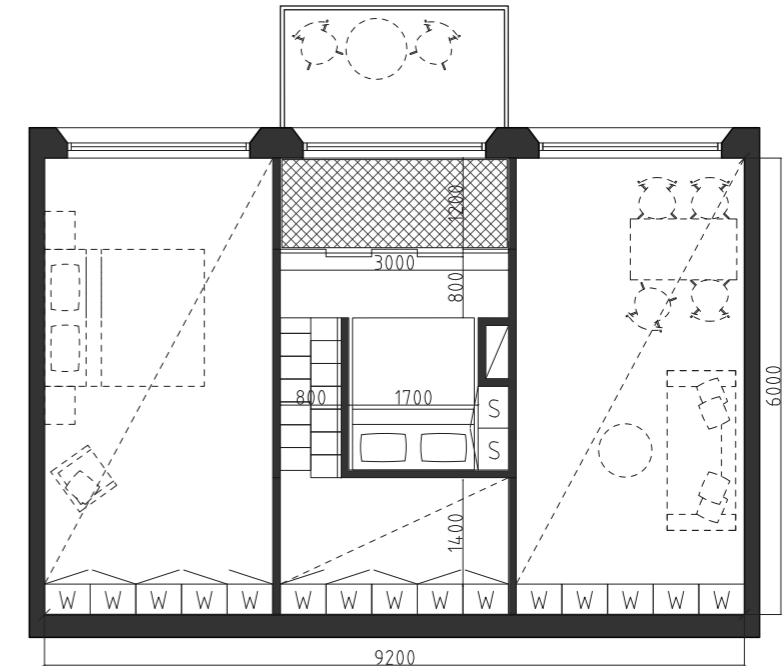

Figure 101. Floor 2 (Living Box I).

1:100

# Housing qualities analysis

The design fulfils the requirements for the gold-grading in the MAB analysis. If the apartment contains Living Box I (with a loft) or Living Box II (without loft) does not effect the grading of the apartment in the MAB analysis. If the apartment is one sided, with windows facing only one direction, the apartment fulfils 10/12 qualities.

However, if the apartment is accessed through an access balcony, that allows the apartment having windows in two directions, the apartment fulfils 11/12 qualities. The only quality that is not achieved in this design is the space efficiency, since the apartment is 5 m<sup>2</sup> larger than the size limit according to MAB.

## Two-room apartment with or without loft

Final grading of the MAB assessment:

Total grade	Aspect grade	Quality	
Gold	Functionality	1. Space efficiency	○
		2. Furnishable space	●
		3. Technical rationality	●
		4. Potential for home care	●
	Spaciousness	5. Axiality	●
		6. Circulation	●
		7. Room shape	●
		8. Flexibility	●
	Atmosphere	9. Multiple facade directions	○
		10. Balcony	●
		11. Daylight	●
		12. Dark space	●

Table 9. MAB result of analysis of floor plan.

## Two-room apartment with access balcony

Final grading of the MAB assessment:

Total grade	Aspect grade	Quality	
Gold	Functionality	1. Space efficiency	○
		2. Furnishable space	●
		3. Technical rationality	●
		4. Potential for home care	●
	Spaciousness	5. Axiality	●
		6. Circulation	●
		7. Room shape	●
		8. Flexibility	●
	Atmosphere	9. Multiple facade directions	●
		10. Balcony	●
		11. Daylight	●
		12. Dark space	●

Table 10. MAB result of analysis of floor plan.

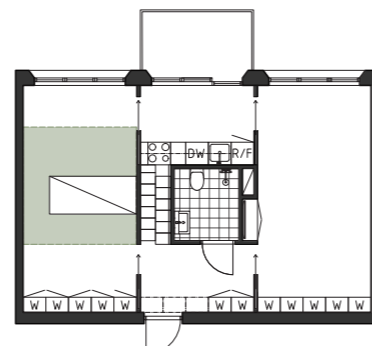

Figure 102. Functionality  
Eg: Bedroom capacity.

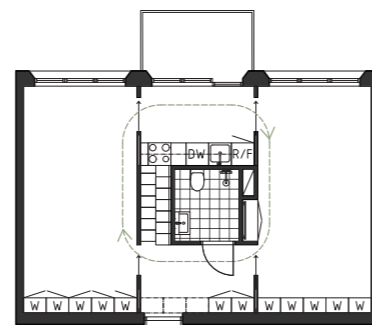

Figure 103. Spaciousness  
Eg: Circulation.

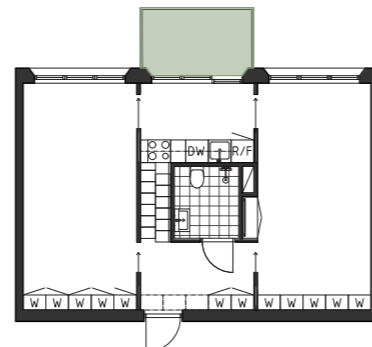

Figure 104. Atmosphere  
Eg: Balcony. 1:200

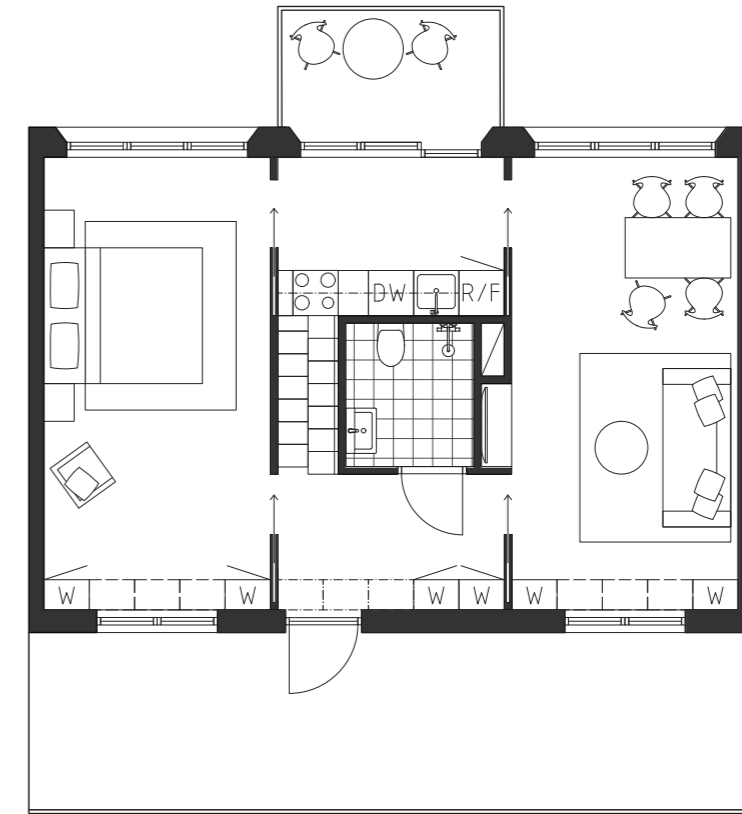

Figure 105. Floor 1 (Living Box I) with access balcony.

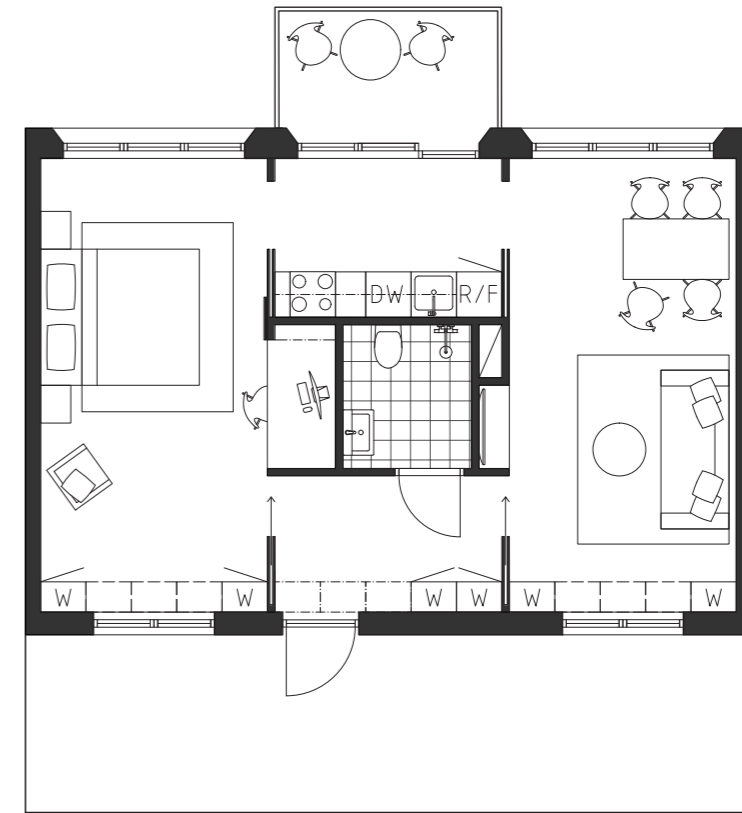

Figure 106. Floor 1 (Living Box II) with access balcony.

1:100



**Figure 107.** Illustration of the sightline seen from the bedroom, through the kitchen to the living room. The catamaran net, with access from the sleeping loft is visible in the ceiling of the kitchen.



**Figure 108.** Illustration from the interior of the sleeping loft, with sliding panels, that can be closed for privacy. Open panels allows direct sunlight and exterior views.



**Figure 109.** Illustration of the two-room apartment with Living Box I, and access balcony, that allows daylight from two directions. The window is integrated in the built-in storage in the exterior wall.



**Figure 110.** Illustration of the two-room apartment with Living Box II, containing an walk-in closet, that can be hidden behind a foldable door.



**Figure 111.** Illustration of the sightline through the kitchen towards the bedroom.



**Figure 112.** Illustration of the sightline from the living room, through the entrance, towards the bedroom.

## The one-room apartment

36 m<sup>2</sup> with or without loft

A one-room apartment of 36 m<sup>2</sup> is obtained by disconnecting one of the two identical rooms, and the interior module is consequently attached to an exterior apartment dividing wall. As a consequence, the storage cabinets next to the technical shaft are opened from the bathroom.

The apartment contains a large general room that can be furnished according to the tenants needs and likings. The sleeping loft creates a clear private zone in contrast to the large social space with high ceilings. The mirrored wall in the hallway creates an optical illusion of a more spacious apartment.



Figure 113. Illustration of the living room with closed cabinet-doors.



Figure 114. Illustration of the sightline from the kitchen to the main room, with the balcony to the left.

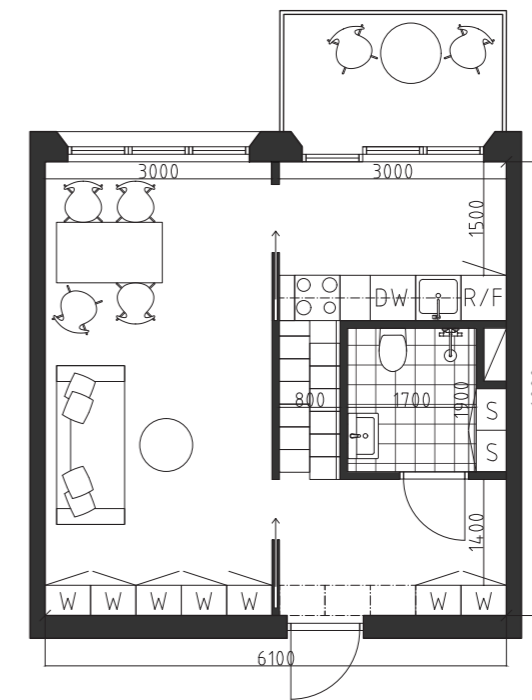

Figure 115. Floor 1 (Living Box I).

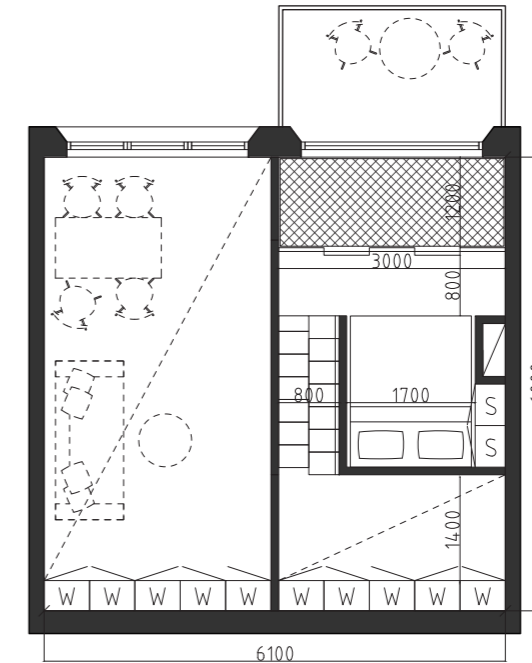

Figure 116. Floor 2 (Living Box I).

1:100

# Housing qualities analysis

The design of the one-room apartment fulfils the requirements for the silver grading in the MAB analysis. Compared to the two-room apartment, the one-room apartment does not fulfil qualities such as circulation, furnishable space and dark space. Axiality is only fulfilled in the apartment with loft. The one-sided apartment receives a silver score of each aspect. On the other hand, the access balcony apartment was awarded a gold grade for two out of the three aspects.

However all three aspects must achieve a gold score in order for the apartment to be awarded gold as the final grade. If the wardrobes in the main room is removed, the apartment fulfils the quality of furnishable space and is rewarded the gold grade in total. As a result, the wardrobes can be removed in order to achive a gold grade for the one-room apartments with loft and access balcony.

## One-room apartment without loft (Living Box II)

Final grading of the MAB assessment:

Total grade	Aspect grade	Quality	
Silver	Functionality	1. Space efficiency	○
		2. Furnishable space	○
		3. Technical rationality	●
		4. Potential for home care	●
	Spaciousness	5. Axiality	○
		6. Circulation	○
		7. Room shape	●
		8. Flexibility	●
	Atmosphere	9. Multiple facade directions	○
		10. Balcony	●
		11. Daylight	●
		12. Dark space	○

Table 11. MAB result of analysis of floor plan.

## Two-room apartment with access balcony and loft (Living Box I)

Final grading of the MAB assessment:

Total grade	Aspect grade	Quality	
Silver	Functionality	1. Space efficiency	○
		2. Furnishable space	○
		3. Technical rationality	●
		4. Potential for home care	●
	Spaciousness	5. Axiality	●
		6. Circulation	○
		7. Room shape	●
		8. Flexibility	●
	Atmosphere	9. Multiple facade directions	●
		10. Balcony	●
		11. Daylight	●
		12. Dark space	○

Table 12. MAB result of analysis of floor plan.

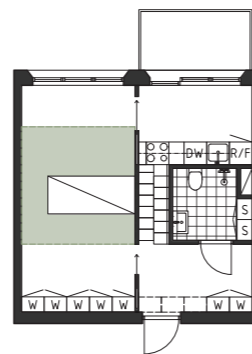

Figure 117. Functionality  
Eg: Bedroom capacity.

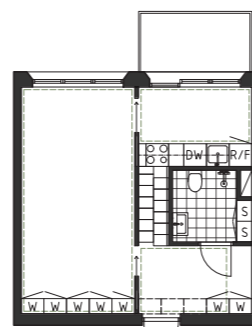

Figure 118. Spaciousness  
Eg: Room shape.

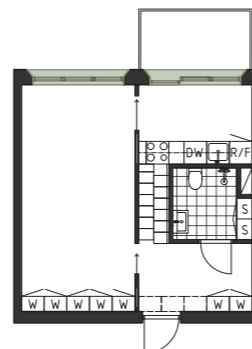

Figure 119. Atmosphere  
Eg: Daylight.

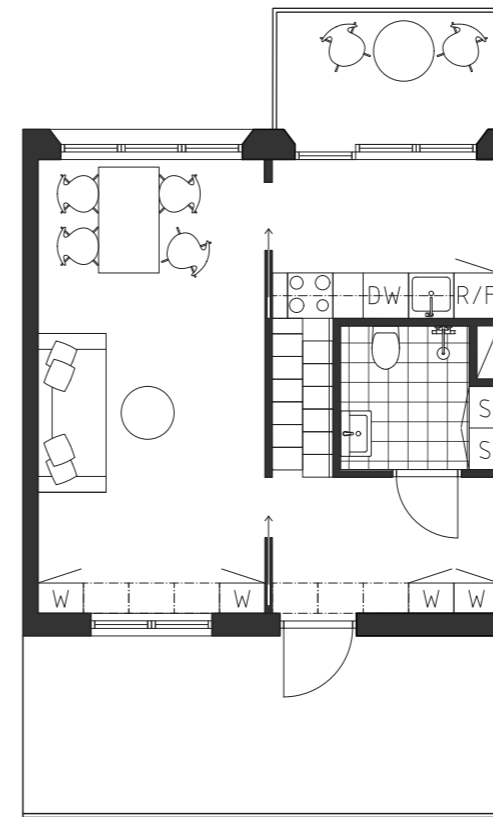

Figure 120. Floor 1 (Living Box I) with access balcony.

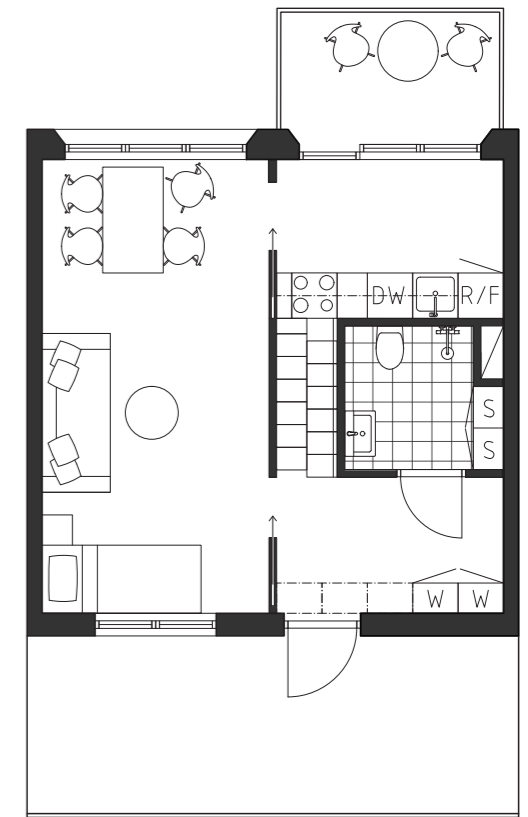

Figure 121. Floor 1 (Living Box I) without wardrobes.

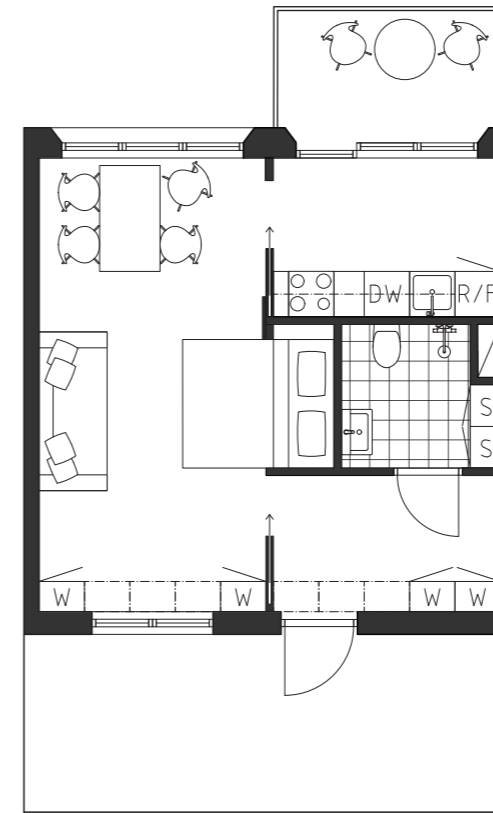

Figure 122. Floor 1 (Living Box II) with access balcony and integrated foldable bed.

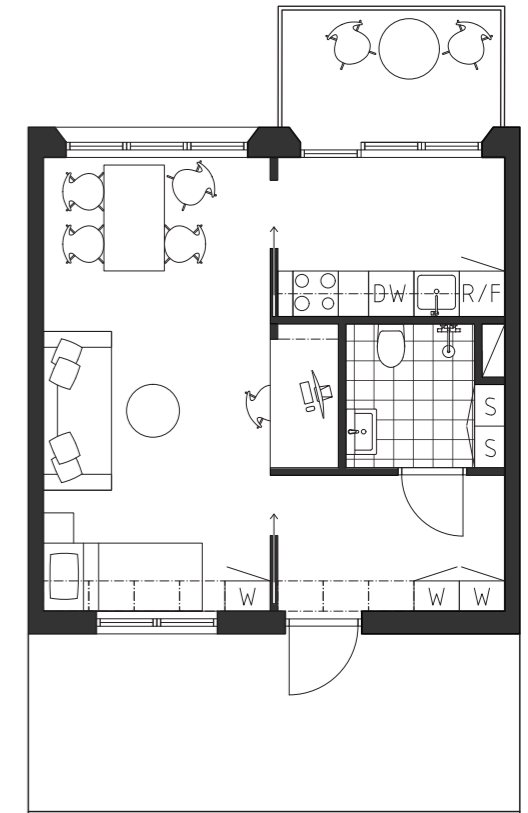

Figure 123. Floor 1 (Living Box II) with access balcony and integrated workspace.



**Figure 124.** Illustration of the sleeping loft, with sliding panels, seen from the catamaran net above the kitchen.



**Figure 125.** Illustration of the one-room apartment with Living Box I, with the integrated storage underneath the staircase.



**Figure 126.** Illustration of the one-room apartment with Living Box I, and access balcony, that allows daylight from two directions.



**Figure 127.** Illustration of the entrance, where the door and panels in mirror material, gives the illusion of a spacious hallway.



**Figure 128.** Illustration of main room, with a foldable bed, integrated in the Living Box. When the bed is folded and hidden, it gives more free space in the apartment during daytime.



**Figure 129.** Illustration of the one room apartment with closed cabinet doors, hiding the integrated objects.



**Figure 130-134.** The sequence of the variation of the different objects integrated in the Living Box.

## Analysis of design proposals

Both the two-room and one-room apartment resulted in high scores in the MAB analysis.

The one-sided one-room apartments without access balcony achieved a silver score. The one-room apartment with access balcony, sleeping loft and removed wardrobes achieved a gold score, while all versions of the two-room apartment achieved a gold score. This could imply that when designing small apartments, access to at least two facades with windows facing different directions is a quality of importance yet hard to achieve. Other qualities that were hard to fulfil in the one-room apartment was axuality and circulation, however axuality was possible to achieve in the apartment with a sleeping loft. Some qualities were on the other hand easy to fulfil in a free design proposal, such as adding a balcony, special windows features and gathering all installations in one technical shaft.

Because of the extent of built-in interiors in the designs, the quality of furnishability was hard to fulfil. This due to the fact that the required space of 800 mm in front of built-in interiors could not be included in the furnishable space. At least 50 % of the apartment's floor area must be free furnishable space according to the standards in MAB.

If the apartment would be designed with less built-in interiors, the quality of furnishability would be fulfilled. However, this raises the question; if most of the necessary furniture is built-in, less free space for furniture is needed. It could be discussed if the furnishable space could be less than 50 % in apartments with built-in interiors, since it requires less free standing furniture.

The only quality none of the apartments achieved, was the quality of space efficiency. This was however a conscious decision, since the theoretical framework suggested that too small apartments can lead to less flexibility and spaciousness, while having negative effects on the tenants health.

Instead the focus was to create flexible and general rooms with high accessibility. Since the minimum space for a bedroom with a double-bed is 3000 x 3700 mm according to Swedish standards, the general rooms were designed with this in mind. The design emphasises freedom and flexibility for users to decide the designation use of the rooms and the objects integrated in the interior module.

## Discussion

The design process and final design proposal of the interior module aimed to include and showcase a sustainable, long-lasting and functional alternative. The design is based on important theories about housing qualities that could be implemented in smaller apartments, both in existing and completely new apartments.

In contrast to the focus on small apartments, the final design proposals with integrated interior modules in new apartments, resulted in apartments larger in size than average (SCB, n.d.). It was never a target to design as small as possible, and the negative health issues connected to very small apartments emphasised by Urist (2013), conveyed a way to a more intermediate size. Nevertheless, the Swedish building standards including measurements for accessibility and furnishing in housing (Boverket, 2020) also played a major part for the module's configuration and dimension. The module's size is 3200 x 3000 mm with an accessible bathroom by 1700x1900 mm in the core, requiring a minimum 1300 mm free space to the wall for communication and a comfortable working area in the kitchen. For the lateral room or rooms, the largest measurements for fitting an accessible bedroom, 3000 x 3700 mm with free space for communication, define the dimensions of the space. With the minimum measurements of the module, it is possible to make a quick first assessment of the possible implementation in existing apartments and required space for new apartments.

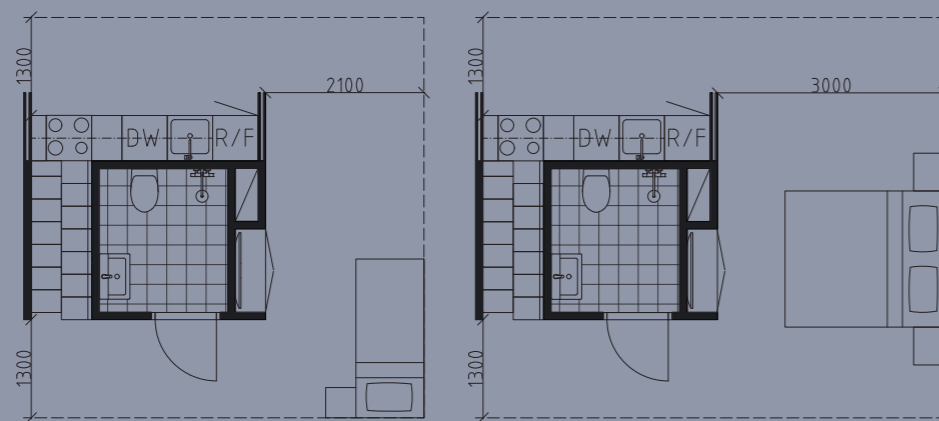

Figure 135, 136. Illustration showing the minimum measurement for the space around the Living Box, for a single- or double-bed.

Another important factor of the measurements of the interior modules was the cladding made of 600 mm wide plywood panels, resulting in the Living Box being 3000 mm, five plywood panels, wide. If the module would be a bit wider, it would have to follow these rules, resulting in being a minimum of 3600 mm wide, making the whole apartment 600 mm wider.

Consequently, the result was somewhat restraining, and it was hard to make small adjustments to the measurements of the Living Box. The result of the apartments might have been even better if the measurements could be altered. However, the fact that the interior modules only have a minimum height of 2400 mm or 3700 mm, allows the modules to be implemented in various apartment buildings, both new and old, with various ceiling heights, is an important quality.

In addition, advice on spatial solutions by Gronostajska and Szczegielniak (2021) were implemented in the design. This includes functional solutions such as designing with minimum floor area in the bathroom and general rooms that allows flexibility and living situations. Spatial solutions such as the use of the entire height of the wall, mezzanine with an extra space for a bed, using other instruments to divide space than walls, using space under the stairs or furniture and using a simple plan geometry with simple floor plans were also implemented in the final design.

The same author's (2021) argument about the difficulty to implement these functional elements in existing buildings, became evident during the first stages of design. But the interior module, including a loft, gives the opportunity to refurbish and transform industrial buildings with generous ceiling heights to residential buildings, which could be a sustainable alternative according to Höjer and Mjörnell (2018), who claims refurbishments is a more sustainable option in terms of reducing greenhouse gases (CO<sub>2</sub>) than building new. Other important solutions that were implemented into the interior module were optical solutions such as the mirror wall in the entrance, and the "window" between the sleeping loft and kitchen. Furniture solutions, such as the use of retractable or hideable furniture, built-in furniture, sliding doors or panels were also crucial for the final outcome of the design.

As predicted by Gronostajska and Szczegielniak (2021) the module can more easily be implemented in new projects. The final design of the module in new apartments resulted in the highest level, gold, in the MAB-evaluation of housing qualities of the apartment, which partly gave an indication of the accomplishment of answering the thesis research questions. The design proposal implemented in an apartment of 55 m<sup>2</sup> with two identical, but not pre-designated rooms, both meets MAB's requirements regarding flexibility and how Till & Schneider (2007) describe flexibility. Till & Schneider (2007) means the space is flexible when the user can decide themselves on how to use and occupy the space.

The attempt with a systematic and more academic based approach on the thesis design proposals by evaluating the housing qualities by using MAB, was satisfactory to some extent. As the MAB housing evaluation tool affirmed that the proposed floor plans created by the new designed interior modules have obtained equal to better scores than the original floor plans, important quality values were managed. It could have been close at hand to say the design was completely satisfactory just by scoring approved by the MAB tool, but the study demonstrates that in particular personal opinions and other aspects such as aesthetics, materiality and personal preferences are important to the final result. It is also important to highlight that comparison between the existing floor plans and suggested floor plans were not done from the same basics, as the apartments from the million homes programme were not fully accessible.

The choice to verify the quality of the interior modules by MAB resulted as a good complement, but personal knowledge, preferences and experience played a large role in assessing the final result. In particular, personal opinion is important when it comes to solutions that do not fit within the normative frame. The design of the interior module is quite simple and not configured with technical complicated solutions that need intricate handling procedures, in line with Urist (2013) theories about the negative health consequences of living small and needing to reconfigure the space throughout the day. This argument is strengthened by interpretations of the outcome of past innovative projects such as Experimental Housing (Till & Schneider, 2007) and Optibo (Boverket, 2004), where movable walls and other technical solutions were decommissioned or replaced with conventional solutions after some time.

A step towards reducing the unsustainable refurbishments, that can be caused by people's need to express their personal style and preferences (Femenias et al, 2016), and people's attitude towards architectural styles changes continually (Nordwall, 2012), is the proposed system for exchangeable and recyclable finishing panels in different colours and finishes. The importance of durable materials and easy renewal and replacement of worn-out material is highlighted by Norwall (2012), which is possible with a system that can be easily dismantled, sent to re-conditioning and returned to the user. Such a system with exchangeable parts based on re-use, re-cycle and reduce the material waste and use, contributes to the sustainable approach and the idea of a home that can last over time. On the other hand, a small apartment with a small interior module, limiting the possibilities of content of the interior module, also limits the possibility to stay in the same apartment in case of major changes in the user's constellations, for example when the number of habitants increases radically.

Wood was chosen as main material for both constructive and finishing layers as it fitted within the choice of a durable, sustainable material (Svenskt Trä, 2023) and wood bringing salutary properties and wellbeing (Häyrynen et al., 2020; Alapieti et al., 2020) to the home environment. The alternative with finishing boards made by recycled packaging may not have the same positive effects on human health as wood, but just by exposing the recycled packaging components in the board, could possibly encourage the users towards a more sustainable lifestyle.

# Conclusion

Both the presented theories and the different design proposals gave answers and advice on how sustainable and functional interior modules including integrated elements and objects can be designed to obtain good spatial qualities and important housing qualities in small apartments.

The possibility to design a variety of fully accessible, high-quality alternatives to already optimised small apartments with a large depth are limited, while the larger apartments with less depth with access to multiple directions and high ceilings, offer better conditions for future transformations and refurbishments. When it is necessary to upgrade basic functions to today's standards for accessibility in existing apartments, it puts the architect's skills to the test, as valuable floor area is lost within the pre-set and fixed apartment borderlines. The final design proposal, the interior module named the Living Box, replied to the three main questions of the thesis regarding a design that solves room sectioning, spatial configuration with a variation of functions that is adaptable, flexible, sustainable that lasts over time.

Firstly, when placing the Living Box within an apartment boundary, i.e. exterior walls of an apartment, different rooms and zones emerge. Different floor plan layouts with different numbers of rooms are achieved by particular placement of the interior module within the apartment boundary. The thesis presents two different placings, centric and along one apartment dividing wall. Ceiling height is another apartment boundary where the interior module acts as a room and spatial configuration element, as it clearly considers and divides the volume into different spaces.

Secondly, the Living Box, with integrated exchangeable elements and objects, exemplifies a range of different functions that can be fitted within the interior module. When smart solutions such as foldable beds, workspace and storage are integrated in the interior module, it facilitates free space and room for other additional functions to be placed in this space in the apartment instead. The interior module facilitates an adaptable apartment and is possible to change designation and use of space depending on tenants needs and changes in family constellations over time. Hence, the design can possibly better meet the future demands and consequential changes.

Thirdly, the use of sustainable, healthy, durable, and high-quality materials in combination with exchangeable interior objects and restorable panels in the interior module can strengthen the module's ability to last over time.

To sum up what has been presented and discussed, the design developed in this thesis is not the only solution for sustainable apartments with good housing qualities that lasts over time. But it is a quite simple, possible solution that meets the pre-set essential aims, that at the same time challenges the more conventional planned apartment layouts.

## Suggestion for further research

This thesis focused only on small apartments due to the thesis background and clear orientation towards sustainability. During the design phase, the extensive potential to obtain interesting floor plan configurations, good housing qualities by expanding both the interior module itself and the apartment area and volume, became both tempting and evident. Therefore, a continuation of developing the interior module for larger apartments would be beneficial. A wider range in size of interior modules that can be combined in residential buildings would be beneficial for diversity and user's different necessities.

Furthermore, developing the idea of making the modules in CLT as the load bearing structural element in a building, could be constructive for manufacturers of evolving prefabricated elements for residential buildings.

Additionally, a continuation of developing the module's components and materials to better understand and demonstrate the possibilities with production, implementation and costs would add value to the level of feasibility and decisive part for possible implementation in the future.

# Reflections

During the initial stage of the thesis, a lot of time was spent on both finding the design framework and designing solutions for transformations of existing apartments. When altering an already good floorplan, some housing qualities were gained, however some important qualities were lost.

Learnings from the explorative design phase were nevertheless useful for the final design solutions, but more time for more details and even further development of the final design proposal could have been beneficial. The use of MAB was useful as it can guide the architect to achieve better results regarding housing qualities of the design, but its criteria are more applicable to larger apartments. Some of the qualities in MAB seems to be difficult to almost impossible to fulfil in small apartments. As an example, the care for functional autonomy, so care and domestic care for a sick partner can take place at home without disturbing the other partner, is very hard to accomplish in a one room apartment.

In the aim of keeping a clear and simple concept for the Living Box and the apartments, some design solutions and qualities can possibly have been bypassed or missed out. It was a challenging balance between losing a clear concept for making exceptions and dispensation for gaining different results. A deviation in the generality of the room sizes and the centric placement of the interior module, could have resulted in apartments with different qualities and properties. The apartments could have been designed with a larger kitchen, making room for more cabinets, countertops, or a dining table, with the consequence of a smaller entrance with less storage possibilities. Smaller apartments have smaller possibilities to fulfil all desired features in the design, and every addition to the minimum standard measurements, unwantedly and very quickly, adds on square meters to the total floor plan area.

## Reference list

Alapieti, T., Mikkola, R., Pasanen, P., & Salonen, H. (2020). The influence of wooden interior materials on indoor environment: A Review. *European Journal of Wood and Wood Products*, 78(4), 617–634. <https://doi.org/10.1007/s00107-020-01532-x>

Alvin, Å. (2017, September 2). Drömlägenheten – här är den stora snackisen. *Norrköpings Tidningar*. Retrieved February 1, 2023, from <https://nt.se/nyheter/linkoping/dromlagenheten-har-ar-den-stora-snackisen-om4795533.aspx>

Astbury, J. (2022, February 11). Proctor and Shaw Designs London micro-apartment with "Sleeping cocoon". *Dezeen*. Retrieved February 1, 2023, from <https://www.dezeen.com/2021/09/25/shoji-apartment-proctor-and-shaw-london/>

Barbosa, J. A., Araújo, C., Mateus, R., & Bragança, L. (2015). Smart interior design of buildings and its relationship to land use. *Architectural Engineering and Design Management*, 12(2), 97–106. <https://doi.org/10.1080/17452007.2015.1120187>

Boverket. (2004). Optibo – Framtidens boende? - Ett debattinlägg om ett reurssnålt boende i framtiden (91-7147-827-2). Boverket.

Boverket. (2020). Standard för bostadsutformning. Retrieved April 24, 2023, from <https://www.boverket.se/sv/PBL-kunskapsbanken/regler-om-byggande/boverkets-byggregler/bostadsutformning/utformningsstandard/>

Braide, A. (2019, April 16). Dwelling in time: Studies on life course spatial adaptability. *Research Chalmers.se*. Retrieved May 19, 2023, from [https://research.chalmers.se/publication/509729/file/509729\\_Fulltext.pdf](https://research.chalmers.se/publication/509729/file/509729_Fulltext.pdf)

Christie, E. (2021, July 29). Green box apartment, Berlin by Ester Bruzkus Arkitekten. *Yellowtrace*. Retrieved February 1, 2023, from <https://www.yellowtrace.com.au/ester-bruzkus-arkitekten-green-box-apartment-berlin-bouchestrasse/>

Drömlägenheten - Dream Home. White Arkitekter. (2022, October 17). Retrieved February 1, 2023, from <https://whitearkitekter.com/project/dromlagenheten-dream-home/>

Environmental Action, EA. Retrieved April 7, 2023, from [https://www.e-a.earth/\\_files/ugd/425198\\_6f553fe5eb444350bb61b4acee3aef14.pdf](https://www.e-a.earth/_files/ugd/425198_6f553fe5eb444350bb61b4acee3aef14.pdf)

Femenías, P., Holmström, C., Jonsdotter, L. and Truvander, L. (2017) Arkitektur, materialflöden och klimatpåverkan i bostäder. [Electronic source]. Chalmers tekniska högskola.

Gromark, S., Andersson Björn and Nylander, O. (2021) "Criteria List of Housing Architecture Properties - A Way to Promote Residential Quality?"

Gronostajska, B., Szczegielniak, A. (2021) Inside a Micro-apartment: Design Solutions to Support Future Sustainable Lifestyles.

Hall, T. (ed.)(1999). *Rekordåren: En epok i Svenskt Bostadsbyggande*, 45-48. Boverket.

Hall, T., Vidén, S. (2015) The Million Homes Programme: A review of the great Swedish planning project, *Planning Perspectives*, 20(3), 301-328, <https://doi.org/10.1080/02665430500130233>

Hill, C. A. (2019). The environmental consequences concerning the use of timber in the built environment. *Frontiers in Built Environment*, 5. <https://doi.org/10.3389/fbuil.2019.00129>

Holmen. (2023). Progress through nature and Technology. Progress through nature and technology. Retrieved April 7, 2023, from <https://www.holmen.com/>

Häyrinen, L., Toppinen, A., & Toivonen, R. (2020). Finnish young adults' perceptions of the health, well-being and sustainability of wooden interior materials. *Scandinavian Journal of Forest Research*, 35(7), 394–402. <https://doi.org/10.1080/02827581.2020.1813798>

Höjer, M., & Mjörnell, K. (2018). Measures and steps for more efficient use of buildings. *Sustainability*, 10(6), 1949. <https://doi.org/10.3390/su10061949>

Luco, A. (2020, February 25). The schoolhouse / Rome office. *ArchDaily*. Retrieved February 1, 2023, from <https://www.archdaily.com/934261/the-schoolhouse-rome-office>

Nordwall, U. (2012) Architectural qualities in housing. Licentiate thesis (summary) Umeå: University of Umeå, 2012. Umeå

Nylander, O., Femenias, P., Andersson, M., Morichetto, H., & Braide, A. (2018, June 15). Bostadsforskare Om Bostadskvalitet. Retrieved February 25, 2023, from <https://research.chalmers.se/en/publication/503607>

Nylander, O.( 2018). *Svensk Bostadsarkitektur : Utveckling från 1800-tal till 2000-tal*. Studentlitteratur AB..

Nägeli, W., Tajeri, N & O'Donovan, J. R. (2016), Small interventions: New ways of living in post-war modernism. Birkhäuser, part of Walther de Gruyter GmbH. 54-60.

Ottosson Färgmakeri. (2022). Miljö & Energi. Retrieved April 7, 2023, from <https://ottossonfarg.com/om-ottosson/miljo/>

Paruta, P., Boucher, J., & Pucino, M. (2022). (rep.). Plastic Paints. The Environment. A global assessment of paint's contribution to plastic leakage to Land Ocean & Waterways.

Recoma. (2022). Our products. Retrieved April 7, 2023, from <https://www.recoma.com/product/design-board>

Rojas, C. (2017, July 5). Snabba Hus Västberga / Andreas Martin-Löf Arkitekter. *ArchDaily*. Retrieved February 1, 2023, from <https://www.archdaily.com/875086/snabba-hus-vastberga-andreas-martin-lof-arkitekter>

SCB Statistiska centralbyrån (SCB) (n.d.). Bostadsarea Rikets Storstäder 1999-2020. [Unpublished source].

SCB Statistiska centralbyrån (SCB) (2022). Nästan 5,1 miljoner bostäder i landet. Retrieved January 27, 2023, from <https://www.scb.se/hitta-statistik/statistik-efter-amne/boende-byggande-och-bebyggelse/bostadsbyggande-och-ombyggnad/bostadsbestand/pong/statistiknyhet/bostadsbestandet-31-december-2021/>

Schneider, T. and Till, J. (2007) *Flexible housing*. Oxford: Architectural Press.

Stenberg, E., (n.d.). Flexibelt miljöprogram kan möta nya bostadsbehov. DIVA, Digitala Vetenskapliga Arkivet. <https://www.diva-portal.org/smash/get/diva2:578999/fulltext01.pdf>

Svenskt Trä. (2023). TräGuiden. Digital handbok för trä och träbyggnad. Retrieved April 7, 2023, from <https://www.traguiden.se/>

Svenskt Trä (n.d.). Framtiden växer på träd. Retrieved April, 7, 2012, from <https://www.svensktra.se/bygg-med-tra/byggande/framtiden-vaxer-pa-trad/>

Tervo, A., & Hirvonen, J. (2020). Solo dwellers and domestic spatial needs in the Helsinki Metropolitan Area, Finland. *Housing Studies*, 35(7), 1194-1213. <https://doi.org/10.1080/02673037.2019.1652251>

United Nations. (n.d.-a). Climate change - United Nations sustainable development. United Nations. Retrieved April 7, 2023, from <https://www.un.org/sustainabledevelopment/climate-change/>

United Nations. (n.d.-b). Life on Land: Why it matters. Retrieved April 7, 2023, from [https://www.un.org/sustainabledevelopment/wp-content/uploads/2019/07/15\\_Why-It-Matters-2020.pdf](https://www.un.org/sustainabledevelopment/wp-content/uploads/2019/07/15_Why-It-Matters-2020.pdf)

United Nations. (n.d.-c). Responsible consumption & production: Why it matters. United Nations. Retrieved April 7, 2023, from [https://www.un.org/sustainabledevelopment/wp-content/uploads/2019/07/12\\_Why-It-Matters-2020.pdf](https://www.un.org/sustainabledevelopment/wp-content/uploads/2019/07/12_Why-It-Matters-2020.pdf)

United Nations. (n.d.-d). Sustainable cities: People why they matter. United Nations. Retrieved April 7, 2023, from [https://www.un.org/sustainabledevelopment/wp-content/uploads/2019/07/11\\_Why-It-Matters-2020.pdf](https://www.un.org/sustainabledevelopment/wp-content/uploads/2019/07/11_Why-It-Matters-2020.pdf)

United Nations. (n.d.-e). Sustainable development economic and social council. United Nations. Retrieved April 7, 2023, from <https://www.un.org/ecosoc/en/sustainable-development>

United Nations. (n.d.-f). Take action for the sustainable development goals - united nations sustainable development. United Nations. Retrieved April 7, 2023, from <https://www.un.org/sustainabledevelopment/sustainable-development-goals/>

Urist, J. (2013, December 19). The Health Risks of Small Apartments. *The Atlantic*. Retrieved February 1, 2023, from <https://www.theatlantic.com/health/archive/2013/12/the-health-risks-of-small-apartments/282150/>.

Ösönerplast. (2022). Plexiglas - Det mångsidiga materialet. Ösönerplast. Retrieved April 7, 2023, from <https://www.osonerplast.se/plexiglas>

## Figure list

The figure list includes photos and illustrations retrieved from public resources. Other illustrations, photos, drawings, tables and renderings are made by the authors of this thesis, and therefore not listed in this section.

**Figure 1:** Sustainable Development Goals, United Nations. Retrieved May 7, 2023 from (<https://sdgs.un.org/goals>)

**Figure 2:** Petersens, Lennart af, (1971). Stockholms stadsmuseum, ref. nr: SSMF095666. Stockholmskällan. Retrieved May 7, 2023 from (<https://stockholmskallan.stockholm.se/post/4945>)

**Figure 3:** Leandersson, Bert, (2018). White Arkitekter. Retrieved May 7, 2023 from (<https://whitearkitekter.com/se/projekt/frostaliden/>)

**Figure 15:** In the public domain (n.d.). Wikimedia commons. Retrieved May 7, 2023 from (<https://commons.wikimedia.org/wiki/File:Experimenthusen-i-J%C3%A4mbrott-3.jpg#file>)

**Figure 16:** Reuter Metelius, Anna (n.d). Göteborgs Stadsmuseum, ref. no: 170012:210. Retrieved May 7, 2023 from ([https://samlingar.goteborgsstadsmuseum.se/carlotta/web/image/zoom/1152922/D%C3%A4ckshuset%20-%20Kalleb%C3%A4ck%2013:3\\_11.jpg;jsessionid=175YuW011BpFZpB5wxSUt3TtM0cF4F2KpK1qP6jc.s002iw39](https://samlingar.goteborgsstadsmuseum.se/carlotta/web/image/zoom/1152922/D%C3%A4ckshuset%20-%20Kalleb%C3%A4ck%2013:3_11.jpg;jsessionid=175YuW011BpFZpB5wxSUt3TtM0cF4F2KpK1qP6jc.s002iw39))

**Figure 17:** Leandersson, Bert (2018). Boverket. Retrieved May 7, 2023 from ([https://www.boverket.se/globalassets/publikationer/dokument/2004/optibo\\_framtidens\\_boende.pdf](https://www.boverket.se/globalassets/publikationer/dokument/2004/optibo_framtidens_boende.pdf))

**Figure 18:** White Arkitekter, photographer unknown (n.d.). White Arkitekter. Retrieved May 7, 2023 from (<https://fastighetstidningen.se/vi-tittar-in-i-vallastaden/>)

**Figure 20:** Rieger, Robert (n.d.). Ester Bruzkus Arkitekten. Retrieved May 7, 2023 from (<https://www.esterbruzkus.com/en/projects/the-green-box>)

**Figure 21:** Rieger, Robert (n.d.). Ester Bruzkus Arkitekten. Retrieved May 7, 2023 from (<https://www.esterbruzkus.com/en/projects/the-green-box>)

**Figure 23:** Alexander, Neil (2019). ArchDaily. Retrieved May 7, 2023 from (<https://www.archdaily.com/934261/the-schoolhouse-rome-office>)

**Figure 24:** Alexander, Neil (2019). ArchDaily. Retrieved May 7, 2023 from (<https://www.archdaily.com/934261/the-schoolhouse-rome-office>)

**Figure 26:** Fowelin, Johan (2016). Andreas Martin Löf Arkitekter. Retrieved May 7, 2023 from (<https://martinlof.se/projects/vastberga/>)

**Figure 27:** Fowelin, Johan (2016). Andreas Martin Löf Arkitekter. Retrieved May 7, 2023 from (<https://martinlof.se/projects/vastberga/>)

**Figure 29:** Eriksen, Ståle (n.d.). Dezeen. Retrieved May 7, 2023 from (<https://www.dezeen.com/2021/09/25/shoji-apartment-proctor-and-shaw-london/>)

**Figure 30:** Eriksen, Ståle (n.d.). Dezeen. Retrieved May 7, 2023 from (<https://www.dezeen.com/2021/09/25/shoji-apartment-proctor-and-shaw-london/>)





**CHALMERS**  
UNIVERSITY OF TECHNOLOGY