



Thank you

*Peter Christensson*

For the guidance, encouragement and unwavering support throughout this journey. Your help has been truly invaluable.

*Naima Callenberg*

For your insightful feedback and the valuable references that helped deepen this work.

*To my fellow students*

For your perspectives, motivation and shared joy. Your presence made this process not only easier but also much more rewarding.

*To my family*

For always believing in me.

## **Echoes of the past**

Exploring collective memory in public space through scenographic methods

*Cecilia Lindersson*  
2025

*Chalmers School of Architecture*  
*Department of Architecture & Civil Engineering*  
*Architecture and Urban Design, MPARC*  
*Architectural Experimentation*  
*Examiner: Naima Callenberg*  
*Supervisor: Peter Christensson*



**CHALMERS**



## Abstract

This thesis explores how scenography can serve as a spatial strategy to activate, engage and represent collective memory in public spaces. By examining the interplay between design and narrative, the research aims to uncover methods for creating immersive, participatory elements that reveal historical narratives, foster collective dialogue and create connections between people and place.

Grounded in Marice Halwachs' theories of collective memory and drawing from practices in scenography and urban design, the thesis investigates the potential of temporary architectural interventions to trigger memory recall and reinterpret historical layers. These ideas are tested through a spatial proposal at Näckrosdammen in Gothenburg - one of the few remaining sites from the 1923 Jubilee Exhibition - where three poems by Karin Boye form the dramaturgical structure of the installation.

The design process has been informed by scenographic methods such as rhythm mapping, material dramaturgy and emotional composition. A dual reading - from both an architectural and scenographic perspective - has shaped the investigation. While the architect's voice has focused on constructional clarity, permanence and technical feasibility, the scenographer has explored presence, atmosphere and embodied experience.

The result is a site-specific installation that stages memory through spatial rhythm, contrasts and material narratives. Elements such as floating granite slabs, submerged oak and reflexive textiles are composed to evoke past and present simultaneously. The work illustrates how temporary design can become a performative medium for storytelling, enabling emotional resonance and layered interpretation. By bridging scenography and architecture, the thesis contributes to current discourse on public memory and ephemeral placemaking, offering an alternative methodology for how design can both reflect and rewrite our shared cultural landscapes.

*Keywords: collective memory, scenography, public space, ephemeral placemaking*

# Cecilia Lindersson

|  |                    |
|--|--------------------|
| BA in Architecture<br><i>Chalmers University of Technology</i>                   | 2020-2023          |
| MSc in Architecture and Urban Design<br><i>Chalmers University of Technology</i> | 2023-2025          |
| <i>Erasmus+ ENSA Paris-La Villette</i>   | <i>autumn 2024</i> |

## **Studios**

|                            |           |
|----------------------------|-----------|
| Housing inventions 1       | 2023-2024 |
| Social-Ecological Urbanism | 2024      |

# Echoes of the Past

## Dramatis Personae

|                                 |    |                               |
|---------------------------------|----|-------------------------------|
| <b>The first line</b> .....     | 7  | The introduction to the story |
| <i>Background</i>               | 8  | Setting the scene             |
| <i>The Framework of the act</i> | 11 | The structure of the stage    |
| <b>Prolog</b> .....             | 12 | The opening act               |
| <i>Collective memory</i>        | 14 | The past on stage             |
| <i>Scenography</i>              | 17 | Designing the performance     |
| <b>The performance</b> .....    | 28 | The act unfolds               |
| <i>The stage</i>                | 32 | The space of the story        |
| <i>The manuscript</i>           | 48 | The script of the stage       |
| <i>ACT I</i>                    | 50 | The beginning of the drama    |
| <i>ACT II</i>                   | 52 | The climax                    |
| <i>ACT III</i>                  | 54 | The resolution                |
| <i>The translation</i>          | 56 | From theory to reality        |
| <i>The model</i>                | 66 | The blueprint of ideas        |
| <b>Epilogue</b> .....           | 74 | The final curtain             |
| <b>Bibliography</b> .....       | 80 | Sources of inspiration        |

The first



st line

Picture 1. View from Fyrtornet, Gothenburg 1923

## Background

We all can relate to memory - it defines our history, identity, and societal role. Without memory, we lose the core of who we are. Architecturally, memory has always been ingrained in the built environment. Buildings, monuments, and public spaces serve as physical manifestations of history to help people recall and connect with their past (Forty, 2000). The discussions today around our societal memory and our architectural memory are ongoing; almost every day, we find articles in the newspaper or magazines that touch on the subject, discussing a new area that is under development, a building that risks being demolished, or a piece of cultural heritage that risks being forgotten. From 2018 (Göteborg Stad), Gothenburg has approved an architecture policy aimed at ensuring the city's identity and working as a "brave role model within architecture", emphasizing the importance of preserving historic buildings and environments in the city planning to maintain the collective memory and the unique character of the city. Despite this, Gothenburg still faces a lot of criticism and has opened up for multiple discussions regarding how the city manages its historical heritage and which memories are chosen to be preserved or lost in the development. A recent example of this was the demolishing of Flickläroverket in 2023 (Föreningen FAS-AD, 2023), a building with a significant historical and cultural meaning for Gothenburg,

or the demolishing of the iconic Shellmacken in Majorna in December 2024 (Sveriges Radio, 2024). The discussions mainly focus on the buildings or place itself. However, street art and grassroots movements have demonstrated the power of public space to express collective memory. These expressions often reflect marginalized voices, aiming to reclaim spaces to tell untold stories. In Bergsjön in 2019, the artist Rob McDonald worked to create a collective memory monument over the worker's housing struggle and organization in Gothenburg's million program (Göteborgs Konsthall, 2019). This project aimed to highlight and keep the memories and experiences often marginalized in the official history description.

Scenography also offers alternative tools and methods for representing history, engaging and inviting audiences, and rethinking the role of spatial design in activating memory. Through temporary installations and spatial interventions, scenography can create a more dynamic and collective understanding of history. Unlike traditional architecture, which often manifests memory through permanent structures, scenography can work as a living and changeable form of memory production. Just as temporary installations and site-specific performances have been used to highlight forgotten stories or invisible layers in the city, scenography can work as a method to question and enhance the collective memory in the built environment.

In light of these discussions, this thesis explores how scenographic methods can be used as tools for activating collective memory within the urban landscape - not by preserving the past in a static sense, but by opening up poetic and reflective spaces that invite individuals to engage with layers of memory through presence, materiality and time. The chosen site - Näckrosdammen in Gothenburg - is rich with both physical and



immaterial traces. Originally created for the city's 1923 Jubilee Exhibition (Humlesjö, Siska, Åhlfeldt, Johan, Strinnholm, Anders et al. 2023) and later transformed into a tranquil park-like setting, the place carries a subtle yet layered memory of cultural aspirations, transformation and everyday use. Through the lens of scenography, this project seeks to explore how such underlying histories and emotions can be made visible, experienced and reimagined. By connecting the place's historical significance with the poetic world

of Swedish poet Karin Boye, this intervention proposes a layered narrative in which different stories illuminate and strengthen one another. The memory of Karin Boye - her voice, her words, her presence in the city - can amplify the memory of Näckrosdammen, and likewise, the specific qualities and history of the site can give new resonance to her poetry. In this way, memory becomes a dialogue - a scenographic interplay between text, place and body.

**Research questions**

*In what ways can scenography reframe public space as a dramatical landscape of memory and transition?*

*How can scenographic thinking translate poetry into spatial rhythm and material composition in temporary architectural interventions?*

*The first line* of public space. Scenography includes multiple sensory elements, including both visual and auditory components. However, in this exploration the focus will be on the visual aspects, such as light, materials and the spatial configuration of the design. Sound design and auditory elements will not be included in the analysis.

## **Intentions**

The aim of this thesis is to rethink and understand the importance of narrative and storytelling in public space, and to explore how scenographic methods can be used to activate these dimensions. In particular, the thesis investigates how practices from theatrical scenography can inform spatial design processes by applying them to a specific public site in Gothenburg. As a result, the design proposal will serve as a practical investigation of the research question: “How can scenographic methods inform temporary architectural interventions that engage with collective memory?”

In this research the expression temporary architecture is used interchangeably with temporary installations and refer to their ability to create a dynamic interplay with space and collective histories. Temporary interventions can invite surrounding communities to experience history and identity in a momentary thus far deep manner. The very nature of temporary works to emphasize the transient, fluid character of memory, and encourages reflection on the stories that shape our understanding of space, people and culture.

## **The framework of the act**

Collective memory is a subject with multiple interpretations. In this thesis, the concept will be explored especially through the work of Maurice Halbwachs, who introduced and developed the term. His term will serve as the primary theoretical foundation for understanding how memory is shaped within social contexts.

Scenography is a multidisciplinary field that intersects and is used within different areas such as film, architecture and exhibition design. However, this research will focus solely on scenographic methods within theatre, investigating how they can be applied to spatial storytelling and the transformation

# Prologu

ue

## Collective Memory

In the book *On Collective Memory* (1992), philosopher Maurice Halbwachs states that memory is not an individual, private happening but is most likely shaped by the social context in which we exist. Halbwachs means that memories are always embedded into a collective structure, where social groups and institutions - such as family, education, and culture - play a significant role in how we remember. He states that collective memory is not only the sum of individual recollections, but rather an active process in which certain events are emphasized while others are downplayed or forgotten. This selection process takes place through communal narratives, rituals, and symbols that reinforce a shared identity. Memories are chosen and shaped by the needs and values within a particular social context, creating a feeling of belonging and continuity. Halbwachs means that the collective nature of memory is central to how historical narratives are constructed, and communities are defined. Our memories are continuously reshaped and interpreted through our social relations and institutions.

### **Rethinking the representation of memory**

Memory can be viewed as an active construction; the work of Lisa Salzman (2006) explains how artists use different strategies to construct memory in their work, which means that memory is never a passive recollection of the past but an active process

*Collective memory* of selection and interpretation. One often finds a strain between memory and forgetting; in contemporary art, artists must navigate between keeping and erasing parts of history, affecting both the individual and the collective identity. In her work, Salzman also emphasizes that one must understand the importance of integrating perspectives from memory studies, culture studies, and art critiques to understand the relationship between art, memory, and identity. She means this opens up a broader analysis of how artwork can work as a tool to process and reshape the past.

Contemporary art mirrors history and plays an active role in creating and shaping the narratives that structure the collective memory. One clear example discussed by Salzman is the work of artist Christian Boltanski. In her book *Making memory matter - Strategies of Remembrance in Contemporary Art*, she examines how Boltanski creates installations using found objects, archival photographs, and personal belongings to evoke and construct collective memory. His work transforms individual memory traces - such as forgotten objects and personal images - into a public narrative of loss and remembrance. By doing so, Boltanski challenges traditional memorial forms and invites viewers to engage with memory as a living, dynamic process that bridges the personal with the communal. This example illustrates how artists can rework private histories into shared cultural experiences, thereby actively shaping how collective memory is experienced and understood.



*Picture 2. MONUMENTA 2010 by Christian Boltanski*

The monumental installation was created as a strong physical and psychological experience. Through visual and auditorial intensity the artwork brings up questions about nature, humanity, memory and the fleetingness of life.

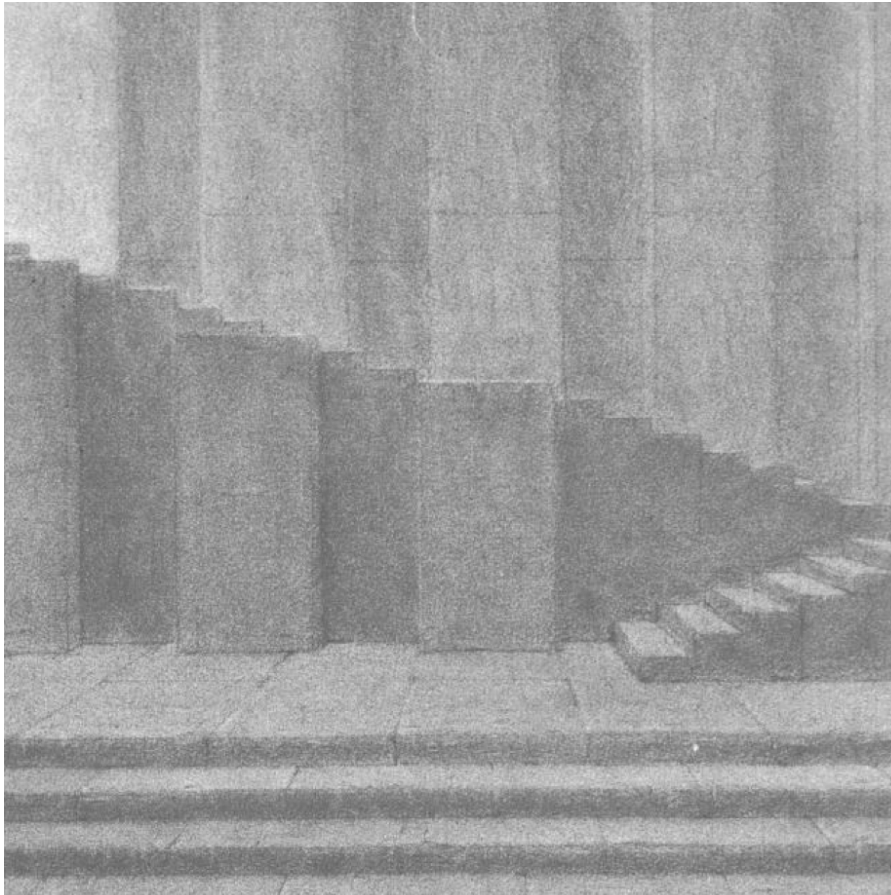

*Picture 3. Stage set design by Adolphe Appia*

The stripped-down design creates an understanding of the movement of the room and the use of light invites curiosity about what will happen or is happening behind the scenes.

## Scenography

### Scenography as a narrative force

Scenography plays a significant role in storytelling; it is more than just the visual components. To create meaningful scenography, one must understand the role of dramaturgy and how all the theatrical elements interact. Aristotle's *Poetics* (c. 335 BCE), one of the earliest influential works on dramaturgy, categorizes the six key components of tragedy, including *opsis*—the visual elements of theatre, such as staging and scenography.

Dramaturgy has shaped theatre, and scenography has evolved alongside it (Cattaneo, 2021). In *The Art of Dramaturgy* (2021), Anne Cattaneo explores the role of the dramaturg, tracing its roots back to 18th-century Germany, where Gotthold Ephraim Lessing pioneered the dramaturg as a critical thinker rather than just a playwright. Dramaturgy has evolved beyond textual analysis to include interdisciplinary approaches, incorporating multimedia, performance art, and spatial sto-

rytelling. This shift reflects the broader transformation in theatre, where scenography plays an increasingly active role in shaping narrative and audience experience.

### The evolution of scenography

Pamela Howard, in *What is Scenography?* (2018) charts the historical progression of scenography, illustrating how it has transitioned from only a static background decoration to an integral, interactive storytelling device.

**Ancient Greece and Rome:** During this time, scenography mainly consisted of architectural elements such as *skene* and *periaktoi* (background building and rotating painted panels), which created a functional, however limited, stage environment

**Renaissance and Baroque periods:** The introduction of perspective painting led to more illusionist scenography, transforming stages into seemingly endless landscapes.

**Realism and Naturalism:** The 19th-century's scenography focused more on mimicking real-life environments, often including detailed interior designs that supported psychological realism in theatre.

One major turning point came with Adolphe Appia in the early 20th century (Pitches, 2012). He moved away from literary realism in favor of abstraction, focusing on light, form, and movement. His influence reshaped modern scenography, leading to contemporary practices where digital projections, site-specific performances, and interdisciplinary collaboration redefine how space and narrative interact.

### Scenography as a process

Pamela Howard (2018) emphasizes that scenography is not just about aesthetics but a living process that should be involved from the conceptual stage of a production. She argues that scenographers are storytellers in space, shaping the setting and emotional and thematic layers of a performance. Lars-Åke Thessman builds on this perspective in *Till rum blir tiden här* (2018), describing scenography as an immersive experience that engages the audience. His work explores how scenography shapes time and space, making the audience passive observers and active participants in the theatrical experience. He suggests that scenographers must balance the subtle and the explicit, allowing space for interpretation while guiding the audience's emotional journey.

### Scenography beyond theatre

Expanding on this notion, Sodja Lotker and Richard Gough, in *On Scenography: Editorial* (2013), argue that scenography extends beyond the theatre and cinema into everyday life. Every space we move through - public or private - carries a narrative, shaping how we experience and interact with our surroundings. They suggest that scenography is not merely a backdrop but a dynamic system within which stories unfold. A quote from the book *Till rum blir tiden här* (2018, authors translation) resonates well with this thought:

“We draw in the sand, but the art of the moment deserves its history, well worth telling.”

This reminds us that scenography is not something we observe but something we live in.

#### Figure 1. How is the story told?

Illustration over how a story can be told by rethinking the traditional ways of storytelling and making the audience a part of the play. This affects how the play is experienced. The storytellers are the yellow figures and the audience are the red ones.

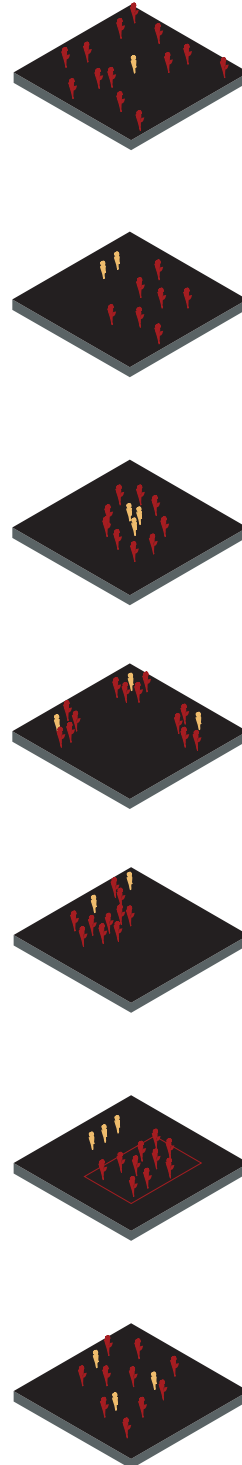

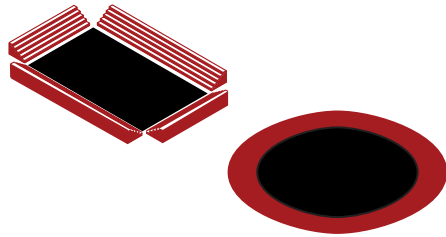

Black box/ In the round

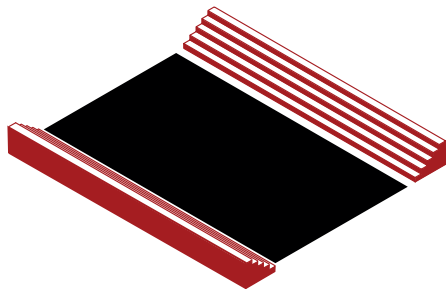

Traverse

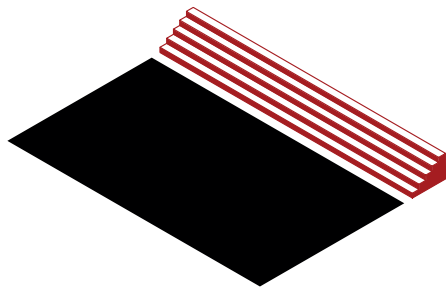

End-on (&amp; proscenium stage)

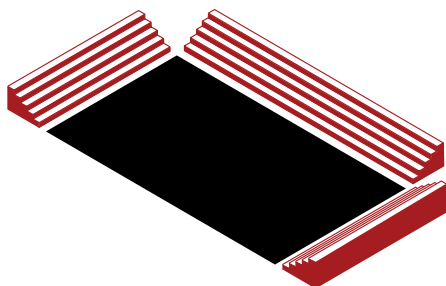

Thrust stage

**Figure 2. Stagetypes**

Thrust, end-on/proscenium, traverse, and black box/in-the-round stages offer different spatial dynamics between actors and audience. Thrust stages extend into the audience, creating intimacy; end-on/proscenium stages maintain a frontal view and clear separation. Traverse stages offer dual perspectives, black box and in-the-round setups allow flexible audience arrangements and scenographic freedom.

### A scenographic thesaurus

Within scenography, language plays a crucial role in defining space, movement, and the relationship between performers and audience. It provides a framework for describing not only the physical elements of a stage but also the dynamic interactions that shape a performance. This specialized vocabulary is useful not only within theatre but can also be applied to architecture and urban planning. If we interpret public spaces as theatrical stages, language becomes a tool for analysing how people move through and experience these environments. Some terms, such as entrance and exit, already exist in architectural discourse. Still, scenography offers a richer vocabulary that can deepen our understanding of spatial composition, rhythm, and dramaturgy in everyday environments. Concepts like blocking position, scene transition, and tableau can help us articulate how public and private spaces shape movement, focus, and atmosphere. By borrowing scenographic language, architects and urban designers can create spaces that function and tell a story, guiding movement and engagement more intentionally.

The selections of words are here based on their relevance to this project. The scenography field contains many more, but these are the ones that I saw as the most useful in my work. The descriptions of the words are taken from the union Scen & Film (2025) and translated into a more extensive architectural description in the section *Movement and spatial dramaturgy*.

|                     |  |
|---------------------|--|
| Set design          | <i>Collective term for the visual elements of the stage, such as scenery, furniture and props.</i>         |
| Backdrop            | <i>Background elements that frame a stage or a space.</i>  |
| Scenic composition  | <i>The visual composition of the set at a given point in the performance.</i>                              |
| Decor               | <i>Elements on stage contributing to the scenography.</i>  |
| Coupe de visibilité | <i>A section which shows what you see from the "worst" seat in the theatre.</i>                            |
| Entrance/Exit       | <i>How a person moves in and out of a space.</i>   |
| Scene transition    | <i>How a place or situation changes over time.</i>   |
| Crossing the stage  | <i>Moving through a space in a way that draws attention and dynamic.</i>                                   |
| Blocking position   | <i>A specific placement in space where a person or an object is intentionally placed to steer focus.</i>   |
| Level change        | <i>A movement where a person is changing their height (for example through stairs, podiums or slopes).</i> |

|                    |  |
|--------------------|--|
| Motivated movement | <i>A movement that has a clear reason and affect the space's dramaturgy.</i>   |
| Dramatic pause     | <i>An empty or quiet place that creates an emotional or visual emphasis.</i>   |
| Tableau            | <i>A frozen scene in which people are arranged in a visual composition.</i>  |
| Focal point        | <i>The visually or emotionally dominant element in a composition that naturally draws the viewer's attention. In scenography, it often guides the audience's gaze to key actions or meanings on stage.</i>     |
| Framing            | <i>The deliberate use of architectural or scenic elements to enclose or isolate parts of a space or scene. Framing shapes the audience's perception and can suggest intimacy, focus, or detachment.</i>        |
| Resolution         | <i>The visual or spatial conclusion of a scene, moment, or sequence. It may involve a shift in light, movement, or scenery that symbolically or practically "resolves" the narrative or emotional tension.</i> |
| Negative space     | <i>The empty or unoccupied space around or between objects or people. In scenography, negative space is a powerful tool to create contrast, rhythm, and silence.</i>   |



### The scenographic components

One cannot delve into the theory of scenography without discussing colour, light, materiality, and composition. These elements play crucial roles in shaping the visual language of a performance, influencing not only aesthetics but also the audience's perception, emotional response, and interpretation of the stage space.

This part of the theory explores these four key aspects of scenography, analysing their function through theoretical perspectives and practical examples.

*Picture 4. Alcina by Lars-Åke Thessman*  
A monochromatic sketch over the play Alcina.

## Colour

Colour has, since ancient times, been a marker of age, status and hierarchy in scenery (Howard, 2018). Beyond its symbolic function, colour also serves a perceptual function in scenography, guiding the audience's gaze and shaping how the stage is experienced. Pamela Howard (2018) describes colour selection as a compositional decision akin to a musician choosing a key. Once a scenographer has established a colour palette, it creates a framework within which all other colours are placed, ensuring a cohesive and structured visual space. This analogy shows how colour not only is an aesthetic aspect but also a structured principle for scenic creation.

Colour also carries a strong emotional significance, evoking responses that, while subjective, can be shaped through the scenographer's choices and the context in which the colours appear. Howard (2018) emphasizes that colour can extend beyond merely the coloured object and be associated with something more abstract or subconscious, which enhances its dramaturgical potential. For example, a dominating colour palette can enhance its thematic message, such as the monochromatic palette of Alcina (Thessmans, 2011) where the black colour was used to depict melancholy and unease.

Thus, colour in scenography is far from a mere decorative aspect—it is an active storytelling tool that shapes perception, enhances emotional atmospheres, and creates a unified visual identity for a production.

*Figure 3. Colour associations*

Illustration over what emotions and associations colour can bear. The associations used are taken from Adobe (n.d), and are just a few of the ones mentioned.

|   |   |
|---|---|
|    | <i>Positive: sympathy, health, love<br/>Negative: weakness, inhibition</i>                      |
|    | <i>Positive: excitement, strength, passion<br/>Negative: aggression, danger, defiance</i>       |
|   | <i>Positive: warmth, happiness, fun<br/>Negative: frustration, warning</i>                      |
|  | <i>Positive: creativity, friendliness, sunlight<br/>Negative: deceit, depression, cowardice</i> |
|  | <i>Positive: balance, peace, good luck<br/>Negative: jealousy, illness, greed</i>               |
|  | <i>Positive: efficiency, intelligence, calm<br/>Negative: cold, obscurity, depression</i>       |
|  | <i>Positive: luxury, quality, wisdom<br/>Negative: arrogance, gaudiness</i>                     |
|  | <i>Positive: reliable, tradition, richness<br/>Negative: dull, poverty, heaviness</i>           |
|  | <i>Positive: elegance, neutrality, respect<br/>Negative: decay, pollution, blandness</i>        |
|  | <i>Positive: sophistication, wealth, security<br/>Negative: fear, mourning, oppressive</i>      |
|  | <i>Positive: purity, hope, simplicity<br/>Negative: emptiness, unfriendly</i>                   |

als such as glass and water are used to create interactive reflections and new spatial dimensions. These choices influence how the audience perceives movement and depth, demonstrating how materiality can shape the scenographic experience.

Materiality, therefore, becomes a crucial factor in how a play is received. The combination of texture, light, and colour strengthens the dramaturgy and gives a production its unique visual identity.

### Light

Light is one of the most dynamic and transformative components in scenography. It defines the space, creates an atmosphere and directs the audience's attention. Through lightning, a stage can change from open and extensive to intimate and enclosed within seconds. The lights relation to colour and material is also central - reflective surfaces can enhance its effect while matt or dark surfaces absorb it, which affects the visual experience.

One of the first theorists to consider light as an active scenographic element rather than just a practical source of illumination was Adolphe Appia. In *Music and the Art of Theatre* (1899), he argues that light should be used to shape the space and the actors' bodies, rather than merely illuminating the set.

Light interacts with both color and material—reflective surfaces amplify its effect, while matte or dark materials absorb it, altering the visual experience. By manipulating light's color, direction, and intensity, scenographers and lighting designers can shape the audience's perception of time, space, and mood.

### Texture & Material

Texture and materiality are central aspects of scenography, since they influence both the visual experience and the interaction between actor, light and space. The choice of materials can drastically alter how scenography is perceived—whether monumental and robust or fleeting and ethereal. The surface qualities of materials—whether soft, rough, reflective, or matte—affect how the audience interprets a scene, forming different associations and emotional responses.

Arnold Aronson (2005) discusses how materiality in scenography is not only about the physical properties of space but also about shaping the audience's perception of the story. He argues that scenography always exists in relation to the actor, and materials become carriers of meaning through their use on stage.

A notable example is Es Devlin's work with mirror-based scenographies, where materi-



*Picture 5. Donmar warehouse by Es Devlin*  
Es Devlin continuously creates spacial poetry through the contrast between transparent materials , lighting and tactile surfaces - just as she does here in a scenography from FututeFest in 2016.

*Picture 6. Einstein on the Beach by Robert Wilson and Philip Glass*

Composition defined by strict symmetry and horizontal division. The repetitive placement of bodies, light and architectonic elements creates a graphic scenery where time and movement become visually coded.



changes. Howard points out that an effective composition should be viewed over time rather than as a fixed image, as theatre is inherently dynamic.

It is also important to think about spatial hierarchy and visual dynamics. How the scenography is organized affects the relationship between characters and their position of power on stage. For example, a centralized composition can give a feeling of authority and stability, while asymmetrical or diagonal compositions can signalize movement, conflict or insecurity. The use of depth and perspective can also be used to create illusions of distance or closeness. Pamela Howard continues with the parallels between scenic composition and music, where rhythm and dynamics are created through how different elements are distributed on stage. She describes composition as a series of visual “chords” and “keys” that together build up a whole.

### **Composition**

Composition is one of the fundamental tools for the scenographer, determining the placement of scenographic elements to create both visual balance and dramaturgical impact. Pamela Howard (2018) emphasizes that scenography is never static - it is a dynamic whole that changes through movement, light and the shifting perspective of the audience.

Used as a storytelling tool, composition guides the audience’s gaze and influences how a scene is interpreted. Howard means that the work of the scenographer resembles that of an artist or a musician who organizes spatial elements to create a dramatic effect. By working with lines, shapes and directions the scenographer can establish tension, dynamics or harmony in the scenery.

An essential aspect of composition is movement and transformation - the way scenographic elements shift due to actor movement, scene transitions, and lighting

Pamela Howard shows that composition in scenography not only is about aesthetics, but about how the room is used to strengthen the storytelling. Through working with movement, hierarchy and rhythm the scenographer can affect how the audience experiences and create a visually engaging experience.

Scenography is a multi-layered artistic practice where colour, materiality, light, and composition work together to create a compelling visual and emotional experience. Colour serves as both a guiding and symbolic force, materiality shapes spatial perception, light defines the environment, and composition orchestrates the audience’s focus and interpretation.

By understanding and deliberately applying these elements, a scenographer can craft a scenographic language that not only supports the narrative but also deepens the audience’s engagement with the performance.

The

perform





*Picture 7. View over Idrottshallen, Gothenburg Jubilee 1923*

A collection of pictures taken during the 1923 Jubilee are central in the realisation to the design of the performance, one of them is this one taken viewing Idrottshallen with Näckrosdammen in the foreground.

The methods applied in this thesis aims to incorporate scenographic techniques into architecture. The method is divided into four different parts. They all begin in an understanding of the scenographic component so that all that is represented follow these guidelines - such as how scenographer's work with colour, light and texture - and take them into account into all parts.

### **The stage**

The first part creates an understanding of the site through a scenographic lens. The analysis of the site is divided into several different maps, creating an understanding of the important elements such as emotions, lighting, viewpoints and the composition that exists. In addition to this, through the lens of collective memory the site is also analysed by it's historical narrative.

### **The manuscript**

What manuscript is going to be used? This is the second part of the method, finding a manuscript that will work well on the chosen site and develop an understanding of the story - both in a rational and emotional sense. In scenography questions that are important are ones such as; Who is the narrator? How can the text be divided into acts and scenes, with appropriate pauses? Is the audience an active part of the manuscript or not? The questions all lay ground for the next step

*The performance* which is understanding how the manuscript can be translated into the physical space. Connected to the collective memory this part of the method also takes into account the background of the manuscript and the history that comes with it.

### **The translation**

The next step is to take the manuscript and the site and combine them. By working with the scenographic analysis of the site and knowing the rhythm and emotional sphere of the manuscript all together with the history, the next step is about combining them and finding means in which the site can be used to represent something within the manuscript and how the manuscript can represent something of the site. It is about finding a common language within the two can exist.

### **The model**

The final step that all of the previous ones has led up to is the model. The model is a representation of the scenography on site. By working in model the scenography can be understood in a physical way how the people will move and what they will experience from different vantage points. Similar to the work of the scenographer the model will be a physical one, in addition to a digital one, in scale 1:25, representing the important sequences and scenes within the installation

## **The stage**

The decision to work with Näckrosdammen is based on several key aspects: its role within the urban landscape of Gothenburg, its historical importance from the 1923 Jubilee Exhibition, and its inherent scenographic qualities that allow for a dynamic and creative audience experience.

Näckrosdammen is one of the few remaining constructions from the 1923 Jubilee Exhibition (Humlesjö, Siska, Åhlfeldt, Johan, Strinnholm, Anders et al. 2023). Originally planned for 1921 to mark the city's 300-year anniversary, the exhibition was delayed due to economic challenges in the aftermath of World War I. With over 4.2 million visitors, it encompassed vast areas of Gothenburg and introduced some of the city's most iconic landmarks, such as the art museum, the botanical gardens, and Slottsskogsvallen. The area surrounding Näckrosdammen housed the "Historical Memory" section of the exhibition, including pavilions related to trade, seafaring and art.

Through a scenographic lens, Näckrosdammen naturally becomes a theatre in the round. The water serves as a central stage where various acts unfold. The surrounding benches offer static viewpoints, while pedestrian movement through the park allows for shifting, dynamic encounters - blurring the line between performer and observer.

- **History:** A contextual plan of the 1923 Jubilee Exhibition highlights how the site once formed part of a larger narrative of national identity, memory, and display. The map anchors the site within this thesis and reveals traces that remain in today's park layout.
- **Composition:** This map interprets the spatial organization of the site using scenographic principles of framing, focus, contrast, and rhythm. The analysis exposes the implicit dramaturgy of the park's design and how spatial elements guide perception and movement.
- **Emotion:** Based on theories of colour and emotion, this map identifies zones of comfort, melancholy, tension, and openness. It provides a soft reading of how the site might be felt, rather than just understood visually or functionally.
- **Artificial Lighting:** This evening-time analysis traces how the park transforms under artificial lighting. It examines contrasts between lit and unlit areas and considers how light contributes to the spatial narrative, orientation, and emotional register of the site at night.
- **Material and Tactility:** The final analysis focuses on materials present on site and their sensory impact. Materials are catalogued and cross-referenced with emotional and tactile properties, accompanied by diagrams assessing permanence, porosity, warmth, and reflectivity. Together, this forms a material dramaturgy, informing how texture and tone contribute to memory and experience.

To establish a deeper understanding of the site, a series of scenographically grounded analyses have been carried out. These are presented in the form of thematic maps and diagrams which interpret the site through scenographic theory, including composition, emotion, and material storytelling. These maps not only aim to translate traditional scenographic tools into spatial reading, but also form a foundation for future design decisions:



*Historical map - 1923, scale 1:1000*

The map visualizes the historical context of Näckrosdammen as part of the 1923 Jubilee Exhibition. It highlights the area's role within the "historical memory" section, revealing layers that still influence the site's spatial identity. This foundation becomes key in interpreting the site as both a cultural remnant and a scenographic backdrop.



1.



*Picture 8. Minareterna, Gothenburg Jubilee 1923*

Näckrosdammen is in the foreground. The picture is over viewing (from left to right) the Pergola, Minaerterna and Galliganis Italian bar.



*Picture 9. Same view May 2025*

Only trace left from the Jubilee is Näckrosdammen in itself. The greenery has become a big part of the sites identity. Picture taken by author (2025).

2.



*Picture 10. Minneshallen från Näckrosdammen, Gothenburg Jubilee 1923*

Näckrosdammen is in the foreground. Behind it (from left to right) the main restaurant, entrance to Handelsgatan, the building of the Department for Swedes Abroad, the Music pavilion and the exhibition for shipping, trade and fishing



*Picture 11. Same view May 2025*

Picture taken by author (2025).

3.



*Picture 12. Näckrosdammen, Gothenburg Jubilee 1923*

Part of Näckrosdammen. To the left Minneshallen and to the right the Art industry exhibition

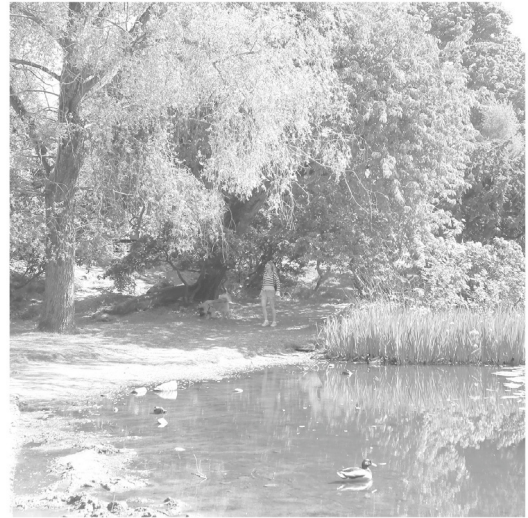

*Picture 13. Same view May 2025*

Location of the photograph is today a playground. Picture taken by author (2025).

4.



*Picture 14. View over Idrottshallen, Gothenburg Jubilee 1923*









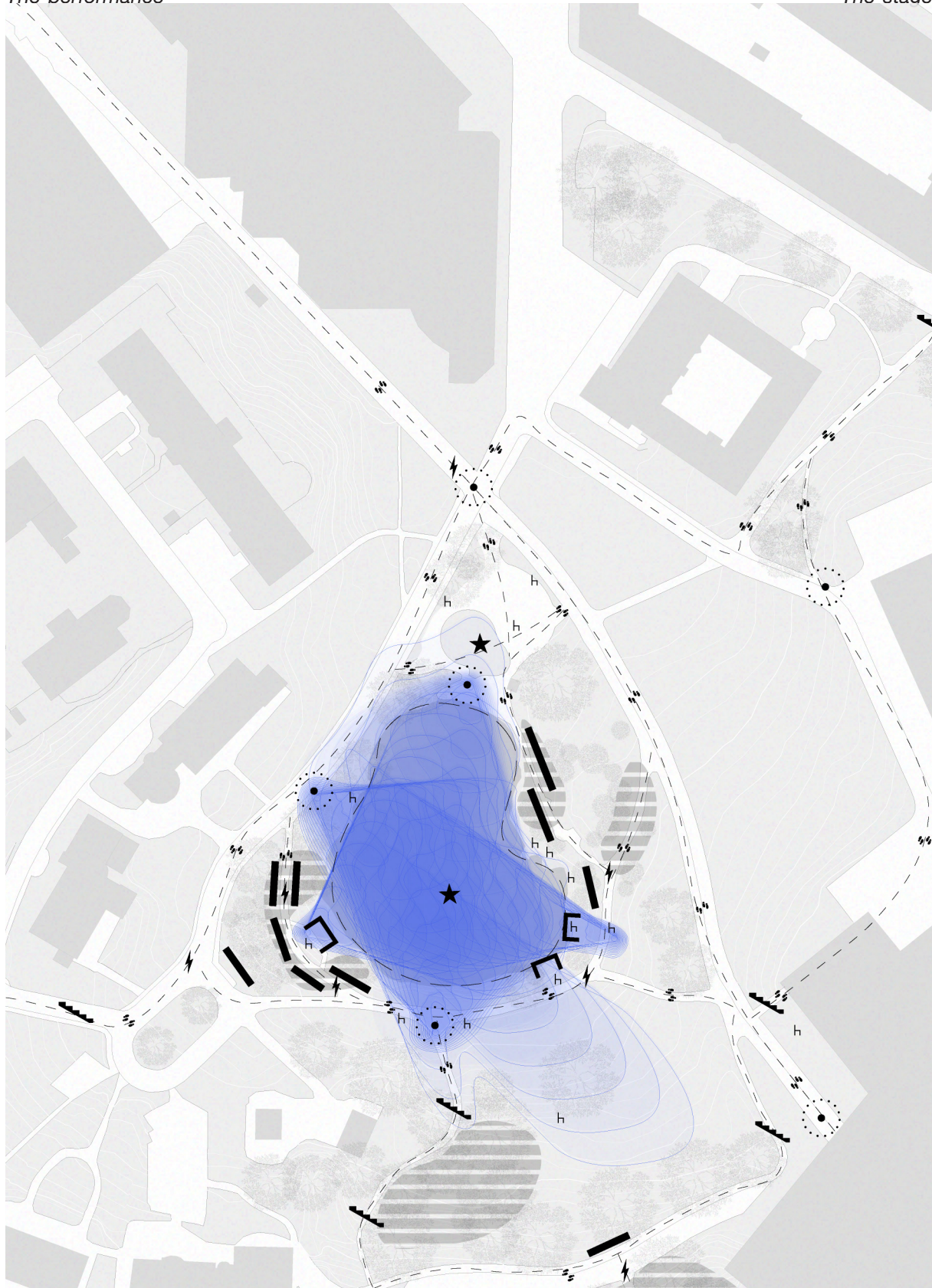



Näckrosdammen in the foreground, viewing Idrottshallen.



*Picture 15. Same view May 2025*

The shoreline is today overgrown by a varied collection of vegetation. Picture taken by author (2025).



-  *Blocking*
-  *Movement*
-  *Transition*
-  *Level change*
-  *Conflict*
-  *Resolution*
-  *Framing*
-  *Focal point*
-  *Negative space*
-  *Audience seating*
-  *Sight-lines*
-  *Shadows*

*Composition map - scenographic reading scale  
1:800*

This composition map reinterprets the spatial structure through scenographic principles: framing, rhythm, contrast, and focus. It reveals how visual sight-lines, boundaries, and movement contribute to a staged experience. The reading offers a dramaturgical understanding of space, proposing that the park itself acts as a pre-choreographed performance zone.



The performance

The stage

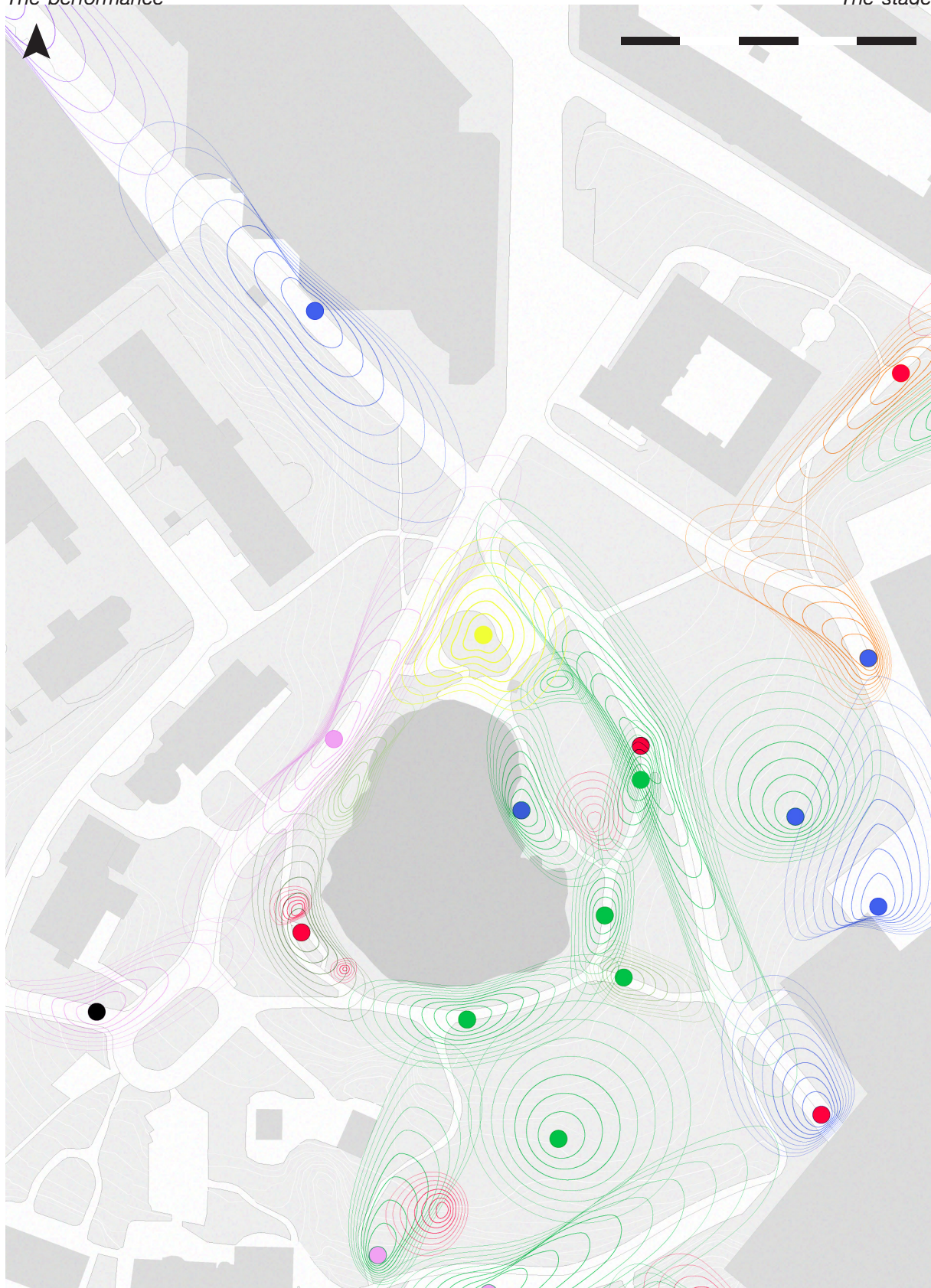

-  *Positive: sympathy, health, love*  
*Negative: weakness, inhibition*
-  *Positive: excitement, strength, passion*  
*Negative: aggression, danger, defiance*
-  *Positive: warmth, happiness, energy*  
*Negative: frustration, warning*
-  *Positive: creativity, friendliness, sunlight*  
*Negative: deceit, depression, cowardice*
-  *Positive: balance, peace, good luck*  
*Negative: jealousy, illness, greed*
-  *Positive: efficiency, intelligence, calm*  
*Negative: cold, obscurity, depression*
-  *Positive: luxury, quality, wisdom*  
*Negative: arrogance, gaudiness*
-  *Positive: sophistication, wealth, security*  
*Negative: fear, mourning, oppressive*

*Emotional mapping - scale 1:800*

Using principles from colour theory and emotional scenography, this map illustrates how different areas of Näckrosdammen evoke contrasting moods—safety, melancholy, vibrancy, or exposure. The analysis is based on both colour impressions and spatial atmosphere, offering a subjective layer that complements material and structural readings.



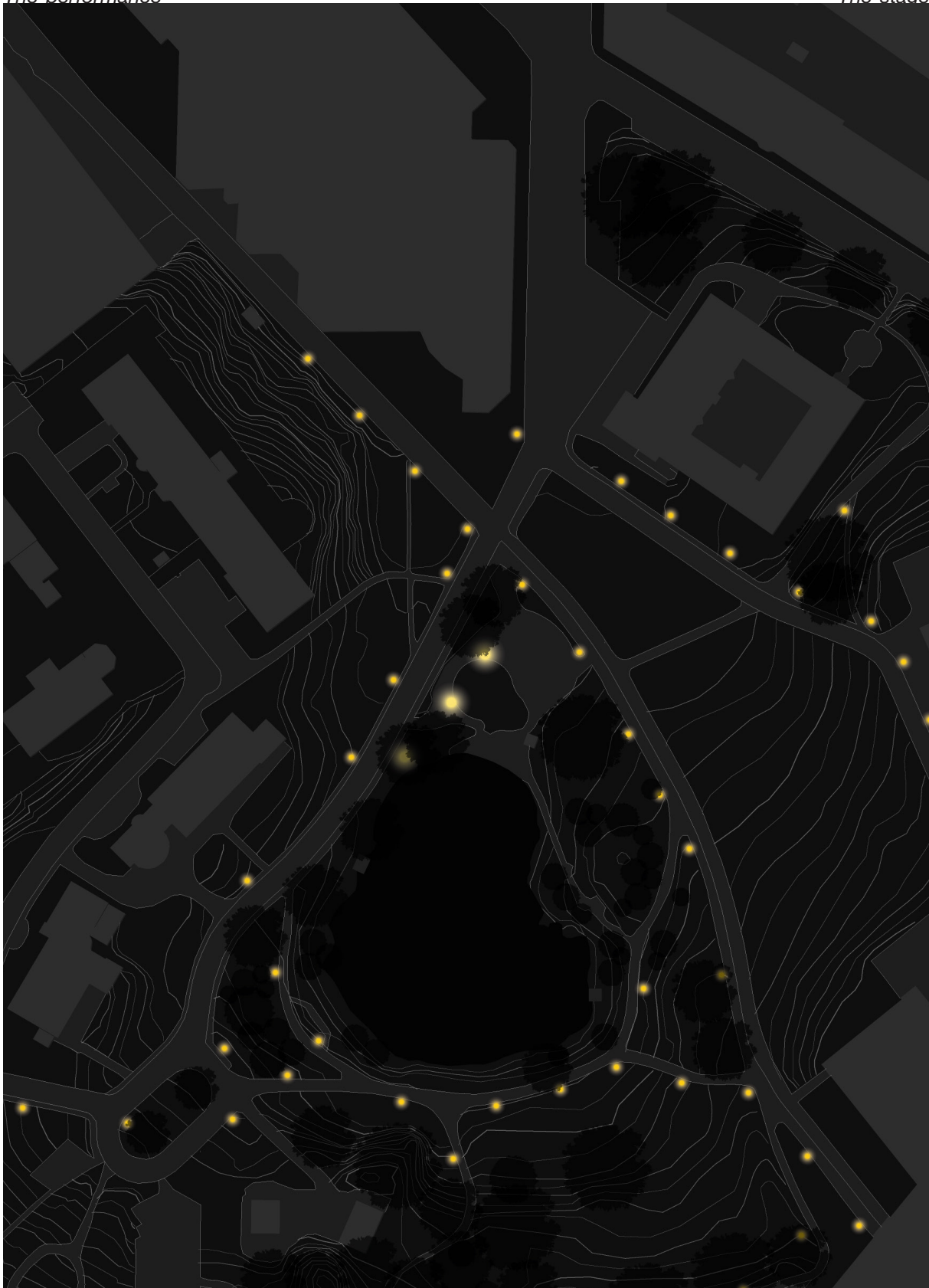

***Artificial lighting - scale 1:800***

This night-time lighting map shows how artificial light reshapes the site's scenographic experience. Lit and unlit zones are identified, with attention to how shadows, contrasts, and light directions influence visibility, atmosphere, and perceived safety. The analysis supports an understanding of how the site functions as an evening performance space.



***Materials - Tactile and emotional reading***

The material map catalogues surfaces found on site and pairs them with emotional and tactile responses. By evaluating each material's permanence, warmth, reflectivity, and porosity, the analysis forms a narrative around memory and physicality. This layer underlines how scenographic storytelling can emerge through texture, not just form.

*The stage*

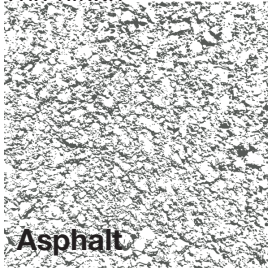

**Asphalt**

*Grey: Neutrality, urbanity, calmness*

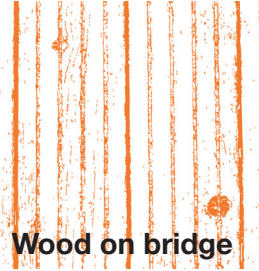

**Wood on bridge**

*Orange: Connection, energy, change, transition between places*

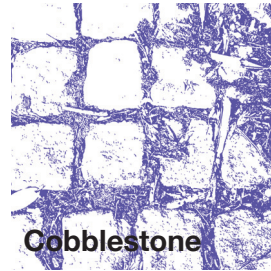

**Cobblestone**

*Purple: Culture, history, wisdom, timeless*

*The performance*

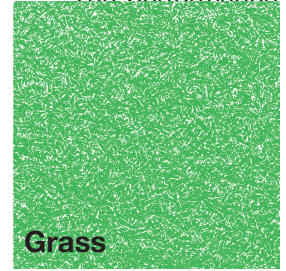

**Grass**

*Green: Health, nature, harmony, the constant movement of life*

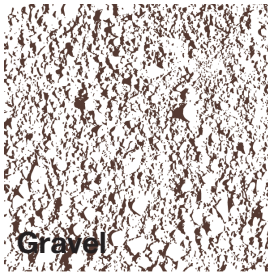

**Gravel**

*Brown: Simplicity, nature, earthy, natural tactility*

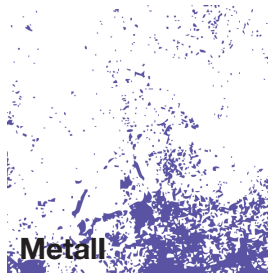

**Metal**

*Purple: Power, mystery, depth*



**Sand**

*Yellow: Playfulness, optimism, freedom*

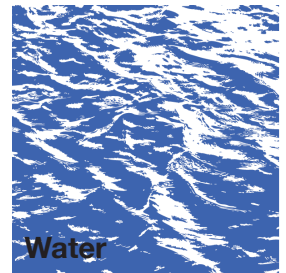

**Water**

*Blue: Tranquillity, stability, reliance*

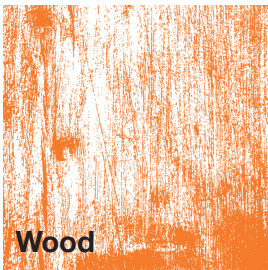

**Wood**

*Orange: Creativity, warmth, enthusiasm*



**Tree trunk**

*Yellow: Optimism, energy, viability*



**Mosscovered stone**

*Brown: Warmth, natural comfort, health, organic harmony*

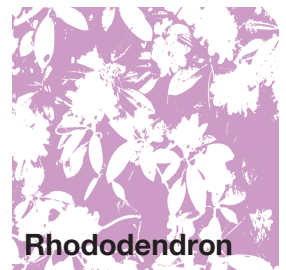

**Rhododendron**

*Pink: Romance, playfulness, calm, dreamy*



**Lamppost**

*Purple: Dusk, mystery, poetry*

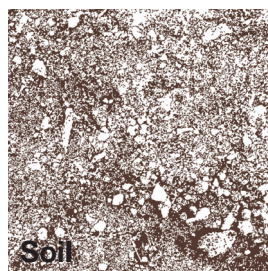

**Soil**

*Brown: Strength, reliance, closeness to nature, robust*

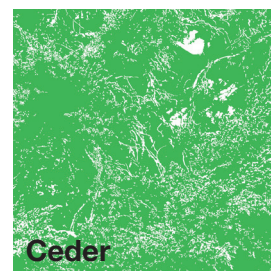

**Cedar**

*Green: Harmony, nature, growth, inner peace*

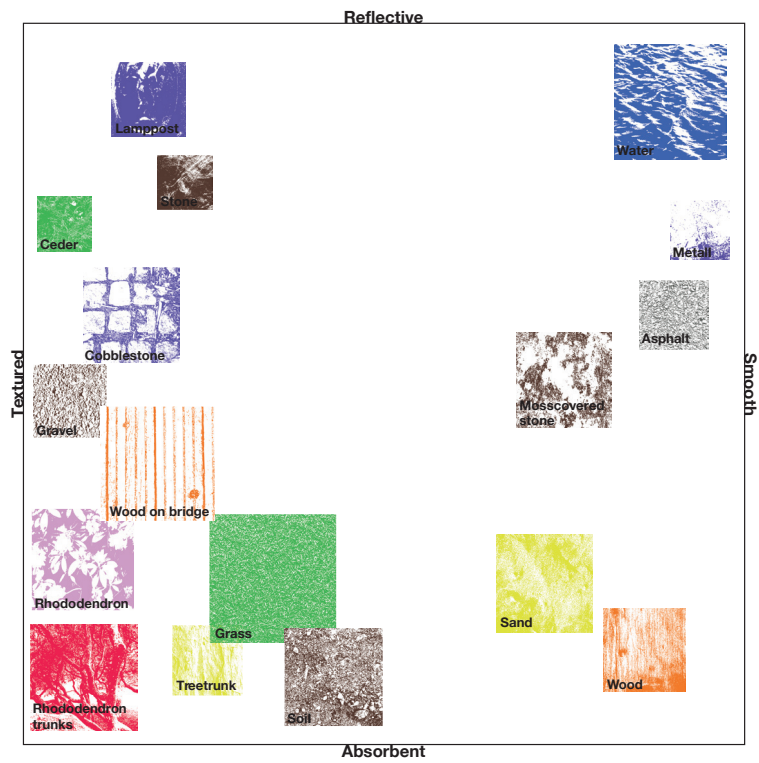
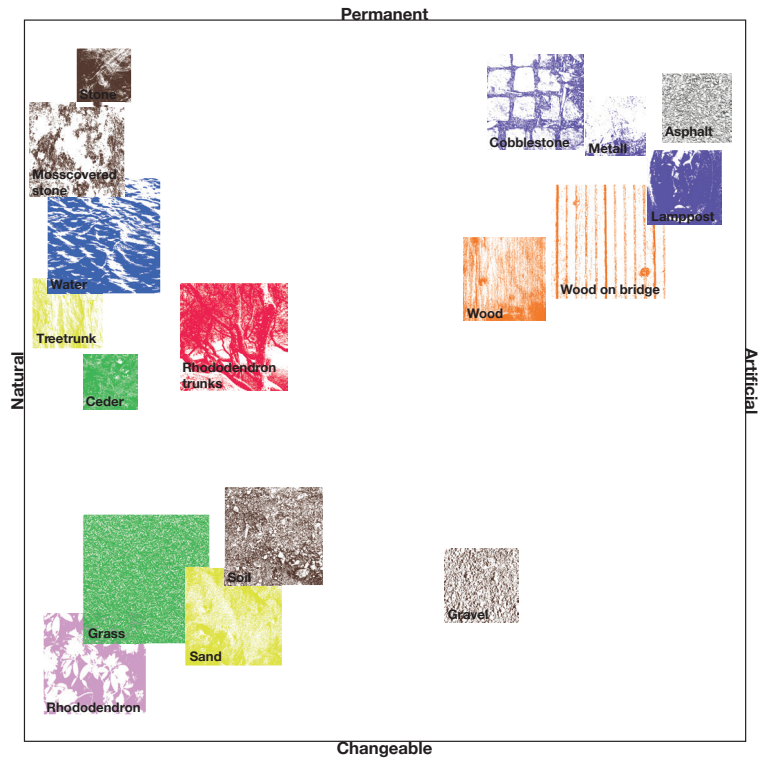

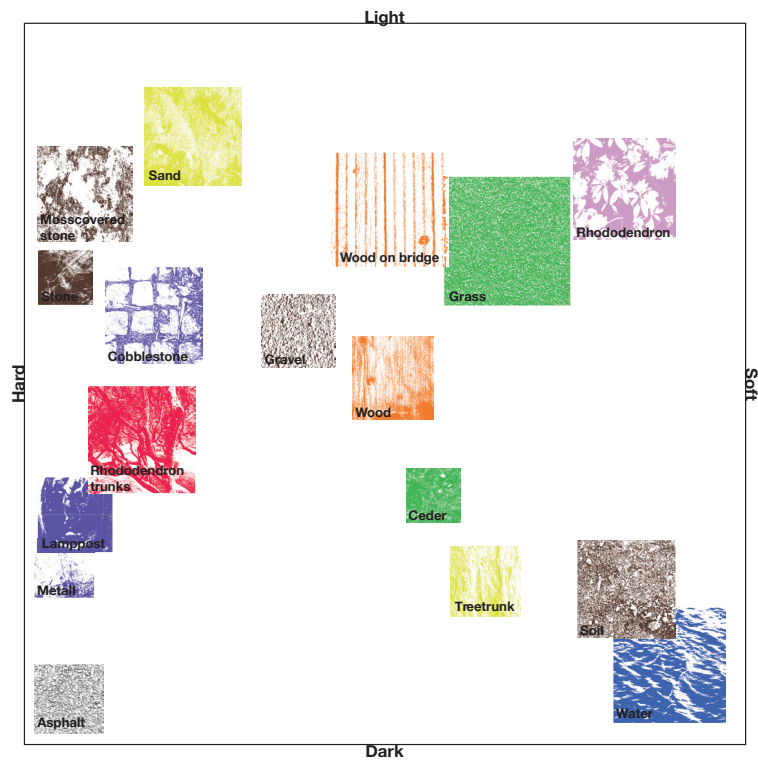
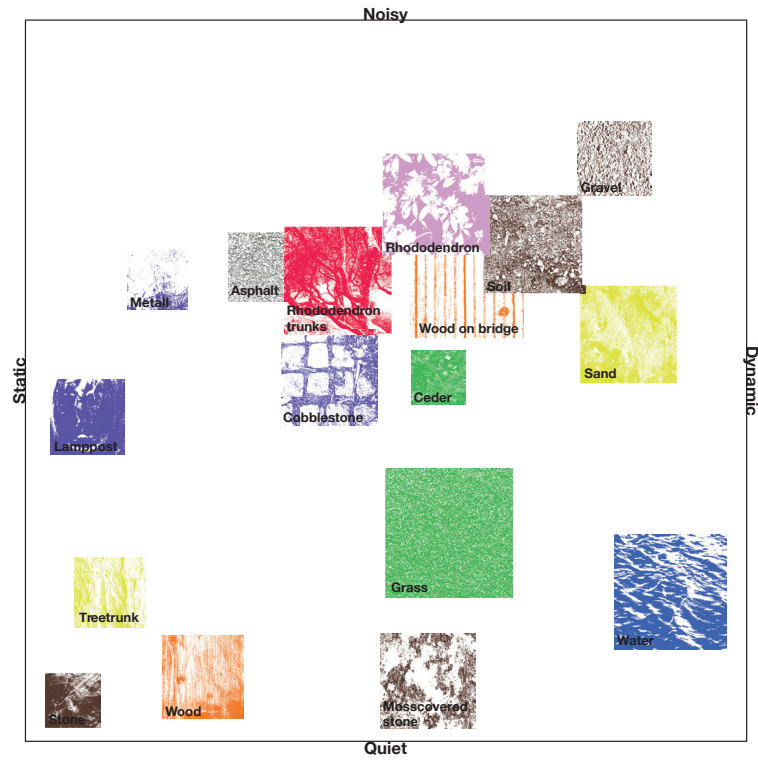

*The performance*

*The manuscript*

## The manuscript

Karin Boye (1900–1941) was a Swedish poet, born in Gothenburg, whose work frequently explored themes of resistance, transformation, and beauty (Tideholm, 1993). She made her literary debut in 1922 with *Moln*, a collection where her characteristic use of nature as a symbolic and metaphorical tool was already evident. This motif became even more pronounced in *För trädets skull*, which contains one of her most famous poems, *Ja visst gör det ont*.

Boye was active during the 1920s and 1930s, a time when modernism was challenging traditional literary norms. Her poetry reflects a shift in language, form, and symbolism that positioned her in contrast to more conservative voices in literature (Tideholm, 1993). The period was also marked by industrialization, urbanization, and the rise of the welfare state, all of which influenced the changing cultural landscape. Boye's poetry, with its focus on inner development and existential struggles,

captures the tension between individual experience and societal transformation. Modernism often explores the individual's internal struggles rather than the grand, external narratives. Boye's work reflects this by emphasizing the emotional and psychological process of change, rather than focusing on external events.

As a female in a male-dominated literary world, Boye challenged expectations simply by writing about personal, existential struggles rather than traditionally feminine themes. Her poetry often presents fluidity in emotions and identity, reflecting a resistance to rigid gender roles.

In the poetry of Boye, the narrator often takes on a personal yet universal voice. In the three poems that I have chosen - *Minne*, *Via Media* and *Ja visst gör det ont när knoppar brister* - the connection to nature shows in different ways. She uses nature metaphors to create imagery that resonates emotionally. Rather than telling the reader exactly how to feel, she allows space for subjective interpretation. With this possibility for personal reflection Boye invites the reader and audience to experience the work.

## ACT I

rhythm loosens, trembles. The second stanza expresses suspension: the moment before motion, caught between holding on and letting go. The image of a drop clinging to a branch might be echoed in the space through hovering structures, shadows or forms that seem poised mid-transition. In the final stanza, the poem softens. There is stillness here - acceptance. The rhythm evens, the emotional palette widens into light and clarity.

What begins as hesitation becomes a conscious act of transformation. Just as the poem holds both fragility and strength, the entry sequence invites the visitor to step into a space where growth is not only felt, but chosen.

*Ja visst gör det ont* traces the emotional and physical tension of transformation - how becoming something new is rarely soft. The poem moves from resistance and pain into release and quiet trust. At its core is a surrender: to let go of what is familiar, even when it hurts and step into the necessary unknown.

In the context of an installation, this poem defines the thresholds - the entry points. These are not just architectural beginnings but emotional ones. They mark the decision to move forward, to engage, to change. Like the bud in the poem, the visitor must choose to break open and begin.

The first stanza build around pressure - an internal weight, a fear of rupture. This can be mirrored materially through dense stone, rigid lines or asymmetries that make the body alert to its own position. The poem's tight rhythm echoes this tension: measured, controlled, held in. As the poem unfolds, its

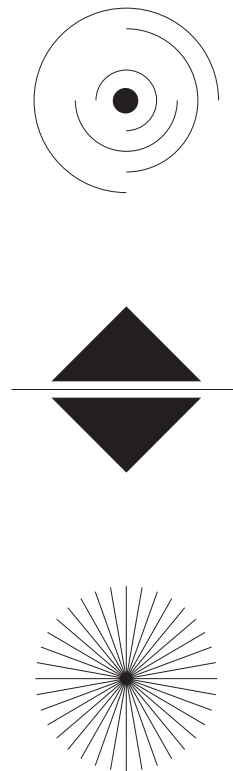

Figure 4. Rhythmic diagram

Illustration over the rhythm in the poem, from tension, to middleground ending up a release into freedom

Ja visst gör det ont när knoppar brister.  
 Varför skulle annars våren tveka?  
 Varför skulle all vår heta längtan  
 bindas i det frusna bitterbleka?  
 Höljet var ju knoppen hela vintern.  
 Vad är det för nytt, som tår och språnger?  
 Ja visst gör det ont när knoppar brister,  
 ont för det som växer  
 och det som stänger.

Ja nog är det svårt när droppar faller.  
 Skälvande av ängslan tungt de hänger,  
 klamrar sig vid kvisten, sväller, glider -  
 tyngden drar dem neråt, hur de klänger.  
 Svårt att vara oviss, rädd och delad,  
 svårt att känna djupet dra och kalla,  
 ändå sitta kvar och bara darra -  
 svårt att vilja stanna  
 och vilja falla.

Då, när det är värst och inget hjälper,  
 Brister som i jubel trädets knoppar.  
 Då, när ingen rädsla längre håller,  
 faller i ett glitter kvistens droppar  
 glömmmer att de skrämdes av det nya  
 glömmmer att de ängslades för färden -  
 känner en sekund sin största trygghet,  
 vilar i den tillit  
 som skapar världen.

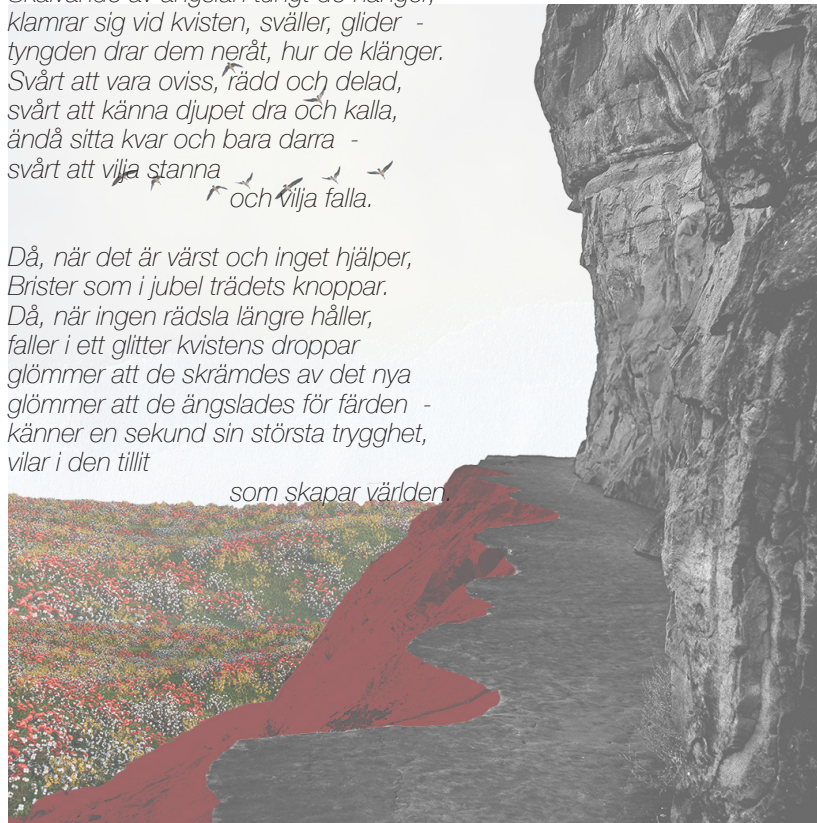

**Figure 5. Emotional collage**

Tension and pressure dissolve into stillness - represented through shifting textures and colors

## ACT II

*Via media* moves rhythmically and thematically from youthful restlessness - when emotion burns close to the skin - towards a centered stillness where joy and sorrow coexist. The poem begins in red heat, each line a pulse between highs and lows. But over time, the rhythm settles into balance, as if the speaker has learned how to breathe.

The shift is deeply material. The opening feels like glowing iron - too hot or too cold, almost unstable. But as the poem evolves, it cools into something grounded: weathered wood, softened stone, forms shaped by time. The architecture becomes not reactive but responsive.

*Via media* is a mediation on balance - not as compromise, but as dynamic clarity. Not neutrality, but active tension. In a scenographic reading, this balance might be explored through transitional materials: suspended fabric, reflective water, surfaces that hold light and shadow equally. The middle path is a place of strenght, not stasis.

*Via media* reminds us that freedom is not found in extremes, but in the willingness to remain in the tension between them. Through rhythm, form and symbolism, the poem becomes a mediation on the middle way: not as compromise, but as clarity.

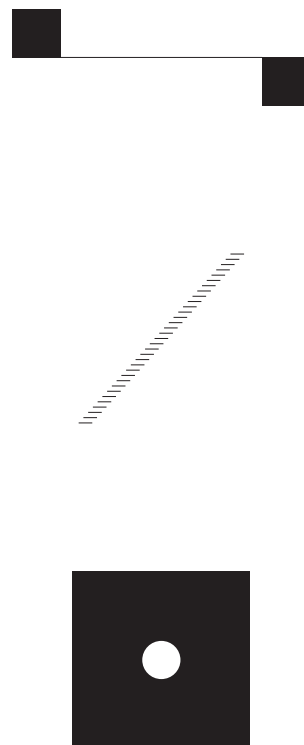
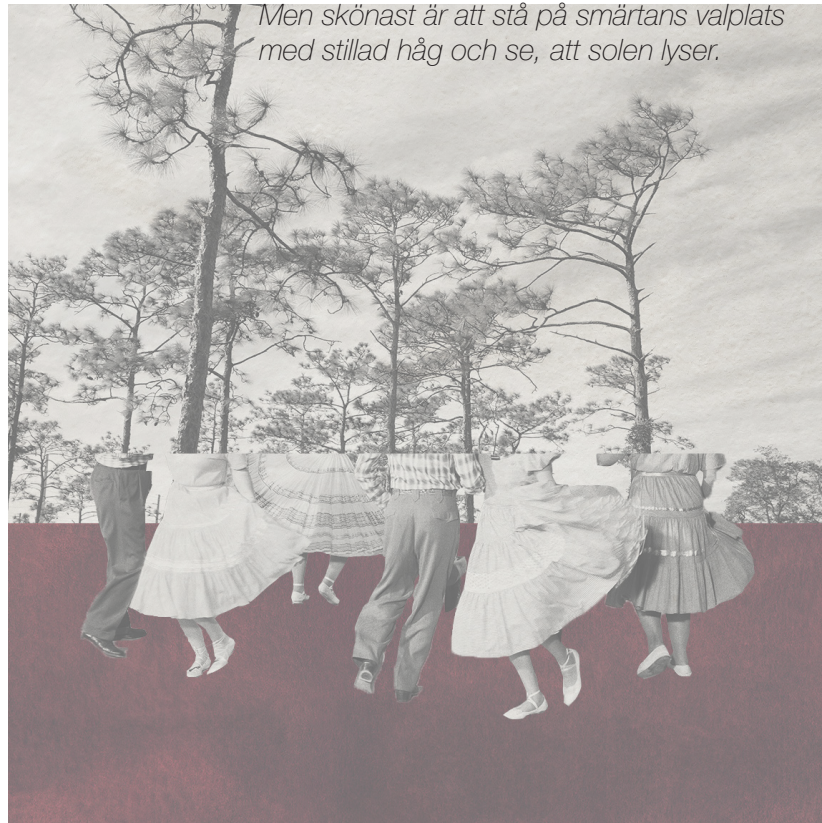

Figure 6. Rhythmic diagram

Erratic, sharp tension at first moving to a gradient which ends up into finding a security within.

*Via Media*

*Jag bad en gång om glädje utan gränser,  
jag bad en gång om sorg, som rymden ändlös.  
Månn blygsamheten växer till med åren?  
Skön, skön är glädjen, skön är också sorgen.  
Men skönast är att stå på smärtans valplats  
med stillad håg och se, att solen lyser.*

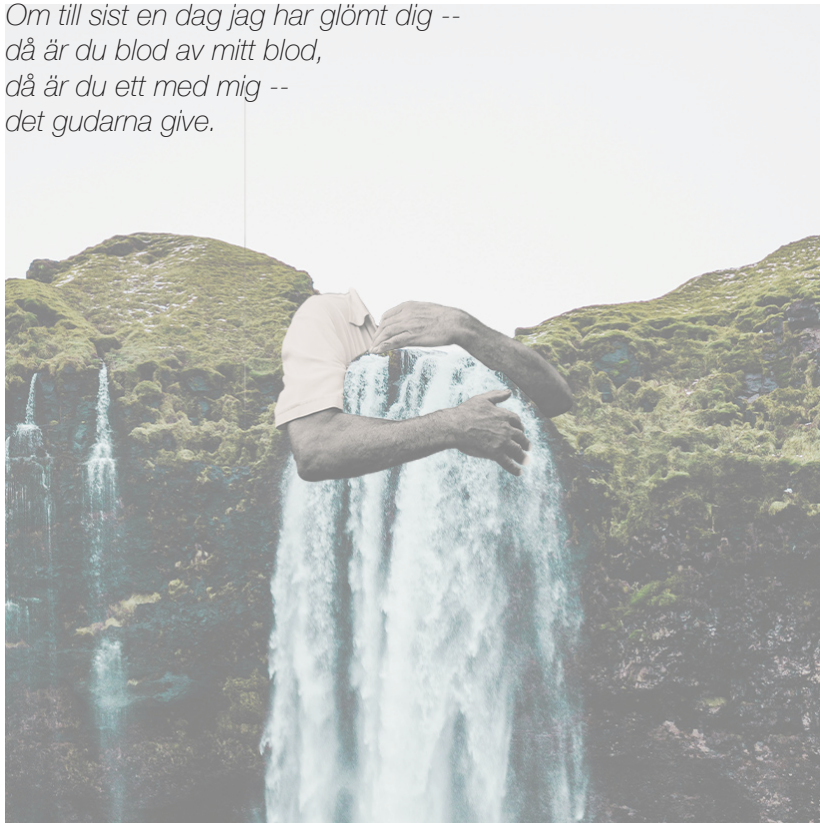

*Figure 7. Emotional collage*

From intense, radiant reds to the calmness of nature,  
reflecting on the acceptance of the extremes.

Minne

Stilla vill jag tacka mitt öde:  
aldrig jag mister dig helt.  
Som en pärla växer i musslan,  
så inom mig  
gror ditt daggiga väsen ljuvt.  
Om till sist en dag jag har glömt dig --  
då är du blod av mitt blod,  
då är du ett med mig --  
det gudarna give.



**Figure 8. Emotional collage**  
Soft tones - holding onto something impossible.

## ACT III

*Minne* traces how remembrance shifts - between conscious thought and something deeper, more embodied. The poem explores forgetting as a paradox: what is truly meaningful may fade from the mind, but lives within us, quietly woven into the soul.

The emotional trajectory of the poem begins in longing - trying to hold on to something slipping away. But slowly, this grasp relaxes into stillness, into presence, into trust. Memory becomes not something that possess, but something to be. Like a pearl forming in the dark, it grows silently until it is indistinguishable from the shell.

The rhythm follows this evolution. At first it hesitates - murmurs, breathes in fragments. As the poem continues, the cadence becomes more fluid, like water joining a wider flow. This transformation mirrors the emotional arc: from desire to acceptance.

Materially, *Minne* evokes translucency, softness and slow time. Think worn mesh and mist. Nothing is sharp, yet nothing disappears. These textures will shape the final act of the performance: where the memory feels fleeting yet always present.

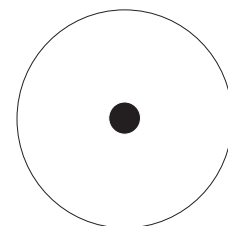

*Figure 9. Rhythmic diagram*

First wavering slowly moving forward to a stillness until finally ending up within.

## The translation

### A project between two readings

The proposal has emerged at the intersection of architecture and scenography - two languages, two gazes, two movements through space. As an architect, I have searched for structure, function and weight. As a scenographer, I have listened to rhythms, moods and poetic whims.

It is in the interplay between these two ways of understanding the place that the project has taken shape. The poem has become a drawing. Material has acquired memory. The movement through the place has become a script. Here the scene begins.

### Projected images on the existing landscape

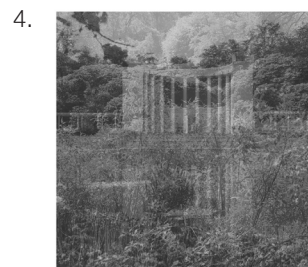
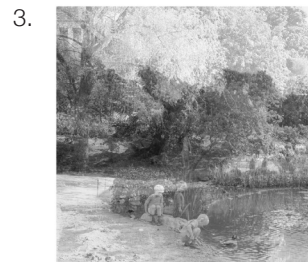

### Plan scale 1:400

Plan of the site with historical pictures that will be projected.



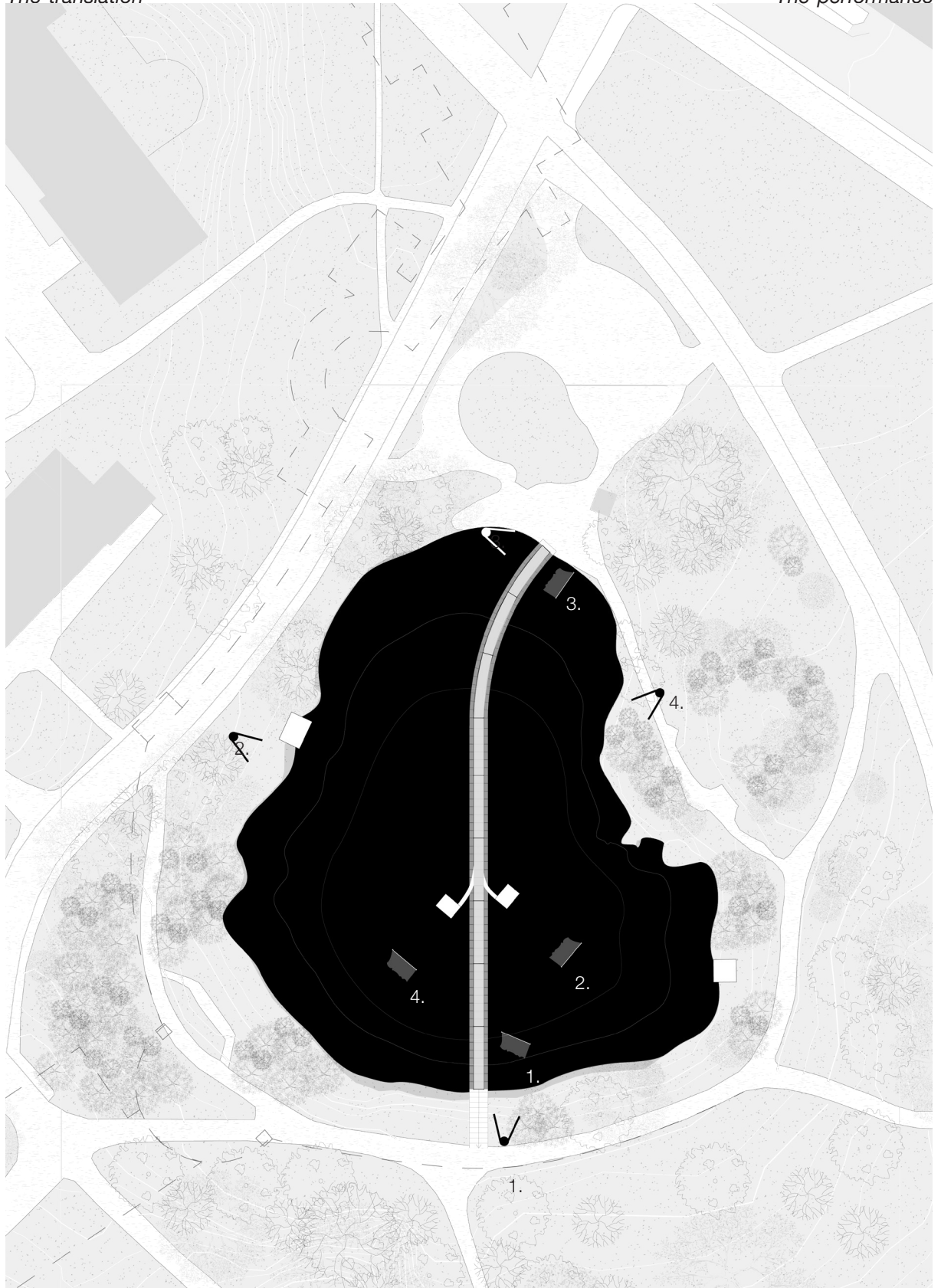



**Section scale 1:200**

Section through Näckrosdammen, where the bridge barely touches the landscape



0 2 10 m

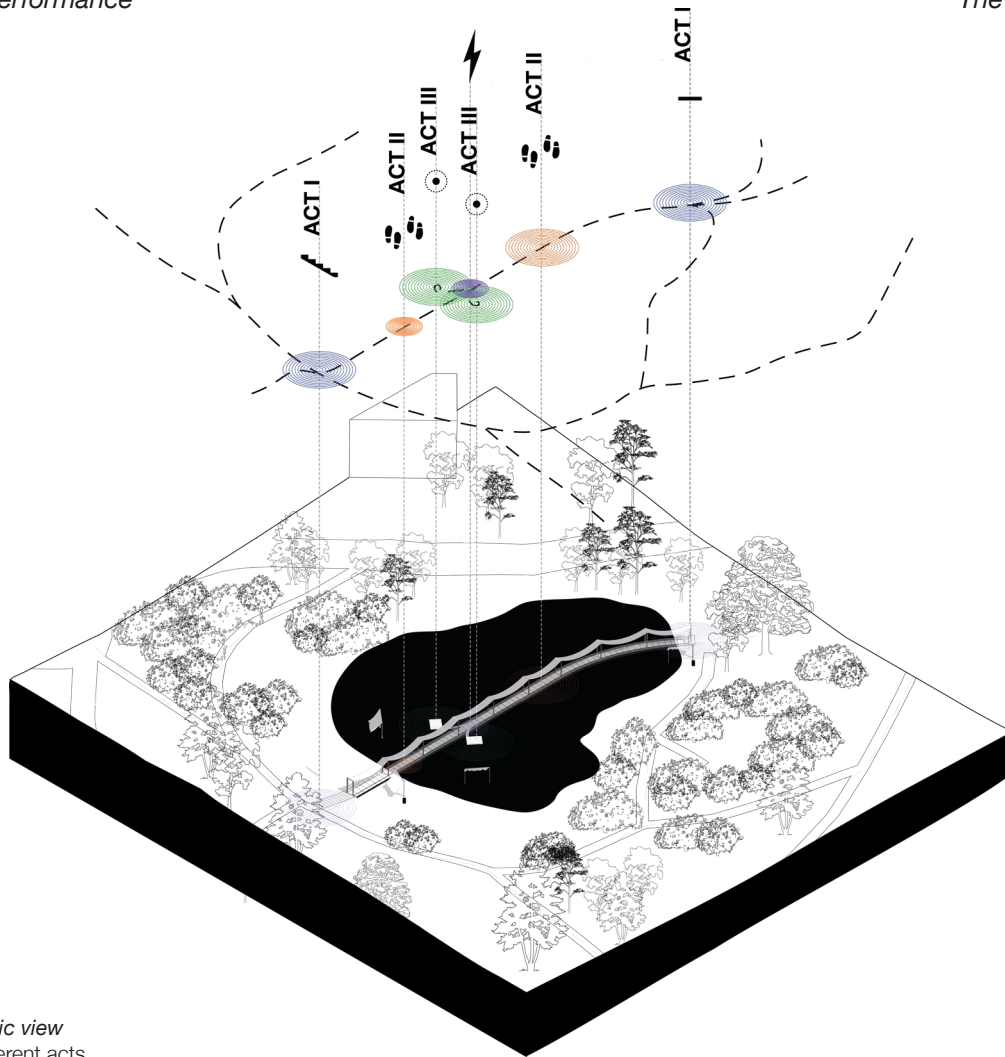

Isometric view  
The different acts

### ACT I

It begins with hesitation. The body stops before the transition, meeting a resistance. Here you find a stillness and the visitor makes a choice to experience. The poetry has already started to speak "Ja visst gör det ont". The materials are heavy stone, the surfaces matt. Here there is a charge, an expectation - as if standing in front of a curtain waiting to rise.

### ACT II

Then you take the step out, to the inbetween. Here movement gets body - it continues, it hovers. The bridge carries but is not obvious. It is light and heavy at the same time. The granite is floating, the oak is submerged under water, the fabric shifts in the wind. It

is a middle act, a negotiation between two conditions - as in *Via Media* where the poetry speaks of existing between extremes. Here there are contrasts but also balance, a place to be in without defining.

### ACT III

Then you stop. The tempo is slower, the sounds are dampened. Here you find a space for remembering. The scenographic frame embracing without enclosing. Below the stone you discover the bog oak - the past is always present. Here memory becomes something not only recalled but something you stand on. Sometimes showing in the projections, sometimes not. Just as memory itself.

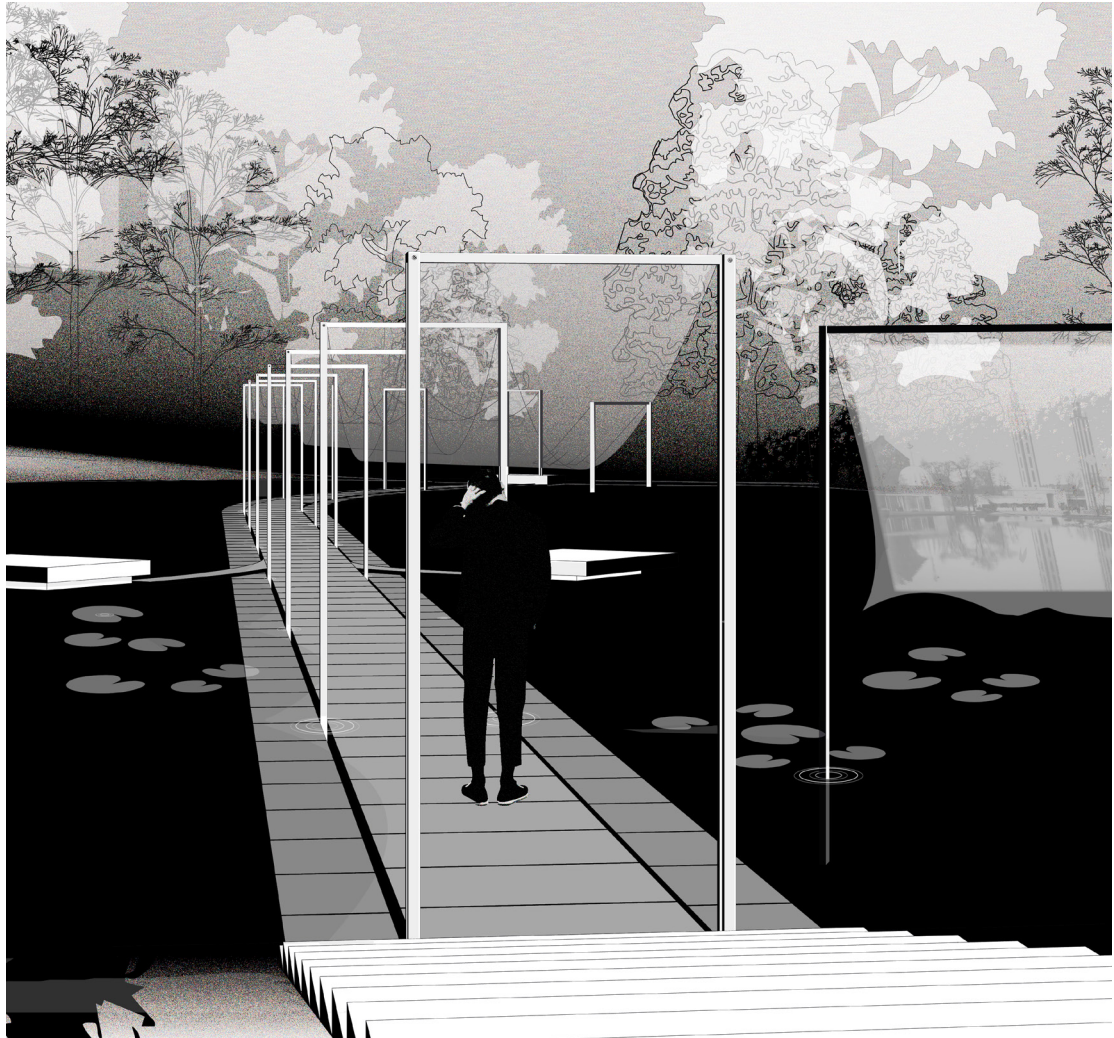

*Perspective entrance south*

ACT I - Stairs are creating a sense of action, you view the first historical picture capturing the Minarets.

*The performance*

*The translation*

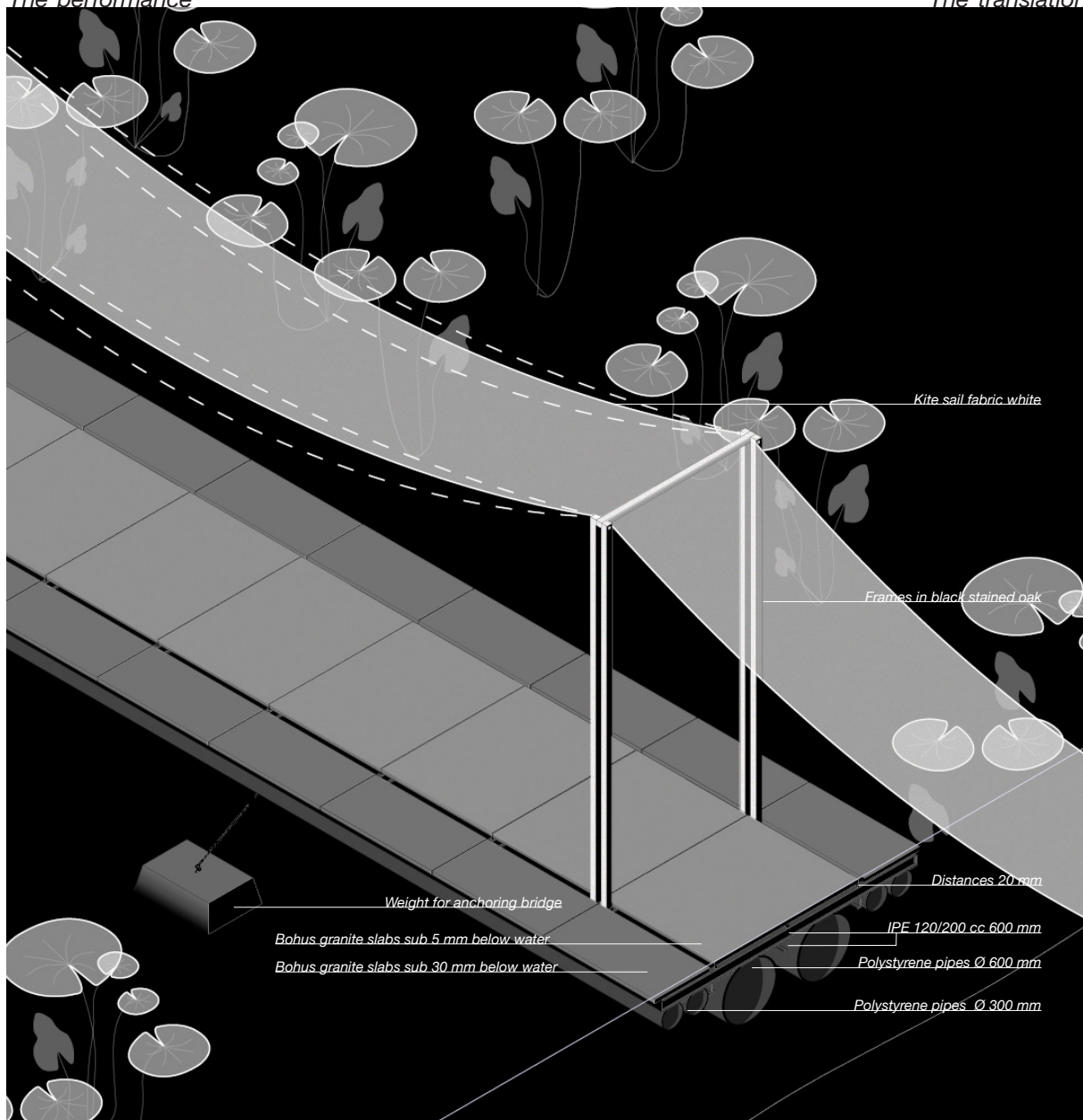

*Detail drawing scale 1:50*  
Bridge

0 50 250 cm

*Perspective entrance north*  
ACT I - the block of granite with the engraved text of the poem "Ja visst gör det ont", creating a sense of intention.

The translation

The performance

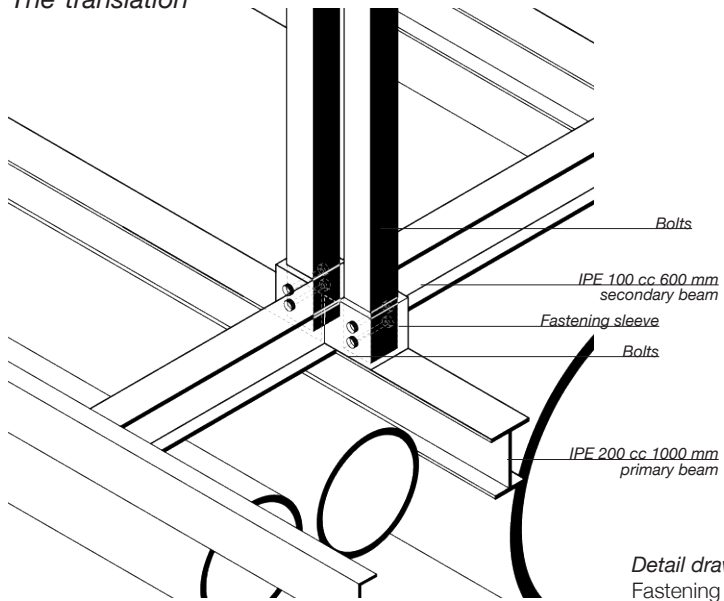

Detail drawing 1:10  
Fastening

0 10 30 cm

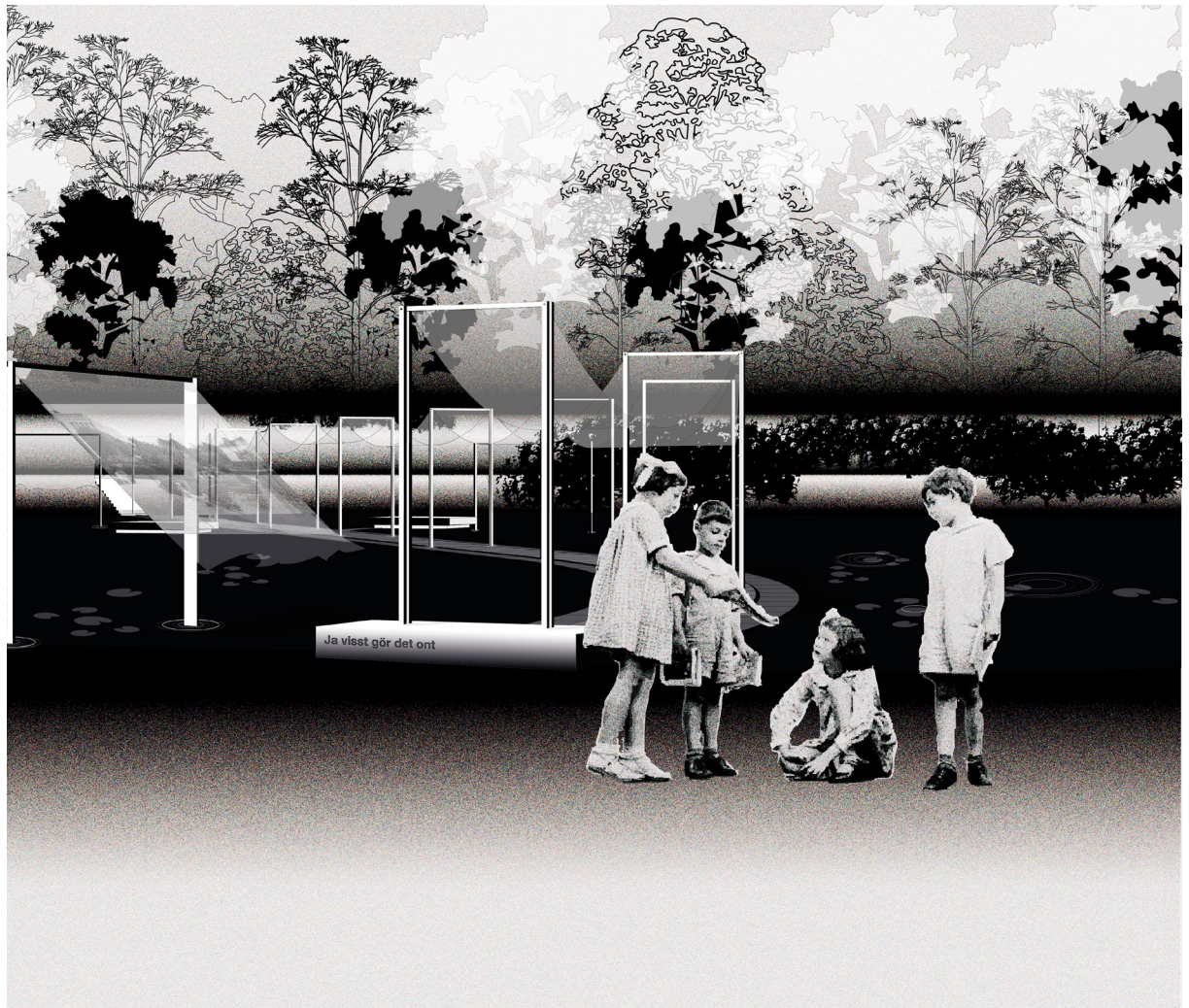

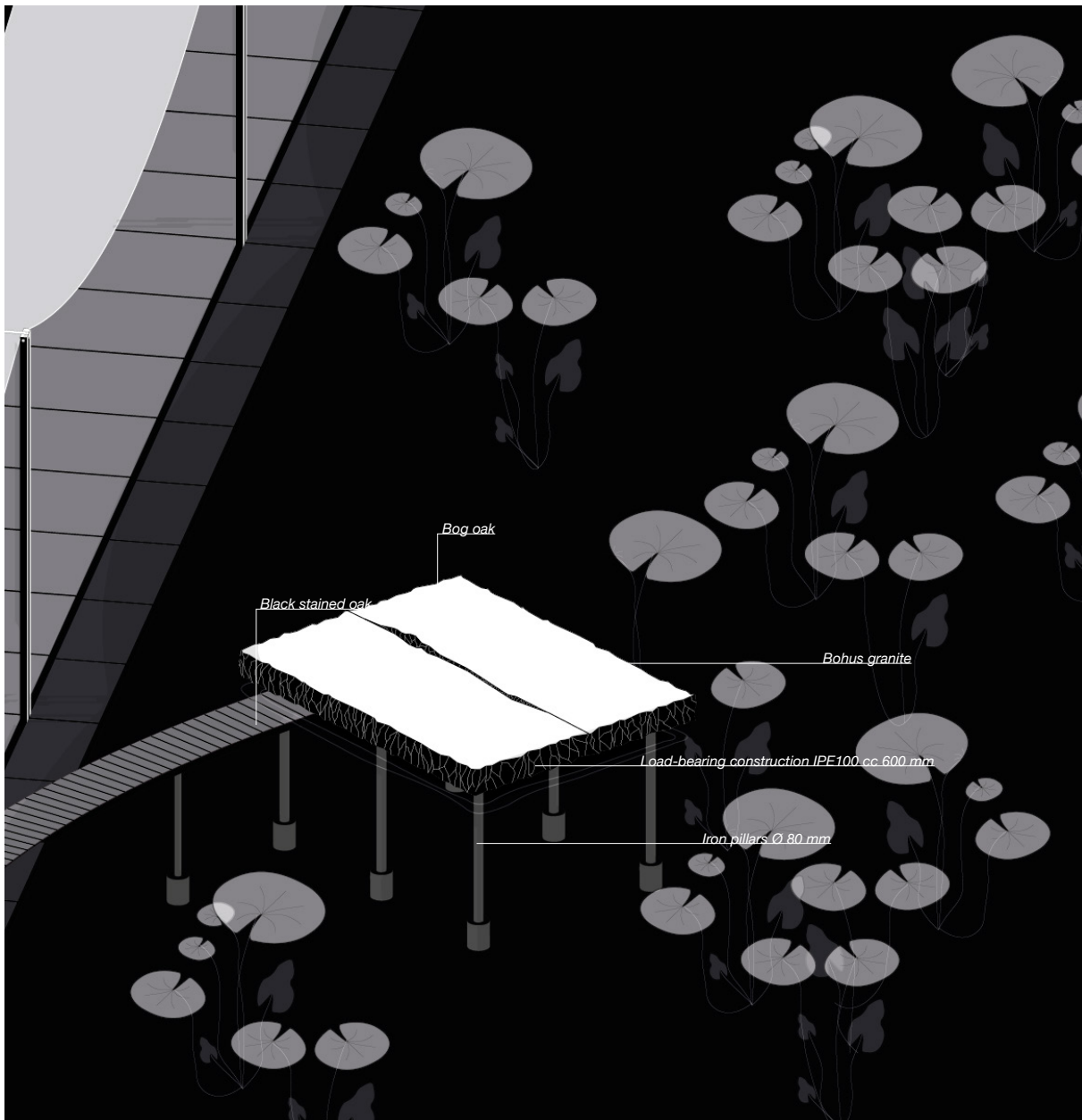

Detail drawing scale 1:50

Granite slab floating just above the surface, reflecting the stillness of the dam. Bog oak is hidden in the crack, waiting to be noticed.

0 50 250 cm

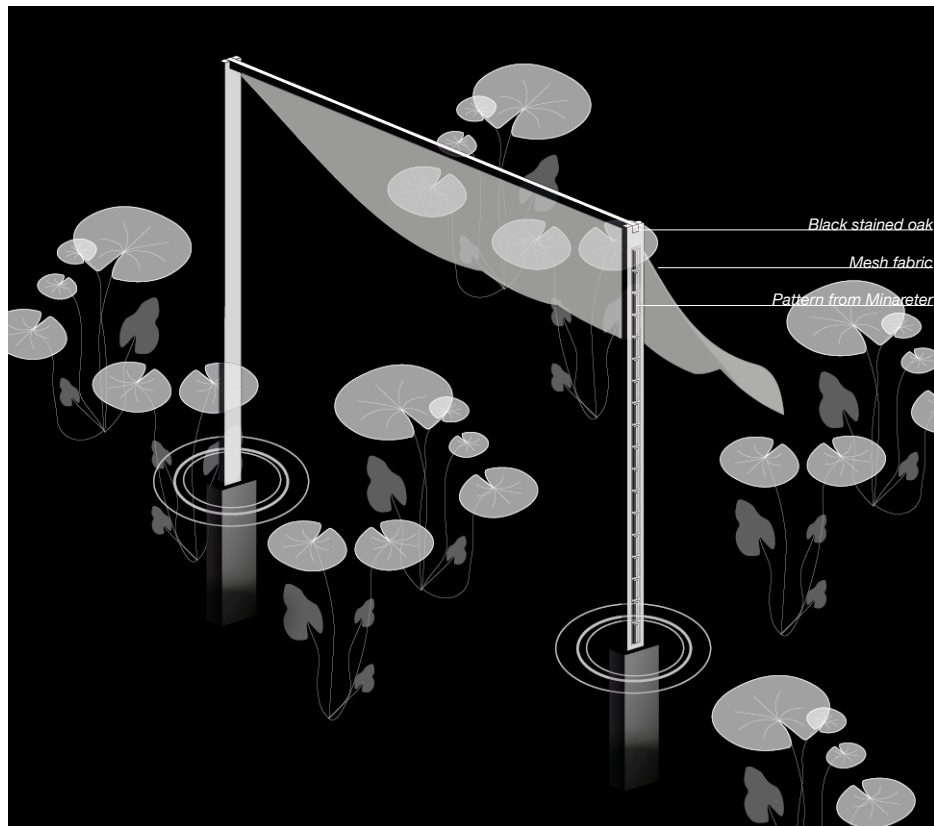

*Detail drawing scale 1:50*  
Memory frames aligned with photographs from 1923.

## The model

- The Bohus granite is heavy and still, grounded in time. The use of Bohus granite has historically been very common in the city's public space.
- The bog oak lies submerged, revealed through a rupture - a memory surfacing. Bog oak is also an material that has lied submerged for a long period of time and therefore becomes a carrier of history in itself.
- The reflective and mesh fabrics differ in tone and tactility, creating dialogue between movement and stillness, between now and then.

In addition, a conceptual model explores the projections within the memory frames - ephemeral, fleeting moment that appear only in specific light conditions. The mesh surface becomes transient screen, catching layer of visual memory and acting as a scenographic device for remembrance. This model captures the impermanence and delicacy of memory itself - never fixed, always transforming.

The models in this project serve not only as scaled representations but as spatial manuscripts. Each one gives physical form to the scenographic thinking that underlies the proposal - where rhythm, material, light and absence all contribute to the storytelling.

The dark perimeter of each model is a reinterpretation of the theatrical edge - a threshold into a spatial performance. Within each frame, the visitor is invited to observe, project and dwell in the transition between poetry and place.

The landscape model at 1:200 presents the full bridge as it cuts through Näckrosdammen, anchored in its topological and historical context. The dark, layered base references the scenographic black box - a theatrical container - but here it becomes landscape, structure and void. The bridge floats over it as an installation both reveals and reframes the site.

The 1:25 models shift the scale to the scenographic, offering an intimate experience of two core moments in dramaturgy: the crossing (the bridge) and the pause (the resting place with memory frame). In these, materials are selected not only for fidelity but for narrative:

*Model 1:200*  
The landscape

*The model*

*The performance*

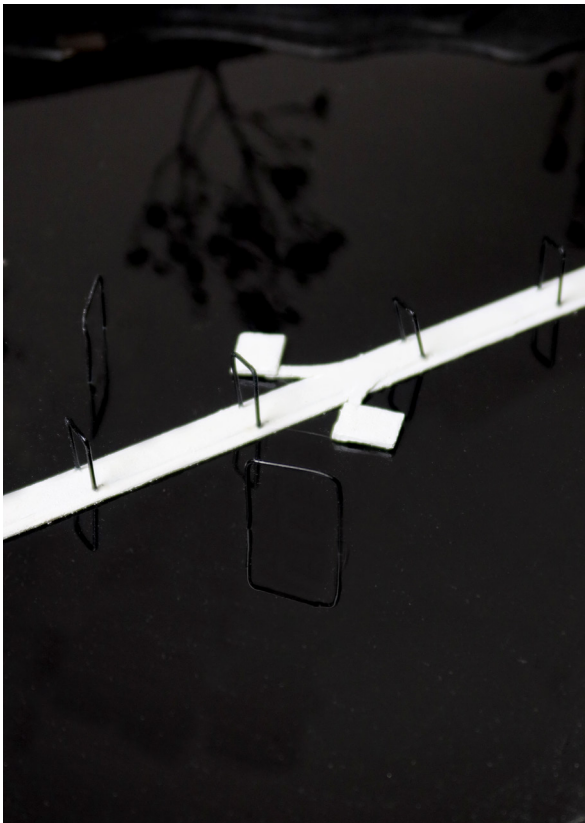



*ACT II - Model 1:25*

An emotional exploration of balance - between sinking and floating - captured through the concept of Via Media, the middle road. Real and translated materials merge: Bohus granite as microcement on paper, water as acrylic glass. The bridge frame in wood, veiled in shimmering fabric. Technically and atmospherically rhythmic - floating - revealing how the bridge carries its load through light, shadow, and intention.





*ACT III - Model 1:25*

An emotional reflection on how our past is never far - it surrounds and shapes us. Guided by the poem "Minne", wood supports a resting space that floats above the surface, the frame is veiled in beige mesh. Technically subtle yet evocative, the piece explores how memory projects itself - fleeting - in light, shadow, and silence.

*The model*

*The performance*

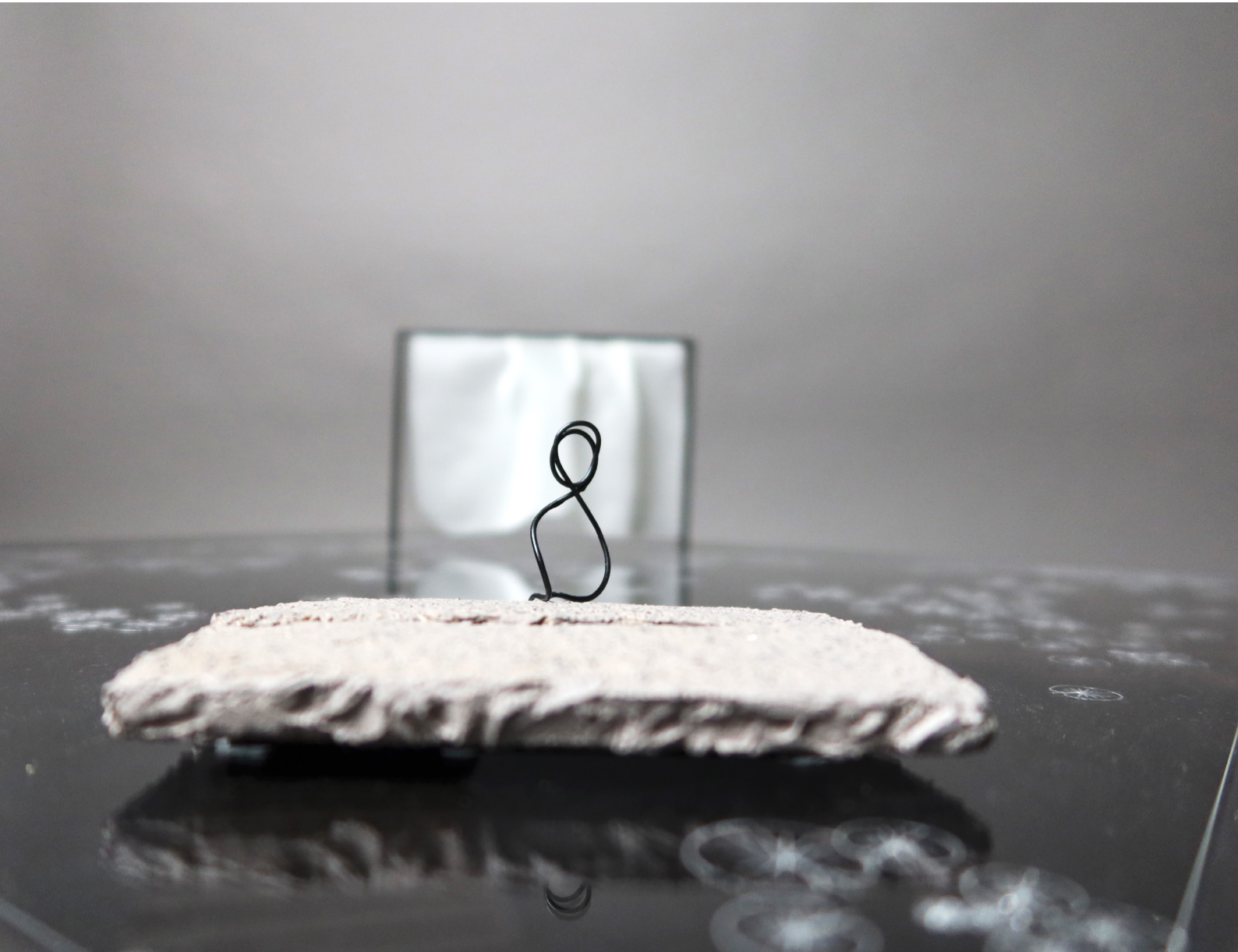



*The model*



*The performance*

*Model concept*

This model explores how memory can be framed, held, and re-experienced. A light fabric becomes the carrier of projected images - fragments of the past - hovering gently in space. The fabric does not merely receive the projection; it absorbs and re-shapes it, creating a softened echo of what once was.

The wooden frame defines the boundary between present and past. It does not constrain the memory but instead gives it a structure, a point of return. Standing before the frame, the viewer is positioned in an act of looking back - a constructed recollection shaped by light, material, and shadow.

This is not a static moment, but a fleeting one. The image shifts with the movement of the viewer, with the air, with time - just as memories do.



Ep

oil

*Epilogue*

## The final curtain

This thesis explores scenography as a spatial strategy to activate, engage and represent collective memory in public space. At its core is an inquiry into how poetic and performative tools can be integrated into architectural design without compromising either technical precision or emotional depth. Rather than treating scenography and architecture as distinct disciplines, this work frames them as co-authors of space: architecture offers structure and durability; scenography brings rhythm, emotion and narrative.

### Context and intent

The investigation was grounded in the design of a temporary installation at Näckrosdammen in Gothenburg - a site layered with both visible history and subtle stories. Rather than imposing a narrative, the project sought to respond to the site's existing atmosphere, using scenographic tools to draw out latent memories and emotional cues. The design was built around the spatial translation of three poems by Karin Boye, each forming an

act within a dramaturgical sequence. The aim was not to explain the site, but to resonate with it.

### Methodology and theoretical foundation

The thesis draws on Maurice Halbwach's theory of collective memory, which understands memory as a shared, dynamic construct shaped through space, ritual and repetition. This theoretical lens informed a design method that emphasized ephemeral, layered and subjective experiences rather than fixed monuments.

Scenographic tools such as spatial sequencing, rhythm, material dramaturgy and emotional pacing were not used merely for aesthetic purposes. Instead, they served as active strategies for spatial interpretation and storytelling. The process involved both intuitive and analytical approaches, allowing poetry and place to shape the architecture.

### A scenographic methodology

This project proposes a scenographic method that is both generative and interpretive. It can be used to design new spaces or read existing ones. Key elements of this method include:

- Spatial sequencing: Interpreting space as a series of narrative acts.
- Material symbolism: Selecting materials for their poetic and sensory qualities, not just performance.
- Emotional mapping: Designing with attention to atmosphere, memory and mood.

This methodology could be applied beyond this project - to uncover embedded narratives in public spaces or to inform emotionally resonant architectural interventions.





### **Framing the Site**

Näckrosdammen is a framed yet open space, defined by still water, soft typography and tree-lined edges. The design approach was not to overwrite the site, but to work with it - to add rhythm, not dominance. The installation slipped into the landscape as a sequence of gestures rather than objects: a bridge becomes a passage across memory; a crack in the stone becomes a portal to the past.

To me, Näckrosdammen already functioned as a theatre: the benches as seating, the trees as wings, the water as stage. What needed to be added was not a new place, but a new story. The scenographic lens allowed me to read the site as a living composition and contribute a subtle score to it.

### **Material as narrative**

Material decisions balanced technical requirements with symbolic resonance. Bohus granite was chosen for its civic strength, historical relevance and textual clarity. Bog oak, with its dark density and archaeological past was used beneath the granite - a buried memory only glimpsed through a fracture. The stone became grounding and rhythmic; the wood, hidden yet heavy, evoke the unspoken.

Reflective fabric on the bridge introduced the ephemeral - catching light and air like fleeting thoughts and youth - while the mem-

ory frames uses matte mesh that absorb projections and create a filtered presence. These materials were not neutral elements but narrative actors. They shaped mood, invited interpretation and choreographed attention.

### **Rhythm and sequence**

From an architectural standpoint, rhythm was a structuring device. The bridge was composed of interruptions - joints, levels, frames - that guided movement and pause. Water partially covering certain stones created moments of resistance, making the act of walking a form of performance.

Poetry informed spatial rhythm. Each poem translated into spatial conditions: entrance as hesitation, bridge as oscillation, resting place as pause. Visitors became performers, their movement part of the script. Architecture here provided the framework for scenographic storytelling.

### **Responsibility and design ethic**

Architecturally, the design prioritized buildability, dismantlement and environmental care. Materials were selected to endure without harming the site. Structurally, the installation respected the terrain and water. Poetically, every element served a purpose beyond function - to evoke, suggest and invite reflection.

Rather than permanence, the goal was presence: a moment of resonance rather than a

lasting statement. The project trusted the visitor to complete the experience through personal memory, association and emotional response.

### **Collective memory: Atmosphere over monument**

Collective memory in this project was not housed in a singular object or plaque. It was distributed through material, light, rhythm and absence. The decision to work temporarily and scenographically, rather than monumentally, was a conceptual stance: memory was allowed to shift, to appear and disappear.

In contrast to declarative works like Eisenman's Holocaust Memorial or the ambiguous programming of Tschumi's Parc de la Villette, this project centered the memory of the passer-by. It invited projection rather than instruction. It asked not what memory is, but how it might feel in space.

### **Scenography as spatial critique**

The scenographic approach developed here is not limited to design. It offers a mode of spatial critique that complements functional analysis with sensitivity to rhythm, emotion and atmosphere. To see space scenographically is to ask: Where does rhythm shift? Where does material invite pause or distance? What emotions are embedded in the structure?

Public spaces, entrances or even housing blocks can be read through this lens. A square becomes a stage of encounter. A corridor reveals a tension of approach. This approach uncovers latent dramaturgies and invites a more human reading of architecture.

### **Final Reflections**

This project has used scenography not just to shape space, but to shape attention. It has offered a method for listening to a site through silence, memory and rhythm. Näckrosdammen was never neutral; its history lingers in its stillness and form. The intervention sought not to overwrite that but join it gently.

The questions raised here - about memory, emotion and poetic architecture - are not closed. They open up a way of working where design becomes narrative and memory is not declared but discovered.

Ultimately, this thesis proposes that memory in public space need not be monumental to be powerful. It can shimmer, flicker and still endure.

# Bibliography

## Literature

Aristotle (384-322). *Poetics*. Trans. Richard Janko. Indianapolis: Hackett, 1987. Print.

Forty, A. (2000). *Words and buildings: A vocabulary of modern architecture*. Thames & Hudson.

Halbwachs, M. (1992). *On collective memory* (L. A. Coser, Ed. & Trans.). University of Chicago Press.

Howard, P. (2019). *What is scenography?* (3rd ed.). Routledge.

Jacobs, S. (2012). *Architecture as reenactment*. Strelka Press.

Saltzman, L. (2006). *Making memory matter: Strategies of remembrance in contemporary art*. University of Chicago Press.

Thessman, L.-Å. (2018). *Till rum blir tiden här*. Art and Theory.

## Online articles

Cattaneo, A. (2021). *The art of dramaturgy*. Yale University Press. <https://ebookcentral.proquest.com/lib/chalmers/detail.action?docID=6687700>

Gough, R., & Lotker, S. (2013). On scenography: Editorial. *Performance Research*, 18(3), 3-6. <https://doi.org/10.1080/13528165.2013.818306>

Pitches, J. (2012). Anonymity is the essence: In search of Adolphe Appia. *Theatre Research International*, 37(2), 134-149. <https://doi.org/10.1017/S0266464X12000243>

## Webpages

Adobe. (n.d.). *Color meaning: The psychology of color*. Adobe. <https://www.adobe.com/creativecloud/design/discover/color-meaning.html>

Föreningen FASAD. (2023, February 6). *Ansvarsutkrävande för rivningen av Flickläroverket - korrespondens med Akademiska Hus*. <https://foreningenfasad.se/inlagg/ansvarsutkravan->

de-for-rivningen-av-flicklaroverket-korrespondens-med-akademiska-hus/

Göteborgs Konsthall. (2019). *Bergsjöfamet - Saturnus Project*. <https://goteborgskonsthall.se/urban-konst/bergsjofamet-saturnus-project/>

Göteborgs Stad. (2018). *Göteborg - modig förebild inom arkitektur: Arkitekturpolicy för Göteborgs Stad*. <https://goteborg.se/wps/portal/start/byggande--lantmateri-och-planarbete/kommunens-planarbete/arkitekturpolicy>

Humlesjö, S., Åhlfeldt, J., Strinnholm, A., et al. (2023). *Göteborgs jubileum 1923* (v.1.0). GRIDH. <https://jubileet1923.dh.gu.se/>

Karin Boye Society. (n.d.). Timeline - Karin Boye's life. <https://www.karinboye.se/om/biografi/tidsaxel-en.shtml>

Scen & Film. (2025). *Ordlista - Scenografer & kostymdesigner*. <https://scenochfilm.se/yrkesavdelningar/scenografer-kostymdesigner/lathund/ordlista/>

Sveriges Radio. (2024, December 10). *Här rivs Snäckan – den klassiska macken i Majorna*. <https://www.sverigesradio.se/artikel/har-rivs-snackan-den-klassiska-macken-i-majorna>

## Images

Picture 1: Jubileumsutställningen 1923. (1923). *Utsikt från Fyrtornet, Jubileumsutställningen i Göteborg* [Photograph]. <https://jubileet1923.dh.gu.se/items/show/94>

Picture 2: Dalbéra, J.-P. (2010). *Monumenta 3, Christian Boltanski au Grand Palais à Paris* [Photograph]. Flickr.

Picture 3: Paulamarinm. (2016). *Stage set design by Adolphe Appia* (1 September 1862 – 29 February 1928) [Photograph]. Wikimedia Commons.

Picture 4: Thessman, L.-Å. (2011). *Scenographic sketch of Alcina* [Scenographic sketch]. Göteborgsoperan.

Picture 5: Victuallers. (2016). *Donmar Warehouse set design by Es Devlin at FutureFest* [Photograph]. Wikimedia Commons.

Picture 6: Wilschut, H. (2008). *Einstein on the Beach* [Photograph]. Wikimedia Commons.

Picture 8: Jubileumsutställningen 1923. (1923). *Minareterna, Jubileumsutställningen i Göteborg* [Photograph]. <https://jubileet1923.dh.gu.se/items/show/94>

Picture 10: Jubileumsutställningen 1923. (1923). *Minneshallen från Näckrosdammen, Jubileumsutställningen i Göteborg* [Photograph]. <https://jubileet1923.dh.gu.se/items/show/94>

Picture 12: Jubileumsutställningen 1923. (1923). *Idrottshallen, Jubileumsutställningen i Göteborg* [Photograph]. <https://jubileet1923.dh.gu.se/items/show/94>

Picture 14: Jubileumsutställningen 1923. (1923). *Näckrosdammen, Jubileumsutställningen i Göteborg* [Photograph]. <https://jubileet1923.dh.gu.se/items/show/94>

