

# CHALMERS

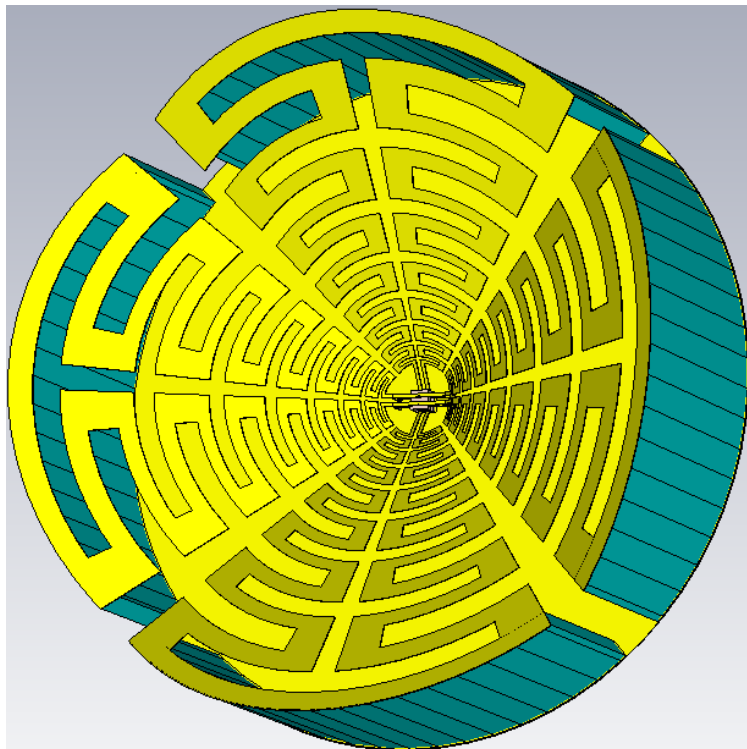

## **Design and optimization of Eleven feed over 300-2000 MHz**

Master of Science Thesis in Radio and Space Science

Yoness Maleki

Department of Signals & Systems

Antenna Group

Chalmers University of Technology

Göteborg, Sweden 2020

Master's Thesis 2020

## **Declaration**

"Hereby I certify to be the original author of this report and that it has been designed exclusively by me. In case external information or work has been used, e.g. in form of figures, equations and ideas by other people, this is cited and clearly documented in the text.

Signature: Yoness Maleki

# **Design and optimization of Eleven feed over 300-2000 MHz**

Master of Science Thesis

Yoness Maleki

Supervisors: Prof. Jian Yang

Examiner: Prof. Jian Yang

Keywords: eleven feed, 300-2000 MHz, Design and optimization

Series: ISSN 99-2747920-4; no EX065/2012.

Department of Signal and System  
CHALMERS UNIVERSITY OF TECHNOLOGY  
SE-41296 Göteborg, Sweden Telephone: +46 317721000

Göteborg, Sweden 2020

## **Preface**

This report is a master thesis, the project of which was carried out by master student Yoness Maleki at Antenna Division, Department of Signal and System, Chalmers University of Technology. The supervisor and the examiner was Prof. Jian Yang.

## **Acknowledgements**

I am grateful to Dr. Jian Yang for his comprehensive experience, knowledge and support in guiding me throughout the project. I have learnt a lot from him both practically and theoretically.

Yoness Maleki, Gothenburg, Sweden 2020

## **Abstract**

The ultra-wideband (UWB) radio telescopes need UWB feeds for reflector antennas to fulfil the important specifications of the future radio telescope projects, such as the Square Kilometer Array (SKA) and Very Long Baseline Interferometry (VLBI). In this thesis work, an Eleven feed antenna was designed by using Computer Simulation Technology (CST) program at 300-2000 MHz band frequency.

The Eleven feed antenna is a log-periodic folded-dipole pair array with a nearly constant beamwidth and a fixed phase center location over a decade bandwidth that have been developed by antenna group at Chalmers University of Technology. This project presents a new compact design of a 300–2000MHz Eleven feed antenna that might be used as feeds for reflector antennas. The Eleven feed has a compact geometry, high BOR1 efficiency in its far field function behaviour and wide bandwidth of performance. The high BOR1 efficiency is a significant characterization for the modern UWB feed technologies.

The Society and civilization Algorithm optimization schema has been used to achieve low reflection coefficient with a high efficiency. CST simulation has shown that the circular Eleven feed has a reflection coefficient below -12 dB over 300-2000 MHz.

## List of Figures

Figure 1: Square kilometer array (SKA) is a radio telescope system .....	10
Figure 2: Antenna as a part of communication system [4] .....	12
Figure 3: Wire Antenna Types [4] .....	13
Figure 4: Aperture Antenna Types [4].....	14
Figure 5: Microstrip Antenna Types [4] .....	14
Figure 6: Reflector Antenna Types [4] .....	15
Figure 7: Antenna Reciprocity [4] .....	18
Figure 8: Horn Antenna including, Dielectric losses, Conduction losses and Reflection coefficient [5] .....	19
Figure 9: Eleven Antenna Configuration .....	21
Figure 10: Modeling of Eleven Antennas [14] .....	22
Figure 11: Geometry Parameters of Eleven Antennas [16] .....	23
Figure 12: Geometry Parameters of Eleven Antennas (central part).....	24
Figure 13: (a) Clusters A, B, C, and D. (b) Individuals in every cluster immigrate toward their leaders. (c) Leaders of the clusters migrated to cluster B [21]. .....	25
Figure 14: Maximum reflection coefficient of dipole petals .....	26
Figure 15: Process of finding Best leader .....	27
Figure 16: Leaders of the clusters .....	28
Figure 17: Reflection Coefficient of Leaders .....	29
Figure 18: Best Leader.....	30
Figure 19: Impact of orthogonal dipole petal on the reflection coefficient.....	31

# Table of Content

Preface .....	4
Acknowledgements.....	5
Abstract.....	6
List of Figures .....	7
1 Introduction .....	10
1.1 Square Kilometer Array .....	10
1.2 Very Long Baseline Interferometry.....	11
1.3 Motivation .....	11
1.4 Outlines of Thesis Report .....	11
2 Antenna Fundamentals .....	12
2.1 Antenna Definition .....	12
2.2 Applications .....	13
2.3 Antenna Types .....	13
2.3.1 Wire antenna.....	13
2.3.2 Aperture antenna .....	14
2.3.3 Microstrip antenna.....	14
2.3.4 Reflector antenna.....	15
2.3.5 Lens antenna .....	15
2.4 Definitions and principles .....	15
2.4.1 Electromagnetic Fields .....	15
2.4.2 Field Region .....	16
2.5 Polarization.....	16
2.5.1 Linear polarization.....	16
2.5.2 Circular Polarization .....	17
2.6 Reciprocity.....	17
2.7 Radiation power and directive gain.....	18
2.8 Directivity .....	18
2.9 Antenna Gain and antenna efficiency .....	18
2.10 BOR1 Antenna .....	19
2.10.1 BOR1 efficiency .....	19
2.11 Spillover efficiency.....	20
2.12 Polarization efficiency .....	20
2.13 Illumination efficiency .....	20
2.14 Phase efficiency .....	20
3 Modeling .....	21
3.1 Eleven antennas Configuration .....	21
3.2 Modeling procedures in CST .....	22

3.3	Eleven Antenna Geometry Parameters .....	23
3.4	Electrical Design.....	24
4	Optimization.....	25
4.1	Social Civilization Algorithm .....	25
	References.....	33
	Appendix:Matlab Codes.....	34

# 1 Introduction

## 1.1 Square Kilometer Array

Square kilometer array (SKA) [1] is a radio telescope system which is developing in south hemisphere in South Africa and Australia for studies of the initial universe in fundamental physics, cosmology and space science. These locations are the best places in whole the world with lowest level of man-made radio interference for observing the Milky Way galaxy. The SKA radio telescope consists of thousand linked antennas with total collecting area of one square kilometer. The SKA will operate over wide band frequency that makes it fifty times more sensitive and will have more than ten thousand times of survey speed than the nowadays radio telescopes.

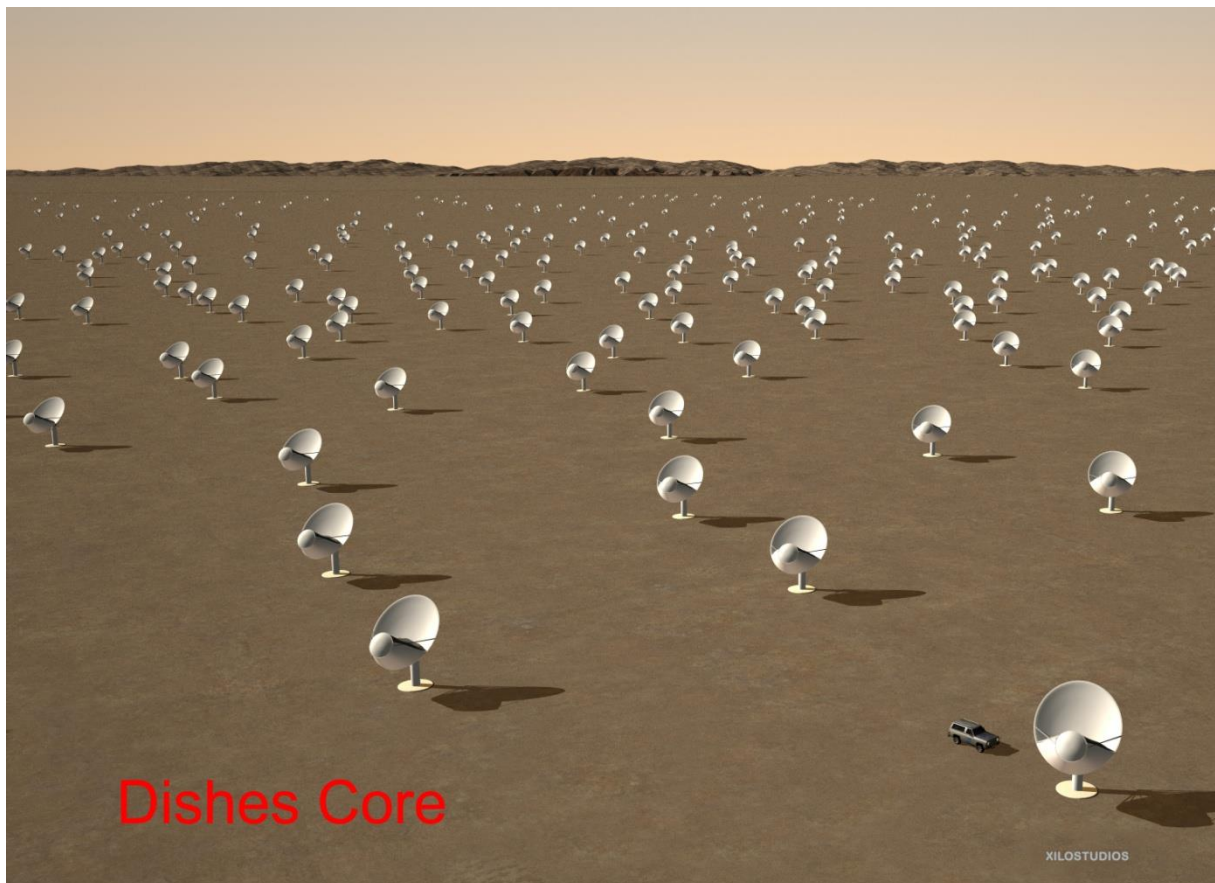

(XILOSTUDIOS), <http://commons.wikimedia.org/>)

**Figure 1: Square kilometer array (SKA) is a radio telescope system**

The SKA will combine receiving signals from all linked small antennas, which corresponds to a giant radio telescope antenna with very large field of view that enable several users to observe different parts of sky at the same time. The SKA will make a radio observation at the frequency range of 70 MHz to 10 GHz which could not be implemented by single antenna design therefore SKA will contain three sorts of antennas: SKA- low, SKA-mid and dish arrays. SKA-low array will cover the frequency range of 70 to 200 MHz, SKA-mid will cover the frequency range of 200 to 500 MHz and dish array will cover frequency range of 500 MHz to 10 GHz.

## **1.2 Very Long Baseline Interferometry**

Due to the weakness of receiving signal from astronomical sources, astronomical observation always demands large parabolic dish radio telescope antenna to increase resolution but the maximum size of the parabolic dish radio telescope is practically and financially limited. In order to obtain highest possible resolution, astronomers have developed a method of combining the signals from an array of several small radio telescope antennas which is called radio interferometry and the distance between every two antennas is called baseline.

The very long baseline interferometry is an array antenna consisting of ten radio telescopes far from each other that are monitored remotely by their array operation central in New Mexico. The VLBI covers the frequency range of 0.3 GHz to 96 GHz which contain all eight radio astronomy frequency bands. These ten radio antenna make the longest system that utilize the very long baseline interferometry. Each VLBI radio telescope antenna constructs of parabolic dish antenna with 25 meter in diameter that comprise low noise electronic, computer, data storage unit and the mechanical system to point out the antenna to different direction. The signals will be collected simultaneously from astronomical sources by different antenna. The distance between antennas is calculated by atomic clock and by using the time difference of receiving radio signal by each radio telescope. Observation of astronomical sources by VLBI system is corresponded to a radio telescope with a size of maximum distance between telescopes. All signal will be recorded and compare to each other to extract the resulting image. The image resolution is depended to observing frequency. The VLBI system has different applications such as spacecraft tracking, imaging distance of radio sources and astronomy, the VLBI system can even be used to map the movement of earth plate and earth rotation. [2]

## **1.3 Motivation**

The purpose of this thesis work is to design a compact solution to band 0.3–2GHz Eleven antenna. The design applies the social civilization algorithm in order to reduce the reflection coefficient.

Electromagnetic simulation and computation have been done by CST (computer simulation technology). The reflection coefficient ( $S_{11}$ ,  $S_{22}$ ) and mutual coupling is required to be less than -12 dB along the operating frequency band. The other requirements are low cross polarization and high aperture efficiency over the operating frequency band. The complete design specifications for the thesis work are detailed in Chapter 3.

## **1.4 Outlines of Thesis Report**

This thesis is organized in the following 4 chapters,

Chapter 1 presents the possible global projects that may use Eleven feed antenna. It also gives motivation and outlines of the project work.

In chapter 2, the antenna basics and important definitions and principles are briefly described. Different antenna topologies, antenna parameters, significant definition and principle in antenna theory are discussed.

Chapter 3 gives a summary of the Eleven antenna configuration design and the schematic design and simulation in CST. It also explains the Eleven Antenna Geometry Parameters and electrical design of Eleven antenna.

Chapter 4 discusses the tuning and optimization methods. Optimization analysis using Genetic Algorithm method is discussed which is widely applied in optimization of different antennas. The Social Civilizations algorithm will be present as optimizations method in this thesis work. Simulation results of CST simulation are presented for different cases.

## 2 Antenna Fundamentals

### 2.1 Antenna Definition

Antenna can be defined in the different way but usually define as metallic unit to transmit and receiving electromagnetic waves or in the other word an antenna is a transducer between a transmission line and free space. A transmission line or guiding device could be in a form of waveguide or coaxial cable that its function is to carry electromagnetic energy from antenna to the receiver or from transmitter to the antenna.

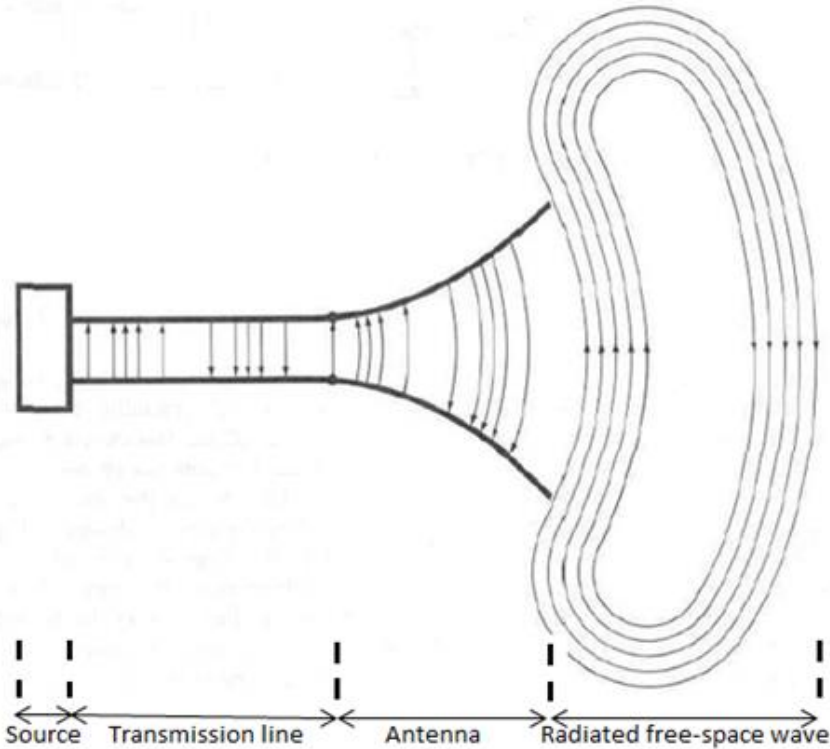

Figure 2: Antenna as a part of communication system [4]

Moreover, an antenna in communication system needs to optimize the radiation energy in its band frequency and specific direction and suppress in other frequency and direction (In the case of point to point or line of sight (LOS) antenna) that make an antenna a frequency selective filter and directional spatial.

An antenna is last component in the transmitter part and the first component in receiver part of communication system which transfer and receive signal, therefore the antenna characteristics and antenna design play a critical role in the communication system performance.

### 2.2 Applications

Antennas have been used in ground-based telecommunication systems such as Broadcasting, radio links, mobile phone, base station and navigation system. They have also been utilized in civilian and military radar systems like weather radar, air traffic control radar, satellite communication systems, surveillance and military radar. Antennas are used in radiometers like radio astronomy, meteorology and military early warning system.

### 2.3 Antenna Types

Antenna can be classified in different manner. They can be classifying by their shape and sizes or their radiation pattern. Some of them are wide band and some are narrow band antenna, which are required and used in different application such as wire antenna, aperture antenna, microstrip antenna, array antenna, reflector antennas, lens antenna, slot antenna, horn antenna and so on. The ones that will be treated in this master thesis is Eleven antenna.

#### 2.3.1 Wire antenna

Wire antenna are most common antenna that is seen virtually everywhere on different device such as car, building, ship, aircraft, radio, TV and router. There are several different shapes of wire antennas such as dipole, helix and loop antenna which has different configuration such as rectangular, square, ellipse and circular.

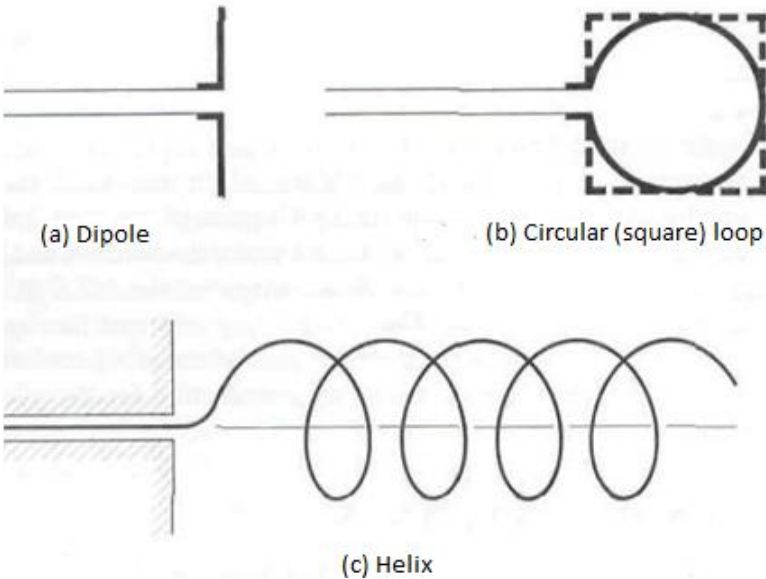

Figure 3: Wire Antenna Types [4]

### 2.3.2 Aperture antenna

Aperture antenna is more in used in the current-day than in the past due to this fact that the nowadays communication system requires more complex form of antenna design and communicating in higher frequency than in the past. This kind of antennas can be easily mounted on the surface of aircraft or spacecraft and can be covered by dielectric material to protect them from dangerous environmental condition. There are various configuration of aperture antenna such as pyramidal horn, conical horn and rectangular waveguide.

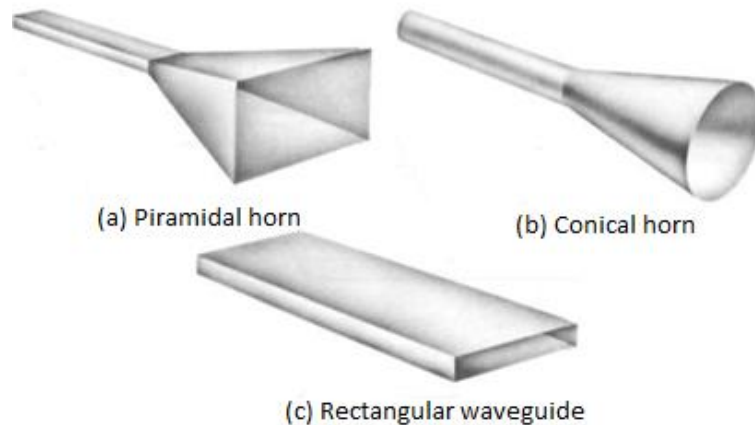

Figure 4: Aperture Antenna Types [4]

### 2.3.3 Microstrip antenna

Microstrip antennas are most utilized in commercial application. These antennas construct of metallic patch on a grounded substrate. The metallic patch can have different shape like rectangular and circular that are most regular among microstrip antenna. These types of antennas are easy and cheap to fabricate by using print circuit technology which make them more compatible for MMIC design. Their radiation features make them convenient for analysis. The microstrip antennas have very low cross polarization radiation and stable structure for mounting on hard surfaces such as aircraft, satellite, car and mobile phone.

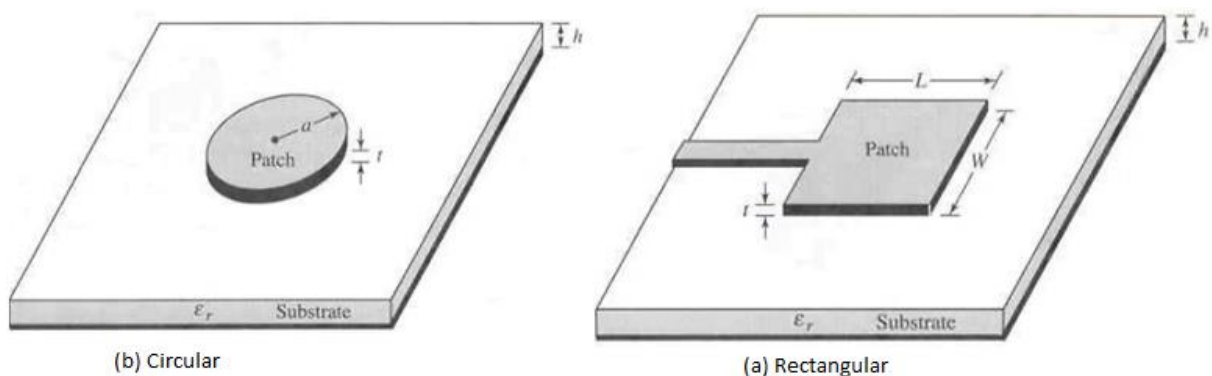

Figure 5: Microstrip Antenna Types [4]

### 2.3.4 Reflector antenna

Investigation in space requires more advance and sophisticated of antenna design which can create the opportunity of communication over far distance. The most frequent type of antenna that is in used in such an application is parabolic and corner reflector antenna. This kind of antenna have very large diameter to be able to transmit and receive signals for very long distance (mostly million of kilometre).

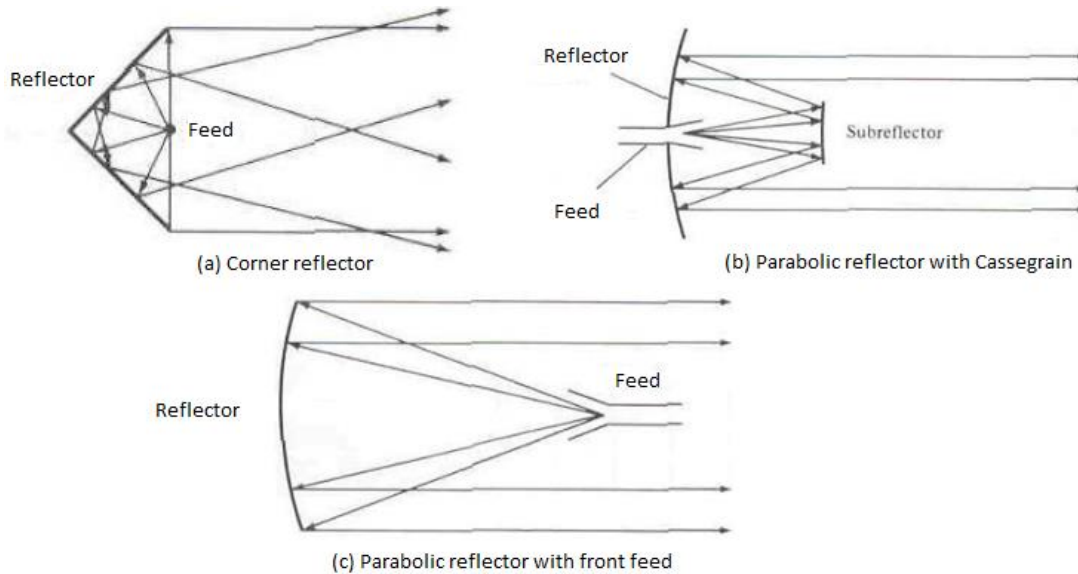

Figure 6: Reflector Antenna Types [4]

### 2.3.5 Lens antenna

Lens antennas are mainly utilized to orient the divergent electromagnetic wave to the desire direction. By selecting a suitable shape and material of lenses the divergent electromagnetic energy can be transform to the plane waves. The most application area of lenses antenna is the same as parabolic reflector antenna in high frequency range.

## 2.4 Definitions and principles

### 2.4.1 Electromagnetic Fields

The main important concept in electromagnetic theory is that the electric and magnetic field are always depended except for special case of zero frequency in the other word the time variation of electric's field create magnetic field and vice versa the time variation of magnetic field create electric field. Generally a current with some specific frequency are able to create electromagnetic field.

## 2.4.2 Field Region

Radiation field is basically wave's propagation away from antenna in the spherical form or radial direction in such a way that the waves far away from antenna can be considered as plane waves. Generally the field region can be divided to two regions, radiating far-field (Fraunhofer,  $R = 2D^2/\lambda$ ) region and radiating near-field region (Fresnel,  $R = 0.62\sqrt{D^3/\lambda}$ ). Where D is the smallest diameter of the sphere that includes whole antenna structure when it is located in free space and  $\lambda$  is the wavelength of electromagnetic wave propagation.

We can generally write the far field function at a point r in spherical coordinate system as:

$$E_r = \frac{1}{r} e^{-jkr} G(\theta, \varphi)$$

Where  $1/r$  is divergence factor,  $G(r)$  is the far field function and the  $e^{-jkr}$  is the phase factor

Which the  $\varphi$  variation can be expanded by Fourier series due to this fact that the  $\varphi$  variation is periodic with period of  $2\pi$  therefore we can rewrite the far field function in this way:

$$G(\theta, \varphi) = G_\theta(\theta, \varphi)\hat{\theta} + G_\varphi(\theta, \varphi)\hat{\varphi} = \sum_{n=0}^{\infty} [A_n(\theta) \sin n\varphi + B_n(\theta) \cos n\varphi] \hat{\theta} + \sum_{n=0}^{\infty} [C_n(\theta) \cos(n\varphi) - D_n(\theta) \sin(n\varphi)] \hat{\varphi}$$

## 2.5 Polarization

### 2.5.1 Linear polarization

At the distance far away from antenna, which the waves normally propagate as plane waves, the time harmonic E-field and H-field of a plane wave propagating in positive z-direction in free space can be shown by following equation [6]:

$$E = E_t e^{-jkz} = (E_x \hat{x} + E_y \hat{y}) e^{-jkz}$$
$$H = \frac{1}{\eta} \hat{z} \times E = \frac{1}{\eta} \hat{z} \times E_t e^{-jkz} = \frac{1}{\eta} (-E_y \hat{x} + E_x \hat{y}) e^{-jkz}$$

Where  $\eta = 377$  Ohms is the wave impedance in free space,  $k=2\pi/\lambda$ .

From above equations it can be easily seen that the electric and magnetic field have both x and y component respectively which means that the electromagnetic wave is polarized. This feature of

plane waves makes this opportunity to modulate different signal on each x and y component at the same frequency which means double the capacity of communication system. Generally, we can double the capacity by making use of any pair of orthogonal polarization. For this purpose, both transmit and receive antennas must be designed in a good way to identify different polarization. Such a requirement is formulated by identify one of the polarizations as desired (co-polar) polarization and the other as undesired polarization (cross-polar).

The polarization is always defined and specified by features of electric field and can be shown concerning a desire co-polar and cross-polar component:

$$\vec{E} = (E_{co}\hat{c}\hat{o} + E_{xp}\hat{x}\hat{p})e^{-jkz}$$

Which generally an arbitrary linear polarization can be defined by as follow:

$$\hat{c}\hat{o} = \cos \xi \hat{x} + \sin \xi \hat{y}$$

$$\hat{x}\hat{p} = \sin \xi \hat{x} + \cos \xi \hat{y}$$

### 2.5.2 Circular Polarization

If the E-field rotates an angel  $2\pi$  by a period of time T a right hand or left-hand circular polarization can be created, which can simply define as below:

$$\hat{c}\hat{o} = (\hat{x} + j\hat{y})/\sqrt{2}$$

$$\hat{x}\hat{p} = (\hat{x} - j\hat{y})/\sqrt{2}$$

### 2.6 Reciprocity

One of the wave theory principle is reciprocity that justify this fact which each transmit antenna can be treated as receive antenna or in the other word every electromagnetic field analysis that is used to determine the transmit antenna characteristic are applicable for receive antenna. In the circuit theory reciprocity is the relation between currents and voltages, which state that if a current source at a port of antenna A causes a voltage measured at port B of other antenna which is placed at far away of antenna A and then if we excite antenna B with same current which we have exited antenna A we will measured the same voltage at port of antenna A that we have measured at antenna B at beginning [4].

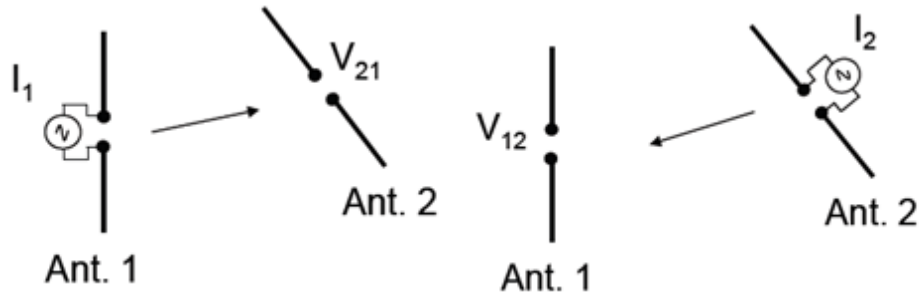

Figure 7: Antenna Reciprocity [4]

Which we can write  $\frac{V_{21}}{I_1} = \frac{V_{12}}{I_2}$

## 2.7 Radiation power and directive gain

The total isotropic radiated power is the integral of the radiation intensity over the entire far field sphere:

$$P_{rad} = \iint U(\theta, \varphi) \sin \theta d\theta d\varphi = \frac{1}{2\eta} \iint (|G_{co}(\theta, \varphi)|^2 + |G_{xp}(\theta, \varphi)|^2) \sin \theta d\theta d\varphi$$

The ratio of the radiation intensity to the radiation intensity of a reference antenna is called directive gain:

$$D_g = \frac{U(\theta, \varphi)}{U_{ref}} = \frac{4\pi U(\theta, \varphi)}{P_{rad}}$$

## 2.8 Directivity

The value of the directive gain in the direction of maximum value is called directivity

$$D_g = \frac{U_{Max}}{U_{ref}} = \frac{4\pi U_{Max}}{P_{rad}}$$

## 2.9 Antenna Gain and antenna efficiency

Antenna gain and directivity have almost same definition except that the total radiated power is replaced by total delivered power to the antenna port.

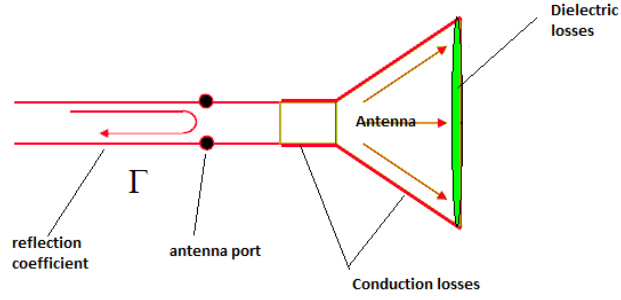

Figure 8: Horn Antenna including, Dielectric losses, Conduction losses and Reflection coefficient [5]

$$G_0 = e_{total} D_0$$

$$e_{total} = e_r e_{ohmic} e_{ap}$$

Where  $e_{total}$  is the total antenna efficiency, the total antenna efficiency consist of three sub-efficiencies which represent by ohmic efficiency, reflection efficiency and aperture efficiency that the ohmic efficiency consists of conductor and dielectric efficiency in antenna material (see Fig.5) and near-in object such as user head.

The aperture efficiency can be further factorized to five other sub-efficiencies which give by the following formula [4]:

$$e_{ap} = e_{BOR1} e_{ill} e_{sp} e_{pol} e_{\varphi}$$

## 2.10 BOR1 Antenna

The structures of many antennas are rotationally symmetric or body of revolution but not necessarily their far field functions. If a body of revolution (BOR) antenna be excited by a short current on its symmetry axis the radiation field will only contain the  $n=1$  terms of the expansion, so the far field function becomes [4]:

$$G(\theta, \varphi) = G_{\theta 1}(\theta, \varphi) \hat{\theta} + G_{\varphi 1}(\theta, \varphi) \hat{\varphi} = [A_1(\theta) \sin \varphi + B_1(\theta) \cos \varphi] \hat{\theta} + [C_1(\theta) \cos \varphi + D_1(\theta) \sin \varphi] \hat{\varphi}$$

### 2.10.1 BOR1 efficiency

The BOR1 efficiency can be calculated by following formula [4]:

$$e_{BOR1} = \frac{\int_0^{2\pi} \int_0^{\pi} \left[ |G_{\theta 1}(\theta, \varphi)|^2 + |G_{\varphi 1}(\theta, \varphi)|^2 \right] \sin \theta d\theta d\varphi}{\int_0^{2\pi} \int_0^{\pi} \left[ |G_{\theta}(\theta, \varphi)|^2 + |G_{\varphi}(\theta, \varphi)|^2 \right] \sin \theta d\theta d\varphi}$$

In order to calculate the other subefficiency the feed is assumed to be BOR1 type, so we can use the co-polar and cross-polar far field function resulting from the BOR1 in the  $\phi=45^\circ$  plane.

$$G_{co45}(\theta) = \frac{1}{2} [G_E(\theta) + G_H(\theta)] \quad ,$$

$$G_{xp45}(\theta) = \frac{1}{2} [G_E(\theta) - G_H(\theta)]$$

### 2.11 Spillover efficiency

Spillover efficiency represents the power hitting the main reflector or the power within the subtended angle  $\theta_0$  relative to the total power radiated by feed. The spillover efficiency can be calculated by [4]:

$$e_{sp} = \frac{\int_0^{\theta_0} [ |G_{co45}(\theta)|^2 + |G_{xp45}(\theta)|^2 ] \sin \theta d\theta}{\int_0^\pi [ |G_{co45}(\theta)|^2 + |G_{xp45}(\theta)|^2 ] \sin \theta d\theta}$$

### 2.12 Polarization efficiency

The power of the co-polar respect to the total power within the subtended angle  $\theta_0$  it is given by [4]:

$$e_{pol} = \frac{\int_0^{\theta_0} [ |G_{co45}(\theta)|^2 ] \sin \theta d\theta}{\int_0^{\theta_0} [ |G_{co45}(\theta)|^2 + |G_{xp45}(\theta)|^2 ] \sin \theta d\theta}$$

### 2.13 Illumination efficiency

The illumination efficiency is a measure of the non-uniformity of the field across the aperture caused by the tapered radiation pattern that is given by [4]:

$$e_{ill} = 2 \cot^2 \left( \frac{\theta_0}{2} \right) \frac{\int_0^{\theta_0} [ G_{co45}(\theta) \tan \left( \frac{\theta}{2} \right) d\theta ]}{\int_0^{\theta_0} [ |G_{co45}(\theta)|^2 \sin \theta d\theta ]}$$

### 2.14 Phase efficiency

The phase efficiency is caused by the location of phase reference point of the feed respect to the focal point of reflector which is given by [4]:

$$e_\varphi = \frac{\left| \int_0^{\theta_0} G_{co45}(\theta) \tan \left( \frac{\theta}{2} \right) d\theta \right|^2}{\left[ \int_0^{\theta_0} |G_{co45}(\theta) \tan \left( \frac{\theta}{2} \right) d\theta \right]^2}$$

### 3 Modeling

#### 3.1 Eleven antennas Configuration

The Eleven feed antenna is a log-periodic folded-dipole pair array with a nearly constant beam width and a fixed phase center located over a decade bandwidth. This type of antennas has been developed at Chalmers University of Technology [7]-[16]. The properties of the Eleven antenna make it one of the best alternatives among the other broad bandwidth antennas to be used as a feed in parabolic antenna for the SKA [1] and VLBA [2] projects. In addition to radio telescopes applications, the Eleven antenna can be used in other areas, such as, satellite communication terminals and as monitoring antennas in satellite communication systems [17]. This section describes the eleven antennas configuration and how to model it in Computer Simulation Technology programme (CST) [18].

In fact, the elementary geometry of the Eleven antenna is two parallel folded dipoles, located above a ground plane and separated by half a wavelength of each other. Then the couple of folded dipoles are produced with a log-periodic scaling factor to the required numbers, to build two opposing log-periodic dipole arrays, which are called petals. In order to get better BOR1 efficiency of the Eleven feed, the geometry of four resemble petals folded dipoles of the dual polarized Eleven antenna have been design and constructed more rotationally symmetrical which is illustrated in Figure 9 [16].

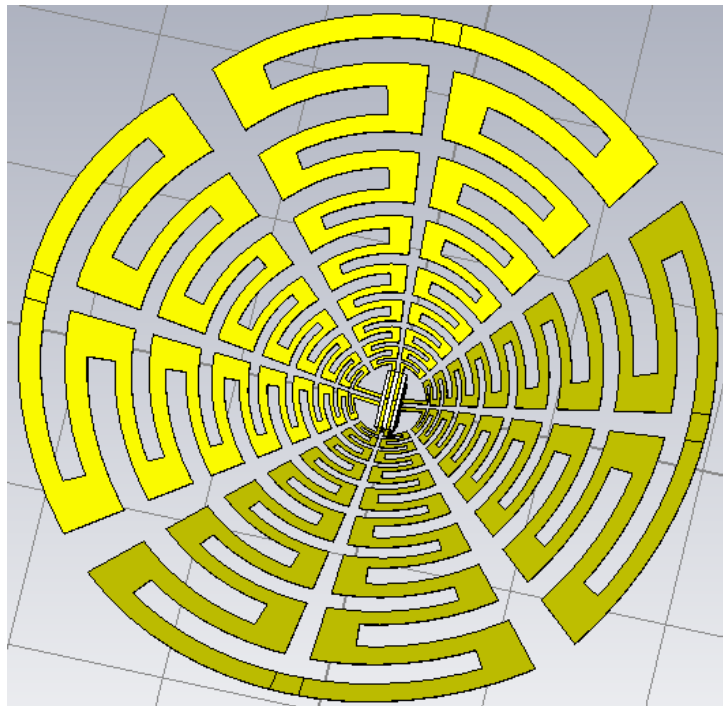

Figure 9: Eleven Antenna Configuration

### 3.2 Modeling procedures in CST

Based on the Eleven antenna symmetric shape, we just need to model the only half of one petal of the circular Eleven feed, and then complete the four petals of the feed by mirroring the structure relative to the two symmetry planes, x-z and y-z planes.

First of all we have to make a right-angle triangular metal plate (copper) of 1mm thick in CST, which is lying in x-y plane and the apex point of the angle  $\alpha_1$  is located at the origin of the coordinate system. Then the triangle plate is tilted with an angle  $\alpha_0$  relative to x-y plane, as shown in Figure 10a. In the next step triangle plate will

be trimmed by an auxiliary brick that is located in the x-y plane and rotate by angle  $\alpha_2$  respect to z-axis. By

this method the central-gap between the two symmetrical arms of the folded dipole is created.

In the next step, a sequence of auxiliary cylinders with different diameters and the same axis aligned in the z direction are constructed with log-periodic scaling factor. By intersecting the sequence auxiliary cylinders and tilted triangle metal plate and removing the intersection part the petal or folded dipole plate will be created. The Figure 10b and Figure 10c Shows the process how to use series auxiliary cylinder to make a circular inter-gap between consecutive folded dipoles and inner-gap between the arms of a folded dipole [16].

Due to use of auxiliary cylinder the folded dipole antenna looks circular when looking at the above view, or it has a circular projection on x-y plane, which makes its shape more rotationally symmetrical. However, it is not actually exactly circular on the triangle metal plate so we refer it to these quasi-circular folded dipoles.

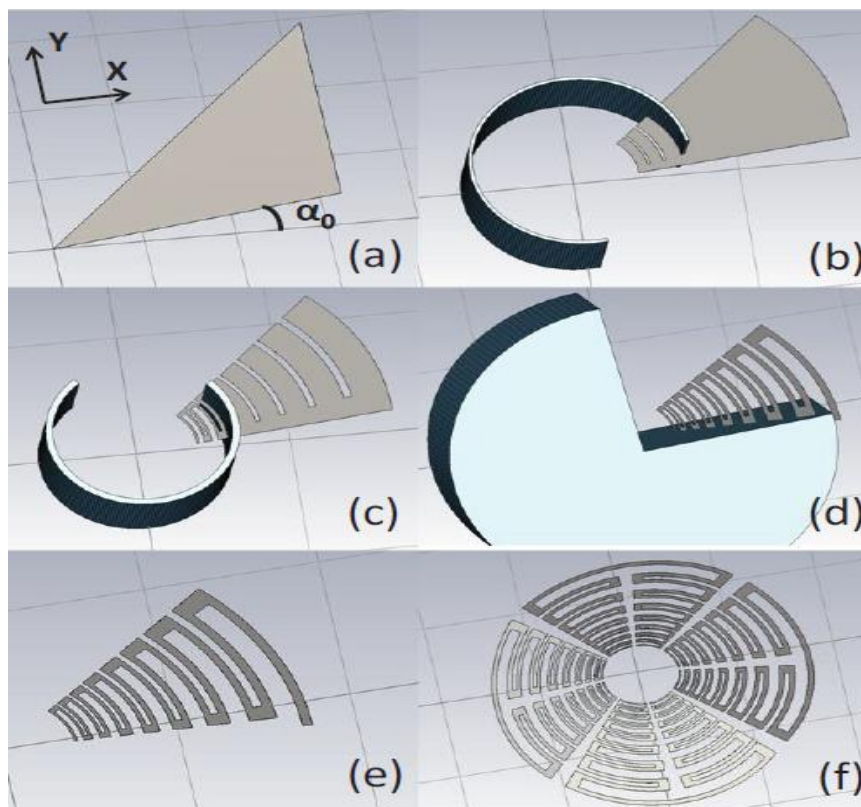

Figure 10: Modeling of Eleven Antennas [14]

### 3.3 Eleven Antenna Geometry Parameters

As it has been mentioned in the previous section the antenna geometry of the circular Eleven feed is built of four log-periodic folded dipole arrays antenna petals. Five independent Parameters can determine the whole petals geometry, the radius  $r_1$  of an auxiliary cylinder to make the inner curvature of first folded dipole,  $s_1$  to make the outer curvature by  $r_1+s_1$ ,  $w_1$  to determine the width of the first folded dipole arms, the angle  $\alpha_3$  to determine the length of inner and outer curvatures and at the end the scaling factor of the log-periodic array or  $k$  value to determine the rest dipoles parameters by [16]:

$$\begin{aligned} r_n &= r_1 \cdot k^{n-1}, & w_n &= w_1 \cdot k^{n-1} \\ s_n &= s_1 \cdot k^{n-1} & n &= 2, \dots, N \end{aligned}$$

It is shown in Figure 11 that all parameters except angles ( $\alpha_1, \alpha_2, \alpha_3$ ) are the measures of the projections of the folded dipole parameters on x-y plane, which makes the modelling in CST very simple.

The length of the first folded dipole  $L_1$  can be calculated by:

$$L_1 = \left( r_1 + \frac{s_1}{2} \right) \cdot \int_{-\alpha_1}^{\alpha_1} \sqrt{1 + \tan^2 \alpha_0 \sin^2 \varphi} d\varphi$$

And the length of dipole  $n$  is defined by  $L_n = L_1 \cdot k^{n-1}$ , where  $k$  is the scaling factor of the log-periodic array. It should be mention here that the four angles  $\alpha_0, \alpha_1, \alpha_2$  and  $\alpha_3$  are constant value in whole design procedure.

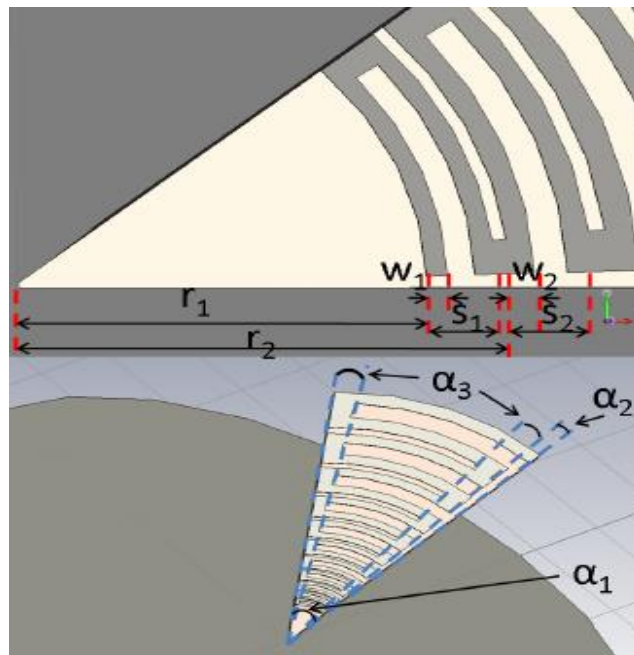

Figure 11: Geometry Parameters of Eleven Antennas [16]

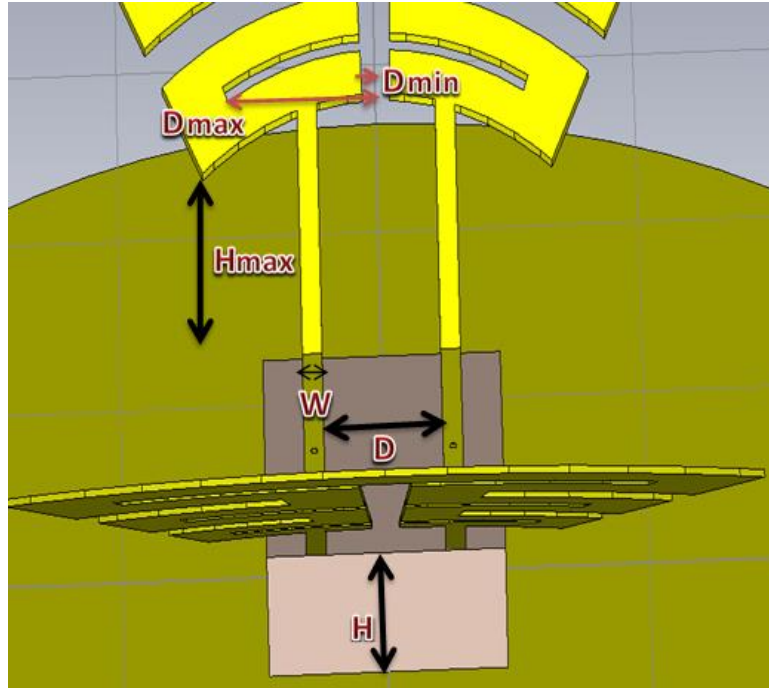

Figure 12: Geometry Parameters of Eleven Antennas (central part)

Three other parameters can be determined by the center puck of eleven feed antenna which have been depicted in Figure 12.

The distance between the two symmetrical arms of the folded dipole antenna is defined by parameter  $D$  likewise the width of copper connector is defined by parameter  $W$ . The height of the Teflon substrate which the folded dipoles or petals will be located on is specified by parameter  $H$ . All parameters have gone through the optimization in order to meet requirements while generating a suitable antenna structure.

### 3.4 Electrical Design

The aim of the electric design of the present Eleven antennas is to find the optimal case, which means to minimize the reflection coefficient at the input port of the antenna, and at the same time to have a good radiation pattern, between 300 and 2000 MHz

An analytic or quasi-analytic solution of the radiation field function of basic geometry of the Eleven antenna in [15], which is a pair folded dipole above an infinite ground plane, can give us an insight into how the Eleven antenna operates. This analysis will provide the information about the optimum dimension of each radiating dipole pair in specific frequency, the best radiation pattern shape and the advantages of folded dipole antenna compared to the normal dipole antenna with single-wire arms. However, there is no analytical formulation for the impedance and the far field function of log-periodic folded dipole array of the Eleven antenna

As matter of this fact, we have to determine the optimal dipole petal geometries for low input reflection coefficient by using numerical analysis with general electromagnetic solver. In the present design we applied the so-called social civilization algorithm to perform the optimization.

## 4 Optimization

As it has already been mentioned the optimization is to find the best possible solution

under certain constraints. One of the most essential desires in our world is the seeking for an optimal state. This fundamental concept is even observable in the microcosm where atoms in physical structure try to form bonds in order to minimize the energy of their electrons. During the process of freezing which molecules build solid crystal, they make effort to assume energy-optimal crystal structures. From past up to the present time, humankind have tried for perfection in many areas. We want to reach greatest possible of pleasure and happiness with the minimum attempt.

In our business, gain and sales have to be maximized and costs should be minimized as much as possible. Thus, optimization is one of the main issues which people even face in daily life. By considering some criteria, optimization is the selection of the best case from some set of available alternatives. In the most prevalent cases, the problem of optimization is maximizing or minimizing a function by selecting input values from an allowed set [20].

### 4.1 Social Civilization Algorithm

The social civilization algorithm is one of the numerical optimization methods which are been utilized successfully to the different of scientific and engineering problems. The possibility of an individual to the mutually interact is a basic social behaviour, which is more common in all human and insect societies. These social interactions will enable individuals to adjust and improve often faster than biological evolution that is just based on genetic inheritance. The exchange information in society outcomes in the immigration or colonization of the points toward a better performing point in the cluster that is similar to an intensified local search around a better performing point.

On the other hand, the leaders of societies will be improved also by exchanging information between societies, i.e., immigration from one society to another society. The phenomenon of leader immigration may contribute a better performing society to expand and grow that corresponds to a search around globally promising regions in the parametric space [20][21].

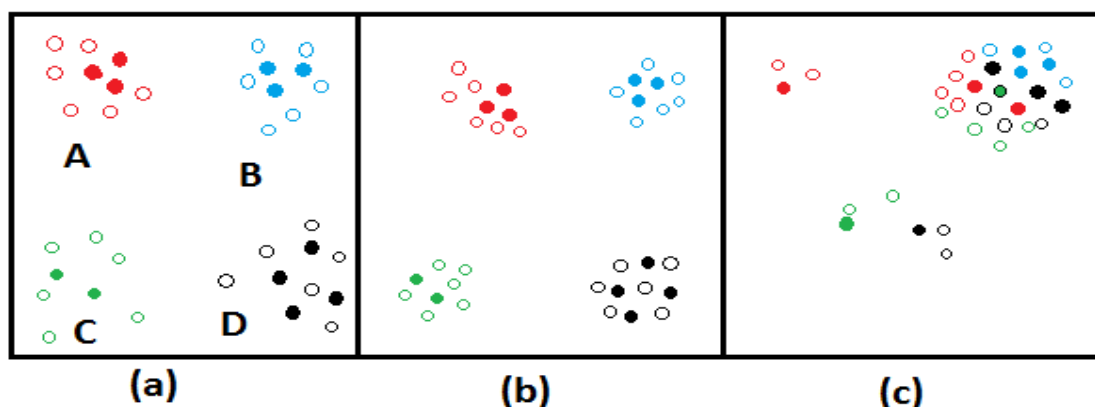

Figure 13: (a) Clusters A, B, C, and D. (b) Individuals in every cluster immigrate toward their leaders. (c) Leaders of the clusters migrated to cluster B [21].

Figure 13(a) illustrates the societies A, B, C, and D that constitute the civilization at the first moment. These individuals are grouped to constitute societies A, B, C, and D based on the parametric space. The leaders in each group of the societies are distinguished by using fill dot, while an average individual is shown with hollow dot. Figure 13(b) illustrates the movement or immigration of individuals of each cluster toward the best performing point or their leaders. Figure 13(c) indicates the state of the leaders in the civilization, where leaders of A, C, and D immigrate toward the better-performing leaders of society B. Those individuals in this project are randomly created dipole petals and the societies or colonies are those antennas which have almost similar shapes. This method is used to build up a low-frequency version of Eleven feed in this project in order to design the mechanical structure and optimize the center feeding, antenna petal and the termination of Eleven antennas for reducing the return loss and mutual coupling. The optimization started by analyzing only two opposing dipole petals. An arbitrary dipole petal can be produced through random genes, and then be approved by mechanical feasibility checking. The radiation performance of the feed will be evaluated by the values of the feed efficiency. As it is mentioned above one of the purposes of the optimization is to find out the reflection coefficient of the optimized linearly polarized Eleven antenna, as simulated by CST Microwave Studio, almost below -12dB over 300–2000 MHz when referred to an input balanced port impedance of coaxial cable (50 ohm )on both dipole petals. The optimization algorithms process has been coded by using MATLAB scripts. We have produced parameters randomly by Matlab and created different dipole petal. Maximum reflection coefficient of all cases has been checked over the band frequency through Matlab to see which one has almost fulfilled the requirement (Reflection coefficient of -12dB over band frequency). The process has been shown in Fig (12) for fifty cases. The case 23 and 49 are most suitable cases which are leaders in this society because they have the best performance in term of reflection coefficient.

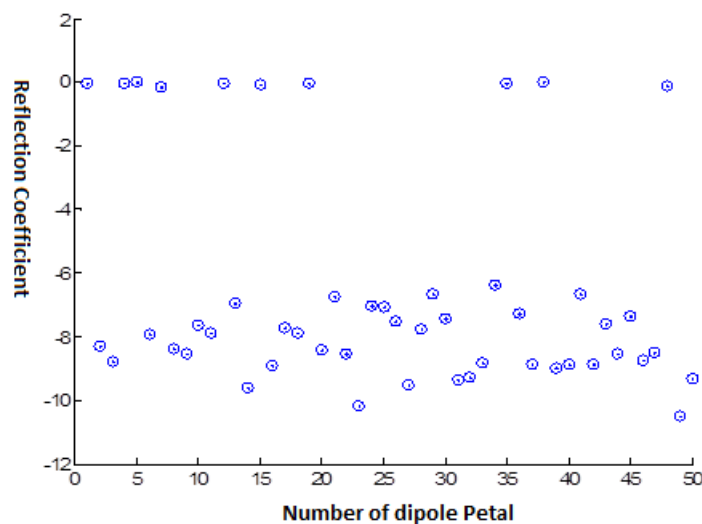

Figure 14: Maximum reflection coefficient of dipole petals

The simulation has been done for almost more than 500 cases by CST Microwave Studio that is very time consuming, to be able to overcome this particular problem we have to limit the number of dipole. By decreasing the number of dipoles to five dipoles, we can reduce simulation time to one quarter. Five societies have been selected which have almost reflection coefficient of -12dB over band frequency. (The band frequency is scaled for high frequency to  $(\frac{2}{k^4})$  because of decreasing of

the number of dipoles to five dipole). Table 1 shows geometry parameters of the leader of the five societies.

Colonies	H (mm)	W (mm)	D (mm)	R1 (mm)	W1 (mm)	S1 (mm)	K	$\alpha_0^\circ$	$\alpha_1^\circ$	$\alpha_2^\circ$	$\alpha_3^\circ$
1 <sup>th</sup> Col	10.66	3.71	12.32	37.50	2.39	7.45	1.33	35.97	39.74	2.57	5.77
2 <sup>th</sup> Col	13.46	3.78	6.03	37.50	1.68	3.82	1.31	36.41	37.59	1.14	2.92
3 <sup>th</sup> Col	10.87	2.18	14.30	37.50	2.62	11.32	1.32	35.31	44.29	4.39	10.03
4 <sup>th</sup> Col	13.84	2.80	16.58	37.50	4.58	10.39	1.32	38.04	36.24	2.91	1.28
5 <sup>th</sup> Col	10.46	3.14	10.98	37.50	0.91	7.76	1.29	35.82	37.60	3.66	1.62

**Table 1: Five Society's Leader Parameters**

As we can see from Fig (14a-e) and Fig (15a-e) the leader of the second society has the best shape and lowest reflection coefficient over band frequency. By respecting to the social civilization algorithm theory, the most leaders will immigrate from one society to another society that is managed by better performing leaders. Therefore, if we investigate inside this society we might find out the leader which has the best performance.

In order to find the best leader, we have to change the parameters of the second society leader by a constant radius and check other leader which is distributed around this leader. The process has been illustrated in Figure 15. The best leader has been discovered in second generation (see Fig.16) with following parameters in table 2 which has very good shape and almost -15dB reflection coefficient over band frequency.

Generation	H (mm)	W (mm)	D (mm)	R1 (mm)	W1 (mm)	S1 (mm)	K	$\alpha_0^\circ$	$\alpha_1^\circ$	$\alpha_2^\circ$	$\alpha_3^\circ$
2 <sup>th</sup> Gen	6.63	3.74	4.85	37.50	2.70	8.36	1.34	33.46	41.19	2.42	8.07

**Table 2: Best Leader Parameters**

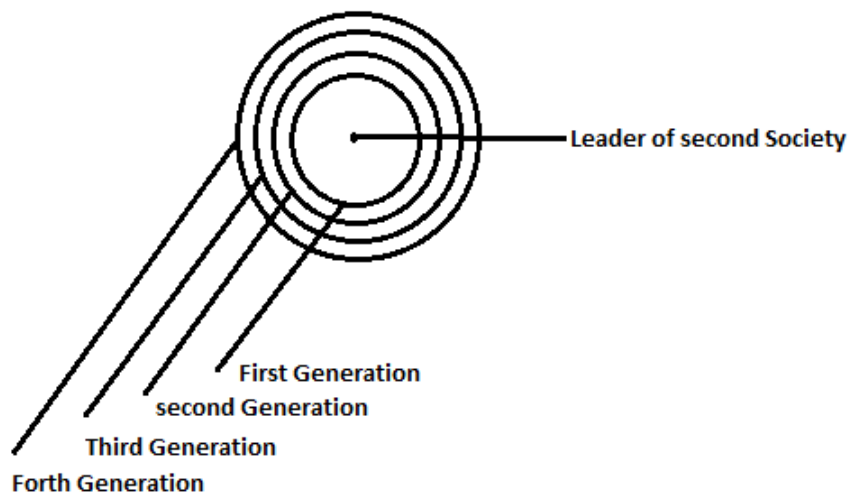

**Figure 15: Process of finding Best leader**

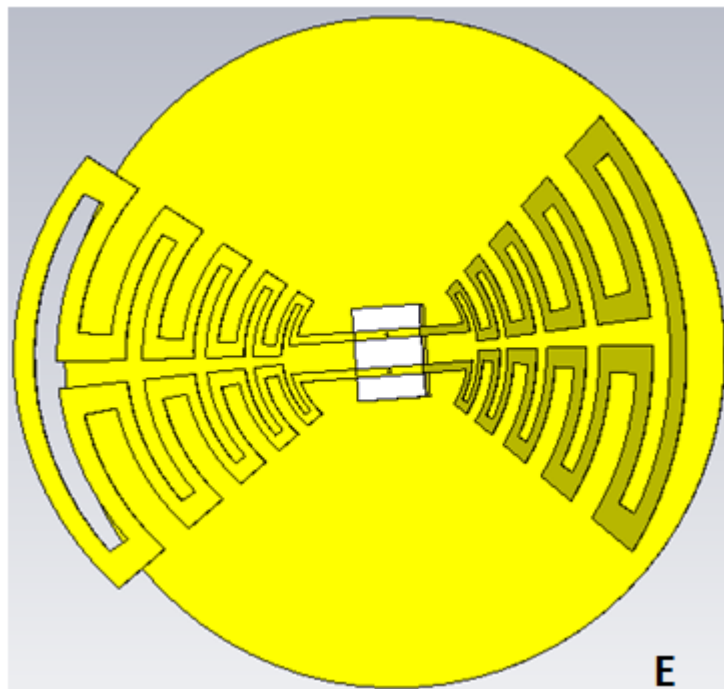
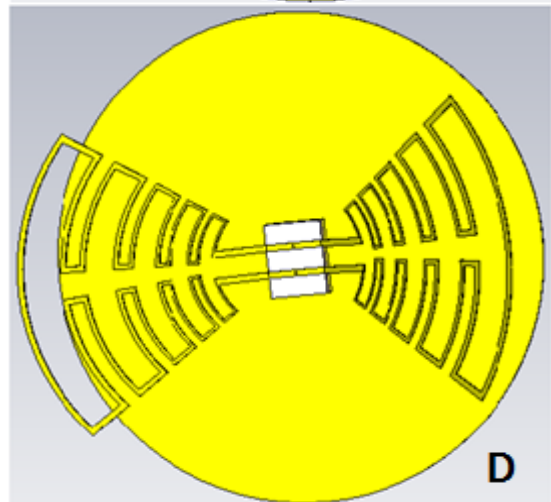
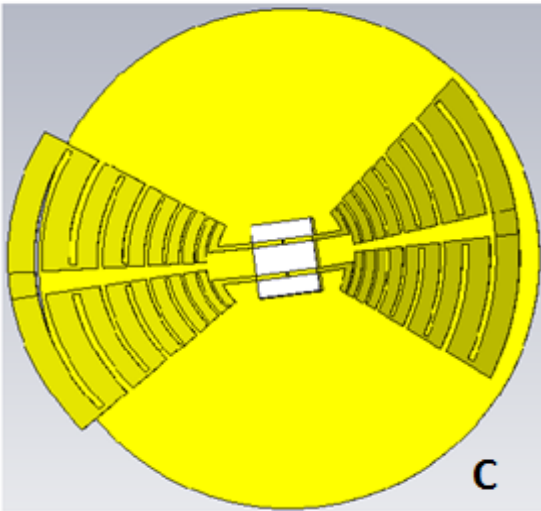
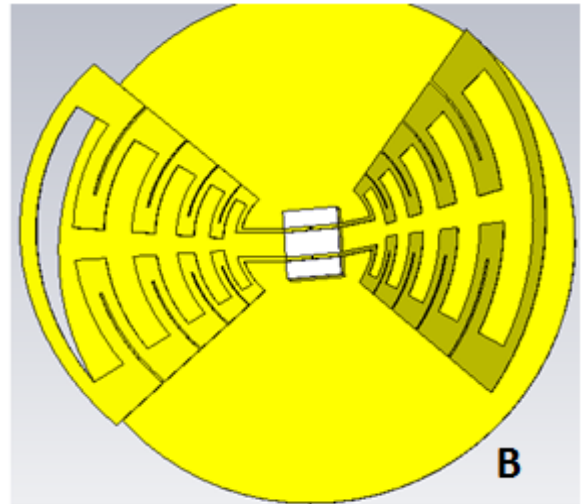
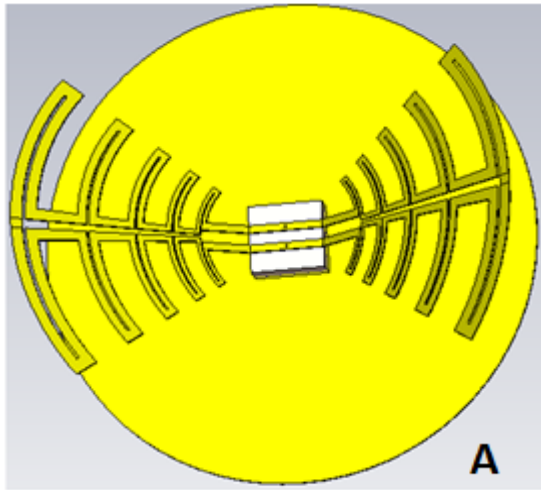

Figure 16: Leaders of the clusters

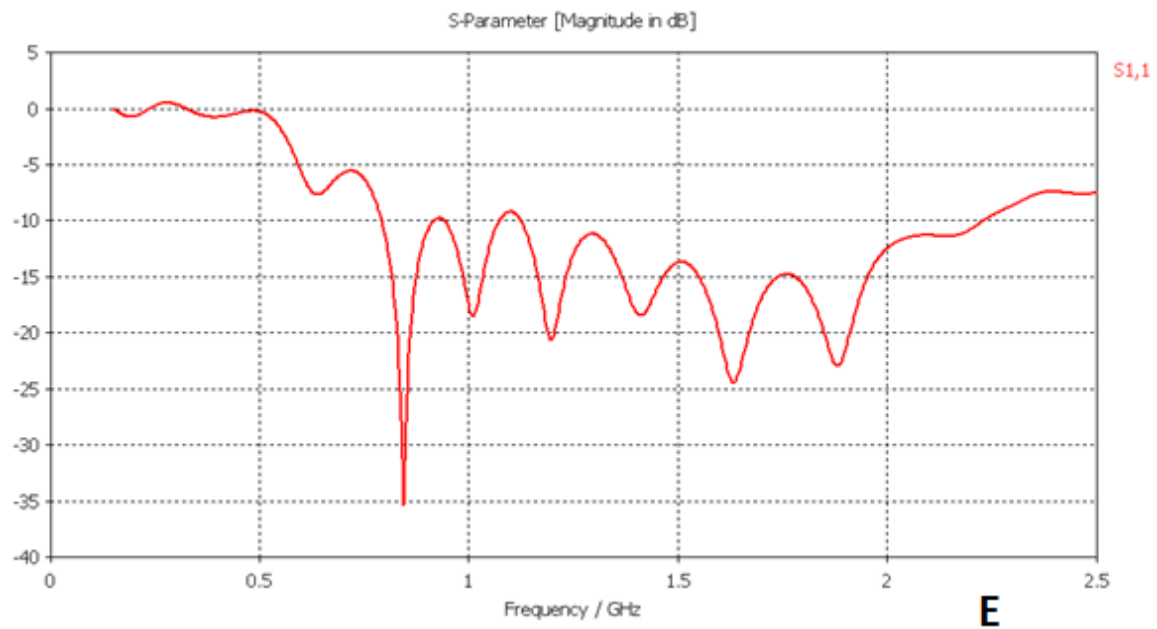
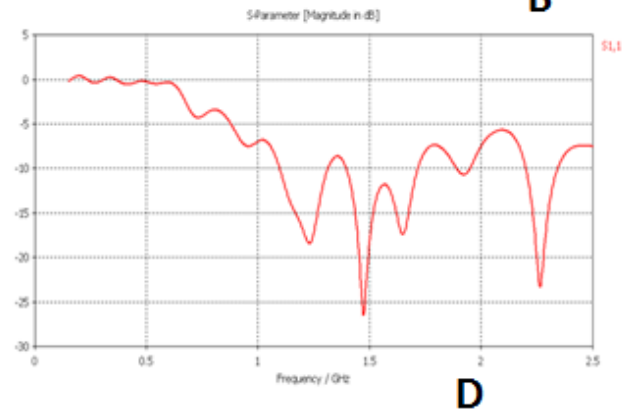
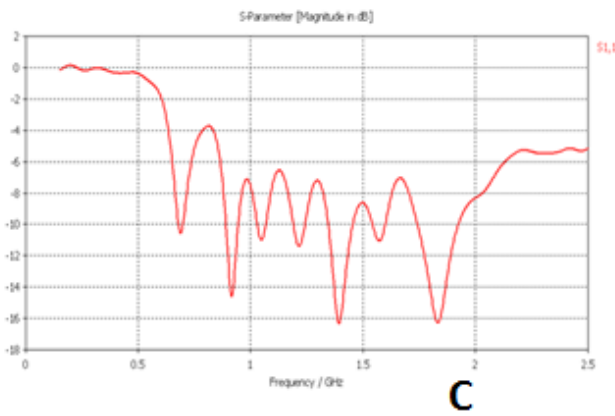
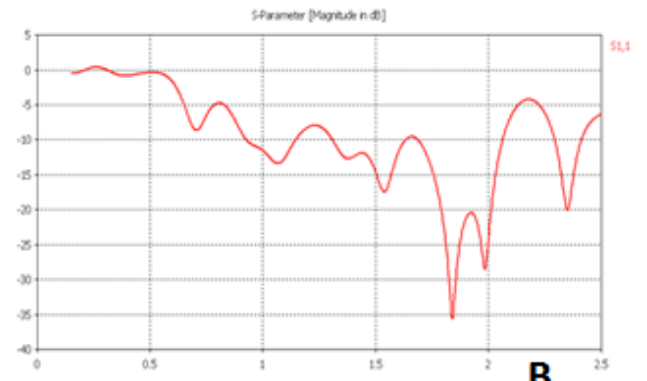
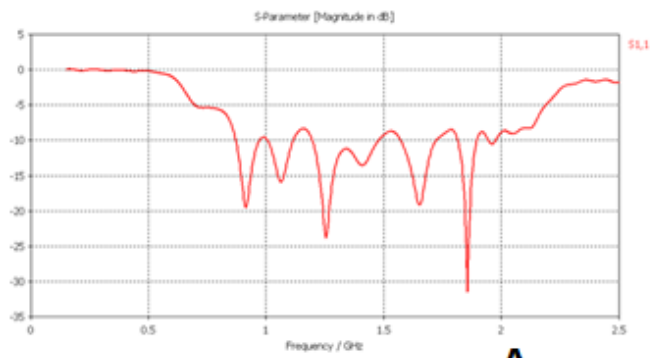
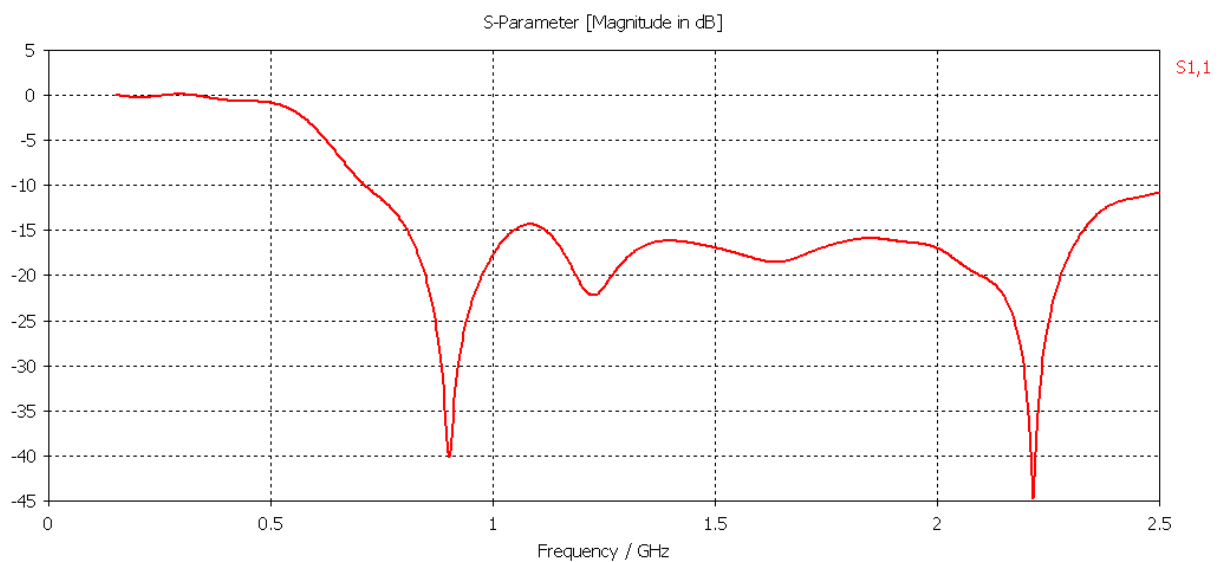
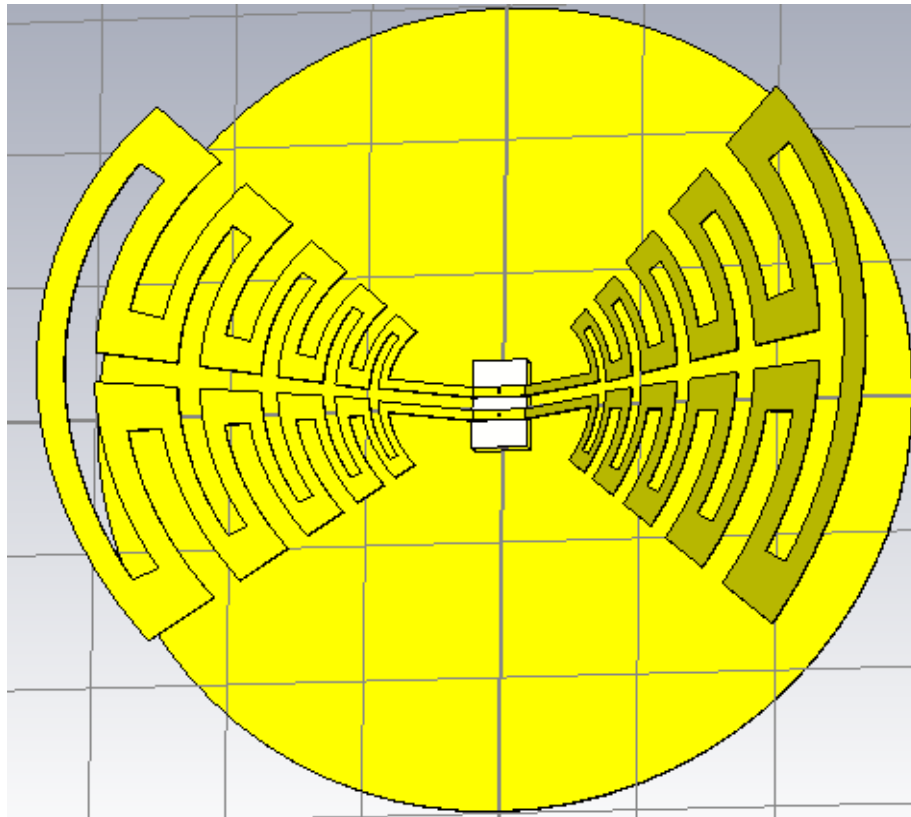

Figure 17: Reflection Coefficient of Leaders



**Figure 18: Best Leader**

When we added the orthogonal dipole petal to our design and did the simulation again it was found that at the beginning and higher end of the frequency band, the input reflection coefficient degraded almost to -12dB which is shown in figure 17.

Then we tried to design the center part and add the mechanical support to make the antenna more stable which also has a strong influence on the input reflection coefficient.

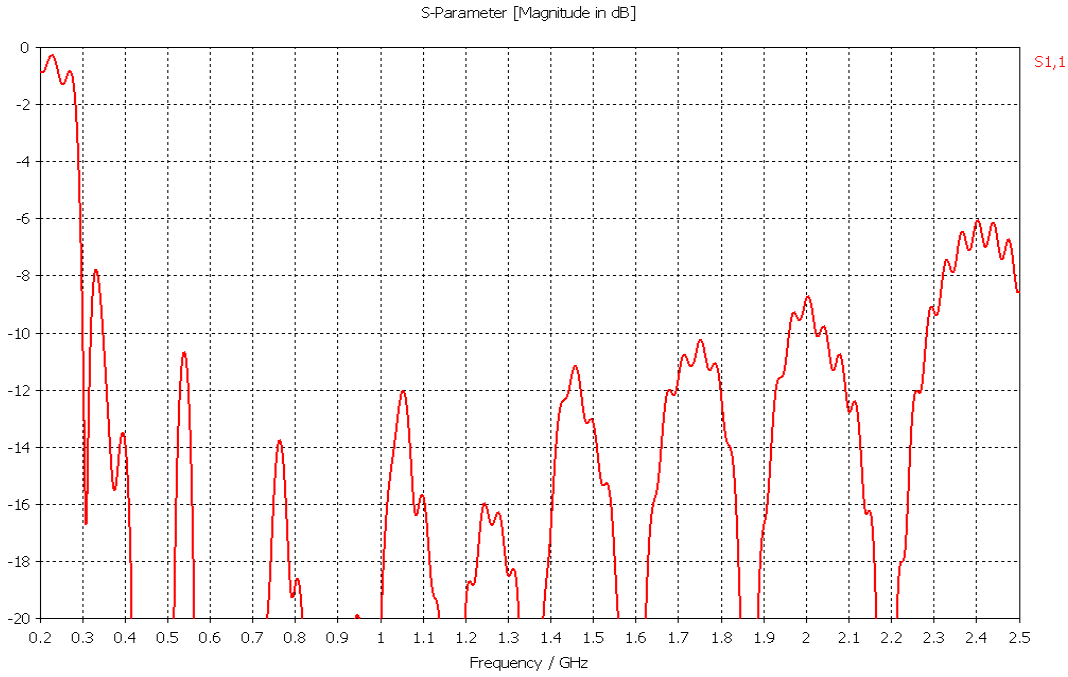
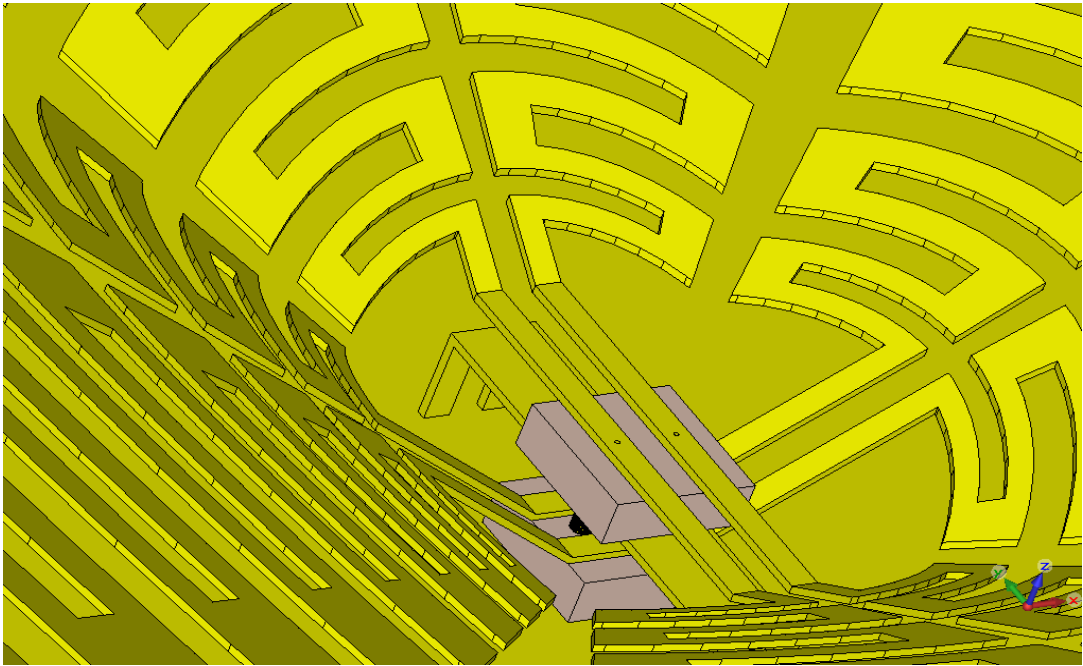

Figure 19: Impact of orthogonal dipole petal on the reflection coefficient

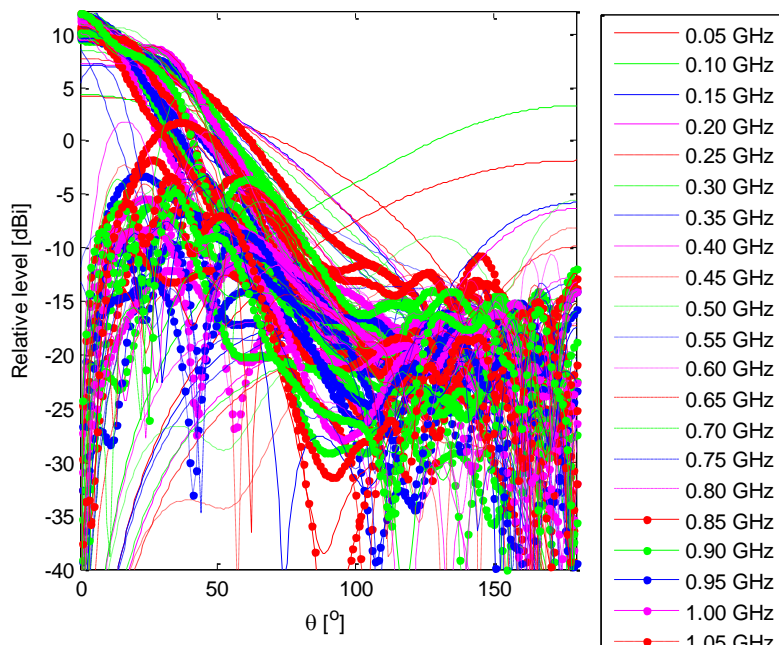
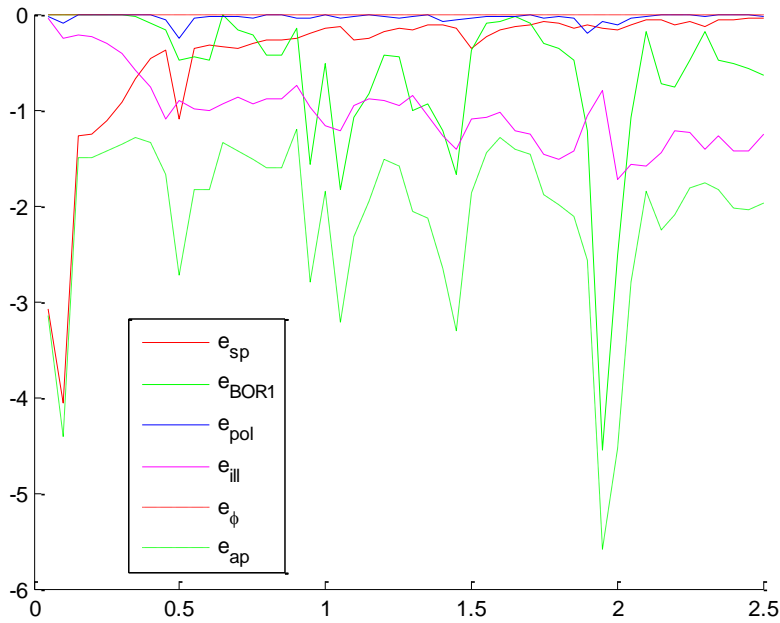

Figure 21: simulated antenna efficiency in frequency band 0.3-2 GHz

The embedded radiation efficiency is the contribution of the ohmic efficiency, reflection efficiency and aperture efficiency that the ohmic efficiency consists of conductor and dielectric efficiency in antenna material.

The aperture efficiency can be further factorized to five other sub-efficiencies.

A low efficiency coefficient of eleven-antennas has been achieved over a band frequency 300-2000 MHz.

The simulation shows that efficiency coefficients of a linearly-polarized eleven-antenna are all above -3 dB over 0.3–2 GHz bandwidth.

## References

- [1] P. Hall, *The SKA: An Engineering Perspective*, New York, 2005.
- [2] A. Niell, *Current and Future Requirements for Geodetic VLBI Systems*, 2005.
- [3] J. B. Anderson, *Digital Transmission Engineering*, Wiley, 2005.
- [4] P.-S. Kildal, *Foundations Of Antennas*, Spring 2009.
- [5] D. K. Cheng, *Field and Wave Electromagnetics*, Addition-Wesley, 1989.
- [6] P.-S. Kildal, "Equivalent circuits of receive antennas in signal processing arrays," *Microwave Opt. Tech. Lett.*, Vol. 21, No. 4, pp. 244-245, May 1999.
- [7] R. Olsson, P.-S. Kildal and M. Shields, "Measurements of a 150 to 1700 MHz low loss eleven feed for the 42 m radio telescope at green bank," *Proc. IEEE In. Symp. on Antennas and Propagation*, July 2006.
- [8] R. Olsson, P.-S. Kildal, and S. Weinreb, "The Eleven antenna: A compact low-profile decade bandwidth dual polarized feed for reflector antennas," *IEEE Trans. Antennas Propag.*, vol. 54, no. 2, pp. 368–375, Feb. 2006.
- [9] J. Yang, X. Chen, N. Wadefalk and P.-S. Kildal, "Design and realization of a linearly polarized eleven feed for 1-10 GHz", *IEEE Antennas Wireless Propag. Lett.*, vol. 8, pp. 64-68, April 2009.
- [10] J. Yang, M. Pantaleev, P.-S. Kildal, B. Klein, Y. Karandikar, L. Helldner, N. Wadefalk, C. Beaudoin "Cryogenic 2-13 GHz Eleven feed for reflector antennas in future wideband radio telescopes", *IEEE Trans. on Antennas Propag.*, vol. 59, no. 6, pp. 1918-1934, June 2011.
- [11] J. Yang, M. Pantaleev, P.-S. Kildal and L. Helldner, "Design of compact dual-polarized 1.2-10 GHz Eleven feed for decade bandwidth radio telescopes", *IEEE Trans. on Antennas Propag.*, vol. 60, no. 5, pp. 2210–2218, May 2012.
- [12] A. Yasin, J. Yang and T. Ostling, "A novel compact dual band feed for reflector antennas based on choke horn and circular Eleven antenna", *IEEE Trans. on Antennas Propag.*, vol. 57, no. 10, pp. 3300-3302, Oct. 2009.
- [13] J. Yang, D. Nyberg and J. Yin, "Impedance matrix of a folded dipole pair under Eleven configuration", *IET Microwaves Antennas Propag.*, vol. 4, no. 6, pp. 697-703, June, 2010.
- [14] J. Yang, "On Conditions for Constant Radiation Characteristics for Log-periodic Array Antennas", *IEEE Trans. on Antennas Propag.*, vol. 58, no. 5, pp. 1521-1526, May, 2010.
- [15] Jian Yang, "Periodicity of input impedance of log-periodic array antennas", *IET Microwaves Antennas Propag.*, vol. 6, no. 10, pp. 1117–1122, 2012.
- [16] J. Yin, J. Yang, M. Pantaleev, and L. Helldner, "The circular Eleven antenna: a new decade-bandwidth feed for reflector antennas with a high aperture efficiency", *IEEE Trans. on Antennas Propag.*, vol. 61, no. 8, pp. 3976–3984, August 2013.
- [17] J. Yin, J. A. Aas, J. Yang and P.-S. Kildal, "Monopulse tracking performance of multi-port Eleven antenna for use in terminals for satellite communications", *In 2nd Eur. Conf. on Antennas Propag. (EuCAP2007)*, Edinburgh, 11-16 November 2007.
- [18] CST Microwave Studio, 3D EM Simulation Software. [Online].
- [19] Y. B. Karandikar, "Pattern studies of two parallel dipoles in Eleven configuration above ground plane as feed for reflector antenna," *IEEE Antennas Wireless Propag. Lett.*, vol. 9, pp. 558–561, 2010.
- [20] T. Weise, *Global Optimization Algorithms Theory and Application*, Self-Published, 2009.
- [21] T. Ray and K. M. Liew, "Society and civilization: An optimization algorithm based on the simulation of social behavior," *IEEE Transactions on Evolutionary Computation*, vol. 7, no. 4, pp. 386–396, 2003.
- [22] R. L. Haupt, "An Introduction to Genetic Algorithms for Electromagnetics," *IEEE Antennas and Propagation Magazine*, vol. 37, no. 2, pp. 7–15, 1995.
- [23] J. Yang, P.-S. Kildal, "Optimizing large log-periodic array by computing a small part of it", *IEEE Trans. On Antennas Propag.*, vol. 59, no. 6, pp.1790-1797, June 2011.
- [24] R. L. Haupt and D. H. Werner, *Genetic Algorithms in Electromagnetics*, John Wiley & Sons 2007.

## Appendix:Matlab Codes

```
function pop = B0_initPop(N)

% N - size of population
lamda= 150mm;

pop = zeros(N,50); %N is the size of population; 50 is the size of genes

pop(:,1) =10.660300+ 16*0*(rand(N,1)-0.5)/8;

% H: Height of Teflon substrate which the transmission line is lie on
in mm

pop(:,2) =3.709980 + 2*0*(rand(N,1) - 0.5)/8;

% W: Width of Transmission Line in mm

pop(:,3) =12.316000+ 20*0*(rand(N,1)- 0.5)/8;

% D: Distance between Transmission Lines

pop(:,4) =(0.25 + 0.0*(rand(N,1) - 0.5))*lamda;

% R1: the radius of the first cylinder for the first dipole, in terms
of wavelength

pop(:,5) =2.394900+0*(0.0179892067 + 0.005*0*(rand(N,1) - 0.5))*lamda;

% W1: Width of Folded dipole arms
```

```
pop(:,6) =7.454600+0*(0.0557057067 + 0.015*0*(rand(N,1) - 0.5))*lamda;
```

```
% S1: Parameter that define the geometry of petal
```

```
pop(:,7) =1.337904+ 0.025*0*(rand(N,1) - 0.5)/8;
```

```
% K: Scaling Factor
```

```
pop(:,8) =35.970600+ 8*0*(rand(N,1) - 0.5)/8;
```

```
% alfa0: Angel of tilted Folded metal plate respect to x-y plane
```

```
pop(:,9) =39.749900+ 8*0*(rand(N,1) - 0.5)/8;
```

```
% alfa1: Parameters that define the geometry of petal
```

```
pop(:,10) =2.573300+ 4*0*(rand(N,1) - 0.5)/8;
```

```
% alfa2: Parameters that define the geometry of petal
```

```
pop(:,11) =5.776100+ 8*0*(rand(N,1) - 0.5)/8;
```

```
% alfa3: Parameters that define the geometry of petal
```

In order to avoid producing disabled chromosomes or antennas, some requirements have been applied to create suitable genes which can generate appropriate chromosomes or antennas but maybe not the optimum ones:

1) Outer radius of auxiliary cylinder should be greater than inner radius:

$$R_1 + S_1 - W_1 > R_1 + W_1 \Rightarrow S_1 > 2W_1$$

$$R_2 > R_1 + S_1 \quad R_2 = R_1 \times K \Rightarrow R_1 \times K > R_1 + S_1$$

2) The Maximum and Minimum of Central Part (Teflon Substrate)

$$[(W + D/2) \times \tan \alpha_0 / \tan \alpha_1] + 1 < H < R_1 \cos \alpha_1 \times \sin \alpha_0$$

3) The Maximum and Minimum Distance between Transmission Lines:

$$R_1 \sin \alpha_2 \leq D/2 \leq R_1 \sin(\alpha_1 - \alpha_3) - W$$

```
function out = B_checkGenes(pop)
```

```
N_size_population = size(pop,1);
```

```
for n=1:N_size_population
```

```
    A=(pop(n,2)+0.5*pop(n,3));
```

```
    B= tand(pop(n,9));
```

```
    C=tand(pop(n,8));
```

```
    if (pop(n,6) > 2*pop(n,5)) && ( pop(n,4)*pop(n,7) > pop(n,4)+pop(n,6) )
```

```
        && ( pop(n,1) < pop(n,4)*cosd(pop(n,9))*sind(pop(n,8)) )
```

```
        && ( pop(n,1) > (A*C/B)+1 ) && ( pop(n,4)*sind(pop(n,10)) <= 0.5*pop(n,3) )
```

```
        && ( 0.5*pop(n,3) <= pop(n,4)*sind(pop(n,9))-pop(n,11)-pop(n,2) )
```

```
            pop(n,50)=1;
```

```
    end
```

end

out = pop;

% (1) : outer radius > inner radius -->  $(R1+S1-W1) > (R1+W1)$  -->  $S1 > 2*W1$

% (2) : outer radius > inner radius -->  $R2 > (R1+S1)$  -->  $R1*K > R1+S1$

% (3) : Maximum and Minimum of Height of the Teflon Substrate

%  $[(W+D/2)*\tan(\text{alfa0})/\tan(\text{alfa1})+1] < H < R1*\cos(\text{alfa1})*\sin(\text{alfa0})$

% (4) : Maximum and Minimum of Distance between Transmissions line

%  $R1*\sin(\text{alfa2}) \leq D/2 \leq R1*\sin(\text{alfa1}-\text{alfa3}) - W$