



## Place through encounter

- an exploration of a Third Place in the  
urban context of Partille

Hiltja Harmuth

Chalmers School of Architecture  
Department of Architecture and Civil Engineering  
2023

Examiner: Nils Björling  
Supervisor: Marco Adelfio





**CHALMERS**  
UNIVERSITY OF TECHNOLOGY

Place through encounter  
- an exploration of a Third Place in the urban context of  
Partille

2023

Hiltja Harmuth

Chalmers School of Architecture  
Department of Architecture and Civil Engineering

MPDSD | Architecture and Planning Beyond Sustainability

Direction: Urban Transformations

Examiner: Nils Björling  
Supervisor: Marco Adelfio



## ABSTRACT

Rurban areas in particular are affected by the ongoing challenges through urbanization and densification. Vast and fast changes in infrastructure and prerequisites may result in a loss of connection of the individual to their surroundings, leading in turn to a minimized sense of conviviality and liveability. Third places, the social surroundings beyond the home as the first and work as the second place, can play an important role in acting as facilitators of change and act as connectors of the individual to the broader community.

The main aim of the Thesis is to explore how encounters can be enabled in a rurban context, through design implementations that are informed by third place qualities.

To set the ground for design, the notion of a third place was explored through different methods of theoretical and contextual analysis, to investigate how the concept of these places needs to adapt to the current discourse and the specific characteristics deriving from the context. These findings were concluded in principles for the third place, that further guided the process.

In design explorations through collages and axonometric drawings the Thesis investigates in a narrative way, how the former electrical factory Kniven in Partille, can be adapted to act as a third place.



## Glossary

### Rurban

"places" / areas that bridge the gap between the dichotomy of rural and urban. They are in close proximity to both urban and rural spaces and effected by changes (demographic, spatial, economic), that are deriving from the development of their surrounding areas.

### Community

a group of people that can be identified as a social unit, being a result of commonalities such as interests, background or the spatial area they live in.

Not static, rather fluid. One community consisting of smaller groups and several units/communities.

### Centres for community

a public location (place or building) where different social units can gather and participate in varying activities, either individually or as a group.

A place that can foster community / connect an individual to it's surrounding community.

## Reading instructions

The thesis is divided into six chapters, each of which refers to the previous chapter and enables a multidimensional examination of the chosen topic.

The introduction to each chapter is a short description of the points examined in order to provide the reader with an overview.

Theory and contextual analysis provide the base for design considerations. The thesis is framed by a summary of the general background and a concluding discussion of the thesis question.



# Table of Content

## Abstract

### Chapter 1 : Introduction 6 - 13

Background / Problem statement  
Context  
Aim + Thesis Question  
Delimitations  
Process  
Methods

### Chapter 2 : Theoretical Framework 14 - 23

Third Place Theory  
The current discourse - towards a new type of third place  
Benefits and importance of third places  
Place Attachment and Place Concept  
Third places in the scope of the Thesis

### Chapter 3: Contextual Analysis 24 - 39

Transects  
Spatial analysis of the immediate surroundings  
Third Place mapping an investigating relations  
Kniven today - understanding the ongoing activators  
Force field analysis - understanding forces for and against change  
Narrowing down the site

### Chapter 4: Setting the ground for design 40 - 45

CUI BONO? - Narrowing down the users  
Setting the programme  
Design Principles

### Chapter 5: Design Explorations 46 - 71

Spatial organization  
Building elements to enable a Third Place and interactions  
Creating a narrative through collages and sketches  
Comprehensive synthetic axonometric overview

### Chapter 6: Reflection and Discussion 72 - 77

### Chapter 7: Appendix

student background  
references  
additional material







## Introduction

This chapter will provide the reader with an overview of this thesis' content.

It introduces the background, context, aim and research question of the thesis and further reflects on the process and methods used to develop and discuss the thesis' topic.

## Background and problem description

Communities and neighbourhoods in the periphery of bigger cities face a variety of challenges.

They are strongly affected by changes deriving from urbanisation and globalisation - in consequence these areas often face a loss in social cohesion and place identity.

To enable those areas to withstand changes and create a stronger representation in the overall discussion of spatial development, the focus needs to shift to the creation of quality of life / quality of stay, that is defined by both objective and subjective factors.

An important factor is to create the opportunity for residents in rural areas to develop and create an attractive living environment, a good business climate and a strong community life.

Third places can be a contribution to both of these factors and can act as facilitators of, and centres for community.

These places function as "the hub" in the neighbourhood and are enablers for the development of local associations and business life. The premises contribute to different types of community services being able to remain and develop in the locality. The meeting room also constitutes an important democratic infrastructure where interpersonal meetings for democracy, culture and integration take place.

The interested search for third places in one's own environment motivates people to follow their concrete steps. With such a look at social and physical movements, spaces open up. And the spatial appropriation that people „go through“ lights up as a productive, emancipatory project of developing living environments, even beyond the cities. Locating third places

in rural areas, and also understanding these meeting points as particularly endowed by art and culture, requires certain theoretical prerequisites that are particularly related to the understanding of third places as spaces of possibility. (Drews, 2021)

The positive implications can be discussed on the individual and greater community level.

For the individual, to have a third place to go to after work or school, can result in stress relief, a feeling of inclusiveness and belonging, without the rigidity of policy or exclusivity.

For the greater community, they can foster commitment to local politics via informed public discourse and at the same time increase the feeling of safety and security. (Jeffres et al., 2009)

As many former industrial buildings, such as factories or storage buildings are currently unused, new spaces of possibility open up. Residents of areas around those buildings often feel a strong connection towards them, which can be a great asset in the search for a suitable place for the creation of community buildings, that provide the user with the intrinsic qualities of third places. Making use of these potentials, could result in a stronger connection to the neighbourhood, contribute to community building and liveability of the near surroundings.





## Context - Partille

### Overview of location, history and characteristics

Partille municipality is located around ten kilometres east of Gothenburg Centrum in the Västra Götalands Region. The history of Partille dates back to the Middle Ages. Over the centuries, the municipality has varied in size and composition. It was divided into smaller administrative areas for a number of years before it was designated a municipality in its present form in 1971.

With the arrival of the Industrial Revolution in the Swedish context, Partille also changed and grew. In the 1830s, the first industries, including a spinning mill and a manufactory, settled in the area around Partille centre. As development progressed, Carl Eck's engine factory was established in the centre of Partille, near the railway station in the Kniven quarter. The remaining buildings of this factory, which have been used for other purposes and have undergone architectural changes over the years, are the subject of this work. (Partille municipality, 2022)

Today Partille can be categorised as a suburban area (see Glossary). It consists of more urbanised and densely populated areas as well as nature and agricultural land and is situated on the fringes of a densely populated urban centre (Gothenburg). (Partille Municipality, 2022)

### Synergies and changes

Through the ongoing development and expansion of Gothenburg, the municipalities are continuously growing closer, in consequence affecting each other in terms of densification, urbanisation and flows of people. This also includes an exchange of people who go in and out of the municipality to work. (Partille Municipality, 2022)

While this transformation is progressing, Partille as a municipality and place is changing. A reaction to this development is the target image 2035 (Målbild 2035), developed in 2021 by the municipality of Partille. In the paper, it is predicted, that Partille centre, with the adjacent north and south areas, will grow in size and number of inhabitants, changing the demands for housing and business areas. These developments are also presented in the detailed plans for the areas.

The target image identified strengths and weaknesses of the area's current characteristics. (Målbild Partille Centrum 2035, n.d.-b)

## Aim and Thesis Question

The main aim of the thesis was to investigate the notion of third places in a rural context, discussing both why such a place is needed in the specific context of Partille and how the design could be approached to enable encounters and interaction within it.

This will be achieved through an iterative process, that includes both literature research, spatial and needs analysis as well as testing out design ideas in theoretical prototypes.

The thesis' purpose is to explore the potential positive impacts of the implementation of a third place in the periphery of a bigger city.

Understanding the context of the site as well as the theoretical background helps to create a foundation for the thesis.

How can encounters be enabled in a rural context through design implementations informed by third place qualities?

sub questions:

How do the theoretical parameters of a third place need to be adapted to the current discourse ?

How does the rural context of Partille inform and influence the third place and vice versa?

## Delimitations

### The Thesis...

#### IS ABOUT

- Ideation and design for a third place: the thesis addresses the question of how a design for a third place can be approached in the specific context of Partille
- Place relations: The Thesis will explore how a designed place can contribute to peoples' sense of belonging and relation to place.
- Iterative Processes and Methods: The thesis development will consist of alternating phases of experimentation, research and evaluation. Different methods are used to approach the topic from diverse angles
- Narrative approach: Through different mediums such as axonometric drawings, collages and sketches a narrative approach to the topic is tested out.

#### IS NOT ABOUT

- Technical transformation proposal: The thesis does not examine in detail how the transformation of an existing building can be approached. In the context of this thesis, space is understood as a social construct that can only be formed through interaction within it. The existing building serves as a test bed for these considerations.
- Participatory design: To approach the thesis topic informal interviews with people and actors on site were carried out, but the thesis does not revolve around participatory design approaches.
- Management and maintenance: The thesis does not discuss how the proposed third place can be managed and maintained after its implementation.



# Process

The process of the Thesis was guided by an overarching approach in combination of Research by Design and Research for Design. In an iterative process, these research approaches were supported by and carried out through the application of several different methods, focusing on both theory, context and design.

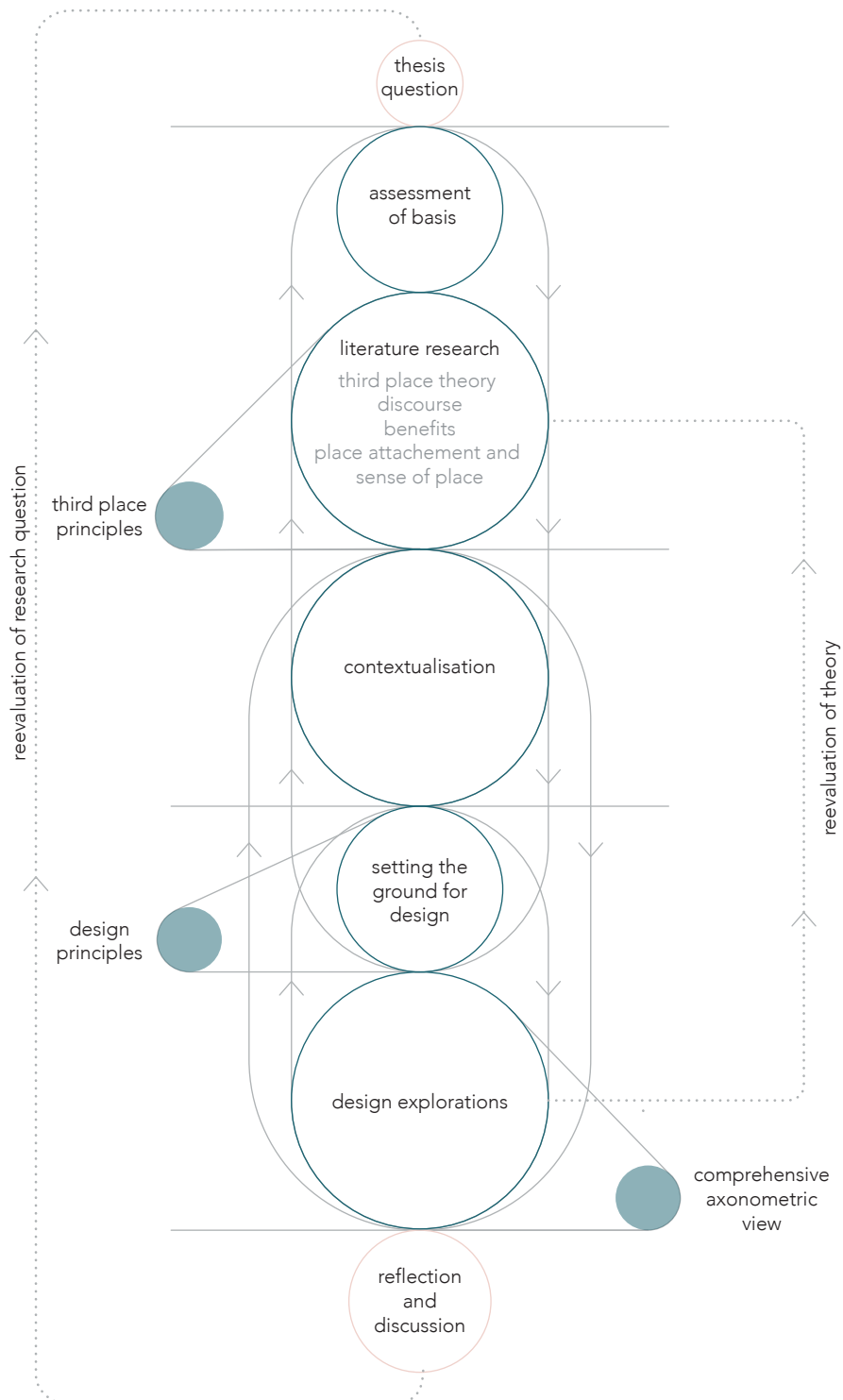

# Methods

## Theory Focused Methods

### Literature Study.

Literature in different forms, such as books, articles, journals, reports and more will provide the necessary theoretical framework and background information to ground and support the design process.

### Discussion / Reflection on Literature.

The findings from the literature research have been discussed in order to conclude the main takeaways in principles, that guided the further thesis process.

## Context Related Analytical Methods

### Document Study.

Municipal documents have been studied to identify challenges and needs that should be addressed in the scope of the thesis. The outcome of these studies founded the base for identifying forces in favour of and against change.

### Site visits and analysis.

On several occasions in the thesis' process site visits were carried out. This happened in combination with informal interviews with ongoing activators and users. Hereby the building itself and the immediate surroundings were put in focus.

### Mapping.

Mapping in different ways was used as a tool to navigate the context, get a better understanding of the spatial relations between the chosen site and its surroundings. Targeted topics were infrastructure, composition of the built fabric, green areas and functions.

### Transects.

Transects were used as a method to further investigate spatial relations in a broader context, to help identify the specific qualities that render the context of a urban environment. The application of this method was carried out through studying maps, taking walks through the area and a photo documentation.

### Third place mapping and network.

Introducing a new third place to the context, influences how the existing places, that can be identified and categorized as third places, are connected with each other. Therefore these existing places were mapped and put in relation to each other in a network.

### Force field analysis.

A force field analysis was used as a tool to identify restraining and driving forces, that could influence the formation of a third place in the specific context of Partille and the existing building.

## Design Related Methods

### Iterative collages.

Collages were used to investigate the buildings potentials to be transformed into a third place surrounding. In an iterative process, they were further used as a design outcome, to illustrate the interactions that happen within the place.

### Sketching.

Sketching was used as a method to approach the early design stage and test out ideas for the further progression of the project. A combination of digital and traditional sketching methods was used.

### Comprehensive axonometric view.

A comprehensive axonometric view is used as a tool to synthesise the findings from the theoretical framework, contextual analysis and design explorations. It concludes the design chapter and brings together functions, structural elements and interactions in a final scenario in the specific context of the existing building frame of Kniven.





## Theoretical Framework

In this chapter the theory of third places according to Ray Oldenburg will be discussed and placed in the current discourse. Criticisms regarding the theory will be considered as well as current interpretations and new dimensions that are being debated in this context.

In the following, these theoretical considerations will be placed in relation to urban spaces in order to be able to formulate a context-specific definition in the further course of the thesis.

## The Third Place Theory

This thesis has its starting point in the theory on Third Places. The following summarizes this theory to create a base for further explorations. As defined by Ray Oldenburg in „the great good place“ (1989), Third Places are the social spaces separate from the home as the first place and the work as the second place. Following this definition, Third Places are socially relevant meeting points in the neighbourhood or surroundings on people’s everyday routes between the first and second place. He argues, that people tend to spend their time mostly in the dichotomy of their home as the first place, and work as the second place.

He further describes that this is rooted in the fact that there is a loss of quality, availability and variety of spaces for regular, informal and spontaneous encounters. (Oldenburg, 1989)

Oldenburg further provides the reader with eight characteristics for defining or identifying these places. These are:

## On Neutral Ground

Third places are on neutral ground, meaning that the individuals engaging in the place do not feel an obligation to be there. The individual should feel that they can “come and go as they please” (Oldenburg, 1989, p. 22). Oldenburg argues that this characteristic can help to ensure, that people socialize beyond their usual patterns and with people outside of their personal social bubble. (Oldenburg, 1989)

## Conversation is the main activity

The Third Place as such is defined by conversation being the main activity. Oldenburg argues that with a third place being on neutral ground and a leveller, conversation does not only become easier, but also more enjoyable and thorough. He proceeds to compare conversation to a game, indicating that individuals can engage in a more playful and light-hearted conversation atmosphere. (Oldenburg, 1989)

## The Mood is Playful

The overall mood and atmosphere of a third place is characterised by playfulness. Staying in these places is dedicated less to a specific purpose or goal than to spending time in other people’s company. This characteristic contributes to the individual’s wish to spend time in that place repeatedly. (Oldenburg, 1989)

## A Low Profile

For a Third Place to feel accommodating, it needs to be characterised by a low profile to be able to evoke the feeling of “homeliness”. They are not designed to appeal to a certain standard and often grew in places that originally served another purpose, out of the desire to find a place to spend time in the company of others. A low profile further helps to lower thresholds and incorporate the place into the individuals everyday routine (Oldenburg, 1989).

## A Home away from Home

Third Place are described as a “home away from home” - a place that offers a “congenial environment” in a more or less public setting. It provides the individual with the possibility to root themselves, feel at ease and regenerate. A sense of ownership and being able to shape their surroundings further contributes to the feeling of being at home in a place. (Oldenburg, 1989)

## The Third Place is a Leveller

Third Places act as levellers for social and economic differences, meaning that they equal out any difference and create equality. Through being levellers, they become democratic and inclusive places, that are accessible to the general public. Because of the absence of constructs such as memberships, third places expand possibilities to socialise beyond social ranks. (Oldenburg, 1989)

## The Regulars

Place regulars are vital to giving the place character, make it come alive and create an atmosphere of conviviality. The regulars ensure ongoing activities and can thus play a vital role in attracting newcomers to the place. (Oldenburg, 1989)

## Accessibility and Accommodation

Third Places are accessible and accommodating. The individual should have the opportunity to go to such a place at “any time of the day or evening” and be able to meet others to engage with. The availability of the place at any given time is as important as the unplanned character of the ongoing activities and the location being in proximity to everyday environments. (Oldenburg, 1989)

## The current discourse - towards a new type of third place

Third Places as such, their definition and reception are not rigid concepts. In the current discourse, the critiques of the original definition play just as much a role as the consideration of current developments, such as globalisation and densification.

### Accessibility

A frequently discussed aspect of the definition of Third Places is the question of whether these places are actually accessible and without thresholds.

Already in the title of his book "The Great Good Place", Oldenburg is hinting at the places that he considers as third places. He refers to Cafés, Coffee Shops, bookstores, bars and hair salons. When he is outlining the overall problem, the loss of sojourn quality and (informal) meeting spaces in the American suburbs, he is often referring to what he sees as the "typical European hangouts" and bases his theory for the third place on the characteristics and his observations of these places. (Oldenburg, 1989) When looking at the examples of places he describes, it becomes evident that they often have in common to be based around and require consumption of either services or goods.

Yuen and Johnson (2016) argue that the solely consumer-oriented aspects of some of the described places lead to the reinforcement of so-called "life-style enclaves", meaning that they mostly attract people that share similar features of private life, such as shared patterns in consumption, interests and even appearance. Thus these places become rather exclusive than accessible. In conclusion, they argue that the



aspect of accessibility must be given special attention in the third place debate. They further emphasise the importance to consider third places as dynamic and diverse places, that can respond to the community they are situated in and adapt to changing demands. (Yuen et.al., 2016).

### Merging of the place typologies and creative potentials

The literature further suggests that a division into three places can no longer meet today's standards. For example, due to an increase in the possibilities and necessities of working from home, the boundaries between the first and second place are blurred. At the same time, there is a trend for individuals to seek out places for informal social interaction throughout the week and during working hours. (Slater & Koo, 2010)

The emergence of the so called "community hubs" further suggest a trend towards combining the place typologies. Living, working and leisure are not seen as opposed to each other, but as synergies that promote and benefit each other - joint production and exchange are central elements. (Klassen, n.d.). A mix of uses, as well as different users from the fields of community interest, culture and small businesses, further favours this exchange. These community hubs or third places can thus become the "heart of the community". (Murray, 2014)

Furthermore, Third Places as spaces in which communication is given an important role are often discussed from a socio-cultural point of view, especially outside urban areas. The desire

for civic participation and community can be particularly strong in these areas. Art and culture have the potential to contribute to community building in particular because they are able to involve individuals as creators of their own living environment. Here, learning from each other and with each other becomes important and building on the existing creative potentials becomes even more important. (Drews, 2021)

## Benefits and Importance of Third Places

To get a better understanding of why a Third Place is needed in a rural context such as Partille, its benefits and importance on the individual and greater community level need to be discussed.

Literature indicates, that the availability of a third place in ones near surroundings can have positive impacts on both of the aforementioned scales.

### Individual level

Third Places are often described as public spaces for interaction where aspects of leisure, work and socialisation are catalysed into a surrounding that promotes and enhances the sense of belonging for the individual. (Wexler & Oberlander, 2017). Quality of life and social well being can be positively impacted by engaging in activities in a third place and lead to stress relief and feelings of inclusiveness. (Jeffres et.al., 2009)

They also create an environment where individuals can take a break from everyday life (Lee, 2022), encouraging spontaneous and informal encounters that foster new stimuli and emotional connections. (Jeffrey et.al., 2009)

A particular challenge for third places in rural areas is to bridge the perceived differences between the restorative character of urban and rural places. (Lee, 2022) It is thus important to consider both the outdoor space and the immediate surroundings of the third place when choosing a location and programme for the third place.

### Community level

On a neighbourhood level the social attributes of third places can contribute to a different and more connected relation to the community, which is particularly important in areas that are undergoing major changes, for example in terms of population and building density. (Lee, 2022) Building on the benefits of the individual level, third places can positively contribute to neighbourhood diversity and cohesion, creating stronger connections and identification within the community. (Lee, 2022)

Providing a third place in the neighbourhood also means contributing to social inclusion. In their nature as communicative places, they can also strengthen commitment to local political causes and processes of social action and change. This increased connection to the neighbourhood and involvement in the general discourse also promotes a sense of security and safety. (Jeffres et.al., 2009)

Jeffres et al. (2009) further indicate that communities which can be characterised as diverse tend to state that there are few Third Places available in their proximate surroundings. It can be concluded that in a rural area like Partille, which is becoming more dense and diverse in the future as the population increases, these very places are needed to contribute to community building. Implicitly, this also means creating a diverse range of activities and qualities, to be able to respond to diverse needs.

## Place Attachment and Place Concept - Design of Physical Qualities of Stay

Widely discussed topics in relation to Third Places and the creation of physical qualities of stay, are those of place concept and place attachment.

### Place Concept

In this regard “place concept” is seen as a critical factor for the design of common spaces that enable both informal encounters in public space and (political and cultural) exchange.

In order to actually enable these aspects, certain design features are required that can also be traced back to social aspects and spatial behaviour patterns. (Pilzer, 2017)

In particular, the literature emphasises that the possibility of observing activities and other people in their interaction plays a central role, among other things, in promoting interest and interaction with each other. However, it is also important to give the individual some space for anonymity and choice in the activities they want to participate in. If these aspects are taken into account, a place can be created that is community oriented and also creates a sense of ‘home’ for the individual. (Pilzer, 2017)

In the context of this thesis, this means that a spatial structure needs to be developed that allows for different types of informal interactions and a variety of activities. This is always under the aspect that the requirements can change, so that an open possibility for development must be offered. Activities that can be observed in public spaces, such as people watching, lingering, eaves dropping and spontaneous encounters must also be made possible in a Third Place.

### Place Attachment

The second concept that plays a central role in the design of Third Places is place attachment. Space must be understood as a construct that goes beyond the solely physical element and is defined above all by the meeting and interaction of people and things with each other. Martina Löw describes spacing and synthesis as central elements in the creation of space - this includes question of location and association with place. (Löw, 2001)

Different levels of place attachment come into play here - cognitive loyalty (use-oriented), community loyalty (ties to the community and neighbourhood) and home loyalty (emotional ties). (Pilzer, 2017)

In the context of this thesis, this means creating spatial qualities and developing a spatial program that can facilitate and promote these different levels of attachment, as well as a more abstract interpretation of these spaces, i.e. investigating how interaction can be promoted in order to create space.

## Third Place Principles in the Scope of the Thesis

The literature review and discussion of various aspects that are relevant for the understanding and classification of Third Places in the current discourse open up the question of a revisitation and reformulation of the principles for Third Places.

As noted above, in order to realise their potential, Third Places need to adapt to the current needs of the community in which they are situated.

The merging of the boundaries between the first and third place creates wide new challenges for third places as social spaces, which also affects, among other things, the range of functions and diversity of a social place.

Especially in a rural area like Partille, Third Places need to be mediators between rural and urban areas in that they also have the potential to contribute to the exchange of these regions and to respond to the changing needs of the growing population.

Based on the findings of the previous considerations 6 third place principles have been defined, that will further guide the thesis' process. They are strongly intertwined with the existing principles, but consider additional aspects such as the shift towards less defined boundaries between the first and second place, as well as the need for third places to be able to withstand changes. The Third Place principles are later translated and put in relation to design principles to guide the design process.

## DYNAMIC

Third Places need to be dynamic in order to withstand changes in their surroundings. They need to respond to changing needs and societal prerequisites through an approach of adaptability and leaving opportunities for open end development.



## ENGAGING

Third Places should be engaging. They should create informal and inspiring settings and environments, that attract and invite a variety of users from the local community but also external visitors from the surrounding areas. To engage users to interact with each other, they should allow for opportunities of (cultural) exchange.

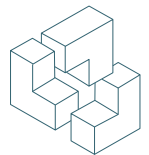

## DIVERSE

Third Places need to be diverse to be able to react to a variety of needs and accommodate for different user groups. They should provide programmed and unprogrammed spaces that are flexible to use simultaneously.

Both sedentary and active pastimes should be enabled, outdoor and indoor spaces need to be considered.

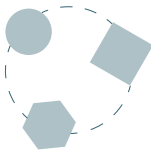

## PLACES FOR DISCOURSE

Third Places are places for discourse, where communication is a central element. Places are created through the communication within and about the place. Enabling discourse further enables identification with the place and participation in local processes.

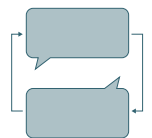

## GROUNDING IN THE EXISTING

Newly emerging Third Places need to be grounded in the existing. This means to include existing activators and ongoing activities in the programme. Further they need to respond to the local identity of the place, through creating place attachment and sense of place.



## HOME AWAY FROM HOME 2.0

The continuous blurring of the boundaries between the "three types of places" - home, work, social environments - needs to be considered when creating third places in terms of programming. They should feel safe and provide opportunities to engage in social activities during all times of the day, however also allow for the opportunity to detach from everyday life individually.







## Contextual Analysis

To contextualize the information gathered in the theoretical framework, the following chapter will consist of a thorough analysis of the context.

It starts off with a spatial analysis of the near surroundings to get a better understanding of the overall context. In the next step an analysis of the building scale is carried out. This includes an investigation of the history and ongoing activations and activators, as well as an outlook on its future development.

To conclude the findings, a force field analysis is carried out, to identify forces in favour of and obstacles towards change of the development of Kniven into a urban Third Place.

## Transects

### From Gothenburg to Partille

Transects were used as a tool to understand and contextualize the relations of the chosen site to its surroundings and further to break down and understand the urban dimension of the context.

A first transect investigates the relation of Partille's broader context, focusing on the relation of Partille to the city of Gothenburg and the adjacent rural areas.

In a second transect a cross section through the

more local context of Partille itself investigates the spatial characteristic within.

Some of the characteristics explored in both transects focus on the density of the areas in terms of built fabric and residents, the prevalent uses and direction of travel for commute and recreation.

The information was gathered through personal observations and study of municipal documents.

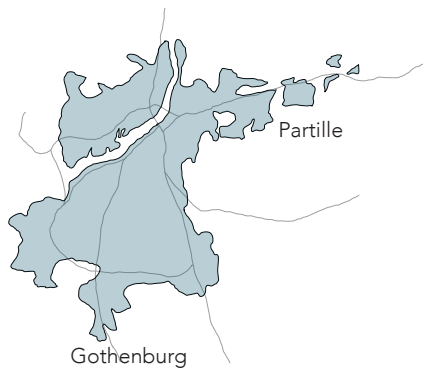

Map indicating the area of transect

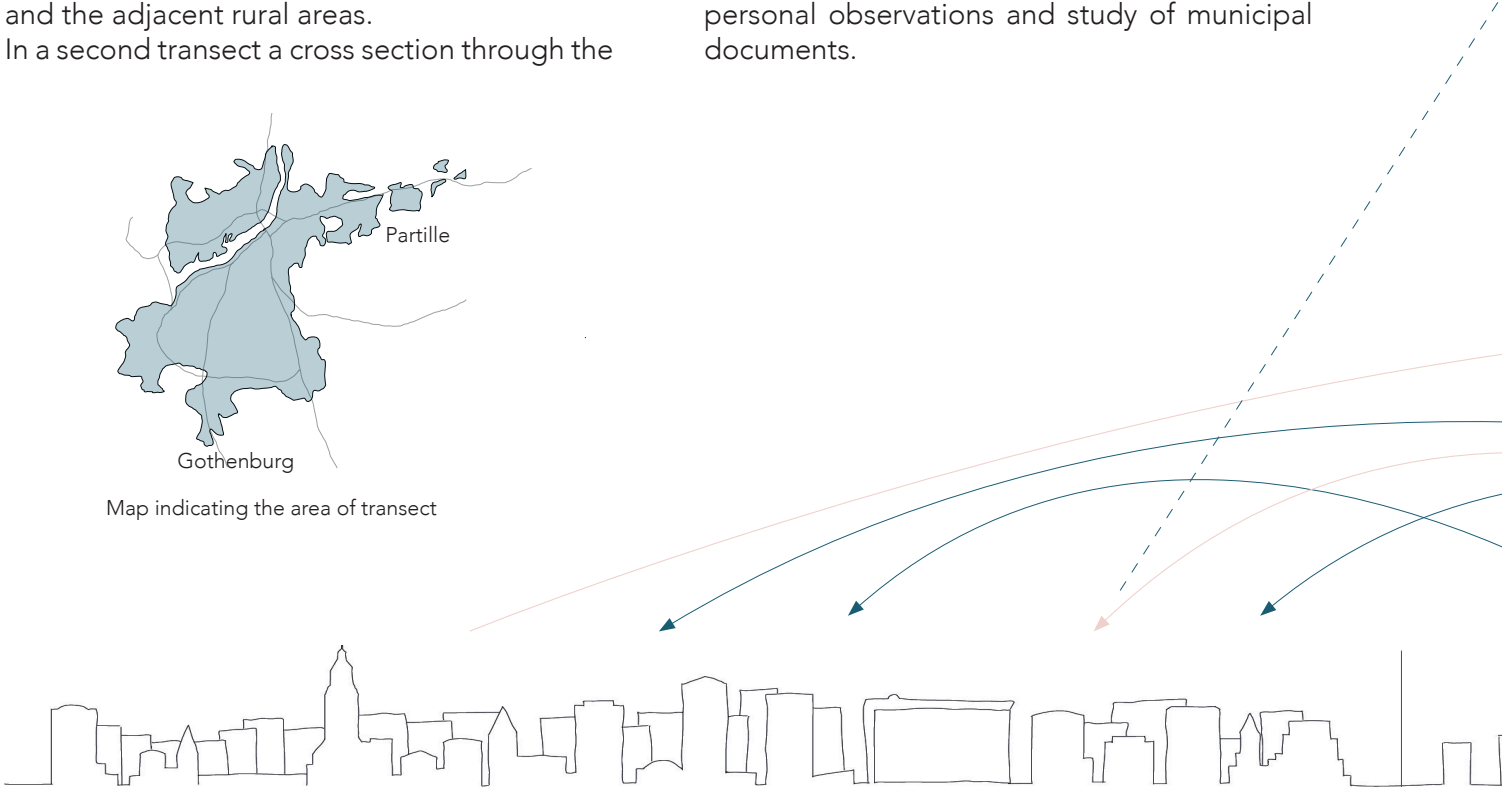

#### Gothenburg City | Urban Zone

##### Characteristics:

- urban

-high density in terms of: population, built fabric (building height and distribution)

-mixed use: availability of variety and choices for commercial, work and leisure facilities; close proximity to destinations

-availability of green areas as recreational zones in city, but always surrounded and influenced by built structure

 density

 commute

 recreational paths



Already today Partille is situated in relative close proximity to Gothenburg.

Through ongoing densification processes in both the urban fringe and Partille, these zones will possibly grow closer together in terms of their spatial relation to each other.

Further this will have effects on the density of those areas in terms of population, for instance it is estimated, that the population of Partille will increase by 15,6 % by 2031. (Befolkningsprognos 2021-2030, n.d.)

This in turn means that potentially many newcomers will come to the area, that are looking for possibilities and incentives to connect with their surrounding community and

neighbourhood - having a third place available in the proximate neighbourhood could positively cater to that need.

As of today, there is an exchange between the different zones, motivated through commute to work from Partille to Gothenburg and its adjacent areas. Additionally there is an exchange for recreational purposes from Partille to Gothenburg (availability and variety of facilities for cultural, social programs) and to the natural areas surrounding Partille. Due to this location and characteristic Partille can be identified as a point for passing through or just living for many of the inhabitants.

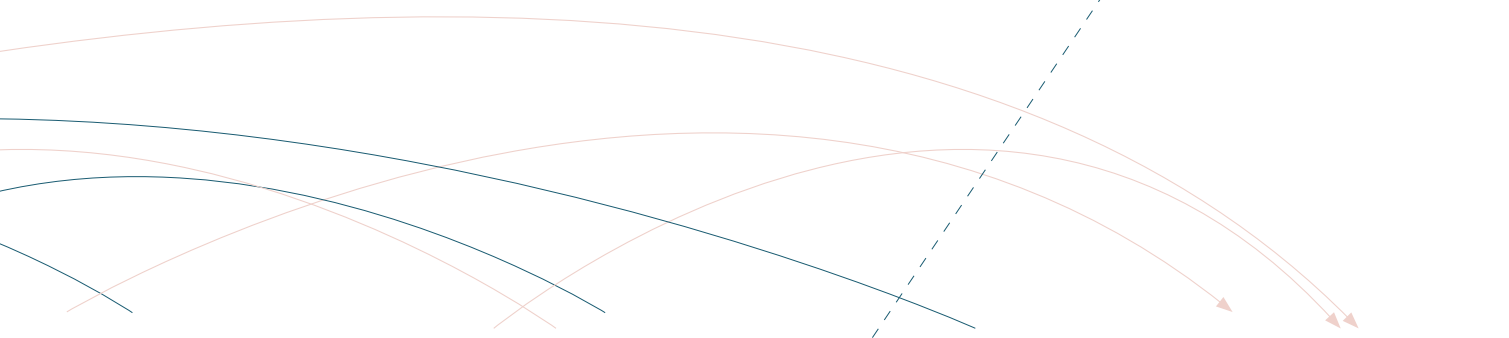



<p><b>Urban Fringe</b></p> <p>Characteristics:</p> <ul style="list-style-type: none"> <li>- lower density than city (decreasing with higher distance to city centre)</li> <li>- division in subzones: living areas (single family and multi-family homes) and more industrial zones</li> <li>- more fragmented built fabric</li> <li>- close proximity to destinations in the city (for leisure) and relative close proximity to natural zones</li> </ul>	<p><b>Partille   Ruban Zone</b></p> <p>Characteristics:</p> <ul style="list-style-type: none"> <li>- medium density (population, built fabric) varies within the subzones in the area</li> <li>- combining elements from urban fringe and rural zone             <ul style="list-style-type: none"> <li>- mixture of multi family homes and single family homes</li> <li>- central square</li> <li>- close proximity to the natural zones</li> </ul> </li> </ul>	<p><b>Rural Zone</b></p> <p>Characteristics:</p> <ul style="list-style-type: none"> <li>- low density (population, built fabric)</li> <li>- mostly low building structures</li> <li>- single family homes</li> <li>- agricultural influences</li> <li>- in close relation to natural zones</li> </ul>	<p><b>Natural Zone:</b></p> <p>Characteristics:</p> <ul style="list-style-type: none"> <li>- very low density both in terms of population and built fabric</li> <li>- nature is the most prevalent element</li> <li>- used as recreational zone by population from other zones</li> </ul>

# Transects

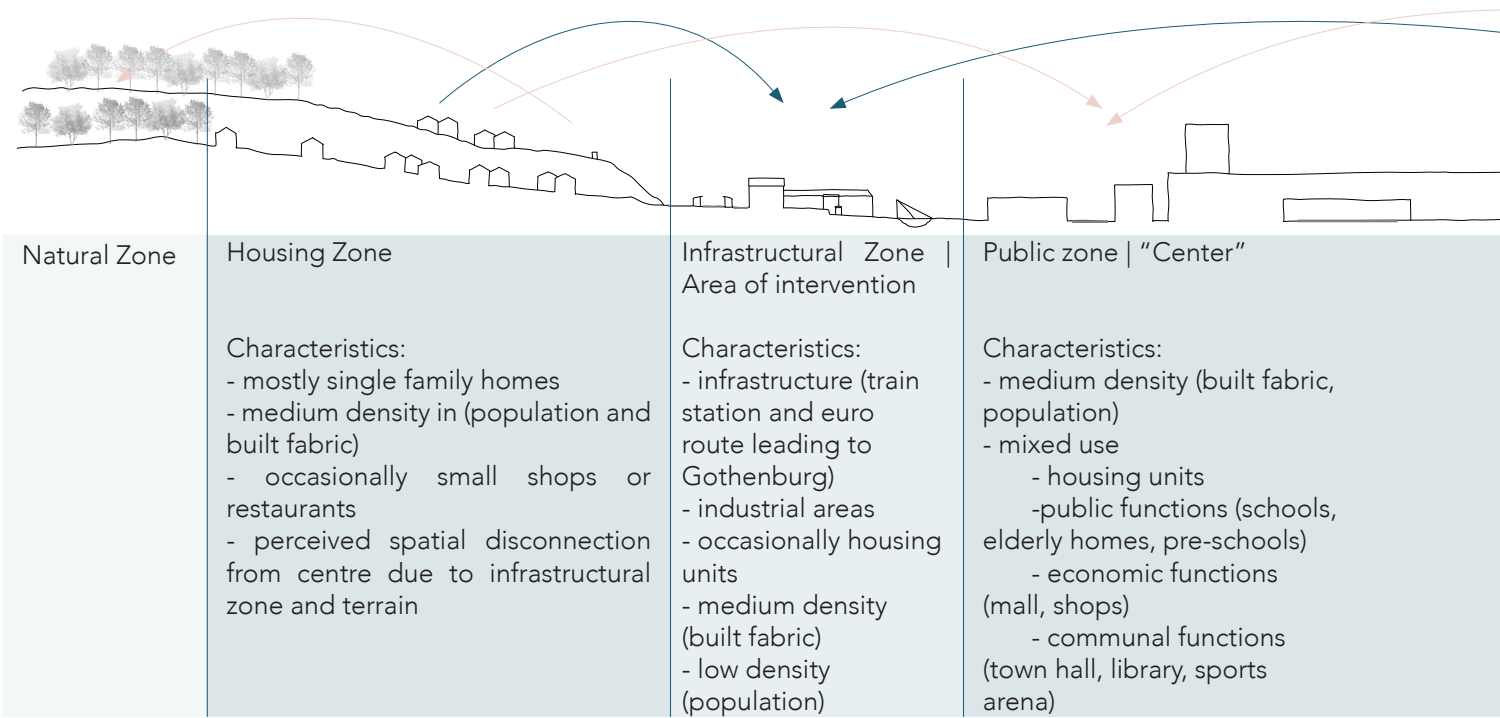
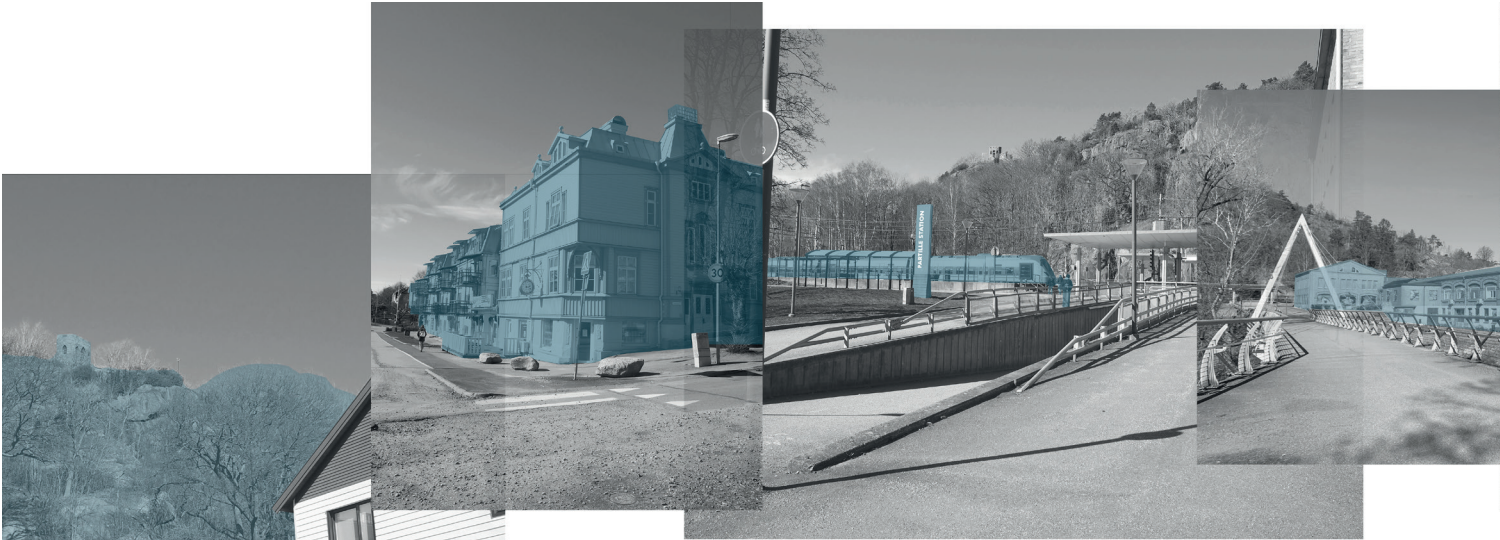
## Rurban Characteristics within Partille



-  density
-  commute
-  recreational paths

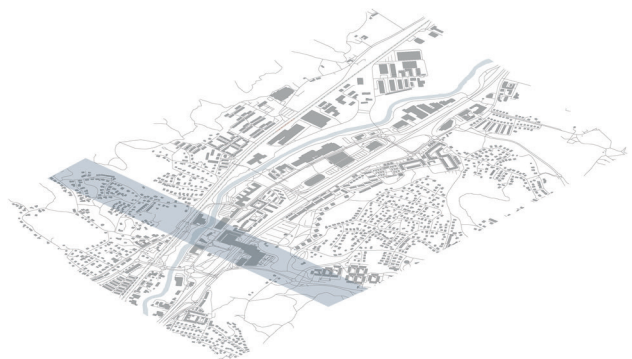

Map indicating the area of transect

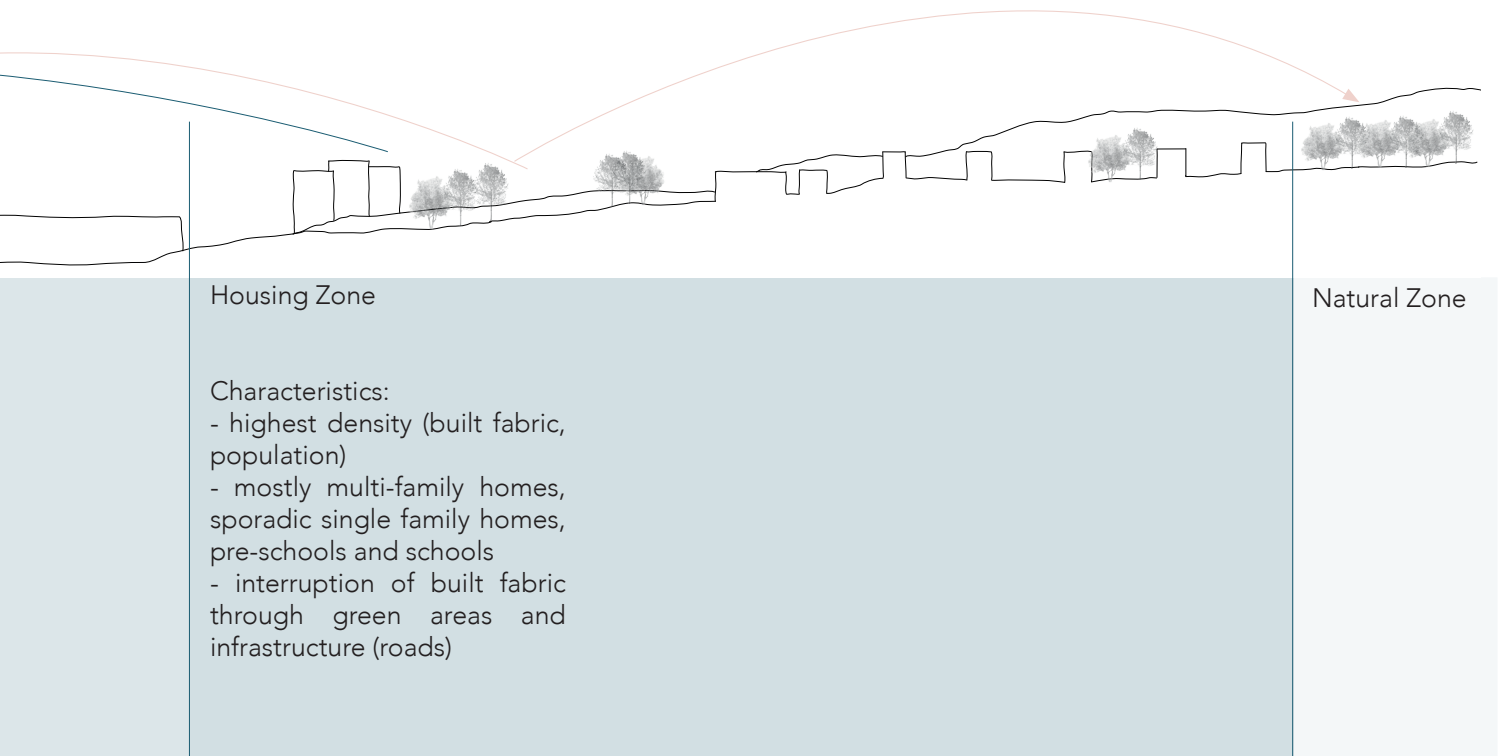

Both references to urban settings, such as concentrated housing facilities and the public square, and references to rural settings, such as the scattered single family homes, interrupted by natural elements can be found in Partille. Through the transect a strong separation of the context into zones can be carried out. This is especially supported through the infrastructural zone separating both the public zone from one of the housing zones and the housing zones from each other. This leads to a disconnect of the existing neighbourhoods, decreasing the possibilities of exchange.

Through its close proximity to both a bigger town and rural areas, as shown in the transects there is an exchange between the different zones, motivated through commute to work from Partille to Gothenburg and its adjacent areas. Additionally there is an exchange for recreational purposes from Partille to Gothenburg because of the bigger availability and variety of facilities for cultural and social program) and to the natural areas surrounding Partille. Due to this location and characteristic Partille can be identified as a point for passing through or just living for many of the inhabitants.



## Spatial Analysis of the Immediate Surroundings - Understanding the Context

To further investigate the spatial dimensions of the immediate surroundings an analysis in maps was carried out. These also support the findings from the transects.

Understanding the (spatial) context in terms of green areas, infrastructure and connections, established facilities, movements and proximities is an important step towards

narrowing down strategies for action and determining potentials for change.

This analysis is a first step towards approaching the chosen area of investigation, Kniven, located in the aforementioned infrastructural zone of Partille.

### Green Areas

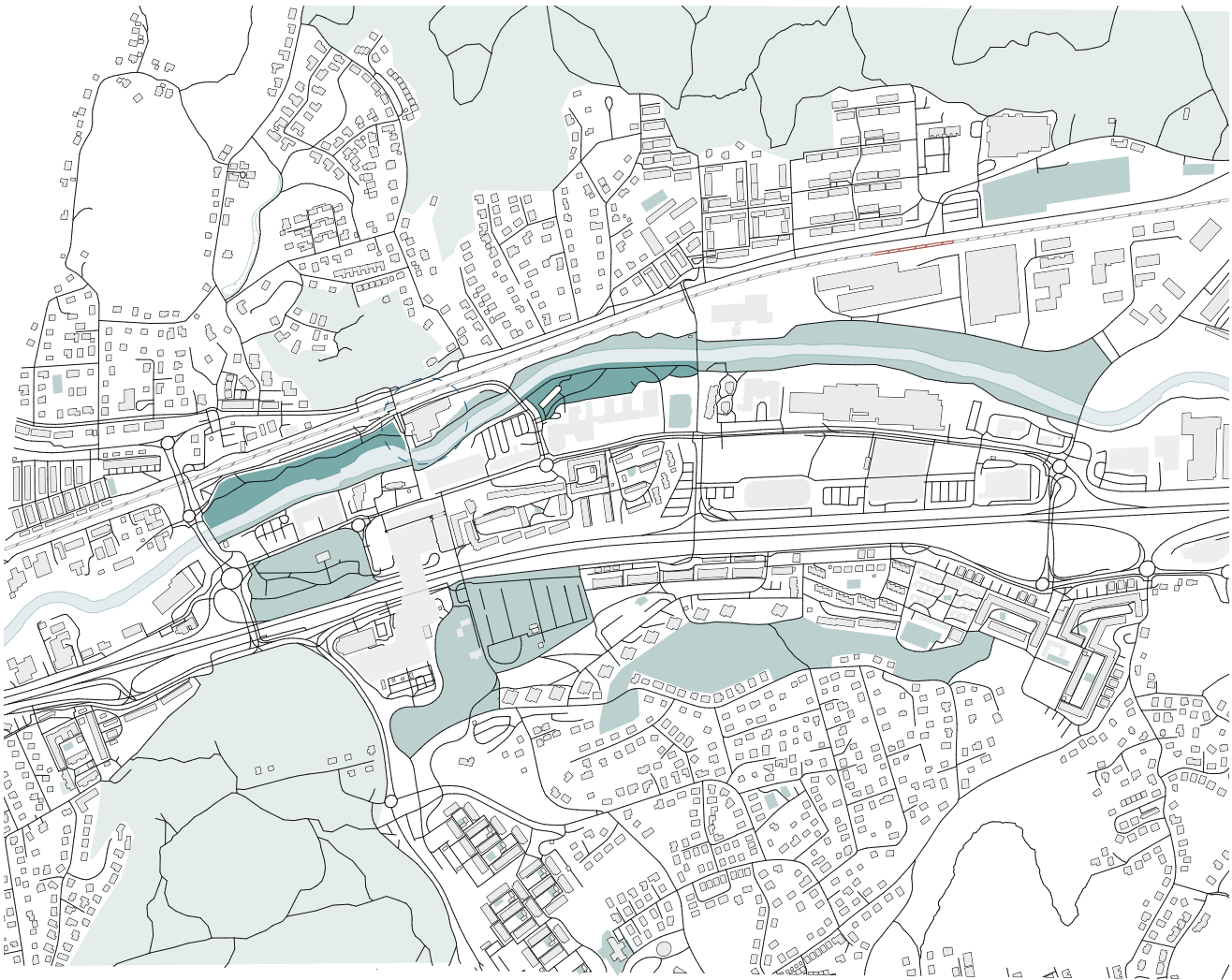

Built Fabric

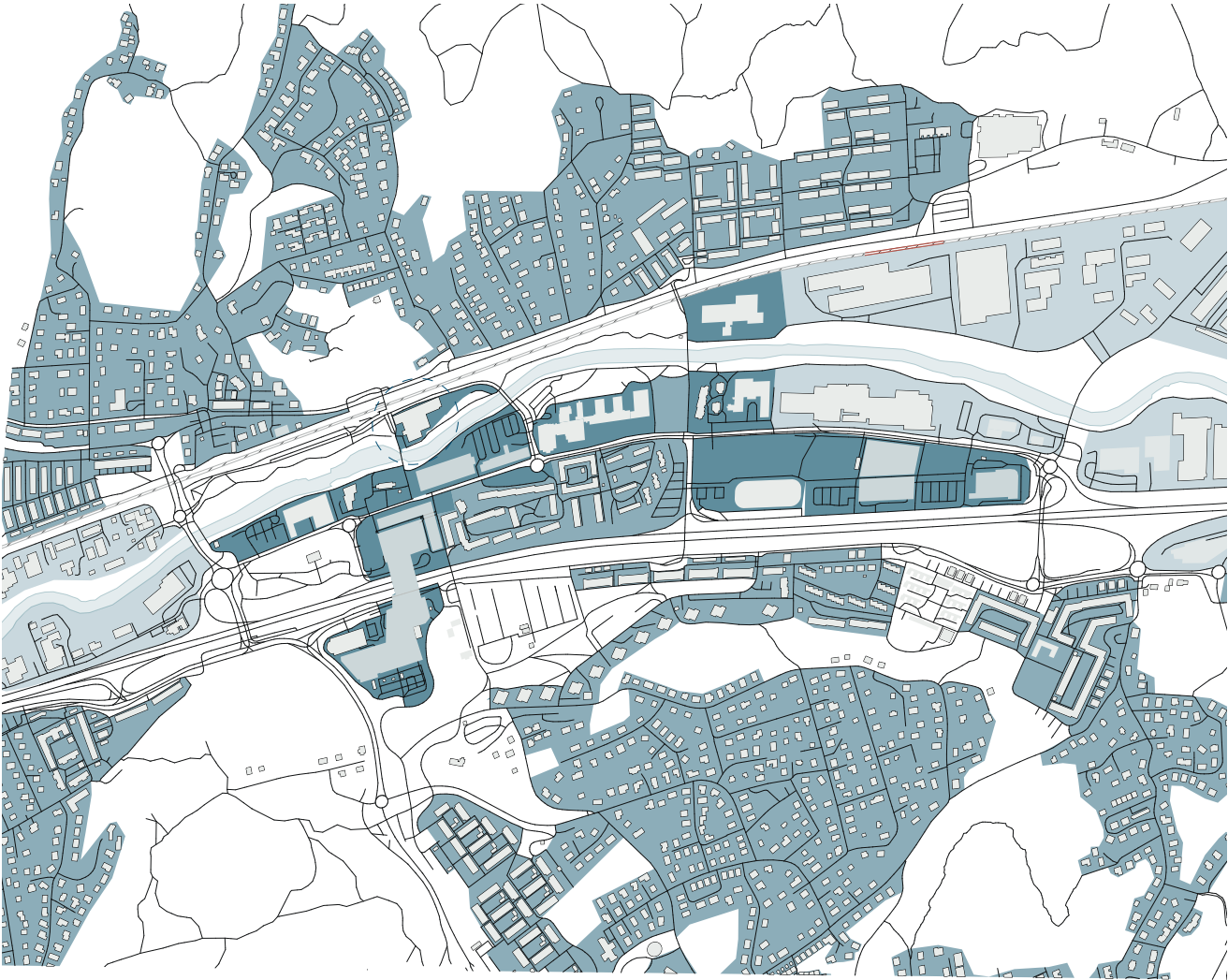

public zones ■  
housing ■  
industry ■

# Functions

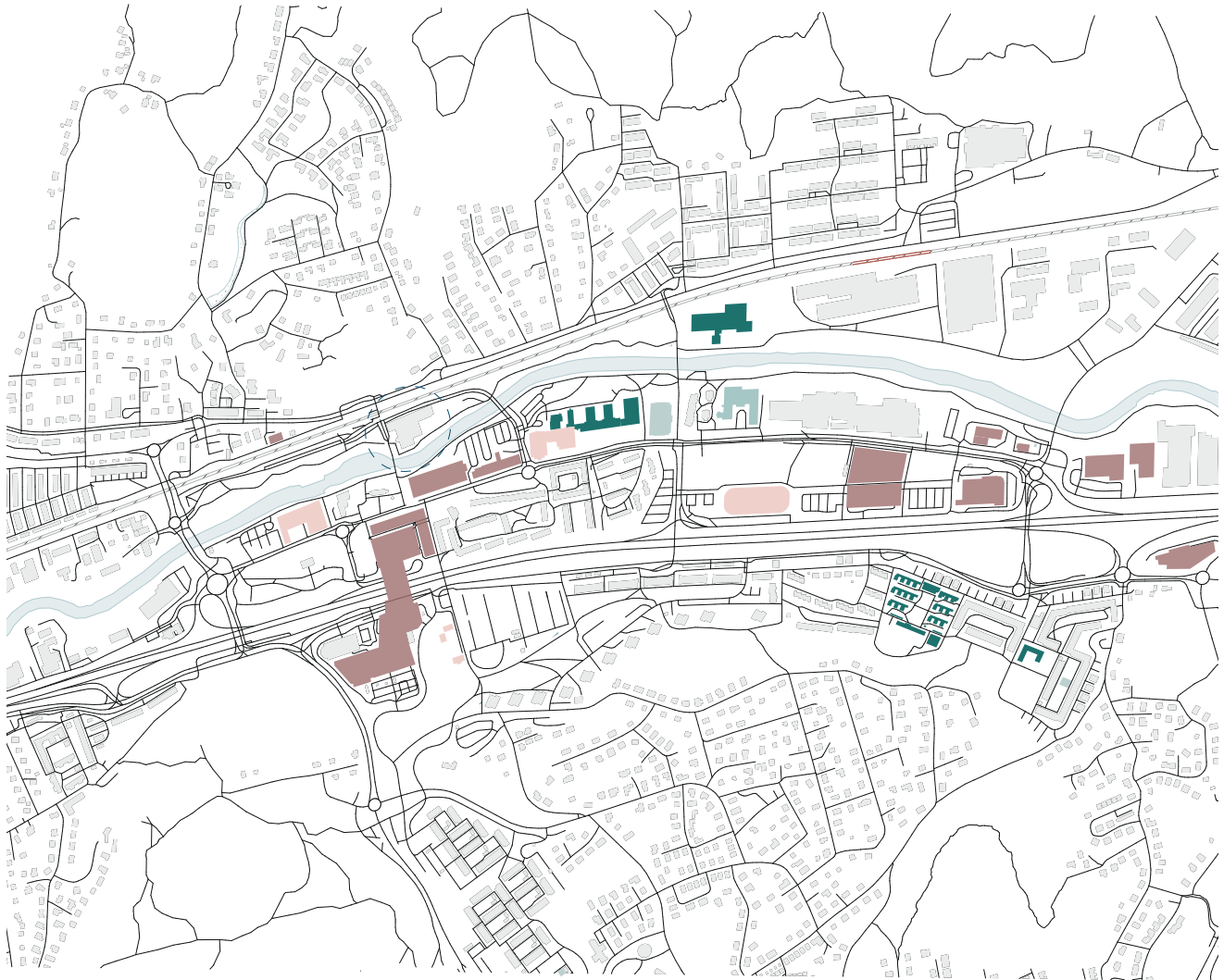

- social institutions
- schools /preschools
- public functions
- economic functions

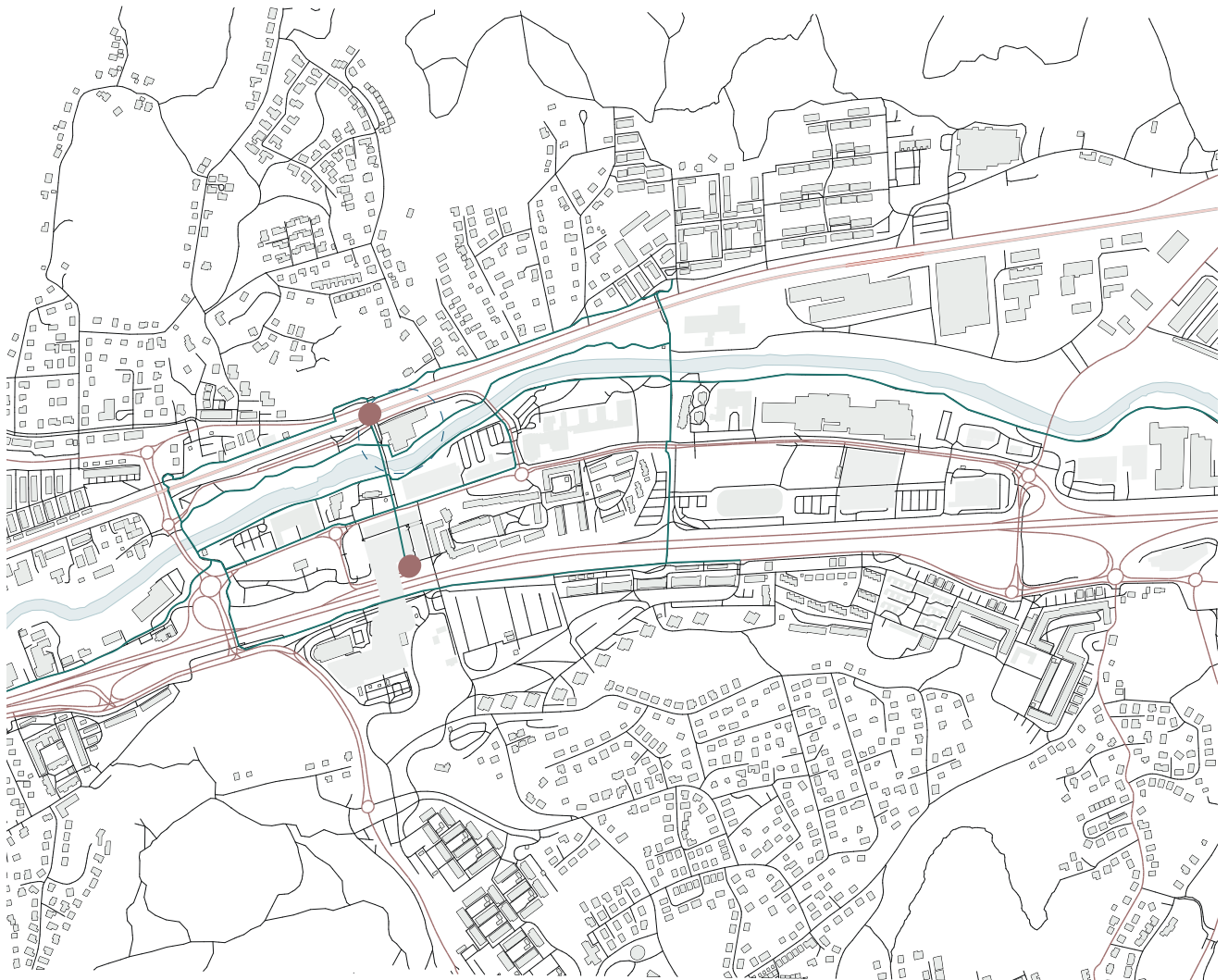

- train —
- main roads —
- bike + walking paths —
- infrastructural hub ●

Here again, a strong separation of the built fabric through the infrastructural zone characterised by the highway, train line and industry becomes visible. A further separating element between the north and south is the river. Kniven is located centrally between the zones and in close relation to the two infrastructural hubs of the area. This means, that it is centrally located along a route that many people, especially commuters, take in their everyday life.

The green areas are mostly dominated by forest like environments, with few public green

areas and parks centrally located, but mostly unprogrammed.

As of today, there is little variety in meeting spaces. To increase their variety and availability further is a goal set by the municipality in their overall plans for future development. (Målbild Partille Centrum 2035, n.d.)



## Third Place Mapping and Investigating Relations

The implementation of a new Third Place in Partille will have impacts on the already existing places that are perceived as Third Places. To be able to discuss these effects, a mapping of the existing Third Places in the area was carried out.

In their works Jeffres et.al. (2009) provide the reader with an extended list of types of Third Places based on four different categories of activities: "Eating, Drinking and Talking", "Organized activities", "Outside Venues" and "Commercial venues".

Places which fall under these categories were identified and documented.

These include socio-cultural places such as libraries and culture halls, commercial spaces such as the mall, restaurants and cafés, but also youth- and sports facilities.

Facilities that could later be put in relation to and be influenced by the implementation of Kniven as a third place (negative positive ?) are specifically highlighted and then transferred into a network, that will later be introduced in the reflection of the thesis work to discuss the facilities impact on the surroundings.

In the context of analysing the existing Third Places in Partille through the categories defined by Jeffres et.al (2009), it became evident, that most of the places available today fall under the category "commercial venues, as well as "drinking, eating & talking", which further require consumption to some extent to engage in the place.

The few places that do not fall under these categories are the local library, that also houses a maker-space and kulturrum, the youth centre and additionally the public main square and public parks. An other observation

that can be made, is that these existing places are mostly concentrated south of the river, potentially meaning a disconnect between the engagement in those places from residents living in the northern part of Partille.

These observations lead to the conclusion, that a Third Place is needed in the area, that enables both more engagement from the whole community, but also engagement without necessary consumption. Further, a variety of activities to engage in are needed, to expand the existing programs in the area.

Currently there is no strong connection between the different places and their functions. Further, actors that could be included to create possibilities for exchange between the places and create incentives for engagement are only included to some extent.

The insertion of a new type of Third Place in Partille could have positive impacts on strengthening and building connections, leading to an exchange between the different neighbourhoods and thus a reconnection of the built environment. A stronger network between the places should be strived for.

## Third Place Mapping

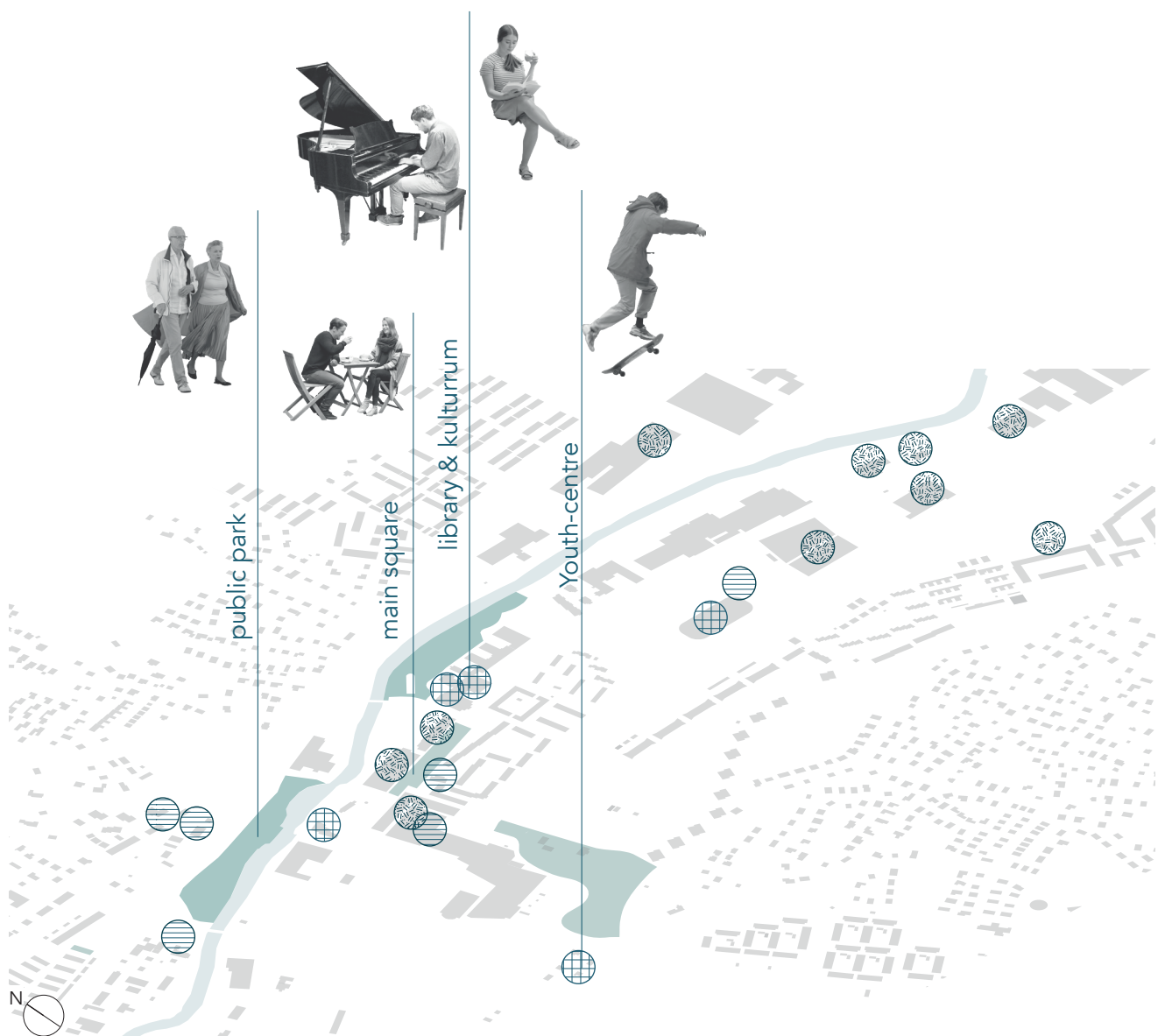

"Eating, Drinking & Talking"  
 bars, cafés, restaurants

"Organized activities"  
 churches, organizations, clubs, libraries, sports

"Outside Venues"  
 parks (with sojourn qualities), public squares

"Commercial venues"  
 shopping centres, shops, markets (examples)

# Kniven Today - Understanding the Ongoing Activators

In order to further situate the project in the current context, it is essential to understand which activators are currently involved on the site and performing in the space. This serves as a basis for identifying potential users and uses, as well as creating a further basis for discussion on the relevance of the project in the context of current and planned developments.

The information was gathered from official documents, own observations and informal conversations with actors on and off site. In the following diagram, the current actors are characterised and related to each other in order to show mutual influences.

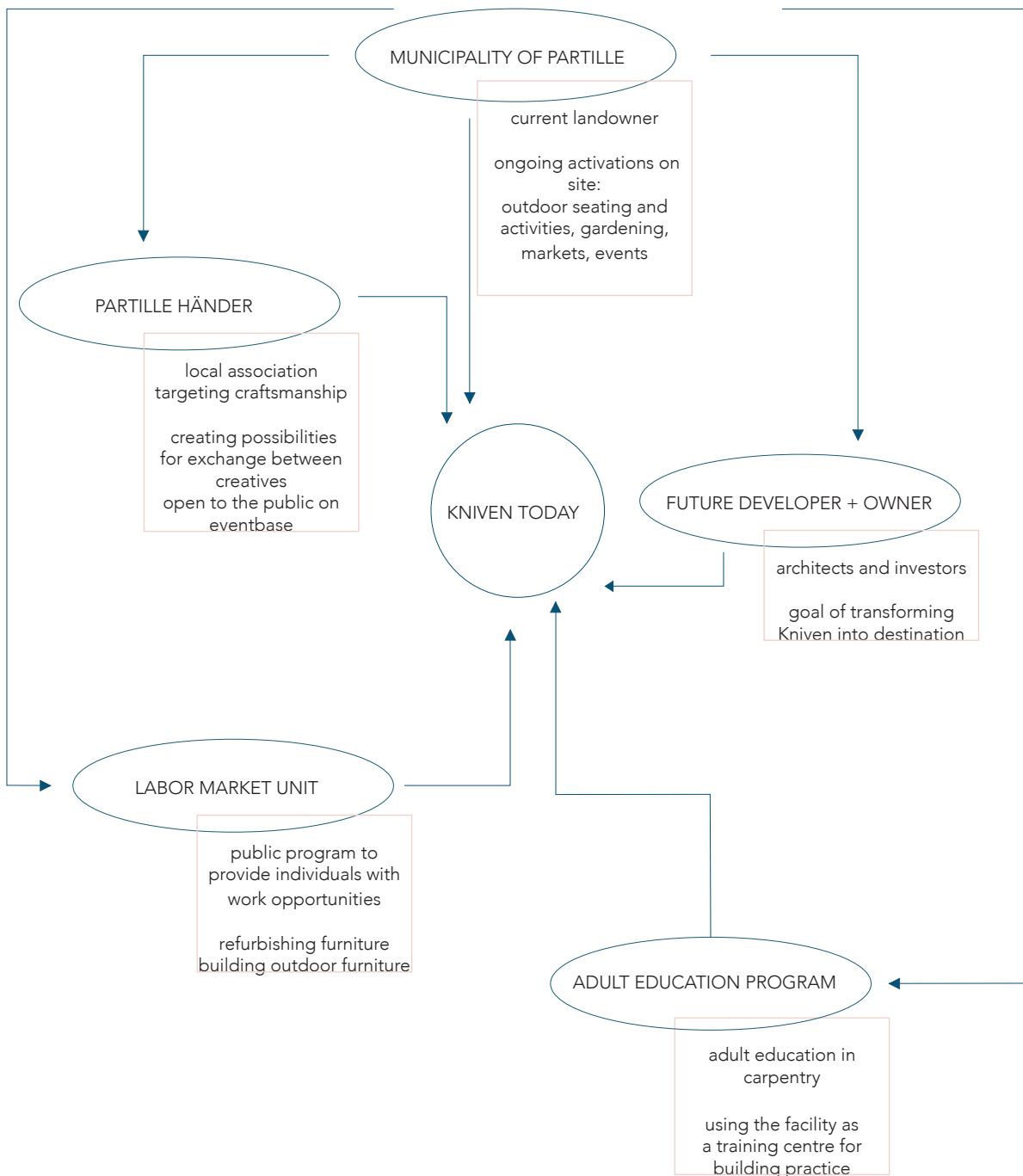



## Force Field Analysis - Understanding Forces for and against Change

Based on the previous analyses, a force field analysis was carried out. This compares driving and restraining factors in order to identify potentials and starting points for further project development.

Factors from the spatial analysis, the analysis of existing and future actors, economic factors as well as the needs of potential users and aspects of Third Places are taken into account.

It is important to note that the classification of

the factors is partly subjective and the individual elements could be assessed differently depending on the point of view taken.

Based on this force-field-analysis potentials for action can be identified. These could either strengthen the driving forces and counteract the restraining factors.

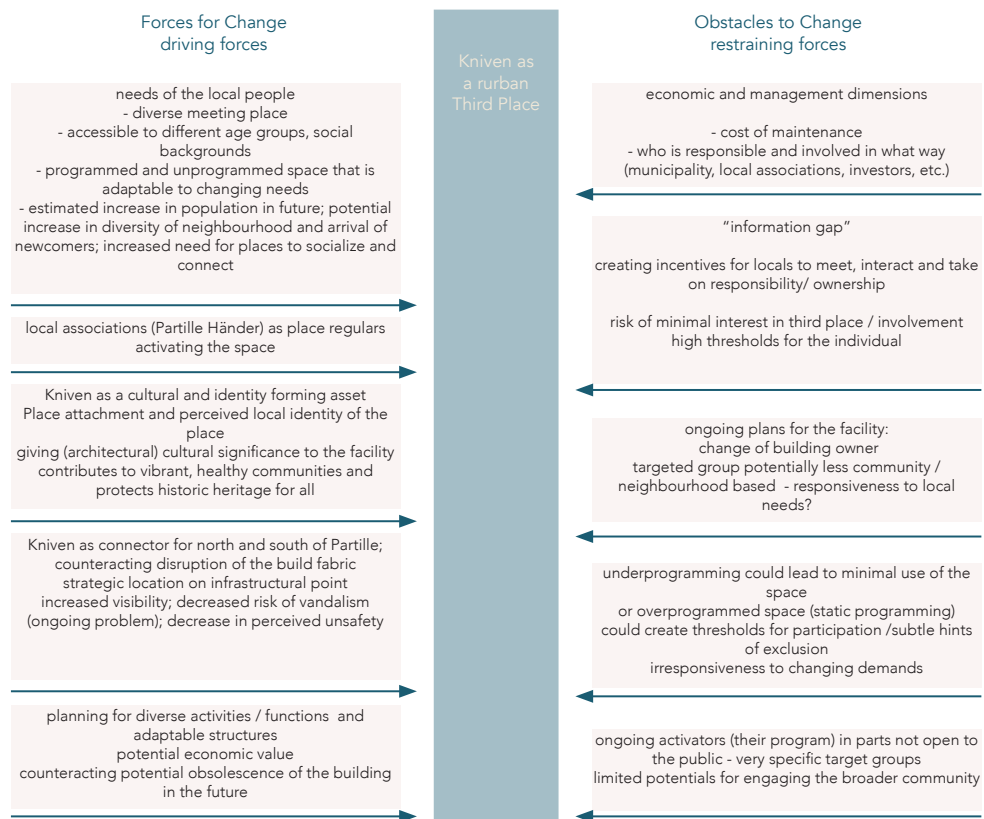

### Conclusions

- finding stakeholders to take active part in development and management of the place
- finding ways to communicate the facility with potential users; through architectural interventions; orientation of the program;
- changing the orientation of the existing activators to be more open to the local public; engage stakeholders/ actors in community based projects
- programming the space/facility in a way, that different stakeholders (with economic) assets can and will take part: incorporating functions that could create economic revenue (finding a good balance between "consumption based" and "community based" functions)
- counteracting static programming: leaving space in the program for spontaneity and adaptability; flexibility of use
- finding balance between programmed and unprogrammed space
- identifying and working with the local needs to create interest and motivation to interact with the space
- identifying needs of different potential user groups; narrowing down functions and program based on the local interests
- enabling use over different times of the day: creating accessible indoor and outdoor environments, that can be freely used throughout the day by anyone; working with place regulars that activate the space throughout different times of the week, month, year

## Narrowing Down the Site - Analysis on Building Scale

The chosen site for further explorations within the thesis is a former electrical factory, that is currently mostly vacant and awaiting transformation into a new destination for Partille. The building and its surrounding are called "Kniven" (the knife).

For the time being, the municipality of Partille is the owner of the facility and has started to activate the area through outdoor place making interventions such as benches, boules fields and planters that can be used freely by the residents and community. These installations were constructed and are managed by the municipality in cooperation with participants of the labour market unit.

Part of the facility is currently rented out to a craftsmanship association, that occasionally opens up for the public. The local adult education program in carpentry is using the facility as a training center, helping out with small scale renovations and alterations of the facility, to adapt it to the needs of the current users.

On occasions, markets and community events take place in the outdoor area surrounding the facility.

Due to its location between the infrastructural nodes and along green areas, the facility is seen as a building with great value for future development.

The history of the building, as well as the ongoing activations can be further built upon and used as a starting point, to create a sense of belonging for the community and implement a third place, that enables residents to meet and encounter.

### Impressions from the site



Movement + outdoor activations

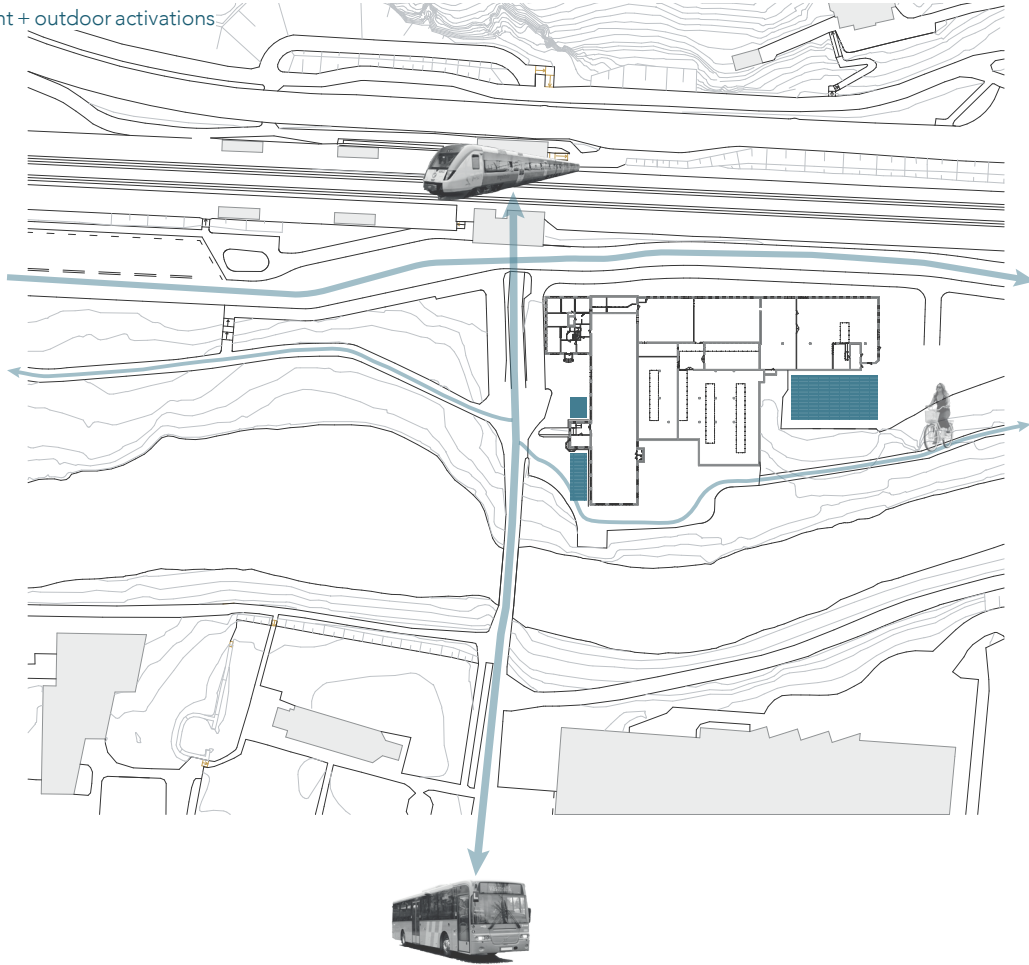

entrances

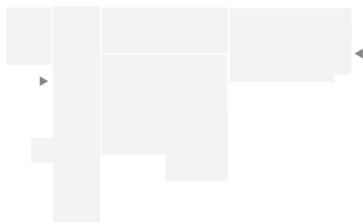

building condition

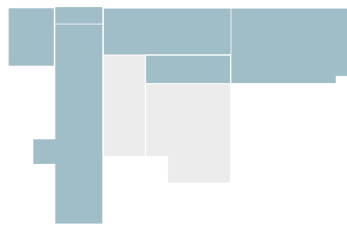

- good condition
- bad condition

current use

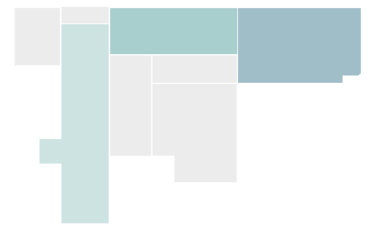

- craftsmanship association
- labor market unit
- adult education
- not in use

exposure to noise and traffic

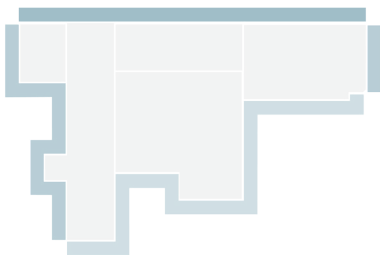

high low

proximity to green areas

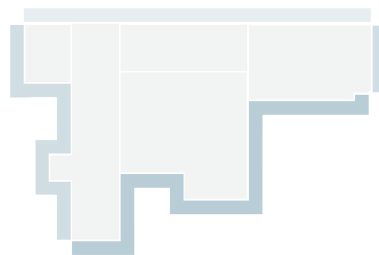

high low



## Setting the Ground for Design

Based on the findings of the previous chapters, the foundation for the design will be set.

Potential users are identified and then narrowed down to specific user groups, whose perspective on interaction with the place will later be taken on.

Further activities and functions, as a result of the previous explorations, are mapped. This helps to later define the spatial organization, that can enable a Third Place.

As a last step, the findings of the chapters before will be concluded and transferred into design strategies, which are later applied onto the building.

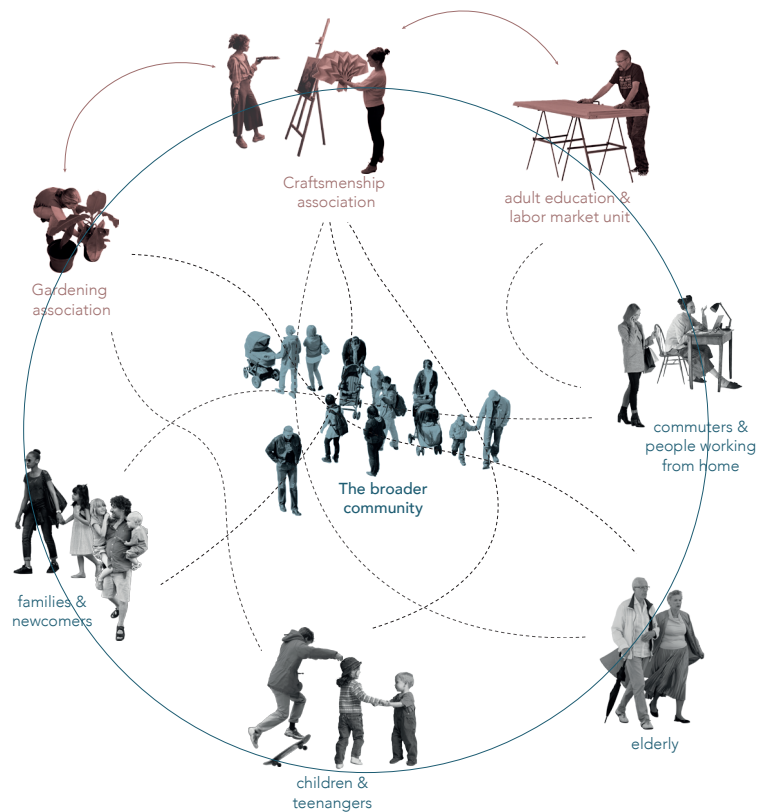

## CUI BONO? Narrowing Down the Users

Based on information gathered from different sources, such as informal interviews and municipal documents, as well as the analysis of ongoing activators, potential user groups were identified. A broader analysis of different groups and individuals was carried out and narrowed down to different user groups, whose perspective was taken on in the scope of the thesis, to develop a program and test out the design ideas. Some of these users and their characteristics are described below. (For more detailed user profiles, including needs and wants, see appendix)

Partille as a Rurban area in the periphery of Gothenburg is constantly growing, with new people moving in and the built area changing in the next years. This development makes it necessary to install places to not only create and enhance community connection, but to also make use of existing facilities, that the residents feel a connection to place attachment. In turn this can contribute to welcoming newcomers and provide them with chances for encounter and possibilities to connect to the existing community.

In the light of this development, with their numbers increasing as well, it is further important to consider children and teenagers as a crucial target group. Municipal documents imply, that there are currently very few places

in Partille that could be seen as leisure and meeting points for them.

Statistics from the municipality further state, that there is a large number of residents commuting from and to Partille on a daily basis. Additionally there is a trend towards the merging of the first (home) and second (work) place. People working from home and commuting are looking for places to socialize and connect during the week, and disconnect from the rigidity of the workplace on the weekend. Through that, they become an interesting target group with a variety of needs that could be addressed in a Third Place.

Since the project has its starting point in the transformation of an existing facility, that is currently activated with meanwhile uses, it is further relevant to consider ongoing activators, that could contribute to people's place connection.

As mentioned in the theoretical framework, socio-cultural functions can play an important role in rendering third places successful, since they can attract various groups of people.

The craftsmanship association "Partille händer" is one of the current users of the facility, on a regular basis, they open up for the public, with exhibitions and workshop. Through that, they become a valuable asset in the transformation of Kniven into a Third Place.

"intangible" (activities) Observations from Public spaces	ongoing functions at Kniven	planned functions (architects, västprojekt)	Functions usually found in community centers (from "case studies")
people watching	reuse / refurbishment of Furniture through labor market unit	Hotel	sports / recreation area (indoors and outdoors)
meeting	↓	conferences	libraries
interaction [greeting, conversations, spontaneous	exterior furniture (seating, boule courts,...)	conferences	nursery
strolling	second hand clothes through church organisation (for economically disadvantaged)	gin distillery	eventlocations (concerts, weddings, public gatherings)
waiting	adult education in carpentry (through municipality)	Cafe / Restaurant	learning opportunities (skill sharing, classes, repair cafe, etc.)
walking towards destination	Craftsmanship association	studios	sanctuaries / religious facilities
resting [observing surroundings, reading, lingering]		eventlocation	cafes
		offices	community services

## Setting the Ground for the Program

To narrow down, which kind of functions and activities could happen and take place in Kniven as a third place, a juxtaposition of different functions was carried out. Tangible and intangible activities were considered.

Further ongoing activations as a starting point for future development, planned functions for the development of the facility and functions usually found in community buildings were gathered and examined in regards to their applicability of the context. In addition the four dimensions dimensions of activities usually linked to and carried out in Third Places, set Jeffres et.al. (2009) ("eating, drinking, talking", organized activities", outside venues" and commercial venues") will be taken into account when setting the program.

As an outcome of this investigation, the thesis proposes for Kniven to have layers of indoor and outdoor areas, that offer a variety of programmed and unprogrammed spaces. This will allow for the community to take part in planned activities, but also take ownership of the place and programme it themselves, thus increasing the sense of belonging.

It is further proposed to take into account socio-cultural as well as association and economic dimensions.

Based on these considerations, a mixed-

use programme is proposed, which makes it possible to address different user groups. Such a mix of uses can also create new meeting spaces and points of reference for the spatial design of a Third Place.

The proposed functions are not to be seen as a rigid programme, but rather a starting point and framework for investigating how people's encounter could be enhanced through a built space. Additionally, it is important to keep in mind, that the needs of the community as well as the individual might change over time, and their demands towards a meeting space might simultaneously change as well.

Therefore the place needs to be able to adapt to those changes.



# Design Principles

The findings from the previous investigations in regards to the theory, context and users are translated into design principles.

They are linked to the Third Place principles set earlier in the process and further connect back to challenges for the community, that will be addressed through the implementation of a Third Place in the context of Partille.

The design and third place principles further guided the design development.

In the following process, the application of these principles is reflected upon, in order to be able to conclude the thesis with a discussion of the research question.

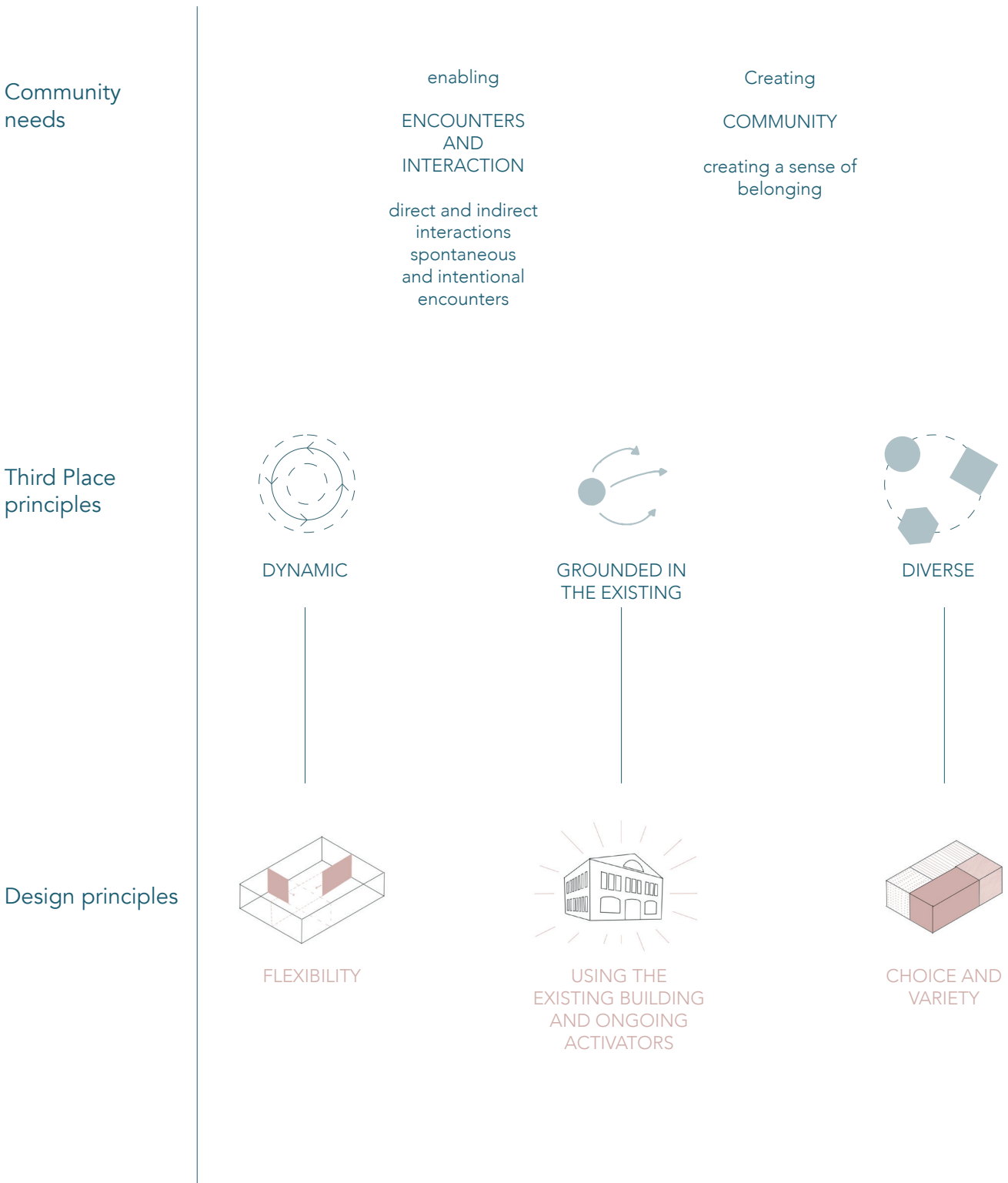

Creating  
CONNECTIONS  
creating a sense of  
enjoyment

enabling  
AWARENESS,  
INTERACTIVITY  
and PLACE  
ATTACHMENT

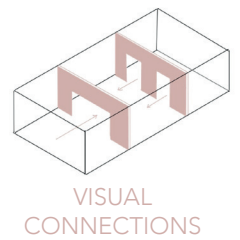
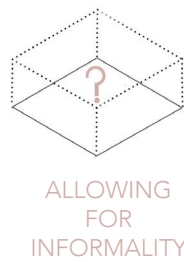
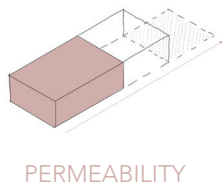
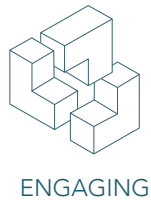



## Design Explorations

The design is carried out through different explorations to approach the discussion of the research question.

These illustrations show how the findings from the previous studies can be applied to the building and how the previously defined design principles can be integrated in the specific context of an existing building in Partille. Further this will explore how the design can enable and promote the interaction between users.

Each exploration is summarized in takeaways, to be able to reflect on the research question and discuss, how the notion of a Third Place can be approached in the context.

## Spatial organisation

In response to the contextual analysis, and the set ground for the design a spatial organisation is carried out. This entails an activity mapping as well as the exploration of spatial categories. These are then transferred into a spatial arrangement on site.

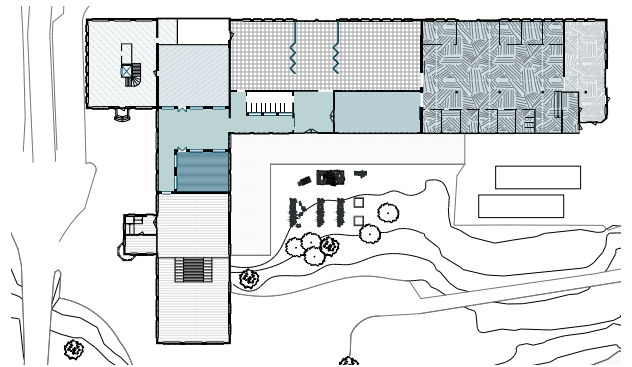

## Building elements to enable a third place:

Building elements are proposed for the existing building that allow for different types of uses and interactions. These include immobile and flexible structures.

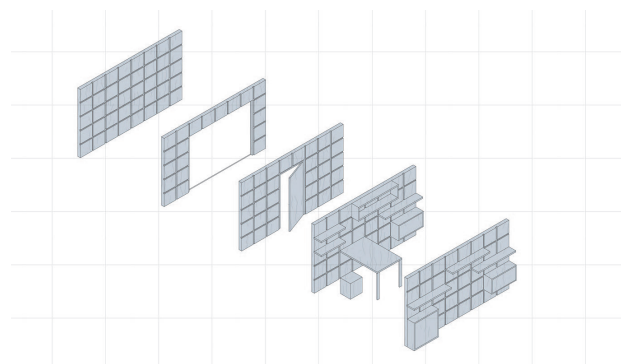

## Creating a narrative through collages and sketches:

Through collages and sketches the set program and building elements are explored with the added lens of the users. This narrative is build up on the understanding of place as the sum of interactions happening within it.



## Comprehensive synthetic axonometric view:

An axonometric view concludes the design chapter and brings together functions, structural elements and interactions in a final scenario in the specific context of the existing building frame of Kniven.





## Spatial organization

### Activity Mapping

Based on the findings from the previous chapters, an activity mapping and function mapping is carried out.

The project proposes to incorporate functions based on a mixture of association + commercial based, outdoor programming, socio-cultural programming and community and leisure based programming. Considering these dimensions, ensures that different interests can be followed, and actors be provided with opportunities to navigate and active the place.

These proposed programs allow for different activities to happen in parallel and succession of each other another enables ongoing and new users to make use of the place according to their needs. The activity mapping refers back to the findings from both the theoretical and contextual analysis, proposing functions that are currently missing in the area. The program is to be seen as a starting point for further development through users. Providing a variety of functions provides users with choice over activities that they want to engage in. Exchange between different programs is promoted.

The activity mapping refers back to the findings from both the theoretical and contextual analysis, proposing functions that are currently missing in the area, can enable ongoing activators as attractors to the facility and provide a variety in possible encounters to happen.

A cafe in relation to the train station is proposed as an attractor and regular meeting spot to the facility.

Co-Working areas provide users with the opportunity to socialize while working.

The proposed community hall enables socio-

cultural functions (concerts, theatre, etc.) and community events to happen, both also in relation to the already existing Kulturrum.

The reading- and playroom creates a link to the existing library in the area and provides individuals with a more calm environment to detach from their everyday live individually.

The community kitchen in relation with the gardening provides users with the opportunity to gather around activities such as cooking and eating and further provides opportunities to learn from and teach each other.

The Greenhouse serves as a connector to the garden as well as the Studio and can be used for a variety of activities, for example as a workshop from by the craftsmanship association. It further creates a relaxing environment in relation to the outdoors, that enables a connection to nature during all times of the year.

The studios provide space for the craftsmanship association to continue their program and further enable creative exchange.

A flexroom can be used for a variety of different activities, allowing for informal gatherings and for the users to take ownership through inserting their own programs. These could among others include sports events, markets and exhibitions.

The garden creates an engaging outdoor environment and connects different activities. In cooperation with the existing gardening association of Jonsered, this area becomes activated.

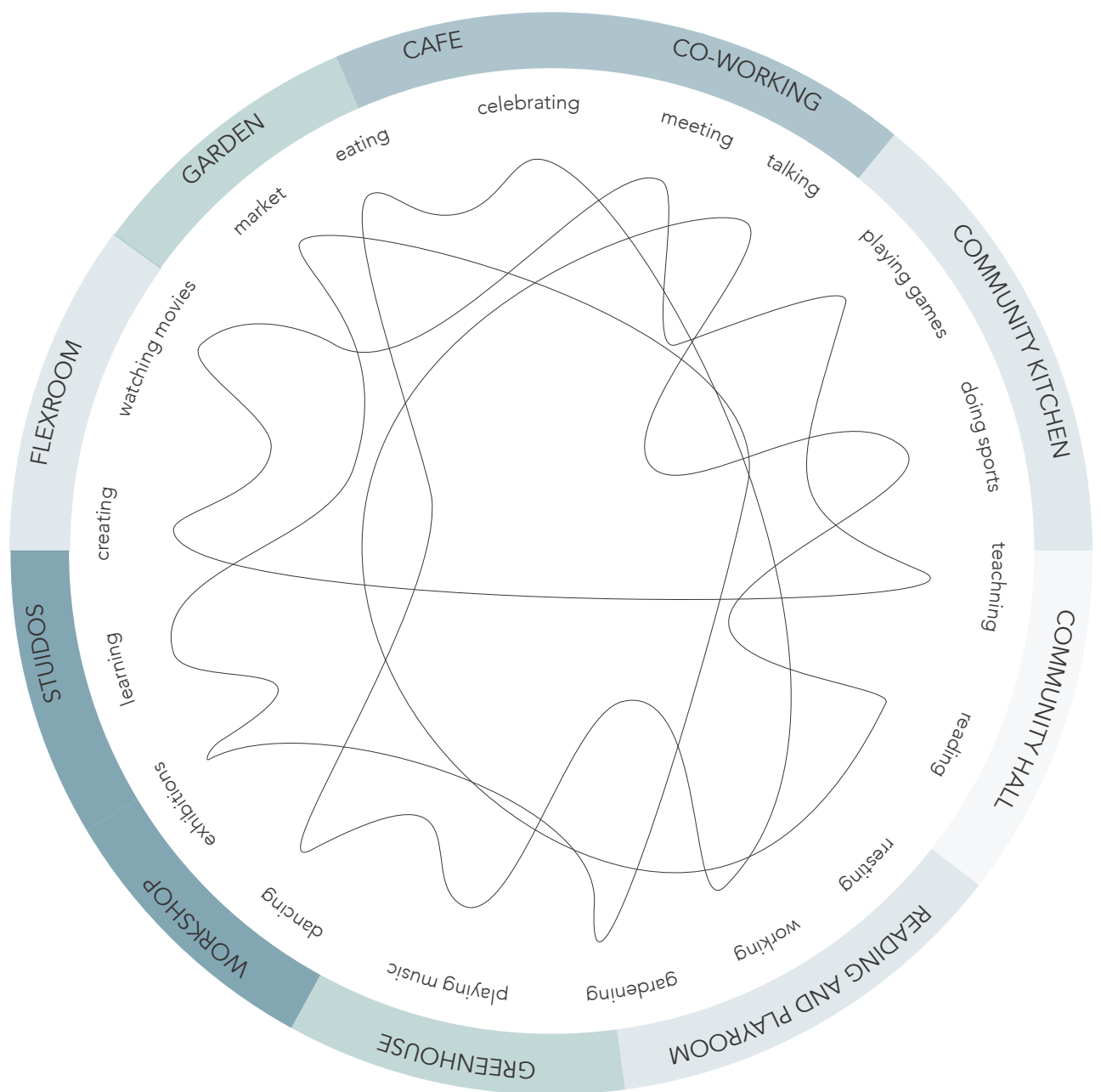

- socio-cultural programming
- (semi-) outdoor programming
- commercial based programming
- community- and leisure based programming
- association based programming

# Spatial organization

## Spatial Categories

As a reaction to the design principles of "allowing for informality" and "choice and variety" the project proposes to insert the before set program in sequences of rotational and fixed spaces. These two spatial categories are overlaid with the category of being shared or divided, whereby these categories can also coincide with each other. This allows for users to choose between

different levels of engagement that they want to participate in and further enables possibilities to adapt their surroundings to their needs.

The spatial categories are assigned to the proposed functions and arranged in relation to each other in the context of the existing building.

Rotational Spaces

vs.

Fixed Spaces

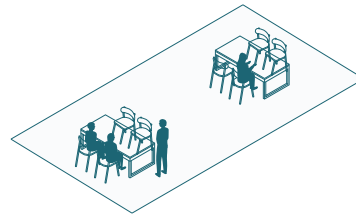
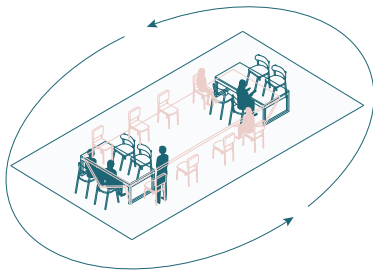

### WHAT defines the space?

space that stays mostly the same (in terms of furnishing, floorplan, etc.)

space with a set function

appropriated differently by the users

used by different users for the same or similar activities

used by different users during different times of days / week

### HOW do encounters happen?

meeting primarily in ones own group (meeting friends, family, colleagues) > intentional meetings

space creates incentives to stop by and interact with the third place

still potential to meet across groups > unintentional/spontaneous encounters (depending on programming)

intentional and spontaneous encounters can happen

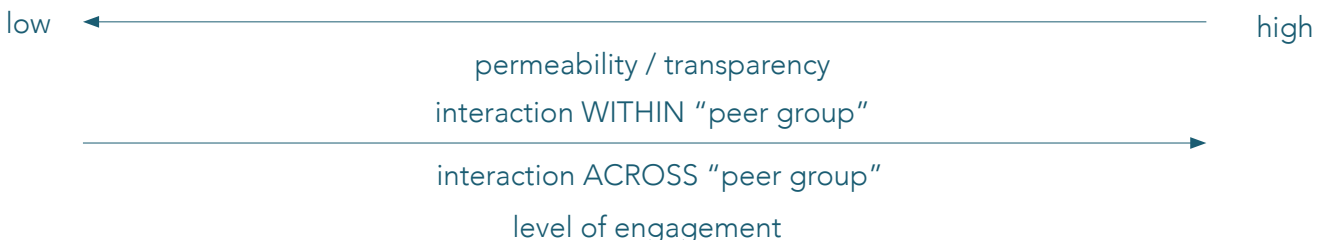

Divided Spaces

vs.

Shared Spaces

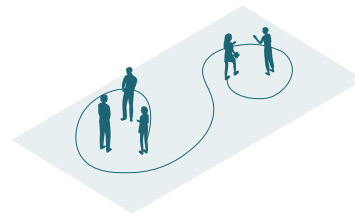
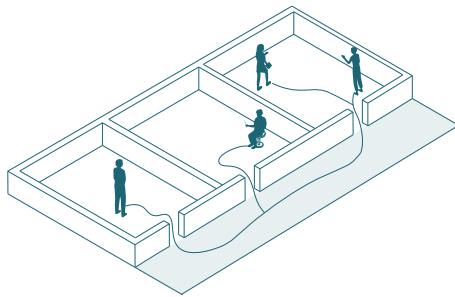

WHAT defines the space?

same build area / frame but space (permanently) divided in different areas

space that is programmed with different users simultaneously

things happen in parallel but separate from each other

no clear boundaries, high in flexibility and permeability

HOW do encounters happen?

intentional encounters in the space could happen

high chances for encounter and exchange spontaneous and intentional

Spontaneous encounters creating interest and curiosity

visual and audio connections > permeability

strong visual and audio connections - high flexibility

low



high

permeability / transparency

interaction WITHIN "peer group"



interaction ACROSS "peer group"

level of engagement



## Spatial organization

# Connecting Activities and Spatial Categories

The spatial categories are linked to the before set program and potential activities.

There spatial connection to each other, as well as potential programmatic links are mapped out.

The program is not to be seen as a rigid concept, but rather a starting point for the third place, enabling different activities to be implemented through the users in the future.

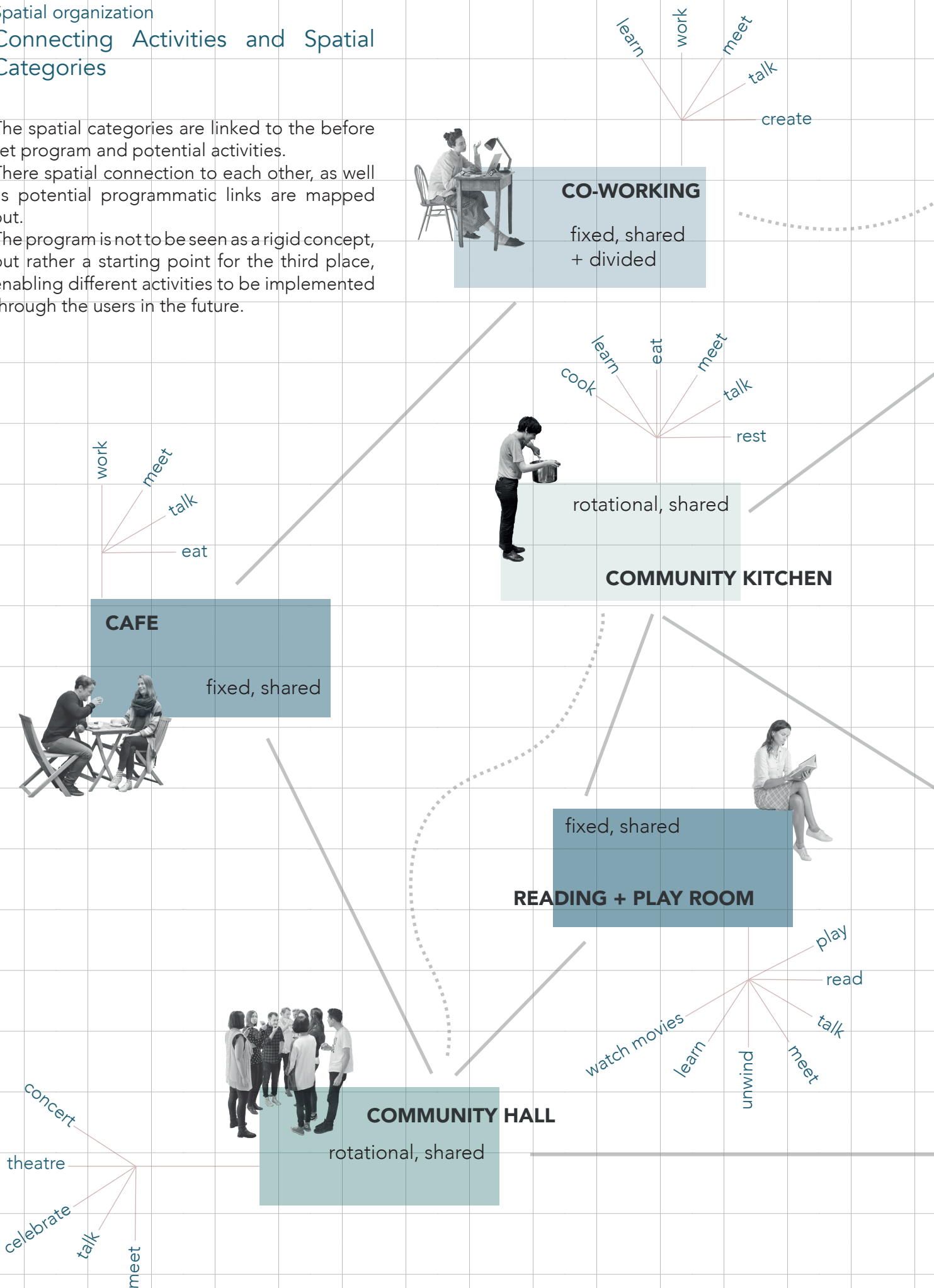

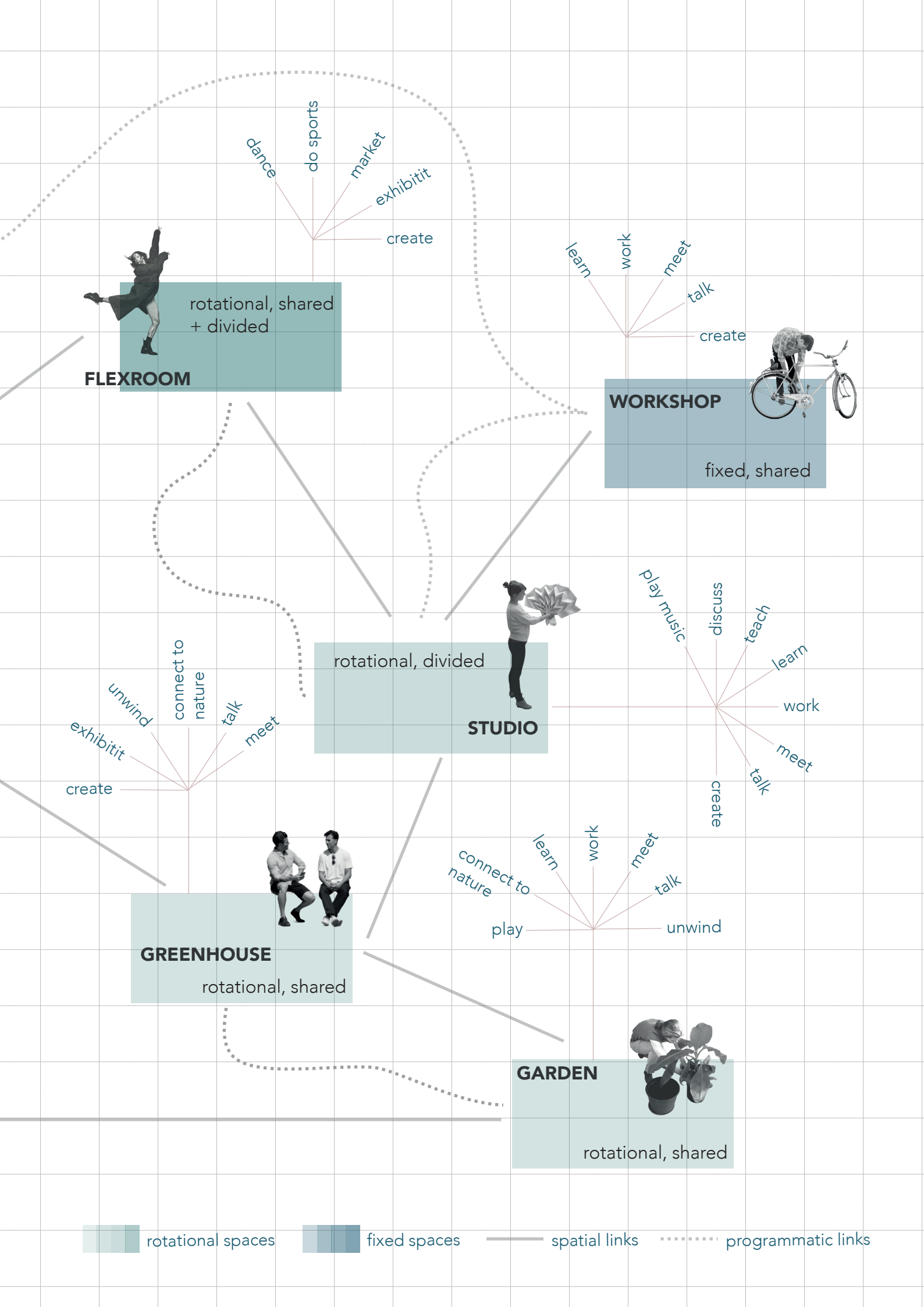

**FLEXROOM**  
rotational, shared + divided

activities: dance, do sports, market, exhibitit, create

**WORKSHOP**  
fixed, shared

activities: learn, work, meet, talk, create

**STUDIO**  
rotational, divided

activities: play music, discuss, teach, learn, work, meet, talk, create

**GREENHOUSE**  
rotational, shared

activities: unwind, connect to nature, talk, meet, exhibitit, create

**GARDEN**  
rotational, shared

activities: learn, work, meet, talk, play, connect to nature, unwind

rotational spaces    fixed spaces    spatial links    programmatic links

## Spatial organization

# Adapting the Building Frame and Inserting the Functions

In response to the design principles and the contextual analysis the building frame is adapted to house the proposed functions in correspondence with the set spatial categories. Most parts of the building are retained, with one part being removed to create a new outside area protected from the main circulation paths around the facility. A new main circulation

area connects the facility to the existing paths. New openings cater to the design principle of permeability, allowing for visual connections both from within the facility to the outside and vice versa. The existing outdoor program is expanded through additional programming.

### retaining most parts of the building

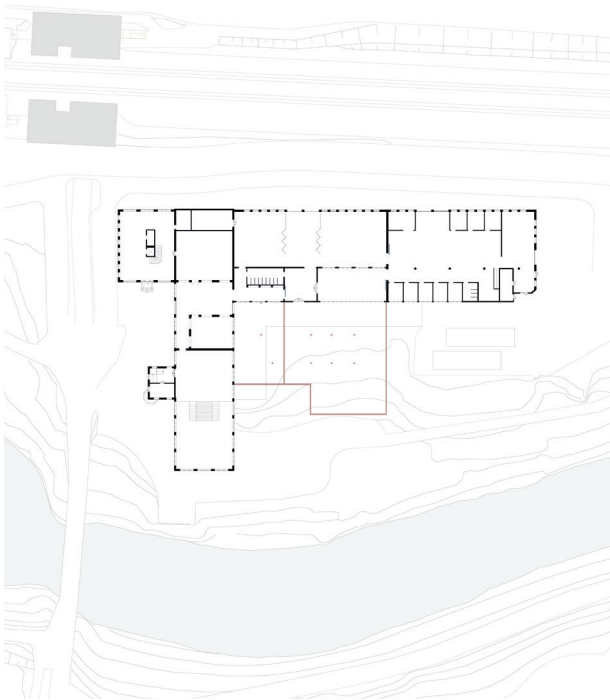

### connecting new circulation areas to existing paths

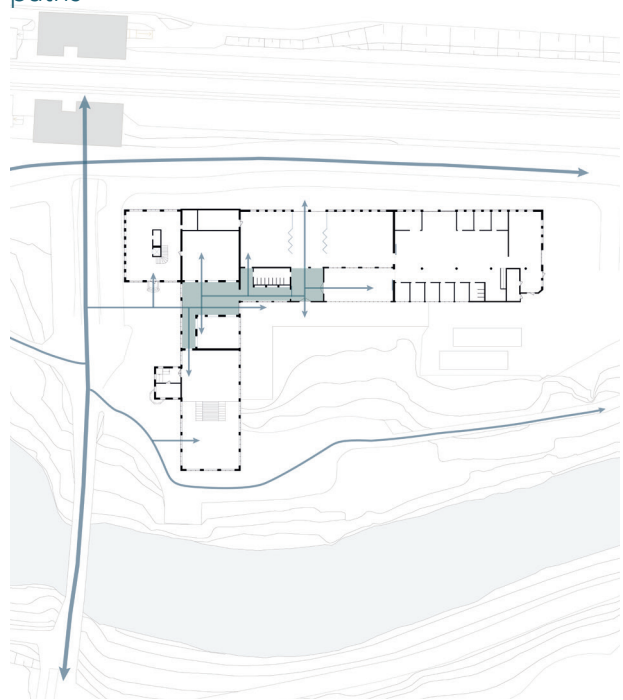

### new visual connections to the outside

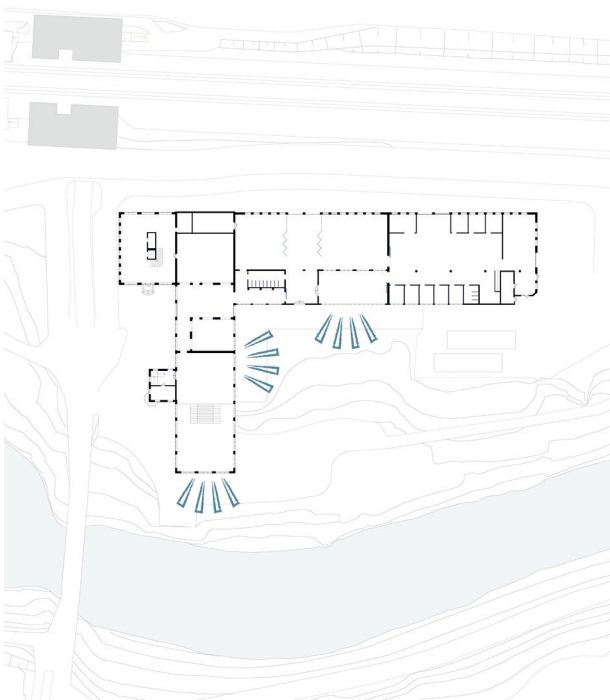

### expanding existing outdoor programs

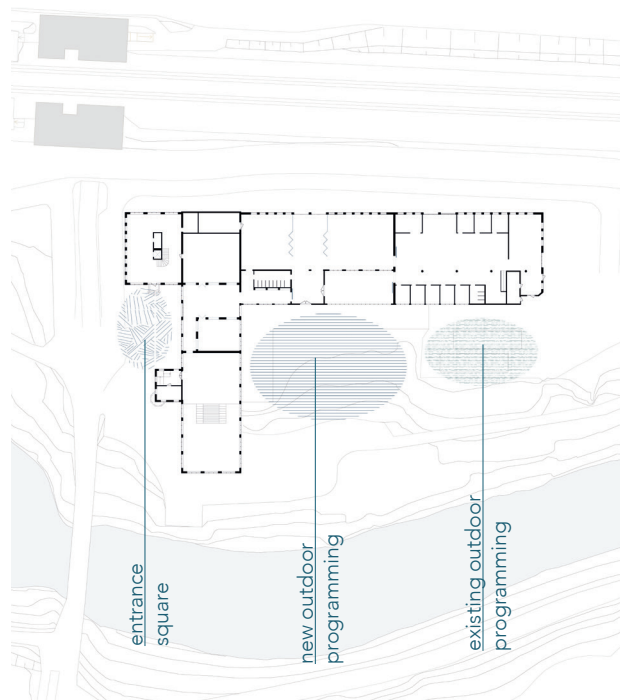

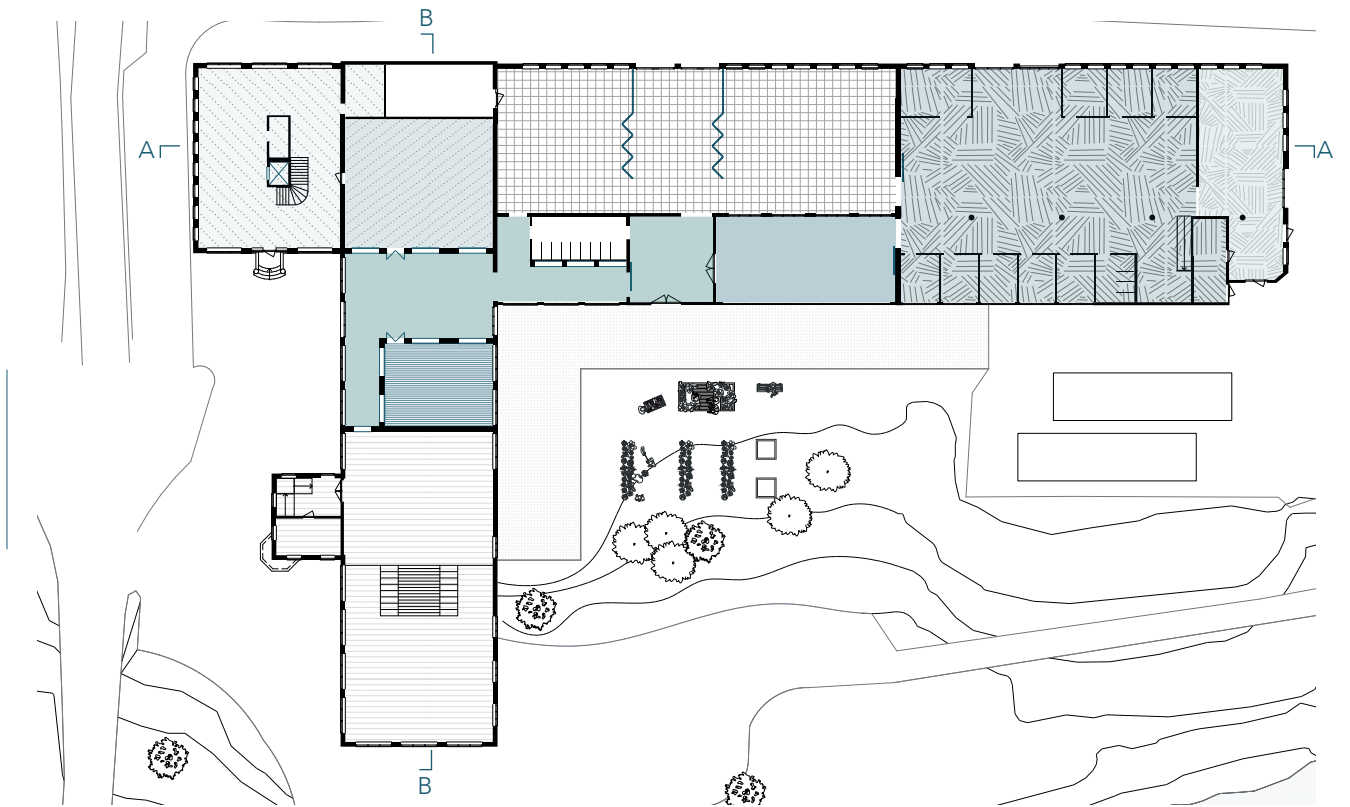

A - A

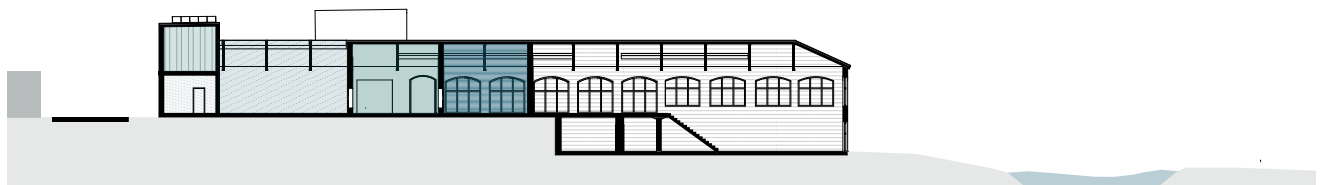

B - B

community hall	greenhouse
cafe	studios
community kitchen	workshop
co-working	reading and playroom
flexroom	main circulation

## TAKEAWAYS

To equip a Third Place with a sequential arrangement of rotational and fixed rooms, shared and divided spaces, contributes to the place being accessible to the broader community. Linking back to the before set principles of the Third Place in a rural context, this means to enable a **DIVERSE, DYNAMIC and ENGAGING** place.

Through the fixed functions, incentives are created to visit the place, while rotational spaces, that can vary in their use, enable the

users to take ownership of the place, adapt it according to their needs. This further contributes to the place being a **PLACE FOR DISCOURSE**, engaging the users in talks about how to use and adapt the space.

The sequential arrangement promotes an engaging environment, where the whole facility can be used for different activities simultaneously, and further, by passing by the different areas, an interest can be created to engage in ongoing activities.

# Building Elements to Enable a Third Place and Interactions

As a response to the Third Place and design principles, building elements were identified, that can enable a third place in the specific context of the existing building envelop of Kniven. These elements consist of both immobile and flexible elements and have different impacts on both the building and the way people interact with and within it.

## immobile elements

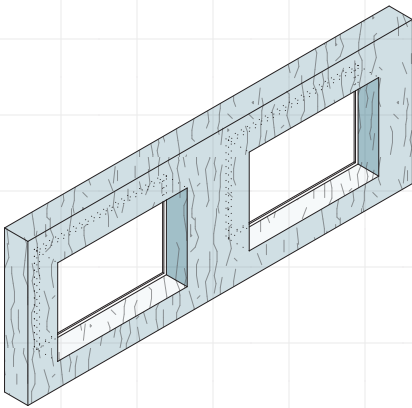

### WHAT and WHERE?

new walls with seating and widows to separate existing spaces

located along circulation areas

### WHAT does it ENABLE?

Circulation areas become areas for rest and spontaneous encounters. The inserted windows allow for visual connections between different activities and functions and promote interest in engaging in activities.

### WHAT and WHERE?

new windows and doors

along the façades facing the new courtyard

### WHAT does it ENABLE?

They allow for a new zoning and spatial organization of the building, opening up new possibilities for encounter and interaction between different activities.

New views inside the building are creating, enabling "people watching" as part of public space activity and creating incentives to stop by and engage in the place.

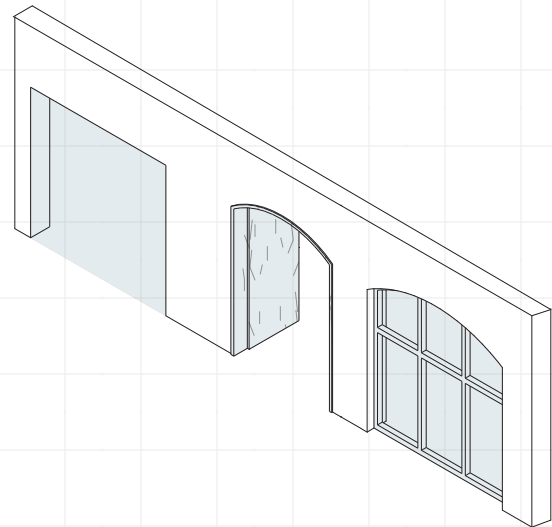

### WHAT and WHERE?

staircase as a dialogue structure

in community hall

### WHAT does it ENABLE?

As a seating and circulation element, it allows audiences to come together in the case of (socio-cultural) events happening in the community hall and further connects the existing built structure to the different terrain levels on the outside, creating new connections to the near surroundings.

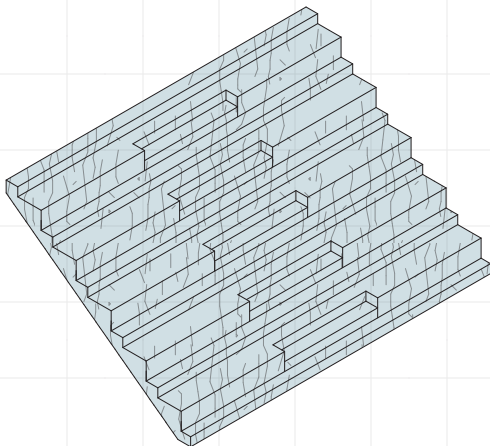

## flexible elements

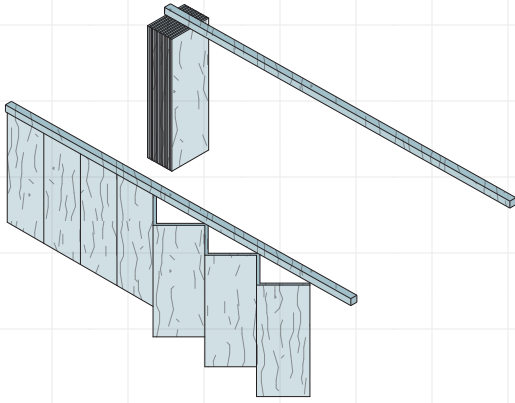

### WHAT and WHERE?

foldable walls

in flexroom

### WHAT does it ENABLE?

Walls can be opened or closed according to the needs of the users, allowing for different alternations of shared and divided spaces, further allowing for different activities to happen simultaneously.

The division of the space can be short-term or permanently, enabling adaptations to potential future needs.

### WHAT and WHERE?

modular furniture elements

can be used within the whole facility (both indoors and outdoors)

### WHAT does it ENABLE?

The flexibility of modular furniture elements allows users to adapt the space to their needs on a small scale. Sedentary activities become enabled, the furniture can be arranged in various ways to enable variations of activities and allow for different group sizes to come together.

Moveable elements for storing the furniture can be used as dividers and displays and allow for different configurations of the space.

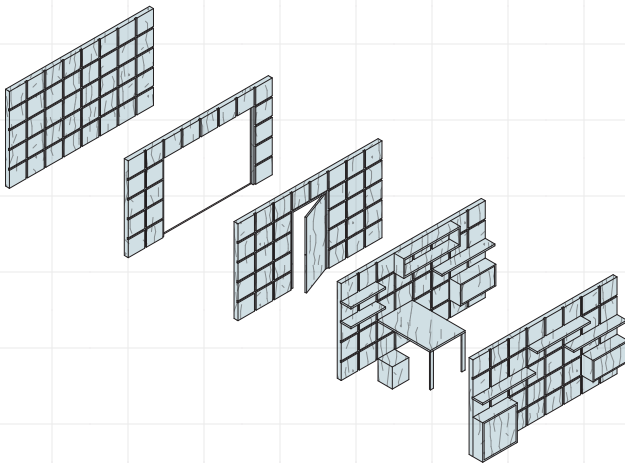
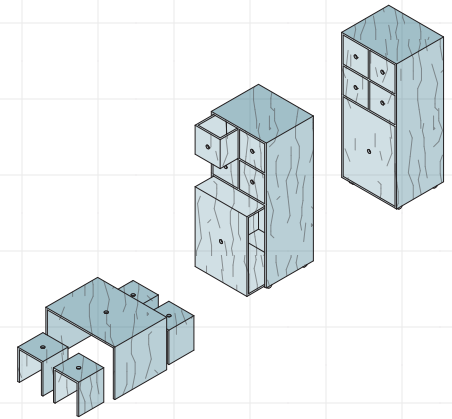

### WHAT and WHERE?

modular wall elements

in studio (creative and association space)

### WHAT does it ENABLE?

Modular wall elements allow for individuals to shape certain rooms to their needs and feel a sense of ownership when using the space

The modularity allows for different activities and promotes adaptability of the space according to the needs of the users

The basic wall elements are inserted permanently, further elements and additional features can be added if needed.

## TAKEAWAYS

The different building elements are based on the third place principle of the place being **GROUNDING IN THE EXISTING**, by proposing to insert new structures into an existing building frame.

Further these elements enable different atmospheres and activities and render the

place **DIVERSE** in its use, further allowing the space to be divided in different segments, to enable activities to happen simultaneously.

Considering elements in the design, that are flexible, like furniture and flexible wall elements, further renders the place **DYNAMIC** and allows for users to adapt their surroundings, giving them opportunities to take ownership of the place.



## Creating a Narrative Through Collages and Sketches

Throughout the thesis' process collages and sketches were used as a tool for research by design. They investigate and illustrate examples of use within the facility.

This entails to investigate varying activities, which could take place, but also how the place and the inserted building elements enable these activities. These explorations lead to a more thorough understanding about how a third place can contribute to community building and promote exchange and engagement across user groups.

The **first iteration** and sketches were hereby more abstracted, setting the ground for the further process. Through this method the design principles were defined and later during the process refined.

In the **second iteration**, the collages were adapted to the specific arrangement of elements in the proposed Third Place, testing out the building elements use and function and their impact on encounters within the place. Different scenarios of use and interaction were illustrated.

### First iteration and sketches



Collage 1:

- creating spaces that enable different activities in the same place; after each other > increasing sense of ownership and peoples ability to adapt the surroundings to their needs
- mixed and flexible use





Collage 2

- flexibility further means that the interiors need to be able to be rearranged, to create new spatial arrangements
- allowing for things to happen simultaneously
- creating visual connections; stimuli and interest to participate in other activities
- increasing chances for spontaneous encounters and interactions



Collage 3:

- seeing the outdoor space as an extension of the facility
- programming the outdoors with different activities to create incentives for people to engage with each other and the place
- providing weather protected (seating) areas to allow for meetings to happen



sketch 1:

- exhibition happening inside the flexroom
- potential collaboration between co-working and craftsmanship association
- informal encounters, exchange and discourse are enabled

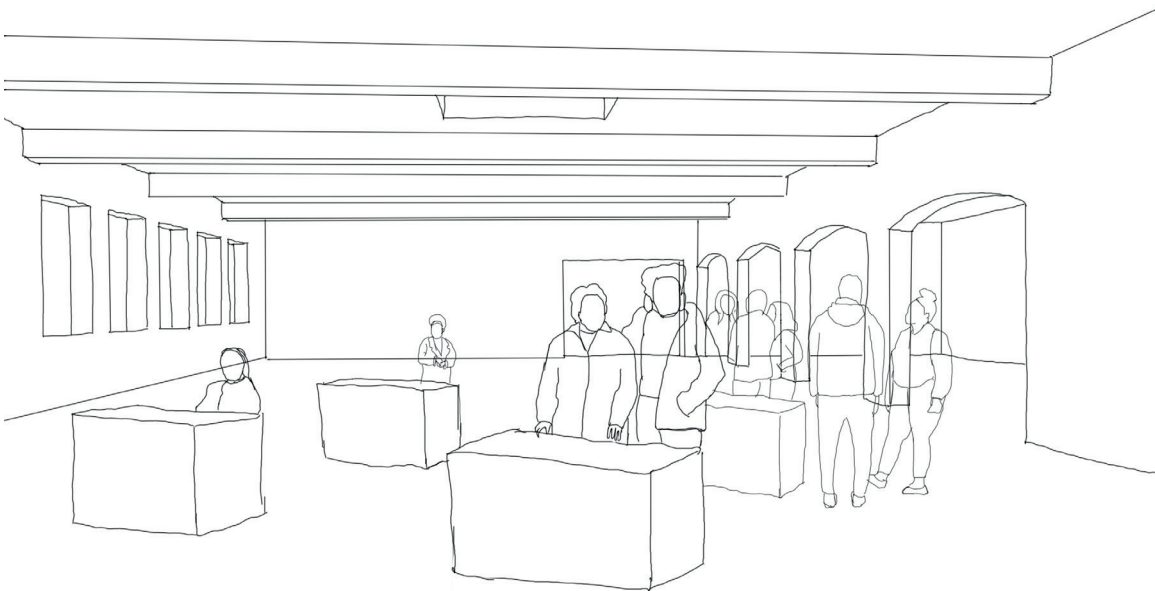

sketch 3:

- market inside the flexroom, expansion towards the outside
- visual linkage between different rooms
- community event, enabling economic and leisure based activities



## Second iteration



Hallways / Main circulation

- newly inserted windows and doors allow for a more diverse zoning of the place, and create visual connections throughout the buildings, thus creating incentives to stop by and engage in the place; newly inserted walls with seating and windows render circulation areas into places for spontaneous encounters and rest and further promote visual connections between different ongoing activities

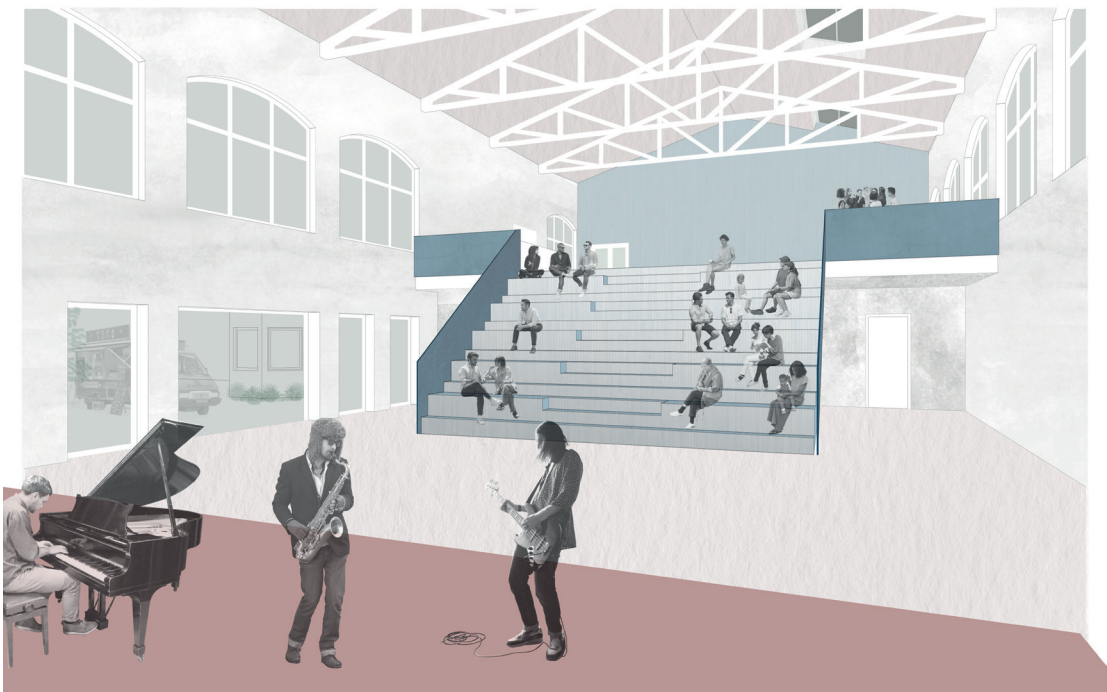

Community hall:

- a newly added staircase as a dialogue structure, allows audiences to come together in the case of socio-cultural events happening in the community hall and creating opportunities for discourse and exchange around the activities happening

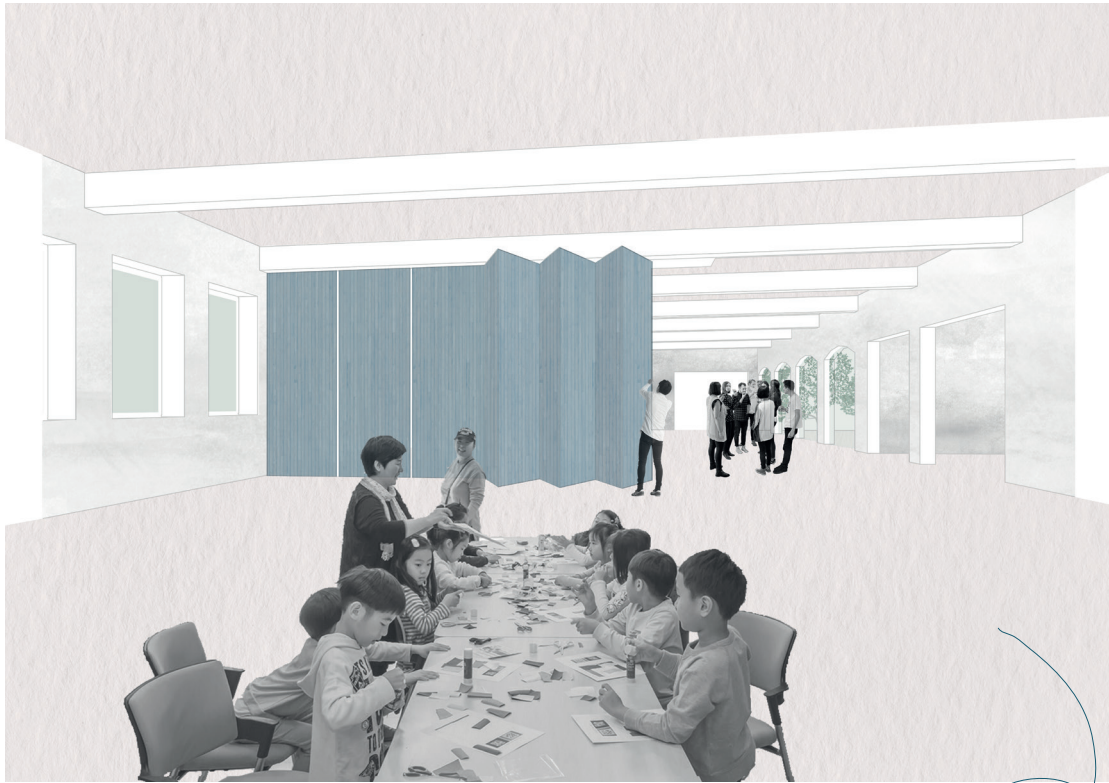

Flexroom:

- foldable walls in the flexroom allow users to change its layout from a shared to divided space and thus enable different activities to happen simultaneously

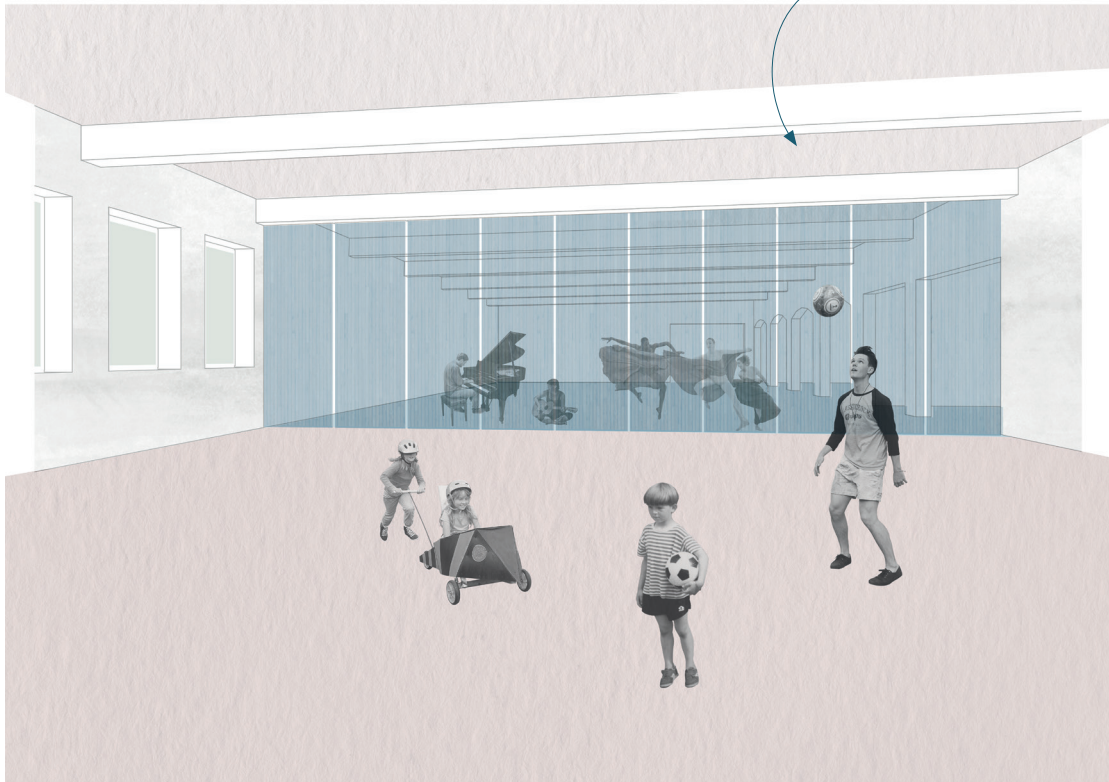



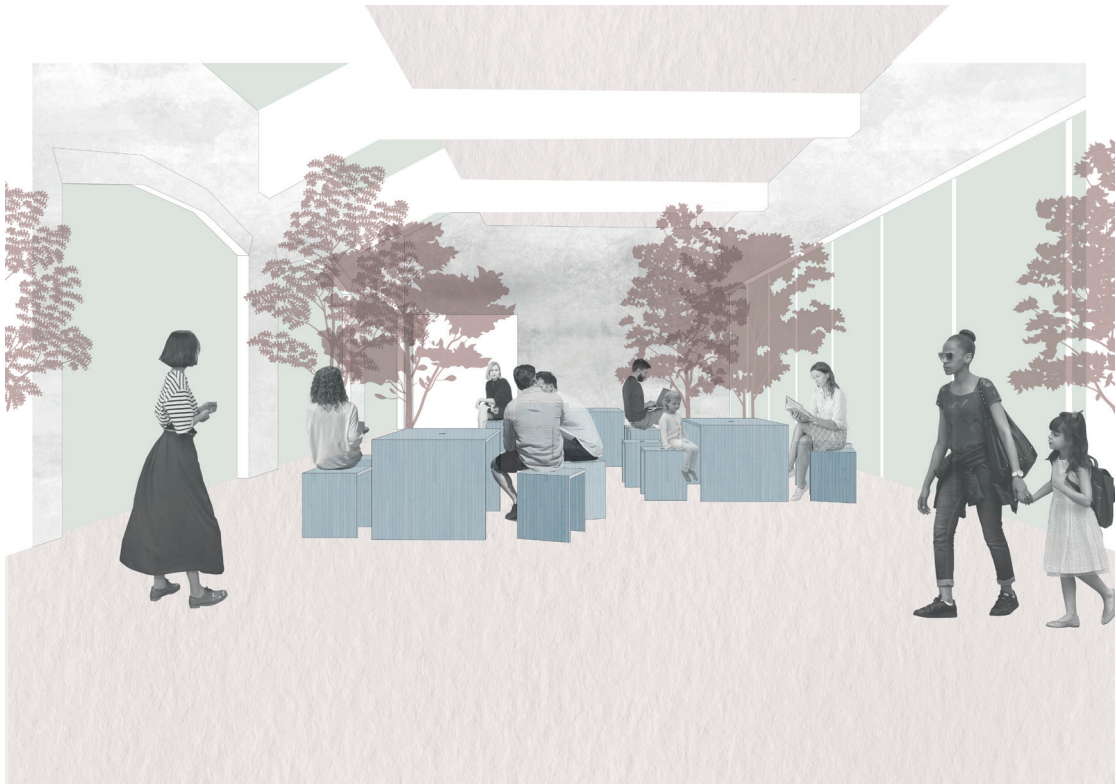

Greenhouse:

- modular furniture can be used throughout the whole building and allows users to gather in different groups, and spontaneously adapt the space to sedentary activities that they want to engage in

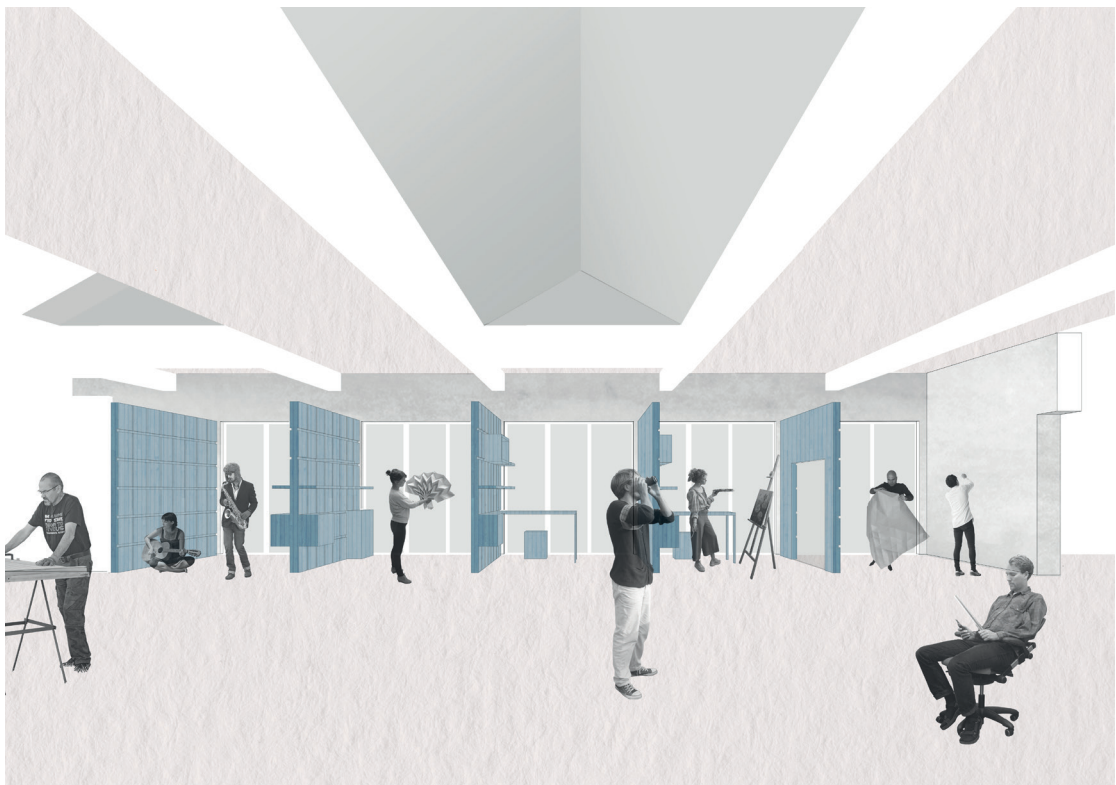

Studios:

- modular wall elements allow for individuals to shape certain rooms to their needs and feel a sense of ownership and place attachment when engaging in the place. the modularity allows for different activities to happen in parallel, potentially engaging users in discourse an exchange

## Collage iterations TAKEAWAYS

The collages illustrate different ways in which encounters could happen within the proposed Third Place. These encounters can vary from being both direct and indirect as well as intentional and incidental.

To strengthen connections within the facility visual connections both between the different functions and to the outside are an important factor, since they can contribute to encounters and create incentives for community engagement.

Users can decide of the level of engagement that they want to participate in, whether it be in smaller or bigger groups. Due to the arrangement of the programs in relation to each other exchange can be generated, meetings can happen across different groups, which can have positive impacts on community building.

In addition, the different rooms and elements allow for them to adjust the spaces according to their needs. Further a variety of activities can happen simultaneously. This could for example mean, that children and teenagers use one room for sports activities, while a concert happens in the community hall and members of the craftsmanship association create and discuss in the studios.

# Comprehensive synthetic axonometric overview

To conclude and synthesize the design explorations, the previous explorations are transferred into a comprehensive synthetic axonometric overview. This overview illustrates how the elements come together in the existing building of Kniven, in relation to its outdoor environment.

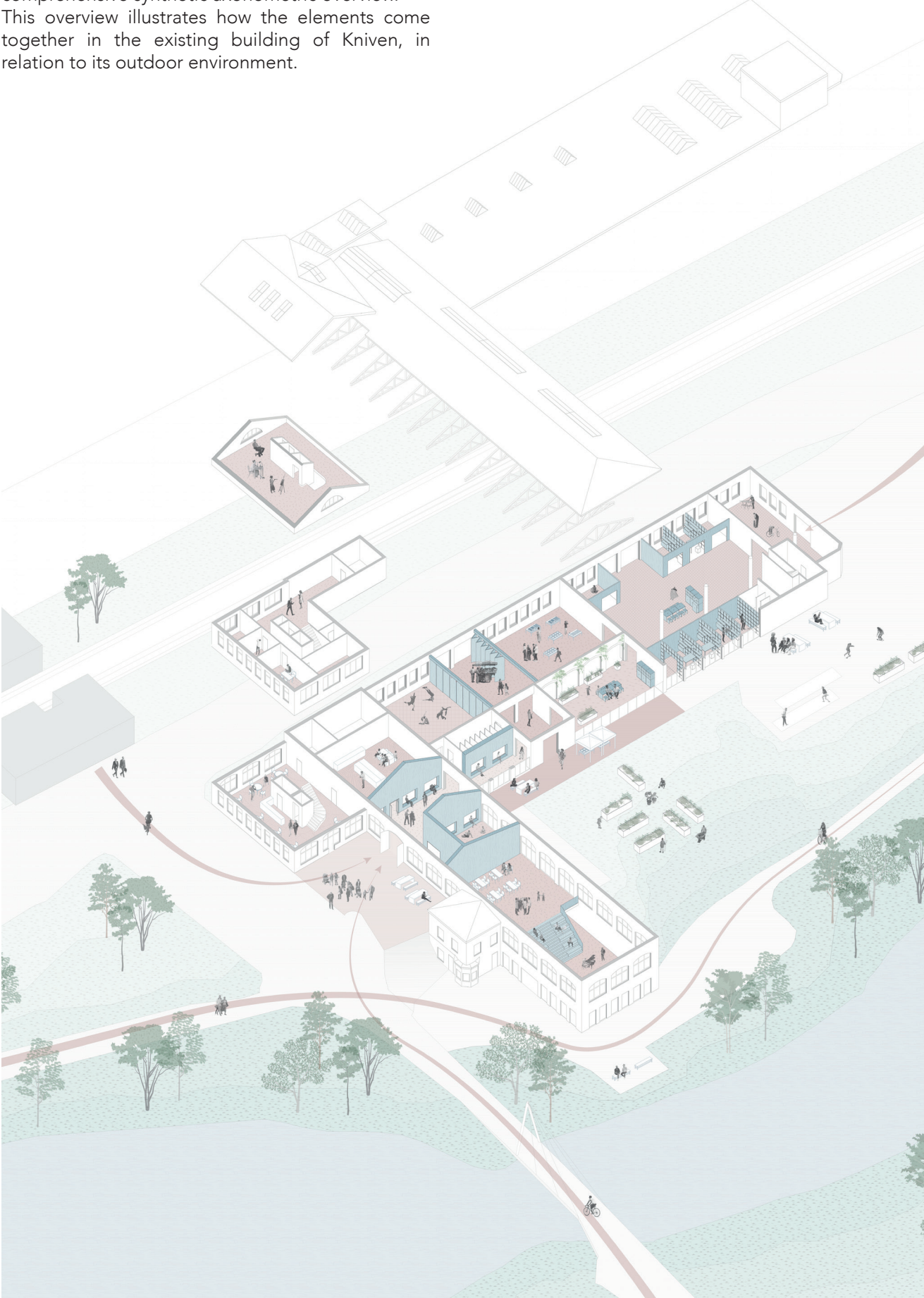



Comprehensive synthetic axonometric overview  
Location and program

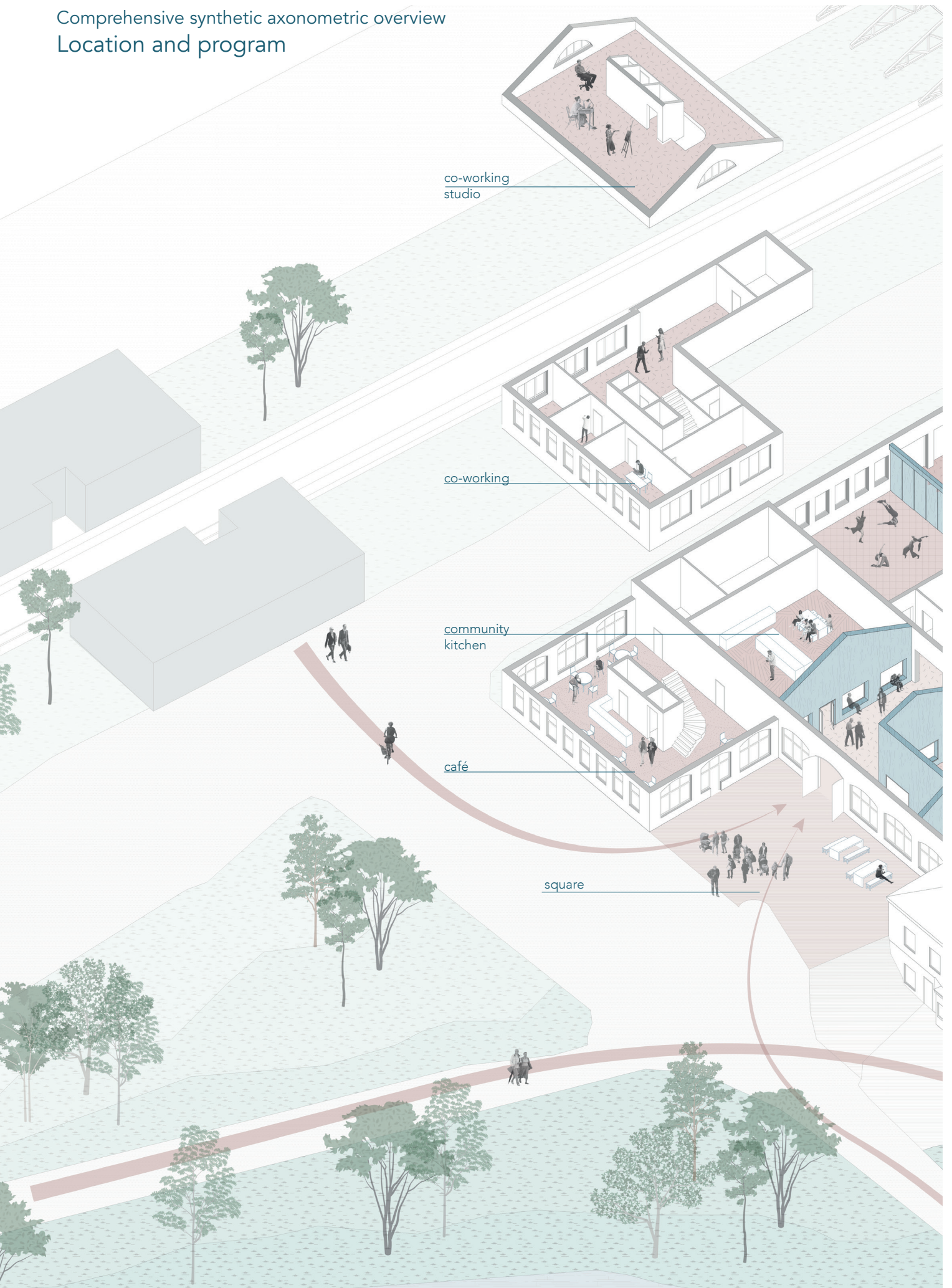





flexroom

workshop

studios

active area

greenhouse

community garden

reading + play room

community hall



## Comprehensive synthetic axonometric overview Arriving in the Third Place



The main entrance and square are located at the main route passing between the infrastructural hubs framing the site. Fixed functions such as the Cafe and the Co-working spaces are located in this area, to create incentives to stop by and engage in the place on everyday routes. Commuters can pick up a coffee on the way to work, or decide to work within the co-working areas. Different users can gather in the cafe to meet, engage in talks or take a rest.

Upon entering into the facility, users have an overview over the adjacent rooms. The circulation areas become places for spontaneous encounter.



## Comprehensive synthetic axonometric overview Engaging in Community Activities



The community hall is located close to the river, acting as a further attractor to the facility. Here socio-cultural and community events can happen. In the community kitchen, the users can gather to use the produce from the community gardening, kids and teenagers can gather after school, the users of the studio can prepare their lunches. Encounters across different user groups are enabled around the central activity of eating and talking. The reading and playroom provides users with a quite place to detach from their everyday life, here they can engage in game nights or in events organized in collaboration with the local library.



## Comprehensive synthetic axonometric overview Engaging Outdoors



The newly established courtyard allows for the community to gather outside and engage in activities together. Due to the adjustments on the building frame, this area is protected from the main circulation routes around the building, creating a safe environment for encounter. Views from and to the inside of the building engage the users in spontaneous encounter.

Building on the existing outdoor programming on site, a community garden provides them with the opportunity to create and learn. Markets or events can be held on the outdoor terrace and expand to the inside of the building.



## Comprehensive synthetic axonometric overview Adapting Spaces



Both the studios and the flexroom enable users to adapt spaces to their needs. The flex room can be separated to allow for different activities to happen simultaneously, like markets or dance classes. These activities can further be extended to the outdoors and greenhouse. In the studios, the existing craftsmanship association can hold workshops, and individuals can shape the smaller studio units according to their needs. Through these implementations, the building frame becomes a structure for opportunities, where different needs with regard to the requirements for third places can be met.





## Reflection and Discussion

To conclude the thesis, a reflection and discussion in dialogue with the theory and findings from the process is carried out. The general process and the answer to the research question are debated.

The aim of this thesis was to investigate and discuss the notion of Third Places and their impact on community interaction in urban settings.

Using different methods, the topic was approached taking into account theoretical, contextual, user and building dimensions. These provide a basis for the final reflection. In the following, reflections are made in relation to answering the thesis question, the influence of the urban context on Third Places, and the process of the work. A revised network of Third Places in the immediate surroundings of Kniven is used as a discussion tool.

### The Process and Method.

The impetus for the work was the interest in using an existing building, which is to be put to a new use in the future, as a framework for such a third place, and in doing so to ask the question under which aspects the future use can be guided by the needs of the users. In the course of the work, the question of the user perspective and the contextual conditions of the urban environment came further to the fore. In order to take these dimensions into account in the work, methods such as third place mapping, transects and collages were used. This led to a more abstracted approach to the topic. The work with collages in particular made it possible to approach the topic through a narrative of the emergence of places through their use. In several instances, these were iterated and thus adapted to further design considerations. The final translation of the design explorations made it possible to transfer the findings to the existing building.

The methods chosen made it possible to approach the topic from different points of view. Especially when taking into account the user perspective, these could possibly have

been expanded to include further aspects. If the project were to be continued, methods such as interviews, surveys or prototypes for elements to be tested on site would be useful to further discuss the design explorations in relation to actual user opinions. However, this would have exceeded the scope of the present work.

### Reciprocal relationships between Design and Theoretical Approaches to the Subject Matter

The topic began with a theoretical examination of the theme of third places. Here, the theory was placed in the current discourse.

This discourse showed that the principles of third places need to be adapted. In particular, the criticism was raised that third places are generally understood to be associated with the consumption of products and services. However, as these places are supposed to contribute to the promotion of the community, this peculiarity creates barriers that need to be overcome.

The reference to the specific needs of the users therefore plays a central role. In order to create truly accessible places, as defined by Oldenburg, they have to fulfil certain specific programmatic aspects. Through the iterative design process, it has been shown that this can be achieved through a mix of uses, both fixed and flexible. The combination of functions such as a café (a classic third place), spaces for creative expression in interaction with existing actors from the surrounding area, as well as unprogrammed spaces that can be adapted by the users themselves, have manifested itself in the design process as a possible approach for this.

This mix also allows a third place to respond to current trends in how users interact with their environment outside of work and home, combining these two reference spaces.

Providing the user with co-working areas allows them to socialize and connect to others during working hours without the necessity to refer to other places for doing so.

Over the course of the work, it also became evident that the principles of third places as dynamic and engaging play a central role in ensuring that the positive effects of these places can be realised. The flexible spatial elements developed for this purpose enable the users to adapt their built environment to their specific needs. Through the implementation of these elements, the spaces themselves become rotational spaces that can be used in a variety of ways. This makes the third place a place of possibilities. The adaptability of these places contributes to identification and a sense of place attachment, dimensions identified as essential in the theoretical considerations.

### Actors, Stakeholders and Management.

The analysis and consideration of actors who can operate and manage Kniven as a Third Place in Partille was not a central part of this work. However, it is important to also discuss this aspect in regard to the findings that have been elaborated on over the course of the thesis development.

The contextual analysis and theoretical framework identified the involvement of ongoing activators as an important component for the implementation of a new Third Place, as they can ground such a place in the existing environment and create initial incentives for its use.

In the specific context of Partille, the existing craftsmanship association and garden association were considered. They could also play a central role in the management of the place and co-manage access to the building, at least in part.

Another important actor for the implementation, management and financing of the place could be the municipality. The municipality is already closely involved in the use of Kniven in its interim use and manages its use, rents and administers the individual premises. Involving the municipality would also have the advantage that a largely objective actor would act as a mediator between different interests and users.

The municipality could, above all, support the users in managing the place themselves in the long term. In the best case, an association would be formed around the third place under their guidance, which could take over certain responsibilities. However, from the point of view of accessibility, it is important that such an association does not create new thresholds for use and users. This aspect will be discussed a lot in the course on third places, as associations are often associated with a certain degree of exclusivity. Membership in such an association should therefore not be binding for the use of the place.

### Scale and Accessibility.

Third Places in their nature as social surroundings should provide the individual with the possibility to detach from everyday life individually. This has to be considered in the design of such a place.

As the facility of Kniven is an already existing building, that is to be adjusted to house a Third Place and was prior used as a factory, this question of scale posed additional challenges.

The proposed design is largely based on the assumption that this place will be used primarily as a meeting place where exchange with others will play a central role. In this respect, the premises are divided into larger units that are mainly accessed from a central circulation

area to promote spontaneous encounter and exchange.

It could be debated whether a division of the building into smaller units and spaces would be more suitable to accommodate for the individuals needs and to provide users with more diverse access points. This would allow for them to (temporarily) occupy a space by themselves and shape it to their needs. On the other hand this would pose additional challenges in terms of regulating who has access to the spaces and who manages them. Further, this could lead to people meeting primarily in their usual groups, potentially decreasing the chances for encounter and engagement across these groups.

More access points into the facility can further have an impact on how people perceive the space. It might lead to the individual feeling as if the individual spaces are not accessible to them and are being rather exclusive.

### Reference to the Rurban and Impact of Design on the network of third places

The dimension of the rurban took a central role in the context of the work. Through the methods of transects, the examination of official documents and the analysis of the closer context with regard to existing third places, strengths and weaknesses of this setting were identified. The little variety of diverse meeting spaces in the proximate area of central Partille and the fact that most places available are linked to the necessity of consumption, creates a basis and justification for the creation of a third place on this site.

Through its close proximity to both a bigger town and rural areas, the third place can further act as place for exchange not only within the neighbouring community, but also across these zones, by providing spaces that invite users through their potential use as socio-cultural

centres.

As Partille is as many rurban areas, affected by continuous growth and densification, newcomers to the area can find a starting point for connection to the community in the third place.

To tie back to the observations on the rurbanity of the context to implement a third place within Partille could not only facilitate exchange within the neighbouring community and provide them with a diverse meeting place, that enables encounters in their proximate environment, without the necessity to refer back to either the urban or rural environments.

It also holds the potential to invite users from both the urban and rural zone surrounding Partille, creating a stronger connection, prompting exchange and encounter across these zones and rendering Partille as a destination rather than a point of passing through.

As opposed to the urban environment, where there is a great variety of spaces that are considered as Third Places, a rurban Third Place needs to be able to cater to and enable a bigger variety of uses and programs, to be able to address the community needs and enable different forms of encounter.

To implement the third place in Partille, could further have effects on the already existing third places. A potential exchange between the different facilities and places could be generated, the programs could complement each other.

The suggested programming allows for existing activators, as well as new actors to take part and create a network.

The gardening and craftsmanship association could activate the place and offer programs such as workshops and events to open up to and invite the broader community. These could be held also in collaboration with the existing

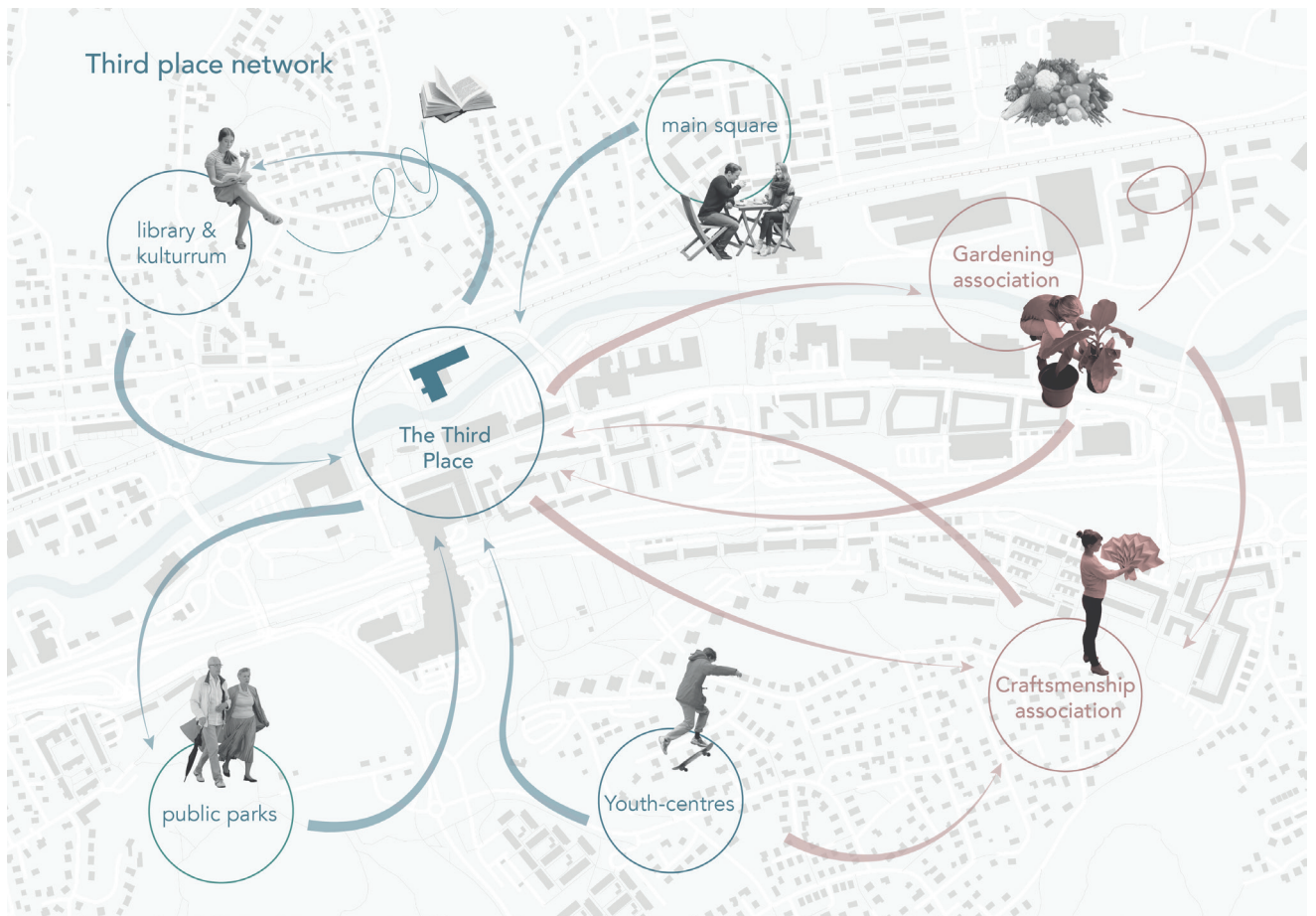

youth centre or other actors from the area. The implementation of the community hall as well as the reading and play room enables collaborations with the local library and kulturrum, allowing for them to expand their program onto the newly implemented Third Place.

The close proximity to the local square and the existing parks could generate new flows of movement through Partille.

### Summary

In conclusion, it can be said that in the context studied, such a place can contribute to community building and encounters by combining several dimensions in its use.

An offer of functions must be created that creates initial incentives to visit this place through its fixed forms of use (such as the café in this case or the integration of existing actors). Furthermore, spaces must be offered that can be adapted by different user groups to their needs. This is where the aforementioned sequences of rotational and fixed, shared and divided spaces come into play.

In an existing building, these spaces and functions must be arranged and opened up to

the immediate surroundings in such a way that they create an incentive and interest to interact with the space as one passes by. Furthermore, the flexibility of the spatial structure contributes greatly to the users' ability to adapt the space to their needs and to enable different types of gatherings.

And lastly, through providing unprogrammed spaces and leaving the opportunity for users to adapt these spaces in the future, it is ensured, that these spaces can adapt to changing needs.



# Appendix



# Student Background

## EDUCATION

**master of science, architecture**  
Chalmers University of Technology

08|2021 - current

llstudios  
local context, reality studio, residential healthcare - dementia village

**bachelor of science, architecture**  
Technical University Berlin

10|2016 - 02|2020

llstudios  
library, artist apartments, stonemasonry and studios, student housing, bikeport  
BA thesis - strategies for urban densification

## WORK EXPERIENCE

ll Goller Architekten

freelance draftswomen 08|2018 - 08|2020  
draftswomen, Bsc. Architecture 08|2020 - 07|2021

detailed planning for:  
renovation projects, building extensions & individual buildings  
construction management and administration

---

**Hiltja Harmuth**





[hiltja.harmuth@student.chalmers.se](mailto:hiltja.harmuth@student.chalmers.se)  
+4917653821151

## References

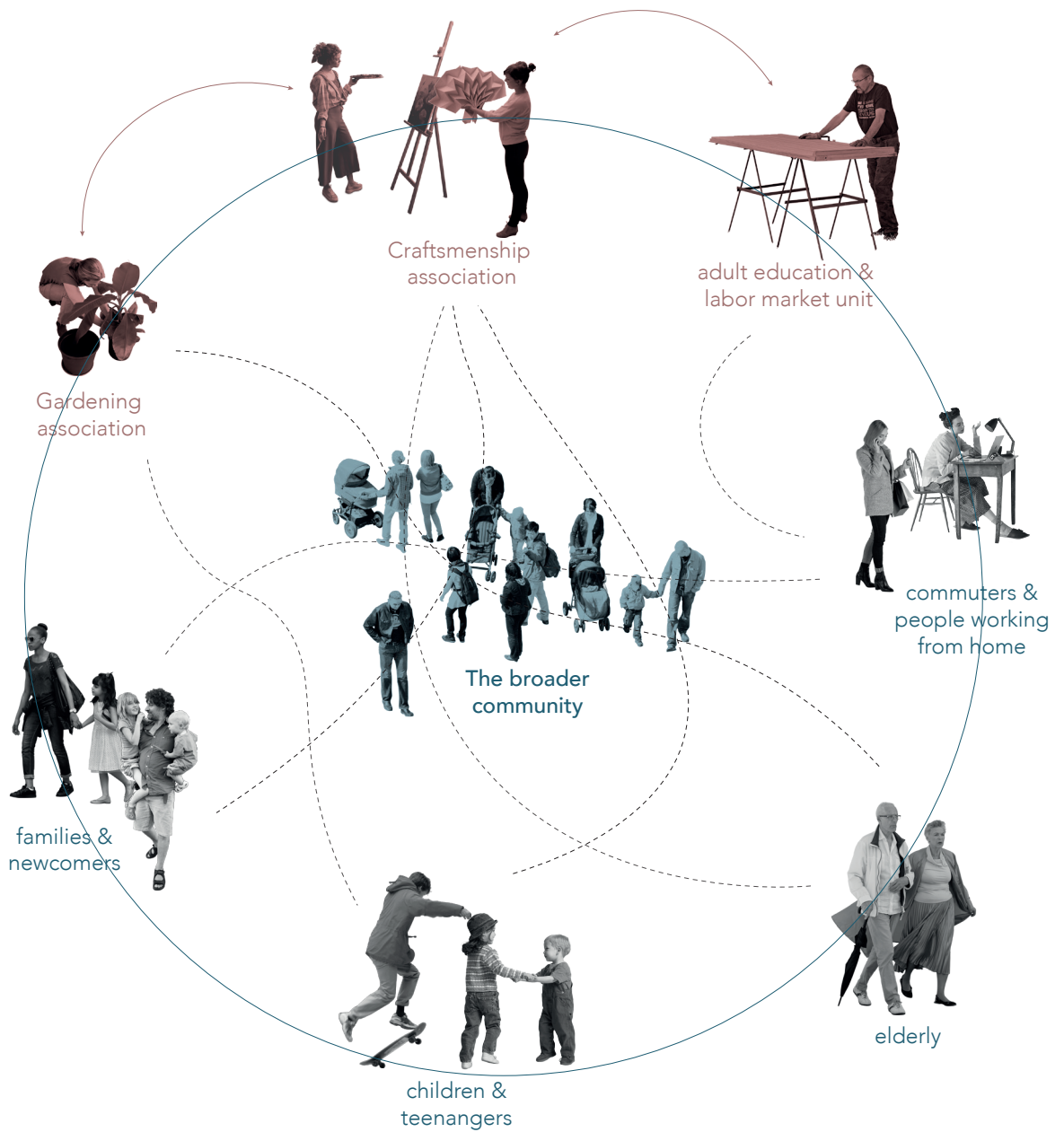
- Befolkningsprognos 2021-2030. (n.d.). Partille Kommun. <https://www.partille.se/kommun--politik/kommunfakta/befolkning/>
- Drews, Katja (2021). Was verändern Dritte Orte? (n.d.). Retrieved September 7, 2022, from [https://www.soziokultur-change.de/diskurse/dritte\\_orte](https://www.soziokultur-change.de/diskurse/dritte_orte) (DREWS)
- Jeffres, L. W., Bracken, C. C., Jian, G., & Casey, M. (2009). The Impact of Third Places on Community Quality of Life. *Applied Research in Quality of Life*, 4(4), 333–345. <https://doi.org/10.1007/s11482-009-9084-8>
- Klassen, T. (n.d.). COMMUNITY HUB – heartbeat of the third place economic space. [www.linkedin.com](http://www.linkedin.com). <https://www.linkedin.com/pulse/community-hub-heartbeat-third-place-economic-space-terry-klassen/>
- Lee, N. (2022). Third place and psychological well-being: The psychological benefits of eating and drinking places for university students in Southern California, USA. *Cities*, 131, 104049. <https://doi.org/10.1016/j.cities.2022.104049>
- Löw, M. (2001). *Raumsoziologie*.
- Murray, R. M. (2014, December 9). The joy of a third space: How the concept of a community hub is evolving. *Medium*. <https://medium.com/@rachelmmurray/the-joy-of-a-third-space-how-the-concept-of-a-community-hub-is-evolving-3292b1961cda>
- Målbild Partille centrum 2035. (n.d.). Partille Kommun. <https://www.partille.se/bygga-bo--miljo/samhallsplanering/fler-planeringsforutsattningar/malbild-partille-centrum/>
- Oldenburg, Ray (1989). *The Great Good Place: Cafes, Coffee Shops, Community Centers, Beauty Parlors, General Stores, Bars, Hangouts, and How They Get You Through the Day*.
- Pilzer, Harald (2017). Öffentliche Bibliotheken und "Dritte Orte" - eine neue kulturpolitische Strategie ? in *ProLibris*, Issue 3, 2017
- Slater, A., & Koo, H. J. (2010). A new type of "Third Place"? *Journal of Place Management and Development*, 3(2), 99–112. <https://doi.org/10.1108/17538331011062658>
- Yuen, Felice & Johnson, Amanda J. (2017). Leisure Spaces, Community, and Third Places, *Leisure Sciences*, 39:3, 295-303, DOI: 10.1080/01490400.2016.1165638

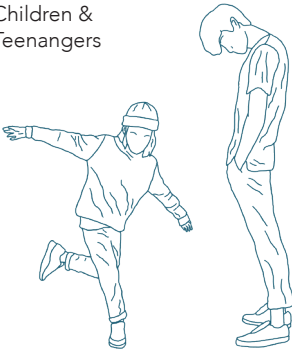
# User profiles established as a base for the development of collages



Personas	Why ?	Needs / Demands
<p>Children &amp; Teenagers</p> 	<ul style="list-style-type: none"> <li>• age 0-17 ca. 23% of Partille Population</li> <li>• municipal documents: missing spaces for leisure and meeting for this group</li> <li>• research: implying positive effects of TP for this group (vulnerable to social isolation)</li> <li>• interesting group with variety of personal / individual interests</li> </ul>	<p>spatial:</p> <ul style="list-style-type: none"> <li>• engaging indoor and outdoor spaces</li> <li>• „hangouts“ (for after school, preschool)</li> <li>• pot. spaces for creative expression</li> <li>• extracurricular learning-spaces</li> </ul> <p>„intangible“</p> <ul style="list-style-type: none"> <li>• spaces for networking within and beyond their „peer groups“</li> <li>• possibilities to detach from home</li> <li>• access to evening weekend activities</li> </ul>
<p>Commuters &amp; People working from home</p> 	<ul style="list-style-type: none"> <li>• location of Kniven on infrastructural hub &gt; people passing by regularly</li> <li>• significant group of Partille population</li> <li>• shift in understanding of 1., 2. 3. place &gt; shift towards melting of 1+2 place</li> </ul>	<p>spatial:</p> <ul style="list-style-type: none"> <li>• place to step in and meet people on their way to and from work</li> <li>• place to work from</li> <li>• place for encounter/engaging in community activities „after hours“ and on weekends</li> </ul> <p>„intangible“</p> <ul style="list-style-type: none"> <li>• possibilities for socialising throughout the week</li> <li>• possibilities to detach from work during the evening / weekends</li> </ul>
<p>Newcomers</p> 	<ul style="list-style-type: none"> <li>• municipal documents: increase in population over the next years &gt; relating to societal challenge</li> <li>• „vulnerable group“ - crucial for community building</li> <li>• diverse group of individuals; (young) families</li> </ul>	<p>spatial:</p> <ul style="list-style-type: none"> <li>• meeting space (community centre)</li> </ul> <p>„intangible“:</p> <ul style="list-style-type: none"> <li>• space for encounter</li> <li>• possibilities to engage in existing networks and community</li> <li>• access to events / activities</li> </ul>
<p>Partille h�nder member</p> 	<ul style="list-style-type: none"> <li>• ongoing activator ( „Place regular“)</li> <li>• focus/ interest in craftsmanship</li> <li>• program open to community (occasionally)</li> </ul>	<p>spatial:</p> <ul style="list-style-type: none"> <li>• (crafts) workshop</li> <li>• places for holding workshops, markets, showcasing their works</li> </ul> <p>„intangible“</p> <ul style="list-style-type: none"> <li>• networks &gt; exchange platforms</li> <li>• possibilities to teach/share their knowledge</li> </ul>