

ADAPTIVE ARCHITECTURE

HISTORICAL BUILDINGS ADAPTED TO SEA LEVEL RISE

Marika Klevell

Master Thesis 2024
Chalmers School of Architecture
Department of Architecture and Civil Engineering

Examiner: Mikael Ekegren
Supervisor: Catharina Dahl Palmér

Adaptive architecture
Historical buildings adapted to sea level rise

Master Thesis 2024
Chalmers School of Architecture
Department of Architecture and Civil Engineering
Master's Programme of Architecture and Urban Design

Author: Marika Klevell
Examiner: Mikael Ekegren
Supervisor: Catharina Dahl Palmér

Keywords: Klippan, sea level rise, retrofitting





Klippan

October, 2023

Abstract

Rising sea levels threaten many areas worldwide and in combination with extreme weather events such as storms and heavy rain, the challenge of keeping cities and areas above water is growing.

The investigation takes place in Klippan in Gothenburg harbor which is vulnerable to flooding caused by rising sea levels. The city has a strong connection to water as it is situated on the west coast and further inland along the river Göta älv.

Klippan played a significant role as a port location for Gothenburg harbor during the 17th century. To preserve the history and the characteristics of Klippan it has since then been declared as a cultural reserve. The reserve has a mix of buildings still standing from companies such as Ostindiska kompaniet and Carnegie's sockerbruk.

The region located in Klippan, which runs along the river, has an elevation that varies from 1 to 2 meters. As a result, the shoreline is prone to flooding. It is estimated that by the year 2100, large parts of the area are likely to be flooded during storms and high waters.

The investigation was centered on two historically valuable buildings in Klippan, which are at risk of flooding by 2100. With similar situations as a starting point, Sjömagasinet and Klippans Konstcafé were retrofitted with two different strategies depending on their conditions to adapt them to rising sea levels.

Depending on which strategy is applied, the program of the building may be affected. It is explored through the two buildings, resulting in a new program for Klippans Konstcafé while the program for Sjömagasinet is preserved. The thesis questions how the choice of retrofitting strategy affects an existing building's program.

There's a strong reason to implement retrofitting strategies from a preservational point of view in Klippan. The proposal showcases an example of how one can preserve the historical and architectural qualities of structures in a flood-prone area, while also ensuring that the buildings can function during high waters caused by rising sea levels and increased extreme weather conditions.

Keywords: Klippan, sea level rise, retrofitting

Contents

Introduction	9	Retrofitting	39
Purpose/ aim	10	Sjömagasinet x Amphibious	42
Thesis question	11	Klippans Konstcafé x Wet floodproofing Program	52
Research question	11		55
sub question	11		
The objective	11		
Background	12	Conclusion	77
Sea level rise	12	Discussion	77
Extreme weather	12	Reference list	78
Klippan	12	Figures	79
Methods and tools	13	Student background	80
Theory	14		
Delimitations	14		
Reading instructions	14		
Retrofitting strategies	15		
Amphibious House	16		
Cisternerne	18		
Le Relais Boréale Brewery	20		
Investigation	22		
Flooding simulations	26		
Context & Site analysis	29		
Flood mapping	29		
Konstcafé & Sjömagasinet	29		
Conditions	29		
Sjömagasinet	30		
Klippans Konstcafé	34		

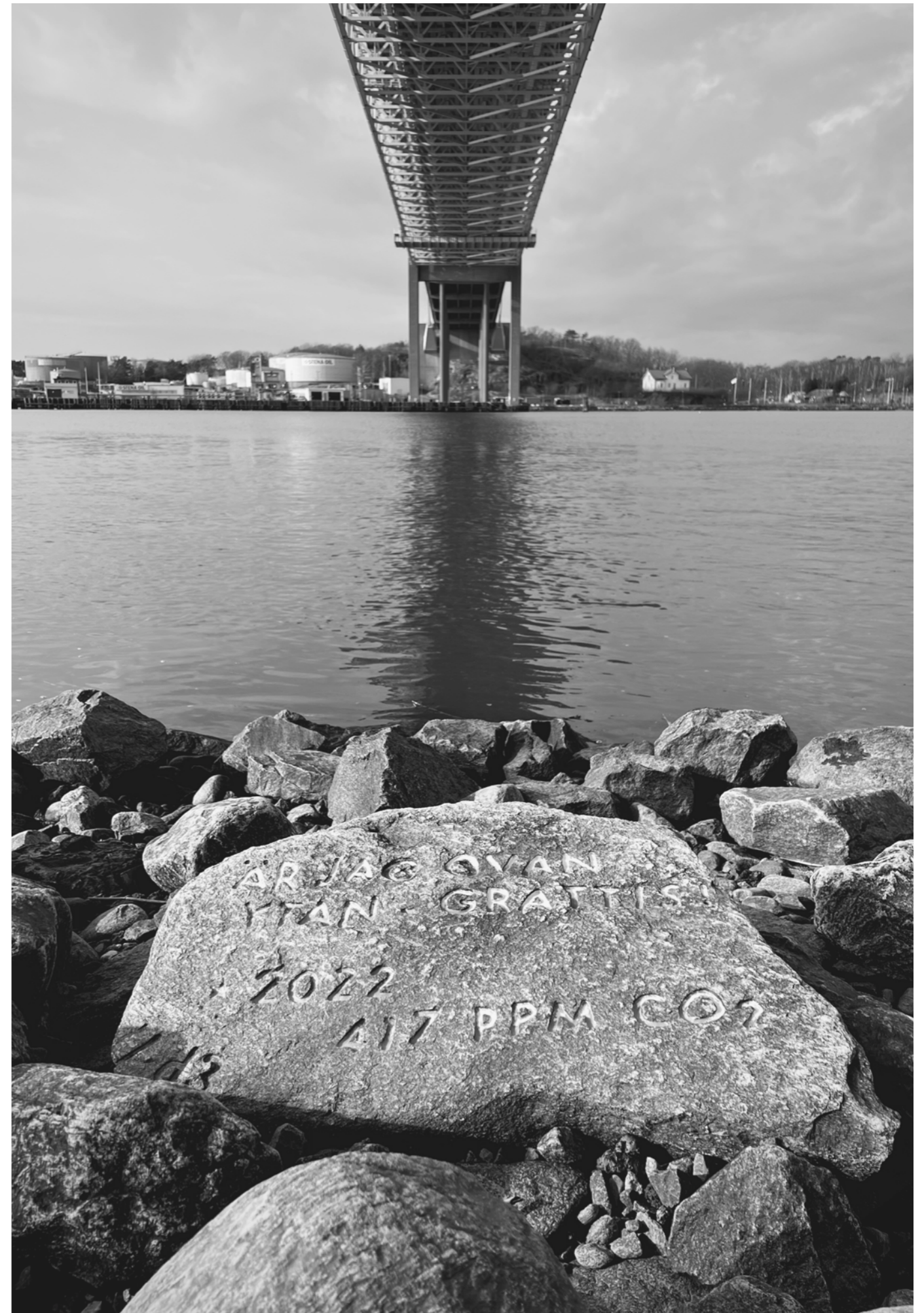

March, 2024

Klippan



Introduction

Purpose/ aim

Thesis Question

Background

Theory

Purpose/ aim



Klippan, October, 2023

The aim of this thesis is to investigate how to preserve and adapt two buildings in a flood-prone area by utilizing various retrofitting strategies.

This thesis also explores how buildings can function during high waters caused by rising sea levels and increased extreme weather conditions.

Through Klippans Konstcafé and Sjömagasinet the connection between program and retrofitting

strategy is explored. The thesis evaluates how the existing programs could function in combination with the chosen retrofitting strategy, or if a new program could be proposed.

Rising sea levels threaten many areas worldwide and in combination with extreme weather events such as storms and heavy rain, the challenge of keeping cities and areas above water is increasing.

Thesis question

Research question

How can a building with cultural and historical value be adapted to rising sea levels?

Sub questions

Which strategies for retrofitting buildings are relevant when working with historical buildings?

How does the choice of retrofitting strategy affect an existing building's program?

The objective

A transformation project of two buildings in Klippan, Gothenburg. Resulting in preserving the program of Sjömagasinet while adding a brewery and an exhibition space to Klippans Konstcafé. The project is expressed in drawings, visualizations, physical models and a booklet.

Background

Sea level rise

Global mean sea level (GMSL) is rising and is already a threat to big parts of the world.

The Intergovernmental Panel on Climate Change (IPCC) writes in their report that the GMSL will likely rise between 0.24- 0.32 m by 2050 and 0.43 m- 1.10 m by 2100.

IPCC also shows a study that points to an increase between 2.3-5.4 m by the year 2300 (IPCC, 2022).

Extreme weather

In the Gothenburg area, the tides are sparingly changing with approximately 25 cm . In combination with storm and strong winds the water level can rise by over a meter (Sjöfartsverket, 2023).

In 2023, Gothenburg experienced rainfall for 198 days (SMHI, 2023). In addition to that, heavy rains in Sweden are predicted to be more intense and frequent in the future, causing new extreme water levels (SMHI, 2017).

Klippan

Located along the river and marks the beginning of Gothenburg harbor lies Klippan, which became an important port location in the 17th century. It was the center of some of Sweden's biggest companies from that time, Ostindiska kompaniet and Carnegie's sockerbruk. The location was strategic for the companies since they needed to use the river for transport.

In 1965 Klippan became a cultural reserve as an initiative to preserve buildings from the industrial era. It includes a unique combination of buildings and has a high cultural and historical value. Materials such as wood, brick and stone represent the area.

Klippan area is partly protected by conservation programs, but the whole area is considered of national interest and as a valuable environment (Lönnroth, 1999).

The aim of the thesis is to adapt historical buildings in Klippan in a sustainable way to preserve them in a future of rising sea levels.



Klippan, November 2019

Methods and tools

The thesis utilizes a variety of methods and tools.

The case study method is useful for the process as it originates from an area of concern and gathers information through observations and analysis. It is used as an exploratory research tool for the thesis, which design proposals originate from.

The thesis process incorporates scenarios as a method, which is an important aspect.

By visualizing different future scenarios, this method serves as a stepping stone in the process that leads to the choice of strategy and design.

Both physical and digital models are placed in different scenarios of high water levels, a process of exploration used to generate proposals that respond to the research question.

The main design tool are retrofitting strategies, that are used as a guide for how to adapt existing buildings to rising sea levels.

Theory

Delimitations

The thesis does not consider possible future barriers that may prevent sea level rise within Gothenburg harbor.

Due to the specificity of the site and its buildings, this case study cannot provide general solutions for adapting to sea level rise.

The investigation and proposals will be based on a high water scenario of +2.8 m, which is estimated to occur during storms in 2100.

Reading Instructions

The booklet is divided into four sections.

Part 1 is an introduction to the subject and structure.

Part 2 is a chapter of investigation that contains mappings and an introduction of the buildings.

Part 3 showcases the retrofitting proposals which are based on the tools and information presented in parts 1 and 2.

Part 4 concludes the thesis and discusses the retrofitting proposals and outcome.

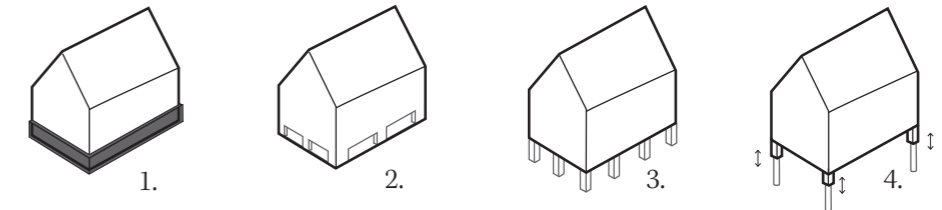

Retrofitting strategies

The thesis will be based on a set of strategies that exist as ways to flood proof or adapt a building to rising sea levels and flooding.

Retrofitting is modifying an existing building to protect it from flooding or events such as earthquakes and high winds.

Which retrofitting strategy to apply to a building can depend on factors such as flow velocity, cultural value, foundation or visual preferences.

1. Dry floodproofing

Dry floodproofing is a combination of measures which results in a structure being watertight and impermeable while structurally managing to resist flood loads (FEMA, 2014).

2. Wet floodproofing

Wet floodproofing allows water to enter the structure through openings resulting in flooding parts of the building, normally the basement or ground floor. The purpose of allowing water in is to prevent collapse due to high pressure (FEMA, 2014).

3. Elevation

Elevation prevents floodwaters from reaching the lowest floor by either elevating the entire structure or by constructing a new raised floor (FEMA, 2014).

4. Amphibious structure

A strategy that allows a structure to float on rising floodwater and adjusts to the current water level. A buoyancy system beneath the house displaces water to provide flotation when needed (FEMA, 2014).

Amphibious House

The amphibious House is made by Baca Architects and is situated along the river Thames. In the area of south Buckinghamshire most of the houses are raised about 1 m off the ground to protect them from flooding.

Due to the estimated future sea level rise the ground floor would need to be elevated 2,5 m above the ground.

Thanks to the house being an amphibious structure it allows the ground floor to be less than 1 m above ground instead of 2,5 m.

The utilities are connected by an elephant cabling. The flexible service pipes can extend up to 3m, allowing all of the services to remain operational during any flood event (Baca Architects, n.d.).

It is an interesting built reference for inspiration on how to use the amphibious strategy in an discrete way.

The reference is used for the investigation of the retrofitting of Sjömagasinet.

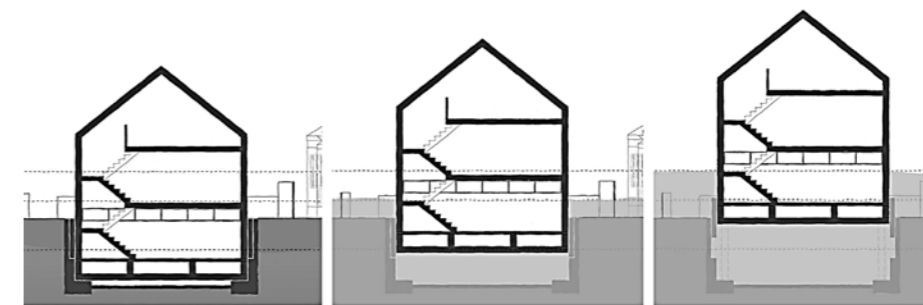
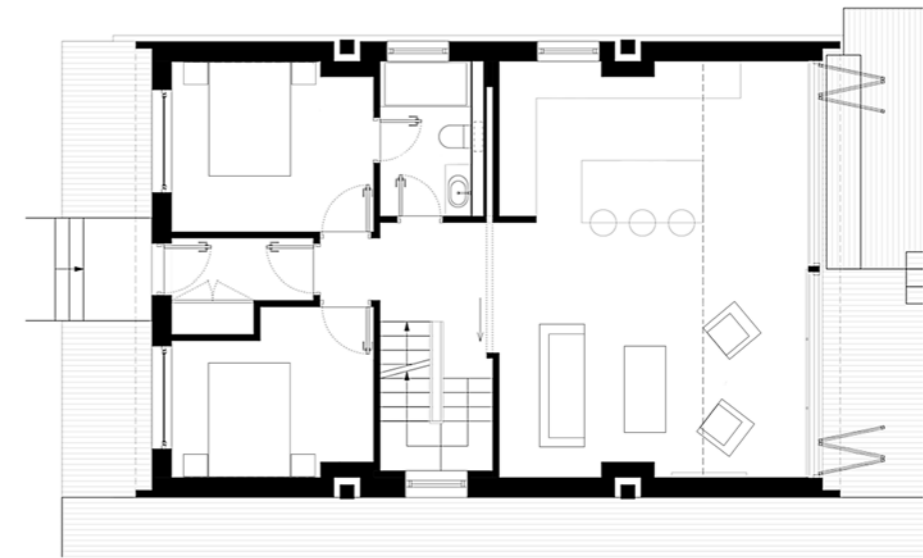

Cisternerne

Cisternerne is an old reservoir with 3 large rooms. It was built between 1856-59 and is an important part of Copenhagen's history.

Since 2013, Cisternerne has been a space for site-specific art created by artists or architects. The art projects cannot be reproduced anywhere else in the world.

The rooms in Cisternerne can hold up to 16 million liters of water with a maximum depth of 3.7 meters. This results in a humidity almost constantly close to 100%.

The walls are made of granite blocks, the floor and ceiling is concrete and the pillars are bricked (Fredriksbergmuseerne, n.d.).

It is used as a reference for Klippans konstcafé as inspiration on how to use a space for exhibitions that constantly changes due to water levels. The spaces also share similar building materials.



Le Relais Boréale Brewery

Atelier L'Abri transformed a concrete and glass commercial suite into a bar and brewery situated in Montreal, Canada.

The mezzanine above the cold rooms utilizes the double height, with the stainless-steel fermenters positioned on top.

The production space are highlighted by a large glass wall. Natural materials like local granite, wood, and lime plaster are used in the interior (Archdaily, 2023). The brewery is used as a reference for the new program for Klippans Konstcafé.

Program

dining area	120
brewing hall	60
cold room	44
technical area	38
bar	25
kitchen	14
restroom	12
mechanical room	8
shop	8
entrance	6
staff	6
utility room	3
total	750 (m²)

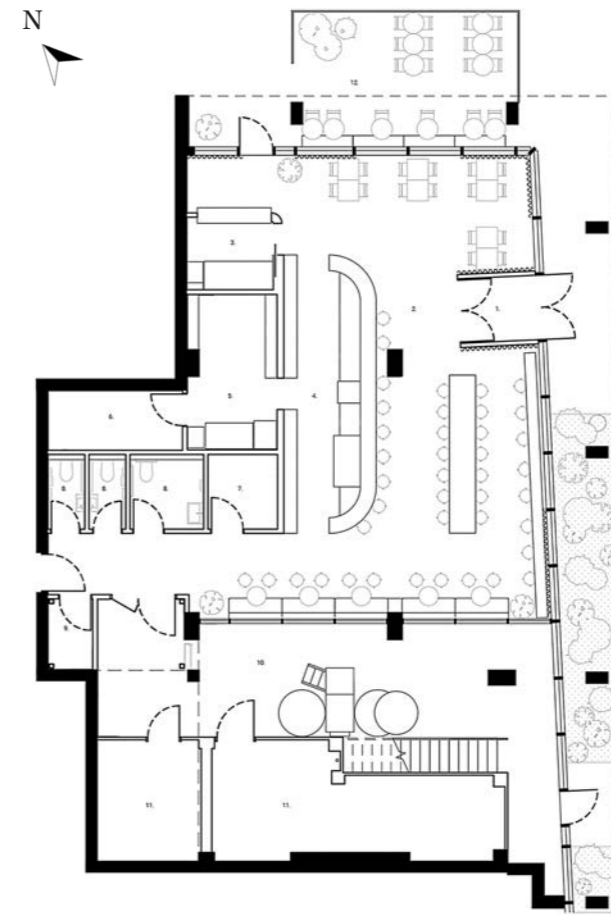
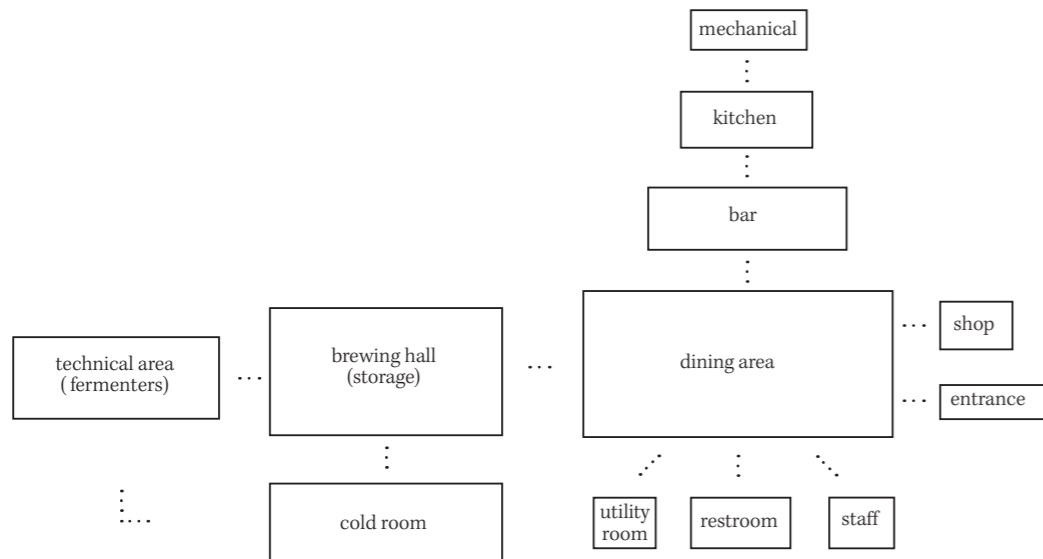

- | | |
|--------------------|------------------|
| 1. entrance | 7. staff |
| 2. dining area | 8. restroom |
| 3. shop | 9. utility room |
| 4. bar | 10. brewing hall |
| 5. kitchen | 11. cold room |
| 6. mechanical room | 12. terrace |

Investigation

Flooding simulations

Site analysis

Sjömagasinet

Klippans Konstcafé



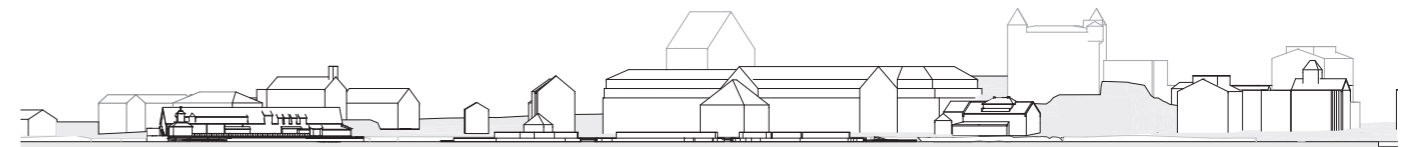
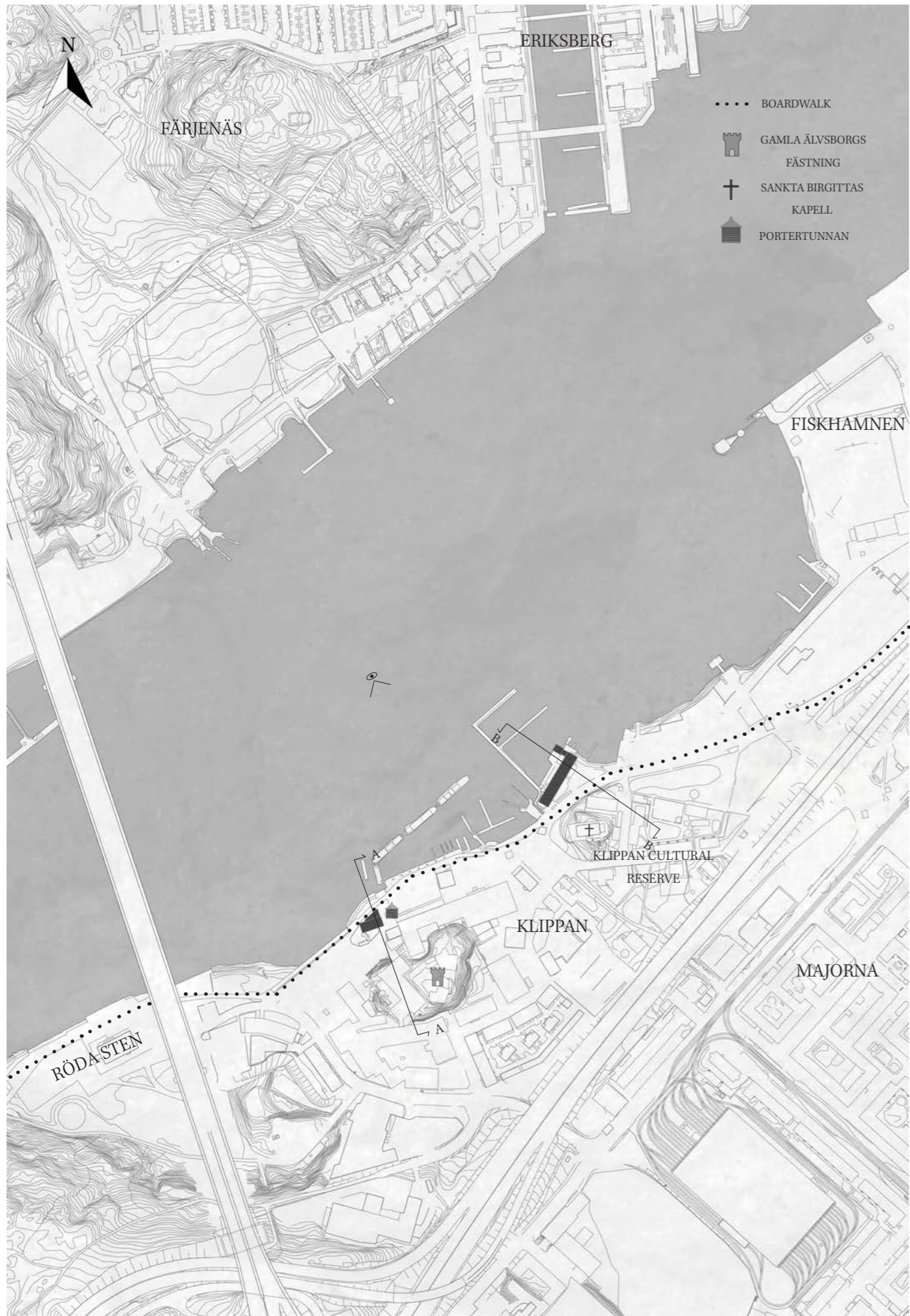

VIEW FROM GÖTA ÄLV

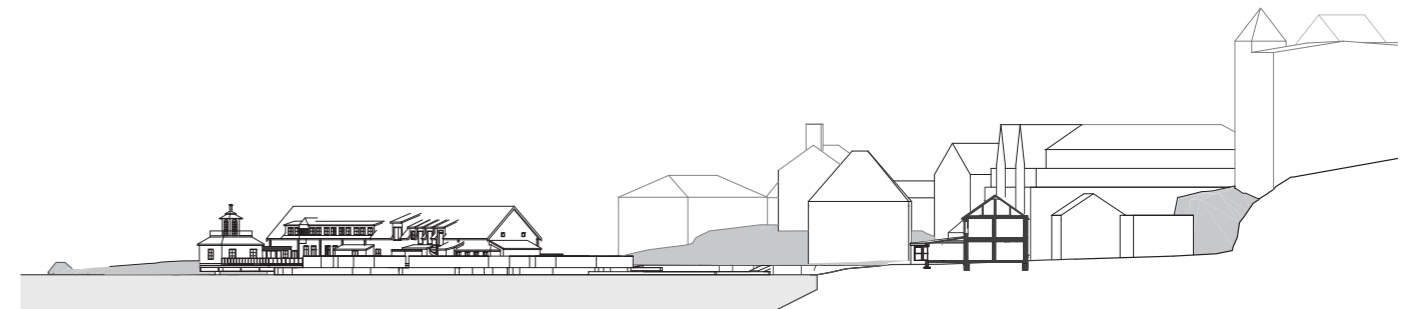

SECTION A-A

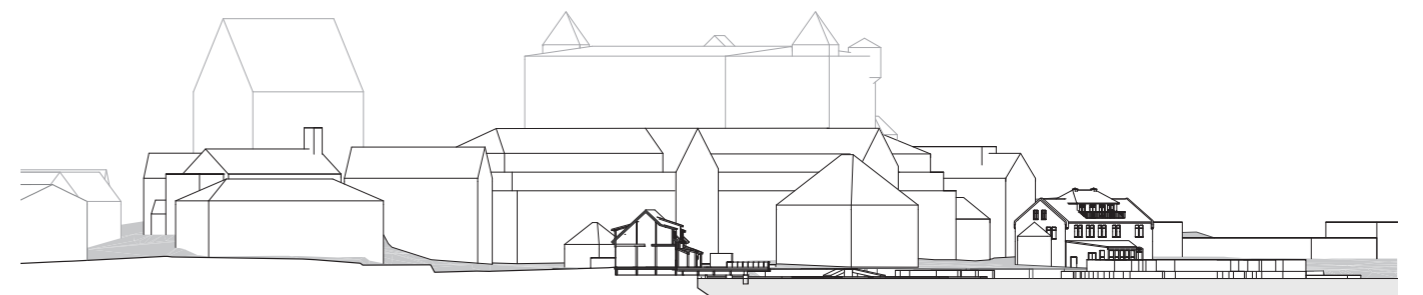

SECTION B-B



Flooding simulations

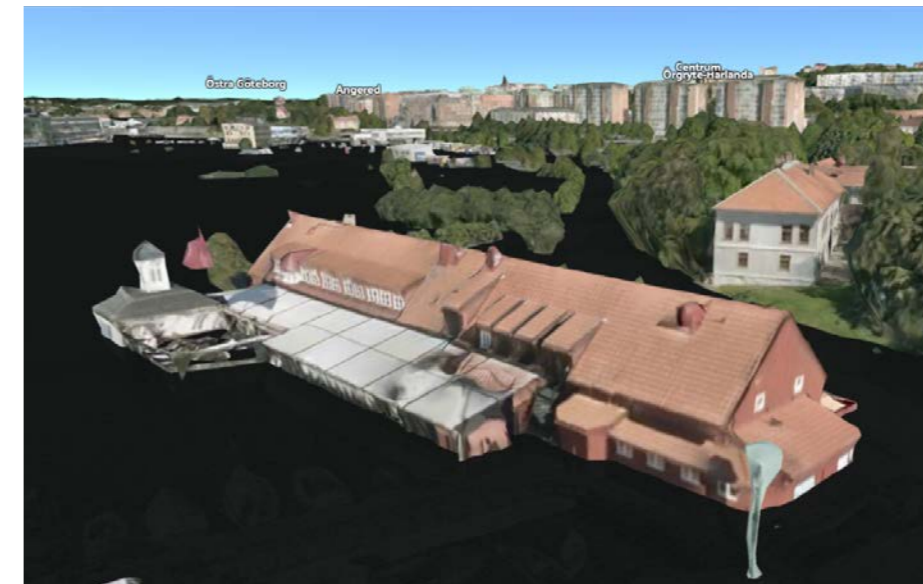
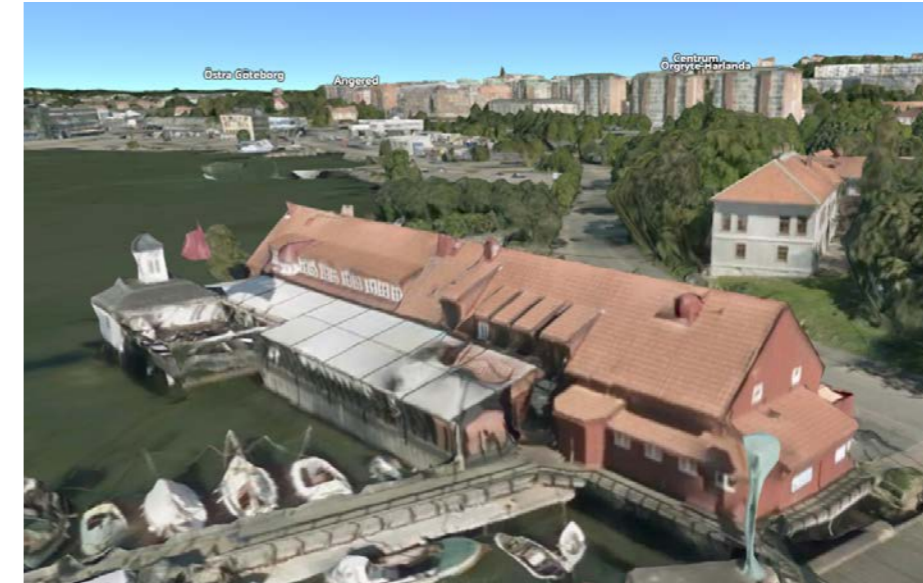



Context & Site analysis

Floodmapping

The tool Citiesplanner shows simulations of water levels in extreme weather scenarios when there is high amounts of rain and waves. Today, that level can be up to +1.8 meters above mean water level resulting in flooded parts of the boardwalk along the river.

In 2100, it is estimated that the mean water level will be approximately 1 meter higher resulting in +2.8 meter during storms. Figure 6-11 shows a comparison between the water level of today and the water level of 2100 during extreme weather (Göteborgs stad, n.d.)

Konstcafé & Sjömagasinet

Two buildings in Klippan that share the close relation to the shoreline and historical value is Klippans Konstcafé and Sjömagasinet. They both risk flooding by 2100 making them possible candidates for applying retrofitting strategies to.

They are interesting buildings that I find important to save, also motivated by the fact that they are included in the cultural reserve and national interest.

Conditions

The topography of the site is very flat in relation to the ocean with the exception of a few hills. The area between Konstcafé and Sjömagasinet varies mainly between 1-2.5 m in elevation. The site is therefore a high risk area for rising sea levels and is estimated to have parts flooded by 2100 (Göteborgs stad, 2023).

Characteristics of the area is the evident connection to water and its strong industrial history.

The boardwalk connects Klippan with areas along the river and both Konstcafé and Sjömagasinet are located along it. Weather conditions can be harsh due to minimal shelter from buildings and vegetation along the shoreline.

Today there are a lot of art studios encouraging craftsmanship and small businesses located in the old buildings. There are also hotels, restaurants and other businesses in the area.

Sjömagasinet



View of Sjömagasinet

One of the biggest buildings from Ostindiska kompaniets time is Sjömagasinet. It was built in 1775 from the drawings of Henrik Lieden.

It was strategically located right next to the water and was from the beginning designed as a "tyghus", a storage building for artillery pieces.

The building was originally divided into nine sheds with separate gates. It later became a boathouse and since 1983 it was replanned as a restaurant.

The site has also been through changes as it was originally a bay separating the south east side of the building from land. The building has slowly been sheltered from the water by surrounding structures.

Sjömagasinet is a long one story building with a furnished loft and a tiled gable roof with dormers. The building was built as a timber construction clad in a wood panel, with a base of stone pillars, prams and wood. (Lindälv, 1977). The foundation has since then been reinforced with concrete.



Scale 1:400

GROUND FLOOR

Investigation | 31

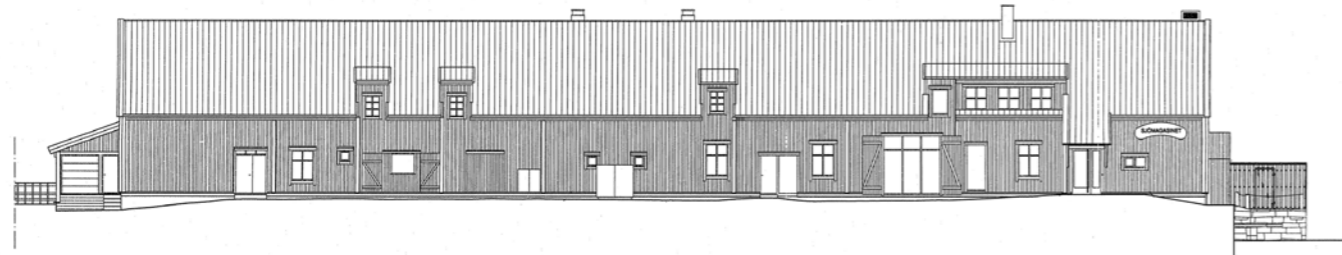

FACADE SOUTH EAST

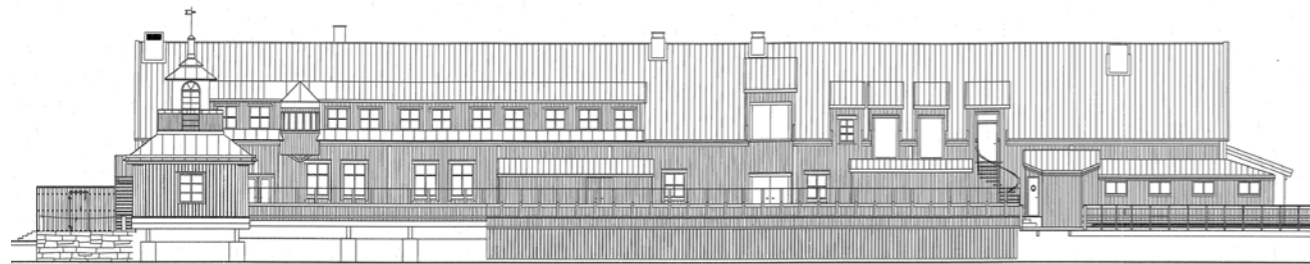

FACADE NORTH WEST

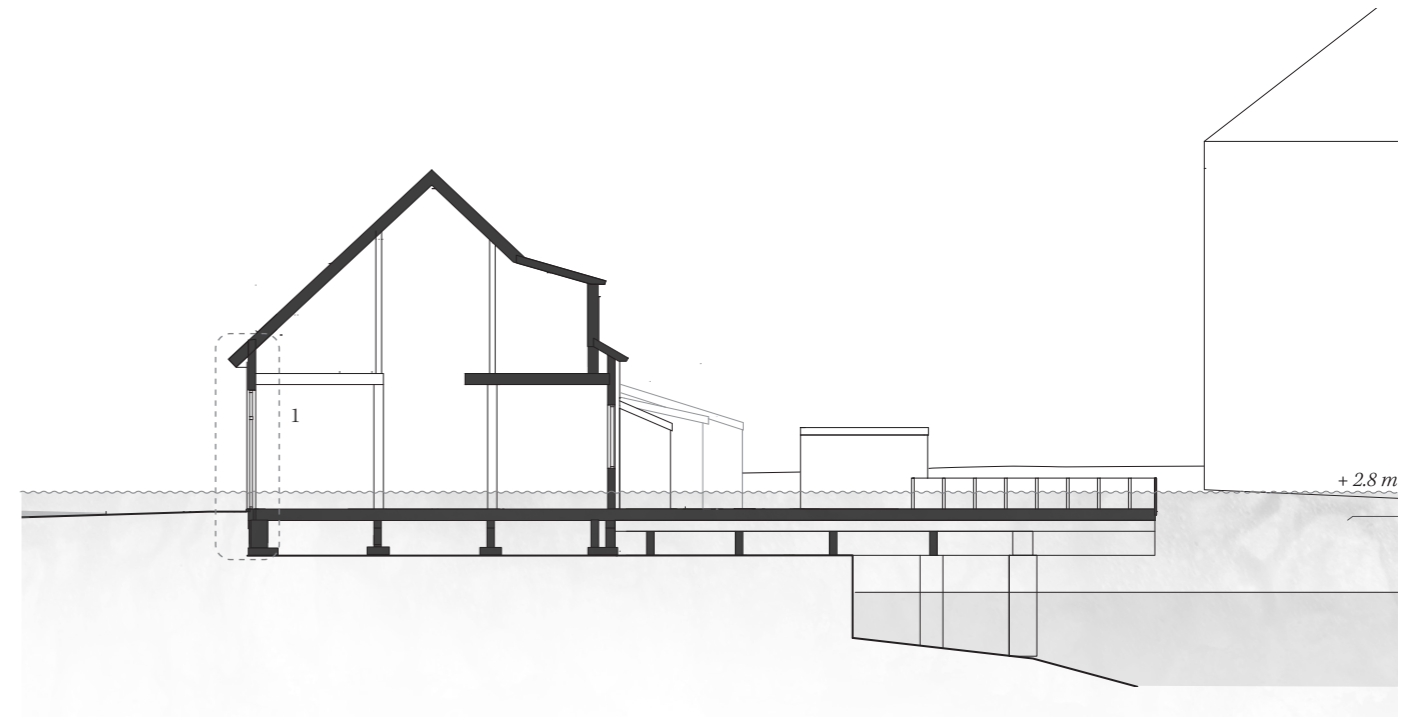

SECTION A-A

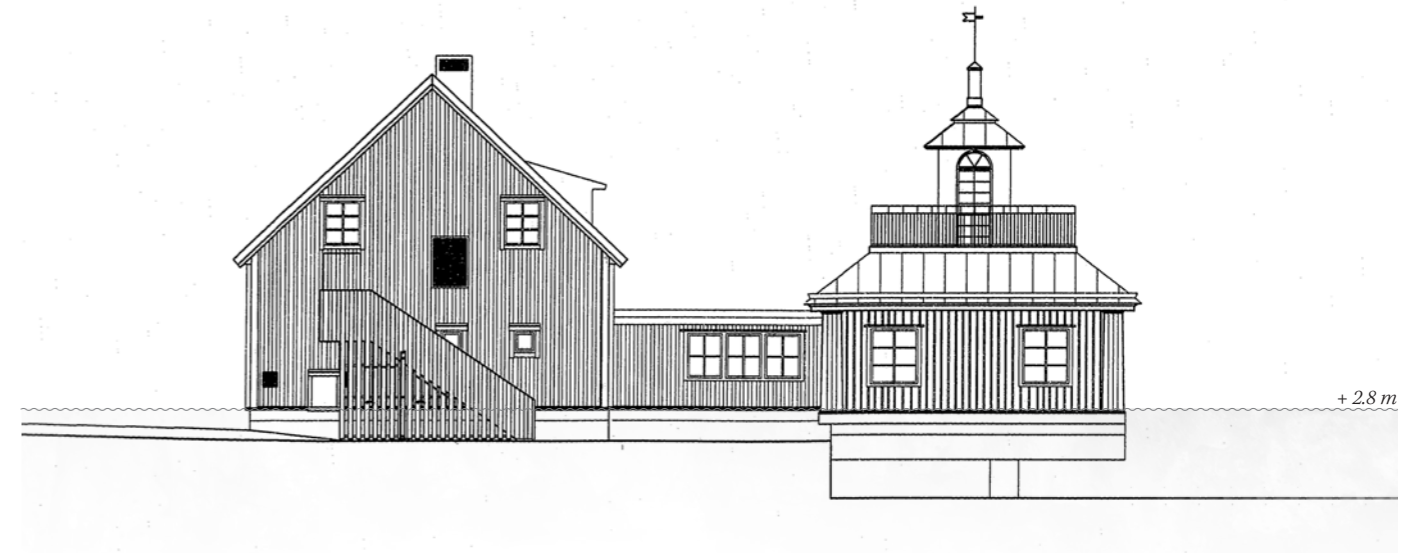

FACADE NORTH EAST

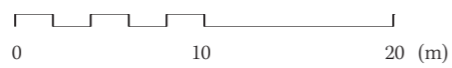

Klippans Konstcafé



View of Klippans Konstcafé

The sugar industry in Gothenburg had its breakthrough in the early 1900th century when it took over the site by Gamla Älvsborgs fästning.

Socketbruket area went through several alterations and additions until its operations ceased in 1957. One of the buildings that remains is the former office building located in the north end of the area (Lönnroth, 1999).

Today it is conducting a café and restaurant on the first floor and offices on floor 2 and 3.

The building recently had a new extension towards the water to increase the serving capacity for the café.

It is a brick building clad with a combination of smooth and textured light ochre plaster. The brick wall connects to a stone wall foundation. Since its construction, the foundation has been reinforced with concrete elements.

The interior has been altered several times and consist of mainly white walls and a combination of plastic and hardwood floors.



Scale 1:400

GROUND FLOOR

Investigation | 35

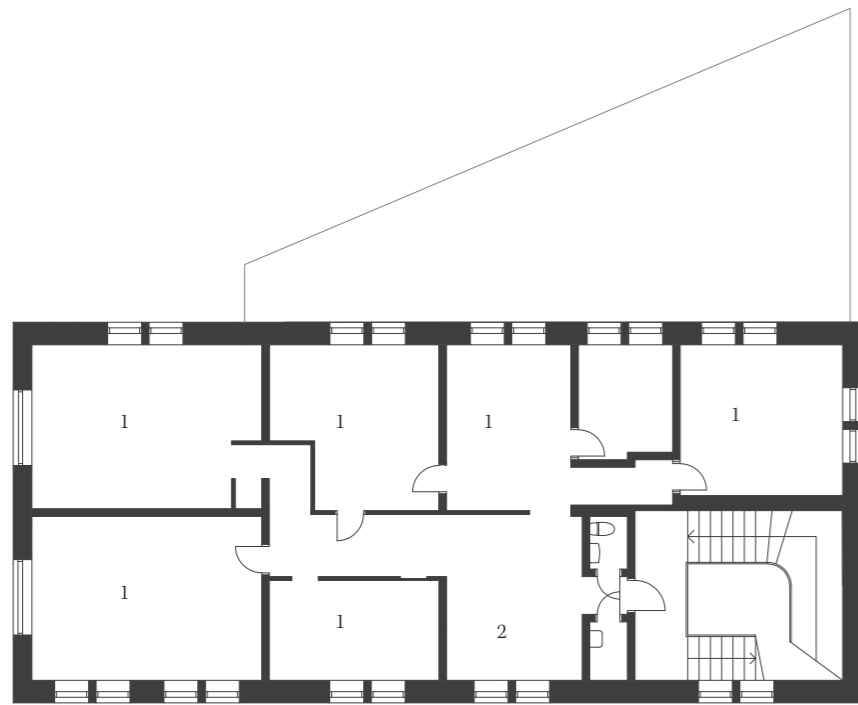

- 1. office
- 2. pantry

LEVEL 2

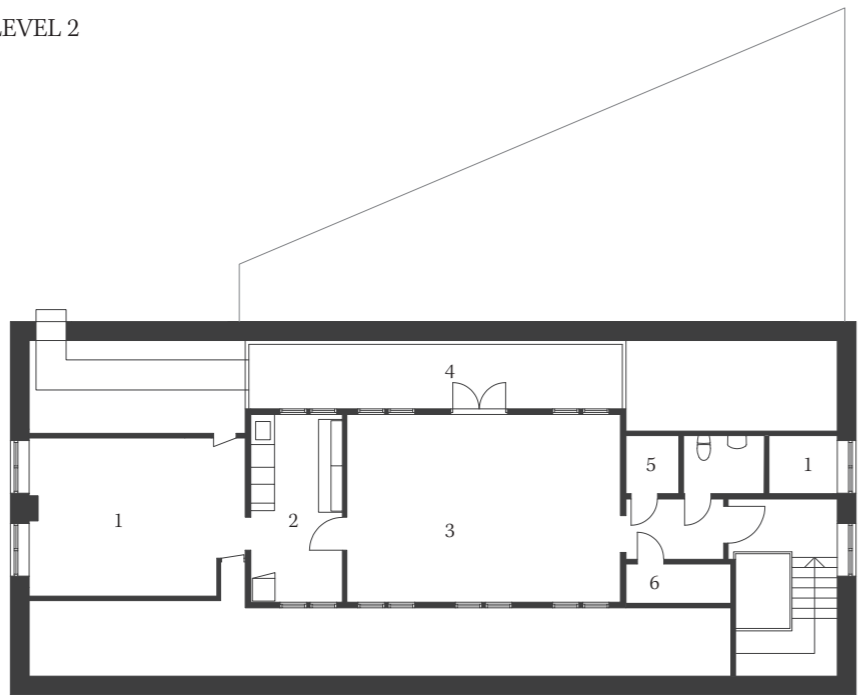

- 1. office
- 2. pantry
- 3. meeting
- 4. terrace
- 5. technical room
- 6. storage

LEVEL 3

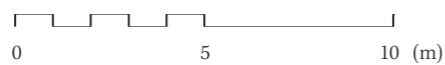

Scale 1:200



EAST FACADE

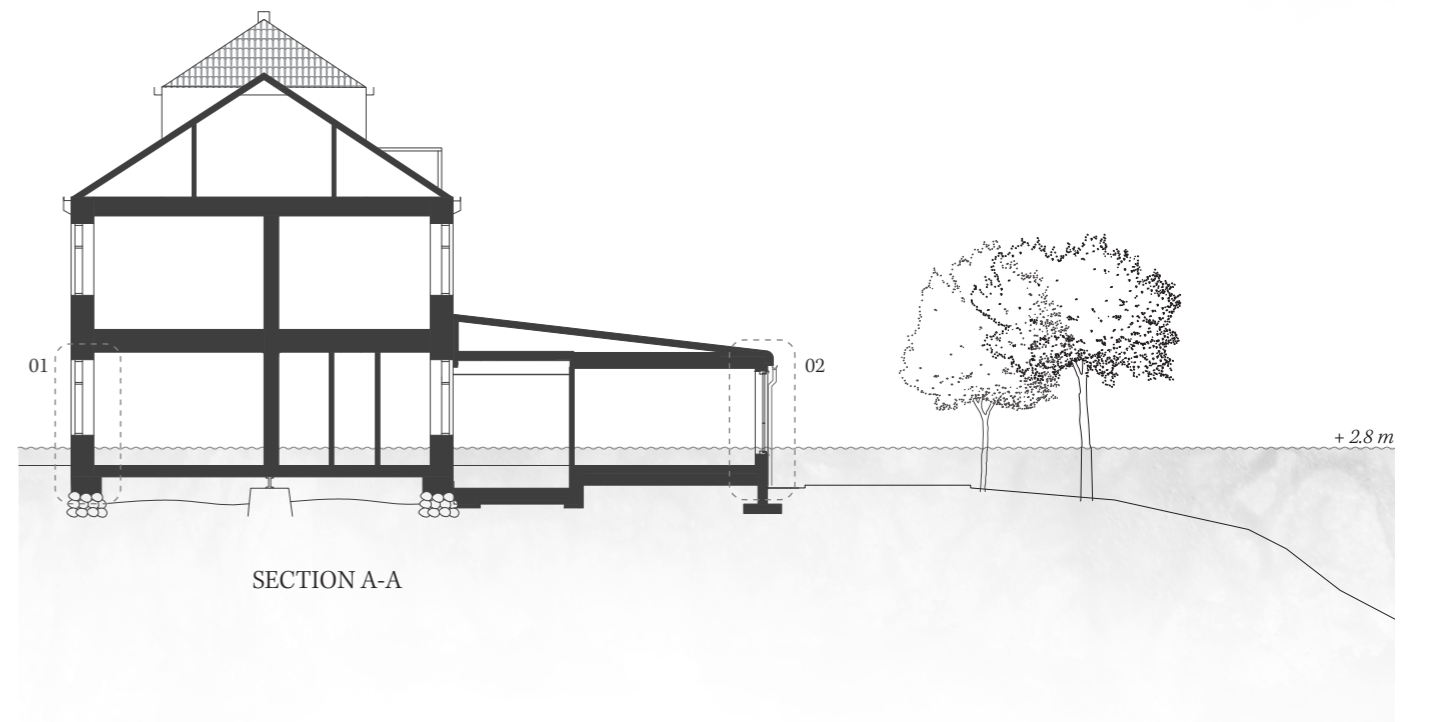

SECTION A-A

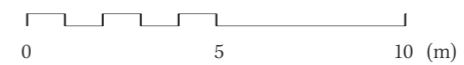

Scale 1:200



Retrofitting

Sjömagasinet x Amphibious

Klippans Konstcafé x
Wet floodproofing



Sjömagasinet x Amphibious



Sjömagasinet, October, 2023

Due to its role in the cultural reserve, Sjömagasinet cannot be moved from its placement in the landscape. Together with the wooden facade and structure, the amphibious strategy is proposed. The buoyant foundation is designed to be mounted onto existing structures to prevent damage caused by floods.

This strategy results in a program that remains unchanged with discrete modifications to the facade, as the added buoyant foundation is mostly below ground level.

There are three main components in a retrofitted buoyant foundation. The first component is the added buoyancy elements which make the building float by displacing water. The second addition is vertical posts that restrict horizontal movement, allowing the building to move up and down without floating away.

The final addition is a supporting structural frame installed beneath the existing floor. It holds the buoyancy elements in place and connects the whole structure to the vertical posts (English et al., 2021).

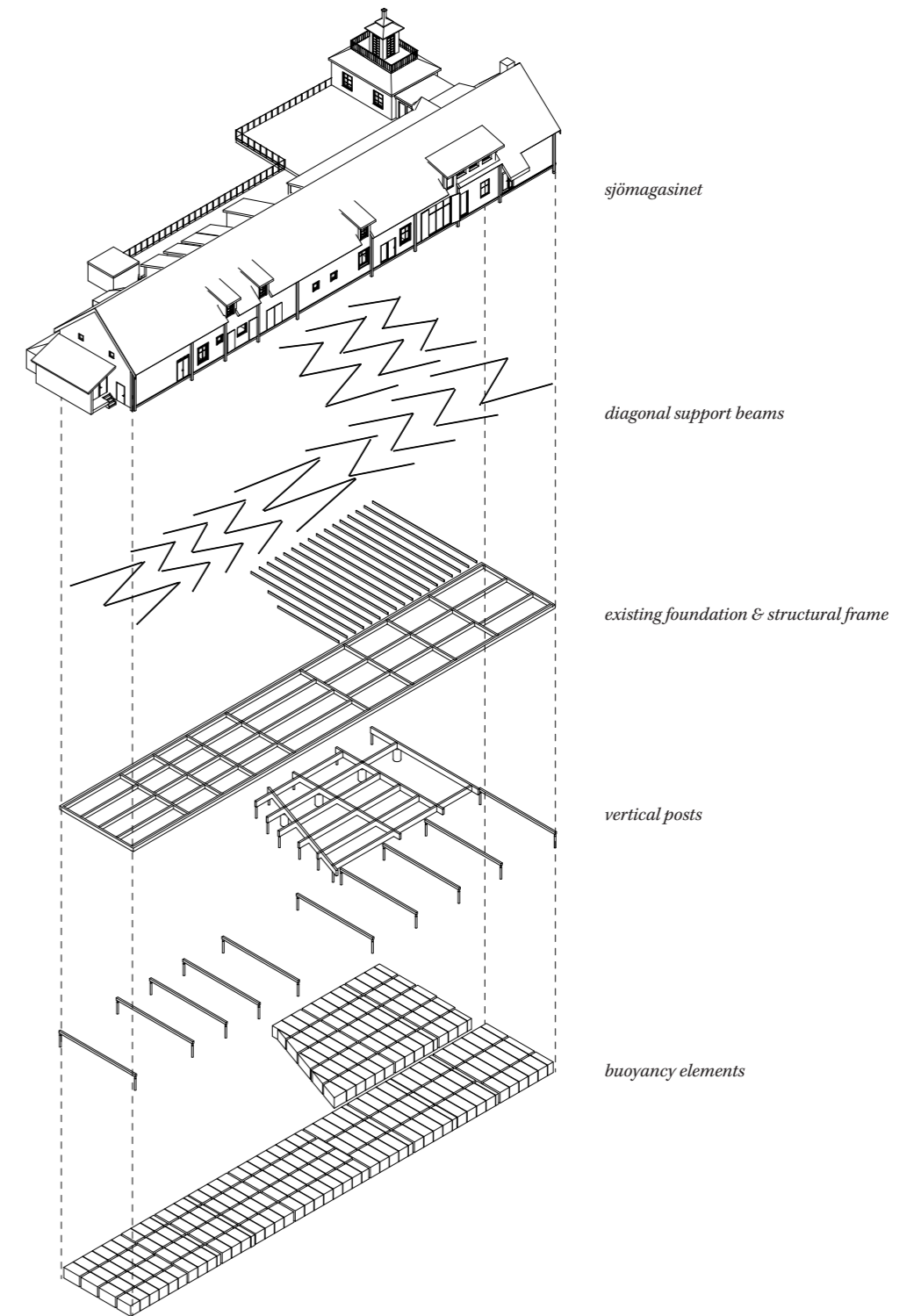

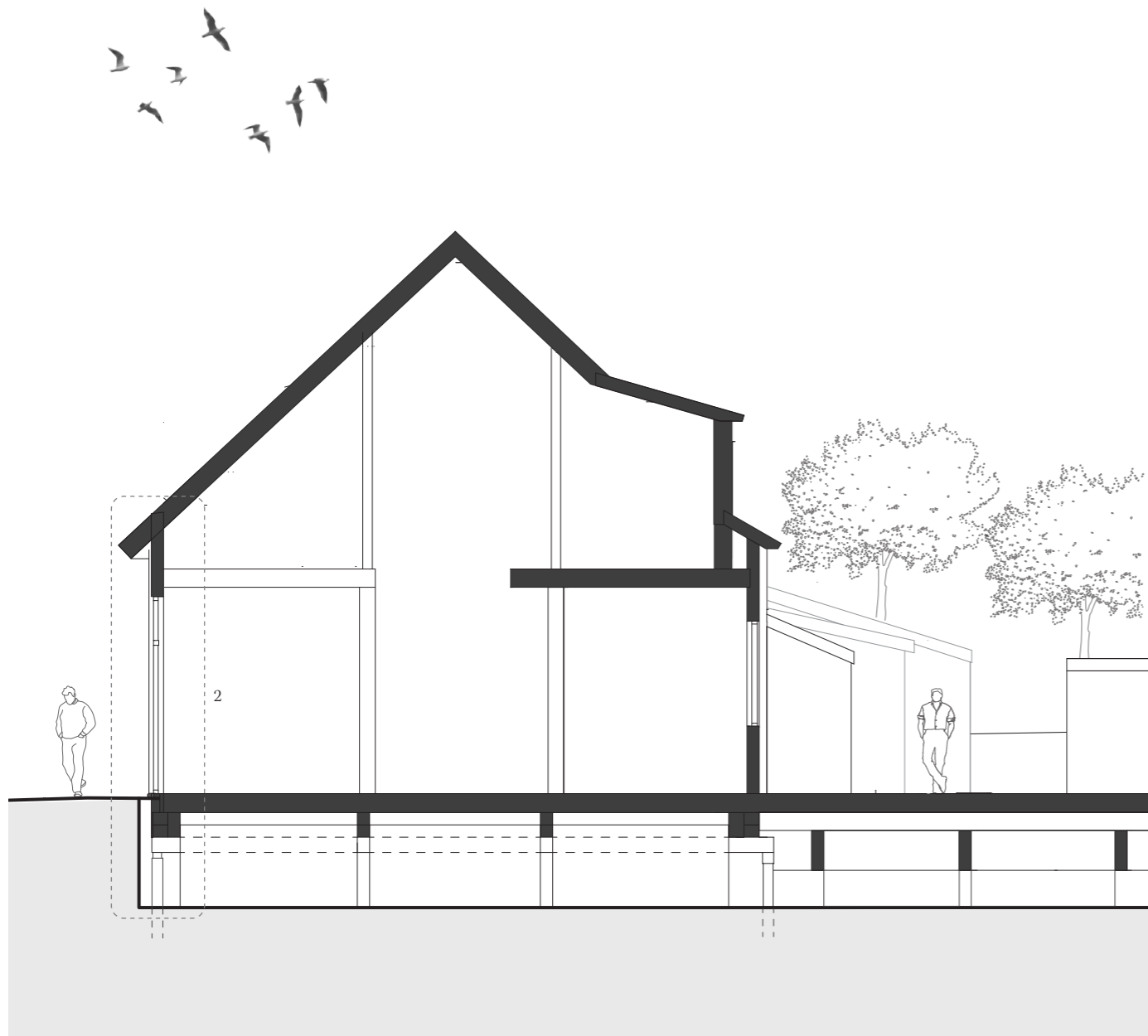

SECTION A-A

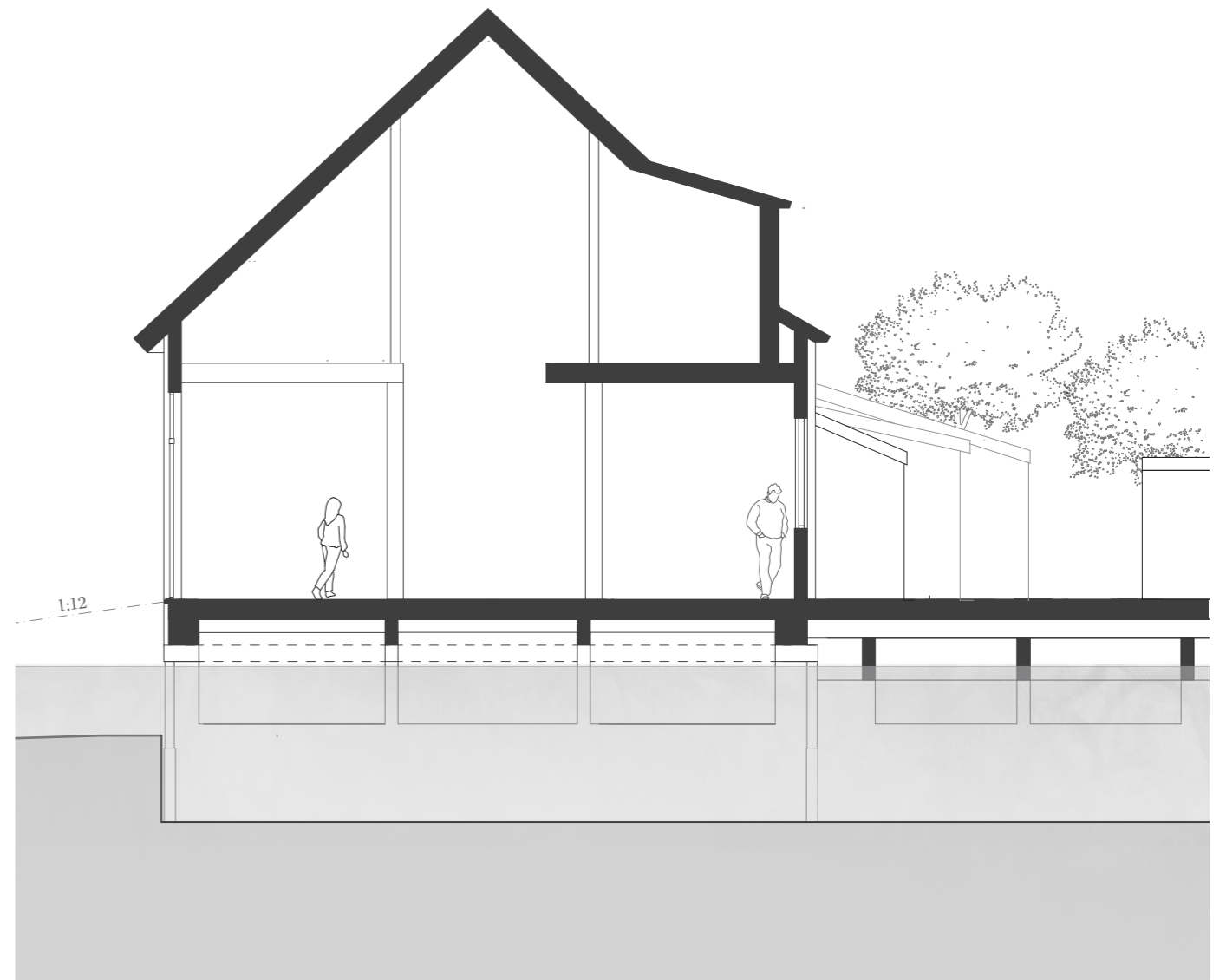

STORM SECTION A-A

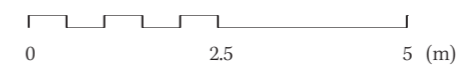
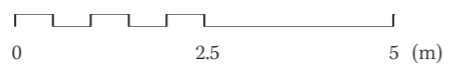

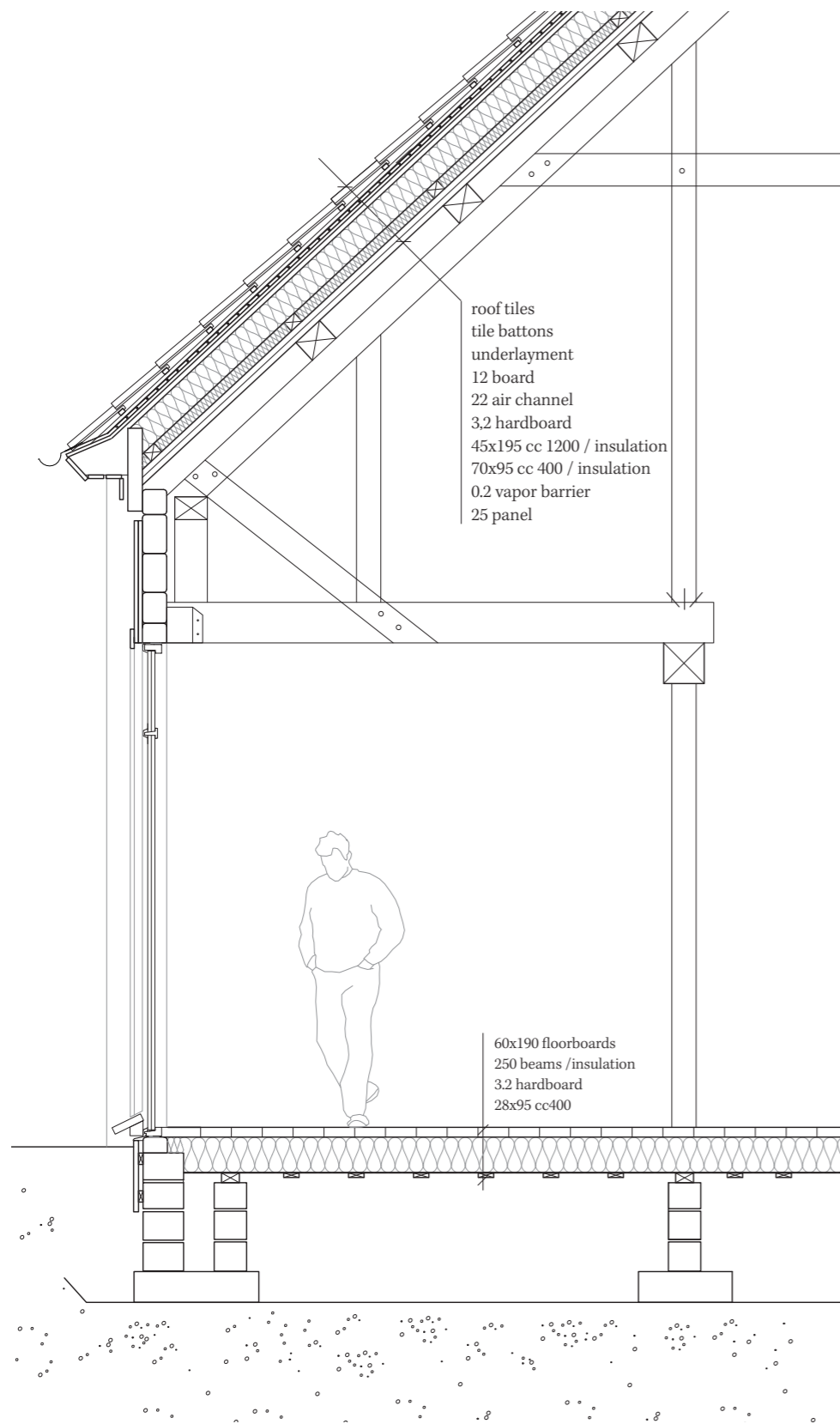

1. VERTICAL DETAIL

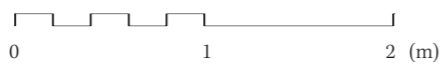

Scale 1:40

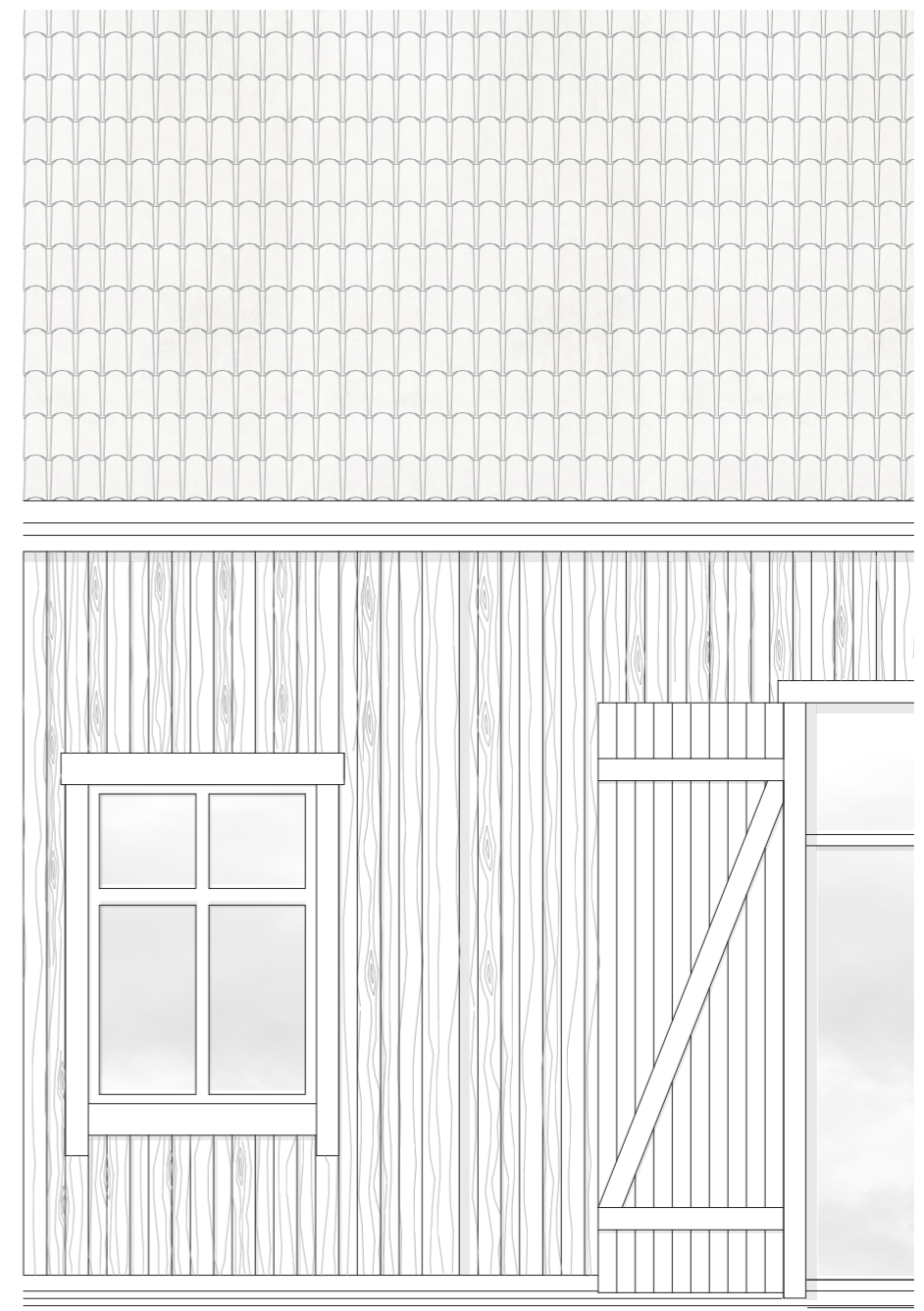

ELEVATION

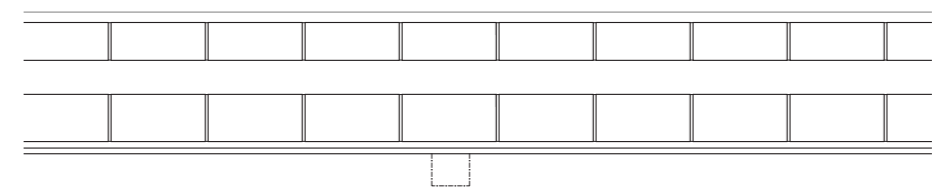

1. HORIZONTAL DETAIL

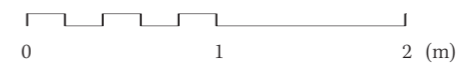

Scale 1:40

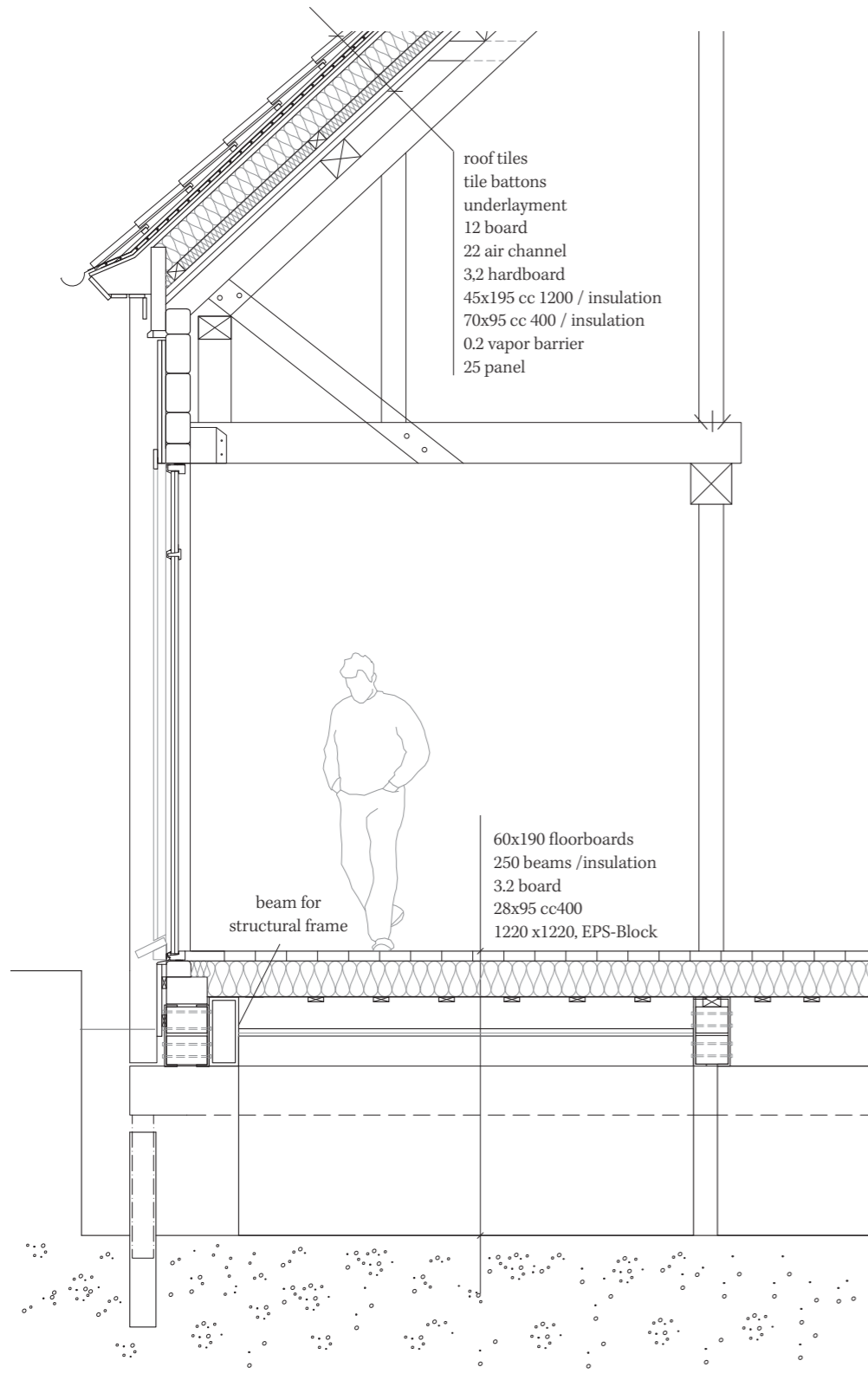

2. VERTICAL DETAIL

roof tiles
 tile battens
 underlayment
 12 board
 22 air channel
 3,2 hardboard
 45x195 cc 1200 / insulation
 70x95 cc 400 / insulation
 0,2 vapor barrier
 25 panel

beam for
 structural frame

60x190 floorboards
 250 beams /insulation
 3,2 board
 28x95 cc400
 1220 x1220, EPS-Block

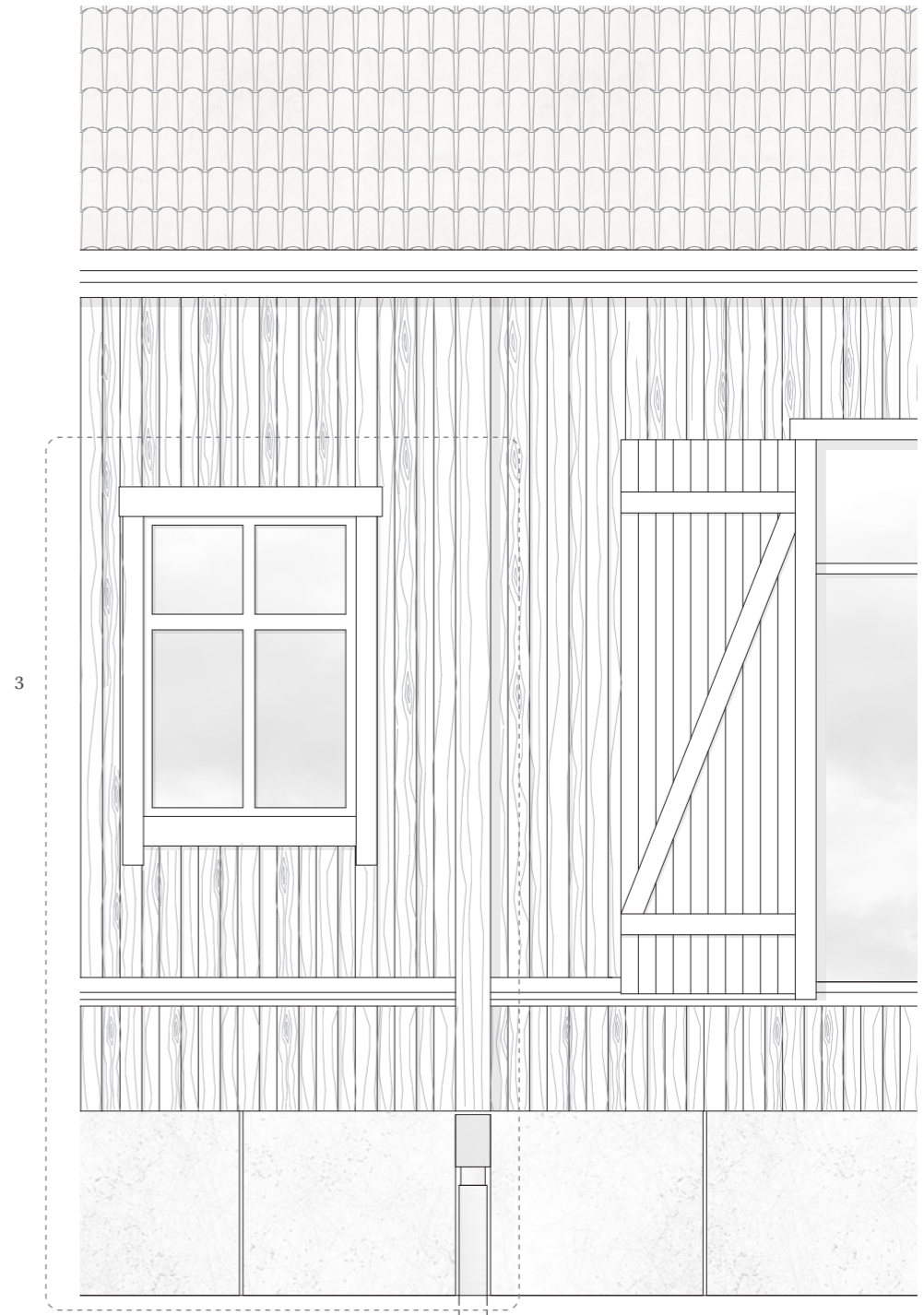
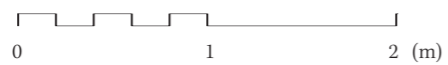

RETROFITTED ELEVATION

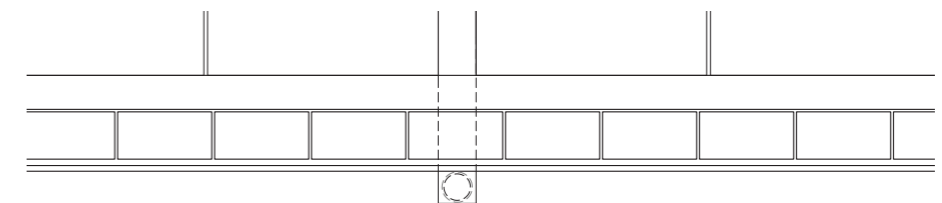

2. HORIZONTAL DETAIL

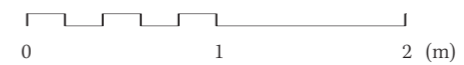

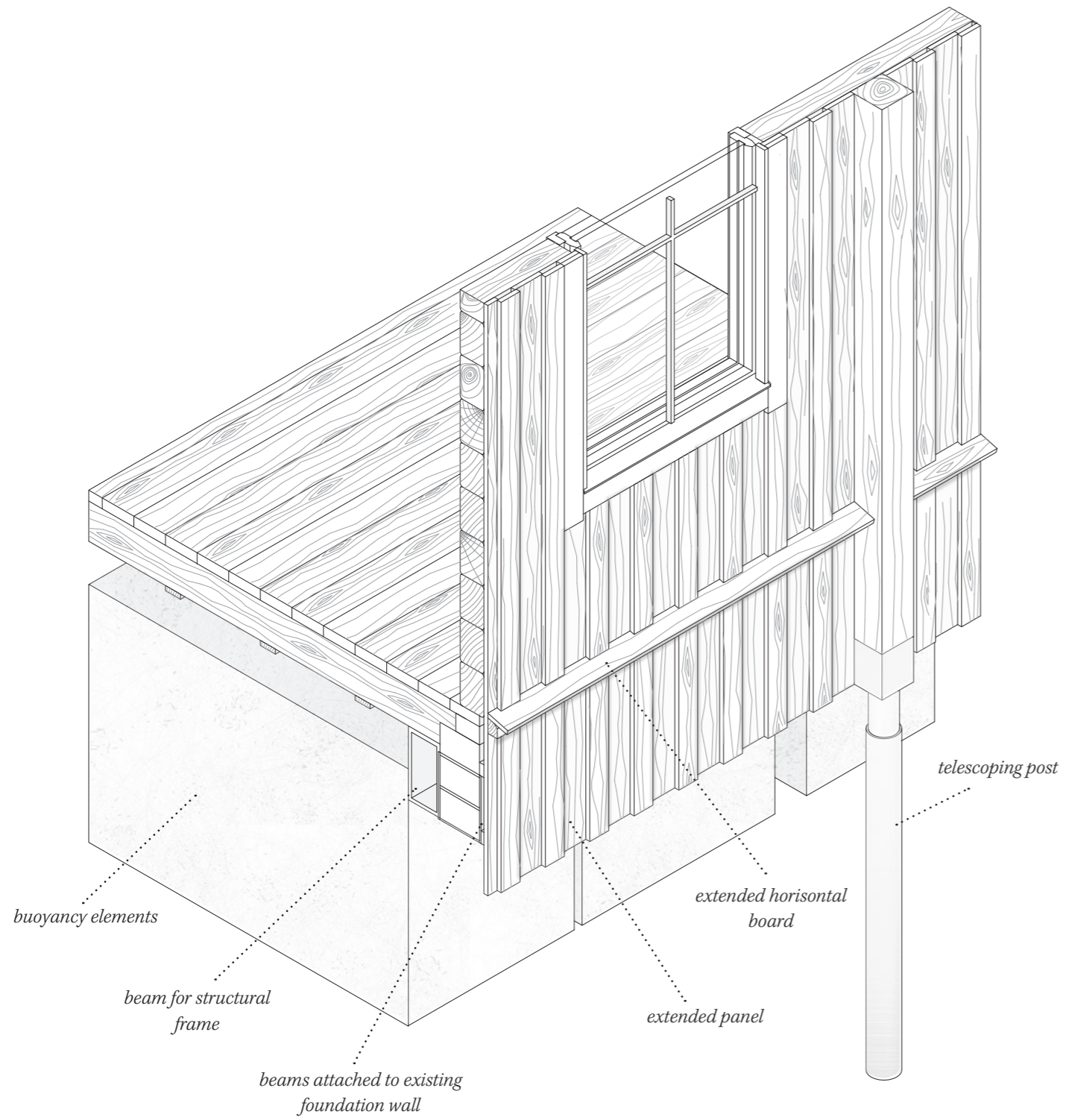

Klippans Konstcafé x Wet floodproofing



The suggested approach to use on Konstcafé is wet floodproofing which leads to a new program for the ground floor. A hollow structure where water and people can pass through is created by removing windows and doors and extending the openings to the ground.

The ground level is converted into an exhibition space dedicated to showcasing art installations. Elements within the structure are added to enable movement during high water levels. The space is not intended to be used during

storms, but rather after when waters might still be high. The area would be humid due to the almost constant presence of water.

In addition to the transformation of the ground level, a new program for levels 2 and 3 is also proposed. The new program is inspired by the history of brewing in the area and its location next to the old brewery building, Porterbruket, and the landmark Portertunnan. Leading to the proposal for a new restaurant and taproom for a local brewery.

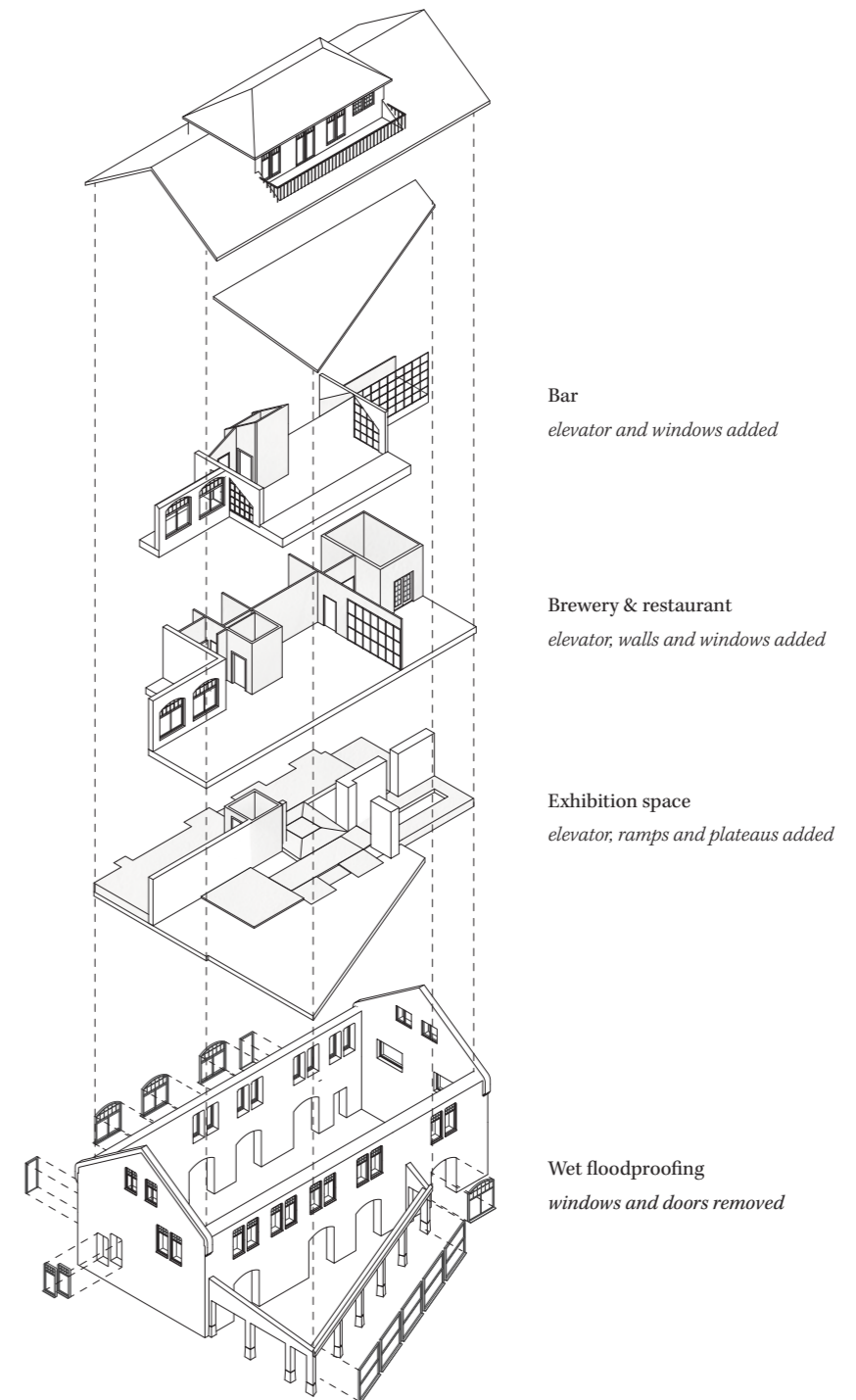

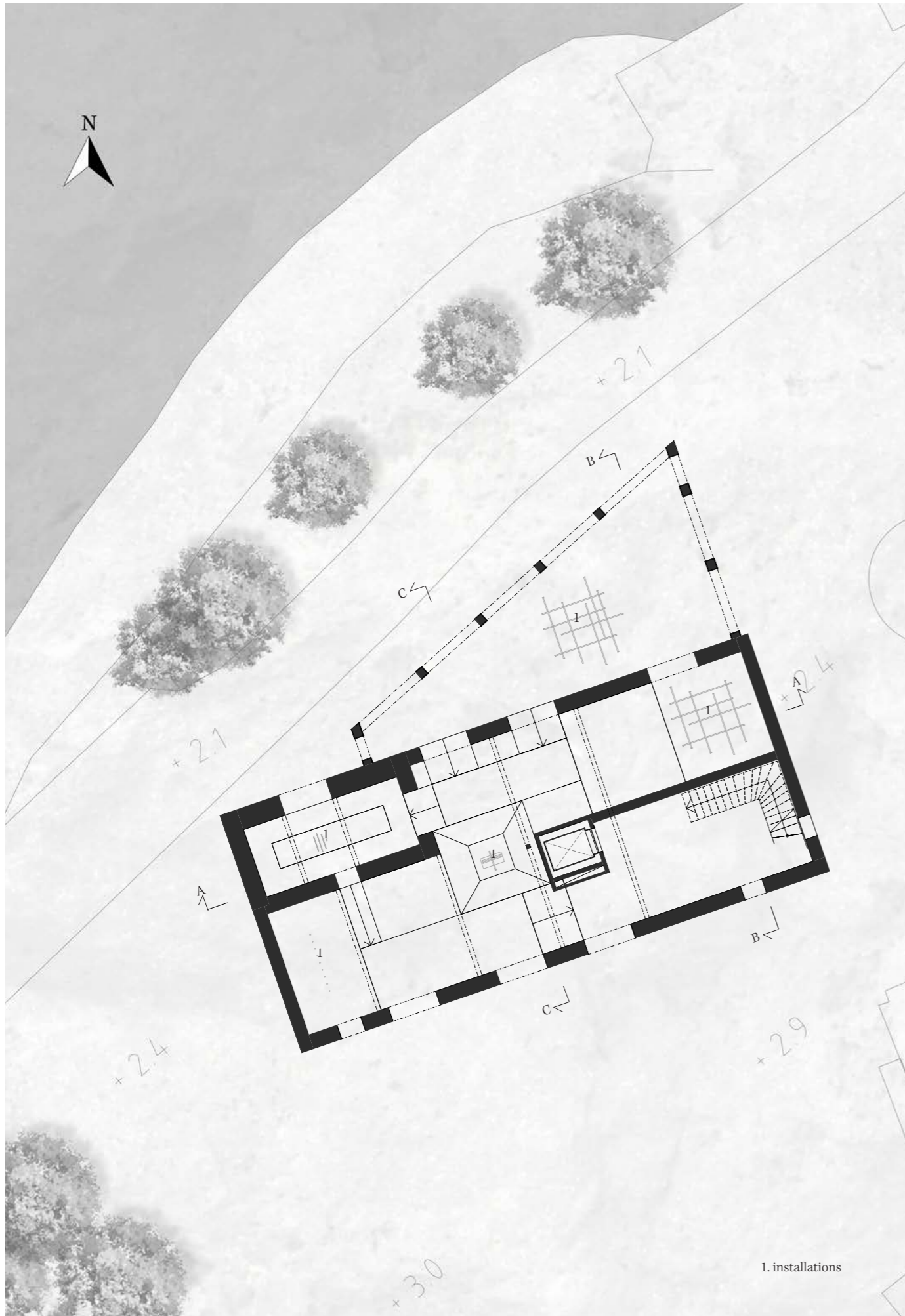

Program (m²)

Ground level	
exhibition	208
Level 2	
dining area	66
brewing hall	30
cold room	14
bar	13
kitchen	12
restroom	7
mechanical	6
Level 3	
dining	50
bar	5
restroom	2

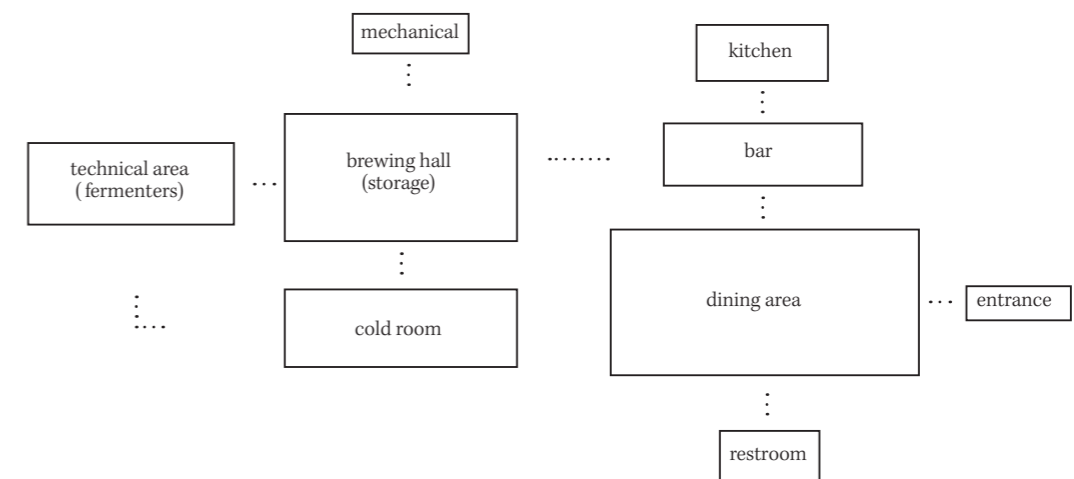

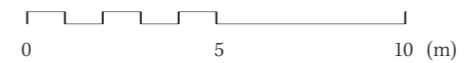
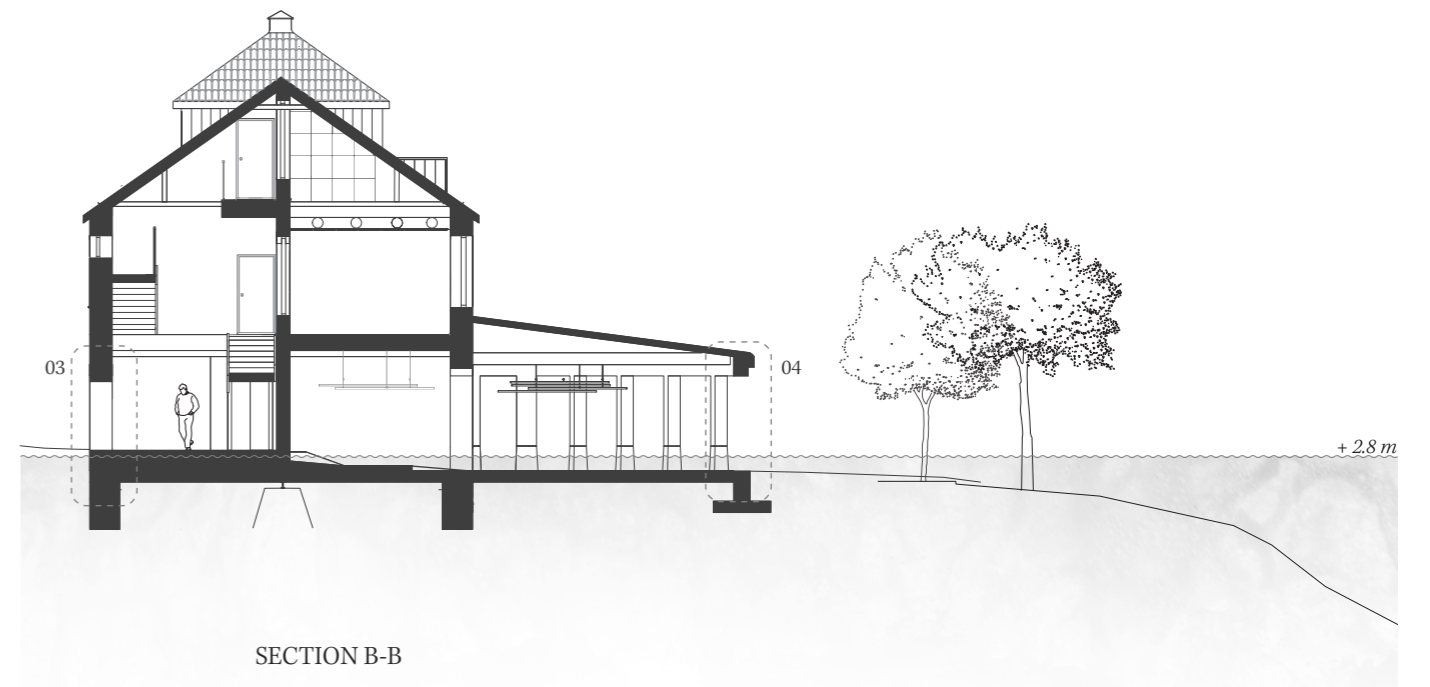
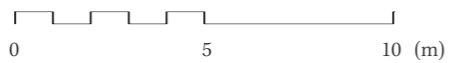



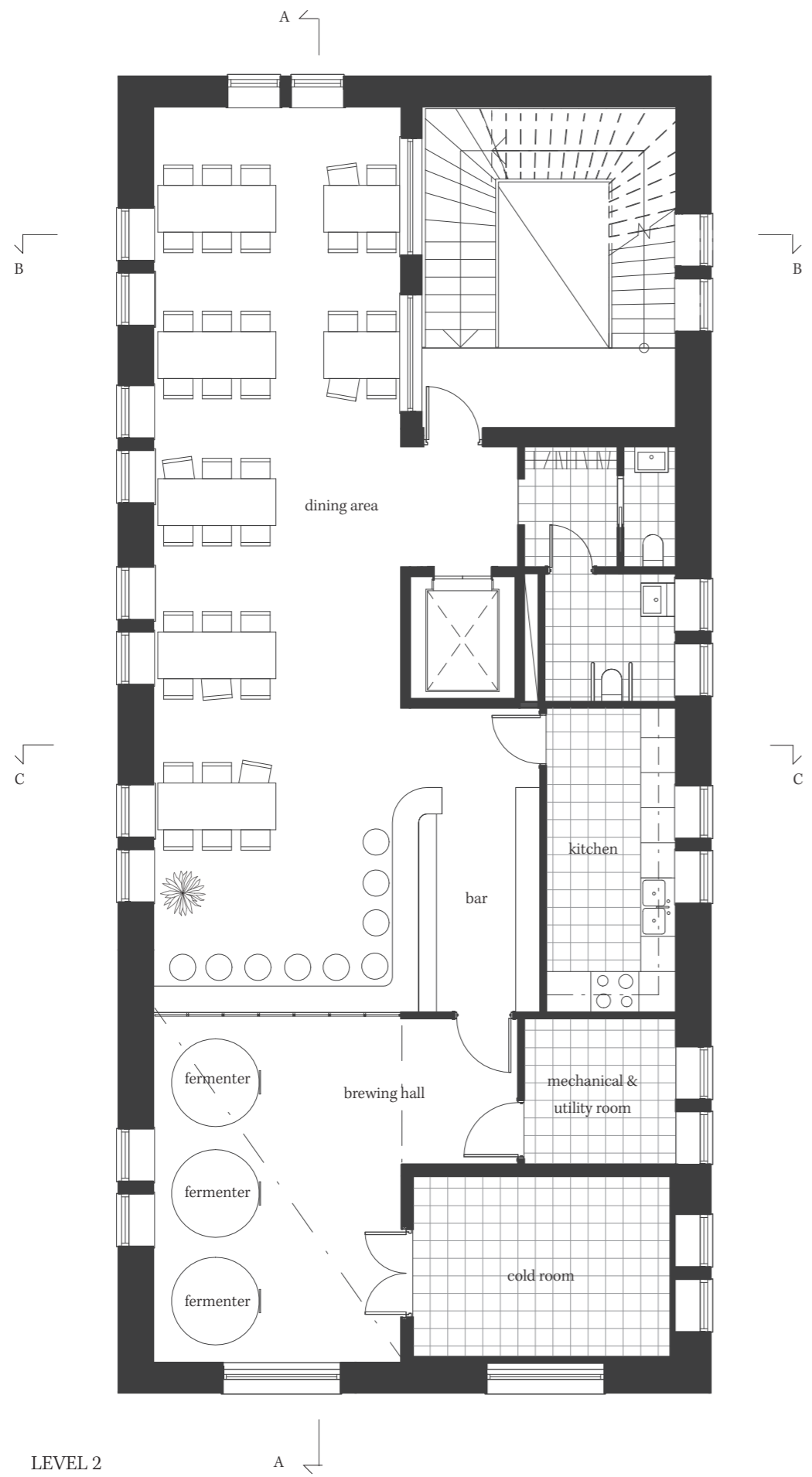

dining area level 2

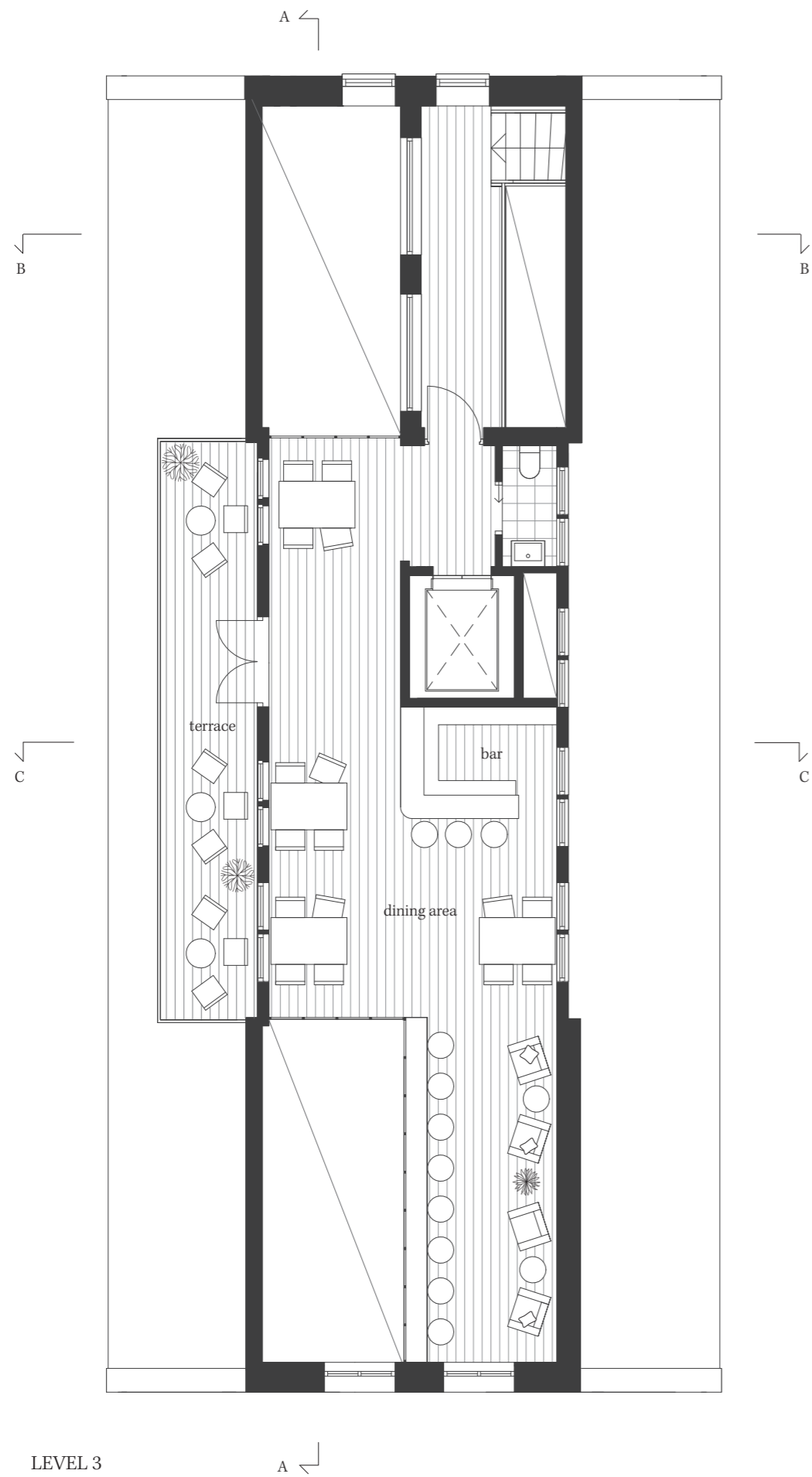

dining area level 3

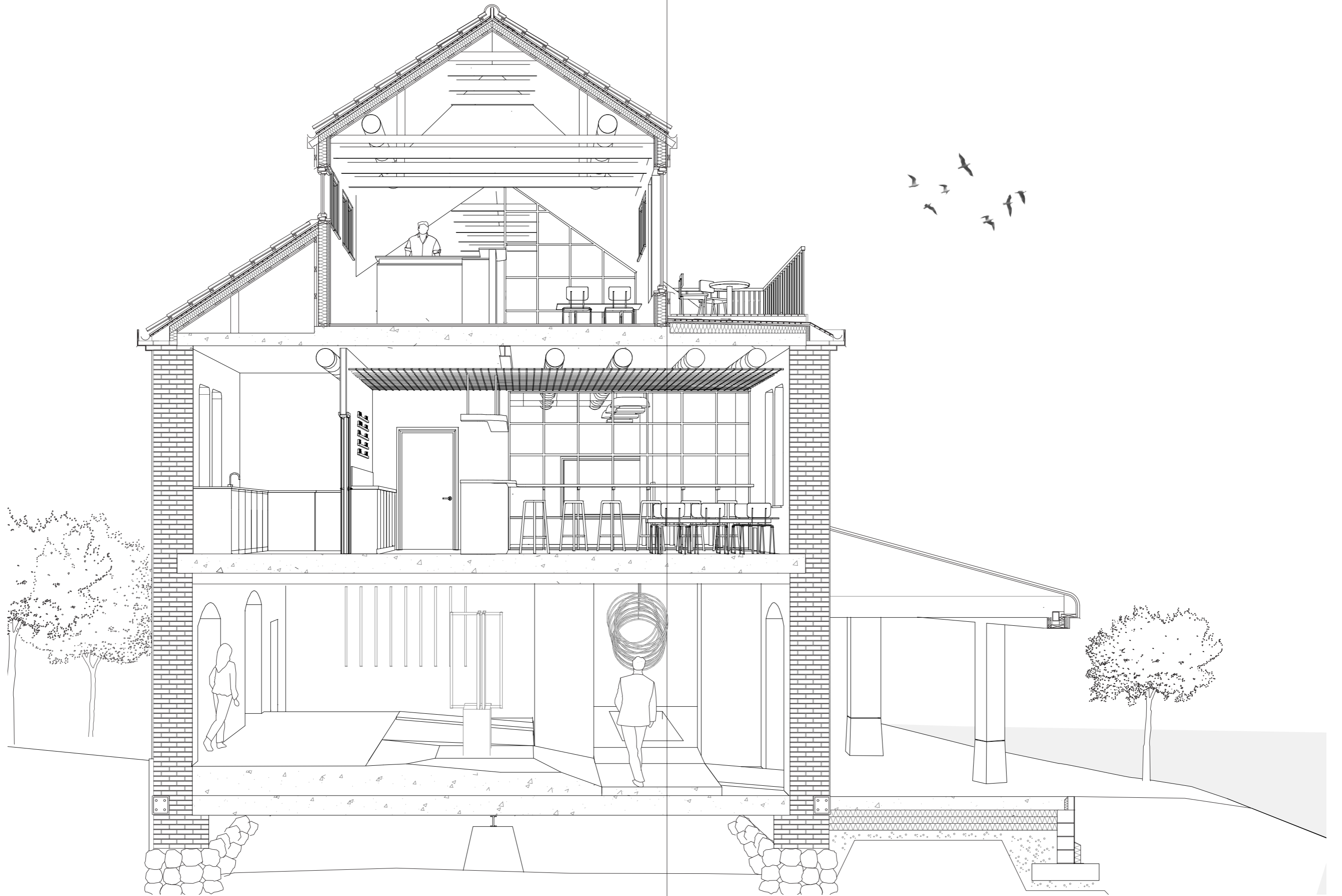



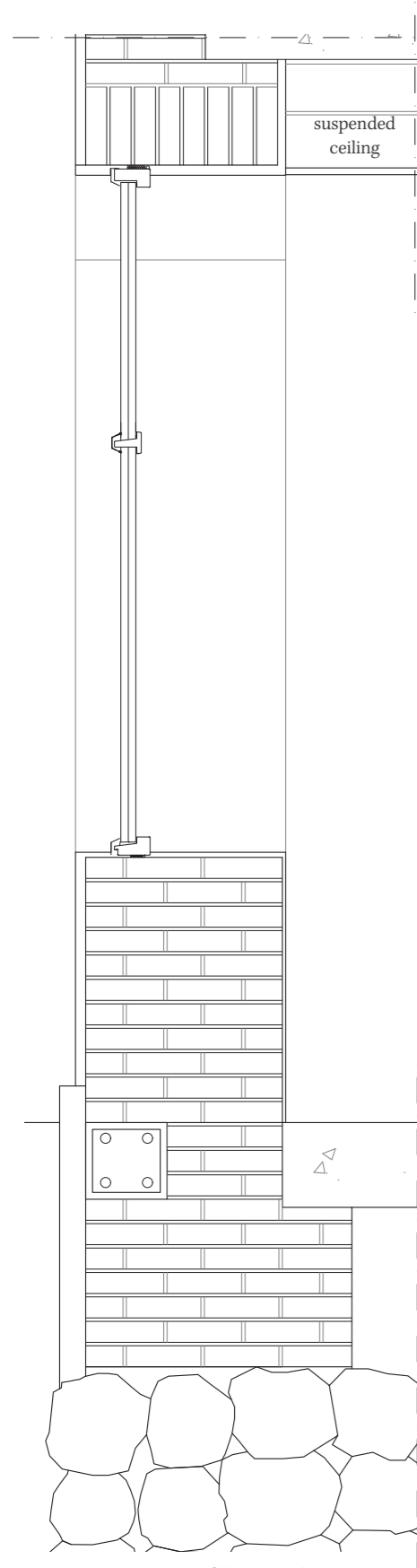

01. VERTICAL DETAIL

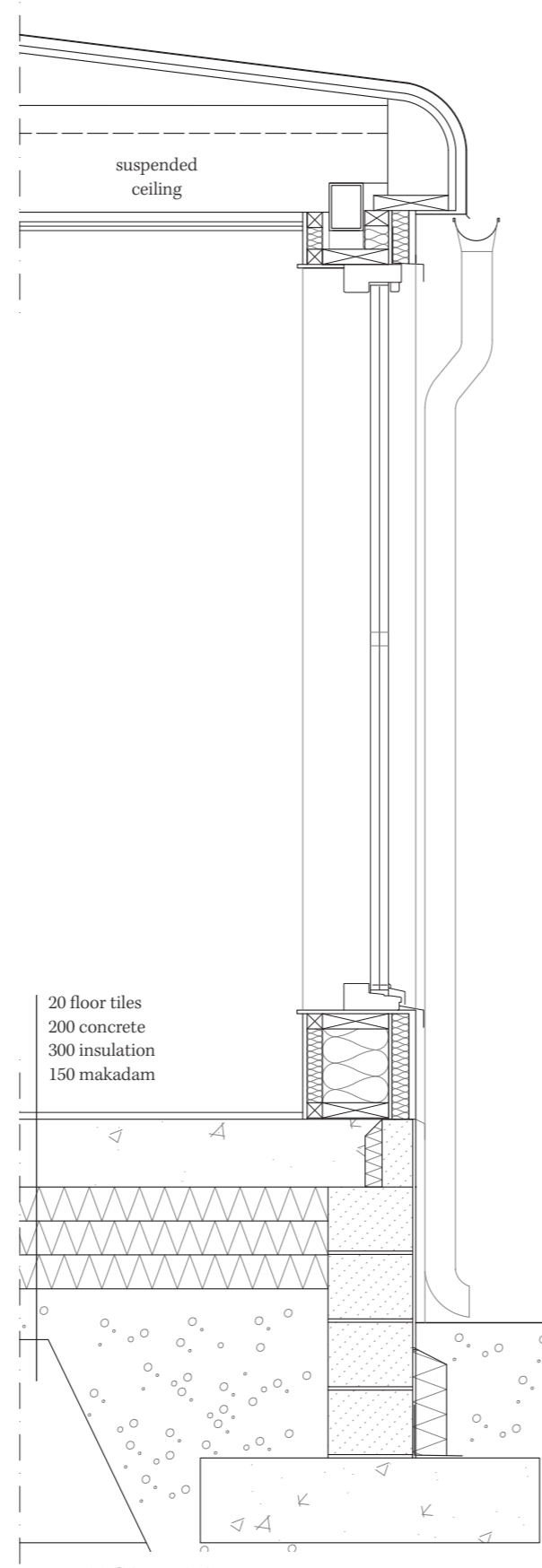

02. VERTICAL DETAIL

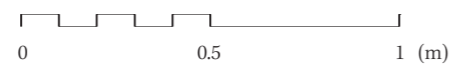

Scale 1:20



ELEVATION

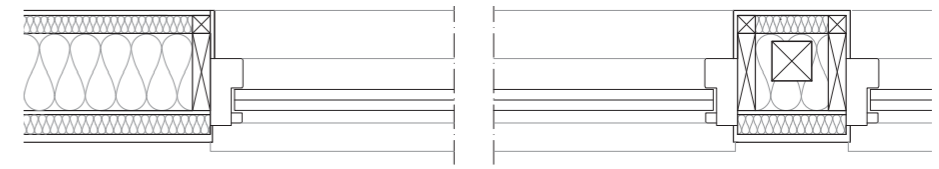

02. HORIZONTAL DETAIL

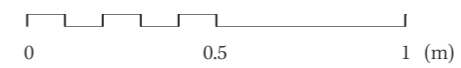

Scale 1:20

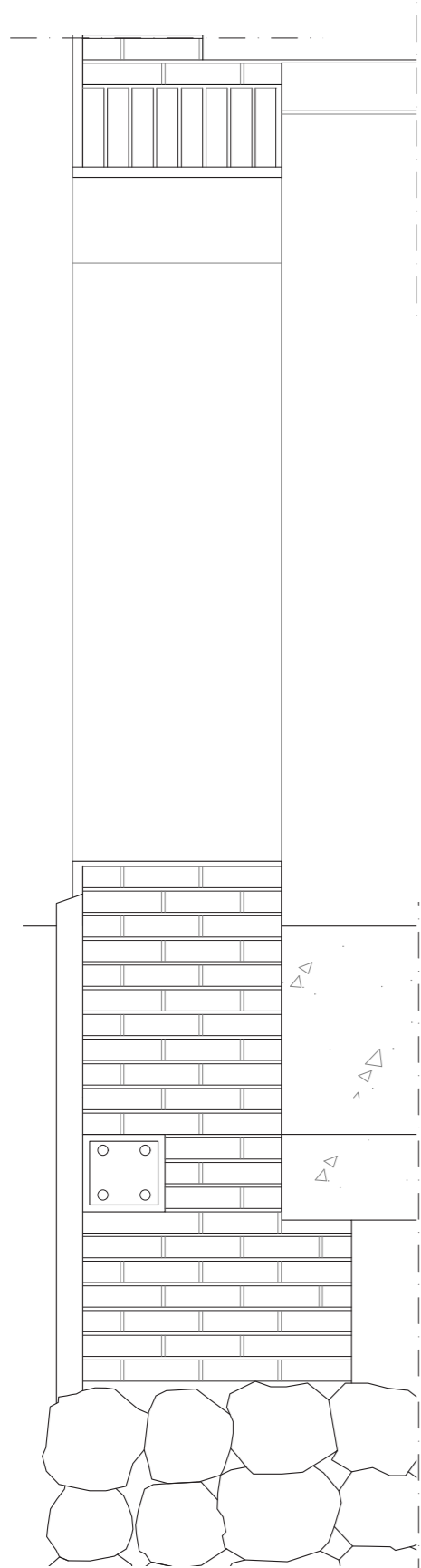

03. VERTICAL DETAIL

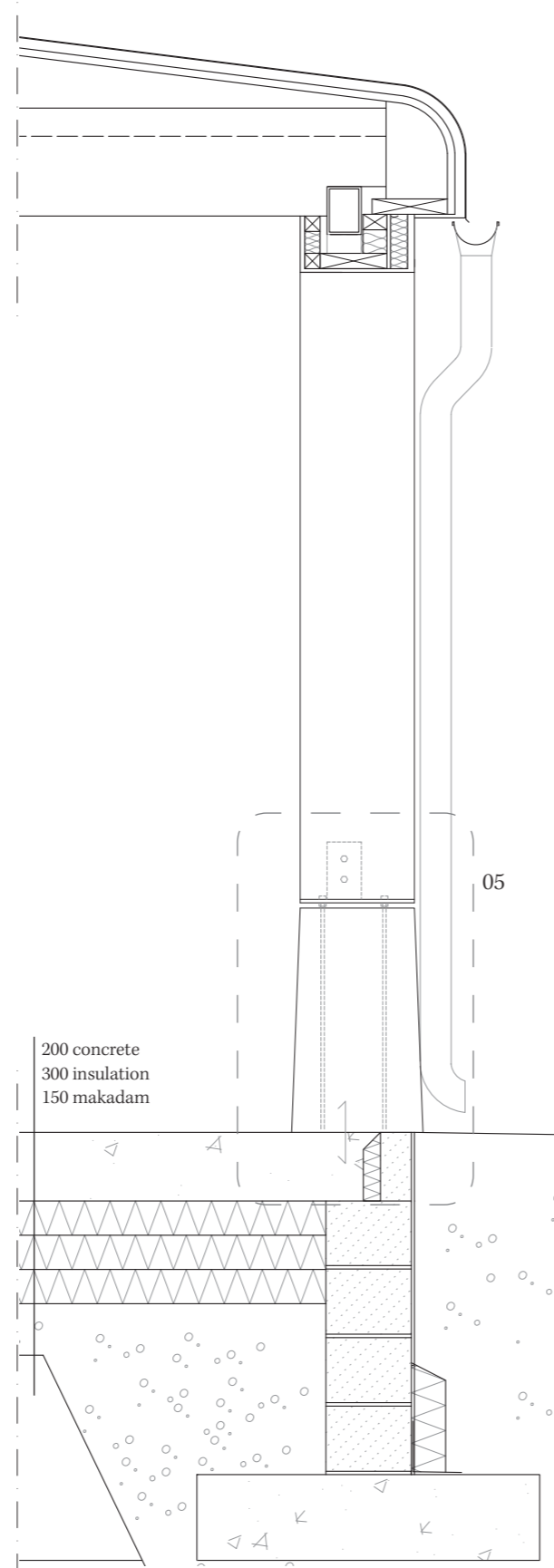

04. VERTICAL DETAIL

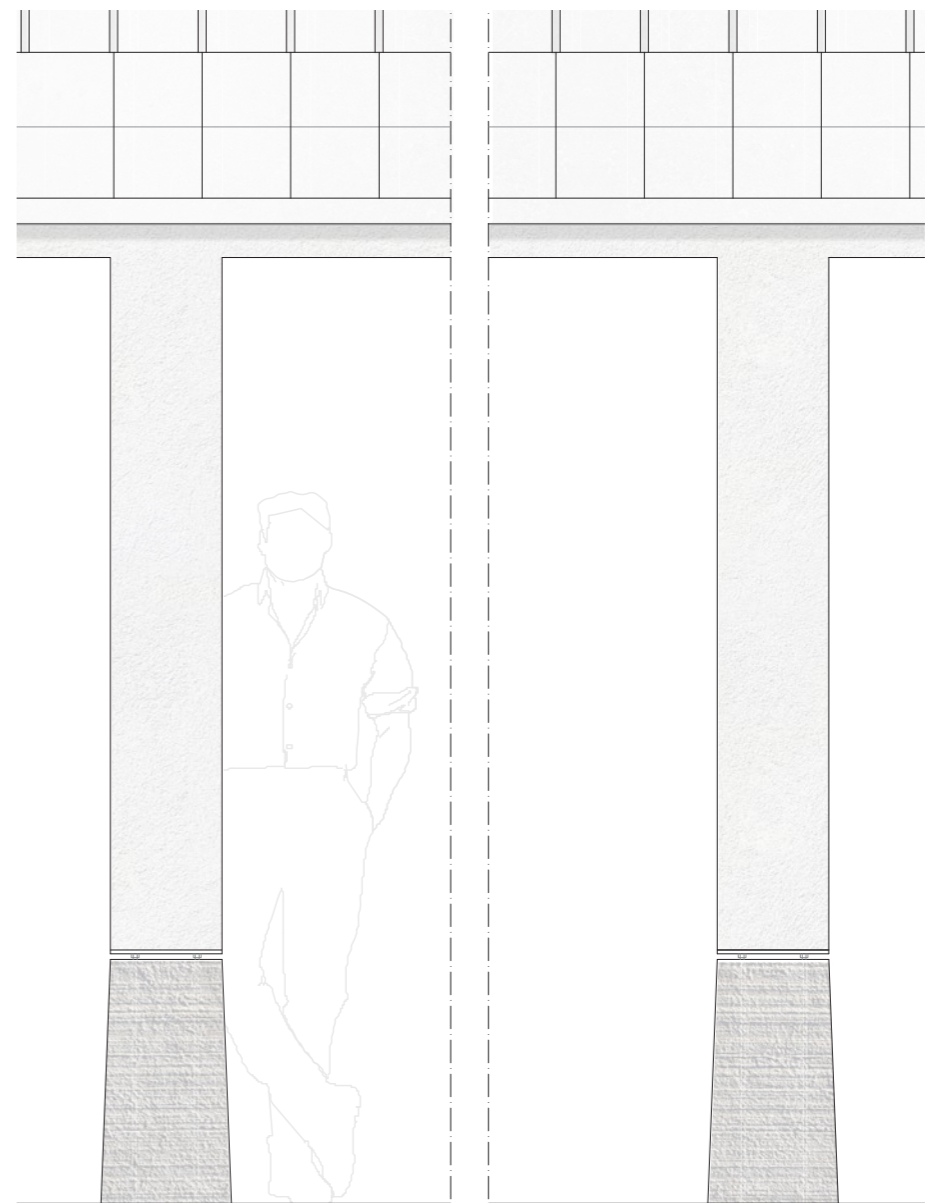
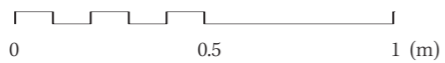

RETROFITTED ELEVATION

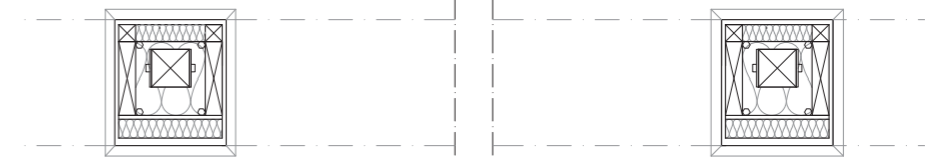

04. HORIZONTAL DETAIL

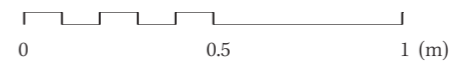

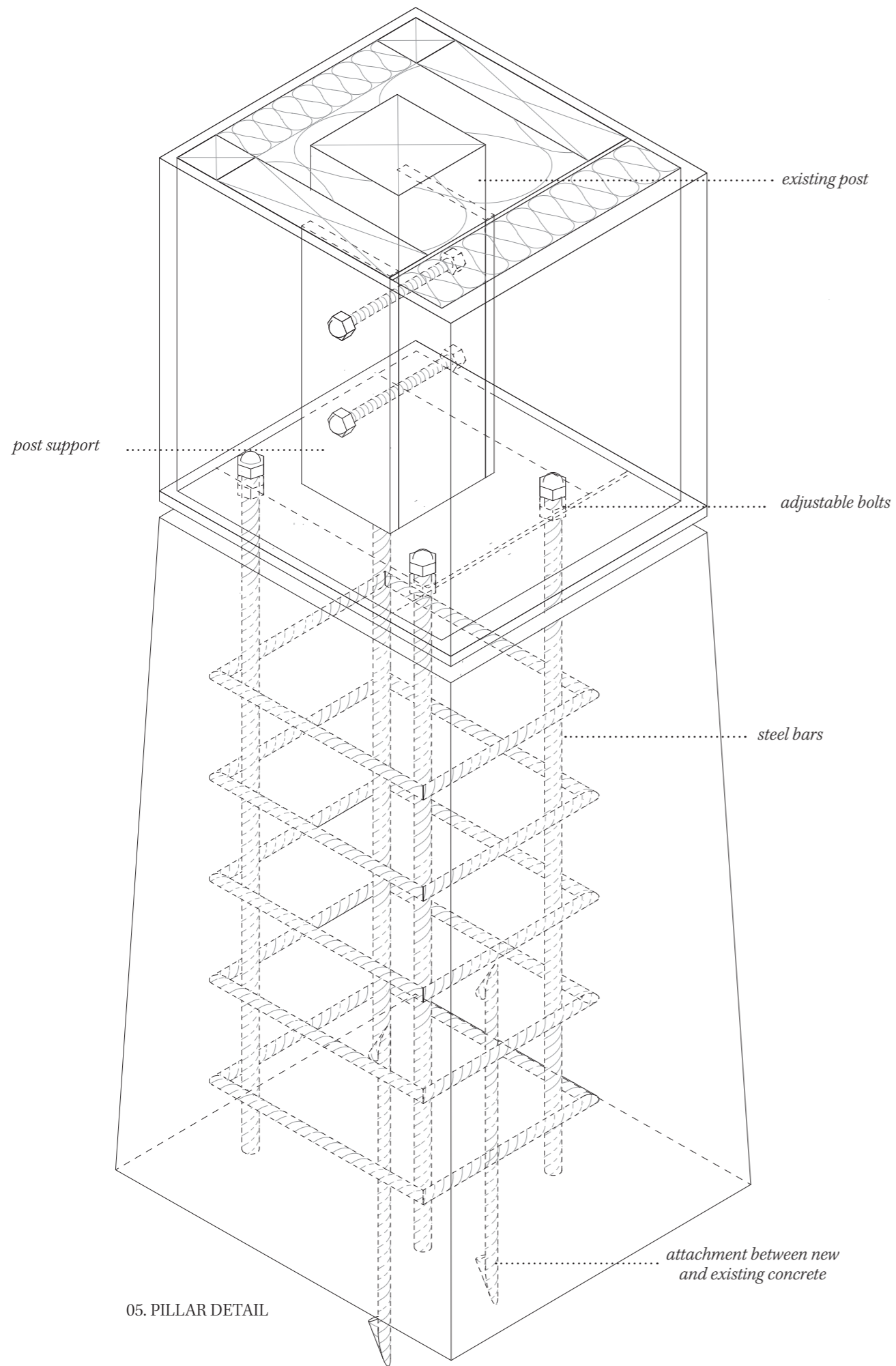

Scale 1:5

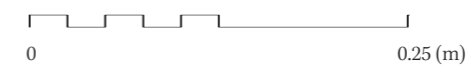
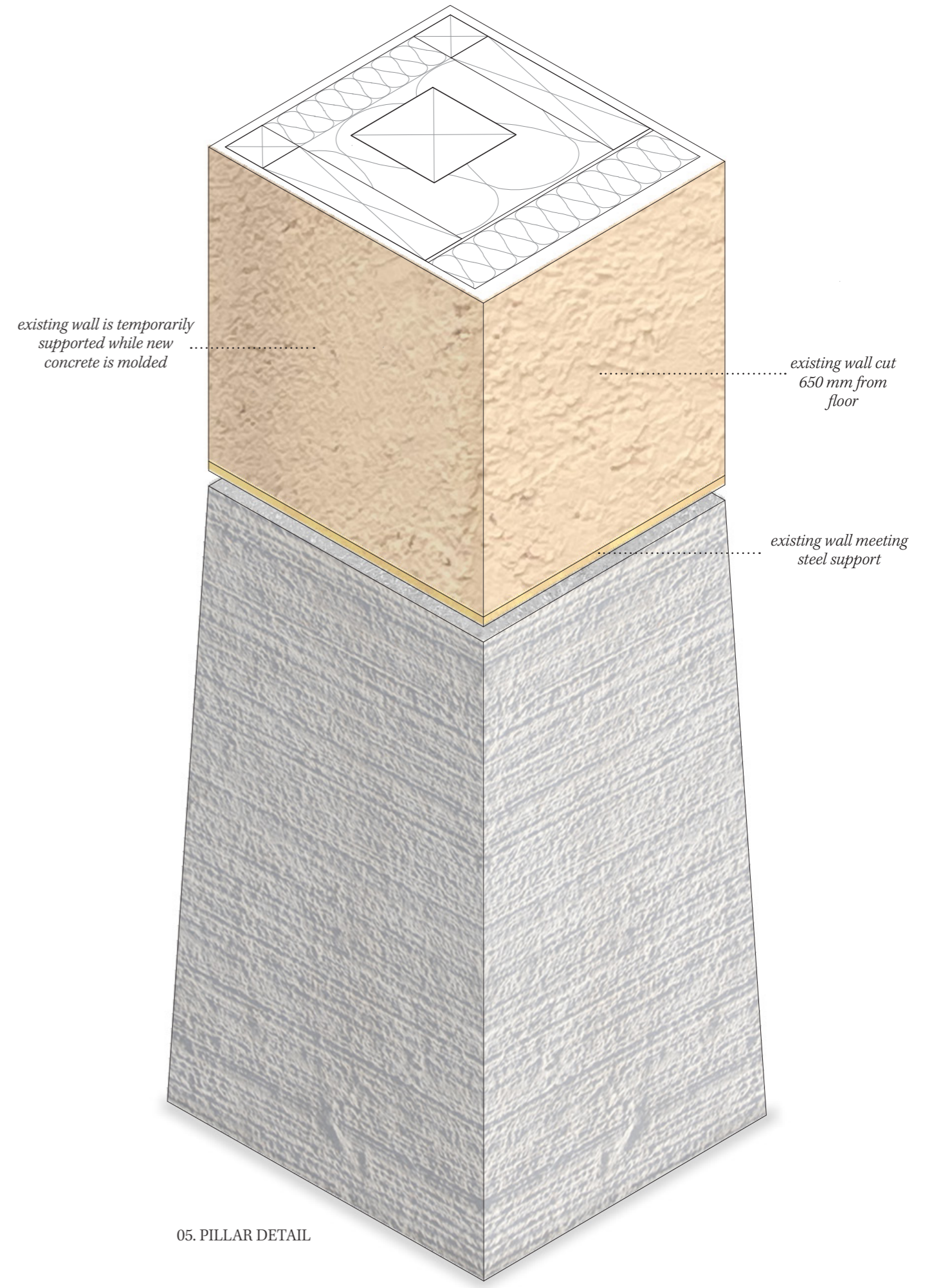

Scale 1:5



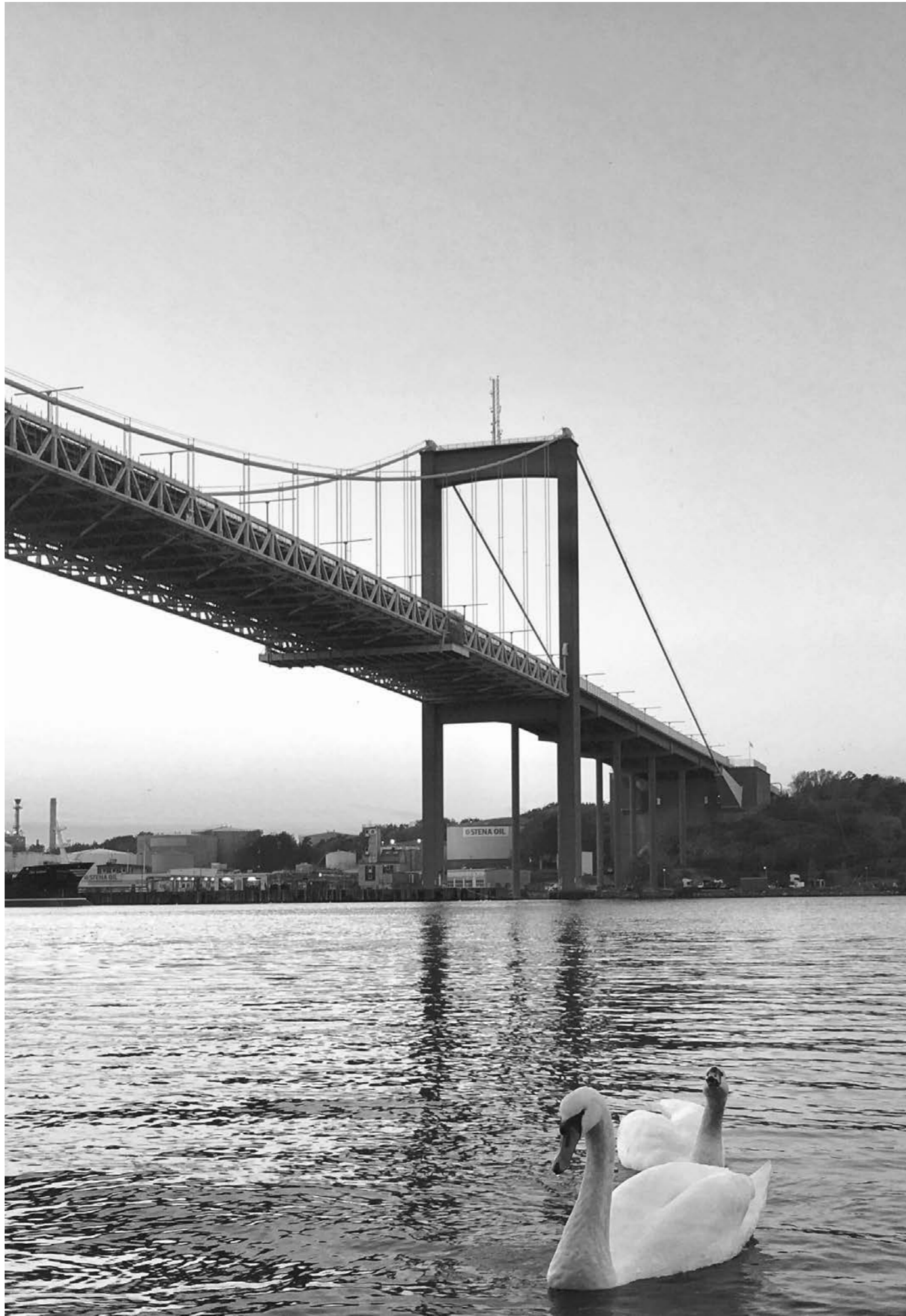

Conclusion

Discussion

The aim of this thesis has been to investigate how to preserve and adapt two buildings in a flood-prone area by utilizing various retrofitting strategies. The process started with assessing Klippans future flooding scenarios and their impact on Klippans konstcafé and Sjömagasinet. Four retrofitting strategies were presented in the theory, of which one was chosen for each building. The proposal shows a transformation from conceptual ideas into a concrete project supported by technical drawings.

The amphibious method was applied to Sjömagasinet as it is protected from major changes to its appearance and the additions can be placed below ground. The wooden building can stay out of water during flooding while it enables the existing restaurant, which is a large part of the building's identity, to remain functioning in extreme weather events.

The wet floodproofing strategy was proposed for Klippans Konstcafé as it is a concrete and brick structure that can be exposed to water.

However, the future exposure to saltwater might weather away the mortar between the bricks. Wet floodproofing leads to a new program since it involves flooding parts of the building to prevent collapse due to high pressure.

In addition to transforming the ground level into an exhibition hall, the entire building underwent a new program. It was inspired by the arts and crafts in the area, combined with the history of brewing in Klippan, resulting in a program consisting of a restaurant, brewery and exhibition hall.

In conclusion, the discussion of rising sea levels is a relevant topic for Gothenburg due to its proximity to water and increasing flooding events. The thesis contributed to the discussion with a project originating from a small-scale preservational standpoint. Based on their various conditions, two historical buildings were approached with different retrofitting strategies and adapted to sea level rise.

Reference list

Archdaily. (2023). *Le Relais Boréale Brewery / Atelier l'Abri*. <https://www.archdaily.com/995454/le-relais-boreale-brewery-atelier-labri>

Baca Architects. (n.d.). *Amphibious House*. <https://www.baca.uk.com/amphibious-house.html>

English, E.C., Chen, M., Zarins, R., Patange, P., & Wisser, J.C. (2021). *Building Resilience through Flood Risk Reduction: The Benefits of Amphibious Foundation Retrofits to Heritage Structures*, *International Journal of Architectural Heritage*, 15:7, 976-984, DOI: 10.1080/15583058.2019.1695154

FEMA. (2014). *Homeowner's Guide to Retrofitting*. https://www.fema.gov/sites/default/files/2020-08/FEMA_P-312.pdf

Fredriksbergmuseerne. (n.d.). *about cisternerne*. <https://frederiksbergmuseerne.dk/en/cisternerne/om-cisternerne/>

Göteborgs stad. (2023). *Vatten i staden*. <https://www.xn--vattenigteborg-2pb.se/SeaAndWaterways/ScenarioResult>

Göteborgs stad. (n.d.). *Klimatförändringar och extremt väder*. <https://goteborg.se/wps/portal/start/goteborg-vaxer/sa-arbetar-staden-med-stadsutveckling/miljo-och-klimat-i-stadsutvecklingen/miljo-och-klimat-i-stadsplaneringen/klimat-forandringar-och-extremt-vader>

Lindälv, E. (1977). Klippans kulturresevat och andra byggnadsminnen i Majorna. Göteborgs hembygdsförb.

Lönnroth, G. (1999). Kulturhistoriskt värdefull bebyggelse i Göteborg : ett program för bevarande. Stadsbyggnadskontoret.

Intergovernmental Panel on Climate Change (IPCC). (2022). Sea Level Rise and Implications for Low-Lying Islands, Coasts and Communities. In *The Ocean and Cryosphere in a Changing Climate: Special Report of the Intergovernmental Panel on Climate Change* (pp. 321-446). Cambridge: Cambridge University Press. doi:10.1017/9781009157964.006

SMHI. (2017). *Sammanfattning till Extremregn i nuvarande och framtida klimat*. https://www.smhi.se/polopoly_fs/1.165105!/klimatologi_47%20Sammanfattning%20till%20extremregn%20i%20nuvarande%20och%20framtida%20klimat.pdf

SMHI. (2023). *Året 2023 - Nederbörd, solsken och strålning*. https://www.smhi.se/pd/klimat/pdf_stats/year/SMHI_vov_precipitation_sunshine_23.pdf

Sjöfartsverket. (2023). *Nautisk information*. <https://www.sjofartsverket.se/sv/tjanster/lotsning/lotsomrade-goteborg/nautisk-information/>

Figures

Figure 1-2. Baca Architects. (n.d.). *Amphibious House*. Retrieved 27.10.2023 from <https://www.baca.uk.com/amphibioushouse.html>

Figure 3-4. Fredriksbergmuseerne. (n.d.). *about cisternerne*. Retrieved 14.02.2024 from <https://frederiksbergmuseerne.dk/en/cisternerne/om-cisternerne/>

Figure 5. Archdaily. (2023). *Le Relais Boréale Brewery / Atelier l'Abri*. Retrieved 27.03.2024 from <https://www.archdaily.com/995454/le-relais-boreale-brewery-atelier-labri>

Figure 6-7. Göteborgs stad. (n.d.). *Vatten i staden*. Retrieved 24.09.2023 from <https://www.xn--vattenigteborg-2pb.se/SeaAndWaterways/ScenarioResult>

Figure 8-11. Opencities planner. (n.d.) *Göteborgs stigande vattennivåer*. Retrieved 24.09.2023 from <https://eu.opencitiesplanner.bentley.com/goteborg/stigandevattennivaer>

All non-referenced images are works of the author.

Student background

Education

2023-2024
Master's program,
Architecture & Urban Design,
Chalmers University of Technology

2022-2023
Architectural Internship,
Forum Arkitekter, Gothenburg

2021-2022
Master's program,
Architecture & Urban Design,
Chalmers University of Technology

2018-2021
Bachelor's program
Chalmers University of Technology

Master program courses

30 Master's thesis in Architecture

15 Building tectonics 2

15 Master's thesis preparation

22.5 Housing inventions

3 History, theory and method 5

4.5 Architectural competitions

22.5 Architecture & urban space design

7.5 Sustainable development



