

SVILLEN | REINTERPRETING THE BOATHOUSE
CLUSTERS OF BOHUSLÄN

Anna Erixon & Julianna Smith
Chalmers School of Architecture | Department of
Architecture and Civil Engineering | Architectural
experimentation | Examinar: Daniel Norell | 2024

Thanks to
Daniel Norell
Tabita Nilsson
Peter Lindblom
Sunda Byggvaror

Svillen | Reinterpreting the boathouse clusters of Bohuslän
Anna Erixon & Julianna Smith
Chalmers School of Architecture
Department of Architecture and Civil Engineering
Master's Program of Architecture and Urban Design (MPARC)
2024

Supervisor: Daniel Norell
Examiner: Daniel Norell





SVILLEN

ABSTRACT

There is more to the rolling rocks, green patches, and flat silhouettes of the sea in the Bohuslän archipelago than meets the eye. The landscape holds sacred memories of folk who lived in symbiosis with the sea in the once-thriving fishing community. Today, the settlements of Bohuslän are considered by many inhabitants solely a summer paradise where the collectivist ideas of all-year-round communities are lost.

This thesis explores the potential of inserting contemporary architecture within the context of the Bohuslän archipelago. Through the design of a group of small buildings, based on in-depth studies of the architectural and typological features of local vernacular architecture, the thesis aims to revitalise the historical cluster typology through an architectural reinterpretation. More specifically the research focuses on 'Sjöbodar' (fishermen's boathouses). The research encompasses the sjöbod as an individual piece of traditional, vernacular architecture, including aspects of tectonics, as well as the proliferation of such buildings in larger groups or clusters. Within the cluster, a narrow, alley-like space is formed between the buildings, referred to as Svillen. Svillen is defined as the space closest to the boathouse, protected by an eave above. It was typically used as a place of practising labour, for storage, or drying nets, and was shared between the adjacent boathouses. Svillen has become of interest to the thesis as it raises questions concerning the role of the collective, i.e. the

cluster, versus the role of the individual boathouse. Lastly, the thesis has explored the social culture in the clusters through the 'Ljugarbänk' (the liar's bench) which is present in the stories about the fishing community.

The design proposal consists of a cluster that is located in the Toftenäs nature reserve in southern Bohuslän. It houses common areas and accommodates temporary overnight stays for hikers and boaters, as it lies in a natural harbour. The design evokes the memory and identity of the fishing village through a reinterpretation of the traditional construction and building typology, and becomes a contemporary addition to the harsh coastal landscape. The proposal has explored design in 3 different scales; firstly, the detail in joinery and paraphrasing of Ljugarbänken, secondly, the Sjöbod as an individual piece of architecture, and lastly the cluster, including Svillen – the relationship between the buildings themselves and the sea.

JULIANNA SMITH

MSc, Architecture and Urban Design (MPARC)
Chalmers School of Architecture, Göteborg 2022-2024

Architectural Internship
Liljewall Arkitekter, Göteborg 2021-2022

BA Honours Degree, Bachelor of Arts Architecture
Oxford School of Architecture - Oxford Brookes University,
Oxford UK 2018-2021

Contact: smithjuliannas@gmail.com
0046 7075 187 81

ANNA ERIXON

MSc, Architecture and Urban Design (MPARC)
Chalmers School of Architecture, Göteborg 2022-2024

Studio KruckerBates
TUM Department of Architecture, Munich WT 23/24

BA, Arkitektur - TKARK
Chalmers School of Architecture, Göteborg 2019-2022

Contact: anna.erixon96@gmail.com
0046 7331 898 07

CONTENT

FRAMEWORK

Terminology
Research questions
Intention
Delimitations
Method
Discourse : Awakening heritage

I. COLLECTION

Background : Topographical heritage
Background : The fishing community

II. INVESTIGATION

Area : The cluster
Mollösund
Valsängs Strand
Bovallstrand

Entity : Sjöbod(en)
Svillen
Building tradition

Detail : Ljugarbänk(en)

III. IMPLEMENTATION

Site : Toftenäs nature reserve
Architectural references
Process : Translating theory into design
Process : Design
Scheme : A traditional arrangement

Proposal : The Cluster
Proposal : The Sjöbod
Proposal : The Ljugarbänk

Discussion + Reflection

Bibliography



- SJÖBOD(EN) : Translated to boathouse in English. A timber shed for fishermen to work and keep their tools in

- DWELLING : Residential housing

- CLUSTER : An assemblage of sjöbodar or dwellings placed close together

- SVILL(EN) : The space alongside a sjöbod that is sheltered by an extended eave

- TOPOGRAPHY : The architectural landscape consisting of both dwellings and sjöbodar

- TYOLOGY : Tectonics of one single structure

- LJUGARBÄNK(EN) : Translated to the liar's bench in English. A bench placed by a sjöbod in purpose for ergonomic work or for socialising

The terminology will work as a tool for defining certain elements within the Bohuslän archipelago architecture. It also translates terminology that in Swedish has a different definition than in English.



How can contemporary architecture evoke the cultural and architectural heritage of the Bohuslän fishing villages?

What characterises the vernacular 'Sjöbod' cluster typology, and what can architecture learn from it?

INTENTION

This thesis intends to explore different aspects of implementing contemporary architecture into the historical context of the Bohuslän archipelago. The aim is not to find a specific answer to the thesis questions, but rather contribute to the discussion of the relationship between contemporary architecture and built heritage values. The focus has been oriented to study historical, local building topography, typology and building traditions.

DELIMITATIONS

The design does not seek to replicate or mimic existing architecture in its historical form.

This thesis does not account for shoreline regulations or financial aspects, nor does it consider the impracticality of construction within a nature reserve, given the project's hypothetical nature.

The site is only accessible by boat or hiking in a coastal landscape for 2-3 kilometres. This means that people with certain functional variations cannot make it to the site. This project is assumed as an exception to the accessibility requirements.

If the project were to be realised there is a need for in-depth investigations of self-sufficiency to investigate how these ideas would work in practice.

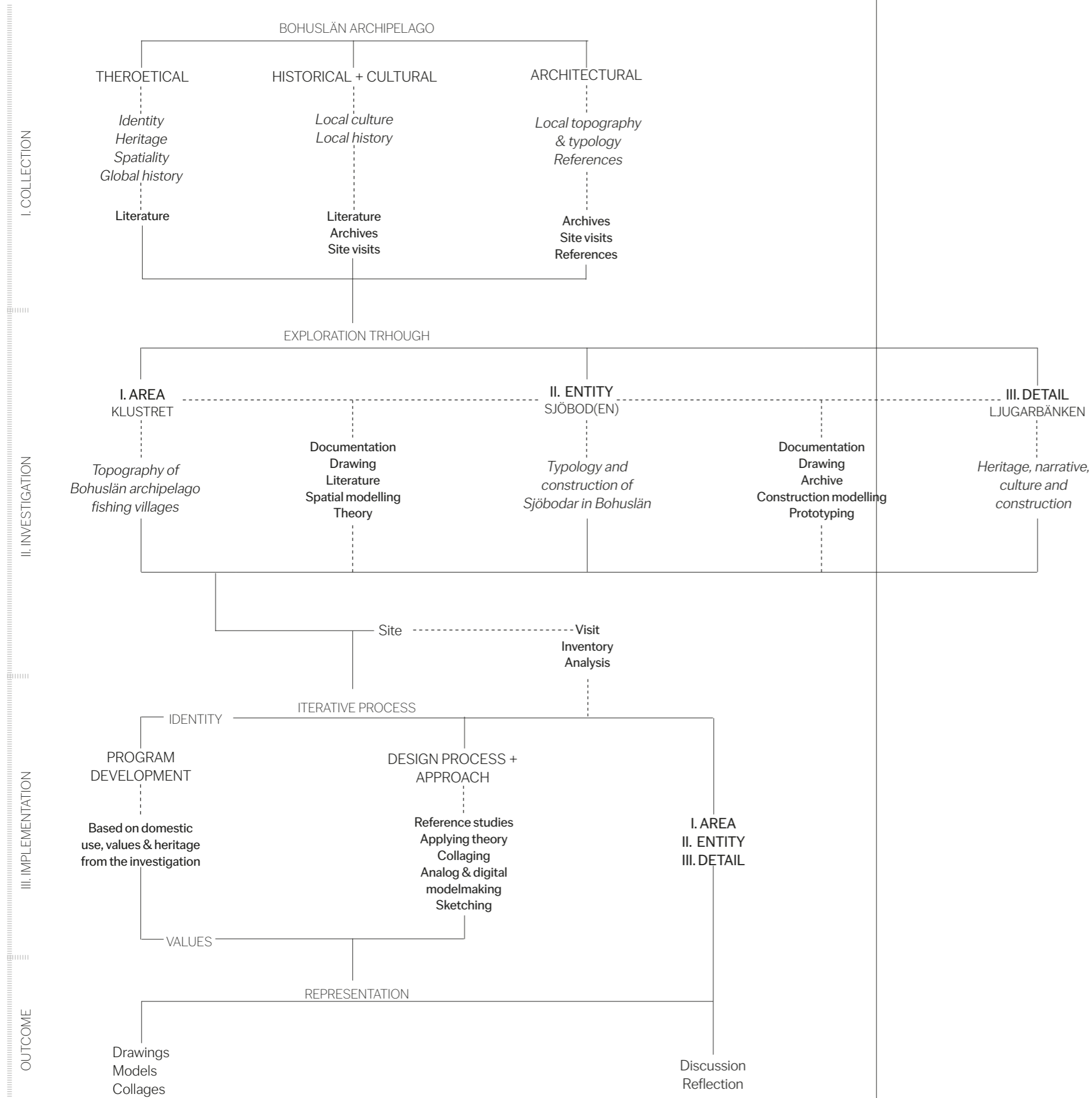

METHOD

The thesis has been conducted through historical literature, close studies and analysis of several boathouse clusters located on the coastline of Bohuslän. Additionally, the research includes theories regarding values, identity and collective ideas of living, within the field of architecture. The work culminates in a design that confers high value on the local, historical context whilst experiments with translations, imitations and reinterpretations of the historical context and architecture.

The research method is based on `design through research` as well as `research by design` and is divided into 3 phases: Collection, Investigation and Implementation, to be able to answer the thesis questions relating to the subject of this paper.

COLLECTION

The first phase, collection, focuses on collecting as much data as possible regarding the context, history and theory related to the discourse, to develop a clear understanding and standpoint within the subject.

INVESTIGATION

The investigative phase is directed towards studying the existing context more in-depth, which includes explorations of three existing cluster typology of sjöbodar in Bohuslän: Bovallstrand, Mollösund, and Valsång Strand.

IMPLEMENTATION

The Implementation phase consists of several design explorations, testing out architectural principles and methodologies presented in the theory and applying them to the context of our thesis work. The design proposal presented is supported by theories and methodologies that reinforce the design choices based on the research conducted in the initial phases and open up for discussion connected to the discourse.



'spirit of a place,' as a fundamental concept for capturing the intangible essence of a historical site. The genius loci of any physical space is rooted in its distinct characteristics, its memory, and the ambience it holds.

"The notion, or phenomena, of a place is made up of the things and further underlying phenomena found in relation to it. People, animals, flowers, trees and forests, of stone, earth, wood and water, towns, of streets and houses, doors, windows and furniture, are multiple layers that in assemblance can be seen as a concrete phenomenon of our everyday life-world. [...] Together these things determine an 'environmental character', which is the essence of a place."

Norberg-Schulz p.6

This highlights the significance of acknowledging and valuing a space's identity, history, and intrinsic characteristics when conceptualising modern architectural designs. According to Norberg-Schulz (1979), this approach to design can yield spaces that are more profound, comfortable, and conducive to human well-being.

Taking inspiration from existing topographies is not new; artists and architects have been replicating and imitating designs for centuries (Plevoets & Van Cleempoel, 2019). But the historical vernacular fishing villages of Bohuslän did not take shape overnight, nor did architects and designers plan them. Instead, they evolved gradually over an extended period, influenced by the community that inhabited them (Werne & Östnäs 1982). This is an important acknowledgement to consider when exploring reinterpretations of such a historical reference.

AWAKENING HERITAGE

In contemporary architectural practice, it is not guaranteed that buildings will be anchored to their local context, seamlessly blending in with their surroundings. Architects and builders often face tight budgets and deadlines, which can lead to a focus on practical aspects rather than the intangible qualities of a place. Occasionally, tangible values are prioritised over intangible ones, culminating in buildings that feel out of sync with their environment and disrupt the natural landscape. One contributing factor to this is the prevalence of modern building techniques, updated standards and evolving patterns of use (Pettersson, 2013).

Narrowing down the discourse of this thesis it orientates through Bohuslän by using the book "Bygge i Bohuslän" by Finns Werne and Sara Östnäs (1982). The discussion regarding the importance of incorporating local heritage and context into contemporary design is something this thesis intends to emphasise whilst questioning what modern architects can learn from the existing, vernacular architecture in question. Furthermore, the thesis contributes to the discussion of introducing contemporary architecture in, or based on, a historical context.

The characteristics of a physical place, emphasised by Norberg-Schulz (1979), can embody their spirit and identity. He introduced the term 'genius loci, which translates to the

I. COLLECTION

Götaland. These lumbermen would construct the house, mark each log, deconstruct it, and then ship it to Bohuslän, where fishermen would reassemble it (Werne & Östnäs 1983). In the early 19th century, the prevalent architectural style was the "enkelstuga" (single house) in coastal settlements. However, a new typology emerged shortly after: the "dubbelhuset" (double house), which became more common. The double house typically featured two stories, enabling house owners to rent out the upper part to tourists and relatives (Werne & Östnäs, 1983). During the 20th century, other construction techniques, such as timber framing became more economical and time-efficient for the local contractors to build. Nevertheless, several houses are showcasing pure gingerbread work from this era. The finish of the dwellings and boathouses has evolved since the 17th century. Originally, the dwellings were painted in red (falu rödfärg) and the boathouses were of untreated wood; today the dwellings are normally painted with light oil paint in palettes of white and pastels whilst the boathouse's finish varies from red, ochra or untreated wood.

In the first half of the 20th century, modern amenities like bathrooms and central heating became more common in Bohuslän, leading to more diverse and larger houses with varying aesthetics. Nonetheless, the later architecture (in the later half of the 20th century) retained the fundamental components of a timber structure on a stone foundation. This type of construction is still, today, the most careful way to build in the Bohuslän archipelago to preserve the over 900 million years of ancient bedrock (Pettersson, 2013). The irregular landscape of the rock has forced the coastal settlements to adapt their architecture in a site-specific way.

TOPOGRAPHICAL HERITAGE

In Bohusläns coastal architectural context, there is a recurrent configuration in determent order from the seashore: the boat, the pier, the boathouses, the main road and the dwellings. The entities have created the characteristic architectural clustering. Where rational building techniques and social adaptation to the fishing community have prevailed, it has taken on a purposeful and, in its way, regular form, as far as this has been possible in the often rugged terrain. Inhabitants prioritised having a connection to the ocean, with a common rule dictating that at least one top-floor window should offer a view of the sea (Werne & Östnäs, 1983).

When finding oneself within a Bohuslän coastal cluster that can appear in either Mollösund, Hunnebostrand or Smögen, there is a sense of security and care for the domestic space. The space between the structures is inviting, yet it can remind one of trespassing on a private area. This feeling raises the question of what belongs to whom and what is shared space.

Most of Bohuslän's architecture is constructed using timber with a stone foundation. The three primary communities within Bohuslän—farmers, fishermen, and masons—cooperated to build this architectural heritage. In the 1700s, the region's forests were significantly depleted to supply wood for the Danish navy's shipbuilding. Until 1870, Bohuslän's residents would often order a house frame from lumbermen in Västra

"The character of the place is to a high extent determined by how this standing and rising is concretized. This also holds true for entire settlements such as towns. When a town pleases us because of its distinct character it is usually because a majority of its buildings are related to the earth and the sky in the same way; they seem to express a common form of life, a common way of being on the earth. Thus they constitute a genius loci which allows for human identification."

Norberg-Schulz pp. 63&65



"Husen i sig (mestadels vita) gjorde inget större intryck, det var mest hur de låg, en fantastisk kust (också för vykortsfabrikanterna) och ett ljus som bländade."

Hansson (2000) p. 15



*“Allt sprödare blev den grova segelduken
och en dag var den borta.
En gul container,
minnena — på egen hand.
Att snart inte finnas mer.”*

Hansson (2000) p. 15

Photograph of fishermen after an expedition in Tromsø on the ship Kuttern.
Fr left: two front row: unknown, fr left 2:nd row: unknown, Karl A Ögård,
Albert Andersson, "Bölja" Nilsson, Hugo Johansson (called "Tappe-dor"),
unknown, fr left 3:rd row, Sven Olsson, unknown.
Unknown photographer, Iceland, 1917

13

THE FISHING COMMUNITY

The Bohuslän fishing community, with its roots tracing back to the 1600s, has been a pivotal force in shaping the cultural and architectural landscape of Sweden's west coast. This unique blend of farmers, maisoners, and fishermen, though deeply connected to their respective communities, drove economic prosperity during specific periods. Particularly in periods from 1550 to 1906, when herring stocks in Nordic waters thrived. The enduring presence of sturdy timber structures and the distinctive local topography are a testament to this historical legacy. (Werne & Östnäs 1982). This tightly-knit community, comprising men, women, and children, revolved around the rhythms of fishing. Women managed households and played crucial roles in fish processing whilst the men were at sea (Bohusläns Museum, 2023). For the inhabitants to survive in the coastal climate all year round, they were reliant on each other as much as the goods from the sea.

Werne (1982) describes these communities as a group where everyone was equal and no one wanted to be pointed out as better off or unique within the community. Everyone fought the same fight for survival and prosperity. The descriptions of this collective way of living contrast with current ideals of individualism and consumerism. Being a fisherman meant being a member of a collective, the commonality had not only to do with architecture but also values, upbringing, clothing, eating habits etc. The uniform settlement is a result of the common togetherness of the villages.

The architectural topography on the coast was vital for the community to keep close contact - there was always someone close by to ask for assistance or to socialise with. However, the 1960s brought a significant transformation within the industry, ultimately affecting the community. Modern trawlers, while modernising the fishing industry, led to overfishing and environmental degradation of the seafloor. Consequently, fishing, once the primary source of livelihood, lost its appeal for many, triggering emigration and commuting to nearby towns for work. This resulted in a decline in the coastal community population as well as an increased dependence on the larger society's institutions (Werne & Östnäs 1982).

In the 1960s and 70s, an influx of summer guests from neighbouring larger towns, such as Gothenburg began investing in Bohuslän archipelago properties for seasonal use. This phenomenon inflated property prices and curtailed the ability of residents to secure permanent homes. Presently, most archipelago houses are occupied seasonally, denying permanent residents the opportunity to acquire property. As a result, currently, Sotenäs municipality has the highest proportion of part-time residential housing within a village topography in Sweden (Gustafsson, 2022). Today, tourism serves as one of the municipalities' primary economic lifelines (Svedberg, 2013). This shift has profoundly impacted the once-thriving local communities, which were once the heart and soul of the region's social and economic life (Werne & Östnäs 1982).

II. INVESTIGATION



AREA : THE CLUSTER

AN ASSEMBLAGE OF SJÖBODAR OR DWELLINGS PLACED CLOSED TOGETHER

The coastal village typology of Bohuslän is a reflection of the strong community. The buildings are positioned so close to each other that one could open their window and reach out to knock on their neighbour's. This way of building originates from relieving the community to endure the harsh weather coming from the sea. The narrow alleys and trails protected both the inhabitants and their houses from the heavy winds and rainfall occurring on the west coast. Being located close to the seashore and facilitating outdoor activity, the architecture was adapted to the life of the fishermen. The space between the Sjöbodars and dwellings was used for social activities but also functional ones. The functional activities were related to the fishing occupation, such as drying nets, storing equipment and washing oneself up after a day at sea. Today, a majority of the boathouses in Bohuslän are private properties, however, the plot does not extend beyond the exterior wall of the boathouse; leaving the space in between the structures ownerless (Werne & Östnäs, 1983).

During the 1920-1940s modern city planning was proposed to match the new guidelines for fire safety, electricity and plumbing systems. These proposals were highly contradictory to the existing typology as they were not as responsive to the local climate, landscape and existing community. They were highly related to the

existing urban landscape in the nearer larger cities, such as Gothenburg (Werne & Östnäs, 1983). The cluster structure of the fishing village topography can be seen as a group form; a purposeful grouping of buildings with reasons to be together (Maki & Ohtaka, 1964). They have evolved, unintentionally designed, over a longer period. Therefore, they hold a sequential value rather than collective forms that have been built all at once (Maki & Ohtaka, 1964). The lack of intentional design contributes to the challenge faced by architects and planners, in creating meaningful collective forms today. This becomes clear when comparing the clusters to the areas built during the 20th century in Bohuslän.

The need for contact within the fishing community relates to its topography. Jan Gehl's theory of see-and-hear contact (2011) is something that highly relates to the social conditions in the Bohuslän archipelago. The physical closeness between the dwellings makes the neighbourhood constantly observant of each other's children and premises - creating a feeling of safety and trust among the inhabitants; both in modern times as well as during the 19th hundreds. Gehl's theories are explored on a larger urban scale, however, they apply to the Bohuslän archipelago architecture as well as the fishing community's, once strong social bonds. It exemplifies the correlation between a strong community and public space as well as questions the ideas of collective and individual rooms.

For a deeper understanding of cluster typology as an architectural phenomenon, the thesis explores 3 different boathouse clusters on the coastline of Bohuslän. The closer studies reveal the systems within the cluster topography as well as the vernacular construction of the individual boathouses.

MOLLÖSUND

Significant for the cluster in Mollösund is the absence of a grid. The boathouses are all positioned with their gable towards the sea. The pathways are narrow and there is no hierarchy between them. The border between land and water is blurred by wooden constructed piers and porches. The typology is wooden houses in colours of red, yellow, white and untreated wood that have been restored and built during different periods, initiated during the 18th century (Werne & Östnäs, 1983).

The variation of angles and positioning of the structures within the cluster results in an irregular group form. The triangular space that occurs between two off-grid-placed boathouses creates a place of protection and shelter; almost an exterior space that acts like an interior due to it being limited by surrounding walls. The cluster of boathouses lies close to the dwellings with only pedestrian paths in between; exaggerating the feeling of intriguing private property, nevertheless inviting social outdoor activity.

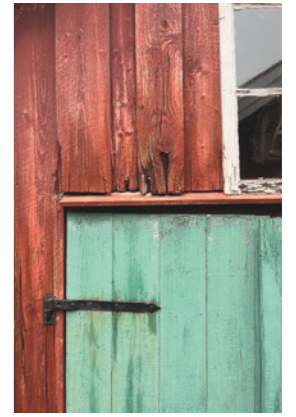

Valsängs Strand

Bovallstrand



VALSÄNGS STRAND

The historical boathouses of Valsängs Strand hold high cultural value and have been protected by preservation laws since the 1990s. There were originally 7 structures that were all built during the 18th century but 2 of them were demolished during the 1930s (Bebyggelseregistret, 2006). Valsängs Strand has no structure or grid and calling it a cluster is perhaps an exaggeration due to the scatteredness of structures. However, since the boathouses have been abandoned and later prevented from restoration or change, they embody the traditional type of boathouse aesthetic and tectonics, showcasing their untreated finish.

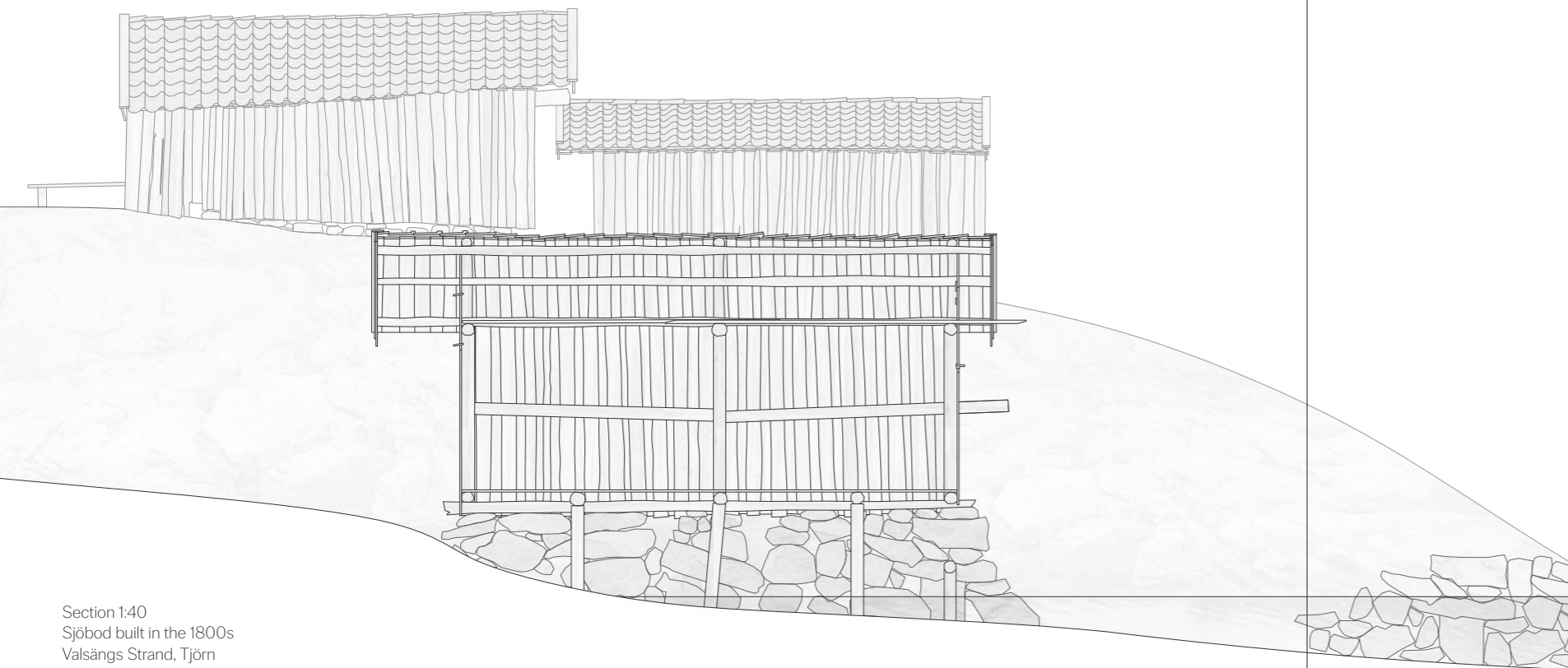
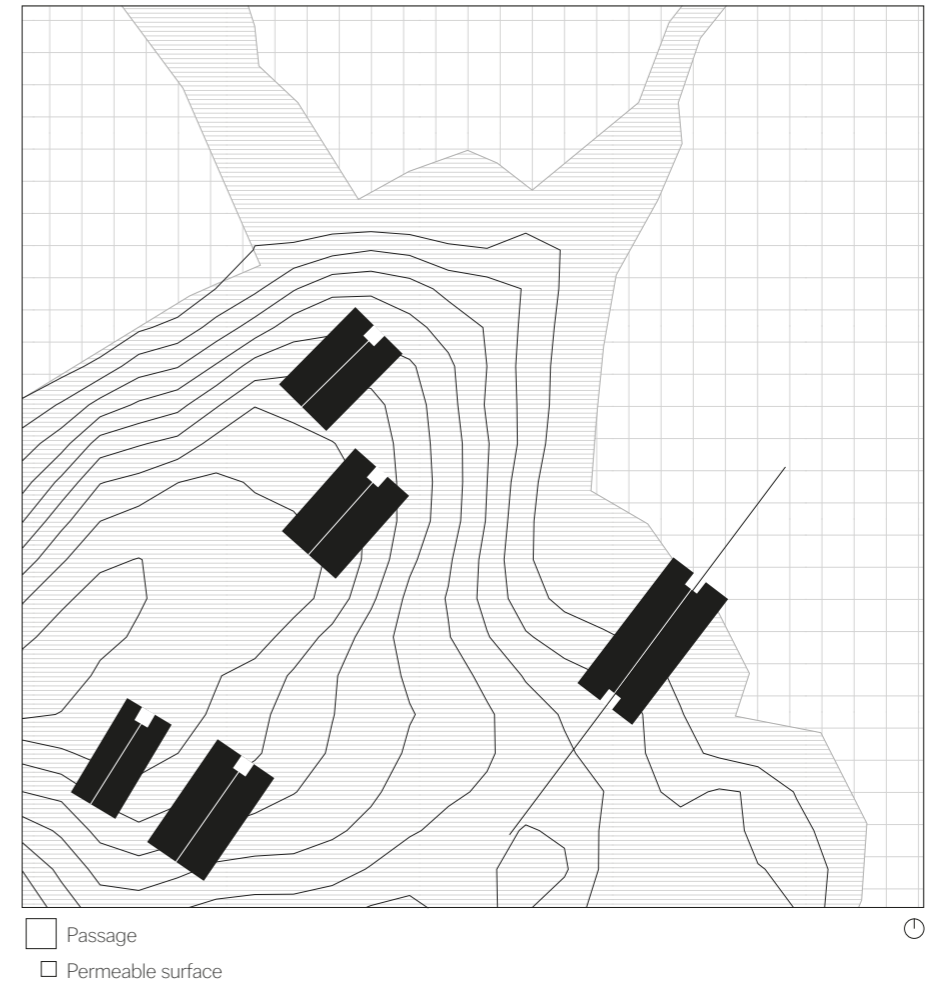

Section 1:40
Sjööbod built in the 1800s
Valsängs Strand, Tjörn

BOVALLSTRAND

The cluster was first built in the 1830s and according to Lantmäteriet, the boathouses were historically owned by the fishing community for public use (2023). Today, they are owned by private persons who own dwellings in the area. The cluster consists of wooden structures that are clad with untreated or painted in red. The cluster holds a more structural grid with gables facing main pathways that extend onto the sea by piers.

This type of cluster structure is less inviting for social interaction as it offers less public room than the clusters in Mollösund and Valsängs Strand. However, it holds optimised qualities for the fishing profession, due to the broader paths and direct connection to the boat pier.

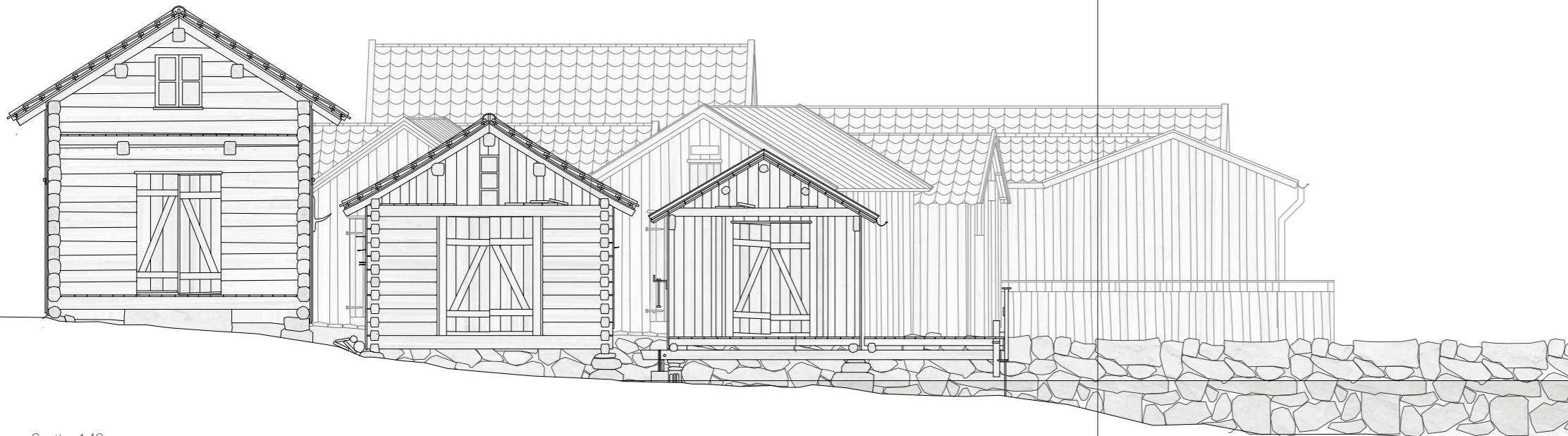
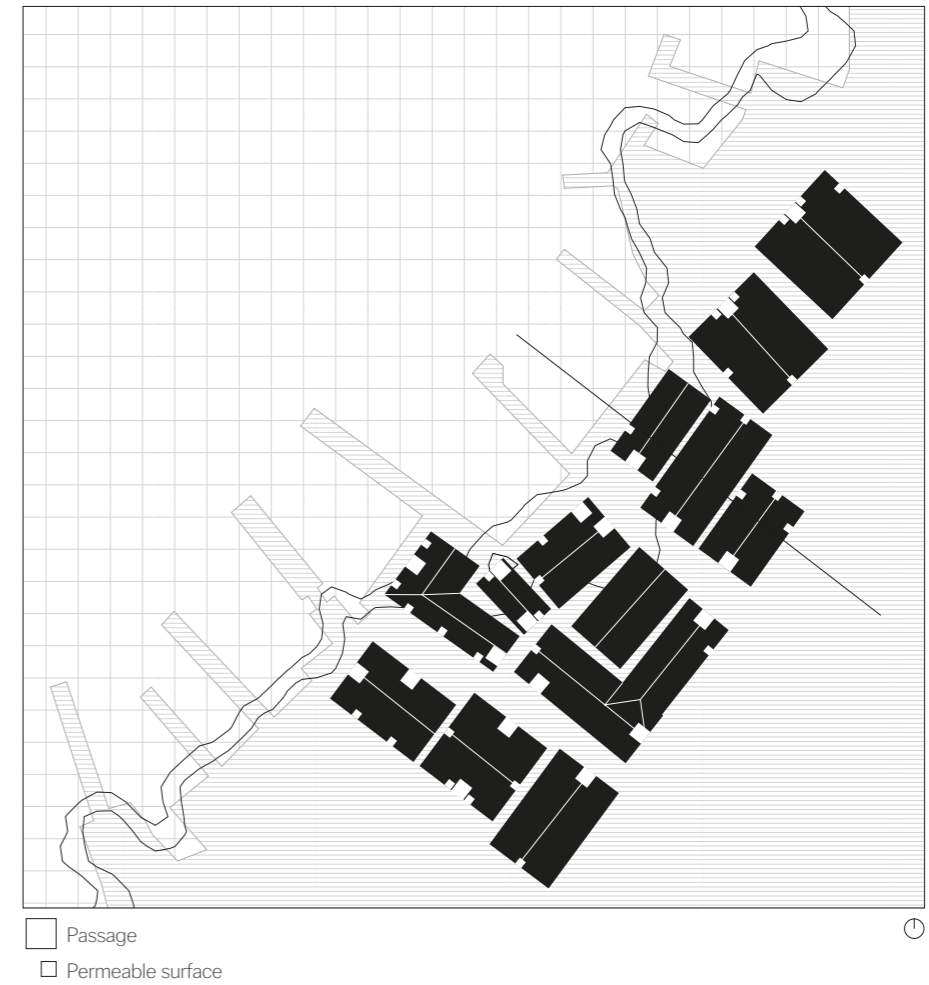

Section 1:40
Sjödodar built in the 1900s
Bovallstrand, Sotenäs

1:500
Cluster in Bovallstrand



ENTITY : THE SJÖBOD(EN)

A TIMBER SHED FOR FISHERMEN TO WORK AND KEEP THEIR TOOLS IN

The local historic architecture of Bohuslän is a vernacular building typology, built with local materials and techniques that were available at the time. Dwellings have had a variety of solutions, designs and building structures over time, from being logged to using timber framing and stone foundations. A typology that has remained within the villages is the boathouses. These were the houses where the fishermen prepared and kept all their fishing equipment, located right by the seashore, easily accessible by boat. The Sjöbodar were rarely built independently, hence it was always part of a cluster.

The Sjöbod is of interest to the thesis due to its role as a landmark for Bohuslän and its embodiment of the intangible values and heritage of the fishing community. Its vernacular and traditional characteristics and tectonics are sustainable in terms of materiality and long-lasting sturdiness. Furthermore, the boat houses are built with such a foundation that they do not leave traces of a manipulated environment; leaving the ancient Bohuslän bedrock untouched. The stilts are often constructed with irregular rocks, timber or left-over building blocks.

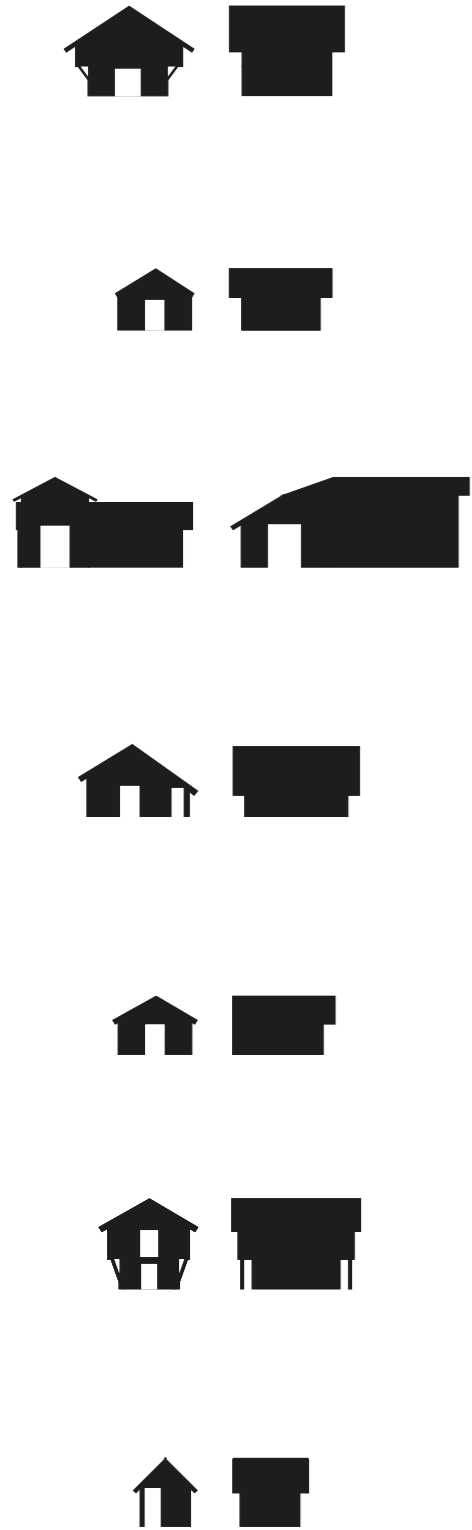

SVILLEN

THE SPACE ALONGSIDE A SJÖBOD THAT IS SHELTERED BY AN EXTENDED EAVE

Typically Svillen is only defined by the space on the gable of a boathouse that works as an outdoor porch in front of the entrance. However, the thesis refers to Svillen as all of the space closest to the boathouse that is protected by an eave above. Svillen has become of interest to the thesis, mainly because it raises questions concerning the role of the collective, i.e. the cluster, versus the role of the individual boathouse. It challenges what space within the cluster is considered shared/ownerless and what is private.

Additionally, Gehl's theory about the 3 types of activities (2011) becomes relevant when exploring Svillen. Them being: necessary, optional and social activities; all occurring within a public urban environment, dependent on the surrounding conditions of comfort. The fishermen had mandatory labour to perform in outdoor conditions all year round to survive. Svillen is a result of making the necessary activities as comfortable as possible in the coastal environment. The conditions within Svillen are a result of creating necessary activities more comfortable. The space is equipped to make the bare minimum of outdoor working space: somewhere to sit (ljugarbänken), immediacy to all the required tools and shelter. By creating this comfort Svillen turns into a place for optional activities (Gehl, 2011); including social interaction and a place to be at peace.





There is a rich tradition of wooden construction in Sweden, where builders utilized building materials available in the local environment. Due to the inherent qualities of wood, these structures are resilient against harsh weather conditions and can endure for centuries. As a result, Sweden has approximately 100 known buildings dating back from before 1527. The wood building is a fundamental aspect of Swedish cultural heritage, contributing distinctive character to the surrounding landscape (Aronsson, et. al., 2001).

TIMBER JOINERY TECHNIQUE

In this master's thesis, we have opted to emphasize a specific traditional form of wood construction, namely the timber joinery construction, which, mentioned before, is a construction type that is frequently found in the Bohuslän archipelago.

The timber joinery technique was, up until the 19th century, one of the most common building construction methods in rural areas. The Timbered walls create a good indoor climate and facilitate effective moisture diffusion throughout the house. It is advisable to use strong and coarse heartwood pine with natural dimensions for timbering, as it exhibits high resistance to decay. However, spruce works well too.

The coniferous tree possesses the characteristic of being relatively soft, which makes it easy to work with (Håkansson, 2014).

CORNER JOINTS

There are numerous variations of different knot types that have developed over time. In certain regions, there are local adaptations of the same knot type, and the age of corner joints can be determined by the shape of the wood knot. The knot heads have evolved from a round shape to a hexagonal shape and have later transitioned into dovetail joints (slätknutar) without protruding knot heads. The configuration of the joint can signify the intended purpose of the building. More sophisticated joint types with a threshold are employed to enhance thermal insulation capability (Håkansson, 2014).

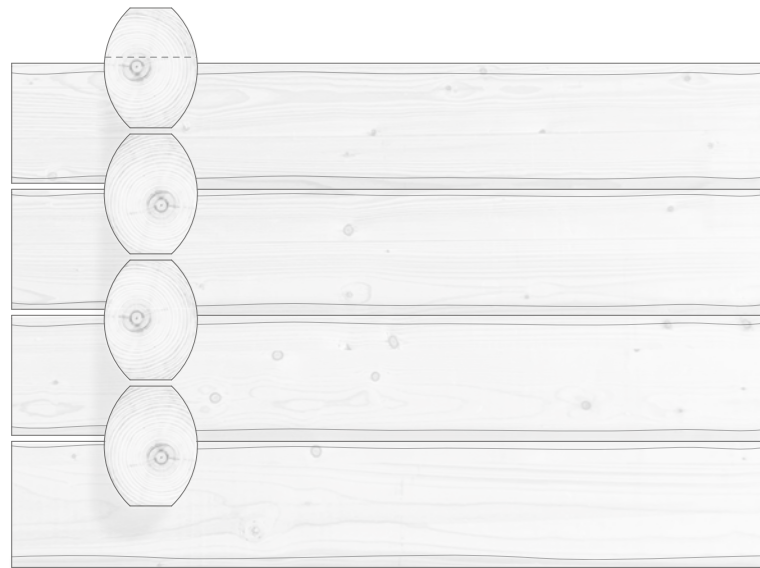

RÄNNKNUT
SINGLE-NOTCH KNOT

“Rännknut” corner joint is the oldest and plainest known type of knot. It is commonly used even today, but on simpler types of buildings that do not have as high requirements for appearance, insulation, and strength. It has a notch on the top of the log with a depth of half the log diameter (Håkansson, 2014).

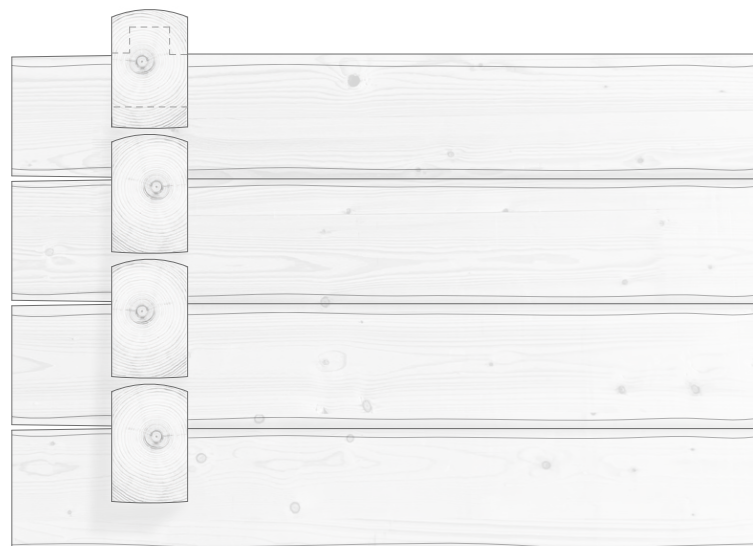

RAK DUBBELSKÅRIG KNUT
STRAIGHT DOUBLE-NOTCH KNOT

The straight double-notched joints were very common until the early 1900s and were relatively easy to manufacture. These joints are typically used on squared timber. If made carefully, they can become very tight (Håkansson, 2014).

Straight double-notch knot without threshold:
Easy to construct but not suitable for structures with elevated thermal insulation requirements.

Straight double-notch knot with threshold:
A threshold is carved in the middle of the notch, making the joint tighter and more resistant to twisting (Håkansson, 2014).



LAXKNUT
DOVETAIL JOINT

“Laxknut” is a type of smooth knot that originated in the 19th century when people started covering log houses with vertical paneling. It was common until the early 20th century. Knot heads that do not have a protruding head were considered more challenging to build. The heads were stacked on top of each other and locked with sloping surfaces. Sometimes, a wooden peg was also hammered into the middle of the knot (Håkansson, 2014).



DETAIL : LJUGARBÄNK(EN)

A BENCH PAVED BY A SJÖBOD IN PURPOSE FOR ERGONOMIC WORK OR FOR SOCIALISING AMONG THE FISHERMEN

The narrative of Ljugarbänken the 'liar's bench' is present in the stories from Bohuslän when reading about the historical cultural usage of the domestic space. Ljugarbänken is a bench, often located on the wharf, sheltered against a Sjöbod or in Svillen. The bench is a common space where fishermen would socialise, tell tales and half-truth stories to each other.

The liar's bench is of interest to the thesis due to it being representative of the usage and social culture within the clusters. It combines the idea of labour and leisure regarding the fishing occupation and way of living.

The narrative of Ljugarbänken is to be incorporated into the master thesis in the shape of a 1:1 furniture based on the purpose and usage of Ljugarbänken.

III. IMPLEMENTATION

TOFTENÄS NATURE RESERVE

The site at Toftenäs Nature Reserve lies in the northwest part of Tjörn Municipality and is part of the undulating mountain landscape, characteristic of the Bohuslän archipelago. The area has a long history of human habitation dating back to the Bronze Age, as well as having one of the oldest landings from the sea documented at Toftenässtrand from 1594 (Länsstyrelsen 2024). The landscape shows traces of farming labour; such as traditional stone walls separating the pasturelands.

Toftenäs has a high biodiversity with a mix of both vegetation and wildlife that are common in Bohuslän. Alongside rocky slopes grows heather and juniper bushes. Fields are integrated between the rocky terrain, where sheep, horses and cows are grazing in the still active agricultural landscape. Stone types that are common in the area are gneiss and granite (Tjörns municipality, 2024). The temperature varies between +15 - +25 °C during summer and +3 - -3°C during winter. Precipitation varies from 40 - 50mm in January to 70 - 80mm in July. Snowfalls are moderate and occasionally during the winter season (SMHI, 2024).

The site was selected based on its geographical placement within Bohuslän, characterised by typological conditions resembling those examined in the previous investigative phase. Situated within a natural harbour and is close to

civilization, as well as being integrated close to hiking trails such as Toftenäs Vandringsled (Tjörns municipality, 2024), making it an accessible site for both hikers and boaters. The intriguing mix of fields and rocky coastal environment creates moments of quietness and shelter as well as opens up towards the sea. The landscape and its qualities have contributed to the choice of material and outcome for the design.



Toftenäs nature reserve

Skärhamn

Site

Toftenäs hiking trail



Toftenäs





The pieces of architecture educate the visitors of the memory of the minors working in the harsh canyon conditions. Furthermore, it contributes to the contemporary way of living and visiting Sauda, by hosting a café.

CALIFORNIA SEA RANCH

Al Boeke, Joseph Esherick, Donlyn Lyndon, Charles Moore, Richard Whitaker: California, 1964

The wooden facades and uniform shapes of the Sea Ranch exemplify contemporary cluster architecture. A significant distinction between the cluster typology of Bohuslän and the California Sea Ranch lies in the treatment of volumes: while Bohuslän features individual volumes, the Sea Ranch opts for a single, larger volume spatially divided into distinct areas. Additionally, the Sea Ranch embodies the concept of coastal architecture designed to mitigate strong winds, thereby facilitating outdoor activities.

HÖGHULT

Fabel Arkitektur: Karlsborg, Sweden 2020

The timber lodge in Höghult has played a role in the thesis serving as a focal point for delving into contemporary timbering techniques and construction methodologies. The project has the approach of adapting the timbering architecture to modern standards while preserving the essence of its historical context. The timber is contrasted by using contemporary materials such as corrugated steel for the roof and larger permeable surfaces than usual within this type of construction.

ARCHITECTURAL REFERENCES

The references selected are all relevant to different parts of the project. From building techniques and typology to the theoretical background of each project itself. What is most interesting for the design of the outcome of this thesis is how modern architecture can relate to existing, historic architecture, as well as a place and its history. The research method used by Vardehaugen is highly relevant in that it is a kind of mapping, similar to this thesis, which then results in a modern proposal. At the same time, Zumthor's Allmannajuvet is equally relevant where modern architecture takes centre stage in a historical context, regardless of any type of historical, local architectural typology.

NOTHENG

Vardehaugen : Norway, 2022

Notheng is a study made by the Norwegian architecture firm Vardehaugen where close studies of the Notheng structures in Norway were studied, documented and redrawn. The Notheng structures are sometimes called "the fishermen's church" and it is where the nets used to hang to dry but it was also a social space (Matre Aasarød, 2022). The project is relevant due to its thorough research method and context similar to this master thesis.

STUDENT VILLAGE

Pihlmann Architects: Denmark 2017

Student Village is a transformation and extension of Søgaarden, a traditional half-timbered farm from the 17th century just outside of central Aarhus. The contemporary additional dwellings are interpretations of the existing ones. They follow the same silhouette, however the tectonics and materiality are reinvented with contemporary solutions. The project is of high relevance due to the communication between the contemporary and existing buildings on site and the approach of copying a typology whilst choosing to replace specific elements.

ALLMANNAJUVET

Peter Zumthor: Sauda, Norway 2016

Zumthor's open-air museum project in Allmannajuvet, Norway is relevant to this thesis due to the way he has worked with memory within architecture. The project was highly influenced by the traces of labour in a zinc mine in the Allmannajuvet ravine. Zumthor chose to honour the memory of the workers as well as make visitors aware of the local history and heritage.

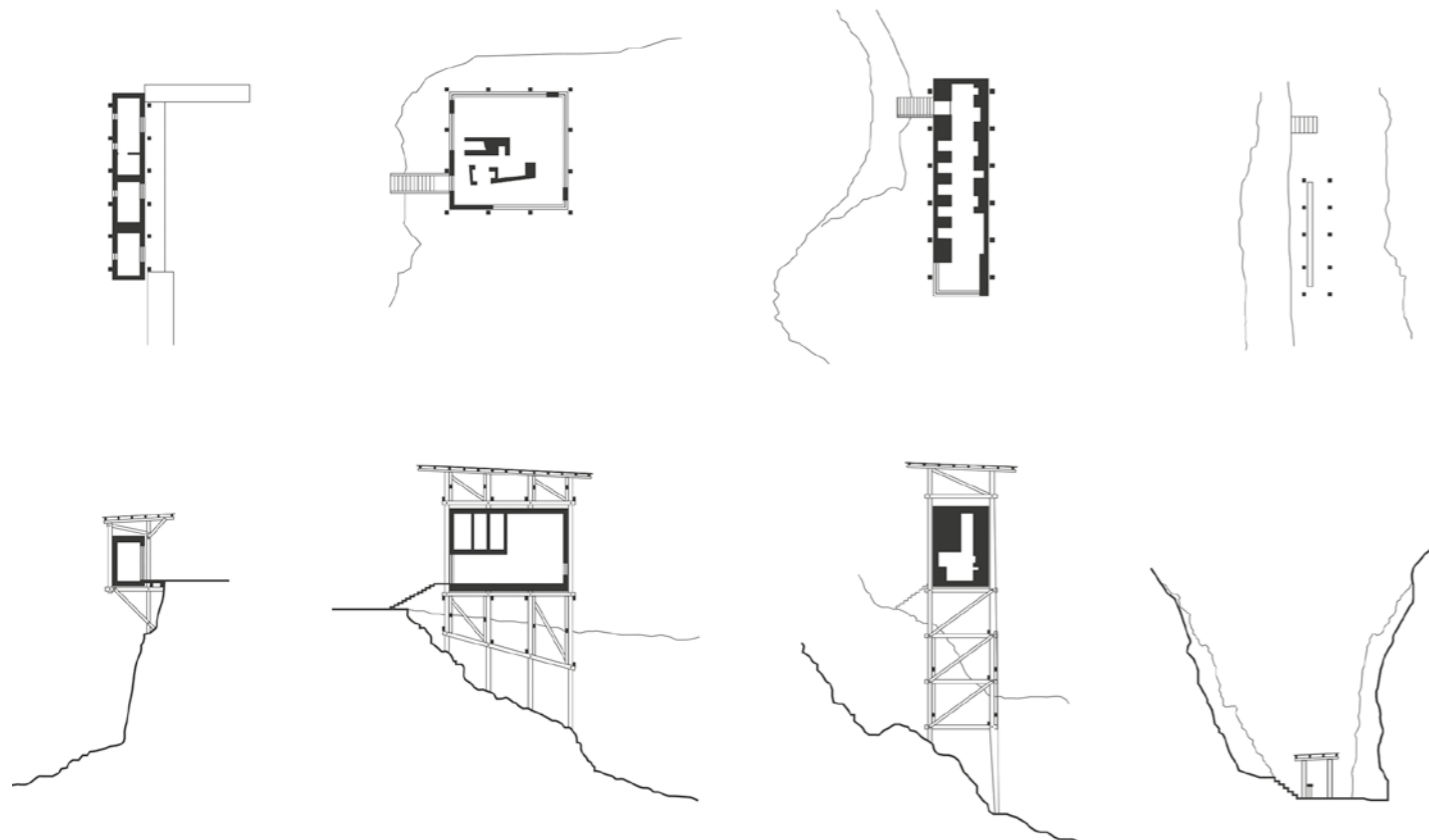

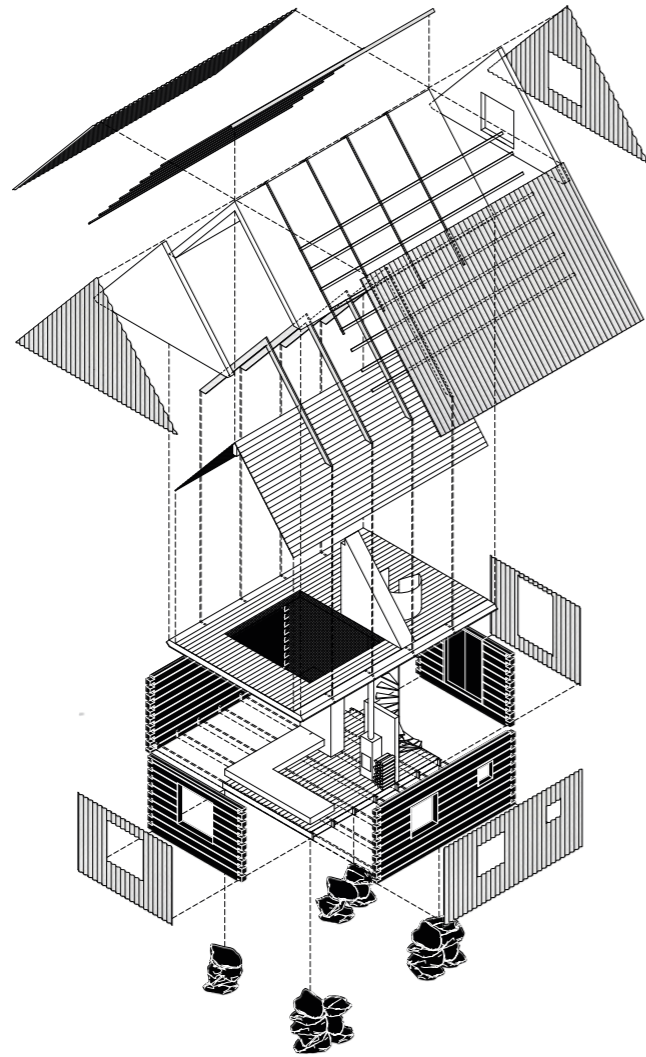

1:200
Exploded diagram of Sjöbod 01

- Translatio
- Imitatio
- Aemulatio

TRANSLATING THEORY INTO DESIGN

In the thesis design work, three strategies for intervention are implemented, referred to as Translatio, Imitatio and Aemulatio. These strategies are described in an adaptive reuse context by Plevoets and van Cleempoel (2019) regarding copying historical references, but are in this thesis adapted to utilise the concept of adaptive reuse whilst working with an empty plot. The reuse within this thesis project is thereby defined solely by translating existing architectural elements and typology without losing the 'Spirit of place'.

Definitions according to Plevoets and van Cleempoel (2019):

Translatio:

Translatio strives for similarity to its historical reference and expresses resemblance to the process of restoration, which can be explained as restoring something to a previously established state.

Imitatio:

Imitatio is a sort of reinterpretation of the existing, striving to be equivalent to its historical reference rather than similar or alike.

Aemulatio:

Aemulatio revolves around creating a clear division or contrast between the old and the new, striving to improve its historical reference or original, thereby respecting the noteworthy historical and architectural values.

When applying the strategies to the design, several parameters are considered. The parts of Translatio are those considered to have strong traditional values. The concept of a sequential value within a group form will be lost due to the cluster being designed all at once instead of evolving (Maki & Ohtaka, 1964). It holds a challenge trying to design a cluster all at once, without the outcome becoming bland or meaningless. Considering this, the resemblance to the existing cluster topography becomes vital to recreate the feeling of shelter and security. An inspirational reference for a cluster design is California Sea Ranch (1964) where the outcome is a collective form that is unified by shared exterior aesthetics. The Sjöbod in the cluster are designed all at once and thereby share a similar expression, in contrast to the existing clusters where the entities often vary in size, form and colour.

The design of the individual Sjöbod is formed through Aemulatio. This vernacular typology is more experimentally

interpreted than the cluster topography. The approach originates from the idea of exploring and introducing contemporary architectural design within Bohuslän's historical context. The aesthetic is inspired by the Zumthor project in Allmannajuvet; creating an industrial expression, using dead material as an exterior and placing a vertical body within the hilly landscape. Additionally, Allmannajuvet embodies a local heritage within a piece of architecture, which is part of the intent of this thesis. However, with the parameter of collecting heritage from several surrounding areas in Bohuslän and introducing it on a bare site. Furthermore, the proposal has another layer that considers its immediate surroundings in Toftenäs, in terms of the materiality of rock and timber. The exaggerated roof contributes to the new expression and silhouette of the Sjöbod, inviting a more dramatic and sacred experience of the simple structures.

The cluster will introduce a new place within the Bohuslän archipelago. However, it will never fully capture the genius loci of a historical cluster due to the absence of historical significance and value. Nonetheless, its resemblance to a traditional cluster will serve as a reminder of the area's historical fishing community while also introducing a collective living environment.

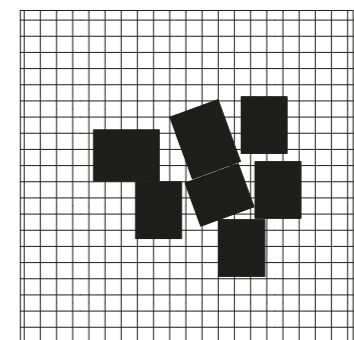
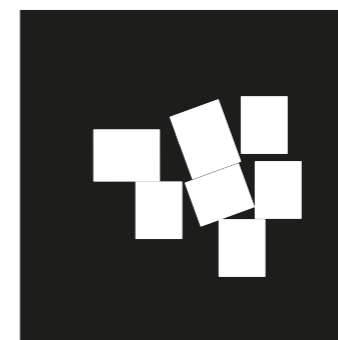
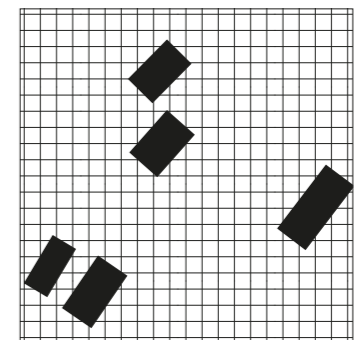
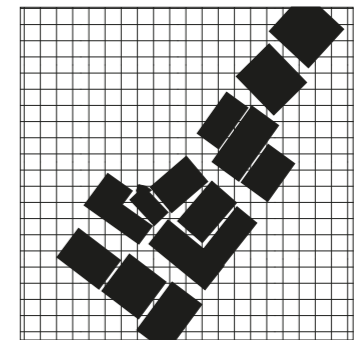
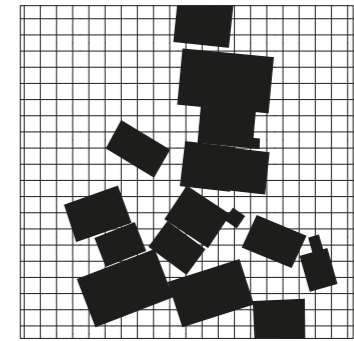
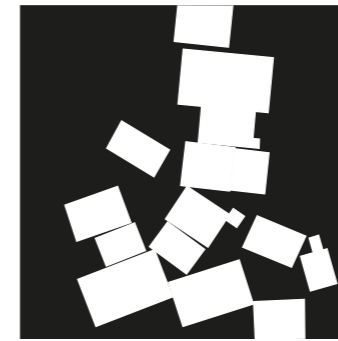

①

Mollösund cluster



The collaging method serves as a dynamic tool for exploring the materiality and proportions of the entity's components. It facilitates the creation of visual representations that transition into tangible physical models. These models offer an in-depth exploration of both the three-dimensional and tectonic aspects, complementing the visual exploration of collaging.

The chosen materials for further exploration—corrugated sheets, timber, and stone—are investigated through physical sketch modelling, enhancing the understanding of their potential applications and interactions.

Bovallstrand cluster



Valsängs Strand cluster







No overhang with eave



No overhang without eave



Overhang gable + long side with eave



Overhang gable with eave

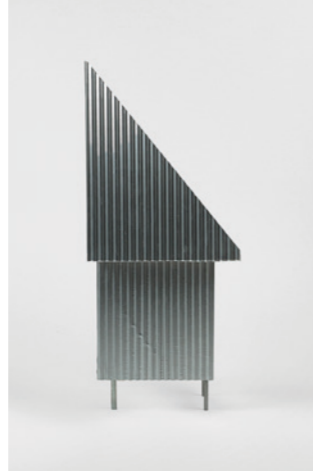

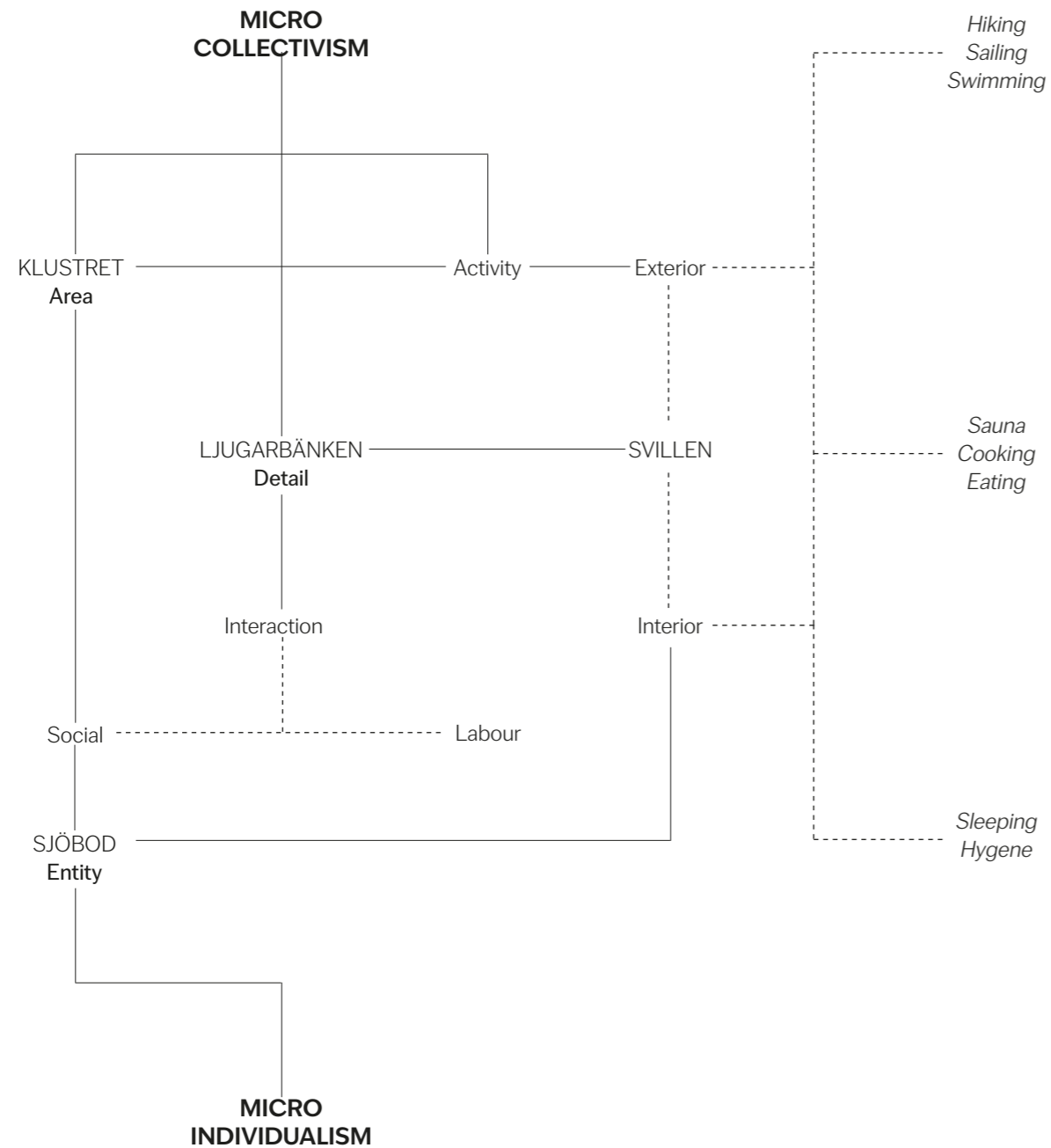

A TRADITIONAL ARRANGEMENT

The dwellings of the Bohuslän archipelago have since the 1900s been built big enough for the property owners to rent a part of the house out. The tenants were often young couples who wanted to live by themselves before building a house of their own. However, during the 20th century, tourism within Bohuslän grew, allowing the locals to rent out, generally, the upper part of their houses during the summer months (Werne & Östnäs, 1983).

The scheme for the thesis reflects this tradition of temporary living. It operates to house common areas and temporary overnight stays for hikers and boaters due to its accessible location in Bohuslän. The program is primitive and the cluster holds no sources for running water and heating is manually adjusted by fireplaces placed in each Sjöbod. There is access to an outdoor kitchen as well as a common fireplace. The cluster includes incineration toilets and an outdoor shower of collected rainwater. Additionally, one of the Sjöbodar, a historical exhibition of the local fishing community will be displayed.

Partly, the program aims to underline the problematization of town citizens investing in part-time households in Bohuslän, making it challenging for the municipalities to keep the communities thriving all year round. However, it also allows people to explore the beautiful environment without being a property owner and perhaps attracts more people to live in Bohuslän permanently. It offers the concept of ecotourism (Fennell, 1999); inviting the public to experience local history and nature, whilst having a low impact on its environment. This type of minimalistic living resulting from ecotourism plays a role in the thesis's sustainability focus.

- Sjöbod 01: Sleep
- Sjöbod 02: Canteen
- Sjöbod 03: Sauna
- Sjöbod 04: Sleep
- Sjöbod 05: Sleep
- Sjöbod 06: Exhibition
- Sjöbod 07: Toilets



THE CLUSTER

The cluster design proposed is shaped by the application of Translatio, and seeks to stay in similarity to its historical reference of the analysed clusters in Mollösund, Bovallstrand and Valsängs Strand. The design aims to create and encourage exploration of unexpected spaces within the cluster, similar to the Mollösund cluster. Svillen is exaggerated within the cluster as the eaves protrude out 1,5 - 2 metres from the body of the house. This offers a greater degree of shelter compared to the original clusters and thereby maintaining a more expansive outdoor social area. Similar to the original boathouses, the design of Sjöbodarna is of domestic size, varying between two different scales.

Within the cluster, there is an undermined 'main' passage, inspired by the Bovallstrand cluster. The passage is peeled off the corrugated sheet facade, exposing the timber structure beneath. Along the timber passage, Ljugarbänkar ("Liar's benches") are placed, inviting the visitor to relax against the wooden walls.

The cluster is anchored by a long boat pier extending towards the horizon. The wooden pier material seamlessly integrates with the rocky ground, appearing at various points within the cluster for easier accessibility and a more level deck for the Sjöbodar.

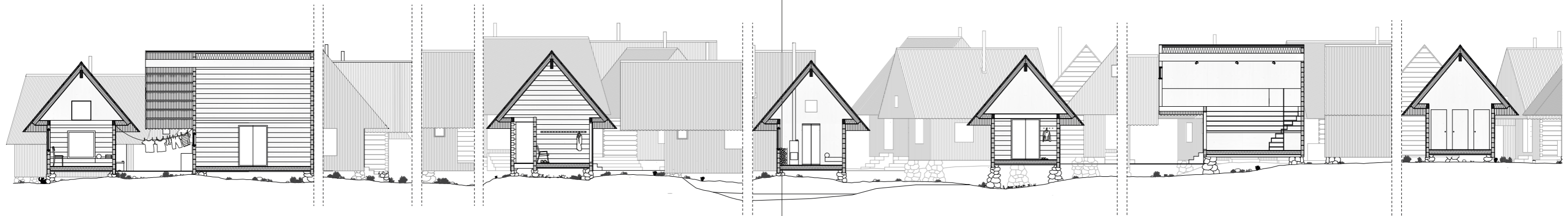



- Sjöbod 01: Sleep
- Sjöbod 02: Canteen
- Sjöbod 03: Sauna
- Sjöbod 04: Sleep
- Sjöbod 05: Sleep
- Sjöbod 06: Exhibition
- Sjöbod 07: Toilets
- 08: Kitchen





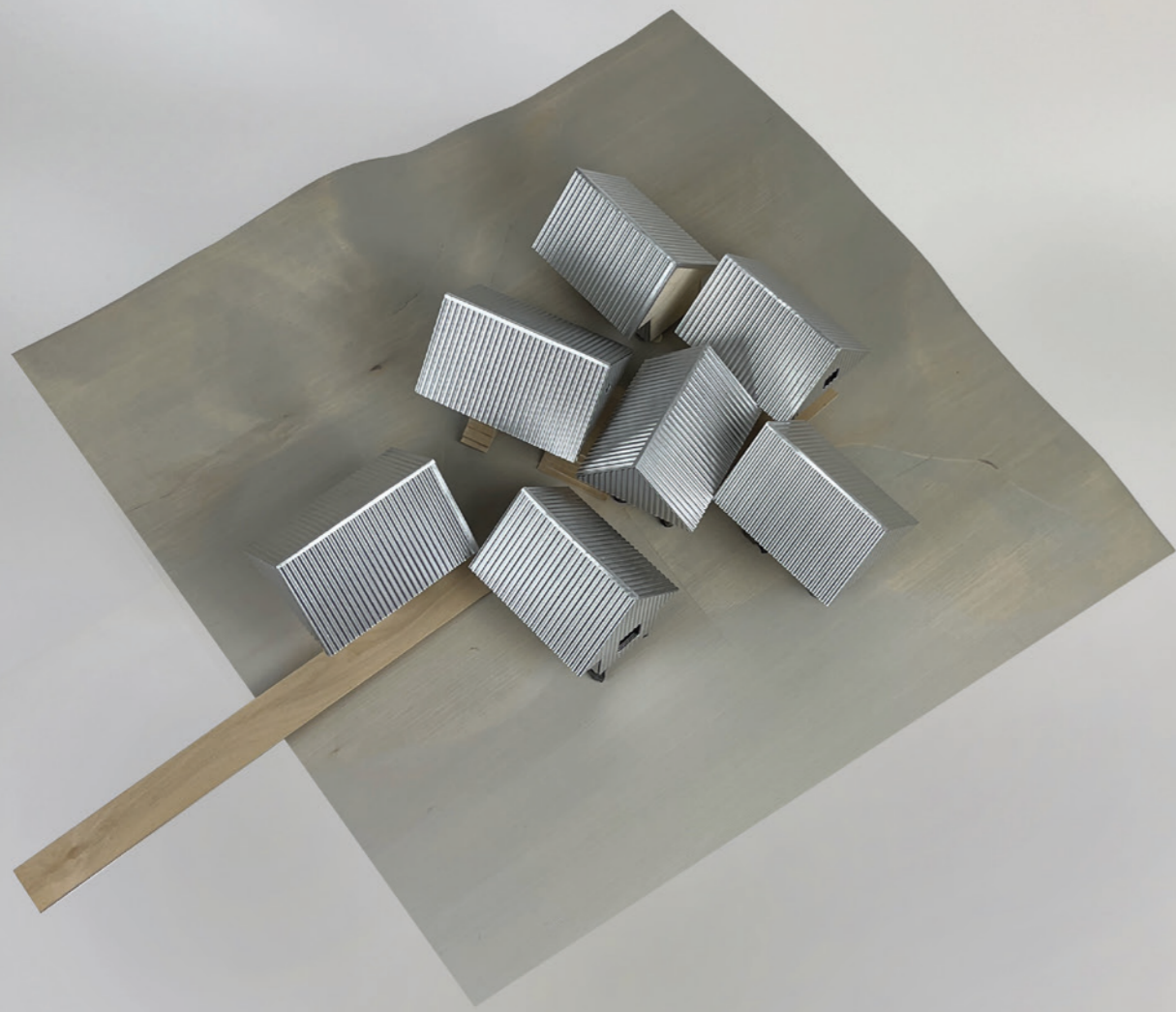



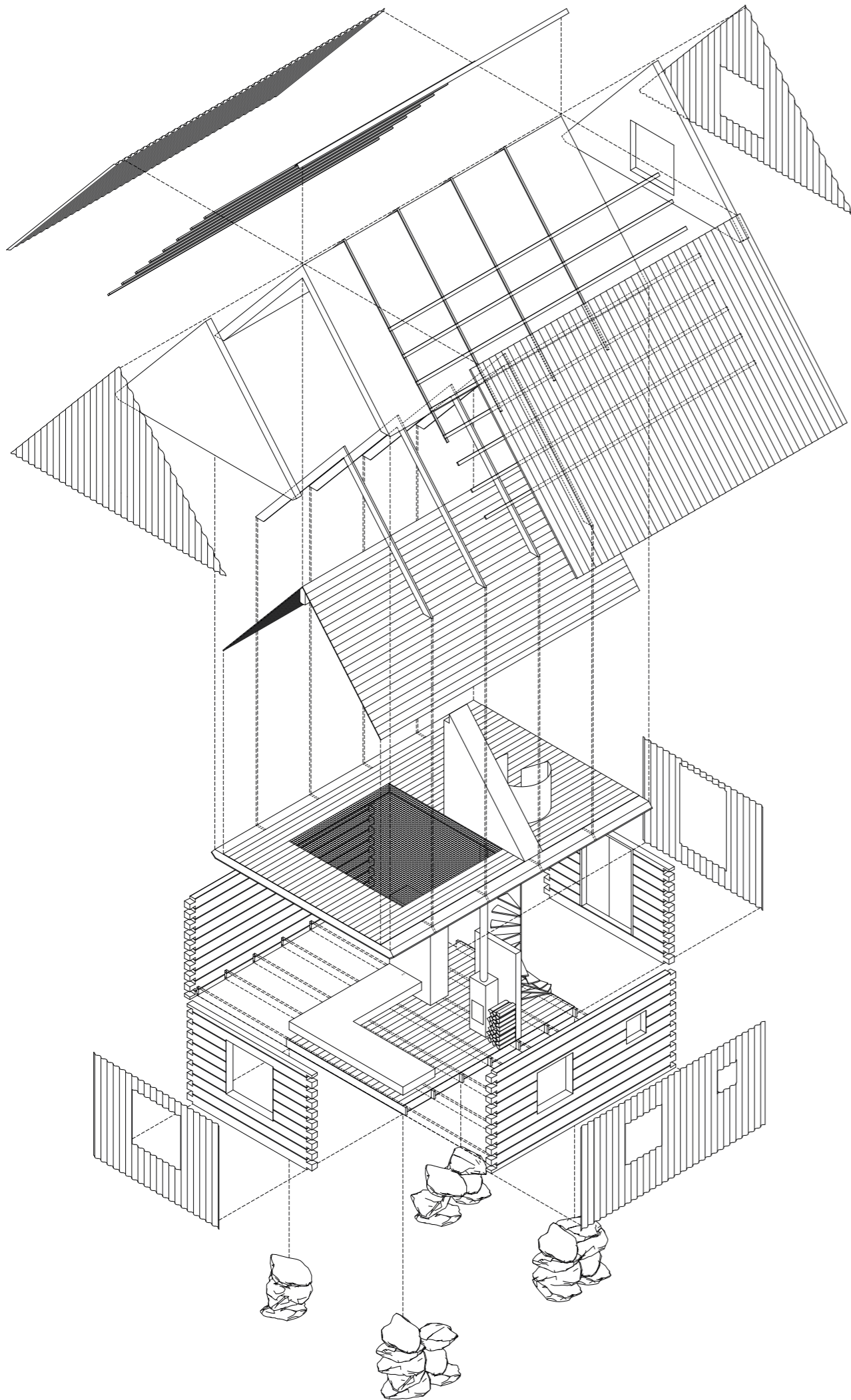

THE SJÖBOD

The Sjöbod design represents a reinterpretation of the traditional boathouses, incorporating the design strategies of *Translatio*, *Imitatio*, and *Aemulatio* applied to different aspects of the building's tectonics. The load-bearing structure is made of logged timber resting on a stone foundation, this would be referred to as a *Translatio*, staying similar to or preserving the traditional building techniques commonly used in the local areas. The form of the Sjöbod adapts an approach of an *Imitatio*, endeavouring to become similar to the shape of its historical reference, but with different features, the uniform corrugated material abstracts and enhances the shapes of the Sjöbod. The roof is applied with *Aemulatio* and exaggerated in proportion to the body to extend *Svillen* and introduce a new expression. Therefore, the solution for the roof structure differs from the original logged timber method. Instead, the roof is supported by trusses that rest upon the logged timber walls, supported by a glulam beam on the rock.

Within each Sjöbod, there is an individual fireplace for local heating. The houses are insulated naturally by the timber walls and hold insulation within the roof, allowing for overnight stays during colder periods of the year. All of the Sjöbodar that operate as sleeping cabins contain a loft; activating the entire space of the structure.

The choice of material is consciously limited to a palette of timber, plywood, stone, stainless steel and glass. The exterior expression varies between logged heartwood pine and corrugated sheets. The local logging structures the thesis has studied have an impressive lifespan, reflecting this sustainable way of construction. The foundation of rock stilts is also a sustainable choice due to it having a low impact on the site environment.

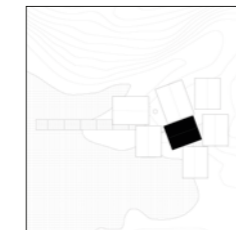

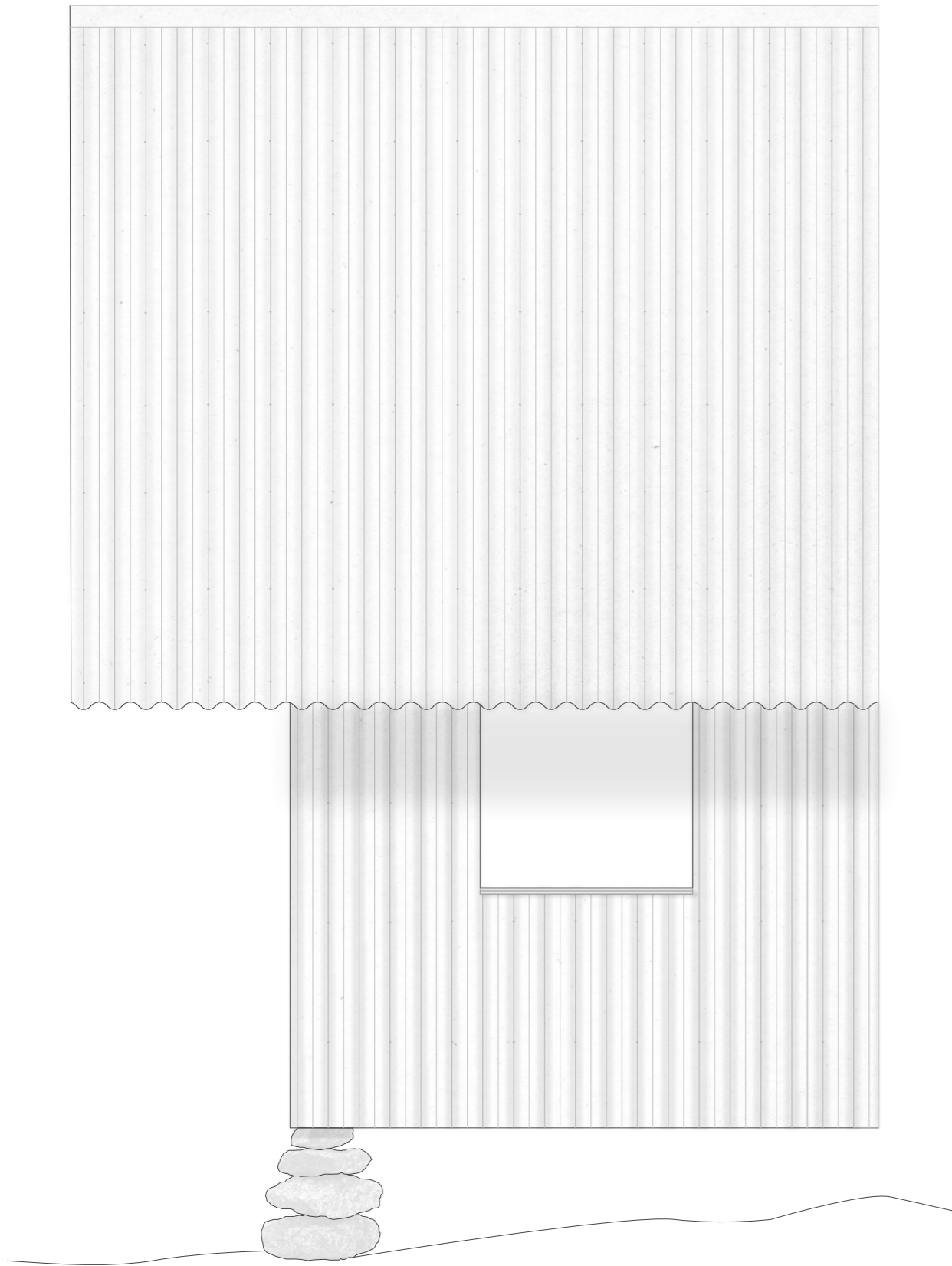

01. ROOF
 38 sinus corrugated steel
 28x70 batten
 28x70 batten
 17x120 roof boards
 underlayment
 195 x75 beam | insulation
 13x120 wood panel, pine

02. WALL
 38 sinus corrugated steel
 152 timber

03. FLOOR
 20x120 wood floor, pine
 195x45 beam | insulation
 20 Minerit

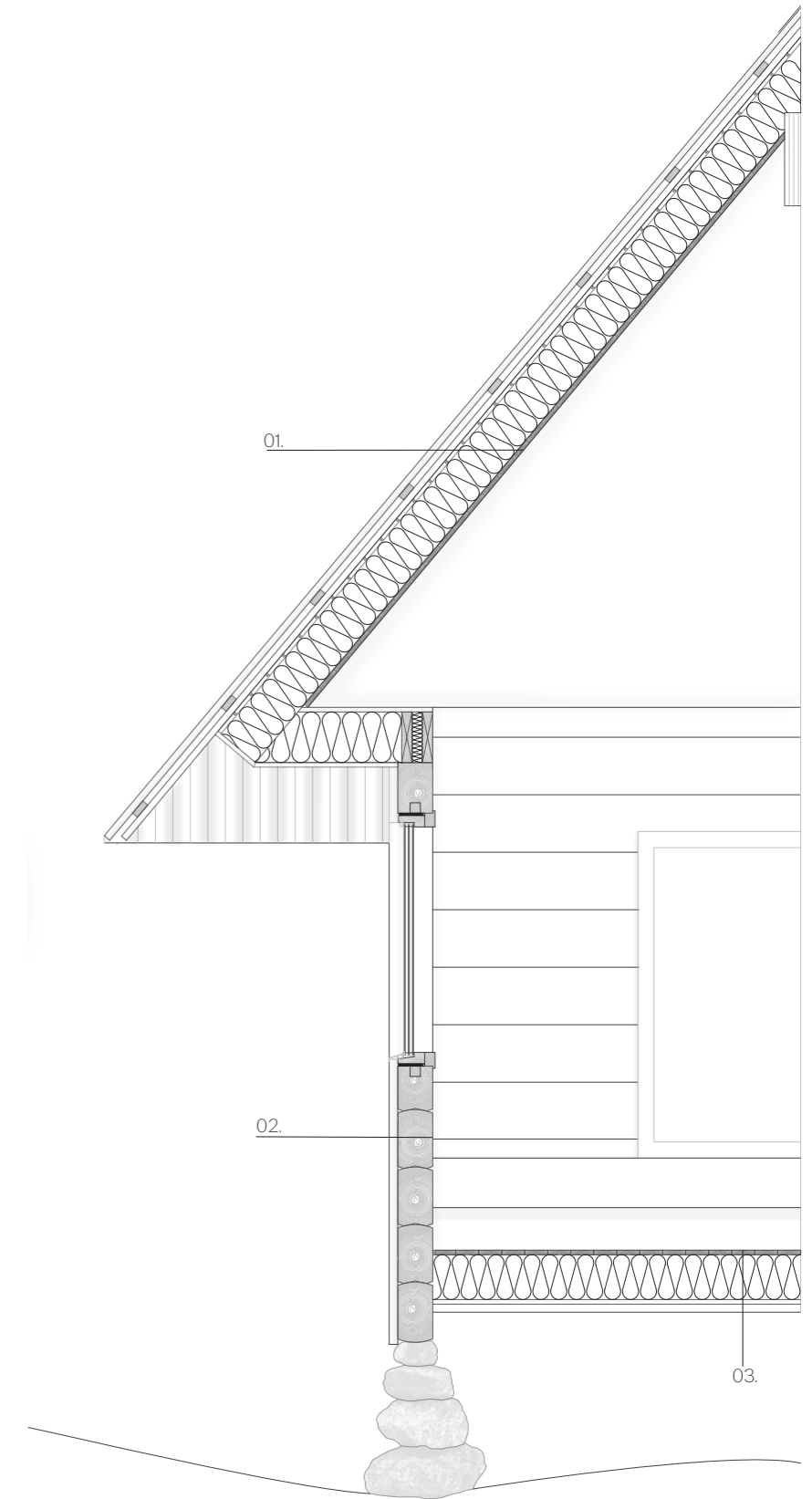

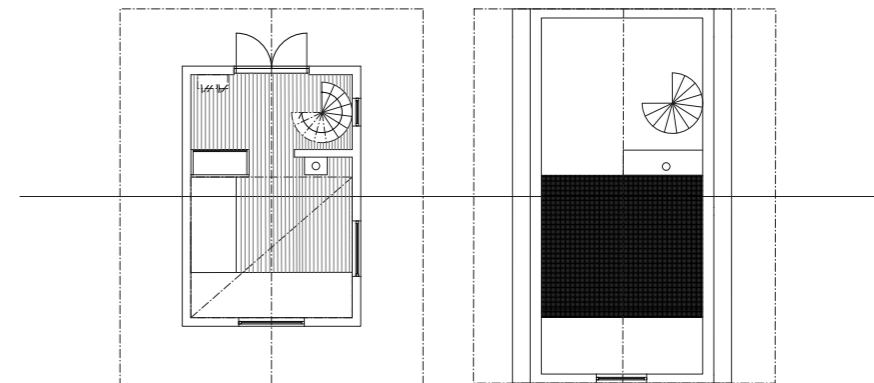
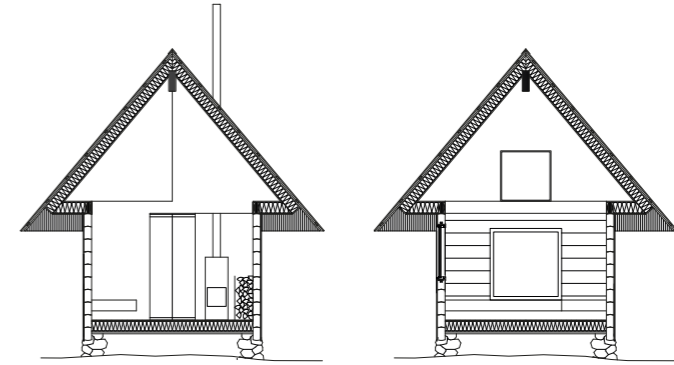
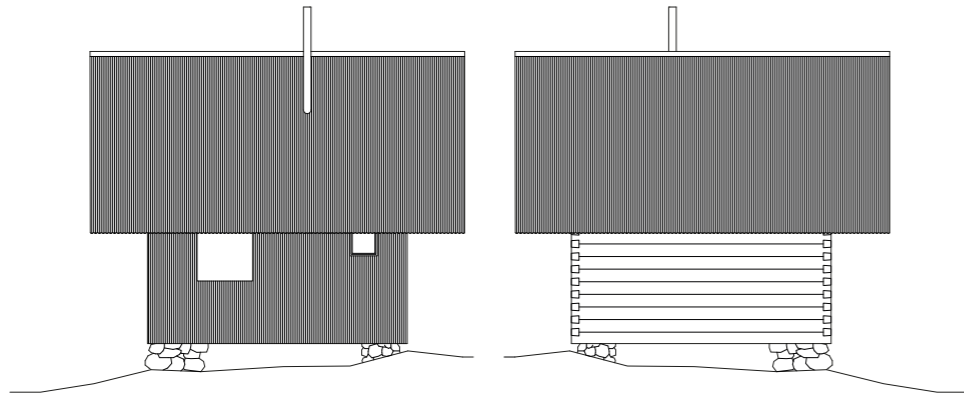





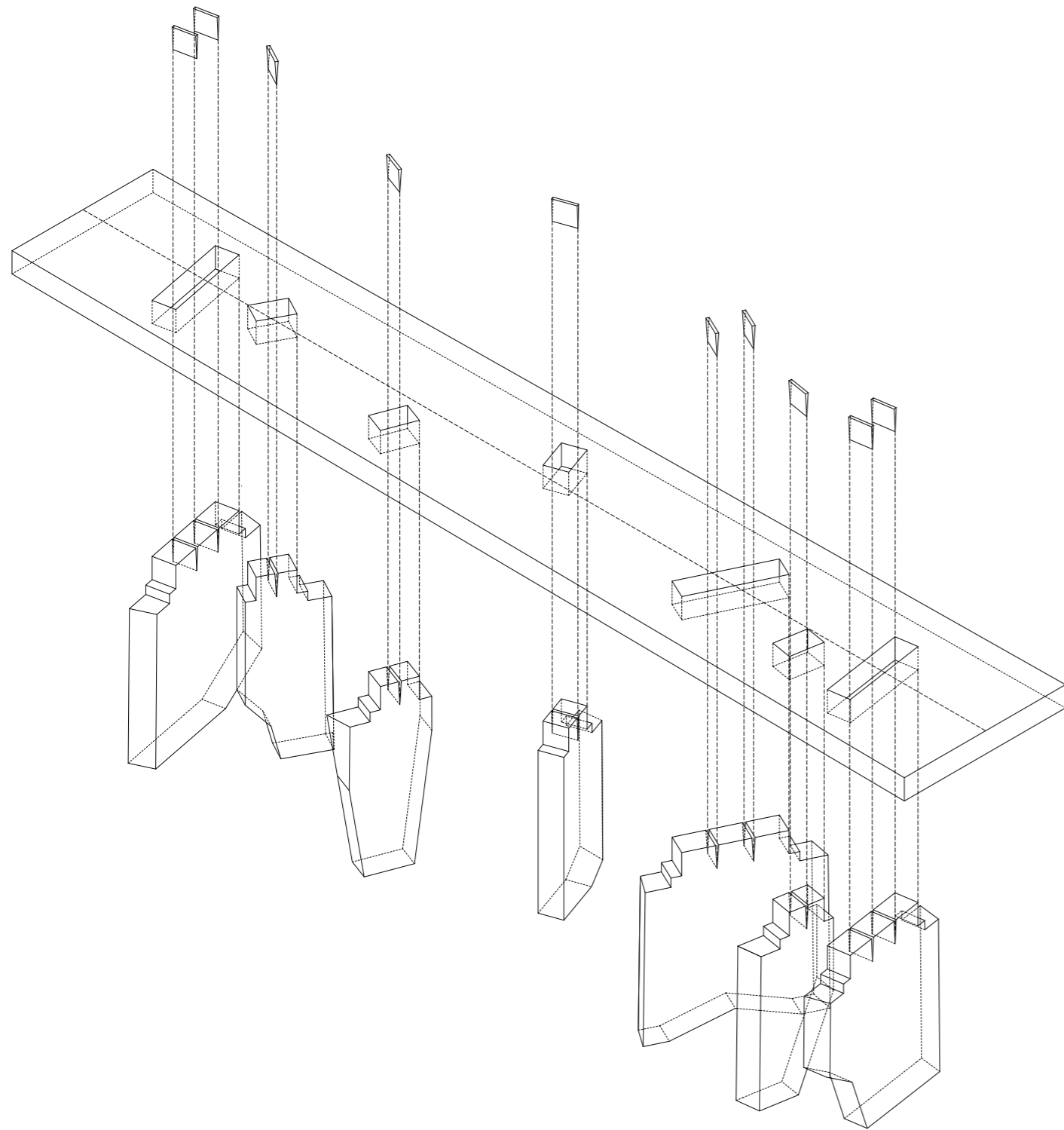

THE LJUGARBÄNK

This imitation of the liar's bench works both as a concept model of the cluster design proposal and as a physical tangible object, representing the values of the Bohusläns archipelago topography and culture. Ljugarbänken is a symbol of a social community that in the new context can connect the new design with the heritage of the old fishing community.

The bench is constructed according to handicraft tradition, with strong Swedish heartwood pine that is organically harvested in northern Sweden. The timber wood is naturally thicker closer to the tree trunk and smaller closer to the crown. The legs are placed slightly angled to each other, to imitate the kind of inconsistency of the cluster typology, as well as generate stability. Cutouts are made to make each leg have its identity in the collective whole.

The idea of creating Ljugarbänken as a complement to the cluster grew from the idea of representing the historical and cultural heritage of the fishing community within the project. Handcrafting a 4-metre solid heart pine plank into a piece of furniture has been rewarding to the project outcome in terms of knowledge in fine carpentry and joinery. Furthermore, Ljugarbänken became the starting point for the project; somehow reinterpreting the Bohuslän cluster topography through an object.



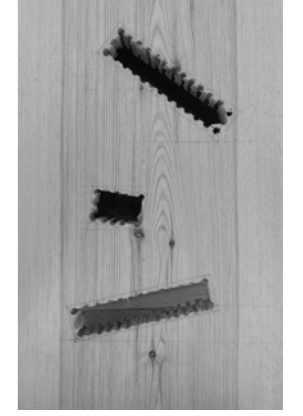
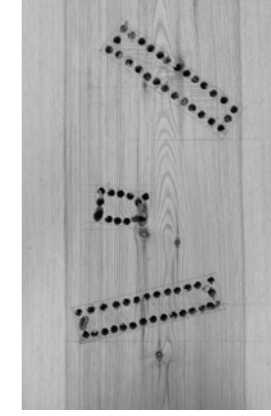

Process

Result

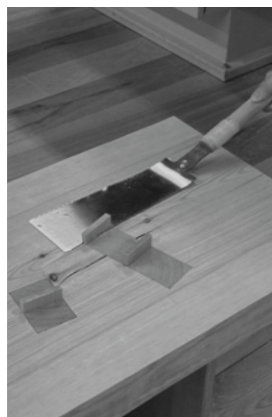
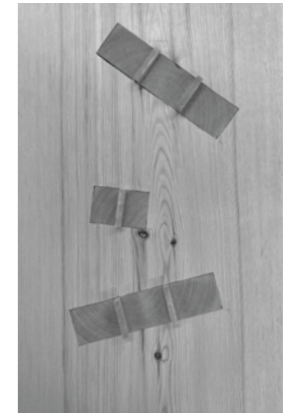



SUMMARY

The thesis has attempted to answer the two questions:

'How can contemporary architecture evoke the cultural and architectural heritage of the Bohuslän fishing villages?'

'What characterises the vernacular 'Sjöbod' cluster typology, and what can architecture learn from it?'

The questions have been explored through historical literature and architectural research, modelling, sketching and reference studies, and further developed in a design proposal. The proposal holds parts of 3 different scales; the Cluster, the Sjöbod and the Ljugarbänk. The project has been conducted on a rural site within a nature reserve, in an environment connected to the research discourse.

The project is presented through process material, such as collages and physical models. The final material is based on the various physical models developed into perspective renders, supported by architectural drawings. The design strategy is based on ideas and theories of adaptive reuse whilst striving for a site-specific formation. Inspiration for the design has been found in reference projects with a strong connection to heritage, whilst introducing contemporary solutions.

DISCUSSION + REFLECTION

Reflecting on the studies of the boathouse clusters within Bohuslän, the traces of the fishing villages serve as a time capsule, representing an era when such architecture was predominant, creating a certain nostalgia for lost times. Throughout the research, the question of why similar clusters are not constructed today has been prominent. Today, security regulations and economic considerations significantly impact the building industry, thereby affecting the essence of intangible values. This thesis reflection can conclude several interesting aspects of the traditional clusters that can be inspirational for contemporary architecture.

A distinctive trait of the boathouse clusters in Bohuslän is that they share the void between them instead of built elements. The bodies never physically connect but are positioned so closely that at times, one could barely squeeze in between them. This sort of labyrinth or random placing, created sequentially throughout time, causes spontaneous spaces for people to socialise and exercise different shores together. These intangible values are generated merely through the shape of the cluster and the positioning of the sjöbod in correlation to each other. This domestic way of designing has significant qualities that this thesis has aimed to prioritise and evoke.

The ideals of individualism and independence are strong in modern Western societies, however every individual living within the civilisation is dependent on prominent institutions taking care of its inhabitants, and social interactions between individuals are more sporadic. The boathouse cluster and the fishing community examined in this thesis are representational of a significantly smaller scale and more intimate social community. Individuals were dependent on each other and forced to work together to be able to survive. This makes it an interesting building typology to examine for modern-day architects and planners.

Introducing a contemporary design proposal within a historical context can be controversial and evoke strong emotions in the recipient. Questions that have arisen during the project include: Is it possible to encapsulate architectural heritage without resorting to pastiche or producing inferior imitations? and, To what extent can a historical typology be modernised through design without compromising its resemblance to its predecessor?

Through the implementation of various design strategies, the thesis attempts to evoke awareness of the architectural heritage of the Bohuslän fishing villages and acquire a deeper appreciation for both the tangible and intangible elements of heritage architecture.

The navigation between trying to mimic the historical reference and overstepping boundaries with bold, uncontextualized expressions is a delicate balance. However, architectural identity is lasting but not static, posing the question: how can identity continue to develop within architecture? Exploring the interplay of architectural eras and allowing structures to pay homage to a place's identity while adapting to contemporary demands has led to continuous reevaluation and reconstruction during the project. This ongoing discourse, influenced by design methodologies, has temporarily been shaped by this thesis's present understanding, yet it remains open to further evolution.

The thesis could benefit from a deeper exploration of how the project's program would function in reality, especially regarding the involvement of private and public stakeholders. Currently, the focus leans heavily towards architecture, treating the program as a means to refine design strategies. However, aspects like accessibility and flexible planning within limited space could have received more attention. Additionally, potential outcomes of the cluster, such as shared roof elements or increased permeability, warrant further investigation. Further research on the discourse could have involved examining the integration of architectural infill within existing clusters, establishing a tangible boundary between historical and contemporary elements. This approach invites direct comparison between new and existing architecture, offering insights into adaptation within historical contexts.

Literature

Aronsson et. al. (2001). *Tradition i trä: En resa genom Sverige*. Byggförlaget, Stockholm.

Fennel, D. (1999). *Ecotourism: An Introduction*. Routledge.

Gehl, J. (2011). *Life between buildings: Using public space*. Island Press.

Hansson, G. D. (2000). *Förlusten av Norge*. Albert Bonnier Förlag

Håkansson, S.G. (2014). *Från Stock till Stuga*. Massolit Förlag.

Maki, F. (1964). *Investigation in Collective Form*. Washington University, School of Architecture.

Norberg-Schulz, C. (1996). *Genius loci: Towards a phenomenology of Architecture*. Rizzoli.

Pettersson, M. (2013a). *Att bygga varsamt i det bohuslänska bergslandskapet* (thesis). Chalmers University of Technology, Gothenburg.

Plevoets, B., & Cleempoel, K. V. (2019). *Adaptive reuse of the built heritage: Concepts and cases of an emerging discipline*. Routledge.

Werne, F., & Östnäs, S. (1983). *Bygge i bohuslän*. Wahlström & Widstrand.

Zumthor, P., Lending, M., & Binet, H. (2018). *A feeling of history*. Scheidegger & Spiess.

Lectures

Matre Aasarød, H. (2022). *Vardehaugen*. A-prat. Gothenburg.

Online Articles

Gustafsson, A. (2022). *Sotenäs Har högst Andel fritidshusområden i Sverige*. Lysekilsposten. <https://www.lysekilsposten.se/artikel/sotenas-har-hogst-andel-fritidshusomraden-i-sverige/>

Svedberg, R. (2013, February 13). *Turisterna Sviker Sotenäs*. Bohuslänningen. <https://www.bohuslaningen.se/nyheter/turisterna-sviker-sotenas.62f46dfd-20f6-4061-b4fa-65a81c4d8583>

Webpages

Bebyggelseregistret (bebr). Bebyggelseregistret (BeBR) - Riksantikvarieämbetet. (2006). Retrieved May, 2024. <https://www.bebyggelseregistret.raa.se/bbr2/anlaggning/visaHistorik.raa?anlaggningId=21300000013122&page=historik&visaHistorik=true>

Månads-, årstids- och årskartor. SMHI. (2024). Retrieved May, 2024. <https://www.smhi.se/data/meteorologi/kartor/normal/manadsmedeltemperatur-normal/manad/januari>

Toftenäs. Länsstyrelsen Västra Götaland. (2024). Retrieved May, 2024. <https://www.lansstyrelsen.se/vastra-gotaland/besoksmal/naturreservat/toftenas.html?sv.target=12.382c024b1800285d5863a8b2&sv.12.382c024b1800285d5863a8b2.route=%2F&searchString=&counties=&municipalities=&reserveTypes=&natureTypes=&accessibility=&facilities=&sort=none>

Toftenäs vandringsled. Tjörn kommuns logga, till startsidan. (2024). Retrieved May, 2024. <https://www.tjorn.se/kultur-fritid-och-turism/natur-och-friluftsliv/vandra/toftenas-vandringsled>

Images

Bohusläns Museum. (2014). *Fiske efter håkarring vid Tromsö med kuttern ISLAND 1917*. Digitalt Museum. photograph. Retrieved October 2023, from <https://digitaltmuseum.se/011014289471/fiske-efter-hakarring-vid-tromso-med-kuttern-island-1917>.

Zumthor, P. (2016). *Allmannajuvet*. The Architectural Review. drawing. Retrieved March 2024, from <https://www.architectural-review.com/buildings/allmannajuvet-zinc-mine-museum-in-norway-by-peter-zumthor-the-progeny-of-an-artist-architect>

All other images and figures not listed are produced and owned by the authors.