

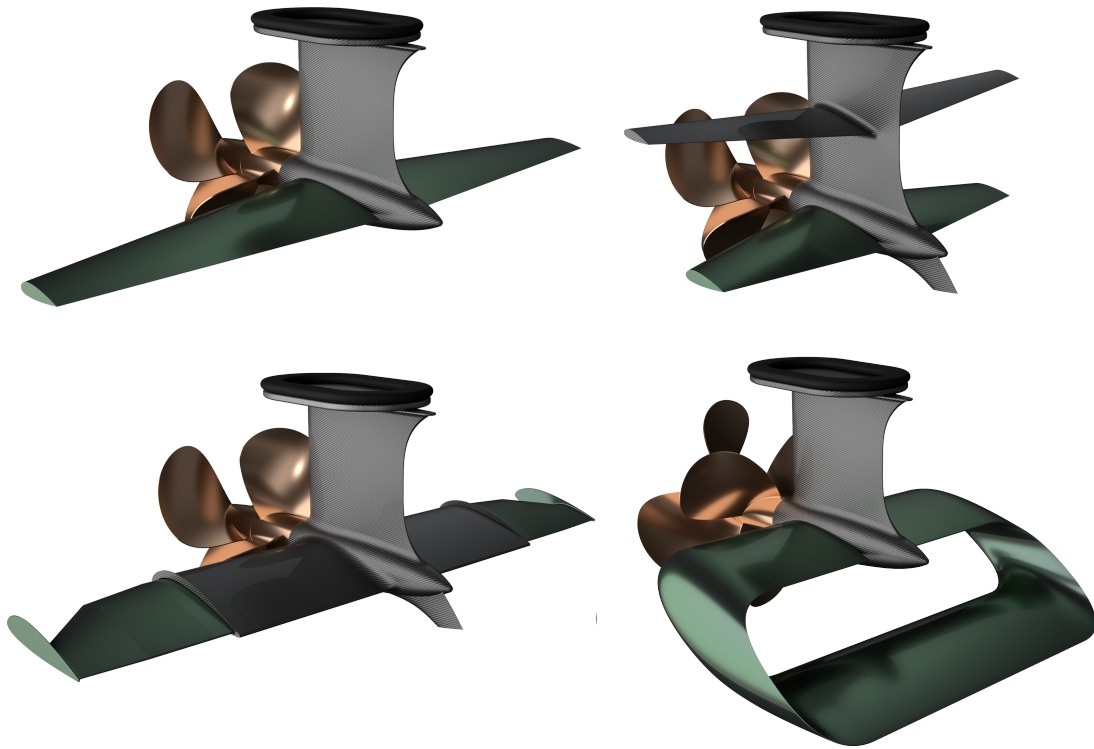

CHALMERS
UNIVERSITY OF TECHNOLOGY



Hydrofoils on pod for electrical propelled low speed vessels

Conceptual development and efficiency investigation of hydrofoils on pod for leisure and commercial vessels

Master's thesis in Product Development

DENNIS KÖHLBERG
HELENA WEINGARTEN

DEPARTMENT OF INDUSTRIAL AND MATERIAL SCIENCE

CHALMERS UNIVERSITY OF TECHNOLOGY

Gothenburg, Sweden 2022

www.chalmers.se

MASTER'S THESIS 2022

Hydrofoils on pod for electrical propelled low speed vessels

Conceptual development and efficiency investigation of hydrofoils on pod for leisure and commercial vessels

DENNIS KÖHLBERG
HELENA WEINGARTEN



CHALMERS
UNIVERSITY OF TECHNOLOGY

Department of Industrial and Materials Science
Division of Product Development
CHALMERS UNIVERSITY OF TECHNOLOGY
Gothenburg, Sweden 2022

Hydrofoils on pod for electrical propelled low speed vessels
Conceptual development and efficiency investigation of hydrofoils on pod for leisure and commercial vessels
DENNIS KÖHLBERG
HELENA WEINGARTEN

© DENNIS KÖHLBERG, HELENA WEINGARTEN, 2022.

Supervisor/Examiner: Ola Isaksson, Department of Industrial and Material Science
Industrial supervisor: Lennart Arvidsson, Volvo Penta

Master's Thesis 2022
Department of Industrial and Materials Science
Division of Product Development
Chalmers University of Technology
SE-412 96 Gothenburg
Telephone +46 31 772 1000

Cover: Visualisation of the four concepts in the concept catalogue, starting from the upper left, *Single*, upper right *Odd dual*, bottom left *Telescopic*, bottom right *Come Around*, all viewed obliquely from behind.

Typeset in L^AT_EX
Printed by Chalmers Reproservice
Gothenburg, Sweden 2022

Hydrofoils on pod for electrical propelled low speed vessels
Conceptual development and efficiency investigation of hydrofoils on pod for leisure and commercial vessels

DENNIS KÖHLBERG, HELENA WEINGARTEN

Department of Industrial and Material Science

Division of Product Development

Chalmers University of Technology

Abstract

The marine industry is facing changes, decreasing the emissions and environmental footprint of leisure and commercial vessels, implying imperative aspects to decrease the energy required to propel the vessel and the implementation of electrical propulsion systems. Hydrofoils have in the past been utilised to lift hulls out of the water, decreasing the energy required to propel the vessel, although this requires advanced system control. This project investigates the beneficial aspects of affecting the hull with a lift force at the stern, without lifting the entire hull out of the water at a primary speed of $15kn$. The project develops concepts of hydrofoils implemented on the pod, focusing on a total lift-force of $7500N$, decreasing the resistance of the hull up to 12%, evaluating and validating different characteristics and solutions.

Starting the product development with an extensive design-space and decreasing it successively as information and knowledge are generated and gathered, concluding and scoring concepts to generate the concept catalogue of four concepts. These were concluded by performing extensive calculations regarding hull resistance with the method of Savitsky, and forces generated by wings/hydrofoils with generic equations and 2D-Computational Fluid Dynamics. During the development, material research and evaluation in regard to the concepts have extensively been explored and conducted. Concluding reinforced POM-C, aluminium alloys, and thermoset composites as viable materials for the developed concepts. Reinforced POM-C with the manufacturing method of injection moulding is concluded as the most cost-effective option, aluminium alloys with the manufacturing method of die casting as a recyclable option, and thermoset composites with the manufacturing method autoclave to enable complex geometrical designs with low weight and high strength.

The result was concluded as four different concepts in the concept catalogue, accounting for their properties and characteristics. The concepts are the *Single*, *Comes Around*, *Odd Dual*, and *Telescopic*. The *Single* is characterised by its simplicity and low-risk design. *Comes Around* is characterised by its continuously swept wing, minimising vortices generated and increasing the efficiency. *Odd Dual* is characterised by decreasing the spaciousness while maintaining similar efficiency as the *Single* concept. *Telescopic* is characterised by its adjustable span width, enables the generated lift to be adjusted accordingly, and enables a compact product when operated in shallow waters.

Keywords: Hydrofoils, Foil, Electric propulsion, Pitch, Roll, Angle of Attack, Safety, Energy efficiency, Hull, Vessel, Conceptual development, Savitsky, Lift & Drag force.

Acknowledgements

This master's thesis work regarding product development of *Hydrofoils on pod for electrical propelled low speed vessels*, has successfully been executed by two students, both studying a master's in Product development at Chalmers University of Technology. The project has been carried out for 20 weeks during the spring of 2022, where this is the thesis of partition completion of master's thesis work of 30 credits at the department of Industrial and Material Science. We want to thank the experts and people who helped and supported us during the project.

Firstly, we want to address our great gratitude to our supervisor and examiner Ola Isaksson at Chalmers University of Technology, for the continuous support and outstanding feedback throughout this project, your expertise and knowledge are truly amazing.

Secondly, we want to thank the external domain experts Erik Kullgren at Elitkomposit AB, Alex Abolfazl Shiri at SSPA Sweden AB, and the author of *Principle of Yacht Design* Lars Larsson. Your hospitality and expertise have truly been valuable for this project.

Finally, we want to thank the Company Volvo Penta and the department Diesel Transmission for making this project a possibility, and address our great gratitude to our supervisor Lennart Arvidsson at Volvo Penta, your passion, mindset, and advanced knowledge have not only made this project an unforgettable journey but also enriched our minds. Further, we want to thank the experts at Volvo Penta, Johan Tell, Lars Johansson, and Jon Wingren for your knowledge and guidance in the project, your positive mindset inspires us.

The last five years at Chalmers University of Technology have been a rewarding, fun, and an amazing journey, and we are grateful for the people making this time unforgettable.

Dennis Köhlberg & Helena Weingarten, Gothenburg, June 2022

List of Acronyms

The acronyms listed alphabetically below are used in the thesis:

AoA	Angle of Attack
AR	Aspect Ratio
CAD	Computer Aided Design
CFD	Computational Fluid Dynamics
CFRP	Carbon Fibre Reinforced Polymer
CG	Centre of gravity
DNV	Det Norske Veritas
FEA	Finite Element Analysis
FMECA	Failure Mode Effects and Critically Analysis
GFRP	Glas Fibre Reinforced Polymer
IMO	International Maritime Organisation
NACA	National Advisory Committee for Aeronautics
PCM	Pairwise Comparison Matrix
PREn	Pitting Resistance Equivalent number
RPN	Risk Priority Number
RTM	Resin Transfer Moulding
SDG	Sustainable Development Goals
SMC	Sheet Moulding Compound
TP	Taper Ratio

Nomenclature

The variables listed below are used in the thesis:

Variables

C_L	Lift coefficient [-]
C_D	Drag coefficient [-]
C_M	Pitching moment coefficient [-]
C_P	Pressure coefficient [-]
C_{D0}	Pressure drag coefficient [-]
C_{Df}	Skin friction drag coefficient [-]
C_{Di}	Induced drag coefficient [-]
C_{Dmisc}	Miscellaneous drag coefficient [-]
C_{L2D}	Lift coefficient in 2D [-]
C_{M2D}	Pitching moment coefficient 2D [-]
C_{P2D}	Pressure coefficient [-]
σ	Cavitation number [-]
P_{ref}	Surrounding pressure [Pa]
P_{vap}	Vapour pressure of medium [Pa]
V_{ref}	Free flow speed of medium [m/s]
α	Angle of attack [deg]
D_{foil}	Drag force foil [N]
F_{foil}	Lift force foil [N]
Re	Reynolds number [-]
e	Oswald factor [-]
b	Span Width [m]
S	Planform area [m ²]
c	Chord length [m]

Variables for Savitsky method

Δ_0	Mass displacement [lb]
N	Component of resistance force normal to bottom [lb]
T	Propeller thrust [lb]
D_f	Frictional drag force component [lb]
a	Distance between D_f and CG [ft]
c	Distance between N and CG [ft]
d	Distance, vertical depth of trailing edge of boat [ft]
f	Distance between T and CG [ft]
τ	Trim angle [°]
ϵ	Inclination of thrust line relative to keel line [°]
C_v	Speed coefficient [-]
V	Horizontal velocity [fps]
b	Beam of planing surface [ft]
g	Standard gravity [ft/sec ²]
β	Deadrise angle [°]
$C_{L\beta}$	Lift coefficient, $\beta > 0$ [-]
Δ	Mass displacement [lb]
ρ	Mass density of water [lb/ft ³]
C_{L0}	Lift coefficient, $\beta = 0$ [-]
λ	Mean wetted length-beam ratio [-]
p_d	Average Dynamic pressure [lb/ft ²]
V_1	Mean bottom velocity [fps]
ν	Kinematic viscosity [ft ² /sec]
R_n	Reynolds number [-]
φ	Mass density of water [lb*sec ² /ft]
γ	Specific weight of water [lb]
C_f	Friction drag coefficient [-]
C_p	Distance of center of pressure [-]
D	Total drag of hull [lb]
LCG	Length from stern to center of gravity [ft, m]
VCG	Height from stern to center of gravity [ft, m]
LCG _{foil}	Length to center of gravity from foil [ft, m]

VCG_{foil}	Height to center of gravity from foil [ft, m]
LWL	Length of hull at waterline [m, ft]
BWL	Width of hull at waterline [m, ft]

Variables for Material Indices

m	Mass [kg]
A	Area [m ²]
L	Length [m]
a	Semi-minor axis [m]
b	Semi-major axis [m]
t	Wall thickness [m]
E	Young's modulus [Pa]
I	Second moment of area [m ⁴]
S	Bending stiffness [N/m]
C	Special case variable [-]
C_2	Special case variable [-]
Z	Section modulus [m ³]
F_f	Force at failure [N]
$M_{1,2,3,4}$	Material index [-]
σ	Stress [Pa]
σ_y	Yield strength [Pa]

Contents

List of Acronyms	ix
Nomenclature	xi
List of Figures	xix
List of Tables	xxi
1 Introduction	1
1.1 Background	1
1.2 Aim	2
1.2.1 Limitations	2
1.2.2 Specification of issue under investigation	3
2 Frame of reference	5
2.1 Savitsky	5
2.2 Foil & Wing theory	6
2.2.1 Section profile	6
2.2.2 Cavitation	7
2.2.3 Drag - Types & Effects	8
2.2.4 Lifting Line Theory	9
2.2.5 Lift Force, Drag Force & Pitching Moment	10
2.2.6 Planforms	11
3 Method	15
4 Development of hydrofoil concepts	19
4.1 Needs & Requirements	19
4.1.1 Stakeholder identification & needs	20
4.1.2 Hull resistance	21
4.1.3 Product requirement specification	24
4.2 Section profile evaluation	26
4.3 Concept generation	28
4.3.1 Function Tree	28
4.3.2 Internal & External Research	29
4.3.3 Internal Brainstorming	31
4.3.4 Generated Concepts	32

4.4	Concept Evaluation & Scoring	39
4.4.1	Calculations & Evaluation	39
4.4.2	Concept Scoring	46
4.5	Material and manufacturing	48
4.5.1	Design Requirements	48
4.5.2	Material Indices	49
4.5.3	Screening & Ranking	50
4.5.4	Candidate materials	51
4.5.5	Cost & Manufacturing processes	57
4.5.6	Conclusion of material & Environmental aspects	60
4.6	Further development of concepts	61
4.6.1	Second loop idea-generation and evaluation	61
4.6.2	Concept synthesis & Evaluation	63
4.6.3	Second Concept scoring	68
4.7	Validation of concepts	69
4.7.1	Requirement verification	70
4.7.2	Validation of hull efficiency	71
4.8	Ethics & Sustainability	73
5	Concept Catalogue	77
6	Conclusion	83
7	Discussion	85
7.1	Method, Results & Source of error	85
7.2	Future work and recommendations	86
	Bibliography	89
A	Appendix	I
A	Savitsky: Matlab Flowsharts	I
B	Savitsky hull resistance	II
C	Hull-Resistance	IV
D	Foil section - compare section profile	V
E	Requirement specification	VIII
F	Matrix of correlations between requirements and criterias	X
G	Subjective and objective values	XII
H	Pairwise comparison matrix	XII
I	Material index M1	XIII
J	Material index M2	XIII
K	Charts Material	XIV
L	Morphological matrix Single concept	XVI
M	Morphological matrix Odd dual concept	XVII
N	Morphological matrix Comes around concept	XVIII
O	Morphological matrix Odd Berit concept	XIX
P	Morphological matrix Telescopic concept	XX
Q	Manufacturing cost	XXI

R	FMECA	XXII
S	Second Subjective and Objective value matrix	XXVII
T	Second Pairwise comparison Matrix	XXVII
U	Concept validation - Behaviour of the foil	XXVIII
V	Concept validation - Behaviour of the hull	XXIX

List of Figures

2.1	Forces affecting the hull in the Savitsky method	5
2.2	Forces and angles, affecting and generated by the section profile	7
2.3	Example of different planform designs	11
3.1	Process of product development in the project	15
4.1	Forces affecting the hull in the Savitsky method, including forces from hydrofoil	22
4.2	Effect of affecting the hulls with an lift force generated by hydrofoils	24
4.3	NACA 4-digit section profiles investigated	26
4.4	Cavitation and pressure distribution in regard to the section profile	27
4.5	Coefficients calculated for all section profiles at a speed of 15kn and a chordlength of 0.3m	27
4.6	Function Tree of the product	29
4.7	The groups as a result of the brainstorming session, declaring the concluded groups	32
4.8	Visualisation of the principle concept <i>Single</i>	33
4.9	Visualisation of the principle concept <i>Decker</i>	34
4.10	Visualisation of the principle concept <i>Y-foil</i>	34
4.11	Visualisation of the principle concept <i>Behind</i>	35
4.12	Visualisation of the principle concept <i>Comes around</i>	36
4.13	Visualisation of the principle concept <i>Odd Plate</i>	37
4.14	Visualisation of the principle concept <i>Odd Dual</i>	38
4.15	Visualisation of the principle concept <i>Odd Berit</i>	39
4.16	L/D vs Lift force for the concept <i>Single</i> at viscous speed of 15kn	41
4.17	L/D vs Lift force for the concept <i>Decker</i> at viscous speed of 15kn	42
4.18	L/D vs Lift force for the concept <i>Odd plate</i> at viscous speed of 15kn	44
4.19	L/D vs Lift force on the <i>Odd Dual</i> for different viscous speeds	45
4.20	Evaluation of the principle concepts in the first iteration with a Kesselring matrix	46
4.21	Verification of the concept with the second Kesselring matrix	47
4.22	Set up and total deflection of first iteration	53
4.23	Total deflection of the foil with stainless steel and aluminium alloy	54
4.24	Set-up of the foil in thermoplastic	55
4.25	Stress and total deflection of the foil in reinforced POM-C	56
4.26	Cost for material and manufacturing processes	58
4.27	Cost for material and manufacturing processes	59

4.28	Part one of the Morphological Matrix	62
4.29	Part two of the Morphological Matrix	63
4.30	Visualisation of the principle concept <i>Telescopic</i>	64
4.31	Overview of the refined Morphological matrices	66
4.32	Evaluation of the refined concepts with a Kesselring matrix	69
4.33	Investigating the foil with different running conditions and Angle of Attack	72
4.34	The effect of utilising the developed foil on different hulls	73
A.1	Flowshart of the Savitsky Core Matlab script	I
A.2	Flow shart of the total Savitsky method Matlab script	II
A.3	Drag of hull vs Lift force generated by foil for the hull resistance investiga- tion, for all hulls	IV
A.4	Lambda value vs Lift force generated by foil for the hull resistance investi- gation, for all hulls	IV
A.5	Section profile comparison with chord length 0.2m and a speed of 10kn . .	V
A.6	Section profile comparison with chord length 0.2m and a speed of 15kn . .	V
A.7	Section profile comparison with chord length 0.2m and a speed of 20kn . .	VI
A.8	Section profile comparison with chord length 0.3m and a speed of 10kn . .	VI
A.9	Section profile comparison with chord length 0.3m and a speed of 15kn . .	VII
A.10	Section profile comparison with chord length 0.3m and a speed of 20kn . .	VII
A.11	First part of the Requirement specification	VIII
A.12	Second part of the Requirement specification	IX
A.13	First part of the Matrix	X
A.14	Second part of the Matrix	XI
A.15	Subjective and objective values of the criterias	XII
A.16	Pairwise comparison matrix for calculating the factor of weights	XII
A.17	Yield strength vs density	XIV
A.18	Yield strength vs density times price	XIV
A.19	Young's modulus vs density	XV
A.20	Young's modulus vs density times price	XV
A.21	Morphological matrix single concept	XVI
A.22	Morphological matrix Odd dual concept	XVII
A.23	Morphological matrix Comes around concept	XVIII
A.24	Morphological matrix Odd Berit concept	XIX
A.25	Morphological matrix Telescopic concept	XX
A.26	Manufacturing cost for each concept	XXI
A.27	FMECA on the concept Single	XXII
A.28	FMECA on the concept Odd dual	XXIII
A.29	FMECA on the concept Comes around	XXIV
A.30	FMECA on the concept Odd Berit	XXV
A.31	FMECA on the concept Telescopic	XXVI
A.32	Second Subjective and objective value matrix of the criteria	XXVII
A.33	Second Pairwise Comparison Matrix for calculating the factor of weights .	XXVII
A.34	Generated lift from foil at different running alternatives and all speeds . .	XXVIII
A.35	AoA of foil and hull for different running alternatives and all speeds . . .	XXVIII
A.36	Thrust reduction and lambda values for all hulls at all speeds	XXIX

List of Tables

4.1	Users, other stakeholders the respective actor for the semi-foil product . . .	20
4.2	Hull specification of investigated hulls	23
4.3	Most important requirements/desires from the requirement specification . .	25
4.4	Design requirements for the product	49
4.5	Material data from level 2 [35]	51
4.6	Material data from level 3 [35]	55
4.7	Material data for remaining materials from level 3 [35]	60
4.8	Manufacturing cost for each concept	65
4.9	Most critical failure modes	67
4.10	Fulfilment table of the most important requirements/desires	70
4.11	Foil properties for validation of beneficial aspects	71

1

Introduction

This report incorporates product development of conceptual hydrofoils on pod for electrical propelled low speed vessels, investigating the utilisation of hydrofoils to increase the user experience and the efficiency of propulsion, by affecting the hull with a lift force at stern without lifting the entire hull out of the water. The chapter Frame of reference, addresses the theoretical aspects utilised within the project, enabling the reader to acquire the knowledge necessary to comply with certain decisions and outcomes. The Method addresses the overall methodological approach used within the project, defining the process and the established methods. The Development of hydrofoil concepts includes the whole development process, including the initial and final investigations of hull resistance and customer needs, the extensive material research and evaluation, as well as comprehensive evaluation and assessment of the invented concepts. The Concept catalogue concludes the the outcome of the Development of hydrofoil concepts, presenting each concept and addressing its aspects on one page each. If the recipient is interested of the characteristics, qualitative, and quantitative evaluation regarding the principle concepts, should incorporate the sections Generated concepts 4.3.4, Calculations & Evaluation 4.4.1, Concept synthesis & Evaluation 4.6.2, Validation of hull efficiency 4.7.2, and Concept catalogue 5.

1.1 Background

Motorboats of today consume a tremendous amount of fuel impacting the environment negatively. As the focus on climate change and sustainability is rapidly increasing the boat-industry has to adapt, providing the market with more efficient and sustainable solutions [1]. The sustainability focus of today's society requires change in human behaviour and innovative solutions, adapting to the new circumstances and new laws generated, implying that the usage of boats will change. Developing products which entail comfortable, safe, and effortless boat travel and ownership, and decreasing the environmental impact will contribute to these aspects.

Volvo Penta is market-leading within propulsion systems for motorboats, pushing the technology forward [2]. Their existing product, the IPS-pod, is manufactured in bronze, equipped with engine power up to 1000hp, utilised on boats in the size range of 30-100+ feet, and focuses on speeds of +20kn. The pod has forward-facing, twin counter-rotating propellers, by rotating the pod, the direction of the boat can be changed. This entails a higher efficiency and top speed compared to inboard shafts. It is the most expensive system among Volvo Penta's product range, targeting the segments of leisure- and commercial marine [3]. The IPS-system was launched in 2005, since then few principle

propulsion changes have been performed regarding the product, implying that the product is designed due to the requirements and technical feasibility existing almost two decades ago, enabling possible improvements within the concept.

In the industry of boat building, manufacturers are developing more energy-efficient hulls, hybrid- and electrical propulsion systems, focusing on energy consumption and green energy sources, protecting the ocean life and decreasing the environmental impact [1]. Within the industry energy efficient hulls targeting the unconventional speed range of 10-20kn starts to emerge, due to the increased focus on energy efficiency these speeds are of interest as the necessary power demand could be decreased. Hydrofoils have in the past been utilised to lift hulls out of the water and decrease the required energy to propel the vessel. As the market start to focus on energy efficiency, hydrofoils has once again become a hot topic, enabling the energy consumption propelling the boat to be decreased [4].

1.2 Aim

This master thesis aims to develop conceptual hydrofoils implemented on the pod, generating a lift force at stern of the hull, investigating and concluding the beneficial aspects. Considering implementation of hydrofoils without lifting the entire hull out of the water, at a target speed of 15kn and endeavour to decreasing the hull resistance, to comply with the future sustainability focus. Further, incorporate enhancement of comfortable, safe, and effortless boat travel within the development, future and existing customer needs can be met. The development addresses considerations and investigations regarding the environmental impact and adequacy of possible materials and manufacturing methods. The outcome of the project is to deliver a concept catalogue containing extensive information, data, and considerations regarding four different concepts, with sufficient information to enable future projects to utilise the outcome.

1.2.1 Limitations

A numerous of issues is not investigated in this project. This is because the project had a time limitation of five months, and some of the issues have already been dealt with by other parties, implying the unnecessary of reproducing the answers. The issues not investigated / limitations during this project are as follows:

- The project does not consider internal combustion engines as a part of the propulsion system, implying exhaust gases and emissions of fossil fuel does not have to be taken into account.
- Issues regarding advanced fluid dynamics which require Computational Fluid Dynamics (CFD) software to be analysed, since it is too time-consuming for this project.
- Issues regarding advanced strength of material which require Finite Element Analysis (FEA) software to be analyzed, to assure the concept can handle stress/strain/-fatigue since this is too time-consuming for the project. Simpler cases have been executed but not to the full extent where all the specified areas are covered.

- Optimize or further investigate in-depth about energy-efficient boat hulls since this is out of the area of knowledge and would result in an additional research topic.
- Prototyping nor advanced physical designs, since the vast majority of time is spent on modelling and understanding the foils at low speeds.
- Hydrofoils dislocated from pod since these products already exist on the market and are well developed.
- Develop nor change interfaces between the hull/pod, and pod/propellers, since the hydrofoils on pod is to be used with the existing interfaces and propellers.
- Limitations regarding manufacturing cost, only calculations on simpler cases are conducted, no in depth-analysis, where the interface and system controls between the pod and foil are not accounted for. The latter are not developed in this project and the cost is not derived from information from the company but from a software.

1.2.2 Specification of issue under investigation

From the basis of the aim, issues could be specified for this project. These are the main questions investigated during the project and answered at the end of the project. The issues are as follows:

1. How can hydrofoils on the pod contribute to decreasing energy consumption of energy-efficient boat hulls in semi-displacement running conditions?
2. What material with an appropriate manufacturing method can be used for application in the ocean-environment, enabling the design and minimising the weight of the concept-sets?

2

Frame of reference

This chapter contains the overall theoretical references used within the project, accounting for the specific theories and equations. It facilitates the reader to acquire the knowledge and in-depth information necessary to comprehend the calculations and results throughout the project. Incorporating the theory of D. Savitsky [5] that is utilised to calculate the hull resistance, the theories of General Aviation Aircraft Design by S. Gudmundsson [6] and Principles of Yacht Design by L. Larsson et al. [7] to enable generic calculations of forces generated by the wing as well as the relation between aeroplane wings and hydrofoils.

2.1 Savitsky

The purpose of the Savitsky method is to calculate the resistance of prismatic hull shapes, enabling the required engine power of planing crafts to be approximated. The theory was used at the beginning and at the end of the project to determine the effects of affecting a hull with a lift force and to validate the results. Savitsky's method originated from Daniel Savitsky in 1964 and is based upon experimental and theoretical studies. The method uses the equilibrium of the hull, see equations 2.1, 2.2, 2.3, iterating/interpolating the values until momentum equilibrium is achieved. For remaining equations see Appendix B, for forces and moments acting on the hull, see Figure 2.1 [5].

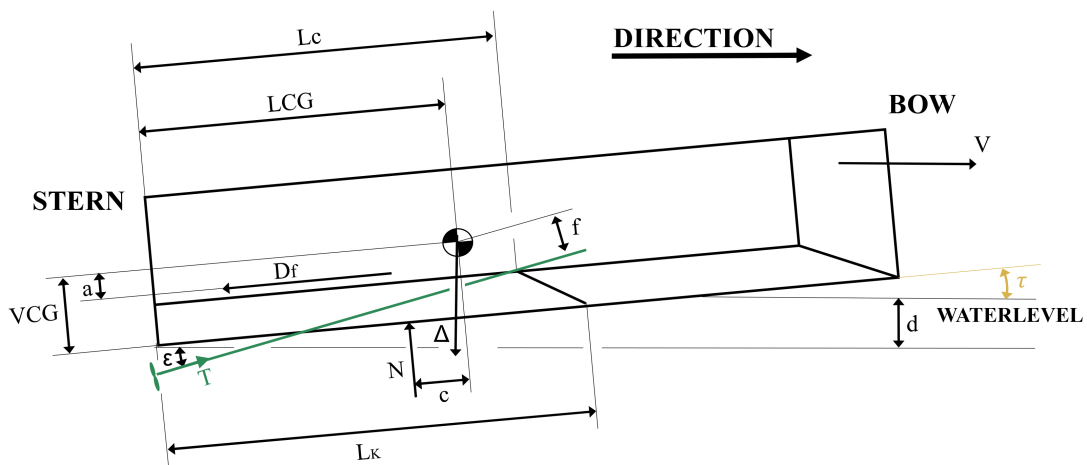

Figure 2.1: Forces affecting the hull in the Savitsky method

Vertical equilibrium:

$$\uparrow: \Delta_0 = N \cdot \cos(\tau) + T \sin(\tau + \epsilon) - D_f \cdot \sin(\tau) \quad (2.1)$$

Horizontal equilibrium:

$$\rightarrow: T \cdot \cos(\tau + \epsilon) = D_f \cdot \cos(\tau) + N \cdot \sin(\tau) \quad (2.2)$$

Pitching Moment:

$$\curvearrowright: N \cdot c + D_f \cdot a - T \cdot f = 0 \quad (2.3)$$

The method accounts for the angle of attack of the hull, centre of gravity, and the dimensions and loading of the hull itself. The theoretical approximations are valid for certain intervals of values, implying that $0.66 \leq C_v \leq 13$, $2^\circ \leq \tau \leq 15^\circ$, and $0 \leq \lambda \leq 4$ has to be fulfilled. The C_v is the speed coefficient, τ the angle of attack of the hull, and λ the mean wetted length-beam ratio [5].

2.2 Foil & Wing theory

This section incorporates theories and design aspects regarding wings, including the limits of cavitation, generic equations, and the definition of different planforms. The design aspects consider the applicability of different aerodynamic factors affecting the characteristic of the wing, and the relation between aerodynamic and hydrodynamic behaviour. It addresses the aspects to consider when translating the generated 2D information into 3D, enabling calculations for the entire hydrofoil to be conducted with generic equations.

2.2.1 Section profile

The theory regarding the section profile was used in the beginning of the project, to investigate the effect of changing the section profile and enable the determination of a section profile to be used in further development. A pressure field is induced when an object moves through a fluid, and the section profile bends the viscous flow near the upper surface, causing an acceleration of the viscous fluid towards the section profile. The pulling of the viscous fluid, also referred to as the Coanda effect, results in low pressure near the upper surface, resulting in a net force referred to as lift [8]. The section profile of a wing is designed to generate lift with as little drag as possible, where the lift is defined tangent to the trajectory and drag in opposite to the trajectory, see Figure 2.2. Forces and the pitching moments act at the centre of pressure of the section profile, commonly located $\approx Chordlength/4$ from the leading edge, the location depends on the pressure distribution and will because of that vary [6].

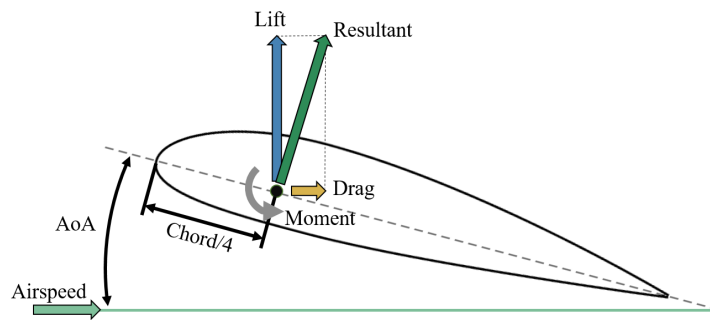

Figure 2.2: Forces and angles, affecting and generated by the section profile

There are extensive research and calculation conducted in regard to the design of the section profile, it is an advanced topic where the design is generated by changing the pressure distribution, and optimising the shape for the specific usage case. There are a comprehensive number of different definitions of the profile sections such as Boeing, Clark, Drela, Eppler, Fage & Collins, Gottingen, NACA, NASA, Selig, and Wortmann, to mention a few, each containing a vast number of specific profile sections designed for specific usage cases [9]. The section profile is designed to distribute the pressure and pressure differences to maximise the lift while minimising the drag, avoiding cavitation and stall during operation. Stall occurs when full separation of the flow at to top of the section profile occurs, at this point the lift decreases and the Angle of Attack (AoA) at which this effect occurs is called stall angle [6].

NACA definition

National Advisory Committee for Aeronautics (NACA) was founded 1915 in the United States of America, and is a part of the foundation of what later became NASA. Between the 1920s and 1930s NACA developed and thoroughly investigated a series of section profiles (airfoils) defined by 4 digits, representing the camber, centre of camber, and thickness. By this engineers could pick the airfoil that corresponded to the specific performance requirements [10]. This series is today called the NACA 4-digit, later NACA further developed the definition into NACA 5-digit, and the NACA 6-series, each inheriting a different definition of the shape [11].

2.2.2 Cavitation

Cavitation is a phenomenon that occurs when the pressure locally decreases to a point where the water starts to transform from solid form to gas form, creating bubbles which implode. This results in violent behaviour, vibrations, noise, and cavitation corrosion [12],[13], implying that cavitation is to be avoided and accounted for when developing hydrofoils. The cavitation number/parameter, see equation 2.4, is non-dimensional, where P_{ref} is the surrounding pressure, P_{vap} is the vapour pressure of the medium, ρ the density of the medium and V_{ref} the free-flow speed of the medium [13].

$$\sigma = \frac{P_{ref} - P_{vap}}{\frac{1}{2}\rho V_{ref}^2} \quad (2.4)$$

When the minimum pressure coefficient around the foil exceeds the cavitation number, cavitation will occur. Keeping the absolute value of the lowest pressure coefficient below the cavitation number prevents this phenomenon to appear [13], see equation 2.5.

$$\sigma \leq |\min(C_p)| \quad (2.5)$$

2.2.3 Drag - Types & Effects

Since the total drag includes different components it is important to understand where they originate to enable calculations. Some of the components are generated by 2D CFD and others by generic equations, see Section 2.2.4, and are used to approximate the drag of the hydrofoil in the project. When considering the lift and drag on both the section profile of the hydrofoil, 2D, and the entire hydrofoil, 3D, classical wing theory for aerodynamics can be used. To utilise these theories the relevant Reynolds number is to be used [14], [15]. The drag can be divided into profile and induced drag where the former includes, form/pressure, skin friction and miscellaneous drag. The total drag coefficient, C_D can be expressed by the following equation 2.6 [6]:

$$C_D = C_{D0} + C_{Df} + C_{Di} + C_{Dmisc} \quad (2.6)$$

Where C_{D0} is the pressure drag coefficient, C_{Df} is the skin friction drag coefficient, C_{Di} is the induced drag coefficient and the C_{Dmisc} is the miscellaneous drag coefficient.

Profile drag

The profile drag is usually associated with the section profile of the wing [16], and is as mentioned divided into several areas, as form/pressure drag, skin friction drag and interference drag.

Form/pressure drag: The form/pressure drag corresponds to the form of the profile in 2D. When a fluid flows over a body it will cause a high pressure and a low-pressure region. The sum of the distributed pressure over a section profiles surface will generate the pressure drag, and components crucial for the drag are the ones parallel to the flow. If the AoA is highly increased or decreased the pressure drag will increase, due to the expansion of the separation region. [6].

Skin friction drag: Determining the skin friction drag is challenging since it depends on several aspects, such as the surface roughness of the foil, the wetted surface area, and the fluid's viscosity. The transition zone of the flow, when the flow changeover from laminar to the turbulent boundary layer, plays a role in how small/large the skin friction drag becomes. To create as much of a realistic friction drag as possible, the assumption is that there always is a mixed boundary layer, when both laminar and turbulent flows occur on the foil section. The shape will be of importance when it comes to where the transitions occur. There will be some laminar flow on the leading edge, and somewhere over the foil the transition occurs depending on how and where the thickest part of the section profile is and the AoA the section profile is operated at [6].

Miscellaneous - Interference drag: One of the miscellaneous drag is the interference drag which is related to effects generated by two bodies. The total drag of two separated bodies will be lower than if they are close or attached. If the bodies are placed side-by-side, one in front of the other or attached it will cause interference drag. If a wing and a body are attached the interference drag can correlate to both the boundary layer of the two bodies, the pressure losses and when the lift distribution is changed. To minimise the interference, drag design features can be added as fillets or fairings which creates a transition between the two bodies [17].

Induced drag

When having a finite wing, overroll of the high-pressure air from underneath of the wing, at the sides, up to the lower pressure on top will occur. This will result in vortices, which can create a downwash, implying the fluid moves downwards behind the wing. The overroll will lead to formation drag, or induced drag which will decrease the overall lift resulting in an extra angle of attack of the wing to achieve the same lift as with an airfoil [6]. To calculate the induced drag, see Section Lifting Line Theory 2.2.4.

2.2.4 Lifting Line Theory

To enable approximations of the generated lift of a hydrofoil and enable the calculations to be conducted with generic equations, the theories of the lifting line were used in the project. Result obtained from 2D cases of a section profile does only reply for wings with an infinite wingspan, as the vortices generated and the non-uniform distribution of lift is not into taken account. To account for the effects of a wing with finite span different theories can be applied. One theory is the Lifting-Line theory by Prandtl and Lanchester, which is based on numerous approximations and is one of the theories. [18]. With this theory, the lift distribution over the span of the wing can be established together with the induced drag, total lift, and downwash. The lifting line theory takes into account wings that have different taper ratios (different cord lengths along the wing) and wings with an elliptical planform. An elliptic wing is a wing which gives a constant lift coefficient distribution over the entire wing, and the planform other planforms usually are compared to. The aspect ratio of the wing should not be smaller than 4 for the results to be dependable [6].

The Lifting Line theory is based on a full wing without a body, and measures can be taken to account for the body between the wings. One is to remove the body from the calculations and only account for the exposed wing. The other way is to assume that the wing is attached to a wall, removing the body in between [6]. To calculate the lift coefficient for the wing the following equation is used, where C_{L2D} is the lift coefficient in 2D for an section profile, AR is the aspect ratio, and α is the angle of attack, see equation 2.7 [7].

$$C_L = \frac{C_{L2D}}{1 + \frac{2}{AR}} \alpha \quad (2.7)$$

Elliptical Wing

There are two special cases to which the Lifting Line theory can be applied, the first one is for an elliptic planform. This wing shape, elliptical wing planform, is useful within the aircraft design and accounts for a lift force distribution which is elliptic over the wing. For an elliptical wing, the aspect ratio is defined as the one in equation 2.8, where b is the span width. The induced drag coefficient, C_{Di} can be calculated with the lift coefficient, C_L over the wing, where C_r is the root cord length, see equation 2.9 [6], [7].

$$AR = \frac{4b}{\pi C_r} \quad (2.8)$$

$$C_{Di} = \frac{C_L^2}{\pi AR} \quad (2.9)$$

Arbitrary Wing

For wings that do not have an elliptical planform, certain considerations need to be taken. To apply the lifting line theory on arbitrary wings Oswald's Span Efficiency factor is used when calculating the induced drag over the wing. There are plentiful ways to calculate the factor, but the value usually lies between 0.7-0.9. The equations for the aspect ratio will be different when not using an elliptical wing. For straight and swept-back constant-chord wings the AR will be as equation 2.10, and for tapered wings as equation 2.11. The induced drag coefficient, C_{Di} , will instead be calculated as equation 2.12, with AR-dependent on the type of the shape of the wing [6].

$$AR = \frac{b}{C_r} \quad (2.10)$$

$$AR = \frac{2b}{C_r + C_t} \quad (2.11)$$

$$C_{Di} = \frac{C_L^2}{\pi AR e} \quad (2.12)$$

2.2.5 Lift Force, Drag Force & Pitching Moment

Once the different lift and drag coefficients, in both 2D and 3D, have been determined, the lift and drag force can be calculated on the hydrofoil, together with the density of the fluid ρ , the velocity of the fluid V , the area of the hydrofoil S , see equation 2.14 and 2.13. To calculate the pitching moment, the chord length c together with the pitching moment coefficient C_M is needed, see equation 2.15 [6].

$$F_D = \frac{1}{2} \rho V^2 S C_D \quad (2.13)$$

$$F_L = \frac{1}{2}\rho V^2 S C_L \quad (2.14)$$

$$M = \frac{1}{2}\rho V^2 S c C_M \quad (2.15)$$

The pitching moment in 2D, is the the moment around an predetermined point along the section profile, generated by the indifference in pressure distribution. The moment around the predetermined point will by that vary as the AoA of the hydrofoil is changed, see Section 2.2.1. The pitching moment in 3D, see equation 2.15 is valid for the planform Constan-chord, as the pitching moment for other planforms has to be integrated along the span width and is not addressed in this project.

2.2.6 Planforms

Theories regarding planforms are to increase the knowledge regarding the differences and the opportunities, of utilising various planforms in the design during the project. The definition of a planform is the design of the wing seen from above and can be characterised with different designs, see figure 2.3, further in this section categories of planforms and their characteristics will be addressed.

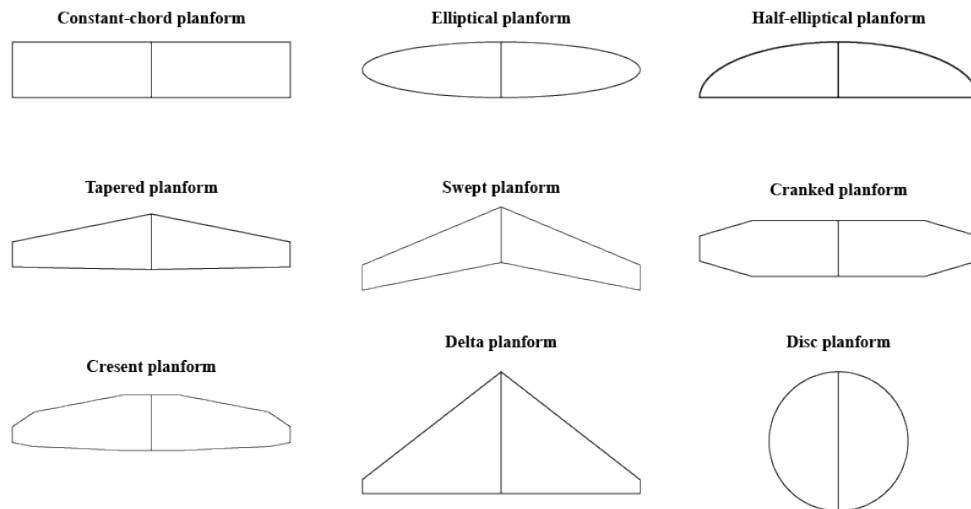

Figure 2.3: Example of different planform designs

Constant-chord ("Hershey-bar") planform

The constant-chord planform is the simplest of all planform with a rectangular planform. This type of wing is widely used for small as well as large aeroplanes and the constant profile enables the manufacturing to be simplified. The beneficial aspect of utilising this planform is the beneficial stall progression, as the lifting line at the tip is reduced, the stall starts from the root and progressively propagates along the wing to the tip. Although the planform is inefficient when it comes to generated drag and lift, that is one reason the planform should never be used for sailplanes and long-range aeroplanes [6].

Elliptical planform

The Elliptical planform has the most efficient lift distribution when it comes to induced drag. The planform can be configured as a pure ellipse but also with a straight leading or trailing edge as a half ellipse. The configuration changes do not lead to any indifference in the lifting line, although the sharp tip of the half elliptical shape introduces important viscous effects at higher AoA which has to be considered. Further, the uniform section lift entails the wing to stall at once, implying difficulties at low-speed or high AoA operations [6].

Tapered Planforms

Tapered planforms are a commonly used wing planform as it provides better efficiency than Constant-chord planforms and still being easier to manufacture than elliptical wings. The tapered planform can be configured in many alternatives where there are three main areas, Straight tapered, Straight leading or trailing edge, as well as Compound tapered planform [6]. Designing a tapered planform the taper ratio between the root and tip chord has to be considered, by using the correct taper ratio an elliptical lifting line can almost be achieved. The taper ratio for a tapered planform without any sweep back should be $\approx 45\%$, the more sweep back the lower the taper ratio becomes [7].

The taper planform compromises the stall characteristics implying the the necessity of an aerodynamically or geometrical wing wash-out, alternatively altering the profile section entailing the root to stall before the tip. A straight leading or trailing edge can be utilised to compensate for an unexpected centre of gravity, although the design entails challenges for single-piece spars in manufacturing. The compound tapered planform decreases the efficiency of the planform and has mainly been used for visibility purposes [6].

Swept planforms

Sweep back planforms are mainly used on aircraft operating at high speeds, delaying the occurrence of shockwaves to higher Mach numbers and utilising the stabilisation surfaces of the planform. The Swept planform can be defined as aft- as well as forward-swept, where the utilisation of the forward-sweep planforms increases the risk of fluttering and aeroelastic effects, requiring reinforcements of the wings to minimise the deflection. The aft-swept planform has a tendency to reduce the AoA at the tip of the wing due to aeroelastic effects as AoA of the wing increases, moving the centre of lift forward [6]. Utilising swept wing one needs to consider the taper ratio, the efficient ratio decreases as the wing is swept backwards and increases if swept forward [7].

Cranked planforms

Cranked planforms are defined as any wing that has a break in the leading or trailing edge, implying that the definition includes a large variety of planforms. A subcategory to this is the semi-tapered planform, characterised by its aileron effectiveness and efficiency compared to the Hershey-bar planform, increasing the section lift coefficient towards the tip of the wing. The Crescent planform is sparingly used within the aircraft industry, the planform allows a thick profile section at the root without introducing shockwaves at

high speeds. The planform contributed to improved aileron control as well as reducing the tendency of a tip stall. Further, the Schuemann planform is a popular planform for sailplanes, due to its reduction of lift-induced drag. The planform is not unlikely the elliptical planform, inheriting the potential risk of an early wing tip stall caused by the sharp outboard taper ratio. Highly swept planforms can counteract this effect by locating the tip vortices at the right position. Sailplane wings will due to aeroelastic effects flex substantially, unloading the wing tip and delaying stall, implying good stall characteristics. Lower aspect ratio wings are expected to generate decisive wing wash-out if the wingtip is not swept enough [6].

Delta & other planforms

Delta and double-delta planform are mainly used for supersonic aircraft, stalling at very high angles of attack with a poor efficiency ratio. Although the planform is beneficial for supersonic aircraft demanding high movability and where the energy consumption is of no issue. Further, there are a group of exotic planforms, including Disc- or Circular-shaped planform, that has been used in a secret project without any success. The planform is very inefficient and inherits an unstable behaviour, it has mainly been utilised for radar-disc applications [6].

3

Method

This chapter deals with the overall product development method and process practised in this project *Hydrofoils on pod for electrical propelled low speed vessels*. The project applies established product development methods adapted to benefit the process of the project. Main product development methods utilised in the project are the Set-based concurrent engineering by Toyota [19],[20],[21], and the Product design and development by Ulrich and Eppinger [22].

Utilising set-based concurrent engineering in combination with the detailed tools of the Product design and development, the design-space can be successively narrowed throughout the project, focusing on discarding solutions and working with principle concepts, instead of investigating all specific possible concepts. The following process seen in Figure 3.1 was used in the project, considering certain aspects at an early stage of the project, acquiring knowledge in regard to the constraints and decreasing the design-space, permitting critical decisions to be conducted in a late state of the project in compliance with lean-product development and set-based concurrent engineering [20],[23].

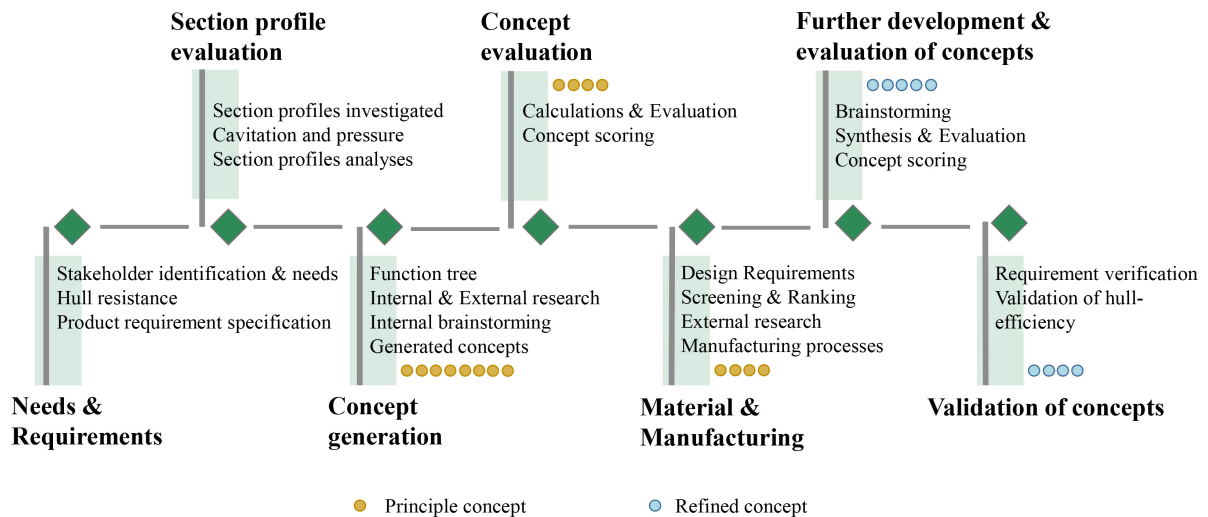

Figure 3.1: Process of product development in the project

The process generates principle concepts, based upon the main function, evaluating these as sets to narrow the design-space. Investigating the material & manufacturing aspects of the principle concepts, enabling the design-space to be narrowed before further development of the principle concepts. Validation of the beneficial aspects and requirement

justification ensures the outcome complies with the needs, requirements, and expectations.

During the project and within the external research, knowledge has been acquired through literature searching on the known platforms Google scholar, Research gate and Chalmers Library, and Google search, gathering information regarding the specific fields. Further, continuously meetings have been conducted with domain experts, concluding knowledge through a series of deep discussions, facilitating the design-space to be narrowed and decisions being conducted upon a sufficient foundation of knowledge.

Needs & Requirements. Stakeholder needs were produced in conjunction with the company, utilising the information, knowledge, and experience already existing. Considering the different types of needs [24], and utilising the Kano-model [25], carefully and iterative elaborate the stakeholders' needs early in the process. The hull's needs and the effect of affecting the hull with a lift force, were conducted with the established Savitsky method, approximating the hull resistance with generic equations [5]. Concluding the requirements considering the elements of the Pugh Design Core [26], converting the needs requirements [22], and concluding requirements regarding regulations and laws affecting the product. Iterative elaborating and updating the requirement specification in collaboration with the company throughout the project.

Foil section evaluation. The evaluation was conducted early in the project, to establish knowledge and conclude a specific section profile to be utilised throughout the development process. The method was to select numerous section profiles of a wide variety of the most common ones, to minimise the variables throughout the project, conducting an early evaluation of sub-solutions accordingly to Lean-development. The evaluation was performed with the open software Xfoil [27] together with the programming language MATLAB dismiss section profiles not fulfilling the produced requirements [28].

Concept generation. The main function of the product was established, together with its corresponding sub-functions, from the functional requirements and the functional analysis of existing products [29]. An external and internal research was implemented to find these functions, to gain inspiration for possible solutions and a perspective of existing products on the market today, enabling for a brainstorming. The brainstorming was conducted on the main function with the result of principal concepts [26].

Concept evaluation. Concluding and evaluating the generated principle concepts were conducted within different steps. First, the principle concepts were analysed together with experts at the company, enabling an understanding regarding the capacity of the design-space. Second, the principle concepts were evaluated with quantitative and qualitative methods. The Quantitative method utilises numerical calculations to assess the capability, and the qualitative method utilises the knowledge within the company the assess and evaluate the pros and cons. Third, the principle concepts were screened with a Kesselring matrix evaluating each principle concept against criteria, carefully connected to the requirement specification

[30],[31]. The criteria were weighted systematically with a Pairwise Comparison Matrix [32].

Material & Manufacturing. The material and manufacturing were conducted, to investigate the suitability of different materials and manufacturing methods, narrowing the design-space for further development. The analyses and material selection were conducted according to the method of Ashby [33], and the manufacturing methods according to Swift & Booker [34], both being reputable and systematical methods. Throughout the process, data from the software ANSYS Granta Selector [35] and the external research was utilised. A structural analysis was conducted to predict the amount of material needed for the concepts with the software ANSYS Mechanical [36], to be able to calculate the cost for the chosen material and manufacturing processes.

Further development of concepts. Further development of the principle concepts was conducted with the sub-functions as a primary target, focusing on exploring the whole reduced design-space. By conducting a second brainstorming upon the sub-functions, concluding and evaluating the result, synthesising and refining the principle concepts was viable. Further, complying with the Lean development and Set-based concurrent engineering [20], [23], decreasing the design-space of each principle concept by evaluating the sub-solution, concluding their feasibility for the specific composition. The principle concepts were then evaluated with a Kesselring matrix [30], grading the criteria with a Pairwise Comparison Matrix [32], and ensuring the affiliation between criteria and requirement specification.

Validation of concepts. Requirement verification was conducted to compare the refined concepts towards the requirement specification, concluding the fulfilment of specific requirements and enabling an understanding of what has to be investigated and considered in future development. The validation concludes calculations of the beneficial aspects and efficiency of the hull, by implementing the developed principle concepts into the Savitsky method [5], validating and ensuring the performance of the product implemented on different hulls.

4

Development of hydrofoil concepts

This chapter regards the development of the hydrofoil concepts including eight different sections. The development starts by investigating the needs and requirements of the product, examining the effect of affecting a hull with a lift-force from a hydrofoil, and concluding the requirement specification. The evaluation of section profiles of the hydrofoil considered the effect of changing the parameters of the NACA 4-digit definition, deciding upon one section profile for the hydrofoil calculations, narrowing the design-space.

The core of the development process consists of three main steps, each focusing on decreasing the design-space and gathering knowledge. The first was to generate ideas upon the main function, concluding principle concepts and evaluating them. Thereafter material and manufacturing processes were investigated to gain knowledge and conclude what appropriate materials and manufacturing methods could be utilised to enable the designs. The last step of the core development phases consists of further development of the concepts, utilising the sub-functions to generate sub-solutions, ensuring the design-space is carefully investigated, enabling refinement and development of concepts.

The refined concepts were evaluated and the remaining were validated by analysing the requirements and desires in the requirement specification, and by implementing the forces generated by the foils into the Savitsky method ensuring the performance of the concepts. Finally, the ethics and sustainability regarding the concepts are considered, and outcome of the project is discussed. The word *foil* is used throughout the report instead of the word *hydrofoil* to make it easier for the reader to read and follow.

Disclaimer: The information and data in the development are generated by the project, implying that the Requirement specification has been developed in consultation with the company, but does not originates from their data, therefore the company does not take any responsibility for the result.

4.1 Needs & Requirements

This section investigates the requirements and needs correlated to the product, concluding the requirement specification, to systematically ensure that the development complies with these. Identifying the stakeholders that are affecting the product or are affected by the product during its life cycle, and concluding their needs and requirements. The effect of affecting a hull with a lift force generated by a foil is investigated to enable the requirement of necessary lift force to be determined. The product specification concludes

the requirements in relation to the product.

4.1.1 Stakeholder identification & needs

The stakeholder and other actors were identified at the beginning of the project to establish who is affecting or affected by the product, through interviews with Volvo Penta, to identify the needs. Since the aim is to develop foils on pods, the users and stakeholders will not deviate considerably for this product compared to the products sold by the company today. The customer needs regarding the end customer which are the boat owner/operator and the fellow travellers, both the customer and company's needs were derived and compiled from discussions with experts at the company.

The primary user of the product is the boat owner/operator propelling the boat together with the fellow travellers on the boat, whilst the secondary users are the company, personnel who stores the boat whilst not used, and maintenance and service personnel, see Table 4.1. The main customer of the product is the boat builder, which sells the product to the end customer, the expected boat owner. Volvo Penta is the primary stakeholder, secondary stakeholders are the suppliers providing the company with parts for the production and maintenance of the product. Additionally, regarding regulation the European commission, the Det Norske Veritas (DNV) and International Maritime Organisation (IMO) are secondary stakeholders affecting the requirements of the product.

Table 4.1: Users, other stakeholders the respective actor for the semi-foil product

Users & Other Stakeholders	Actor
Primary users	Boat owner/operator Fellow boat travellers
Secondary users	Volvo Penta Storage owner Maintenance and service personnel
Primary stakeholder	Volvo Penta
Customer	Boat builder Commercial companies Boat owner/operator Expected boat owner
Supplier	Manufacturers of Volvo Penta designed parts Suppliers of standard parts
Regulatory agencies/Society	European Commission DNV IMO

The customers' basic needs and expectations of the product during operation comply with Volvo Penta's needs. The product is to be used in a submerged environment and the boat is stored on land when it undergoes service and is not in operation, implying a range of different temperatures and external stresses which the product must be able to withstand.

The product should not increase the complexity of operation, avoiding the necessity of education to enable the operator to manoeuvre the boat, the maintenance and cost, which would decrease the primary user satisfaction. The boat is to be propelled effortlessly and comfortably, without any extra annoyance regarding for instance clamorous noise, both above and below water, or increasing additional aspects to consider during operation. One explicit need is the ease of use, by owning and operating the boat with a minimum need for maintenance, such as removal of biofouling, removing debris, and no additional repairs regarding maintenance of corroded parts and leakage.

When observing the customer propelling a semi-displacement boat at increased speeds, depending on the type of boat, the field of vision is decreased since the angle of attack of the boat is increased and the bow tilts upwards. A need for the customer is visualisation, to have the eyes on the horizon at all times, ensuring a safe and pleasant ride without any disturbances. When the boat's pitch increases, the customer will encounter problems and difficulties regarding the ease of moving around on the boat in a safe manner. In addition to increased speed changing the pitch, it can be altered by the waves and the wind, which in turn have an effect on the roll of the boat. Further, the pitch and roll can be altered by uneven weight distribution, which is a repeated encounter due to deadweight and fellow travellers relocating their positions. This correlates to the need of feeling secure whilst operating the boat, the boat should not infuse an unsafe feeling while being operated.

Increasing the pitch of the boat in the speed range of 10 – 20kn increases the displacement of the water and so the drag acting on the hull. This correlates to the efficiency of operating the boat. One explicit need is to minimise the need for charging, preferably not to charge at all during a day trip. Many times the customer wants to visit an island and not all of them contain charging stations. This resembles the need for an extended range of one charge, by increasing the efficiency of the hull, and decreasing the total cost of the operation, as the need for decreasing the environmental impact.

The company's needs are to provide a longer range together with increased efficiency along with providing innovation to maintain their market position. Since new requirements emerge regarding environmental aspects, decreasing the usage of material is an uprising need, along with reduction of the weight of the boat since increased displacement correlates to increased energy consumption. Today, the company has the need to maintain and enhance the user experience for the customer, along with the philosophy of Easy Boating [37]. Easy Boating is to supply products which allow whoever to propel the boat regardless of experience and training, complying with the idea of enhancing the user-friendliness. Easy Boating incorporates simplicity of ownership, complying with the need to decrease the risk of failure and increased serviceability.

4.1.2 Hull resistance

Investigating and understanding the resistance and behaviour of the hull, and the changes of it when affected by forces generated by a foil, was conducted by utilising the Savitsky method and its equilibrium equations, see Section 2.1. There are other generic approximation methods addressing different approaches of calculating the resistance of hulls, such as

Van Oortmerssen, Holtrop, Holtrop & Mennen, focusing on the displacements and cargo vessel category. Savitsky utilises equilibrium equations, enabling external forces to be added to the equations.

A hydrofoil generates a drag and lift force which affects the hull, these forces can be added to the equilibrium, see Figure 4.1. The method of adding external forces to the equilibrium has been implemented when investigating interceptors for boat hulls with great success [38]. The accuracy of the Savitsky method has been extensively investigated and compared to both CFD models and physical models, the result indicates that the Savitsky method replicated the behaviour of the physical model from speeds of 12 knots, although the values are slightly offset [38], implying the validity of utilising the method comparing the changes when adding external forces focusing on the speed of 15 knots.

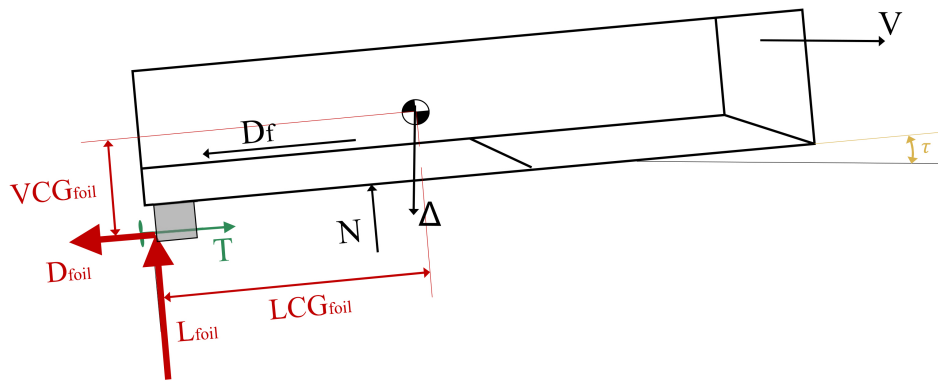

Figure 4.1: Forces affecting the hull in the Savitsky method, including forces from hydrofoil

Calculation of the extended equilibrium equations 4.1, 4.2, 4.3, and the equations of the Savitsky method, see Appendix B, was calculated with the software Matlab, as the equations have to be iterated in different steps to find the values generating moment equilibrium of the hull, for the structure of code see flowcharts in Appendix A.

Equilibrium:

$$\uparrow: \Delta_0 = N \cdot \cos(\tau) + T \sin(\tau + \epsilon) - D_f \cdot \sin(\tau) - D_{foil} \cdot \sin(\tau) + L_{foil} \cdot \cos(\tau) \quad (4.1)$$

$$\rightarrow: T \cdot \cos(\tau + \epsilon) = D_f \cdot \cos(\tau) + N \cdot \sin(\tau) + D_{foil} \cdot \cos(\tau) + L_{foil} \cdot \sin(\tau) \quad (4.2)$$

$$\curvearrowright: N \cdot c + D_f \cdot a - T \cdot f + L_{foil} \cdot LCG_{foil} + D_{foil} \cdot VCG_{foil} = 0 \quad (4.3)$$

The structure of the developed script uses the data of the boat and foil, calculating the resistance and the angle of attack of the hull for every speed desired that fulfils the requirements of the Savitsky method, see Section 2.1. The script was validated by running the same hull specifications used by others, and comparing the result to ensure validity. The articles used for result comparison are the Savitsky method [5] as well as an investigation of electrical boats [39].

Hull Specifications

To gain a sufficient understanding of the hull when affected by a foil, a group of different hulls was investigated, see Table 4.2. The values of the hulls were synthesised in collaboration with the company experts that possess great knowledge within hull properties and user groups.

Table 4.2: Hull specification of investigated hulls

Boat name	LWL [m]	BWL [m]	Deadrise [°]	Disp. [kg]	LCG [m]	VCG [m]
Ideal boat	11.0	3.6	10	10500	5.5	1.2
Small Flat	8.5	3.0	5	8000	3.5	0.9
Small Steep	8.5	3.0	15	8000	3.5	0.9
Large Flat	15.0	4.5	5	16000	7.0	1.5
Large Steep	15.0	4.5	15	16000	6.0	1.5
Speed Boat	15.0	4.0	24	16000	4.5	1.2

The group contains six different hulls that range from 8.5 – 15m length, displacement 8000 – 16000kg, and a deadrise of 5 – 24°, accounting for the range of hulls of interest. A deadrise of 5 degrees for the Small Flat and Large Flat boat implies a hull with less planing threshold than the Small Steep and Large Steep boat that has a deadrise of 15 degrees. The Small Steep and Large Steep boat, accounts for typical parameters utilised for today’s planing hulls at a speed of 25-35kn, characterised by their ability to withstand rough pounding while maintaining a high speed in rough seas. Increased deadrise of the hull at the speed of 15kn, increases the hull’s ability to handle rough sea, the drag of the hull, and the pitch angle, implying a trade-off regarding drag of the hull, seaworthiness, safety, and field of vision when designing the hull. Further, the Ideal boat is a compromise of the parameters in the specification, complying with a realistic design of a hull developed for the speed of 15kn. The Speed Boat is an extreme case regarding high deadrise angle and stern heavy design, parameters normally utilised for very fast hulls operated in rough seas.

Result of hydrofoil

Performing the calculations with the developed mathematical model for each hull specification at a speed of 15kn, varying the lift force generated by the hydrofoil, generates the result seen in Figure 4.2, and Appendix C. The lift force generated by the hydrofoil was increased incrementally to analyse the effect on the hull, although the drag induced by the hydrofoil is not included in the drag of the hull, implying that the calculations only consider the decrease of the hull and not the whole system. The beneficial aspects and decrease of the drag for the whole system are considered and calculated for the developed concepts in section 4.7.2. The calculations aim to find the lift force acquired to efficiently decrease the resistance of the hull, obtaining the needs of the product.

4. Development of hydrofoil concepts

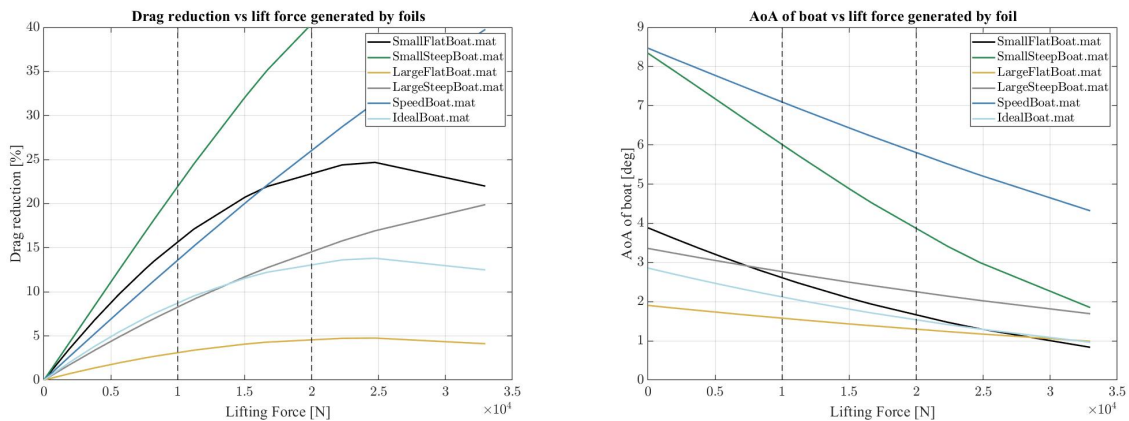

(a) Drag reduction of hull when affected by (b) Angle of attack of the hull when affected by a liftforce

Figure 4.2: Effect of affecting the hulls with an lift force generated by hydrofoils

As seen in figure 4.2a the drag reduction of the hull decreases as the lift force generated by the hydrofoil increases. It is clear that large hulls with low deadrise angles are hard to affect, as the size of the hull decreases and the deadrise increases, the hull becomes easier to affect. Further, the effect of increasing the lift generated by the foil decreases surpassing $\approx 20000N$. In figure 4.2b it is illustrated how the Angle of Attack (AoA) of the hull decreases as the lift force increases, implying a more pleasant experience for the user. Due to these results, a benefit and stagnation were seen in the span of $10000 - 20000N$ of lift generated by the foil, decreasing the hull resistance for almost every hull with at least 10%, and the AoA with at least 1° . The development will aim at a continuously lift force of $15000N$ at 15kn, divided between two pods implies $7500N$ for each pod.

4.1.3 Product requirement specification

A requirement specification was created at the start of the project and revised during the project. It is conducted to be able to utilise all information affecting the development of the product and capture the intention, linking the customer and company needs. The requirement list is divided into 14 categories, where the most comprehensive are the *performance* and *material*, along with requirements and desires regarding *environment*, *safety* and *cost*. The requirements were developed in consultation with Volvo Penta, with Volvo Standards and classifications, and Pugh Design Core [40], and divided into functional requirements (denoted F) and non-functional requirements (denoted NF) where the most important requirements and desires are listed in the Table 4.3. The rest of the requirement specifications can be seen in Appendix E. The subjective values in the requirement specification are derived from calculations during the project.

Table 4.3: Most important requirements/desires from the requirement specification

No.	R/D F/NF	Requirement	Unit	Spec.	Justification
1.3	R. F	Foil should break before pod	Binary	Pass/Fail	P. stakeholder
1.5	D. F	Angle of Attack of foils should be actively adjustable during operation	Binary	Pass/Fail	P. user
1.6	R. F	Must not generate cavitation	Binary	Pass/Fail	P. user
1.8	R. F	Must generate lift	[N]	7500	P. Stakeholder
1.9	R. F	Must generate inverted lift	[N]	2000	P. stakeholder
1.10	R. F	Must have a lift/drag ratio at design speed	ratio	8	P. stakeholder
1.11	D. F	Should have a lift/drag ratio at design speed	ratio	>15	P. stakeholder
1.16	D. F	Should increase the boats energy efficiency (compared to same solution without foils)	[%]	>10	P. user/Customer
1.17	D. F	Should handle rolling motions of hull (in 2-4 pod installations)	Binary	Pass/Fail	P. user/Customer
1.18	R. NF	The product must be designed for an ideal speed of	kn	15	P. user
1.24	R. F	Must prevent entanglement of foreign objects	Binary	Pass/Fail	P. user/S. user
2.1	R. NF	Pod+foils must have a decreased weight in regard to the initial design of pod	%	>15	P. user/stakeholder
2.3	R. F	Must withstand loads applied to it during operation	Binary	Pass/Fail	P. stakeholder
2.5	R. NF	Must handle a storage temperature	Degrees	-35<X<80	P. stakeholder/S. user
2.7	R. NF	Must be able to handle salt water	Binary	Pass/Fail	P. stakeholder
2.8	R. NF	Must be able to handle UV radiation	Binary	Pass/Fail	P. stakeholder
2.9	R. NF	Must withstand corrosion	Binary	Pass/Fail	P. stakeholder/S. user
2.10	R. NF	Surface layer must be tough to withstand intensive cleaning and chemicals	Binary & pH	Pass/Fail & 0<X<13	P. user/S. user
5.1	R. NF	Must not use material which is included in the Volvo Top Critical Materials list	Binary	Pass/Fail	STD 100-0005
14.1	R. NF	Must not cost more than a certain amount to produce the foils	SEK	5000	P. stakeholder/Customer

The functional requirement mainly originates from the *performance* category in the requirement specifications. The functional requirements mostly regarding how to generate and control lift, and the efficiency of the product since this is part of the main function of the product, see Section 4.3.1. Moreover, they regard safety aspects such as that the hull is to be intact if there is an impact. Numerous non-functional requirements include constraints regarding material, such as must handle salt water, ultraviolet light, certain storage and operation temperatures, but also cost aspects, such as the foil must not add any extra service cost and limitations regarding cost to produce the foils.

To be able to produce the product certain considerations regarding material, chemicals and noise need to be taken into account, which a few non-functional requirements regard. Volvo Groups standard STD 100-0005 lists materials that are derived from EU's List of critical Raw Material [41], and should be avoided if possible. Some of the materials are on the list due to their carbon footprint but can be reduced if measures are taken. Further, consideration regarding chemicals needs to be done, both due to the standard STD 100-0002 [42], which declares which chemicals substances shall not exist in chemical products or processes, but also the restrictions of the STD 100-0005 standard.

Regarding underwater noise, the regulations are few, but there are some guidelines and optional classifications on the market to follow, with respect to vessels and commercial ships. The SILENT-E class notation from the DNV [43], and the MEPC.1/Circ.833 guidelines from the IMO [44] to reduce underwater noise have requirements to satisfy and aspects to consider. Since the noise affects the marine life negative [45], there is nothing saying that the guidelines, classifications and regulations today will result in more regulated restrictions in the future, taking this matter seriously when designing the product

and therefore including requirements regarding these aspects.

4.2 Section profile evaluation

The project aims to investigate the broad variety of foils and their characteristics, implying that the section profile of the foil will not be optimised. Although the variety and different characteristics achieved by changes in the section profile have to be investigated, understanding the changes of behaviour as the section profile changes. This was conducted by investigating the NACA 4-digit as it is a well know and extensively investigated definition, see Section 2.2.1. To investigate the characteristics of the section profile, the pressure distribution has to be generated for the specific usage case, to do so an open-source 2D Computer Fluid Dynamics (CFD) software called XFOIL6.99 was utilized [27]. The software calculates the flow around the 2D-section profile, allowing all necessary data to be generated, such as C_{D0} , C_{Df} , C_{M2D} , and C_{P2D} , for each Reynolds number as well as AoA, see Section 2.2.4.

The open-source software was run through the programming software Matlab allowing extensive data to be calculated and analysed regarding a variety of different section profiles from the NACA 4-digit definition. The purpose of the investigation is to map the changes in characteristics when changing the profile thickness as well as the camber of the section profile. To do so, a variety of section profiles was chosen, see figure 4.3, and data were generated for different chord lengths, AoA, and different speeds of 10, 15, 20 knots. The chord length and the speed affect the Reynolds number implying the interest in investigating the behaviour due to these changes.

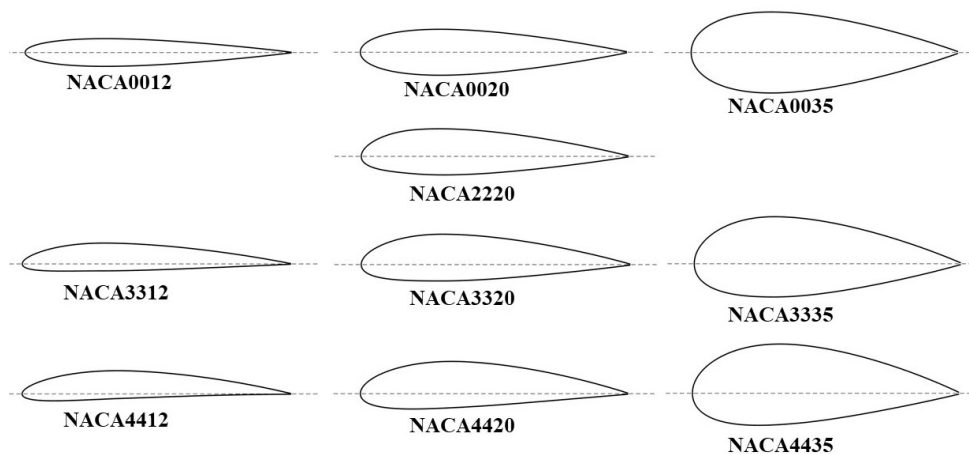
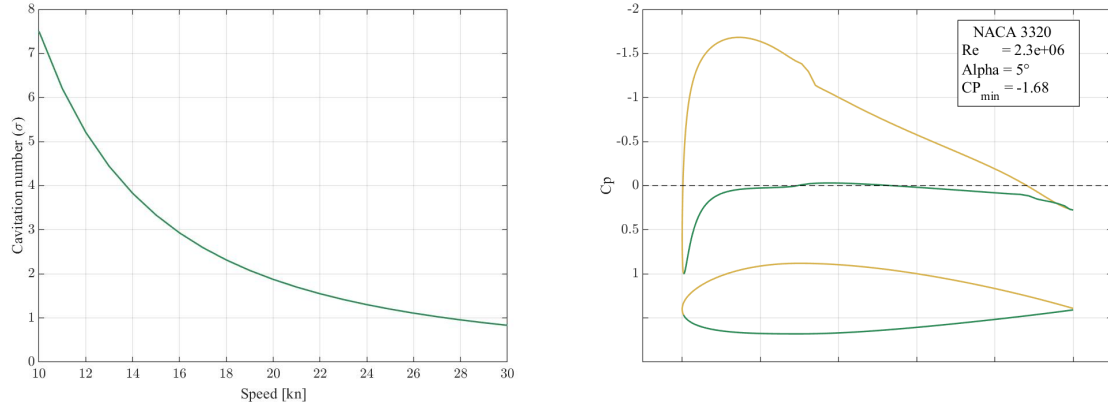

Figure 4.3: NACA 4-digit section profiles investigated

As the result of calculating the flow in regard to the different section profiles and running conditions, the software generates the pressure in relation to the section profile. Analysing the result, it is important to consider the risk of cavitation for the different section profiles. Cavitation occurs when $\sigma < |\min(C_p)|$, see section 2.2.2. Calculating the cavitation number, see equation 2.4, for different speeds indicates the exponential decrease, see

figure 4.5 (a), implying the increased risk for cavitation as speed increases. The pressure distribution in regard to the section profile NACA3320 in the running conditions of alpha (AoA) 5° and Reynolds number $2.3e+06$, is to be seen in figure 4.5(b).



(a) Changes in cavitation number as speed increases (b) Pressure distribution at a speed of 15kn and a chord length of 0.3m

Figure 4.4: Cavitation and pressure distribution in regard to the section profile

This running condition is equivalent to a speed of 15kn and a chord length of 0.3m, and yields a $min(C_p) = -1.68$, implying that $\sigma \leq |min(C_p)|$ and cavitation will not occur. As the aim is to obtain as high lift as possible without the risk of cavitation the C_L and $min(C_p)$ were plotted for each section profile, speed, and chord length, see Figure 4.5 for speed of 15kn and chord length of 0.3m, see Appendix D for others.

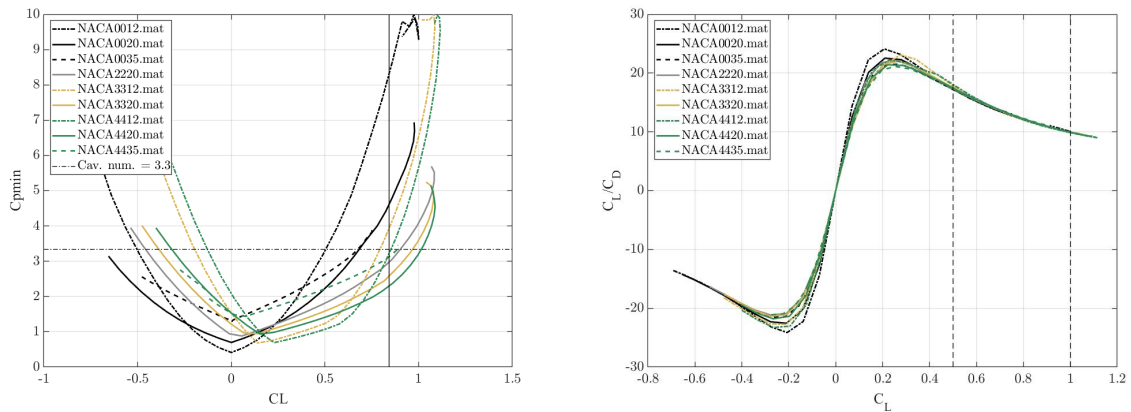

(a) Changes in C_p as C_L changes, for all section profiles (b) C_L/C_D indicating the efficiency of every section profiles at different C_L

Figure 4.5: Coefficients calculated for all section profiles at a speed of 15kn and a chordlength of 0.3m

Analyzing the result, the aim is to generate as high a lift as possible without the risk of cavitation, implying that C_L should be as high as possible without exciding the cavitation

limit (the right bottom quadrant). Further, it is clear that increasing the thickness of the section profile flattens and increases the value of the curve, implying that thick profiles have a lower constant pressure with less change in $\min(C_p)$ as C_L is increased. Increasing the curvature of the section profile pushes the curve towards the right as well as tilting it clockwise, implying a higher C_L not exciding the cavitation limit and less change in $\min(C_p)$ as C_L is increased.

The section profiles NACA3320 and NACA4420 are the ones generating the highest C_L values without exciding the cavitation number, although the NACA3320 generates higher negative C_L , implying the possibility to generate inverted lift. The NACA3320 was due to this chosen as a section profile for further development and calculation in the project (be aware that this section profile is sufficient but not optimized for the application).

4.3 Concept generation

The core development phase started with the concept generation, deriving a function tree to fully understand the product. To gain knowledge and inspiration regarding products generating lift/inverted lift, internal and external research was conducted by screening the competitor's solutions of foils on pod, and seeking other inventions. The concept generation was implemented by an external and internal brainstorming, concluding eight principal concepts and addressing their characteristics.

4.3.1 Function Tree

To divide the product into smaller pieces and parts, and fully understand the product and how it should perform, a Function Tree was created [29], by utilising the derived requirements and analysis of existing products. The Function Tree is a part of a larger tree, this is a branch of a larger context, where the top function is to reduce drag. In this project, the principal solution of a pod was given at the onset as a group solution to investigate, enabling the design-space to be narrowed and only this branch to be investigated, see Figure 4.6.

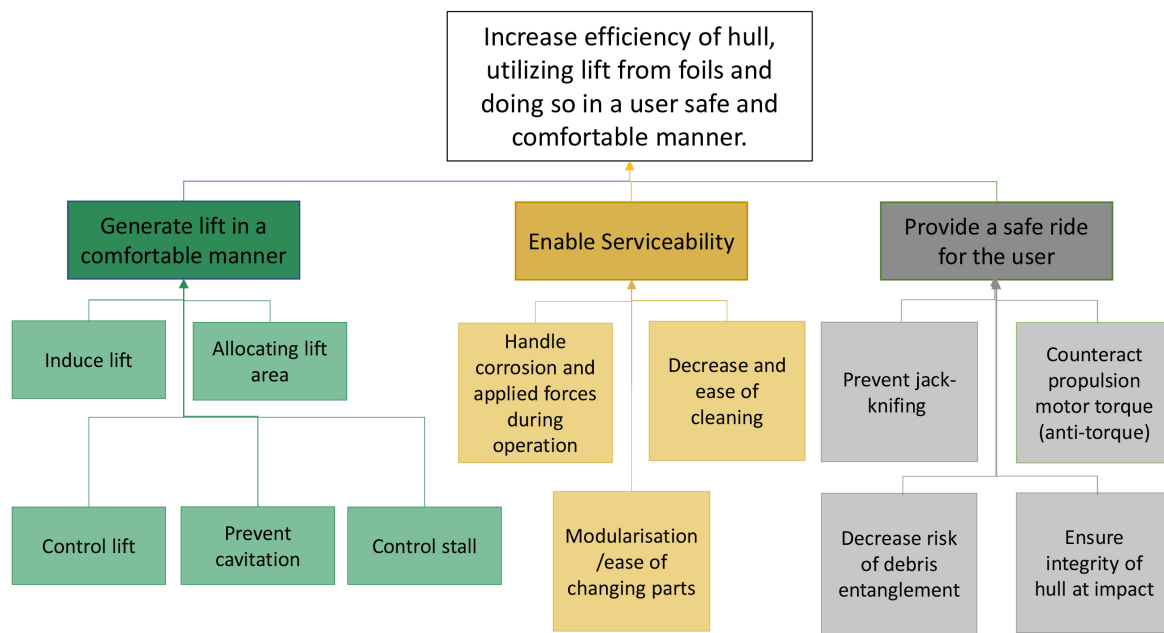

Figure 4.6: Function Tree of the product

The Function Tree contains a primary function which is to increase the efficiency of the hull, utilising lift from foils and doing so in a user safe and comfortable manner. This function is derived from the first question in Specification of the issues under investigation, see Section 1.2.2. The primary function could then be divided into three areas, with the corresponding functions as generating lift in a comfortable manner, enabling serviceability and providing a safe ride for the user. The three functions were split into 12 sub-functions, which are used later in the project during brainstorming and to be able to create sub-solutions to synthesise concepts.

4.3.2 Internal & External Research

Internal and external research was conducted through discussion with experts within the field, along with a screening of competitors' solutions for foils on pod, investigating car and aircraft wings and other special features by searching the internet. The purpose was to analyse in what fields foils are highly used, and to gain knowledge of which type of foils are used since there are numerous different variants. Further to gather knowledge about the foils' different characteristics and get inspired when generating ideas for the concepts.

Hydrofoils: The hydrofoils on the market today come in all different shapes and forms, and are implemented on for example leisure and commercial vessels, ferries, sailboats, catamarans and kites to lift the vessel/object out of the water. An article found categorised the foils by their different shapes and what distinguishes them. The foils were named by different letters since their shape resembles it, categorised as E, V, T, Y, L, U, O, C, J, L and S-foil, where some are more suitable for lifting the boat out of the water, some are used to stabilise it [46]. Investigation on the market shows a decent amount of foils on kites, many of them looking like a T-foil [47],[48]. Some do differ; one which is a biplane, has two foils stacked on each other [49], one which is shaped like an ellipse, it

resembles an O-foil [50], and one which is a biplane but attached on the tips instead of in the middle [51].

Regarding competition mono-hull and catamaran sailboats other shapes of foils are used, for example, the Y-foils [52] and a mix of two foils, L-foil and T-foil [53]. These are not only used to reduce displacement to create a vertical lift, but to generate a sideways lift to counteract some of the leeways, therefore other shapes than a T-foil are used [54]. On one sailboat the foils were only attached to the sides of the boat to stabilise it [55].

Foils implemented on leisure boats are not as commonly used as in the other fields. There are boats including two T-foils, one on each side, but attached by the foil and placed underneath the boat. The amount of immersion can be changed, optimising the operation and facilitating propulsion in shallow water [56]. The boat is implemented with a support foil at the stern. Further, a concept boat with a similar shape and set up of foils is found, but this has a mechanical adjustment system [57]. Another boat uses two L-foils, turned inwards resembling the attached T-foil [58]. The main task of all of these foils is to lift the boat out of the water. However, there is one company which provides a foil which is to be implemented on the stern of the boat. Instead of lifting the boat out of the water it is used to damper pitching and increase the efficiency of the operation [59].

Foils on pod: Investigating the field where foils are attached straight to the pod to generate lift, a few different concepts were found. The first one has foils that are slightly swept back elliptical planform [56]. The second solution is a tapered shaped foil with winglets and flaps to control the lift [60]. Some foils on the market are attached to the cavitation plates to generate lift and therefore reduce bow trim [27]. All of these were shaped as T:s.

Car wings: Wings which generate downforce was looked upon since it has the same main function as a foil just in the opposite direction. An E-foil was found to be implemented at a race car from a children's movie [61]. An old rally car [62] has a similar implementation, just not as many wings stacked on top of each other, called the triple-decker. These wings "grow" out of the rear window. Another rally car has a wing that is shaped like a closed-loop instead of a wing with ends to create downforce, implemented at the end of the car [63].

Closed wings on aircrafts: Not only regular-shaped wings can create lift for an aircraft, but a closed wing on aircraft is also another way to generate it. Several different closed wings are existing, but some of them have never been developed for commercial application. Four different designs emerged when screening; where the first one was the box wing [64] which is a square around the aeroplane. The rhomboidal is a similar one, but this one is skewed to the back of the aeroplane as well [65]. The last two are two different ring types; the flat annular wing [66] which extends from the front to the back of the aircraft, and the concentric wing and fuselage [67] which is a ring around the aircraft.

Special features: When conducting the research plentiful details and special features were found on both hydrofoils and wings. A main feature on wings is the winglet. It

is used to reduce the induced drag by reducing the vortices generated at the wingtip [68]. Vortex generators are another component used on wings and some foils. Their main attribute is to delay the separation along with controlling the separated flow [69]. The latter is the main purpose of wing fences (boundary layer fences), they can prohibit the whole wing to stall simultaneously [70].

To reduce interference drag, see Section 2.2.3, fairings and fillets can be used between the wing and the fuselage [71]. To increase lift force, on the other hand, flaps and slats can be used on the wing. These moves to increase the area of the wing, and therefore increases the generated force, and by rotating the flap and slat the camber of the wing can be alternated resulting in an increased lift force [72]. An interesting case was found regarding an interceptor edge attached to the trailing edge of the wing to increase the lift force [73], this may however increase the drag of the foil as well. Regarding stalling, there are some other design features to regulate its appearance. These are called wash-in and wash-out, whereas the latter is where the section profile at the root has a greater AoA compared to the section profile at the tip of the wing. This will enable a situation where the root stalls sooner than the tip of the wing. The opposite applies to wash-in [74], see Section 2.2.6.

4.3.3 Internal Brainstorming

The first brainstorming was conducted to generate ideas of principle concepts, generating a broad variety of conceptual ideas on how to generate lift by utilising hydrofoils on the pod. The brainstorming was kept to total concept solutions, preserving a manageable amount of solutions while investigating the design-space. The brainstorming was conducted by the project group, utilising the methodology of post-it brainstorming [26]. The session was divided into three short runs, allowing the participants to generate and discuss ideas in an iterative manner, the result of the session is to be seen in Figure 4.7.

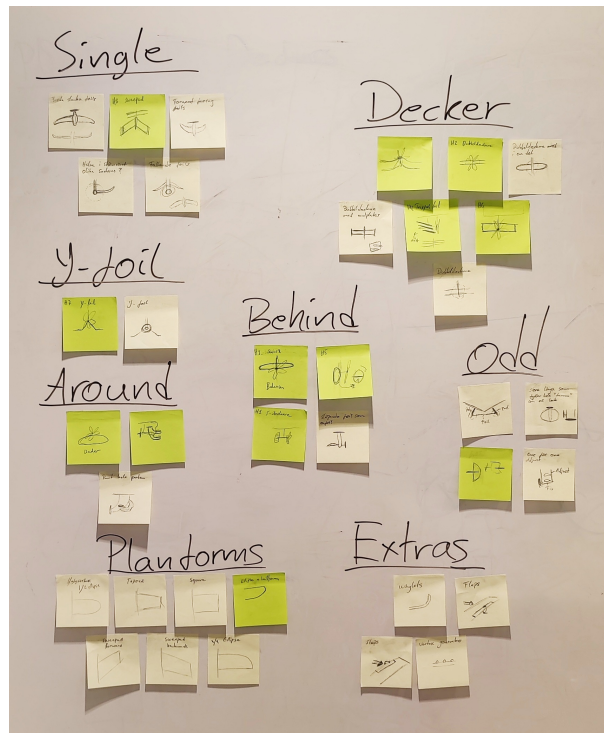

Figure 4.7: The groups as a result of the brainstorming session, declaring the concluded groups

As the total solutions were grouped, composing principal concept groups characterised by the overall solution of how to generate lift, complying with the main function in the function tree, see Figure 4.6. Further, there were categories with *Extras* and *Planforms*, containing winglets, flaps, slats, vortex generators, and different planforms of the foil itself. These sub-solutions can be utilised for all principal concept groups and are by that disconnected and individually addressed. The principle concepts are further addressed in the following Section 4.3.4.

4.3.4 Generated Concepts

In the following section, the concluded eight principle concepts are visualised and their characteristics addressed, accounting for the freedom in design and their possibilities.

Principal Concept A: Single

The principle concept *A: Single*, is characterised by a pair of foils attached to the sides of the pod, enabling lift to be generated. The similarities to other hydrofoiling products and aeroplanes are distinct for this principle concept. The amount of generated lift can be controlled by rotating the foils to decrease/increase the AoA, implying low complexity of functionality and the mechanical system. A drawing of the principle concept was conducted, enabling an understanding of how the concept can be characterised, highlighting problematics, and fostering new ideas, see Figure 4.8.

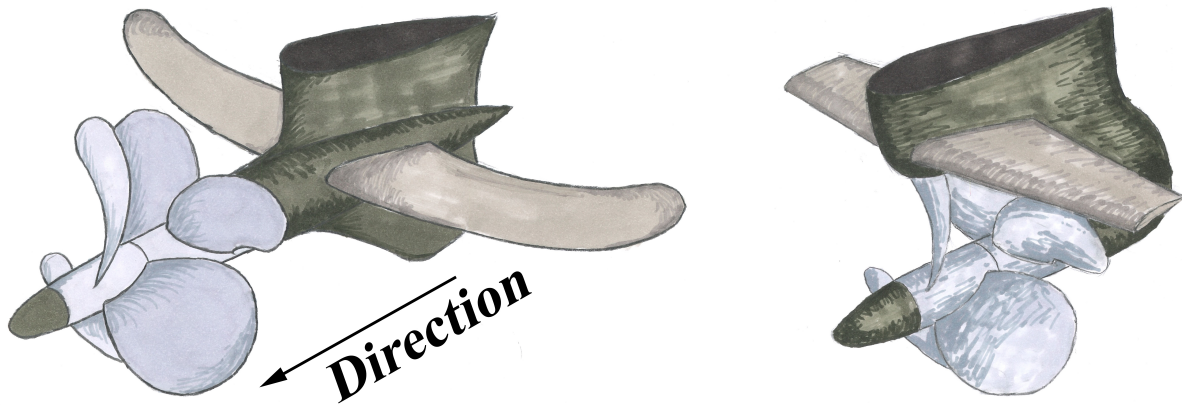

Figure 4.8: Visualisation of the principle concept *Single*

The principle concept can be utilised with different types of planforms, enabling different characteristics of the foil, see Section 2.2.6, slightly swept-back leading edge can improve the prevention of debris entanglement. Allocating the foils at different positions on the pod, can change the characteristics of the system as the impact of the forces generated is changed. Attaching the foil above the propellers the foil can plausibly be working as a cavitation plate for the propellers, although this manoeuvre requires careful considerations regarding the interaction between propellers and foils.

The viscous speed behind the propellers is increased in regard to the free flow stream, implying that the foil might be exposed to differences in speed along the span width. To manage these differences, the section profile along the wingspan can be varied, optimising the lift and avoiding cavitation at different circumstances and speeds. The foil can be designed with wash-in and wash-out to change the stall characteristics and is depending on the used planform, see section 2.2.6. As the principle concept can utilise simple straight leading/trailing edges, slats, flaps, winglets, and vortex generators are easily attached.

Principal Concept B: Decker

The principle concept *B: Decker*, is characterised by multiple foils attached to each side of the pod, focusing on 2-3 foils at each side, dividing the required lift force among multiple span widths, enabling the total width of the concept to be minimised. The foils can be located in a horizontal row, vertical row, or spread out along the side of the pod, although the hydrodynamic interaction between the foils has to be carefully considered. The amount of generated lift can be controlled by adjusting the AoA by rotational motion for all foils, implying a high complexity of the mechanism if the system enables individual control of each foil. A drawing of the principle concept was conducted, enabling an understanding of how the concept can be characterised, highlighting problematics, and fostering new ideas, see Figure 4.9.

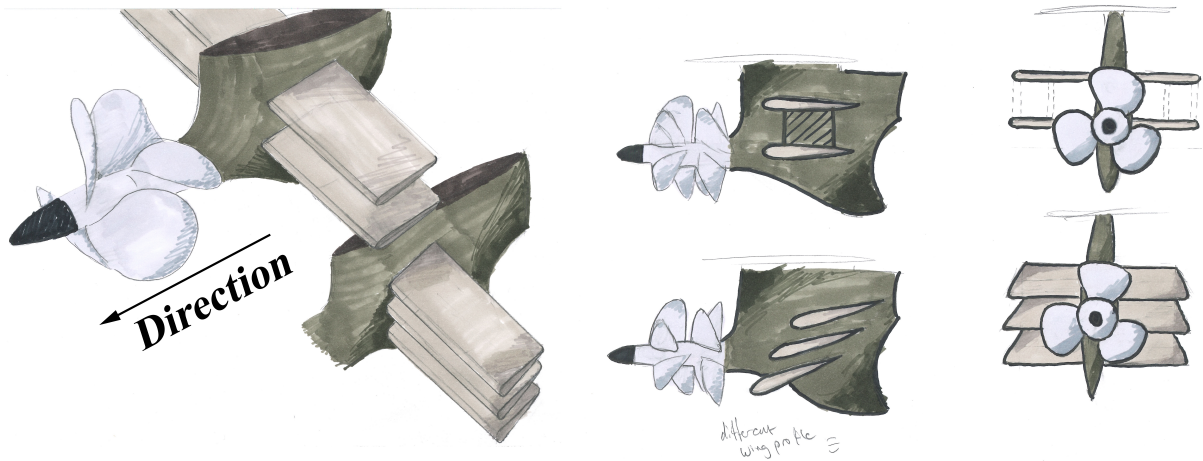

Figure 4.9: Visualisation of the principle concept *Decker*

The principle concept can be utilised with different planforms, wash-in/wash-out, and varying section profiles of the principle concept *A: single*. The principle concept enables the foils to inherit different section profiles extending the possible characteristics of the group of foils, and allowing extensive configurations to be explored. Further, the multiple foil solution enables the structural integrity to be re-enforced and reduces the generated vortexes by connecting the foils with end-plates.

Principal Concept C: Y-foil

The principle concept *C: Y-foil*, is characterised by a pair of foils attached to the sides of the pod forming the shape of a Y, a wide stance generating sufficient moment, and is greatly influenced by the development within the sail racing industry. The shape of the wings can be varied in many different designs, allowing large freedom of design. The wide stance improves the roll stability of the system, counteracting unwanted roll motions of the vessel, although a wide stance comes with more surface and which decreased the overall efficiency. A drawing of the principle concept was conducted, enabling an understanding of how the concept can be characterised, highlighting problematics, and fostering new ideas, see Figure 4.10.

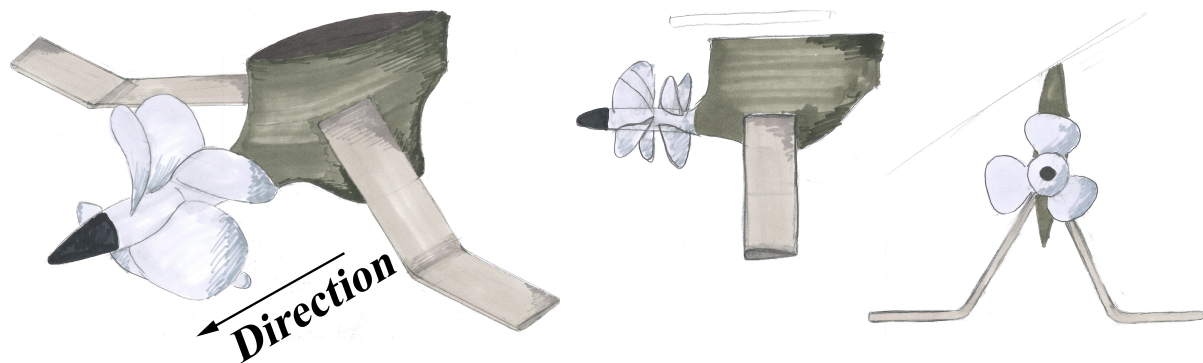

Figure 4.10: Visualisation of the principle concept *Y-foil*

The principle concept can be utilised with different planforms, wash-in/wash-out, and

varying section profiles of the principle concept *A: single*. The principle concept allows the radius between the foil and the pod to be large, minimising the vortex generated as the two boundary layers interact. Further, the lifting area of the foil is dislocated from the accelerated viscous stream generated by the propellers, and actively adjusting the AoA of the system requires large motions to be performed, increasing the complexity of the mechanisms.

Principal Concept D: Behind

The principle concept *D: Behind*, is characterised by a foil or pair of foils attached behind the pod itself, implying a continuous wingspan and lifting line, increasing the overall efficiency, see Section 2.2.4. By utilising multiple wingspans and a continuous lifting line the width of the concept can be minimised, excluding the edges of the foils by using endplates, the generated vortexes can be minimised. A drawing of the principle concept was conducted, enabling an understanding of how the concept can be characterised, highlighting problematics, and fostering new ideas, see Figure 4.11.

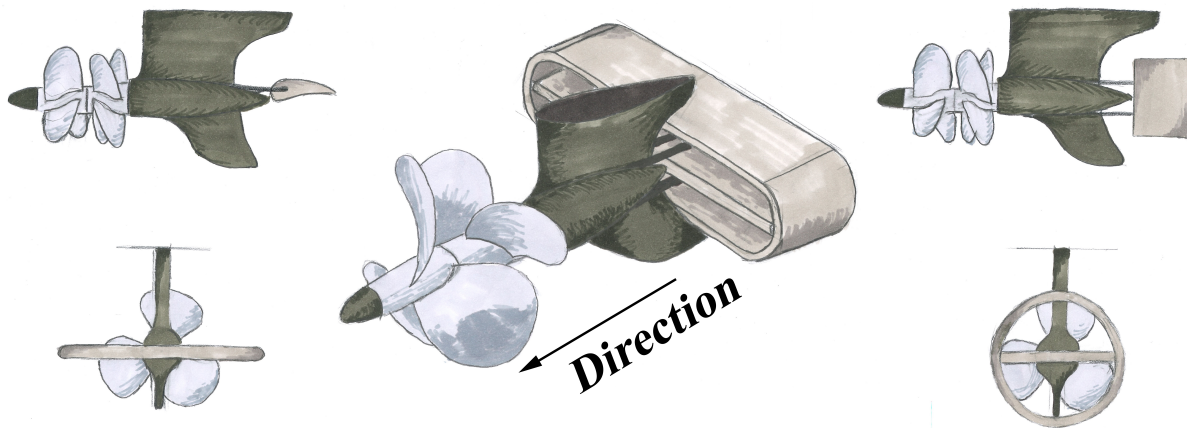

Figure 4.11: Visualisation of the principle concept *Behind*

The principle concept can be utilised with different planforms, wash-in/wash-out, and varying section profiles of the principle concept *A: single*. High freedom of design, enables a large variety of shapes to be utilised, changing the characteristics of the system. Rounded foils focus the forces towards the centre, implying that less moment counteracts the rolling motion of the vessel, although maintaining equivalent characteristics independently of roll-angle. Further, actively adjusting the AoA of the foil requires a complex mechanism as the foil is attached behind the pod.

Principal Concept E: Comes Around

The principle concept *E: Comes Around*, is characterised by a foil continuously swept around the pod, enabling the foil to be manufactured in one piece. The continuous foil features no edges, implying that the vortices generated can be minimised, and a continuous lifting line of the bottom part, increases the efficiency and enables a compact solution. A drawing of the principle concept was conducted, enabling an understanding of how

the concept can be characterised, highlighting problematics, and fostering new ideas, see Figure 4.12.

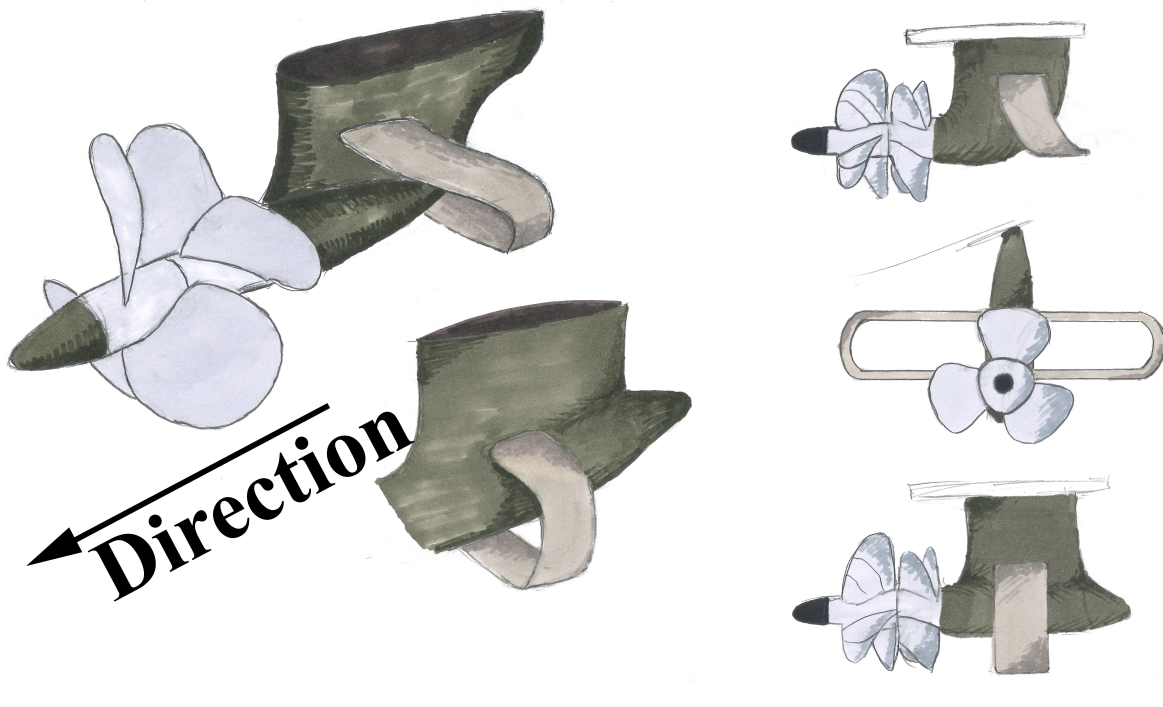

Figure 4.12: Visualisation of the principle concept *Comes around*

The principle concept enables high freedom of design as different section profiles and differences in primary AoA can be utilised to vary the characteristics along the foil, handling cavitation and stall characteristics. Preferably the top and bottom section profiles inherit different primary AoA allowing them to stall one at a time. Further, the wing can be characterised by a flexible structure allowing the AoA on each side to be individually adjusted by rotational motion, twisting the foil. The twist enables the side sections to be angled, generating a moment counteracting the moment from the motor, implying that the pod can be redesigned and optimised without considering the moment from the motor.

Principal Concept F: Odd Plate

The principle concept *F: Odd Plate*, is characterised by a short wingspan and a long section length, minimising the width of the system, and maintaining the lift area. The amount of lift generated can be controlled by adjusting the AoA with rotational motion, the system allows the foil to be manufactured as one or two pieces, implying individual or joint adjustment of AoA to be utilised. A drawing of the principle concept was conducted, enabling an understanding of how the concept can be characterised, highlighting problematics, and fostering new ideas, see Figure 4.13.



Figure 4.13: Visualisation of the principle concept *Odd Plate*

The principle concept can be utilized with different planforms, wash-in/wash-out, and varying section profiles as the principle concept *A: single*. The half elliptical planform keeps the solution compact. Further, the long section length entails more torque required to rotate the system, increasing the robustness of the mechanical system.

Principal Concept G: Odd Dual

The principle concept *G: Odd Dual*, is characterised by the same characteristics as the *B: Decker*, see Section 4.3.4, although this principle concept differs as only one pair of the foils are adjustable, the other pair are fixed at a predetermined AoA. This enables the fixed foil to always counteract the unwanted motion of the hull. As the hull's AoA increases the lift increases and by that reduces the AoA of the hull, vice versa for negative AoA of the hull, implying the foil starts to generate a negative lift force, pushing the bow upwards. The adjustable pair of foils can be utilised to increase the effectiveness of the fixed pair of foils or counteract it, implying a dynamic system capable of generating lift and inverted lift, being actively adjustable. A drawing of the principle concept was conducted, enabling an understanding of how the concept can be characterised, highlighting problematics, and fostering new ideas, see Figure 4.14.

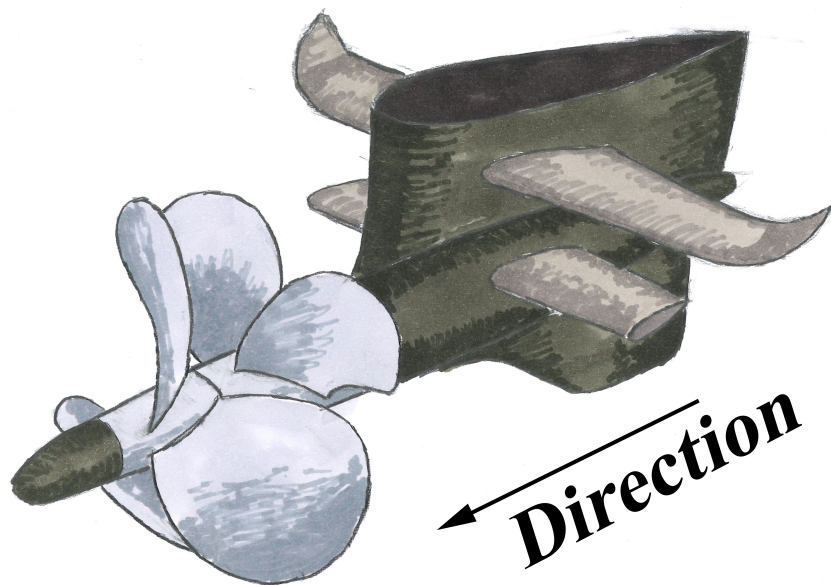

Figure 4.14: Visualisation of the principle concept *Odd Dual*

The principle concept can be utilised with different planforms, wash-in/wash-out, and varying section profiles of the principle concept *A: Single*. The principle concept can be modularised to enable different options in the product line, the fixed foils will always be included and the adjustable foils can be an additional option to purchase, targeting a larger customer group. Further, there is a possibility to utilise different span widths on the two pairs of foils, changing the interaction between them, enabling different possibilities of characteristics for the system. The principle concept is compatible with the extra solutions such as winglets, slats, flaps, and vortex generators.

Principal Concept H: Odd Berit

The principle concept group *G: Odd Berit*, is characterised by dislocating the propellers from each other, fitting a pair of foils in between and behind. Utilising one fixed pair of foils and one pair being adjustable implies similar characteristics as the *G: Odd Dual*, see Section 4.3.4, while maintaining a compact system. Further, the foils can take the form of a barrel, swept around the propellers, increasing the lifting area while minimising the spaciousness. A drawing of the principle concept was conducted, enabling an understanding of how the concept can be characterised, highlighting problematics, and fostering new ideas, see Figure 4.15.

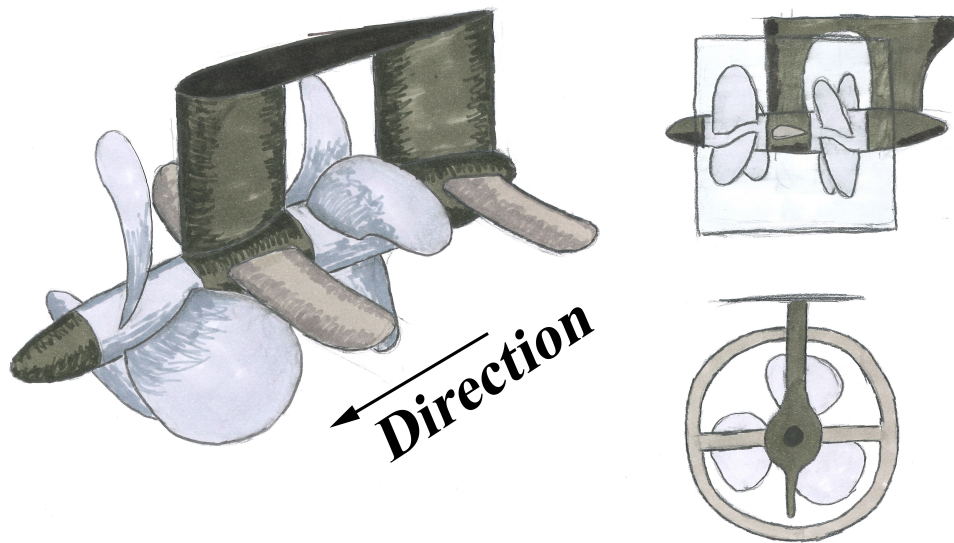

Figure 4.15: Visualisation of the principle concept *Odd Berit*

The principle concept can be utilised with different planforms, wash-in/wash-out, and varying section profiles of the principle concept *A: Single*. Dislocating the propellers and fitting a pair of foils in between, implies that the foils will be exposed to non-laminar flow and the effects have to be carefully considered. Although the dislocation of the pod-legs enables the possibility to angle the legs, generating a moment counteracting the motor torque. Further, the dislocated propellers enable individual control of each propeller with individual driveshaft and motors, optimising the efficiency of the system.

4.4 Concept Evaluation & Scoring

The eight generated principal concepts are evaluated quantitatively and qualitatively, enabling scoring and comparison of the principle concepts. The quantitative evaluation concludes the differences in generated lift when changing the size of the foil. The qualitative evaluation is established upon elaborately discussions and theories regarding wings and hydrofoils. The scoring and comparison of the principle concepts are performed with systematical methods and addresses why certain concepts were excluded.

4.4.1 Calculations & Evaluation

As the principle concepts were generated and clarified, calculations and evaluations of each principle concept were conducted. The calculations are based upon the wing theory and the data generated with the open-source software, see Section 2.2. Calculations were conducted for different span widths (b) and chord lengths (c) to obtain a sufficient design-space, distinguish when cavitation might occur, and the lift acquired to fulfil the requirement of $7500N$, see no. 1.8 in Table 4.3. The generic equations consider straight wings with the defined planforms, see Section 2.2.4 and Section 2.2.6, implying principle concepts with more complicated foil geometries could not be calculated, although qualitative evaluation for each concept was conducted in collaboration with experts at the

company. The calculations were conducted with a planform with a taper ratio of 45% as this is equal to an elliptical lifting line, being the most efficient planform together with the elliptical planform, see Section 2.2.6.

The skin friction drag is approximated in regard to a constant-chord planform to simplify the equations, overestimating the induced skin friction drag as the area of a tapered planform is less than a constant-chord planform, see Section 2.2.3 and 2.2.6. The interference drag between multiple foils is not considered, neglecting the possible hydrodynamic effects and contemplating the foils as individual foils in a free viscous stream. The interference drag between the foil and the pod is underestimated, as the elliptical lifting line is defined from wing tip to wing tip, and does not consider the interference effect, see Section 2.2.3 and 2.2.4. Further, sources of error in regard to approximations and assumptions within the calculations, are concluded in a series of discussions, see Section 7.1.

A: Single

The principle concept *Single* has a simple and conservative design, enabling a large variety of designs and an easy understanding of the functionality. As this type of wings/hydrofoils has been developed and extensively tested within the industry, the opportunity for success is increased, although the rotational motion adjusting the AoA is immature, decreasing the TRL.

Implementing a slightly swept-back leading edge increases the resistance of debris entanglement, utilised with an elliptical or tapered planform optimising the efficiency of the principle concept. Calculations regarding the efficiency (L/D), span width (b), and chord length (c) were conducted, implying different aspect ratio (AR) and amount of lift force generated, see Figure 4.16. The * represents the point where cavitation starts to occur, and should not be surpassed. AoA being the acquired Angle of Attack of the hydrofoil to generate the required lift force of $7500N$.

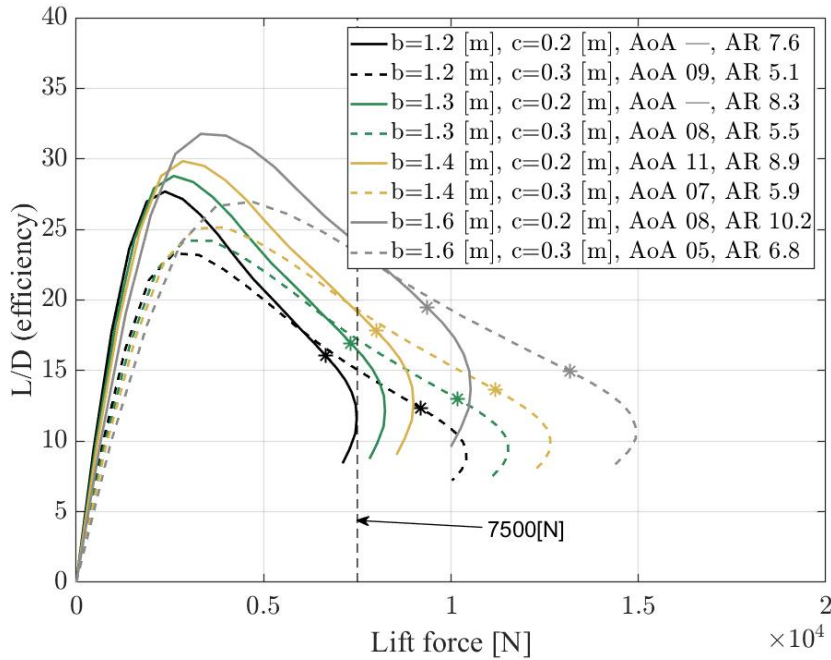

Figure 4.16: L/D vs Lift force for the concept *Single* at viscous speed of 15kn

As seen, to achieve decent efficiency $L/D > 15$, see no. 1.11 in Table 4.3, generating the acquired lift without cavitation and maintaining some margin until cavitation, the foil has to be approximately, $1.3 \times 0.3m$, $1.4 \times 0.3m$ or $1.6 \times 0.2m$, where the wide foil inherits higher efficiency although being more spacious. By increasing the span width from $1.3m$ to $1.4m$ /* efficiency increases and the required AoA decreases sufficient enough to validate the increase of spaciousness. Further, the $1.4 \times 0.2m$ foil manages to generate the acquired lift, although the margin to the point of cavitation is narrow. The $1.4 \times 0.3m$ foil was chosen to be the best trade-off between spaciousness and efficiency, implying this will be the measurement regardless of planform.

Allocating the foil above the propeller can significantly change the hydrodynamic effect of both propellers and foil. Utilising the foil behind the propellers enables the foil to not disturb the propellers and is optimised for the indifference in viscous speed. The utilisation of extra features such as flaps, slats, and vortex generators significantly increases the complexity of the system and the conditions for biofouling, implying the risk of implementing such features. Winglets can be utilised to increase the efficiency of the wing, although extending the width of the wing implies a greater gain of efficiency [75]. Indicating that winglets should be utilised if it does not acquire any additional complexity of manufacturing.

B: Decker

The principle concept *Decker* is not widely used within the hydrofoil industry, although some products incorporating multiple foils have emerged on the market. The concept of implementing multiple foils has been extensively utilised within the aeroplane industry, implying a decent understanding of the characteristics. Rotating multiple foils requires ad-

4. Development of hydrofoil concepts

vanced mechanics and no products have been discovered utilising these conceptual ideas, implying low TRL of the principle concept.

Further, the principle concept can utilise the same swept back leading edge and planforms as the *Single*, although the utilisation of end-plates mostly increases the risk of debris entanglement. Calculations regarding the efficiency (L/D), span width (b), and chord length (c) were conducted, implying different aspect ratio (AR) and amount of lift force generated, see Figure 4.17, where the * represents the point where cavitation starts to occur, and should not be surpassed. AoA being the acquired Angle of Attack of the hydrofoil to generate the required lift force of 2500N and 3750N.

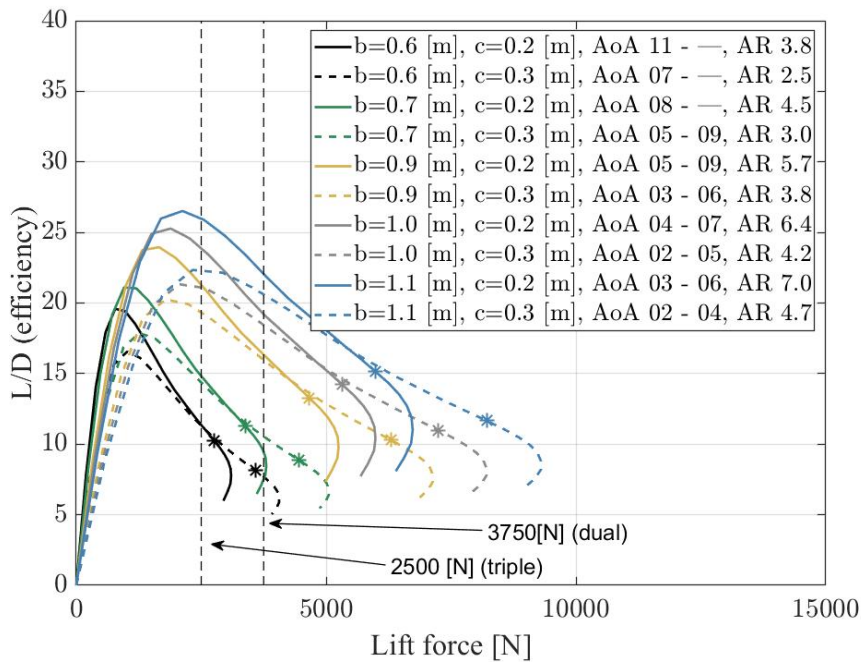

Figure 4.17: L/D vs Lift force for the concept *Decker* at viscous speed of 15kn

As seen the dual-foil configuration acquires a wingspan of approximately 1.0m independently of the chord length, although the smaller chord length implies an increase in AR and increase in peak efficiency, and is by that preferred. For the triple-foil configuration, the 0.6x0.3m foil is sufficient and the 0.7x0.2m increases the AR and efficiency, although both being below $L/D = 15$ at the acquired lift generated, not fulfilling the requirements, see no. 1.11 in Table 4.3. The larger foils can be utilised as a dual and triple configuration, implying the triple configuration increases the efficiency by utilising less of the total capacity of the foil, pushing the point of operation towards the peak of the efficiency curve. Although a triple configuration entails a more complex system and increases the risk of failure and cost.

Evaluation of the principle concept of the dual configuration with measurements of 1.0x0.2m was considered to inherit the most equitable trade-off between efficiency and spaciousness, generating the acquired lift with the same efficiency as the *Single* 1.4x0.3m foil.

C: Y-foil

The principle concept *Y-foil* is utilising a wide stance and angled lifting line, decreasing the efficiency as the area utilised to generate lift is extended, increasing the skin friction drag, see Section 2.2.3. The principle concept can be utilised if the case-specific usage requires a high rolling moment to be generated, as the wide stance entails the possibility of fulfilling this requirement. Further, the hydrofoil requires a lot of space and torque to perform a rotational motion changing the AoA, implying a robust mechanical system is a necessity. The measurements of the principle concept are assumed to be similar to the *Single*, where the span width is measured horizontally from the root to the tip of the foil. The principle concept can utilise the same features and foil configurations as the *Single* optimising and changing the behaviour of the system.

D: Behind

The principle concept *Behind* is requiring a complex mechanical system adjusting the AoA, entailing a sufficient amount of disadvantages to not include the mechanical system. As the mechanical system implies a high risk for biofouling, debris entanglement, and mechanical failure, entailing increased drag and a decreased efficiency. Providing the principle concept without active adjustment of AoA decreases customer satisfaction and efficiency as the system can not be controlled or optimised for specific running conditions. Further, the hydrofoil itself can be designed to optimise the efficiency as there is no interruption in the lifting line, implying the hydrofoil is comparable to the calculations of *Decker*, although expected to be more efficient as the edge of the foil can be eliminated, implying a probability of decreasing the extent of the vertices.

E: Comes Around

The principle concept *Comes Around* is one of the most effective and compact solutions, minimising the risk of failure compared to other compact and innovative solutions such as *Behind* and *Odd Berit*. No generic equations were found that consider the positive effect by eliminating the edge of the foil and minimising vortices generated, although experts conclude that there is a strong possibility of increased efficiency. If no vortices were generated the width of the principle concept could be compared to dividing the single-foil into two ($1.4/2 = 0.7m$), see Figure 4.16. If the vortices generated are equal to the *Decker* the concept is maximum the width is equal to the *Decker*, implying $0.9m$, see Figure 4.17. This implies that the width of the concept will be between $0.7 - 0.9m$ maintaining sufficient efficiency and margin before cavitation.

The possibility of utilising a flexible structure enabling a broad span of characteristics and individual AoA adjustments on each side, inherits an immense technological challenge, although introducing possibilities not possible with other principle concepts. The foil is manufactured as one part, decreasing the extent of assembly. The design is complex, demanding advanced manufacturing methods and limits the possibility of material choices. Further, the hydrodynamic interaction between the foils has to be carefully considered, and allocating the lower foil backward increases the moment at attachment, implying an increase in moment required to adjust the AoA by rotational motion, and by that the

necessity of a stronger mechanical system.

F: Odd Plate

The principle concept *Odd plate* is similar to the *Single*, it does distinguish in AR as the principle concept strives to minimise the spaciousness by decreasing the span width and increasing the chord length. The same configurations and planforms suitable for the *Single* are applicable to the principle concept. Calculations regarding the efficiency (L/D), span width (b), and chord length (c) were conducted, implying different aspect ratio (AR) and amount of lift force generated, see figure 4.18, where the * represents the point where cavitation starts to occur, and should not be surpassed. AoA is the acquired Angle of Attack of the hydrofoil to generate the required lift force of $7500N$.

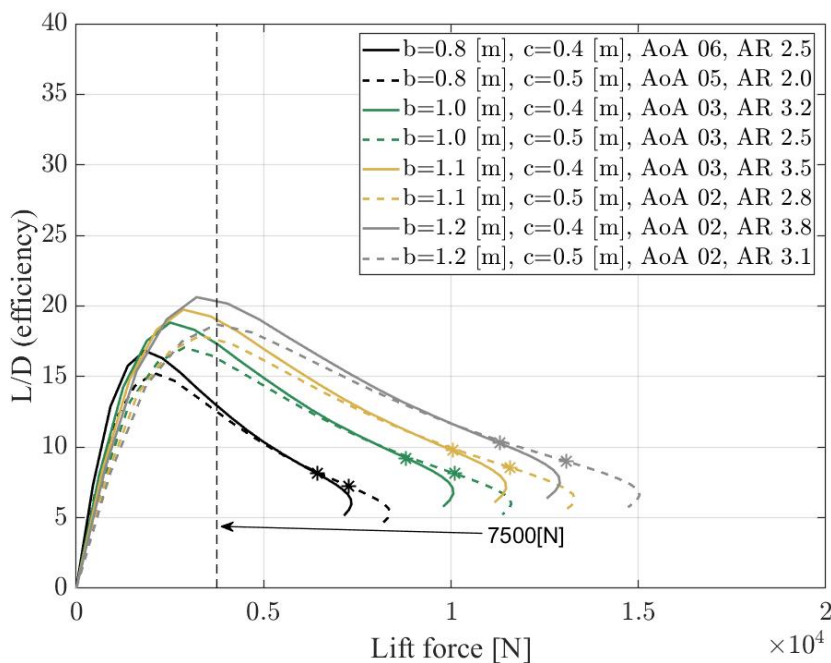

Figure 4.18: L/D vs Lift force for the concept *Odd plate* at viscous speed of $15kn$

As seen, the required lift force can be generated with a span width $\geq 1.0m$, as the AR is decreased with an increase in chord length, the efficiency of the hydrofoil is decreased, indicating the importance of striving for a higher AR. If the foil is $1.2 \times 0.4m$ the $L/D \approx 15$ implying ≈ 5 less than a $1.4 \times 0.3m$ foil. Further, the increase of chord length is expected to acquire a high moment to change the AoA, requiring a stronger mechanical system. The principle concept is not suitable if the specific usage case does not forcefully require a small decrease in span width.

G: Odd Dual

The principle concept *Odd Dual* inherits the same characteristics as the *Decker* although defined as a two foil configuration and one of the pairs being actively adjustable by rotational motion changing the AoA. This configuration enables other characteristics of

the system, although increasing the complexity of the control system. As the principle concept enables one pair of foils to possibly be within the high-velocity stream behind the propellers, calculations for $15kn$ and $20kn$ streams were conducted. The calculations conducted regarding the efficiency (L/D), span width (b), and chord length (c), implied different aspect ratio (AR) and amount of lift force generated, see Figure 4.19, where the * represents the point where cavitation starts to occur, and should not be surpassed. AoA is the acquired Angle of Attack of the hydrofoil to generate the required lift force of $3750N$.

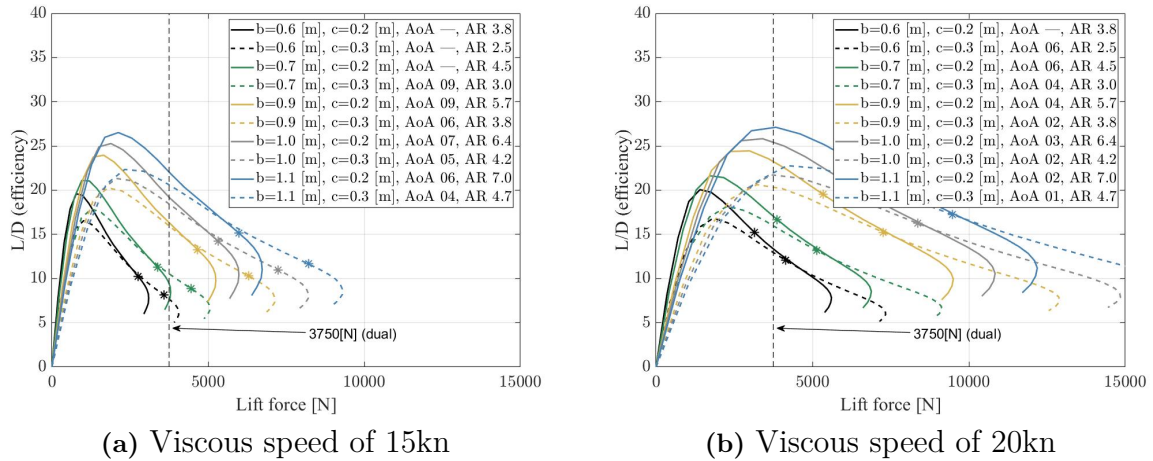

Figure 4.19: L/D vs Lift force on the *Odd Dual* for different viscous speeds

As seen in Figure 4.19a, the foil located in the free flow stream has to be at least $S = 0.9m$ independently of the chord length, implying that the $0.9 \times 0.2m$ configuration can be utilised to minimise spaciousness still fulfilling the requirements. The $1.0 \times 0.2m$ configuration can be utilised to achieve similar efficiency as the *Singel* generating the acquired lift force. Figure 4.19b indicates that the foil can be as small as $0.7 \times 0.3m$ still generating the acquired lift force, although the span width is larger than the accelerated viscous stream behind the propellers, implying that the whole hydrofoil will not experience the accelerated stream, decreasing the lift generated.

H: Odd Berit

The principle concept *Odd Berit* is the most innovative concept of them all, dividing the *Decker* characteristics and allocating the pair of foils between and after the propellers. Therefore the hydrofoils are no longer exposed to laminar flow, rather a rotating flow generated by each propeller. The rotating flow contributes to an increased risk of unexpected hydrodynamic effects to occur, changing the behaviour of the hydrofoils.

Allocating a pair of foils between the propellers increases the risk of debris entanglement and its severity, as the hydrofoil might catch debris and entangle the propellers, leading to loss of propulsion. These risks have to be compared and evaluated to the decrease in spaciousness and increase in efficiency, gained by utilising individually controlled propulsion motors. Further, the calculations for the *Decker* are valid for the principle concept,

4. Development of hydrofoil concepts

although the effect of allocating the foils in a horizontal row is uninvestigated, accordingly to the interference drag, see section 2.6.

4.4.2 Concept Scoring

To enable a systematic evaluation of the eight principal concepts a scoring method incorporating a Kesselring matrix and derived criteria concluded with the company and from the requirement specification was utilised, with the outcome of four remaining concepts. The remaining concepts were evaluated in a new Kesselring matrix to assess the relevance of the decision.

Kesselring matrix - first iteration

A kesselring matrix evaluates the performance of the concepts in regard to the fulfilment of the criteria, implying that the importance of the criteria can be incorporated. To be able to score the principal concepts in a Kesselring matrix [30], [31], concept criteria were derived and their factor of weight determined. The eleven concluded criteria include several aspects such as the user, the performance of the foil, complexity of manufacturing, and safety. The criteria are connected to the non-functional and functional requirements in the requirement specification, see Appendix F.

The criteria were divided into different subjective and objective values, to be able to determine the value for each criteria and principal concept in the Kesselring matrix, see Appendix G. The value 1 is ranked as the lowest value and 5 is ranked as the highest value. Further, a PCM was conducted in collaboration with experts at the company, to determine the weight factors of the criteria, calculate the factor of weights by comparing the criteria against each other enabling the scoring of the concepts to be conducted. In the PCM the 0 indicates that the criteria are valued lower than its comparison, 1 is higher and 0.5 is the same [32], see Appendix H.

Kesselring matrix																			
Criteria		Solution alternative																	
		Ideal		A Single		B Deckers		C Y-foil		D Behind		E Comes Around		F Odd Plate		G Odd Dual		H Odd Berit	
Name	W	v	t	v	t	v	t	v	t	v	t	v	t	v	t	v	t	v	t
Efficiency (L/D)	0,155	5	0,77	4	0,62	3	0,46	3	0,46	4	0,62	5	0,77	1	0,15	3	0,46	3	0,46
Spaciousness	0,164	5	0,82	2	0,33	4	0,65	1	0,16	4	0,65	5	0,82	4	0,65	4	0,65	4	0,65
Manufacturing complexity/specialization/cost	0,100	5	0,50	5	0,50	3	0,30	3	0,30	1	0,10	2	0,20	4	0,40	4	0,40	3	0,30
Required volume of material	0,027	5	0,14	5	0,14	3	0,08	3	0,08	2	0,05	3	0,08	3	0,08	4	0,11	3	0,08
Complexity of machinery	0,082	5	0,41	5	0,41	1	0,08	1	0,08	1	0,08	3	0,25	3	0,25	3	0,25	3	0,25
Maintenance required (company/service)	0,064	5	0,32	5	0,32	2	0,13	4	0,25	1	0,06	3	0,19	4	0,25	3	0,19	2	0,13
Technical feasibility (TRL)	0,000	5	0,00	4	0,00	2	0,00	4	0,00	1	0,00	1	0,00	3	0,00	3	0,00	1	0,00
Risk for debris entanglement	0,073	5	0,36	5	0,36	2	0,15	4	0,29	1	0,07	2	0,15	5	0,36	3	0,22	2	0,15
User satisfaction	0,155	5	0,77	4	0,62	4	0,62	3	0,46	3	0,46	4	0,62	2	0,31	3	0,46	3	0,46
Safety	0,091	5	0,45	2	0,18	3	0,27	1	0,09	2	0,18	4	0,36	3	0,27	4	0,36	3	0,27
Innovation	0,091	5	0,45	2	0,18	4	0,36	2	0,18	5	0,45	5	0,45	2	0,18	4	0,36	5	0,45
T=Σ ti		5,00		3,65		3,11		2,37		2,75		3,89		2,92		3,47		3,21	
T/Tmax		1		0,73		0,62		0,47		0,55		0,78		0,58		0,69		0,64	
Standard deviation		0		1,04		0,78		1,01		1,26		1,12		0,84		0,50		0,68	
Number of weak points		0		3		4		4		7		3		3		0		3	
Ranking				2		5		8		7		1		6		3		4	
Decision		1-4 continues to the second iteration																	

Figure 4.20: Evaluation of the principle concepts in the first iteration with a Kesselring matrix

The result from the PCM shows that the criteria Efficiency, Spaciousness and User satisfaction entail a high factor of weight. TRL scored 0 since the concepts entail a high level of innovation and the insignificance of TRL 1-3 for the company as they all require extensive further development. The takeaways from the first Kesselring matrix was that the principal concept *Singles* scores evenly on appreciably many of the criteria, with only a few weak points. This is similar to the principal concept *Odd Dual* which has fewer weak points, implying that these concepts fulfill many of the requirements. These concepts do not possess a complex design, which implying for more ease in manufacturing and complexity of machinery.

Performing the lowest in the Kesselring matrix is the principal concept *Behind* has a considerable amount of weak points, not performing at the criteria connected to manufacturability and maintenance. For this concept, it is difficult to create a solution to adjust the angle of attack, which is a desire in the Requirement specification, see no. 1.5 in Table 4.3. Since there is a complex design, the severity of maintenance increases since it becomes more difficult to clean. As for the *Y-foil* it becomes spacious which implies safety risks when manoeuvring the boat in different directions. The *Odd Plate* scores low at Efficiency, since it has a wide cord length, increasing the drag and therefore decreasing efficiency. The four remaining concepts where *Single*, *Comes Around*, *Odd Dual* and *Odd Berit*.

Kesselring matrix - Robustness

The robustness of the first evaluation regarding the four remaining concepts was tested in a Kesselring matrix, see Figure 4.21. This was done to investigate if the ranking and the result of the principal concept would be equivalent, and to assess the relevance of the decision. The criteria with the highest weight factor; Efficiency, Spaciousness, and User satisfaction, were removed to evaluate their influence on the result.

Kesselring matrix											
Criteria		Solution alternative									
		Ideal		A Single		E Comes Around		G Odd Dual		H Odd Berit	
Name	W	v	t	v	t	v	t	v	t	v	t
Manufacturing complexity/specialization/cost	0,196	5	0,98	5	0,98	2	0,39	4	0,79	3	0,59
Required volume of material	0,054	5	0,27	5	0,27	3	0,16	4	0,21	3	0,16
Complexity of machinery	0,161	5	0,80	5	0,80	3	0,48	3	0,48	3	0,48
Maintenance required (company/service/user)	0,125	5	0,63	5	0,63	3	0,38	3	0,38	2	0,25
Technical feasibility (TRL)	0,000	5	0,00	4	0,00	1	0,00	3	0,00	1	0,00
Risk for debris entanglement	0,143	5	0,71	5	0,71	2	0,29	3	0,43	2	0,29
Safety	0,161	5	0,80	2	0,32	4	0,64	4	0,64	3	0,48
Innovation	0,161	5	0,80	2	0,32	5	0,80	4	0,64	5	0,80
T=Σ ti		5,00		4,04		3,14		3,57		3,05	
T/Tmax		1		0,81		0,63		0,71		0,61	
Standard deviation		0		1,09		0,91		0,50		0,81	
Number of weak points		0		2		3		0		3	
Ranking				1		3		2		4	
Decision		1-4 continues to the second iteration									

Figure 4.21: Verification of the concept with the second Kesselring matrix

As a result, the *Single* concept scored the highest due to low complexity regarding the design and machinery, and requiring low maintenance. The criteria Spaciousness is the criteria which differ most between the concept, where the *Single* concept scored lowest due to its span width. The conclusion is that if the solution demands a compact solution there are other benefits with the *Single* concept. These four remaining concepts will be used in the further development of concepts.

4.5 Material and manufacturing

To narrow the design-space and not be constrained to evaluate all materials in the next iteration of the development phase, and evaluate those who are suitable for the application, a material selection was determined after the first iteration of principle concepts.

To investigate materials the method from the book Material Selection in Mechanical Design by Ashby [33] was utilised. The method entails several steps; the first is to derive the design requirements, the second is to screen the material with constraints, the third step is to rank the materials and last search for documentation to find specific materials within the groups along with other materials which can be utilised. To enable the screening in the second step, material indices were derived to minimise the mass and cost of the product. To be able to screen and rank the materials the material selection database ANSYS Granta Selector [35] was used.

Finally, linear static Finite Element Analysis was used to predict the minimum amount of material needed to manage deflection, implosion and predict if the material permanent deform when a force is applied. The analysis was conducted in ANSYS Mechanical [36]. By utilising the prediction, calculations regarding the cost of the material and appropriate manufacturing process could be conducted.

4.5.1 Design Requirements

To be able to find suitable material for the product, the design requirement for the product has to be specified [33]. The design requirements are derived because they are used in the future process; the constraints were used for the screening and ranking, see Section 4.5.3, and the objectives were used for the material indices, see Section 4.5.2. The free variables are variables to be substituted for, they have no restrictions regarding the product, see Table 4.4. The design requirements originate from the requirement specification; the function from requirement no. 1.8, the constraints from no. 2.3, 2.5, 2.7, 2.8, 2.9 and the objectives from no. 2.1 and 14.1, see Table 4.3.

Table 4.4: Design requirements for the product

Design Requirements	
Function	Generate a certain amount of lift force
Constraints	High stiffness High strength High corrosion resistance Handle operational and storage temp. of -35 to 80 degree Handle acid/alkali of pH 0-13 Handle UV radiation
Objectives	Minimise mass Minimise cost
Free variables	Wall thickness t in cross section Material selection

The derived design requirements originate from the situation that the material is to be used in an extreme environment, withstand saltwater and UV radiation along with cleaning using various chemicals. Since the function of the product is to generate a certain amount of lift force, the constraints include both high stiffness and strength. The constraints can be divided into hard and soft constraints, where the hard are the constraints which are valued the highest and the soft can be compromised to some extent, especially if the product is designed in a certain way. The first three constraints, high stiffness, strength and corrosion resistance, are considered hard constraints. When developing the product, low weight and a low cost is of interest, resulting in the objectives to minimise both the mass and the cost of the product whilst the wall thickness t and the material is free to alter.

4.5.2 Material Indices

To find suitable materials, material indices can be derived and maximised [33]. The indices are derived from the objectives in the previous section, see Section 4.5.1, and are used in the future screening and ranking, see Section 4.5.3, when deriving material charts in the materials selection database. The numerator and the denominator in the indices are used for the separate axis of the charts, and therefore of importance when searching for relevant material. The material indices are derived from the assumption of a cantilever beam with an evenly distributed force along the beam. This is similar to a foil which is fixed to a pod. The cross-section was chosen for a hollow ellipse since it is the shape most similar to a section profile, where the wall thickness t is the free variable for the product which is to be substituted for.

Minimise mass

The first objective is to minimise the mass, ensuring a limit of deflection is maintained and avoiding deformation when a force is applied to the foil, withstanding the force without entering the stage of plastic behaviour. The derivation can be seen in Appendix I and J, where the first indices are derived for a light stiff beam and the second is for a light strong beam. The material index for the stiffness, see equation 4.4, and the strength, see

equation 4.5, will be as follows:

$$M_1 = \left(\frac{E}{\rho} \right) \quad (4.4)$$

$$M_2 = \left(\frac{\sigma_y}{\rho} \right) \quad (4.5)$$

Minimise cost

The second objective is to minimise the cost, implying the material cost has to be minimised, this is done by using the objective function C dependent on the material price. The material price, C_m needs to be stated with the unit of SEK/kg to get the function, see equation 4.6 [33].

$$C = C_m m = C_m A L \rho \quad (4.6)$$

The material indices will change and for the stiffness, see equation 4.7, and for the strength, see equation 4.8, the equations will be as follows:

$$M_3 = \left(\frac{E}{C_m \rho} \right) \quad (4.7)$$

$$M_4 = \left(\frac{\sigma_y}{C_m \rho} \right) \quad (4.8)$$

4.5.3 Screening & Ranking

The materials selection database ANSYS Granta Selector [35] was used to screen material. The software contains three levels of data, where level 2 was used since it contains material groups rather than single materials, and because the materials in the same group have similar mechanical properties, making the screening less comprehensive. The screening was conducted by utilising the derived material indices together with the derived constraints, applied in the software. Utilising the index line in the created charts, where the exponentiation of the numerator in the indices will determine the incline of the line, material groups could be excluded, see the derived charts in Appendix K. The index line was used to pass on a manageable pool of materials, where the materials that scored highest on the material indices passed on. The material groups were ranked in regard to the material indices, where a high value possible is desired. Subsequently, the score of each material indices was summarised and a total ranking was achieved, see Table 4.5.

Table 4.5: Material data from level 2 [35]

Material data								
Material	E [GPa]	σ_y [MPa]	Price [$\frac{\text{sek}}{\text{m}^3}$]	$\frac{\sigma_y}{\rho}$	$\frac{E}{\rho}$	$\frac{\sigma_y}{\rho C_m}$	$\frac{E}{\rho C_m}$	Rank
CFRP	69-150	550-1050	551025	0,52	0,07	0,0015	0,0002	2
GFRP	21-21,8	207-304	94461 [76]	0,14	0,01	0,0027	0,0002	3
Stainless steel	190-210	257-1140	200079	0,09	0,03	0,0035	0,0010	1
Bronze	97-130	130-509	456019	0,04	0,01	0,0007	0,0002	7
Nickel	190-220	70-900	726313	0,05	0,02	0,0007	0,0003	5
Commercially pure titanium	100-105	276-360	635910	0,07	0,02	0,0005	0,0002	9
Nickel-chromium alloys	200-220	365-460	1121400	0,05	0,03	0,0004	0,0002	8
Nickel-based superalloys	200-220	273-900	1254420	0,07	0,03	0,0005	0,0002	6
Titanium alloys	110-120	763-1190	1085655	0,21	0,02	0,0009	0,0001	4

From level 2 passed 10 different material groups. The materials that passed the first screening were: two composite groups, carbon fibre reinforced polymer (CFRP) and glass fibre reinforced polymer (GFRP), bronze, which is on the pod today, stainless steel, pure nickel, pure titanium, and corresponding alloys. The material groups CFRP, GFRP, stainless steel and titanium alloys were ranked highest. However, titanium, and nickel, were excluded due to the standard STD 100-0005 [41], where Volvo Group list materials that are derived from the EU's list of Critical Raw Materials. The risk of using these materials can cause resource depletion and should be avoided if possible. This entails a further investigation of the three material groups at the top of the table. The price of GFRP was adjusted by a factor of 7 due to experts' opinions and other sources to suit the market value of today [76].

4.5.4 Candidate materials

External research was conducted to find specific materials, grades and alloys which are suitable for the component and can withstand the extreme environment, such as saltwater, UV radiation, and cleaning with various chemicals. Research provides the opportunity to narrow the wide material groups to find specific materials suitable for the concept and to find dismissed materials which can be utilised if the product is designed properly. By narrowing the material groups and choosing a specific material, predictions regarding implosion, stresses, and deflection, of one of the simpler principle concepts could be conducted. Further, it enabled a prediction of the wall thickness, inner structure and design of the concept.

Stainless steel

Stainless steel is corrosion-resistant, but exposure to an extraordinary environment, like saltwater, can result in corrosion of the material. Investigating the different materials within the group stainless steel shows grades within two different families, austenitic and duplex, suited for marine application handling saltwater preferable. In the austenitic family are the stainless steel 316, 317, and their derivatives. To increase the corrosion resistance against pitting, molybdenum is added, with a higher concentration in the latter [77]. During certain circumstances, a component made in stainless steel 316 needs to be galvanically protected due to crevice corrosion [78], which occurs at a crevice with a

stagnant solution at, for examples, attachments.

In the duplex family, suitable grades are for example 2205 and 2507. These grades are superior regarding corrosion resistance including crevice corrosion, higher Pitting Resistance Equivalent numbers (PREn) and up to 2.5 times higher yield strength compared to 316L [79]. However, the material price (SEK/kg) is higher than for both 316L and 317L [35]. Regarding PREn the aim is a number above 40 for stainless steel alloys, whereas the 316L and 317L have a PREn 25 resp 30 [80], and for many duplex grades, the number is around and above 40 [81].

Aluminium

Aluminium is a material that has been excluded since it was not classified with the highest resistance against corrosion in the material software [35]. There are however propellers and sterndrives made out of the material [82],[83], which makes it interesting to examine the possibilities of modification of the material and its suitability for foils. Aluminium is a low-cost low weight material and if the corrosion resistance is increased, with the suitable alloy, and the product design and material composition are concluded to prevent galvanic corrosion, aluminium can be used for the application.

Aluminium alloys can be divided into the groups wrought and cast aluminium alloys, where the former can be used in manufacturing processes like extrusion and the latter in various casting processes [84]. There are different designation systems for the two groups, and for wrought aluminium alloys the 5xxx- and 6xxx-series are preferred for marine application, Al-Mg alloys respectively Al-Mg-Si alloys, since their high corrosion-resistance capabilities. Regarding cast alloys the 4xx.x and 5xx.x is preferred for marine application, Al-Si respectively Al-Mg alloys. The latter is more difficult to cast, but its corrosion resistance surpasses the former [85],[86].

One of the used aluminium alloys for impellers is the aluminium 356.0, a cast alloy, which has sufficient properties regarding corrosion resistance and strength implying a suitable material for the application, even though it is not included in one of the groups mentioned above. The material resembles the alloy 6061, a wrought alloy with extraordinary corrosion resistance, which is utilised when workability is of importance. The material does not possess the highest strength but is suited for extrusion. If higher strength is needed other materials are more suitable, however, it deprives the workability [87],[88]. If a cast alloy for a marine application is to be used which possesses the same strength as 356.0, the choice is 518.0 [35], although it's harder to cast [86]. If the strength is compromised the 413.0 can suit the application.

Finite Element Analysis - Metals

A simplified model of the principal concept *Single* was used to determine the amount of material required for the product, whilst assuring a manageable deflection, and preventing implosion of the structure, of the foil. ANSYS Mechanical [36], a finite element analysis (FEA) software which uses the finite element method to numerically solve the differential equations, was used to anticipate this. The foil can be seen as a cantilever, as the side of

the foil has fixed support, and a total uniform distributed force is applied over the rest of the surface. Since only one foil is analysed, the force is represented by the lift force of $3750N$ upwards, negative x-axis, and the drag force of $200N$, negative z-axis, see Figure 4.22a. The drag force was derived from a single wing with a wing span of $1.4m$ and cord length $0.3m$, see Figure 4.16. It was a linear static analysis, and the applied material was an aluminium alloy 518.0 and stainless steel 317L.

If a $1mm$ stainless steel foil is used implosion will occur underneath the foil. The deflection is approximately $3,5mm$, see the red area in Figure 4.22b, and in total not considerable compared to the total thickness of the foil. However, if the speed of the boat or AoA of the foil is increased the deflection/implosion will increase, and the structure eventually fail. The implosion occurs with both the aluminium and the stainless steel with $1mm$ wall thickness.

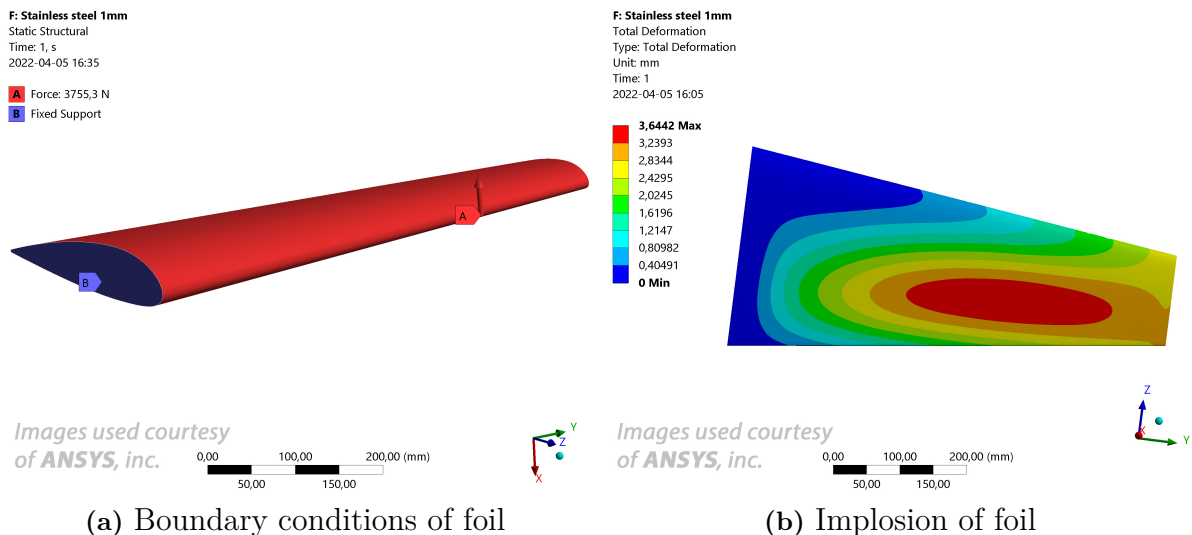

Figure 4.22: Set up and total deflection of first iteration

The deflection of the foil with the material stainless steel is $1,5mm$, see Figure 4.23a and aluminium alloy $4,5mm$, see Figure 4.23b, with a wall thickness of $2mm$. The desire is to assure a manageable deflection preventing the AoA of the foil to change during operation, or for it to create an unwanted fluid dynamic effect. The former can occur if the deflection is obliquely resulting in a twist of the foil. The safety factor of Equivalent (von-Mises) Stress for the foil in stainless steel is 1.903 and for the foil in aluminium 1.529 implying that the material will not reach the state of plastic deformation in both cases.

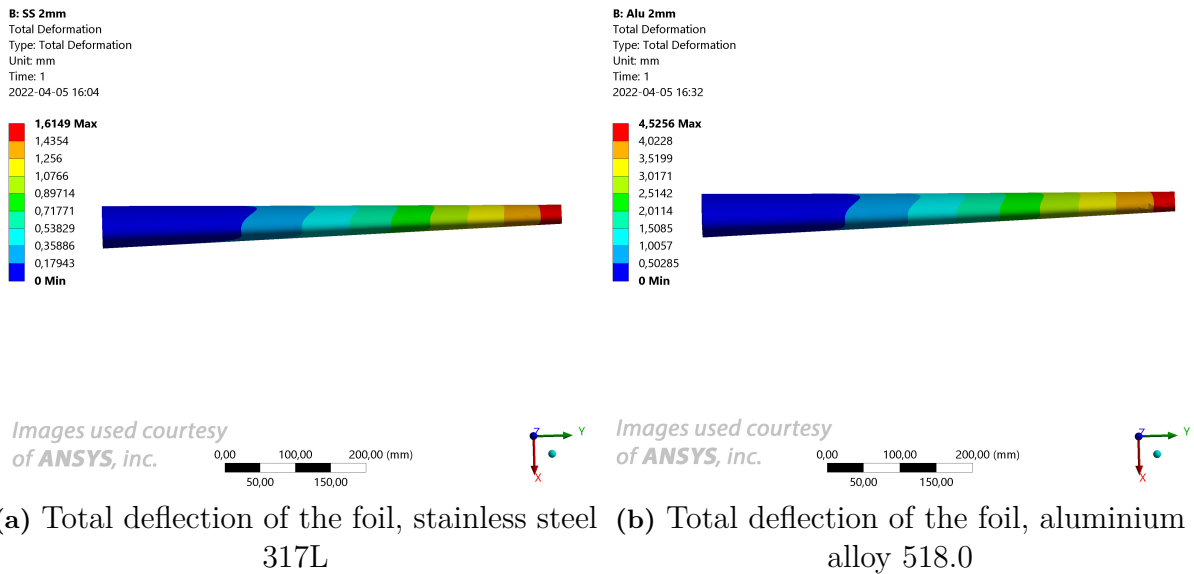

Figure 4.23: Total deflection of the foil with stainless steel and aluminium alloy

Since the force would not be uniformly distributed in a real case scenario, it would be smaller at the root and the tip of the foil, further calculations regarding how much the entire foil deflects needs to be conducted in future development. The pitching moment is assumed to be zero, which is an ideal state of reality, simplifying the calculations conducted, implying further calculations regarding the wall thickness or internal structure to prevent implosion. But with this elementary case, a modest deflection is shown with the chosen material and wall thickness. See further discussion in Section 7.2 future work and recommendations.

Polymers - Thermoplastics

An internal and external investigation of polymers used in subsea/marine applications was conducted to find other materials suitable for the component. Issues concerning finding a suitable polymer for the application are that they tend to have different properties regarding durability, such as resistance against alkalis and acids, which is one of the causes that polymers were dismissed in the first iteration, and handle external stress from the environment. An outer coating or if the polymer is chemically enhanced could solve different problems regarding durability. The data collected [89],[90] was cross-checked, and the materials found suitable were checked against the pyramid of polymeric materials to dismiss materials with low performance and strength [91]. The polymers analysed were semi-crystalline/crystalline thermoplastics, since they have these properties, together with a low friction coefficient and sufficient toughness [92], see Table 4.6.

Table 4.6: Material data from level 3 [35]

Material data								
Material	E [GPa]	σ_y [MPa]	Price [$\frac{sek}{m^3}$]	$\frac{\sigma_y}{\rho}$	$\frac{E}{\rho}$	$\frac{\sigma_y}{\rho C_m}$	$\frac{E}{\rho C_m}$	Rank
POM-C	2,9-3,2	57,2-71,7	17360	0,05	0,0021	0,0037	0,0002	1
PEEK	3,76-3,95	90-110	714605	0,08	0,0029	0,0001	0,0000	3
PA6	0,78-0,98	95-117	31736	0,10	0,0008	0,0033	0,0000	2

The passed materials were POM-C, PEEK and PA6 and analysed with the derived material indices. Since PEEK is expensive it performed lowest on these indices and therefore excluded. PA6 have a low Young's modulus, expands due to absorption of water [90], and was therefore discarded. The outcome was that POM-C is a suitable material for the application since it can withstand both weak alkalis and acids and if it is UV-stabilised it has properties to withstand external stress [35].

Finite Element Analysis - Thermoplastics

The deflection and if the material will permanent deform were predicted for POM-C with the FEA software [36]. The foil was designed with an internal structure since the stiffness and strength are lower than for metal, and the foil cannot be manufactured as a solid, see Section 4.5.5. The wall thickness was made 3mm, the inner structure 5mm, and the foil was stabilised even further with two shafts in stainless steel 316. Since the software is working with a student license there is a maximum of nodes and elements regarding the mesh, therefore this was the maximum inner structure made possible, see Figure 4.24a. A fixed support was applied to the cross-section of the two shafts, to lock all the degrees of freedom, and a bonded contact between the shaft and the structure to prevent any motion between the parts. Since only one foil is analysed, the force is represented by the lift force of 3750N upwards, negative x-axis, and the drag force of 200N, negative z-axis, see Figure 4.24b. The analysis was linear static.

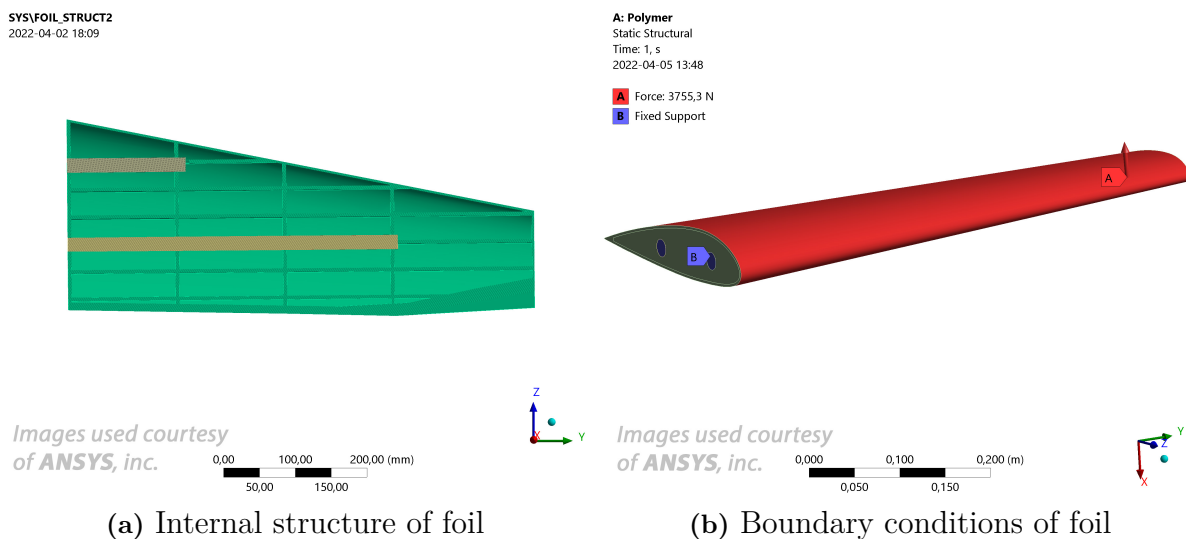
**Figure 4.24:** Set-up of the foil in thermoplastic

4. Development of hydrofoil concepts

Since the deflection with POM-C is about 35mm the choice was to test POM-C reinforced with 25% glass fibre. The result was a deflection under 20mm, see Figure 4.25b, since Young's modulus is 3 times higher for the reinforced material. The yield strength is twice as high, between 110 – 120MPa [35], implying that the material will not reach the state of plastic deformation, see Figure 4.25a. Further testing is required if 20mm is sufficient to not cause any damage to the foil or make it behave unwanted due to fluid dynamic effects.

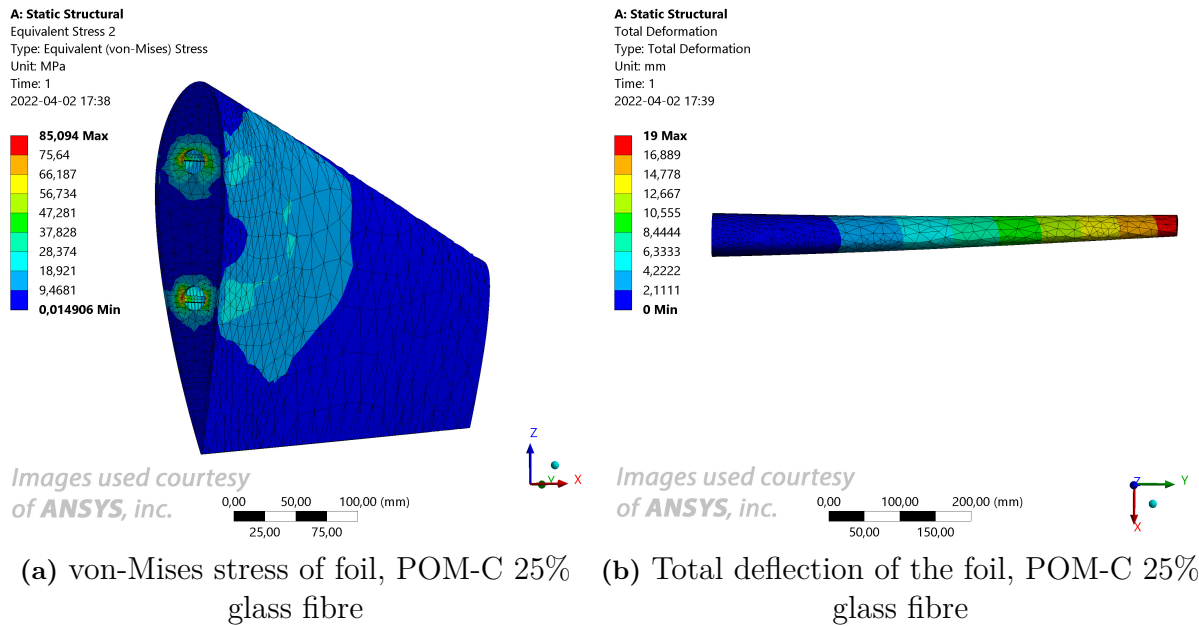

Figure 4.25: Stress and total deflection of the foil in reinforced POM-C

Thermoset composites - CFRP and GFRP

The specific materials in the material group for composites suggested in ANSYS Granta Selector were for CFRP an epoxy resin with continuous High Strength carbon fibre reinforcement in a quasi-isotropic layup. For the GFRP it was an epoxy resin with continuous E-glass fibre reinforcement in a quasi-isotropic layup [35]. The layup for the composites is lamina oriented in a 0, +45, 90-degree orientation. This is what characterises a quasi-isotropic layup with bidirectional (woven) fabric lamina, the difference in the orientation of the lamina to achieve the same strength and stiffness in all directions in one plane. Other orientations in the layups can be applied if unidirectional lamina is used. If the exact loads are determined, a quasi-isotropic layup will not be necessary for those areas where the load are not uniformly distributed in all directions. In this case 0- to 90- degrees layers can be used. This would decrease the cost of the laminate [93], and when designing the product in composites, this is an aspect to consider.

As resin for the matrix, polyester, vinyl ester, and epoxy are some of the materials which can be used. However, the mechanical properties, such as Young's modulus and tensile strength are higher for epoxy, implying it is more suitable since the number of lamina can be reduced, therefore reducing weight [76]. Typically prepregs, resin pre-impregnated

fabric, are used with epoxy, and prepreg is favourable regarding the strength/weight since it minimises the excess of resin which otherwise can be difficult to achieve. The part will be more accurate, regarding for example the thickness. However, the cost is higher [94].

Regarding corrosion resistance, composites are superior compared to metals, together with its high strength and stiffness. The loads on the foils are as seen in the previous calculations not exceptionally high, implying that glass fibre is a sufficient material for this application. It is more cost-efficient regarding material cost compared to carbon fibre [76]. If woven prepreg as lamina is chosen for the CFRP and GFRP, Young's modulus of GFRP is only half of the selected CFRP, and the stiffness is around twice of reinforced POM-C [35], implying that the total deflection can be kept to a minimum if designed properly. If inquired, the stiffness of GFRP can be increased by adding layers of carbon fibres lamina [76].

Regarding the recycle fraction for thermosets composite it is low or none [35], some alternative fibres were looked upon to investigate if the fibre reinforced polymer (FRP) could be made more environmentally friendly. One fibre used in various applications is flax fibres, which has a lower kg CO_2 /kg fibre equal to carbon fibre [95]. However, one of the downsides of using flax fibres in a marine application, in water, is that it tends to absorb water when exposed, which will decrease the mechanical properties [96]. If the foil is to be protected by impact protection or diverse shell to narrow the risk of damage and delamination, various unconventional fibres can be used.

4.5.5 Cost & Manufacturing processes

An investigation regarding appropriate manufacturing processes, complying with a production volume of around 2000 pieces, and a cost estimation was conducted, to find suitable processes enabling high freedom in design if the foil for a reasonable cost, see requirement no. 14.1 in Table 4.3. The investigation and estimation were conducted with the software ANSYS Granta Selector and Process Selection: From Design to Manufacture by Swift and Booker [35], [34]. Specific materials were chosen for each group of materials since some of the materials only can be used with a specific manufacturing process. Regarding the manufacturing cost of components designed in composite, it was discussed with domain experts at composite manufacturing companies, and adjusted accordingly.

When calculating the cost, the volume of the product used was acquired from the CAD models used in the previous section, and 20% volume was added for attachments and infill. The cost is the mean of a range visualised in the software, implying increased deviation of certain manufacturing processes. Included in the software is the Capital Write of time set to 5 years, the Discount range to 5%, the Load factor to 0,5 and the Overhead rate to 1330 SEK/h for all manufacturing processes. Discluded from the cost are freight, post-processes, and assembly costs. The cost estimation was conducted on the *Single* concept, for one foil on one side of the pod, and the result will differ for concepts with more complex shapes since it is not accounted for in the software.

Aluminium & Stainless Steel

For aluminium alloys and stainless steel, a group of appropriate materials was chosen, enabling cost calculations regarding manufacturing processes. For aluminium alloy, including materials such as 518.0 and 6061, five different manufacturing processes were investigated; hydroforming process, superplastic forming, powder metallurgy, continuous extrusion, and gravity die casting, see Figure 4.26. The two forming processes require one die for each sheet, for this type of concept it would require one upper and lower part, and two endplates. Additionally to this, a process to assemble the parts and attach a shaft in-between to enable rotation of the foil, like welding, would be necessary. This cost is not included in the calculation. Further, superplastic forming is expensive since it is preferred for higher economic batch sizes than 2000 pieces a year. Powder metallurgy generates pores in the material that allows bacteria to thrive, leading to increased biofouling, and the wall thickness to length ratio is out of scope for the component to suit the process [34]. These manufacturing processes are therefore not suitable for the application.

If the foils are to be manufactured at a lower cost, continuous extrusion is the choice as the production rate is high and the manufacturing cost is low. The method enables a complex cross-section, implying the design to facilitate attachment of the shaft. Two endplates are still required to be manufactured and welded/attached to the foil, but far fewer parts than for the forming processes mentioned above. The downside is that the planform is to be rectangular, which will decrease the efficiency of the foil. As for casting, gravity die is an appropriate choice since its low surface roughness compared to other casting processes, enabling decreased cost of post-processing. With casting, the two parts can be manufactured with half of the endplates at each part together with a structure to attach the shaft, minimising welding. This method enables higher freedom in design but at a higher cost compared to continuous extrusion.

Material group		Metal									
Specific material		Aluminum; 6061 and 518.0					Stainless steel; 317L				
Description	Unit	Hydro-forming process	Gravity Die Casting	Super-plastic forming	Powder metallurgy	Continuous extrusion	Investment Casting	Super-plastic forming	Powder metallurgy	Continuous extrusion	Sheet metal forming
Wall thickness	mm	2	2	2	2	2	2	2	2	2	3
Density	kg/m ³	2710	2685	2710	2710	2710	7970	7970	7970	7970	7970
Material cost	SEK/kg	18	18	18	18	18	37	37	37	37	37
Volume product	m ³	6,56E-04	6,56E-04	6,56E-04	6,56E-04	6,56E-04	6,56E-04	6,56E-04	6,56E-04	9,06E-04	6,56E-04
Volume attachment, infill	m ³	1,31E-04	1,31E-04	1,31E-04	1,31E-04	1,31E-04	1,31E-04	1,31E-04	1,31E-04	1,81E-04	1,31E-04
Product weight	kg	2,1	2,1	2,1	2,1	2,1	6,3	6,3	6,3	8,7	6,3
Material cost/product	SEK/unit	39	39	39	39	39	229	229	229	317	229
Manufacturing cost/product	SEK/unit	153	260	1700	300	70	375	1775	375	185	1375
Total manufacturing cost	SEK/unit	305	520	3400	600	70	750	3550	750	185	2750

Figure 4.26: Cost for material and manufacturing processes

For stainless steel, such as 317L, many of the conclusions regarding superplastic forming and powder metallurgy for aluminium applies. Regarding sheet metal forming it is suited for higher batch sizes and requires several parts to be assembled, and therefore discarded as for the rest of the forming processes. Continuous extrusion is an option for stainless steel if the wall thickness is at least 3mm. This will add material implying an over-dimension of the component regarding strength. Casting is another suitable manufacturing process

for this material. For this application, investment casting is applicable for the material since it can handle complex geometries. When choosing between the continuous extrusion and investment casting, it comes down to what is more important, the cost or efficiency of the foil. Casting will give more freedom in design, but extrusion will probably be cheaper. An advantage of producing the foils in stainless steel is that the shaft is made of stainless steel, enabling attachment is less complex regarding corrosion.

Thermoplastic & Thermoset Composites

To be able to manufacture the foils in the thermoplastic polymer POM-C, reinforced with 25% glass fibre, two processes were appropriate, compression moulding and injection moulding since both can manage fibre reinforced polymer. For POM-C the maximum wall thickness is approximate 3mm , limiting the design of the concept, but with long fibres, it can be increased [97], which may be applied in this case. Injection moulding is recommended for complex shapes, dismissing compression moulding as a manufacturing process since the foil requires an inner structure not to deflect extensively.

Material group		Thermoplastic and Thermoset Composites							
Specific material		Reinforced POM-C 25% Glass fiber		Epoxy - HS carbon fiber; woven prepreg and resin infused fabric OI-layup			Epoxy - E-Glass; woven prepreg and resin infused fabric QI-layup		
Description	Unit	Injection moulding	Compression moulding	Autoclave moulding	RTM	SMC	Autoclave moulding	RTM	SMC
Wall thickness	mm	3	3	2	2	2	3	3	3
Density	kg/m ³	1595	1595	1575	1575	1575	1860	1860	1860
Material cost	SEK/kg	24	24	494	168	494	71	71	71
Volume product	m ³	1,48E-03	1,48E-03	6,56E-04	6,56E-04	6,56E-04	9,06E-04	9,06E-04	9,06E-04
Volume attachment, infill	m ³	2,96E-04	2,96E-04	1,31E-04	1,31E-04	1,31E-04	1,81E-04	1,81E-04	1,81E-04
Product weight	kg	2,8	2,8	1,2	1,2	1,2	2,0	2,0	2,0
Material cost/product	SEK/unit	67	67	611	208	611	143	143	143
Manufacturing cost/product	SEK/unit	285	170	6250	950	1000	5750	875	600
Total manufacturing cost	SEK/unit	570	340	6250	1900	2000	5850	1850	1300

Figure 4.27: Cost for material and manufacturing processes

Investigation regarding manufacturing processes of foils made in thermoset composites, such as Epoxy/HS carbon fibre with a quasi-isotropic layup and Epoxy/HS carbon fibre with a quasi-isotropic layup, resulted in three different methods. The methods were; autoclave moulding, resin transfer moulding (RTM) and sheet moulding compound (SMC). For the calculations, a prepreg was chosen for the autoclave and SMC, and a woven fabric for the RTM. An assumption made for the thickness was made, 2mm for the CFRP, and 3mm for GFRP, because of its mechanical properties regarding stiffness and strength.

The calculated cost to produce the *Single* concept in RTM or SMC is the cost for two sheets of composites, see Figure 4.27. The material software only allows for simpler manufacturing processes, and to be able to manufacture the *Single* concept more refined processes, further referred to as combined process, are required. The process Bladder assisted RTM is an option since it combines two processes and allows an internal structure [98]. The realistic cost would by that be higher than the calculated cost, see Figure 4.27.

Regarding assembly of a shaft and the thermoset composites, further investigation is required, but it is possible to glue a stainless steel shaft with a thermoset composite if the friction between the components are enhanced, with for example a pattern implemented on the shaft. Considering autoclave, the possibilities are higher regarding including the shaft in beforehand of the process. Autoclave as a manufacturing process is expensive, enabling high investment costs, but the accuracy and quality of the produced product surpass many other manufacturing methods for composites since prepreg is used. The overall cost to manufacture the part in thermoset composites is higher compared to the other manufacturing processes, which mainly depends on the complexity of creating parts in thermoset composites, and difficulties to automatise the process [99].

4.5.6 Conclusion of material & Environmental aspects

A conclusion regarding the chosen materials and their properties was conducted together with an evaluation regarding their environmental aspects. In addition, the material was compiled in a table with the derived material indices to rank them accordingly to their specific mechanical properties and price, see Table 4.7.

Table 4.7: Material data for remaining materials from level 3 [35]

Material data								
Material	E [GPa]	σ_y [MPa]	Price [$\frac{sek}{m^3}$]	$\frac{\sigma_y}{\rho}$	$\frac{E}{\rho}$	$\frac{\sigma_y}{\rho C_m}$	$\frac{E}{\rho C_m}$	Rank
Epoxy/HS carbon fibre w. prepreg. Ql lay-up	44,2-48,2	450-649	777262	0,35	0,0293	0,0007	0,0001	2
Epoxy/E-glass fibre w. prepreg. Ql lay-up	21-21,8	207-304	183582 [76]	0,14	0,0115	0,0019	0,0002	3
Stainless steel 317L	196-204	195-262	291702	0,03	0,0251	0,0008	0,0007	5
Aluminium 518.0	69,6-72,4	177-195	49135	0,07	0,0264	0,0038	0,0014	1
Fibre reinforced POM-C	8,62-9,65	110-120	37482	0,07	0,0057	0,0031	0,0002	3

Aluminium has advantages over stainless steel regarding both density and cost. Stainless steel has advantages regarding its corrosion resistance and stiffness. Since the problems regarding corrosion can be solved for aluminium alloy this would be the suitable material when comparing the metals, if not the pod is made out of stainless steel. Suggested is to do the foils in the same material as the pod when it comes to metals, implying stainless steel as a second option to aluminium.

Regarding the overall price of the foil, reinforced thermoplastic and aluminium are among the highest-ranked materials. The downside of reinforced POM-C is that it is not recyclable, only downgraded, and therefore the material has lower mechanical properties than initial implying only usage in applications requiring this [35]. The upside of aluminium is that it is recyclable, decreasing the environmental impact. Foils manufactured in POM-C require less post-processing than foils manufactured in aluminium, implying less cost and a comprehensive advantage. Regarding corrosion, it does not require protection, which is necessary for aluminium.

Concerning thermosets composites the choice is the E-Glass fibre as the price of carbon fibre does not justify the mechanical properties for this application. Due to environmental aspects, and limitations regarding recyclability, along with the total cost for manufacturing, thermoset composites are the option when the foil acquires a complex shape and where the other materials lack freedom in design regarding manufacturing processes and

mechanical properties. If high freedom in design is not required, the two other materials are more suitable.

4.6 Further development of concepts

The further development of concepts is the last part of the core development process, generating sub-solution upon the sub-functions, and allocating the result into morphological matrices. Synthesising and refining principle concepts upon the sub-solutions, and discarding sub-solution concerning each principle concept, narrowing the design-space. The second concept scoring evaluates and compares all the remaining refined concepts, enabling four refined concepts as an outcome.

4.6.1 Second loop idea-generation and evaluation

To ensure a thoroughly explored design-space the principle concepts were divided accordingly to the sub-functions in the function tree and the sub-solutions were derived, to generate more detailed and refined concepts. A brainstorming was conducted to find further sub-solutions to all sub-function utilising a Morphological matrix as a bookkeeping tool [22].

The matrix contains 12 sub-functions with corresponding sub-solutions, see Figure 4.28 and 4.29, which was generated by a brainstorming. The coloured rows contain part solutions to sub-solutions, where the part solutions are not evaluated in this project but included to account for the different possibilities, are equally in their performance or are case-specific. Several sub-solutions to the functions were excluded before synthesising concepts, squares in pink colour, due to minimising and refining the design-space and creating concepts with higher feasibility. In this part of the Morphological matrix, ten sub-solutions were discarded.

4. Development of hydrofoil concepts

Functions	Sub-functions	Sub-solutions							
		1	2	3	4	5	6	7	
Generate lift in a comfortable manner	A	Induce lift	Elliptical lifting line planforms A1	Hershey-bar (straight) A2					
			Elliptic/half elliptic A1.1	Straight Tapered planform A1.2	Schuemann A1.3				
	B	Allocating lift area		Straight single foil B1	Straight multiple foils B2	Continuous foil B3			
				Biplane B2.1	Tandem B2.2				
				Round B3.1	Elliptical B3.2	U- shaped B3.3			
	C	Prevent cavitation	Adjustable AoA by rotating foil C1	Cavitation plate C2					
	D	Control stall	Adjust AoA by rotating foil D1	Multiple profile sections D2	Wash-out (twist) D3	Wing fences D4	Slight swept tapered planform D5	Vortex generators D6	Wash-in (twist) D7
	E	Control lift	Adjust AoA by rotating foil E1	Extendable foils with linear activators E2	Increase chord length with Slats E3	Adjust span-width by adjusting the sweep of the wing E4	Adjust span-width by adjusting the dihedral of the wing E5	Inflatable sections of wing E6	Adjust AoA with Flaps E7

Figure 4.28: Part one of the Morphological Matrix

For the sub-function *Prevent cavitation* one sub-solution was a cavitation plate, commonly used above the propellers to prevent cavitation. This solution will cause extra drag due to the additional wetted surface, and the net efficiency is uncertain. The sub-solution Wing fences and Vortex generators to the sub-function *Control Stall* were partly dismissed due to the increase in biofouling and maintenance for the user. There is no necessity for vortex generators as these delay separation at high operating AoA, which the product is not expected to experience. To control the stall characteristics, a slightly swept tapered planform is a solution, but a reduction of the area will be achieved and therefore a decrease in lift force. Wash-in was dismissed due to it enabling the tip of the foil to stall before the root of the foil, implying that the vessel will be sensitive to rolling motion as the lift decreases at the tip of the foil first.

To *Control lift* the foils can be swept back and forward or adjust the dihedral of the foil during operation. These are two sub-solutions which are complex and difficult to make feasible without leaking water into the pod. The complexity and feasibility also apply to the inflatable sections of the foil, making them longer as more lift is required. Increasing the area with slats is one solution, but due to the complexity of machinery and biofouling this solution was eliminated.

Adjusting AoA with flaps is eliminated due to flaps as a solution is to control and redirect the vessel's AoA, not only the foils, which may imply a counteracting behaviour. Decreasing the AoA of the hull seems to entail benefits regarding efficiency, achieved by increasing the lift and AoA of the foil, implying that the hull's AoA has to be decreased as the AoA of the foil has to be increased. If flaps are to be used, the foil has to have rotational freedom, allowing the foil's AoA to be adjusted independently of the hull.

Enable Serviceability	F	Handle corrosion and applied forces during operation	Composite (CFRP/GFRP) F1	Polymers F2	Metal F3				
			Aluminium+anod F3.1	Stainless steel F3.2					
	G	Decrease and ease of cleaning	Lift out of water G1	Anti-fouling G2					
			Ultra sound G2.1	Finsulate G2.2	Paint G2.3	Silicon wrap G2.4	UV light source G2.5		
	H	Modularisation/ ease of changing parts	Bolted/mounted from outside H1	Bolted from inside of pod H2	Interference fit H3				
			Bayonet mount H1.1	Threaded shaft with lock nut H1.2					
Provide a safe ride for the user	I	Insensitive to debris entanglement	Sweep back LE I1	Design without inner corners, (ex fillets/fairings) I2	Air pressure (through holes) I3	Razor blades at the LE/stagnation point I4			
	J	Ensure integrity of hull at impact	Crack initiation (foil+pod break before interface) J1	Make foil structure weaker than pod J2					
	K	Counteract propulsion motor torque (anti-torque)	Change shape of pod K1	Adjustable pod (Angled pod legs) K2	NOTAR technology (water instead) K3	Twist wing to create moment K4	Fenestron/open tail rotor K5		
			Edge (interceptor) on pod K1.1	Asymmetric profile on pod K1.2	Add skeg to the pod K1.3				
L	Prevent jack-knifing	Rotation center in front of center of pressure L1	Fixed installation L2						

Figure 4.29: Part two of the Morphological Matrix

In the second part of the Morphological matrix four sub-solutions were dismissed. For the sub-function *Insensitive to debris entanglement* one sub-solution was to use air pressure to blow the debris away, but since one criteria is to minimise the complexity of the product this was dismissed. The razor blade sub-solution may not be safe enough for the user and therefore discarded.

For the sub-function *Counteract motor torque* solutions used on helicopters were looked upon. The Fenestron/open tail rotor is one solution used, but in this case, got discarded due to complexity and may add extra maintenance due to biofouling if not the product is lifted out of water. The NOTAR technology is also a solution used on helicopters and can be implemented on the pod, but instead of using air, the solution is to use water, redirecting the stream with an outlet the end of the pod, generating a moment. The sub-solutions which passed on will be discussed further in the next section.

4.6.2 Concept synthesis & Evaluation

This section addresses the synthesis of new principle concepts, concluding the sub-solutions in morphological matrices, and evaluating the refined concepts. Conducting cost estimation regarding material and manufacturing processes, and a risk assessments of all refined concepts, enabling the scoring to be thoroughly conducted. The sub-solutions of each principle concept was evaluated to decrease the design-space and generate refined concepts.

Concepts synthesis

A new principle concept was composed upon the sub-solution generated in the second brainstorming. The concept adjusts the generated lift force by adjusting the width of the foils through linear motion, increasing the lift by extending the span width, and thus the lift area. Implementing linear activators into the foil allows the foil to be manufactured as separate product, or including the inner part into the design and manufacturing of the pod, see Figure 4.30. The feature implies a compact concept when operating the boat in harbours and managing it on shore, maintain the same opportunity of lift as the *Single* concept. Further, the concept does not allow any sufficient wash-out to be utilised to control the stall characteristics, instead the foil can be modified with wing fences ensuring the section of the foil does not stall at once, see Section 4.3.2. The concept acquires a pre-determined AoA, implying that the foils will always generated lift during operation as the width will never be zero.

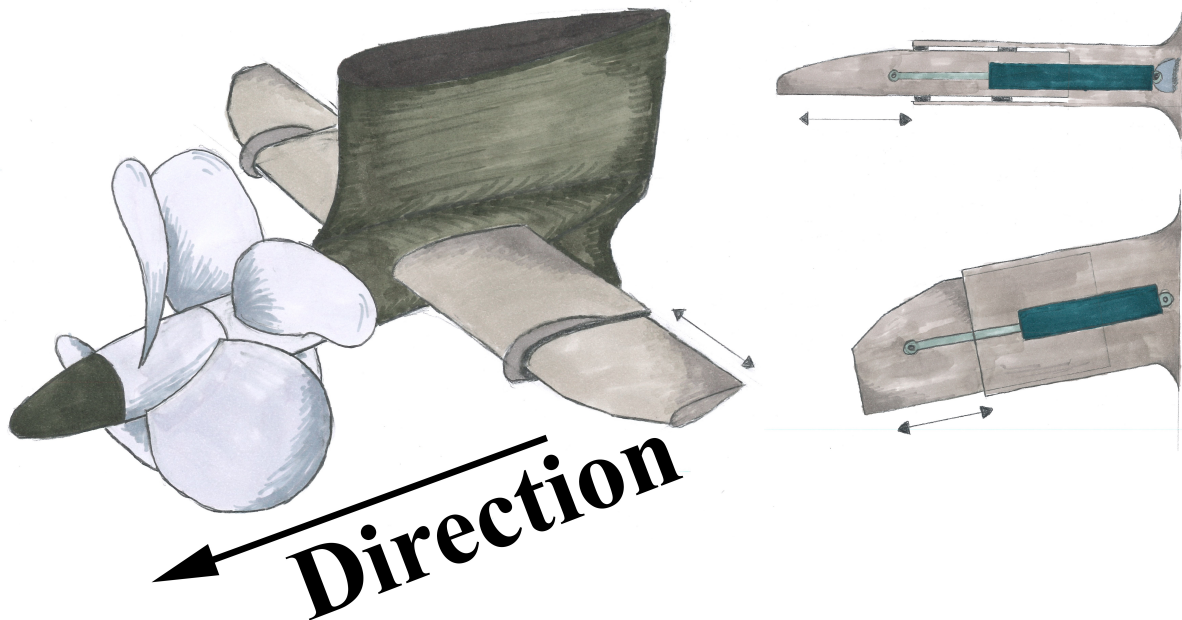

Figure 4.30: Visualisation of the principle concept *Telescopic*

Evaluation of Manufacturing cost

A material and manufacturing processes cost evaluation using ANSYS Granta Selector was conducted on the refined concepts to be able to use the information in future scoring and evaluation of the concepts [35]. The cost estimations was conducted in regard to all foil implemented on the pod, the pod not included in the calculations, with the appropriate material for each concept, see earlier evaluation in Section 4.5.6. The full calculations on the cost for the concepts can be seen in Appendix Q, whereas parts of it can be seen in Table 4.8 below.

Table 4.8: Manufacturing cost for each concept

Cost of each concept					
Description	Unit	<i>Odd Dual & Odd Berit</i>	<i>Comes Around</i>	<i>Telescopic</i>	<i>Single</i>
Material	[-]	Reinforced POM-C	E-Glass fibre	Reinforced POM-C Aluminium	Reinforced POM- C
Manufacturing process	[-]	Injection Moulding	Autoclave	Injection Moulding/ Gravity die Cast	Injection Moulding
Wall thickness	[mm]	3	3	2/3	3
Weight of concept	[kg/unit]	5,48	8,1	5,1	5,67
Material cost	[sek/unit]	131	570	104	136
Manufacturing cost	[sek/unit]	2280	11350	2020	1150

For the *Single*, *Odd Dual* and *Odd Berit* concept the determined material was reinforced POM-C, since the overall cost is estimated to be the lowest for that material and because it has sufficient mechanical properties, see former Section 4.5.6. The material for the not rotatable part of the foil in the *Telescopic* concept was chosen to aluminium 518.0 and reinforced POM-C for the translation part of the foil, see Section 4.5.6. As addressed in Section 4.5.6, when a complex shape is required, thermosets composites are the option, enabling E-Glass fibre set as material for the *Comes Around*.

The wall thickness for the *Comes Around* was determined to 3mm for the E-glass fibre composite. It may be an overestimation for the shell, but since the concept is of one piece it might require some internal structure and therefore require extra material to prevent deflection. This concept is the most expensive to manufacture, due to material cost, complex shape and required manufacturing process. The concepts made in a polymer are the most cost-efficient, whereas the *Single* concept has the lowest manufacturing cost. This is due to the other concepts in polymer contains more parts, enabling for a higher cost.

Evaluation of Synthesised concepts

Five different morphological matrices were concluded when synthesising more refined concepts, one for each principal concept. Further sub-solutions were dismissed to decrease the design-space, and colour-coded for simplification. Red represents solutions which are not applicable for the specific concept group and yellow is not suitable for the concept. Grey is solutions constrained to the specific concept group since these sub-solutions distinguish the concept. What was left creates certain configurations of concepts which are case-specific, therefore dependent on each user situation, for an overview see Figure 4.31.

Further elimination of sub-solutions in Morphological matrices

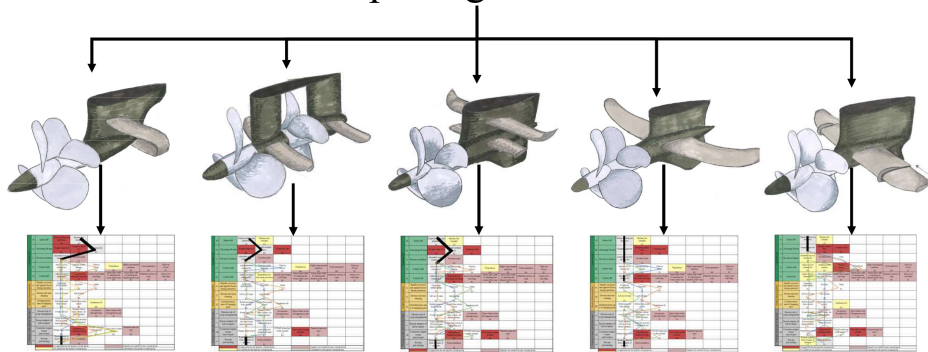

Figure 4.31: Overview of the refined Morphological matrices

For the *Single* concept the Hershey-bar planform was excluded since it is the least effective of the remaining planforms, see Appendix L. The Hershey-bar is only used for *Comes Around* due to its shape. The option of lifting the concept out of the water is a solution not suitable due to the concept's spaciousness. Wing fences are only used for the *Telescopic* concept and not used in any of the other concepts since they have been allocated with other more suitable solutions. Regarding material, the foils are preferably made in a reinforced POM-C, using a weaker structure to ensure the integrity of the hull at impact, and if the pod is made out of metal, it is preferable to use a crack initiation as a solution.

To control stall for the *Single* concept it is advantageous to adjust the AoA in combination with solutions such as multiple section profiles or wash-out. Since the pod is not squared and rotatable it is difficult to use a rounded inner corner, preferably using a swept-back leading edge to decrease debris entanglement. If the foils are to be changed numerous times during its service life, the interference fit is not desirable since it is a complicated process. To create an anti-torque the shape of the pod could be altered or using the NOTAR technology, however, the latter is an untested solution.

The concept *Odd Dual* enables the sub-solution lifted out of the water since the concept is not spacious, see Appendix M, otherwise similar sub-solutions as to the *Single* concept are used. Similar applies for the concept *Odd Berit*, except for the adjustable pod/angled pod legs to create anti-torque, which is distinguished for this concept, see Appendix O. Since the concept already is complex, the NOTAR system would add extra complexity, and altering the shape of the pod is instead preferable.

As *Comes Around* is made in a thermoset composite, it does not enable a crack initiation to ensure the integrity of the hull at impact since it is not compatible with the material, see Appendix N. To control stall the AoA is adjusted, and the solution is preferably used with the other solutions such as using multiple section profiles and wash-out. To decrease cleaning it can be lifted out of water due to its smaller size, or used with an anti-fouling system. The design facilitates the sides of the foils to be twisted to counteract the propulsion motor torque, and it is the only concept that possesses this feature. If it is

not manufactured with this design, the pod's shape can be altered or NOTAR used. To decrease the risk of scrap entanglement the leading edge is preferably swept back, enabling rounded corners as fillet/fairings are difficult due to the concept's ability to rotate. An interference fit to empower modularisation is more complex for this concept since both sides need to be attached at once, implying the other solutions such as bolted/mounted from outside/inside of the pod are more suitable.

The *Telescopic* has no solution to prevent cavitation since the first part of the foil is fixed to the pod, either by bolts from inside/outside of the pod, or manufactured as one piece with the pod, see Appendix P, but as mentioned the angle of operation for the foil is predefined to a few degrees. If the foils are to be able to rotate it would be considered a highly innovative solution, but this would result in a higher complexity to an already complex concept, therefore are these solutions marked as not suitable. The concept can advantageous both be lifted out of water since it can decrease its size or use an anti-foiling system if not lifted. Regarding the design, it is beneficial to sweep back the leading edge and have rounded corners as fillets/fairings to decrease the debris entanglement, as the inner part is fixated to the pod. Since the fixed part is made out of metal the optimal solution to ensure the integrity of the hull at impact is a crack initiation, however, if all the parts are made out of POM-C the solution is to make the foil structure weaker than the pod. To counteract motor torque the shape of the can be altered or use NOTAR.

Risk assessment

To be able to do a risk assessment, and use it in future scoring, a failure mode, effects, and critically analysis (FMECA) was conducted on the five remaining concepts [100]. An FMECA is a tool where the failure mode is listed and its effects are reviewed. One of the outcomes is to gain knowledge which can be used in the further development of the concepts. The severity, occurrence, and detection of the failure modes were ranked accordingly and multiplied to get the Risk Priority Number (RPN) [101]. The failure modes are only evaluated for the foils/pod and the interference between, implying the interaction between the pod/hull is not considered. The most critical failure modes can be seen in Table 4.9, whilst the rest can be seen in Appendix R.

Table 4.9: Most critical failure modes

<i>Singel</i> concept							
Potential Failure mode	Potential Failure Effects	S.	Potential Causes	O.	Current Controls	D.	RPN
Underwater noise	Harming maritime life → no op. in certain environments	7	Hydrodynamic effects	4	Test, simulation	9	252
Biofouling (E.g. barnacles)	Increase drag (less efficiency)	5	Pores leading to bacteria	8	Minimise pores, utilise anti-fouling solutions	5	200
Cavitation	Noise during op. and unwanted erosion	4	To high speed/ dynamic effects during op.	7	Physical testing	6	168
Debris entanglement	Increase drag (less efficiency), loses all the propulsion	8	Insufficient geometrical design	4	Physical testing/ sufficient geometrical design	4	128

The failure mode Underwater noise is high throughout all the concepts. This is because if the regulations regarding underwater noise change and regulations regarding noise levels are applied to certain areas, operation may be forbidden within certain areas if the concept is considered to surpass the limit. This will cause a low degree of customer satisfaction. Failure modes such as Cavitation, Debris entanglement and Biofouling are also

constantly high among the concepts. This is because these are some of the main obstacles to be solved regarding propulsion system operation in water and subsea environment, and these failure modes are difficult to detect.

The concept that scored the highest RPN was *Odd Berit* since it has an innovative complex design, and possesses problems which need further development. For instance, it has a more complex system to control than for example the *Single* concept, and uncertainty regarding unwanted hydrodynamics effect due to the placements of the foil, needing further testing to assure its effects. Its scores resembles to *Comes Around* and *Odd Dual* since the concept also have complex designs. The *Single* scored the lowest RPN since it is a proven product in the industry and does not include too many complex parts or advanced design which can create failure regarding system controls or unwanted hydrodynamic effects.

4.6.3 Second Concept scoring

The five refined concept was scored and ranked accordingly, using a Kesselring matrix with refined criteria, and thereafter evaluated. The concept catalogue are created on the the four remaining concepts, see Chapter 5.

Kesselring matrix - Second iteration

A second concept scoring was conducted on the refined concepts with the outcome to have four remaining concepts for the concept catalogue, by using a Kesselring matrix, see Figure 4.32. The criteria used for the Kesselring matrix were modified since new information regarding the component's material and weight, and results from the risk assessment had been calculated. Because of this, subjective values were added to the Subjective and objective Values matrix and the Pairwise Comparison Matrix was revalued, see Appendix S and T. The limits for the criteria Efficiency and Spaciousness had been decreased in this Kesselring matrix to be able to distinguish the concepts. These, together with the criteria of User satisfaction and Risk assessment have the highest weight factor.

Kesselring matrix													
Criteria		Solution alternative											
		Ideal		A Single		E Comes Around		G: Odd Dual		H: Odd Berit		I Telescopic	
Name	W	v	t	v	t	v	t	v	t	v	t	v	t
Efficiency (L/D)	0,136	5	0,68	3	0,41	4	0,55	3	0,41	2	0,27	2	0,27
Spaciousness	0,118	5	0,59	1	0,12	4	0,47	3	0,35	2	0,24	3	0,35
Manufacturing complexity/specialization/cost	0,100	5	0,50	5	0,50	1	0,10	3	0,30	2	0,20	3	0,30
Weight of component	0,064	5	0,32	5	0,32	1	0,06	5	0,32	5	0,32	5	0,32
Complexity/increased capability of machinery	0,045	5	0,23	4	0,18	2	0,09	5	0,23	4	0,18	3	0,14
Maintenance required (company/service)	0,073	5	0,36	4	0,29	3	0,22	3	0,22	1	0,07	2	0,15
Technical feasibility (TRL)	0,000	5	0,00	0	0,00	0	0,00	0	0,00	0	0,00	0	0,00
Risk for debris entanglement	0,055	5	0,27	4	0,22	3	0,16	3	0,16	1	0,05	2	0,11
User satisfaction	0,145	5	0,73	4	0,58	5	0,73	3	0,44	3	0,44	3	0,44
Risk assessment (FMECA)	0,182	5	0,91	5	0,91	3	0,55	3	0,55	1	0,18	3	0,55
Innovation	0,082	5	0,41	1	0,08	4	0,33	3	0,25	5	0,41	4	0,33
T=Σ ti		5,00		3,61		3,25		3,22		2,36		2,95	
T/Tmax		1		0,72		0,65		0,64		0,47		0,59	
Standard deviation		0		1,47		1,26		0,69		1,37		0,89	
Number of weak points		0		2		3		0		6		3	
Ranking				1		2		3		5		4	
Decision		1-4 will progress to the concept catalogue											

Figure 4.32: Evaluation of the refined concepts with a Kesselring matrix

The conclusion from the Kesselring matrix is that *Berit* performed the lowest score with plentiful weak points. This is due to the complex design, it has a high risk of enabling debris entanglement, the concept is broad/wide when including the pod and scored low on the risk assessment. This is however the most innovative concept, but it is not sufficient to outweigh the other criteria. The *Telescopic* is the second concept with plentiful weak points. This is mainly due to poor efficiency, AR becomes low when it decreases its lift and length, it is heavy and might cluster debris due to its special features as winglets and endplates.

The most robust concept is the *Odd Dual*, due to its fairly complex design and complexity of machinery. It has no weak points, compare to the *Single* concept. In this Kesselring matrix, it is the concept that scored highest. This is mainly due to its simplicity which does not require complex machinery or maintenance. However, due to its well-known design on the market, it scores low on the innovation criteria. It still has a large span width which decreases the score in the Spaciousness criteria. This is one of the criteria the *Comes Around* scored highest on, together with efficiency and innovation, since it is compact and has a new design not implemented on the market when it comes to hydrofoils.

4.7 Validation of concepts

This section includes the requirements verification, verifying the fulfilment of the requirement specification, and addressing how certain requirements can be verified. The validation of hull efficiency, concludes the implementation of the developed concept into the Savitsky method, ensuring and addressing the positive aspects of doing so.

4.7.1 Requirement verification

The four remaining concepts were verified against the requirements and desires in the requirement specification to analyse which are evaluated or not, or require further evaluation in the future development process. The evaluation is colour-coded, where white represents not evaluated, yellow meaning more evaluation is required, red represents requirements/desires no longer needing evaluations and green is evaluated requirements/desires, see Table 4.10 for most important requirements/desires and Appendix E for remaining part.

Table 4.10: Fulfilment table of the most important requirements/desires

No.	R/D F/NF	Requirement	Evaluation	Colour
1.3	R. F	Foil should break before pod	Simulation and Prototype	White
1.5	D. F	Angle of Attack of foils should be actively adjustable during operation	Engineering assessment/Prototype	Green
1.6	R. F	Must not generate cavitation	Calculation/Simulation/Prototype	Yellow
1.8	R. F	Must generate lift	Calculations and simulation	Green
1.9	R. F	Must generate inverted lift	Calculations and simulation	Yellow
1.10	R. F	Must have a lift/drag ratio at design speed	Calculations and simulation	Green
1.11	D. F	Should have a lift/drag ratio at design speed	Calculations and simulation	Green
1.16	D. F	Should increase the boats energy efficiency (compared to same solution without foils)	Calculations/Simulation	Green
1.17	D. F	Should handle rolling motions of hull (in 2-4 pod installations)	Engineering assessment/Prototype	Yellow
1.18	R. NF	The product must be designed for an ideal speed of	Engineering assessment	Green
1.24	R. F	Must prevent entanglement of foreign objects	Engineering assessment/Prototype	Yellow
2.1	R. NF	Pod+foils must have a decreased weight in regard to the initial design of pod	Calculations	Yellow
2.3	R. F	Must withstand loads applied to it during operation	Calculations/Simulation	Yellow
2.5	R. NF	Must handle a storage temperature	Engineering assessment/Prototype	Yellow
2.7	R. NF	Must be able to handle salt water	Engineering assessment	Green
2.8	R. NF	Must be able to handle UV radiation	Engineering assessment	Green
2.9	R. NF	Must withstand corrosion	Engineering assessment/Prototype	Yellow
2.10	R. NF	Surface layer must be tough to withstand intensive cleaning and chemicals	Engineering assessment/Prototype	Yellow
5.1	R. NF	Must not use material which is included in the Volvo Top Critical Materials list	Engineering assessment	Green
14.1	R. NF	Must not cost more than a certain amount to produce the foils	Calculations	Yellow

Performance: Most of the concepts are quantitative and qualitative evaluated. Since the lift force could be calculated for the concepts, except *Comes Around*, the three concepts are evaluated and passed for this requirement. The concepts have been evaluated regarding numerous performance requirements/desires such as the lift/drag ratio, AoA should be actively adjustable and that the concepts are designed for an ideal speed of $15kn$. However, there are still some requirements the concepts need further verification against, such as if they generate cavitation and how much inverted lift they can generate. The mechanical systems actively adjusting the amount of lift have not been included in the project, and have to be developed and validated in upcoming development. Requirements regarding safety, such as if the foils break before pod at impact, are not evaluated and need advanced simulations and prototype testing to evaluate.

Material and Environment: Regarding requirements concerning material, material which does not fulfil some of the requirements has been dismissed in the previous stage.

Theoretically, the material has been extensively evaluated. However, further engineering assessment and prototypes are required to securely determine if they pass the requirements. There are no validation and evaluation done regarding the resistance of galvanic corrosion regarding the concepts corresponding design, and combination of metals with different potentials such as stainless steel and aluminium. Regarding environmental aspects, neither of the thermoplastic or thermosets composites can be recycled, but for the metals its is possible. The anti-fouling systems or environmental footprint are not evaluated nor investigated due to time limitations.

Documentation, Standards & Patent: The concepts are evaluated against some existing standards and guidelines, but future regulations might impact further development, therefore more evaluation is of interest. The same applies for patent infringement, the concepts have not been evaluated regarding this, see Appendix E.

Installations, Size & Cost: A rough cost estimation of the concepts has been conducted, therefore partly evaluated. However, a more refined evaluation is required with information from the company to assure a more precise number of the actual cost. The concept is developed with a size requirement, however, if the concept needs to generate more lift the width limitation of $2m$ can be exceeded for the *Single* and *Telescopic* concept. This will further evaluation determine. Regarding installation, it is linked to the interface between the pod and foils, which needs further development and therefore evaluation, see Appendix E.

4.7.2 Validation of hull efficiency

As the concepts have been developed with $15kn$ as a primary speed, the behaviour of the concepts implemented on different hulls at other speeds is uncertain. To validate the beneficial aspects of utilising the developed concepts on a hull throughout a range of speeds, and the effect of including both the drag and lift generated by the foil, the concept *Single* was included in the Savitsky method, see Section 2.1, and Section 4.1.2 for implementation of hydrofoils. The hydrofoil implemented into the Savitsky method has the parameters corresponding to the concept *Single*, enabling both lift and drag forces generated by the foil to be included, see Table 4.11 for foil parameters.

Table 4.11: Foil properties for validation of beneficial aspects

Object	Properties
Profile section	NACA3320
Planform	Tapered wing
Span Width	1.4 [m]
Chord Length	0.3 [m]
Taper Ratio	45%

As the generated lift depends on the viscous speed and AoA of the foil, the AoA of the foil had to be determined for each speed to maximise efficiency for all hulls. To do so, three different approaches were used, labelled **Alternatives**, see following below:

4. Development of hydrofoil concepts

Alternative 1: Constant AoA of the foil, independently of AoA of the hull. The AoA of foil was set to 7.5° , as this generates $7500N$ of lift at $15kn$.

Alternative 2: The AoA of the foil changes in regard to the speed. The foil maintains the same margin to cavitation as the margin to cavitation of 38% when generating $7500N$ at $15kn$. Implying the AoA of foil will decrease when speed is increased.

Alternative 3: The AoA of the foil is optimised to decrease the required thrust of the hull at every speed. Tries all alternative AoA below the point of cavitation, exploring what AoA is decreasing the required thrust the most, implying the hull specificity of this alternative. Assures at least 10% margin to cavitation is maintained.

The alternatives were calculated for two different hulls, the *Ideal* and *Large Steep* boat to conclude what alternative is the most beneficial, see Table 4.2 for hull specifications. The conclusion of the data from the different calculations regarding the behaviour of the foil is to be seen in Figure 4.33 and Appendix U.

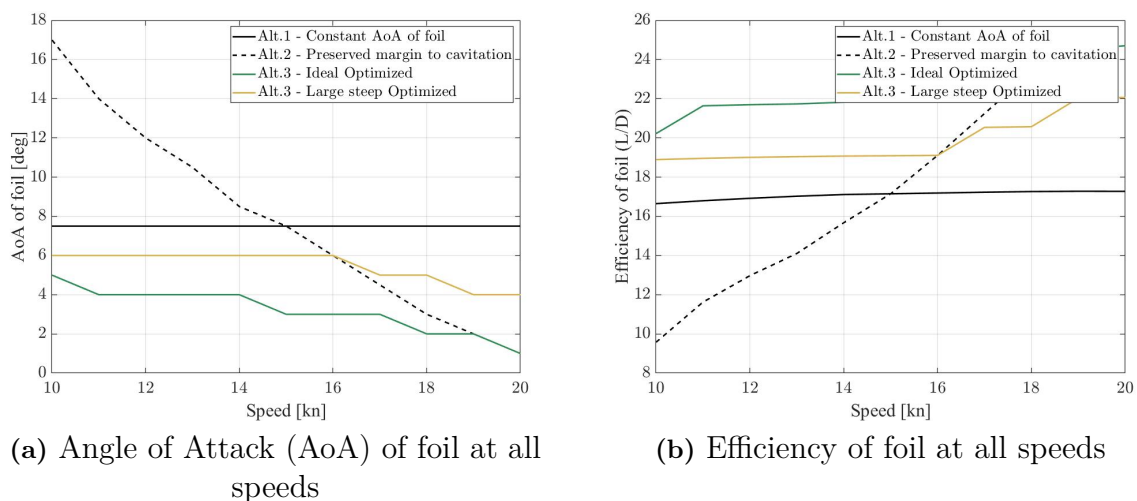

Figure 4.33: Investigating the foil with different running conditions and Angle of Attack

As seen in Figure 4.33a the AoA of the foil for the optimised alternative is decreased compared to the constant AoA alternative, implying that the lift is less than the full capacity of $7500N$ at $15kn$, see Appendix U. Further, the data in Figure 4.33b indicates that the foil is operated in a more efficient state with the optimised alternative compared to alternative 1 and 2. The alternative 3 is by that the option entailing the most decrease of thrust for each hull, implying that the AoA of the foil has to be individually adapted for each type of hull, see Appendix U.

To validate the beneficial aspects for different hulls, the Savitsky method was calculated for each hull with no foil implemented, and for foils implemented with alternative 3. The implemented foil is the concept *Single*, and for specifications of the hulls see Table 4.2.

The calculations was conducted, concluded and visualise, see Figure 4.34 and Appendix V.

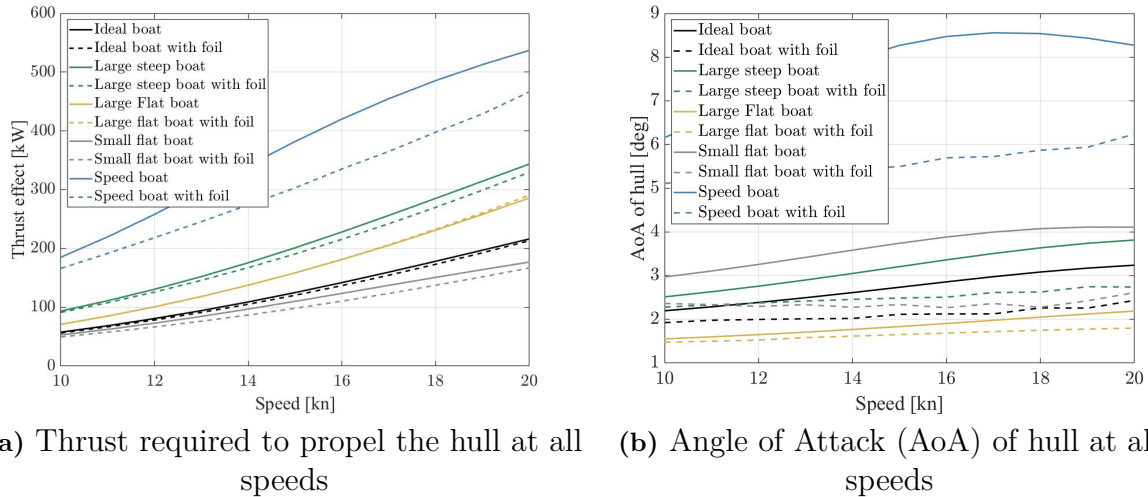

Figure 4.34: The effect of utilising the developed foil on different hulls

As seen in Figure 4.34a most of the hulls gain efficiency by the utilisation of foils, the only exception is the large flat boat which does not gain any significant increase nor decrease. This is expected as in the first calculations it was clear that the effect on the large flat boat was little, see Section 4.1.2. Utilising the foil on the majority of the hulls increases the efficiency 3 – 12% at 15kn, maintaining the benefit throughout the speed range, see Appendix V. Further, the AoA of the hull is decreased for all hulls, implying that the AoA throughout the speed range was more constant and even, compared to the case without implementation of foils, see Figure 4.34b.

The result indicates that the implementation of foils on the pod, enables the possibility to actively optimise the running conditions, compensating for differences in weight distribution and counteracting the rolling motion due to the waves. Enabling a stability system without adding any extra drag, increasing the comfort, usability, and visibility, keeping both the roll and the AoA of the boat at stable and favourable levels.

4.8 Ethics & Sustainability

Ethics and sustainability aspects are discussed in this section to ensure the relevance of developing the product, assure its outcome does not harm people, to take into consideration the effects on infrastructure and the environment. Since the implementation of this project, and the development of hydrofoils, do not contribute to major ethical dilemmas the discussion regards the outcome and implementation of hydrofoils on future boats with electrical propulsion. Further, discussion regarding how the project affects and is affected by the Sustainable Development Goals together with the upcoming sustainability targets are conducted.

An argument for not implementing the project is that the development of propulsion systems for boats enables the possibility for people to travel at sea and far from shore. This implies severe ethical issues that have to be considered as people might be thrown off at sea, get hit by a propeller, or other critical events/accidents occur, leading to a fatal outcome, entailing severe ethical issues which must be considered. One can argue that humans always have wanted to travel to distances far away [102], and that this is not going to change any time soon. This implies that travel by sea will continue regardless if this project is carried out or not, as humans always will find alternative approaches. For this reason, it is better that the project is carried out by a company with resources and enough knowledge to create products that are as safe for humans as possible, rather than homemade or low-tested products being used. Implying more optimised and effective developed products and therefore decreasing the environmental impact.

Regarding accidents, the product must be developed to ensure that the worst-case scenario is not fatal. For instance, if one of the foils breaks or if the foils start to behave strangely, there should be a fail-safe system reassuring a safe status of the system to ensure safety for the user, fellow boat travellers and people near. The same applies when the boat is stationed on land, regarding crush hazards if the power is turned on and the foil starts to make unforeseen movements or the user injures on sharp edges. The critical failure modes have been brought forward, see Section 4.6.2, but more elaboration regarding safety is needed.

There are today 17 Sustainable Development Goals (SDG), and the project endeavour to comply with some of these. The SDG nr *14 Life Below Water* has for instance targets regarding the coastal ecosystem, to maintain the ocean and use it sustainably [103]. Since the concepts are not evaluated regarding their noise emissions, decibel and frequency, and how they affect the natural habitat in the ocean, this is an aspect to determine and consider in future development. If the foils are too large or sharp they may harm marine mammals at impact, and if a non-environmental friendly anti-fouling system is used it will harm marine life and/or the ecosystem.

Since the scope of the project excludes internal combustion engines, focusing on electric propulsion systems, the fossil fuel consumption is already zero. However, the boat still needs an energy source to operate, and regardless of whether the electricity is fossil-free or not it will still somehow deprive and exploit the earth's resources, implying the importance to decrease the required energy consumption during the operation of the boat. This complies with the SDG nr *13 Climate Action*, which considers the greenhouse gases and climate changes [104]. The result of the project indicates that the foils can reduce the energy used by 5%, decreasing the emissions if not green electricity is used. Although, one can query if using luxury leisure boats for enjoyment is ethical, as there is no contribution to society and humanity. The EC's Green Deal is striving for a climate-neutral continent and that the greenhouse gases net emissions should be zero by 2050, by reducing it at least 55% by 2030 [105], implying extensive changes for the transport sector.

In a study from WSP Sverige a target/milestone of EC can be read stating that small vessels should not use diesel engines in EU by 2050, implying driving the electrification

of transport forward together with the already increased number of electric boats [106]. Further, the Mission Starfish 2030 by the EC has a target which states that leisure boats should have 100% non-fossil propulsion by 2030 [106] which is in a near future. The need for charging stations will increase as well as the demands on the infrastructure to enable the ability to charge the electrical boats. The positive aspect is that it drives innovation forward and the technology can be used between sectors, striving for a better environment.

The applicability and environmental aspects regarding the proposed materials thermosets and thermoplastic composites for the concepts can be discussed. Today, composites can be mechanical, thermal, or chemically recycled by various methods, but there are still obstacles regarding the processes, such as lower quality and high cost [107]. However, the use of composite drives the technology for recycling methods forward, since these materials increases in popularity and enables high freedom in design, are lightweight and nowadays easier to produce [108]. In the last decade, the production of the material and the products designed with these materials have been extensively developed, decreasing the environmental footprint and the cost of production. Often sustainability is neglected when choosing between metals and composites for products, because of the high performance of composites. Thorough consideration is needed regarding if it is worth using composites when the design allows being manufactured in other materials with higher benefits regarding recyclability. However, a decrease in the weight of the product often correlates to increased efficiency, implying the environmental footprint during the life cycle of the product has to be considered when choosing between composites and other materials.

5

Concept Catalogue

This chapter addresses the four concepts that was the result of the project, concluding each concept on one page in the format of a sheet. Each sheet contains estimated specification, description of the concept, and rendered CAD-model to visualise the concept. The data and information of the hydrofoils is derived from the project, see Chapter 4. The pod is estimated for visualisation purpose, and is by that not derived from anything. The following pages 72-75 contains these sheets in the order of *Single*, *Comes Around*, *Odd dual*, and *Telescopic*.



Single

Span width ex. pod	1.4m
Chord length	0.3m
Weight of foil	5.7kg
Taper ratio	45%

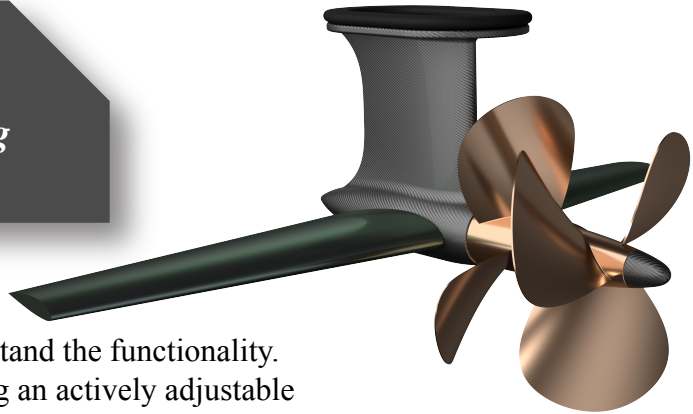

The concept Single is characterised by its simplicity of design and it is easy to understand the functionality. Enhancing the user experience by providing an actively adjustable lift force generated by one pair of foils. Targeted to minimise the complexity of the system, reducing the overall risk and necessity of maintenance. The concept inherits a set of sub-solutions, enabling case-specific combinations to be synthesised, enhancing the fulfilment of specific requirements.

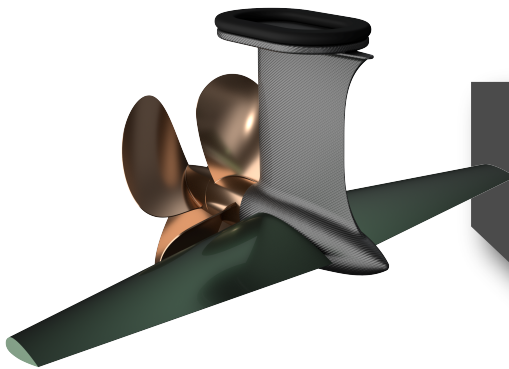

Material price	136:-
Manufac. cost	1150:-
Material	Reinforced POM-C
Manufac. method	Injection moulding

One synthesis of the concept was 3D-visualised and is the one rendered in the pictures. It is important that the stall characteristics of the foils assure that the root of the foil stalls before the tip of the foil, avoiding forcible rolling motions to suddenly appear. This can be ensured by wash-out and/or change of section profile along the lifting line. Further, the hydrodynamic interaction between the pair of foils has to be carefully considered at future design stages. The foils are preferably manufactured in the material reinforced POM-C with the manufacturing method injection moulding, decreasing the risk of corrosion and preserving the structural integrity. The fixated pair of wings can be included in the geometry and manufacturing process of the pod, implying the wing will be in the same material as the pod. If the case inquires other materials, aluminium with the manufacturing method of gravity die cast will be the option.



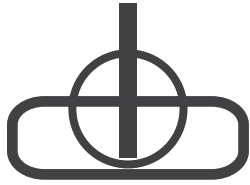

Comes Around

Span width	<i>0.95m</i>
Chord length	<i>0.3m</i>
Weight of foil	<i>8.1kg</i>
Taper ratio	<i>0%</i>

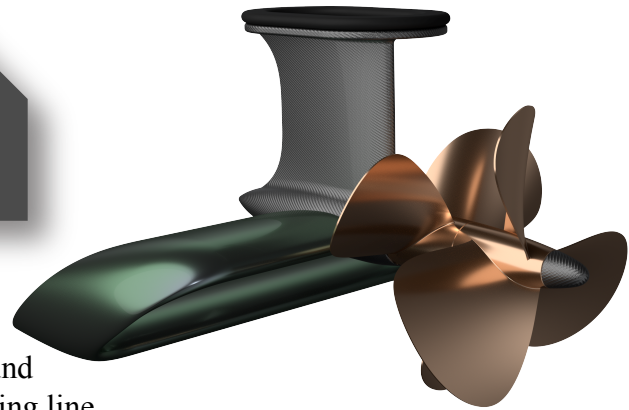

The concept *Comes Around* is characterised by innovation and its continuously wrapped foil around the pod, excluding physical distribution of the lifting line, minimising vortices and increasing the efficiency, implying this concept is the most lift/width intense of them all. Enhancing the user experience by actively adjusting the AoA of each side, enable the possibility to twist the foil and further extending its characteristics, including counter-acting the motor torque. The concept inherits a set of sub-solutions, enabling case specific combinations to be synthesised, enhancing the fulfilment of specific requirements.



Material price	<i>570:-</i>
Manufac. cost	<i>11350:-</i>
Material	<i>E-Glass fiber</i>
Manufac. method	<i>Autoclave</i>

One synthesis of the concept was 3D-visualised, and is the one rendered in the pictures. It is important to assure one part of the wing stalls before the other part by utilising wash-out, different initiation of AoA, and/or section profiles, avoiding drastic changes in lift. Dislocating the lower part of the foil from the rotational centre imply an increase of required moment generated by the mechanical system. Further, the hydrodynamic interaction between the upper and the lower part of the foil has to be carefully considered at future design stages. The complex geometry is preferable manufactured in E-Glass fiber with the manufacturing method Autoclave, decreasing the risk of corrosion and maintaining the structural integrity.





Odd Dual

Span width ex. pod	1.0&0.7m
Chord length	0.2&0.3m
Weight of foil	5.5kg
Taper ratio	45%

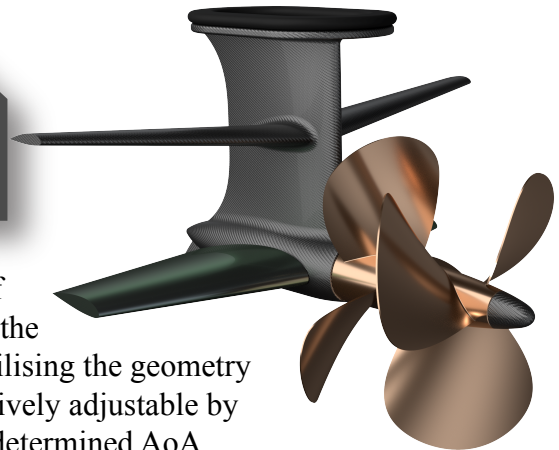

The concept Odd Dual is characterised by the trade-off between simplicity and lift/width intensity, decreasing the width by allocating the lift along to pair of foils and utilising the geometry of a Single foil. Enabling one pair of the foils to be actively adjustable by rotational motions, and the other pair to fixate at a predetermined AoA.

The modulation facilitates the possibility of different sales options, one with just the pair of fixed wings, and an option where the active pair is included, targeting a broader customer group. The concept inherits a set of sub-solutions, enabling case-specific combinations to be synthesised, enhancing the fulfilment of specific requirements.

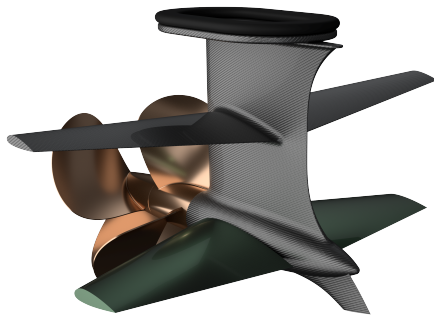

Material price	131:-
Manufac. cost	2280:-
Material	Reinforced POM-C
Manufac. method	Injection moulding

One synthesis of the concept was 3D-visualised and is the one rendered in the pictures. It is important that the stall characteristics of the foils assure that the root of the foil stalls before the tip of the foil, avoiding forcible rolling motions to suddenly appear. This can be ensured by wash-out and/or change of profile section along the lifting line. Further, the hydrodynamic interaction between the pair of foils has to be carefully considered at future design stages. The foils are preferably manufactured in the material POM-C with the manufacturing method injection moulding, decreasing the risk of corrosion and preserving the structural integrity. The fixated pair of wings can be included in the geometry and manufacturing process of the pod, implying the wing will be in the same material as the pod. If the case inquires other materials aluminium with the manufacturing method of gravity die casting will be the option.

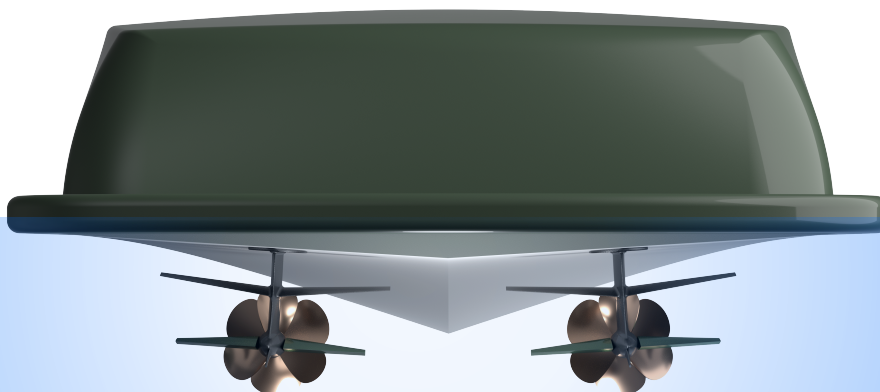



Telescopic

Span width ex. pod	1.4 - 0.7m
Chord length	0.3m
Weight of foil	5.1kg
Taper ratio	45%

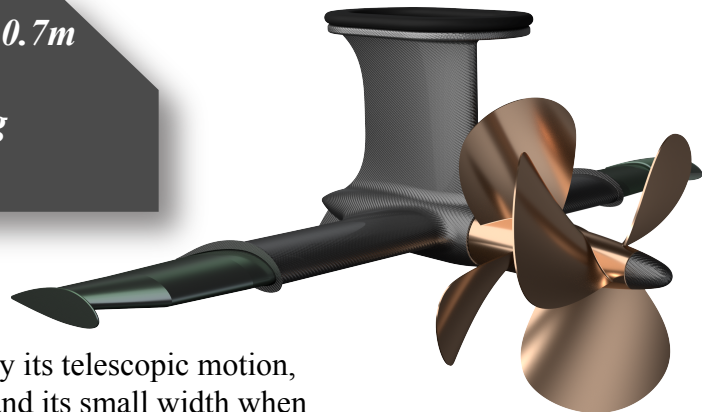

The concept Telescopic is characterised by its telescopic motion, extending the wingspan to increase lift, and its small width when stationary. Targeting to decrease the risk during harbour operations and onshore, by minimising the width and providing a compact product when not in operation. The concept inherits a set of sub-solutions, enabling case-specific combinations to be synthesised, enhancing the fulfilment of specific requirements.

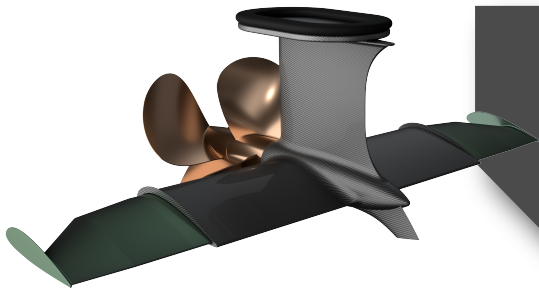

Material price	104:-
Manufac. cost	2020:-
Material	Reinforced POM-C & Aluminium
Manufac. method	Injection moulding & Gravity die cast

One synthesis of the concept was 3D-visualised and is the one rendered in the pictures. The wing fences are utilised to separate the boundary layers, preventing simultaneously stall of the foil. As the AoA is not adjustable the agility of the system entails how fast the lift can be changed, possible implying delays in the system. Further, the efficiency of the foil will vary in correlation to the changes in span width, implying the AoA should be predetermined to enable optimum span width at operation for the case-specific usage. The lift can never be decreased to zero as the fixed part of the foil always will be generating lift in relation to the predetermined AoA. The movable part of the foil is preferably manufactured in reinforced POM-C with the manufacturing method injection moulding, complying with corrosion and maintaining the structural integrity. The fixed part is preferable manufactured in the same material as the pod, in this case, presumed to be aluminium with the manufacturing method gravity die cast.

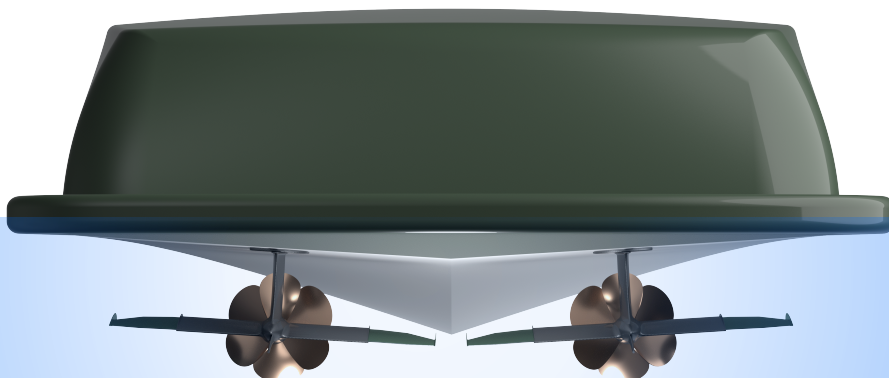

6

Conclusion

The four concepts in the concept catalogue are a success regarding the fulfilment of the main objectives. Attaching hydrofoils to the pod enables the resistance of most hulls to be reduced, and the foils are sufficient enough to decrease the total resistance of the system. Active adjustment of the generated lift during operation, enables uneven distribution of weight and rolling motions due to waves to be counteracted, maintaining a stable pitch and roll angle. The initial investigation of decreasing the hull resistance, indicated a higher improvement compared to the validation of the concepts, implying less increase in efficiency than initially anticipated, mainly because the drag of the foil was not included in the initial investigation. Implementation of hydrofoils on the pod enables an active adjustment system for boats to be implemented without decreasing the overall efficiency.

The concepts in the concept catalogue can with benefit be manufactured in reinforced POM-C, aluminium alloy, or E-glass fibre, enabling the complex design and operation in a submerged ocean environment. Reinforced POM-C in combination with the manufacturing method injection moulding is expected to be the least expensive alternative, handling corrosion and enabling complex designs, although entailing the lowest stiffness. Aluminium can be utilised to increase the recyclability of hydrofoils, entailing better mechanical properties regarding reinforced POM-C, and maintaining a similar material price. Although aluminium requires careful considerations regarding corrosion. E-Glass fibre composites enable the highest freedom of design, with sufficient stiffness and the highest strength in regard to aluminium and reinforced POM-C, entailing complex manufacturing methods and high manufacturing costs.

The knowledge regarding hydrofoil design is a complex and advanced field, each product is designed according to the specific usage case, utilising approximated calculations and extensive testing. Fluid dynamics allows the aeroplane theories to be applicable when conducting calculations on hydrofoils by altering the Re number, enabling the elaborated theories and approximations to be utilised. Implementing the forces generated by hydrofoils into the equilibrium equations in the Savitsky method, enabled a numerous amount of data to be generated and analysed, implying exploration of different cases to be conducted. This indicated that hulls designed and optimised for the specific operation speed is hard to affect and further optimise by implementing hydrofoils on the pod. There are many ideas and theories regarding how to optimise the hydrofoil to increase the efficiency, although this often magnifies the complexity of the design, implying more expensive materials and manufacturing methods. The greatest challenge is thus to design hydrofoils which complies with sufficient material and manufacturing method, enabling commercialisation and sustainable business.

7

Discussion

Following chapter contains a discussion regarding the project, the implemented method, source of errors in the project, and the results validity. Further a discussion about how the project can proceed regarding additional product development of the mechanical systems, evaluation, calculations, and simulations.

7.1 Method, Results & Source of error

At the beginning of the project, an investigation regarding differences in section profile was conducted to evaluate which could be used without stalling or creating cavitation at small AoA on the foil. Section profiles were mostly evaluated and since the 2D CFD software already had implemented data regarding the NACA foils, this was used out of simplicity reasons to be able to evaluate plentiful foil sections. However since the aim was to develop hydrofoils, section profiles optimised for use in water would have been an advantage to look upon, to assure even more realistic result, since the used profile section in the future will be developed and optimised for the occasion.

The quantitative assessment regarding roll was not investigated in this project due to time limitations and because of the uncertainty regarding the magnitude of the need to manage it. These are aspects which need further investigation. This project had benefited from a customer needs study to find the needs and corresponding requirements of the end-user along with the boat builder, to be able to evaluate the magnitude of the needs, and to assure a wide range of aspects were covered. The project has relied on the knowledge of the company, but tacit, latent and observable needs may be missed. During the project, the developed concepts in the first iteration of the project were evaluated and screened on a higher objective basis concerning the refined concepts in the second iteration of the project. This to decrease the design-space of the project. However, if all of the principle concepts were to be refined on a detailed level with sub-solutions before the first evaluation the outcome could have been different.

Regarding source of error, when conducting CFD simulations in 3D the standardised method is used to investigate if the mesh is refined enough to ensure adequate results. The same applies to CFD simulations in 2D, where instead the number of nodes is investigated to reassure they are sufficient enough. This was not done in this project, however, the number of nodes was considerably increased from the default value and a reasonableness assessment was conducted on all produced values. Regarding 3D aspects, the lowest C_p is only produced in the open software for a 2D section profile with a constant chord

length, whereas an analyse regarding cavitation has been conducted with these values. This means that local low pressure which can arise on the foil during operation is not taken into consideration.

Savitsky was one of the methods used to implement the calculations throughout the project. Although the method has limitations regarding the trim angle; $2^\circ \leq \tau \leq 15^\circ$, speed coefficient; $0.60 \leq C_v \leq 13.0$, and wetted length-beam ratio; $0 \leq \lambda \leq 4$. The data produced when the variables exceed these limits should be used with prudence, and further testing and simulations need to be conducted to assure its validity. In discussions with experts and investigating other sources [39] regarding the resistance prediction, it is clarified that the method replicates physical tests/model tests conducted, but with an under or overestimation of it. Implying that the absolute value of the generated resistance is not correct, but the difference in resistance with and without foil is the value of interest.

The lifting line theory is valid for an aspect ratio of a wing above 4, and the dimensions used for the foil generate an AR above 4 for the refined concepts. For some of the concepts screened away in the first iteration, the AR was below 4, resulting in uncertainty regarding the results and their accuracy. The skin friction drag is overestimated for the hydrofoils which are not squared since the coefficient is determined for the longest constant chord length in the 2D CFD software. Although the interference drag is not calculated for the concepts in the project, which will cause an underestimation in drag at the area where the foil and pod attach and where several hydrofoils are placed near each other. This is an aspect to consider regarding the total drag of the hydrofoils.

7.2 Future work and recommendations

As for future work of this project, there is a need for further evaluation regarding the attachments between the hydrofoils and the pod, 3D CFD analysis, build prototypes and eventual physical testing. To be able to conduct these steps further calculations regarding the strength of material need to be conducted along with modal analysis, a non-uniformly distributed load and to include the pitch moment. High cycle fatigue analysis, and possibly low cycle fatigue analysis, need to be conducted on the hydrofoils with selected material and derived dynamic loads. Regarding composites it is advanced, and the layup for the concepts created in thermoset composites requires further investigation and calculations to be determined. Further, the hydrofoil will not only be exposed to the optimal load of 7500N, situation will arise when exposed to higher loads, resulting in the need to derive these loads and conduct analysis, to estimate its service life.

The concepts have to be detailed design, emphasis on evaluating the required force to change the AoA of the foil to ensure enough structural strength, along with developing an internal structure which can be manufactured with the appropriate manufacturing process without highly increasing the weight of the product. Ensuring the design complies with a future developed mechanical system of the adjustment system, in association with an investigation regarding the serviceability and expected frequency of changing parts, complying with the needs that have to be concluded in future development and investigations. Further, investigating the environmental impact with Life Cycle Assessment has to

be conducted, along with profound cost estimations regarding manufacturing, assembly, and transportation, investigating existing supply chains and options and concluding the most viable material. Corrosion and ageing of reinforced POM-C have to be further evaluated, to ensure the functionality of the product throughout its service life. Delamination of thermoset composites is an occurrence that has to be investigated, ensuring the risk is decreased even if the product is damaged, either by ensuring the laminate can handle the damage or protecting it with other solutions.

The section profile of the foil has not been optimised regarding the indifference in viscous speeds, the flow behind the propeller and in the free stream, alternating the lifting line. The design would require solutions such as an alternating section profile or a twist of the foil to enhance its performance and adjust for unwanted hydrodynamic effects. In this project, the calculations have been carried out with a constant speed of the fluid for the entire foil, and further work would be required to evaluate these aspects. Further, an inverted lift force has not been calculated, which is necessary if the pitch is to be altered in both ways, although the section profile NACA3320 seems to be able to generate approximately half of the generated lift as inverted lift before cavitation, when evaluation its derived C_L .

The concepts in the concept catalogue is expected to provide future development projects, investigating the opportunity of including hydrofoils in the design of for example a pod, and sufficient knowledge to assess what design is most viable for the specific case of usage. Assessing the business model and the corporate identity, concluding the profitability and marketability, ensuring the further development is complying with these needs and requirements, is to be conducted in future projects. Considering these aspects enables the final design to be a successful product.

Bibliography

- [1] P. Franklin, “Sustainability: A development strategy for major boat builders,” 2021. [Online]. Available: <https://www.metstrade.com/news/sustainability/sustainable-goals-business-strategy-boat-builders/> (visited on 01/21/2022).
- [2] Volvo Group, “This is Volvo Penta,” 2022. [Online]. Available: <https://www.volvo-penta.com/about-us/> (visited on 01/21/2022).
- [3] —, “Volvo Penta IPS engines,” 2022. [Online]. Available: <https://www.volvo-penta.com/marine/products/volvo-penta-ips/> (visited on 04/29/2022).
- [4] News Hound, “Hull vane: Enhancing performance and efficiency through technology,” 2015. [Online]. Available: <https://www.iims.org.uk/hull-vane-enhancing-performance-and-efficiency-through-technology/> (visited on 04/29/2022).
- [5] D. Savitsky, “Hydrodynamic design of planing hulls,” 1964. [Online]. Available: <https://www.boatdesign.net/attachments/hydrodynamic-design-of-planing-hulls-savitsky-1964-pdf.89527/>.
- [6] S. Gudmundsson, *General Aviation Aircraft Design*, 1st ed. Oxford, UK: Butterworth-Heinemann, 2014. DOI: <https://doi.org/10.1016/B978-0-12-397308-5.00009-X>. (visited on 03/11/2022).
- [7] R. Eliasson, L. Larsson, and M. Orych, *Principles of Yacht Design: Keel and Rudder Design*, 4th ed. Bedford Square, London: Adlard Coles Nautical, 2014. [Online]. Available: <https://ebookcentral.proquest.com/lib/chalmers/detail.action?docID=1569357> (visited on 03/30/2022).
- [8] A. Sullivan, “Aerodynamic forces acting on an airfoil,” 2010. [Online]. Available: https://physics-archive.wooster.edu/JrIS/Files/Sullivan_Web_Article.pdf (visited on 06/09/2022).
- [9] UIUC Applied Aerodynamics Group, “UIUC Airfoil Coordinates Database,” 2022. [Online]. Available: https://m-selig.ae.illinois.edu/ads/coord_database.html#N (visited on 03/30/2022).
- [10] NASA, “NACA Airfoils,” 2017. [Online]. Available: <https://www.nasa.gov/image-feature/langley/100/naca-airfoils> (visited on 03/30/2022).
- [11] Airfoil Tools, “Naca 5 digit airfoil generator,” 2022. [Online]. Available: <http://airfoiltools.com/airfoil/naca5digit>.
- [12] J. Yang, L. Zhou, Z. Wang, and F. Zhi, “The effect of cavitation on the hydrofoil dynamic characteristics,” *Materials Science and Engineering*, no. 52, 2018. [Online]. Available: <https://iopscience.iop.org/article/10.1088/1757-899X/52/6/062018/pdf> (visited on 03/30/2022).
- [13] M. Morteza-zadeh, A. Katal, and K. Havadi, “Cavitation control on hydrofoils,” no. 181, 2014, Sharif University of Technology. [Online]. Available: https://aves.tia.com/HTFF2014_Proceedings/papers/181.pdf (visited on 05/11/2022).

- [14] Mecaflux, “Hydrodynamics, general,” 2021. [Online]. Available: <https://www.mecaflux.com/en/hydrodynamique.htm> (visited on 05/11/2022).
- [15] —, “The radical solution to the ship resistance to forward caused by waves:,” 2021. [Online]. Available: https://www.mecaflux.com/en/hydrofoil__foiler.htm (visited on 05/11/2022).
- [16] M. Jahanmiri, “Aircraft drag reduction: An overview,” 2011, Chalmers University of Technology. [Online]. Available: https://www.researchgate.net/publication/235339328_Aircraft_Drag_Reduction_An_Overview (visited on 05/11/2022).
- [17] J. Roskam and C.-T. E. Lan, *Airplane Aerodynamics and Performance*, 3rd ed. Lawrence, Kansas, USA: DARCorporation, 2003. [Online]. Available: https://books.google.se/books?id=bSq-cEf0EWsC&pg=PA204&lpg=PA204&dq=Interference+drag&source=bl&ots=iHNzDTNtwI&sig=ACfU3U3o_-0VjbfLwp7Y9EexiBgPTlo0Qw&hl=sv&sa=X&ved=2ahUKewj-graf6dn2AhUzSvEDHSYeDNc4ChDoAXoECAIQAw#v=onepage&q=Interference&f=false (visited on 05/03/2022).
- [18] P. K. Kundu, I. M. Cohen, and D. R. Dowling, *Fluid Mechanics (Fifth Edition)*, 5th ed. Oxford, UK: Academic Press, 2012. DOI: <https://doi.org/10.1016/B978-0-12-382100-3.10014-9>. (visited on 05/11/2022).
- [19] D. K. SobekII, A. C. Ward, and J. K. Liker, “Toyota’s principles of set-based concurrent engineering,” *Sloan Management Review*, vol. 40, no. 2, 1999. [Online]. Available: https://www.researchgate.net/publication/248139929_Toyota's_Principles_of_Set-Based_Concurrent_Engineering (visited on 04/29/2022).
- [20] A. Al-Ashaab et al., “The transformation of product development process into lean environment using set-based concurrent engineering: A case study from an aerospace industry,” *Sage Journals*, vol. 21, no. 3, 2013. DOI: <https://doi.org/10.1177/2F1063293X13495220>. (visited on 04/29/2022).
- [21] M. Flores, “Set-based concurrent engineering in cmi defence,” 2021. [Online]. Available: <https://lean-analytics.org/set-based-concurrent-engineering-in-cmi-defence/>.
- [22] K. Ulrich and S. Eppinger, *Product Design and Development*. New York, USA: McGraw Hill, 2020.
- [23] G. Gustafsson, “Lean product development,” Feb. 15, 2021.
- [24] E. Sanders, “Converging perspectives: Product development research for the 1990s,” *Design management Journal*, vol. 3, no. 4, 2010. [Online]. Available: https://www.researchgate.net/publication/229486501_Converging_Perspectives_Product_Development_Research_for_the_1990s (visited on 04/29/2022).
- [25] E. Sauerwein, F. Bailom, K. Matzler, and H. H. Hinterhuber, “The kano model: How to delight your customers,” *IX. International Working Seminar on Production Economics*, vol. 9, 1996. [Online]. Available: https://www.researchgate.net/publication/240462191_The_Kano_Model_How_to_Delight_Your_Customers (visited on 04/29/2022).
- [26] P. R. Childs, *Mechanical Design Engineering Handbook (second Edition)*, 2nd ed. Oxford, United Kingdom: Butterworth-Heinemann, 2019, pp. 81–93. DOI: <https://doi.org/10.1016/B978-0-08-102367-9.00003-2>. (visited on 03/30/2022).
- [27] M. Drela, *Xfoil-subsonic airfoil development system*, Massachusetts, USA, 2013. [Online]. Available: <https://web.mit.edu/drela/Public/web/xfoil/>.

- [28] MATLAB, *version 9.9.0.1592791 (R2020b), update 5*. Natick, Massachusetts: The MathWorks Inc., 2020. [Online]. Available: <https://se.mathworks.com/products/matlab.html>.
- [29] Y.-J. Kang, “The function tree analysis for new product development its applications,” 2010. [Online]. Available: <https://matriz.org/wp-content/uploads/2018/09/Dissertation-Young-Ju-Kang.pdf> (visited on 04/29/2022).
- [30] L. Almfelt, “System design - overview,” Jan. 18, 2021.
- [31] D. E. Woldemichael and F. M. Hashim, “Progressive concept evaluation method for automatically generated concept variants,” *MATEC Web of Conferences*, vol. 13, 2014. [Online]. Available: <https://doi.org/10.1051/mateconf/20141304007> (visited on 04/29/2022).
- [32] J. Ramík, *Pairwise Comparison Matrices in Decision-Making. In: Pairwise Comparisons Method. Lecture Notes in Economics and Mathematical Systems*. Springer, Cham, 2020, vol. 690. DOI: <https://doi.org/10.1007/978-3-030-39891-0>. (visited on 04/29/2022).
- [33] M. F. Ashby, *Materials Selection in Mechanical Design*, 4th ed. Kidlington, Oxford: Elsevier Ltd., 2011.
- [34] K. G. Swift and J. D. Booker, *Process Selection: From Design to Manufacture*, 2nd ed. Oxford, United Kingdom: Butterworth-Heinemann, 2003. [Online]. Available: <https://ebookcentral.proquest.com/lib/chalmers/reader.action?docID=288846&ppg=6> (visited on 03/30/2022).
- [35] ANSYS Inc, *Ansys granta edupack software*, Cambridge, UK, 2021. [Online]. Available: www.ansys.com/materials.
- [36] ANSYS®, *Academic research mechanical*, version 2021.R1. [Online]. Available: <https://www.ansys.com/products/structures/ansys-mechanical>.
- [37] Volvo Penta, “Easy Boating,” 2022. [Online]. Available: <https://www.volvopenta.com/marine/products/easy-boating-solutions/> (visited on 05/09/2022).
- [38] F. Ekman, C. N. Ribas, and F. Rydelius, *Model for predicting resistance and running attitude of high-speed craft equipped with interceptors*, BSc Thesis, Centre of Naval Architecture, Stockholm, Sweden, 2016. [Online]. Available: <https://kth.diva-portal.org/smash/get/diva2:1033545/FULLTEXT01.pdf>.
- [39] E. Lindbergh and F. Ahlstrand, “Methods to predict hull resistance in the process of designing electric boats,” MSc Thesis, Centre of Naval Architecture, KTH Royal Institute of Technology, Stockholm, Sweden, 2020. [Online]. Available: <https://www.diva-portal.org/smash/get/diva2:1465549/FULLTEXT01.pdf>.
- [40] P. R. Childs, *Mechanical Design Engineering Handbook (second Edition)*, 2nd ed. Oxford, United Kingdom: Butterworth-Heinemann, 2019, pp. 49–73. DOI: <https://doi.org/10.1016/B978-0-08-102367-9.00002-0>. (visited on 03/30/2022).
- [41] Volvo Group, *Chemical substances which shall be declared and substances that must not be present in Volvo Group products placed on the market - Volvo’s red list*, STD 100-0005. Gothenburg, Sweden: Volvo Group, 2022. [Online]. Available: <https://webstd.volvo.com/webstd/docs/100-0005> (visited on 03/18/2022).
- [42] —, *Chemical substances which must not be present in processes or chemical products within th Volvo Group - Volvo’s black list*, STD 100-0002. Gothenburg, Sweden: Volvo Group, 2022. [Online]. Available: <https://webstd.volvo.com/webstd/docs/100-0002> (visited on 03/18/2022).

- [43] DNV, *Rules For Classification of Ships*, SILENT Class Notation. Norway: Det Norske Veritas, 2010. [Online]. Available: https://havsmiljoinstitutet.se/digitalAssets/1784/1784725_dnv-ship-rules-pt.6-ch.24---silent-class-notation.pdf.
- [44] IMO, *GUIDELINES FOR THE REDUCTION OF UNDERWATER NOISE FROM COMMERCIAL SHIPPING TO ADDRESS ADVERSE IMPACTS ON MARINE LIFE*, MEPC.1/Circ.833. Albert Embankment, London: IMO Conventions, 2014. [Online]. Available: <https://cetsound.noaa.gov/Assets/cetsound/documents/MEPC.1-Circ%20883%20Noise%20Guidelines%20April%202014.pdf>.
- [45] IMO, “Ship noise,” 2019. [Online]. Available: <https://www.imo.org/en/MediaCentre/HotTopics/Pages/Noise.aspx> (visited on 03/30/2022).
- [46] F. Monsonnec, “The foil alphabet,” 2015. [Online]. Available: <https://www.foilingweek.com/wp-content/uploads/2015/04/The-foil-alphabet-Fred-Monsonnec-04-04-2015.pdf> (visited on 04/12/2022).
- [47] AlpineFoil, “Kitefoil origin,” 2022. [Online]. Available: <https://www.alpinefoil.com/en/kitefoil-windfoil-store/kitefoil/kitefoil-alpinefoil-origin.html> (visited on 04/12/2022).
- [48] Varuste, “Takuma E-foil Cruising,” 2022. [Online]. Available: <https://varuste.net/sv/p105511/takuma-e-foil-cruising> (visited on 04/12/2022).
- [49] R. Jourdan, “Horue’s Biplane Hydrofoil Concept,” 2022. [Online]. Available: <https://windfoilzone.com/horues-biplane-foil-concept/> (visited on 04/12/2022).
- [50] Iksurfmag, “Hydrofoil Kitesurfing Box Wing 2,” 2022. [Online]. Available: <https://www.iksurfmag.com/kitesurfing-news/2016/07/hydrofoil-kitesurfing-box-wing-2/> (visited on 04/12/2022).
- [51] Supernova Foil, “Supernova foil,” 2022. [Online]. Available: <https://www.supernovafoil.com/home> (visited on 04/12/2022).
- [52] America’s cup, “Two more boats: New design differences,” 2019. [Online]. Available: <https://www.americascup.com/en/news/535-TWO-MORE-BOATS-NEW-DESIGN-DIFFERENCES> (visited on 04/12/2022).
- [53] TechPowerUp, “The ‘flying yacht’ set to try and retain america’s cup for the us,” 2020. [Online]. Available: <https://www.techpowerup.com/forums/threads/the-flying-yacht-set-to-try-and-retain-americas-cup-for-the-us.230762/> (visited on 04/12/2022).
- [54] M. Sheahan, “The foiling phenomenon – how sailing boats got up on foils to go ever-faster,” 2015. [Online]. Available: <https://www.yachtingworld.com/special-reports/the-foiling-phenomenon-66269> (visited on 04/12/2022).
- [55] Vendée Globe, “Maître coq has been sailing with foils for the past 10 days,” 2016. [Online]. Available: <https://www.vendeeglobe.org/en/news/15181/maitre-coq-has-been-sailing-with-foils-for-the-past-10-days> (visited on 04/12/2022).
- [56] Candela, “Candela c-pod, a new frontier in propulsion technology,” 2022. [Online]. Available: <https://candela.com/technology/> (visited on 03/17/2022).
- [57] Mantaray, “Hydrofoil craft,” 2021. [Online]. Available: <https://www.mantaraycraft.se/> (visited on 04/12/2022).
- [58] Båtliv, “Norskt teknikföretag formar framtidens foilande båtar,” 2021. [Online]. Available: <https://www.batliv.se/2021/02/02/norskt-teknikforetag-formar-framtidens-foilande-batar/> (visited on 04/12/2022).

- [59] Hull Vane, “Dynamic hull vane,” 2022. [Online]. Available: <https://www.hullvane.com/products/> (visited on 04/12/2022).
- [60] Artemis Technologies, “Artemis efoiler,” 2022. [Online]. Available: <https://www.artemistechnologies.co.uk/efoiler/> (visited on 03/17/2022).
- [61] Pixar Cars Wiki, “Wingo,” 2022. [Online]. Available: <https://pixarcars.fandom.com/wiki/Wingo> (visited on 03/17/2022).
- [62] M. Robinson, “How the ford escort rs cosworth almost got a triple-decker wing,” 2020. [Online]. Available: <https://www.carthrottle.com/post/how-the-ford-escort-rs-cosworth-almost-got-a-triple-decker-wing/> (visited on 03/17/2022).
- [63] J. Gall, “The full vermonty: 2015 subaru wrx sti vs. 2004 subaru impreza wrx sti,” 2015. [Online]. Available: <https://www.caranddriver.com/features/a15106637/2015-subaru-wrx-sti-vs-2004-subaru-impreza-wrx-sti-feature/> (visited on 03/17/2022).
- [64] F. C. Ribeiro, A. A. D. paula, D. Scholz, and R. G. A. da Silva, “Wing geometric parameter studies of a box wing aircraft configuration for subsonic flight,” 2017. DOI: <http://dx.doi.org/10.13009/EUCASS2017-447>. (visited on 03/17/2022).
- [65] B. Coxworth, “Wacky-winged drones may have a flying ace up their sleeve,” 2021. [Online]. Available: <https://newatlas.com/drones/fly-r-rhomboidal-wing-drones/> (visited on 03/17/2022).
- [66] Scalemates, “Lee-richards annular monoplane,” 2019. [Online]. Available: <https://www.scalemates.com/kits/avis-bx-72036-lee-richards-annular-monoplane--1246026> (visited on 03/17/2022).
- [67] A. Clark, “Tail sitter aircraft: Say what?,” 2022. [Online]. Available: <https://disciplesofflight.com/tail-sitter-aircraft-say-what/> (visited on 03/17/2022).
- [68] NASA, “Winglets,” 2021. [Online]. Available: <https://www.grc.nasa.gov/www/k-12/airplane/winglets.html> (visited on 05/03/2022).
- [69] P. K. Chang, *Separation of flow*, 1st ed. London, United Kingdom: Pergamon, 1970. DOI: <https://doi.org/10.1016/C2013-0-05541-7>. (visited on 05/03/2022).
- [70] Elixir Aircraft, “Fences,” 2015. [Online]. Available: <https://elixir-aircraft.com/en/news/program-assessment> (visited on 05/03/2022).
- [71] Boldmethod, “How interference drag affects your plane’s performance,” 2022. [Online]. Available: <https://www.boldmethod.com/learn-to-fly/aerodynamics/how-interference-drag-affects-your-airplane-performance-and-decreases-performance-speed/> (visited on 05/03/2022).
- [72] NASA, “Flaps and stats,” 2021. [Online]. Available: <https://www.grc.nasa.gov/www/k-12/airplane/flap.html> (visited on 05/03/2022).
- [73] J. Sass, “Interceptors in theory and practice,” 2014. [Online]. Available: <http://sassdesign.net/Interceptors%20in%20theory%20and%20practice.pdf> (visited on 05/03/2022).
- [74] D. Andersen, “Understanding washout,” 2012. [Online]. Available: <https://www.modelaviation.com/washout> (visited on 05/03/2022).
- [75] D. Scholz, “Definition and discussion of the intrinsic efficiency of winglets,” 2017. [Online]. Available: https://www.fzt.haw-hamburg.de/pers/Scholz/Aero/AERO_PUB_WingletIntrinsicEfficiency_INCAS_Vol10No1_PrePrint.pdf (visited on 05/11/2022).

- [76] F. Rubino, A. Nisticò, F. Tucci, and P. Carlone, “Marine application of fiber reinforced composites: A review,” 2020. DOI: <https://doi.org/10.3390/jmse8010026>. (visited on 05/02/2022).
- [77] Unifiedalloys, “Stainless steel grades and families: Explained,” 2003. [Online]. Available: <https://www.unifiedalloys.com/blog/stainless-grades-families> (visited on 04/25/2022).
- [78] Assda, “Marine,” 2020. [Online]. Available: <https://www.assda.asn.au/technical-info/grade-selection/316-the-first-step-up/43-marine> (visited on 04/25/2022).
- [79] Nickel Institute, “Practical guide to using duplex stainless steels,” 2020. [Online]. Available: <https://nickelinstitute.org/media/8d8b973e3233189/apracticalguide tousingduplex.pdf> (visited on 04/25/2022).
- [80] Aperam, “Aisi 317l: Molybdenum-bearing austenitic stainless steel,” 2022. [Online]. Available: <http://www.brasil.aperam.com/wp-content/uploads/2015/11/AISI-317L-Molybdenum-bearing-Austenitic-Stainless-Steel.pdf> (visited on 04/25/2022).
- [81] K. R. Larsen, “Selecting stainless steels for seawater pumps,” 2020. [Online]. Available: <https://www.materialsperformance.com/articles/material-selection-design/2016/05/selecting-stainless-steels-for-seawater-pumps> (visited on 04/25/2022).
- [82] Volvo Penta, “Volvo penta d4-dpi,” 2022. [Online]. Available: <https://www.volvo-penta.com/marine/products/aquamatic-sterndrive-diesel/aquamatic-sterndrive-diesel-engine-range/d4-dpi/#features> (visited on 04/25/2022).
- [83] Marineparts, “Aluminium propellers for inboard and outboards,” 2022. [Online]. Available: <https://www.marineparts.se/propellrar/aluminiumpropellrar/> (visited on 04/25/2022).
- [84] Matmatch, “Cast vs. wrought aluminium: Standards, properties and applications,” 2022. [Online]. Available: <https://matmatch.com/learn/material/cast-wrought-aluminium> (visited on 04/25/2022).
- [85] AlcoTec, “Understanding the alloys of aluminum,” 2012. [Online]. Available: <http://www.alcotec.com/us/en/education/knowledge/techknowledge/understanding-the-alloys-of-aluminum.cfm> (visited on 04/25/2022).
- [86] Blackstone Advanced Technologies, “Metal fabrication resources by blackstone advanced technologies,” 2017. [Online]. Available: <https://blog.blackadvtech.com/what-is-marine-grade-aluminum> (visited on 04/25/2022).
- [87] Reliance Foundry, “Marine grade aluminum,” 2022. [Online]. Available: <https://www.reliance-foundry.com/blog/marine-grade-aluminum> (visited on 04/25/2022).
- [88] Leitelt Brothers, “A356 & 356 aluminum sand castings,” 2022. [Online]. Available: <https://www.lbfoundry.com/356-aluminum-sand-casting.html> (visited on 04/25/2022).
- [89] Curbell Plastics, “Marine rovs (remotely operated vehicles),” 2022. [Online]. Available: [https://www.curbellplastics.com/Research-Solutions/Industry-Solutions/Markets/Marine-ROVs-\(Remotely-Operated-Vehicles\)](https://www.curbellplastics.com/Research-Solutions/Industry-Solutions/Markets/Marine-ROVs-(Remotely-Operated-Vehicles)) (visited on 05/02/2022).

-
- [90] Nylacast, “Polymers for subsea,” 2022. [Online]. Available: https://www.globalunderwaterhub.com/documents/documents2018/nylacast_polymers%20for%20subsea%2022-01-2019.pdf (visited on 05/02/2022).
- [91] M. Spoerk, C. Holzer, and J. Gonzalez-Gutierrez, “Material extrusion-based additive manufacturing of polypropylene: A review on how to improve dimensional inaccuracy and warpage,” 2019. DOI: <https://doi.org/10.1002/app.48545>. (visited on 05/02/2022).
- [92] Essentra, “The difference between amorphous and semi-crystalline plastics,” 2022. [Online]. Available: <https://www.essentracomponents.com/en-gb/news/product-resources/the-difference-between-amorphous-and-semi-crystalline-plastics> (visited on 05/02/2022).
- [93] DragonPlate, “Carbon fiber 101: What do isotropic, quasi-isotropic, and anisotropic mean,” 2022. [Online]. Available: <https://dragonplate.com/carbon-fiber-101-what-do-isotropic-quasi-isotropic-and-anisotropic-mean> (visited on 05/02/2022).
- [94] Fibre Glast, “What are prepregs?,” 2020. [Online]. Available: https://www.fibre-glast.com/product/about-prepregs/Learning_Center (visited on 05/02/2022).
- [95] Bcomp, “Sustainability,” 2022. [Online]. Available: <https://www.bcomp.ch/solutions/marine/> (visited on 05/03/2022).
- [96] A. Moudood, A. Rahman, A. Öchsner, M. Islam, and G. Francucci, “Flax fiber and its composites: An overview of water and moisture absorption impact on their performance,” 2018. DOI: <https://doi.org/10.1177/0731684418818893>. (visited on 05/03/2022).
- [97] M. Skiba, “Wall thickness guidelines for injection molded parts?,” 2019. [Online]. Available: <https://www.engineeringresourcecenter.com/blog/wall-thickness-guidelines-for-injection-molded-parts> (visited on 05/03/2022).
- [98] S. K. Bhudolia, P. Perrotey, G. Gohel, S. C. Joshi, P. Gerard, and K. F. Leong, “Optimizing bladder resin transfer molding process to manufacture complex, thin-ply thermoplastic tubular composite structures: An experimental case study,” 2021. DOI: <https://doi.org/10.3390/polym13234093>. (visited on 05/03/2022).
- [99] Von Falk Wilke, “Automated Composite Manufacturing and its Long-term Possibilities,” 2020. [Online]. Available: <https://www.swms.de/caesa/automated-composite-manufacturing-and-its-long-term-possibilities/> (visited on 05/16/2022).
- [100] L. S. Lipol and J. Haq, “Risk analysis method: Fmea/fmeca in the organizations.,” 2011. [Online]. Available: <https://citeseerx.ist.psu.edu/viewdoc/download?doi=10.1.1.419.7912&rep=rep1&type=pdf> (visited on 05/08/2022).
- [101] Resource Engineering, “Generic severity rating scale,” 2022. [Online]. Available: <https://qualitytrainingportal.com/resources/fmea-resource-center/traditional-rpn-fmea/generic-severity-rating-scale> (visited on 05/08/2022).
- [102] M. Patenaude, “What drives human exploration of the unknown?,” 2015. [Online]. Available: <https://www.rochester.edu/newscenter/journeys-into-the-unknown-91212/> (visited on 05/06/2022).
- [103] United Nations, “Goal 14: Conserve and sustainably use the oceans, seas and marine resources,” 2022. [Online]. Available: <https://www.un.org/sustainabledevelopment/oceans/> (visited on 05/06/2022).

- [104] —, “Goal 13: Take urgent action to combat climate change and its impacts,” 2022. [Online]. Available: <https://www.un.org/sustainabledevelopment/climate-change/> (visited on 05/06/2022).
- [105] European Commission, “A european green deal: Striving to be the first climate-neutral continent,” 2022. [Online]. Available: https://ec.europa.eu/info/strategy/priorities-2019-2024/european-green-deal_en#thebenefitsoftheeuropeangreendeal (visited on 05/06/2022).
- [106] WSP Sverige AB, “Electrification of leisure boats and infrastructure: The international arena,” 2021. [Online]. Available: https://www.businessregiongoteborg.se/sites/brg/files/downloadable_files/external.-electrification-of-leisure-boats-and-infrastructure_-international-arena-210426_1.pdf (visited on 05/03/2022).
- [107] Y. Yang, R. Boom, B. Irion, D.-J. Heerden, P. Kuiper, and H. de Wit, “Recycling of composite materials,” *Chemical Engineering and Processing: Process Intensification*, vol. 51, 2012. DOI: <https://doi.org/10.1016/j.cep.2011.09.007>. (visited on 06/13/2022).
- [108] Fortify, “4 reasons why composites are replacing traditional materials,” 2022. [Online]. Available: <https://3dfortify.com/composites-replace-traditional-materials/> (visited on 06/13/2022).
- [109] J. Carlton, *Marine Propellers and Propulsion*, 4th ed. Oxford, UK: Butterworth-Heinemann, 2019, ch. 12 - Resistance and Propulsion, pp. 313–365. DOI: <https://doi.org/10.1016/B978-0-08-100366-4.00012-2>. (visited on 04/11/2022).

A

Appendix

A Savitsky: Matlab Flowsharts

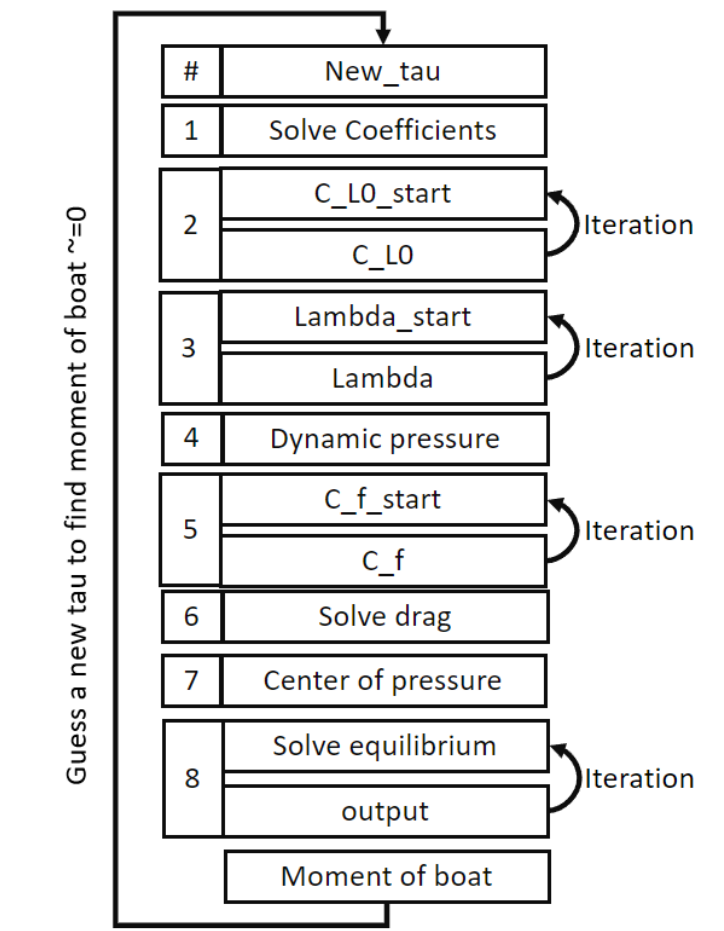

Figure A.1: Flowshart of the Savitsky Core Matlab script

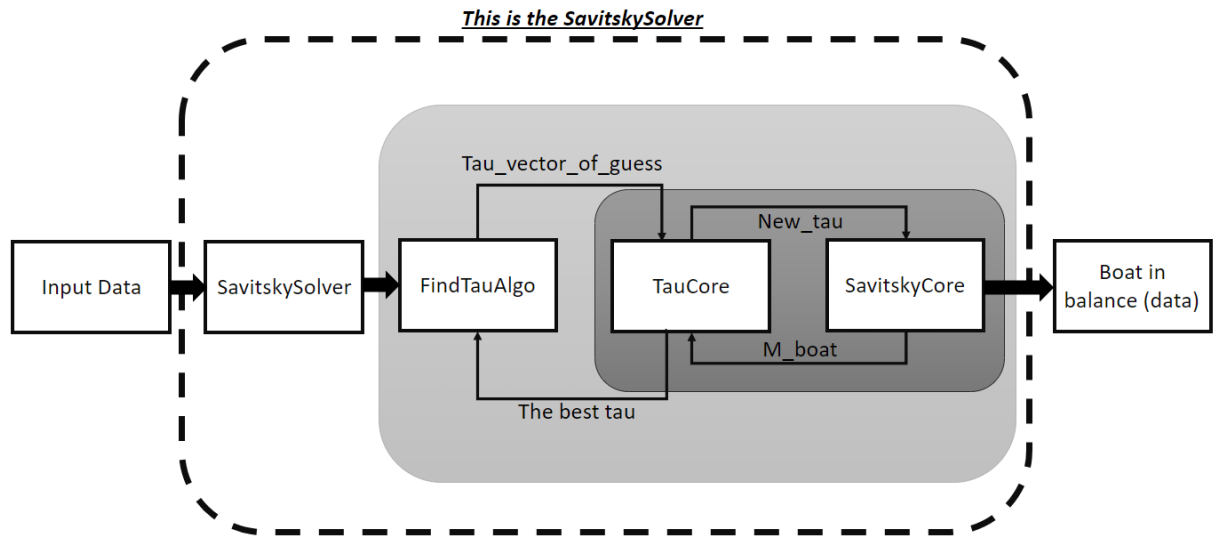

Figure A.2: Flow chart of the total Savitsky method Matlab script

B Savitsky hull resistance

Speed coefficient is calculated with equation A.1, valid for: $0.6 < C_v < 25$:

$$C_v = \frac{V}{\sqrt{gb}} \quad (\text{A.1})$$

Liftcoefficient for deadrise surface is calculated with equation A.2, valid for: $\beta > 0$:

$$C_{L\beta} = \frac{\Delta}{0.5\rho V^2 b^2} \quad (\text{A.2})$$

Liftcoefficient of the hull, defenition as a flat plate and calculated with equation A.3, valid for: $0 < C_{L0} < 0.1$:

$$C_{L0} = C_{L\beta} + 0.0065\beta \cdot C_{L0}^{0.6} \quad (\text{A.3})$$

Lambda, wetted length-beam ratio is calculated with equation A.4. Approximation valid for: $0 < \lambda < 4$:

$$C_{L0} = \tau^{1.1} \left(0.0120\lambda^{1/2} + \frac{0.0055\lambda^{5/2}}{C_v^2} \right) \quad (\text{A.4})$$

Average Dynamic pressure is calculated with equation A.5:

$$p_d = \frac{\Delta}{\lambda b^2 \cos(\tau)} \quad (\text{A.5})$$

Average bottom velocity is calculated with equation A.6:

$$V_1 = V \left(1 - \frac{2p_d}{\rho V^2} \right) \quad (\text{A.6})$$

Reynoldsnumber is calculated with equation A.7:

$$Re = \frac{V_1 \lambda b}{\nu} \quad (A.7)$$

Turbulent friction coefficient according to Schoenherr equations, others might use ITTC, is calculated with equation A.8. Schoenderr tend to be higher than ITTC [109]:

$$\frac{0.245}{\sqrt{C_f}} = \log(R_n \cdot C_f) \quad (A.8)$$

The Mass density of water is calculated with equation A.9, y = Specific weight of water [lbf/ft^3],

$$\varphi = \frac{y}{g} \quad (A.9)$$

Viscous component of drag is calculated with equation A.10, $\Delta C_f = 0.0004$ is extra friction of the bottom of hull:

$$D_f = \frac{\varphi V_1^2 \lambda b^2 (C_f + \Delta C_f)}{2 \cos(\beta)} \quad (A.10)$$

Total drag of hull is calculated with equation A.11:

$$D = \Delta \tan(\tau) + \frac{\varphi V_1^2 \lambda b^2 (C_f + \Delta C_f)}{2 \cos(\beta) \cos(\tau)} \quad (A.11)$$

Center of pressure is calculated with equation A.12:

$$C_p = 0.75 - \frac{1}{\frac{5.21 C_v^2}{\lambda^2} + 2.39} \quad (A.12)$$

Distance between center of pressure and center of gravity is calculated with equation A.13. Defined parallel to keel:

$$c = LCG - C_p \lambda b \quad (A.13)$$

Distance between viscouse drag coefficient and center of gravity is calculated with equation A.14. Defined normal to D_f

$$a = VCG - (b/4) \cdot \tan(\beta) \quad (A.14)$$

C Hull-Resistance

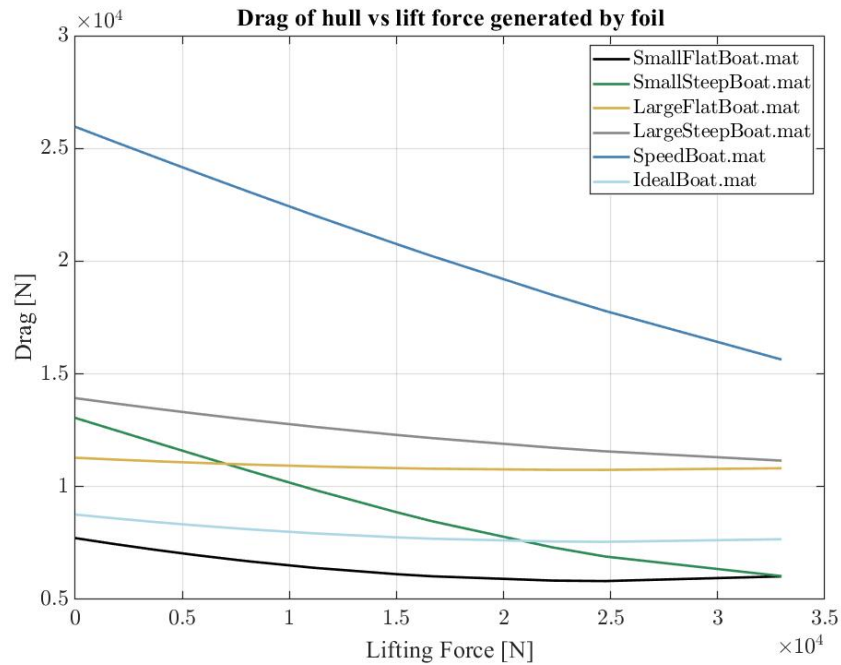

Figure A.3: Drag of hull vs Lift force generated by foil for the hull resistance investigation, for all hulls

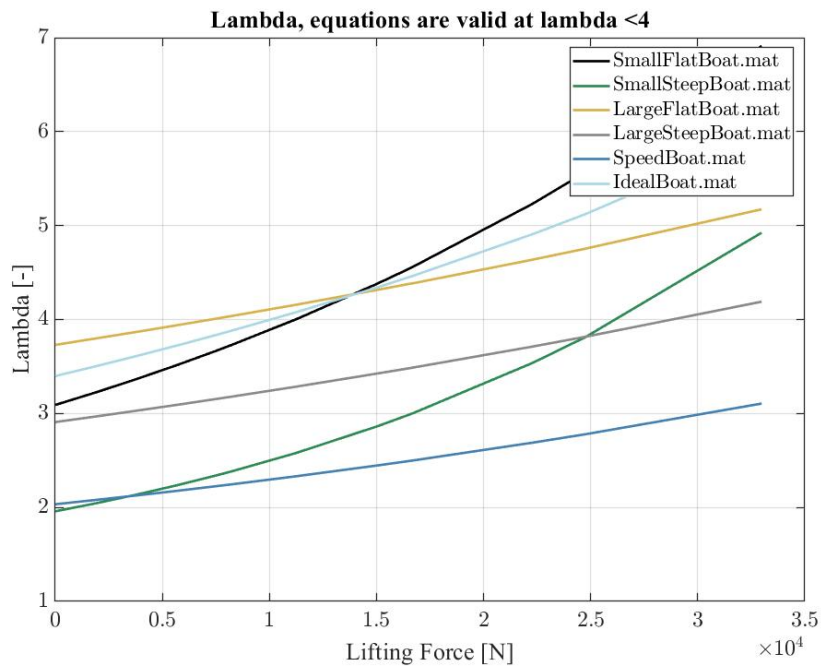

Figure A.4: Lambda value vs Lift force generated by foil for the hull resistance investigation, for all hulls

D Foil section - compare section profile

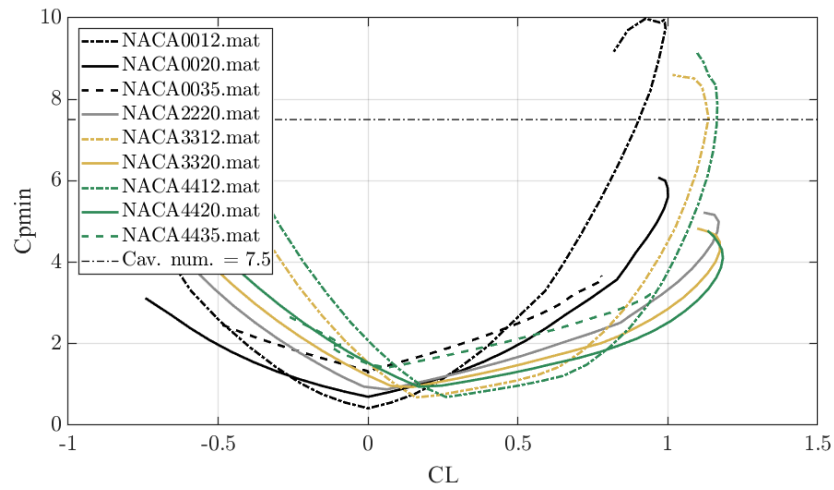

Figure A.5: Section profile comparison with chord length 0.2m and a speed of 10kn

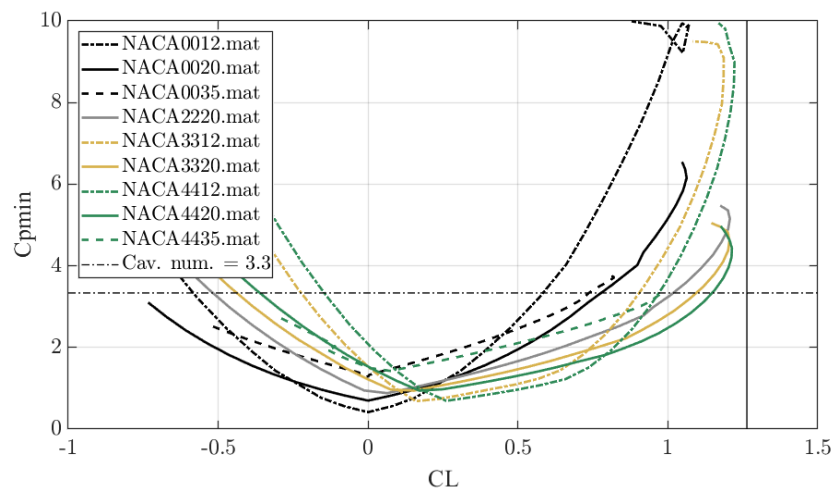

Figure A.6: Section profile comparison with chord length 0.2m and a speed of 15kn

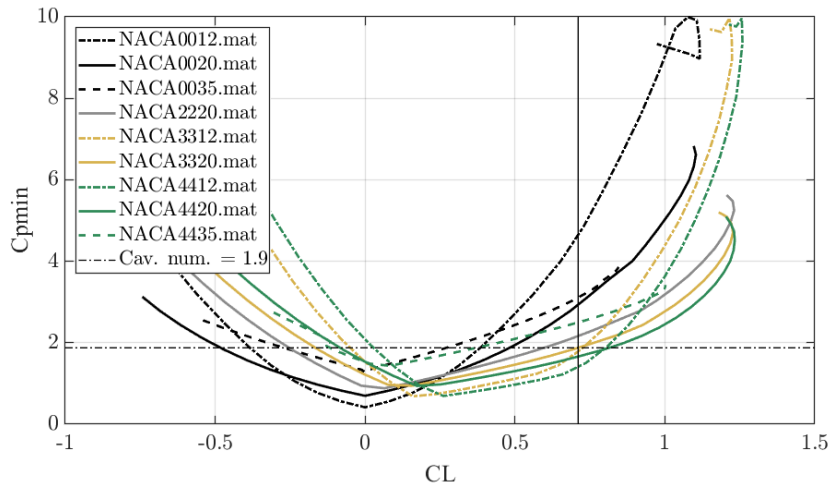

Figure A.7: Section profile comparison with chord length 0.2m and a speed of 20kn

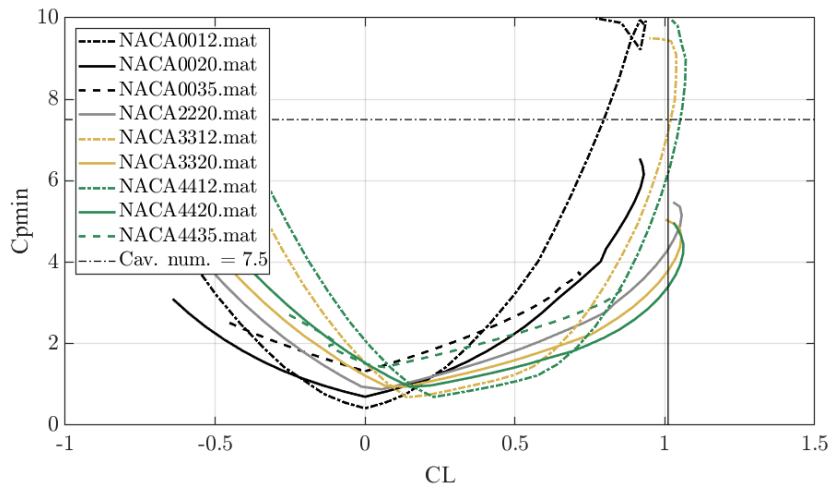

Figure A.8: Section profile comparison with chord length 0.3m and a speed of 10kn

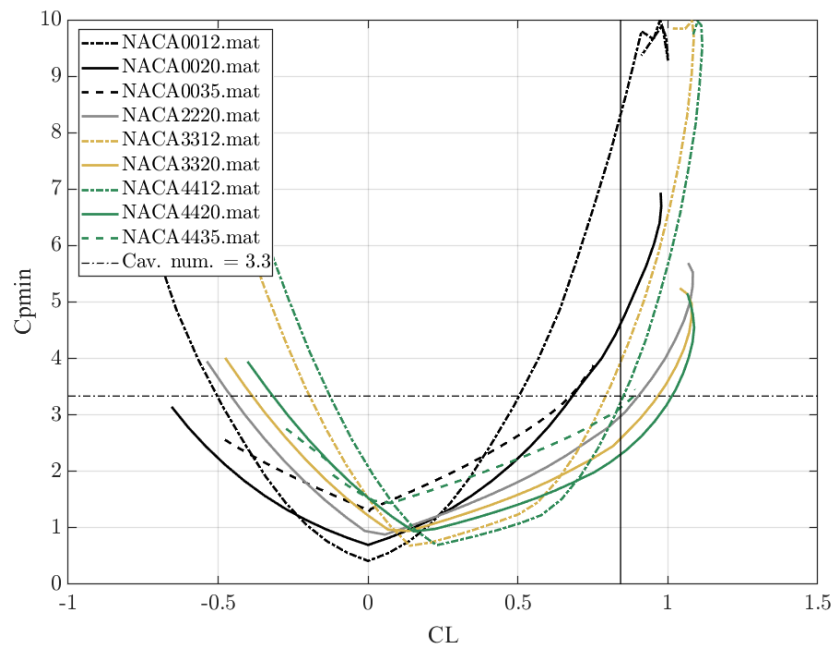

Figure A.9: Section profile comparison with chord length 0.3m and a speed of 15kn

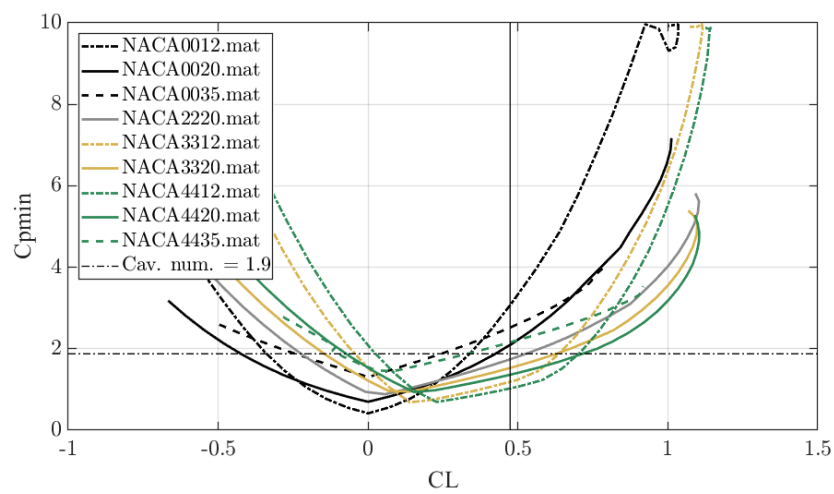

Figure A.10: Section profile comparison with chord length 0.3m and a speed of 20kn

E Requirement specification

SL No.	Req. (R) / Desire (D)	Requirement	Unit	Specification	Justification (stakeholder or standard)	Evaluation (Green=Evaluated, White=Not evaluated, Yellow=More evaluated req, Red=Not required)	Single
1.							
Performance							
1.1	NF	R	Binary	Pass/fail	Primary stakeholder	Simulation and Prototype	
1.2	F	R	Binary	Pass/fail	Primary stakeholder	Simulation and Prototype	
1.3	F	R	Binary	Pass/fail	Primary stakeholder	Simulation and Prototype	
1.4	NF	D	Binary	Pass/fail	Primary stakeholder	Engineering assessment	
1.5	F	D	Binary	Pass/fail	Primary user	Engineering assessment/Prototype	
1.6	F	R	Binary	Pass/fail	Primary user	Calculation/Simulation/Prototype	
1.7	F	D	Degrees	-15 <X<15	Primary stakeholder	Calculations and simulation	
1.8	F	R	N	>7500	Primary stakeholder	Calculations and simulation	
1.9	F	R	N	>2000	Primary stakeholder	Calculations and simulation	
1.10	F	R	ratio	8	Primary stakeholder	Calculations and simulation	
1.11	F	D	ratio	>15	Primary stakeholder	Calculations and simulation	
1.12	NF	R	Binary	Pass/fail	Primary stakeholder	Engineering assessment	
1.13	F	R	Nm	>=500	Primary stakeholder	Calculations/Simulation	
1.14	NF	R	mm	120	Primary stakeholder	Engineering assessment	
1.15	NF	R	Binary	Pass/fail	Primary stakeholder	Engineering assessment	
1.16	F	D	%	>10	Primary user/Customer	Calculations/Simulation	
1.17	F	D	Binary	Pass/fail	Primary user/Customer	Engineering assessment/Prototype	
1.18	NF	R	kn	15	Primary user	Engineering assessment	
1.19	NF	D	kn	20	Primary stakeholder	Engineering assessment	
1.20	NF	D	Binary	Pass/fail	Primary stakeholder	Engineering assessment	
1.21	NF	R	Binary	Pass/fail	Primary stakeholder	Engineering assessment	
1.22	NF	R	Binary	Pass/fail	Primary stakeholder	Engineering assessment	
1.23	NF	D	Nm	<100	Primary stakeholder	Calculations and simulation	
1.24	F	R	Binary	Pass/fail	P. user/S. user	Engineering assessment/Prototype	
1.25	NF	R	Binary	Pass/fail	R. agencies/Society	Calculations/Simulation	
Material							
2							
2.1	NF	R	%	> 15%	Primary user/stakeholder	Calculations	
2.2	NF	D	%	>50%	Primary user/stakeholder	Calculations	
2.3	F	R	Binary	Pass/fail	Primary Stakeholder	Calculations/Simulation	
2.4	NF	R	Degrees	-2<X<5	P. stakeholder/S. user	Engineering assessment	
2.5	NF	R	Degrees	-35<X<80	P. stakeholder/S. user	Engineering assessment/Prototype	
2.6	NF	D	Binary	Pass/fail	P. stakeholder/S. user	Engineering assessment	
2.7	NF	R	Binary	Pass/fail	Primary stakeholder	Engineering assessment	
2.8	NF	R	Binary	Pass/fail	Primary stakeholder	Engineering assessment	
2.9	NF	R	Binary	Pass/fail	P. stakeholder/S. user	Engineering assessment/Prototype	
2.10	NF	R	Binary & pH	Pass/fail & 0<X<13	P. user/S. user	Engineering assessment/Prototype	
2.11	NF	R	Binary	Pass/fail	P. stakeholder/S. user	Engineering assessment/Prototype	
2.12	NF	R	Binary	Pass/fail	Primary stakeholder	Engineering assessment	

Figure A.11: First part of the Requirement specification

3		Product life/service							
3.1	NF	R	Must have service life	Year	20	P. stakeholder/Customer	Durability testing/fatigue testing		
3.2	NF	R	Must have service interval	Year	1	P. stakeholder/Customer	Durability testing/fatigue testing		
3.3	NF	D	Should have service interval	Year	5	P. stakeholder/Customer	Durability testing/fatigue testing		
4		Quantity							
4.1	NF	R	Must sell a quantity of produced products	Qty./year	500-2000	Primary stakeholder	Statistics		
4.2	NF	D	Should sell a quantity of produced products	Qty./year	2000-5000	Primary stakeholder	Statistics		
5		Documentation/Standards							
5.1	NF	R	Must not use material which is included in the Volvo Top Critical Materials list	Binary	Pass/fail (Material)	STD 100-0005	Engineering assessment		
5.2	NF	R	Must comply with the Volvo group standard STD 100-0005	Binary	Pass/fail (Chemical substances)	STD 100-0005	Engineering assessment		
5.3	NF	R	Must comply with the Volvo group standard STD 100-0002	Binary	Pass/fail (Chemical substances)	STD 100-0002	Engineering assessment		
5.4	NF	D	The design should comply with the guidelines for reduction of underwater noise	Binary	Pass/fail (guidelines underwater noise)	MERC.1/Crc33	Engineering assessment		
5.5	NF	D	Should comply with maximum allowable noise level SILENT-E	Binary	Pass/fail (transit, underwater noise)	DNV SILENT Class Notation	Engineering assessment		
6		Health and safety							
6.1	NF	R	Must consider production safety/emissions/hazards	Binary	Pass/fail	R. agencies/Society	Engineering assessment		
6.2	NF	R	Employees in chain must comply with EU - Labor laws or similar	Binary	Pass/fail	R. agencies/Society	Engineering assessment		
7		Environmental issues							
7.1	NF	R	Must not bear organoicns compounds which act as biocides in anti-fouling systems	Binary	Pass/fail	Annex 1. Convention	Engineering assessment		
7.2	NF	D	Should reduce environmental footprint through the product life cycle	C. footprint	CO2e, Transport, production, disposal	Primary stakeholder	Lifecycle Assessment		
8		Disposal/end of life/Recycling							
8.1	NF	D	Amount of material should be recycled	%	25	P. stakeholder/R. agencies/Society	Lifecycle Assessment		
9		Patents							
9.1	NF	R	Must not interfere with other patents	Binary	Pass/fail	Primary stakeholder	Patent landscaping		
9.2	NF	R	Must not interfere with other design patents	Binary	Pass/fail	Primary stakeholder	Patent landscaping		
9.3	NF	D	Should be patentable	Binary	Pass/fail	Primary stakeholder	Patent landscaping		
10		Size (volume)							
10.1	NF	R	Must not exceed a width of	m	2	P. stakeholder/Customer	Calculations		
10.2	NF	D	Should not exceed number of parts (except gearing and drive shafts)	PCs	5	P. stakeholder/S. user	Engineering assessment		
11		Installation							
11.1	NF	D	Should enable installation without lifting equipment	Binary	Pass/fail	Secondary user/Customer	E. assessment/Prototype		
11.2	NF	D	Should enable the possibility to change foil without de-assemble the entire pod	Binary	Pass/fail	Secondary user	Engineering assessment		
12		Servicing costs							
12.1	NF	R	Foils must not add any extra service cost	Binary	Pass/fail	Primary user	Calculations		
13		Running costs							
13.1	NF	D	Must not be more than a certain running cost for foil and pod	SEK	0	Primary user	Calculations		
14		Product cost							
14.1	NF	R	Must not cost more than a certain amount to produce the foils	SEK	5000	P. stakeholder/Customer	Calculations		
14.2	NF	D	Should not cost more than a certain amount to produce the foils	SEK	2000	P. stakeholder/Customer	Calculations		

Figure A.12: Second part of the Requirement specification

F Matrix of correlations between requirements and criterias

Sl. No.	Req. (R) / Desire (D)	Comment	Efficiency (L/D)	Spaciousness	Manufacturing complexity /specialization/cost	Required volume of material	Complexity of machinery	Maintenance required (company/service)	Technical feasibility (TRL)	Risk for debris entanglement	User satisfaction	Safety	Innovation	Weight of component	Complexity/increased capability of machinery	Risk assessment (FMECA)
1.1	NF	R														
1.2	F	R														
1.3	F	R														
1.4	NF	D	For all concepts													
1.5	F	D														
1.6	F	R														
1.7	F	D														
1.8	F	R														
1.9	F	R														
1.10	F	R														
1.11	F	D														
1.12	NF	R														
1.13	F	R														
1.14	NF	R	For all concepts													
1.15	NF	R	For all concepts													
1.16	F	D														
1.17	F	D														
1.18	NF	R														
1.19	NF	D														
1.20	NF	D														
1.21	NF	R														
1.22	NF	R														
1.23	NF	D														
1.24	F	R														
1.25	NF	R														
2		Material														
2.1	NF	R	For all concepts													
2.2	NF	D	For all concepts													
2.4	F	R														
2.5	NF	R	For all concepts													
2.6	NF	R	For all concepts													
2.7	NF	D														
2.8	NF	R														
2.9	NF	R														
2.10	NF	R														
2.11	NF	R														
2.12	NF	R														
2.13	NF	R														

Figure A.13: First part of the Matrix

G Subjective and objective values

Subjective and objective values	1	2	3	4	5
Efficiency (L/D) [-]	>=8	>=12	>=16	>=20	>=24
Spaciousness, Large in area-extent/spanwidth [sub/m]	1/1,2	2/1	3/0,8	4/0,6	5/0,4
Manufacturing complexity/specialization [sub]	high		medium		low
Required volume of material [sub]	high		medium		low
Technical feasibility (TRL) [level]	0	<=2	<=3	<=5	<=9
Risk for debris entanglement [sub]	high		medium		low
User satisfaction [sub]	low		medium		high
Safety [sub]	low		medium		high
Innovation [sub]	low		medium		high

Figure A.15: Subjective and objective values of the criterias

H Pairwise comparison matrix

Criteria	A	B	C	D	E	F	G	H	I	J	K	Sum	Weight	
Efficiency (L/D)	A	-	0,5	1	1	1	1	1	0	1	1	8,5	0,155	
Spaciousness	B	0,5	-	1	1	1	1	1	0,5	1	1	9	0,164	
Manufacturing complexity/cost	C	0	0	-	1	0,5	1	1	0	0,5	0,5	5,5	0,100	
Required volume of materail	D	0	0	0	-	0	0,5	1	0	0	0	1,5	0,027	
Complexity of machinery	E	0	0	0,5	1	-	1	1	0,5	0	0,5	4,5	0,082	
Maintenance required (company/service/user)	F	0	0	0	0,5	0	-	1	0,5	0	0,5	3,5	0,064	
Technical feasibility (TRL)	G	0	0	0	0	0	0	-	0	0	0	0	0,000	
Risk for debris entanglement	H	0	0	0	1	0,5	0,5	1	-	0	0,5	0,5	4	0,073
User satisfaction	I	1	0,5	1	1	1	1	1	1	-	0,5	0,5	8,5	0,155
Safety	J	0	0	0,5	1	0,5	0,5	1	0,5	0,5	-	0,5	5	0,091
Innovation	K	0	0	0,5	1	1	0	1	0,5	0,5	0,5	-	5	0,091
Totalt:												55,0	1	
Legend		0=Worse	0,5=Same	1=Better										

Figure A.16: Pairwise comparison matrix for calculating the factor of weights

I Material index M1

For a light and stiff beam, with the objective function for the mass, the material indices becomes as follows:

$$m = AL\rho \quad (\text{A.15})$$

$$A = \pi(a + b)t \quad (\text{A.16})$$

The second moment of area I for a hollow ellipse is as follows:

$$I = \frac{\pi}{4}a^3t\left(1 + \frac{3b}{a}\right) \quad (\text{A.17})$$

S is the bending stiffness and it needs to be equal or higher to S^* which is a constant or a stated beforehand. The variable $C_2 = 8$ for this case.

$$S = \frac{C_2EI}{L^3} \geq S^* \quad (\text{A.18})$$

$$m = AL\rho = \left(\frac{S^*L^3}{8}\right) \cdot \left(\frac{\pi(a + b)L}{\frac{\pi}{4}a^3\left(1 + \frac{3b}{a}\right)}\right) \cdot \left(\frac{\rho}{E}\right) \quad (\text{A.19})$$

$$M_1 = \left(\frac{E}{\rho}\right) \quad (\text{A.20})$$

J Material index M2

For a light and strong beam the searched material indices becomes as follows:

$$m = AL\rho \quad (\text{A.21})$$

$$A = \pi(a + b)t \quad (\text{A.22})$$

The section modulus Z for a hollow ellipse is as follows:

$$Z = \frac{\pi}{4}a^2t\left(1 + \frac{3b}{a}\right) \quad (\text{A.23})$$

The stresses need to be lower than the yield strength, which is a constant or stated beforehand. The variable $C = 2$ for this case.

$$\sigma = \frac{F_fL}{CZ} \leq \sigma_y \quad (\text{A.24})$$

$$m = AL\rho = \left(\frac{F_fL}{2}\right) \cdot \left(\frac{\pi(a + b)L}{\frac{\pi}{4}a^2\left(1 + \frac{3b}{a}\right)}\right) \cdot \left(\frac{\rho}{\sigma_y}\right) \quad (\text{A.25})$$

$$M_2 = \left(\frac{\sigma_y}{\rho}\right) \quad (\text{A.26})$$

K Charts Material

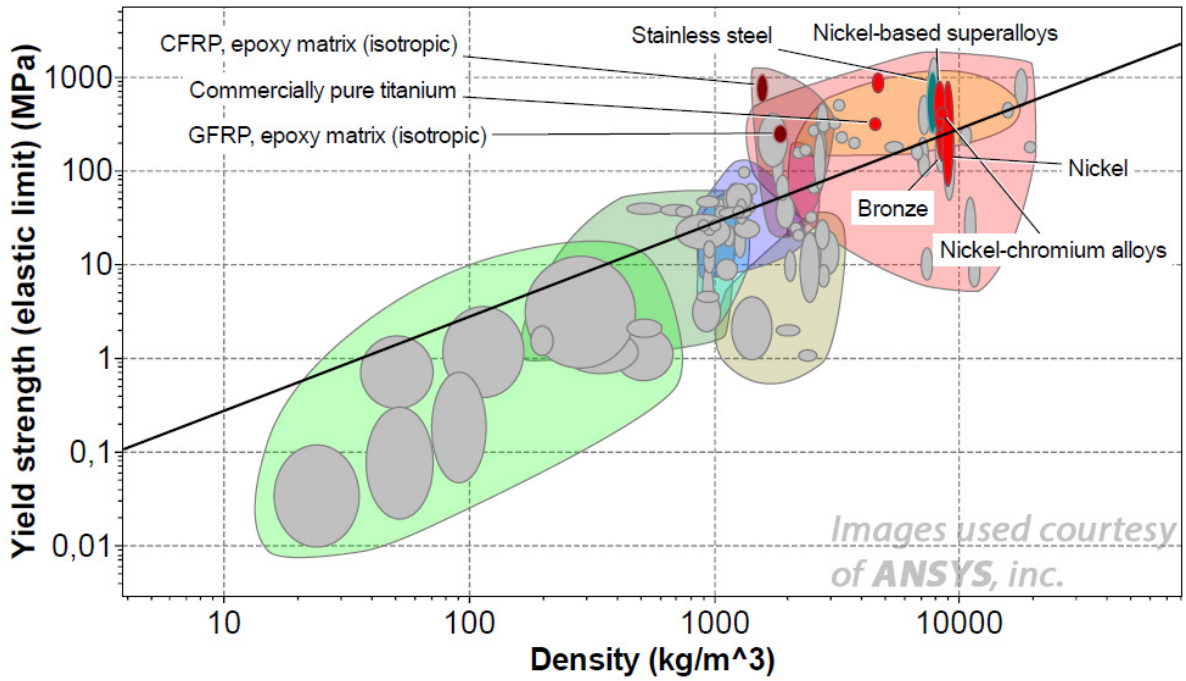

Figure A.17: Yield strength vs density

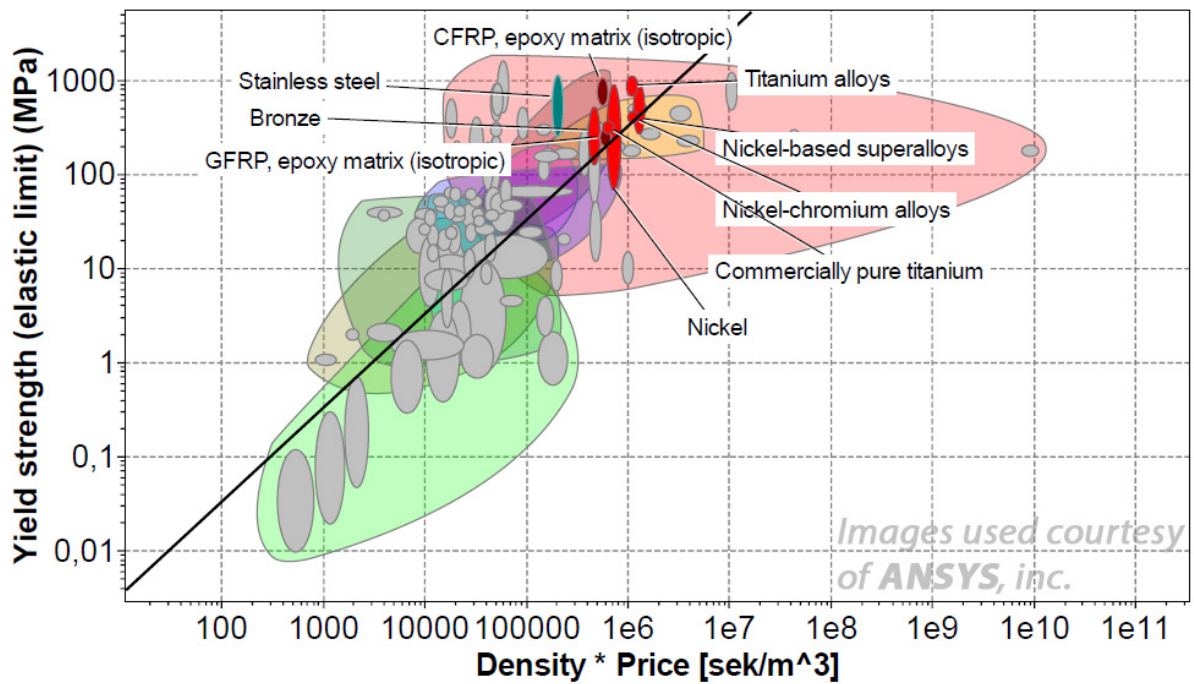

Figure A.18: Yield strength vs density times price

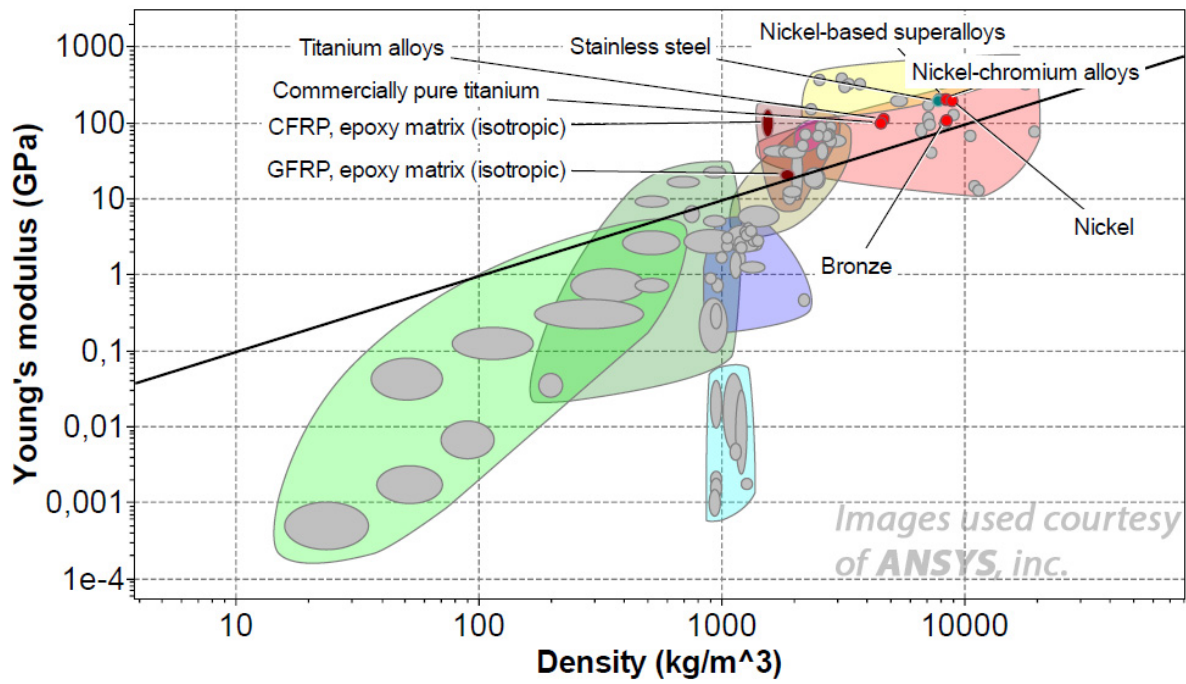

Figure A.19: Young's modulus vs density

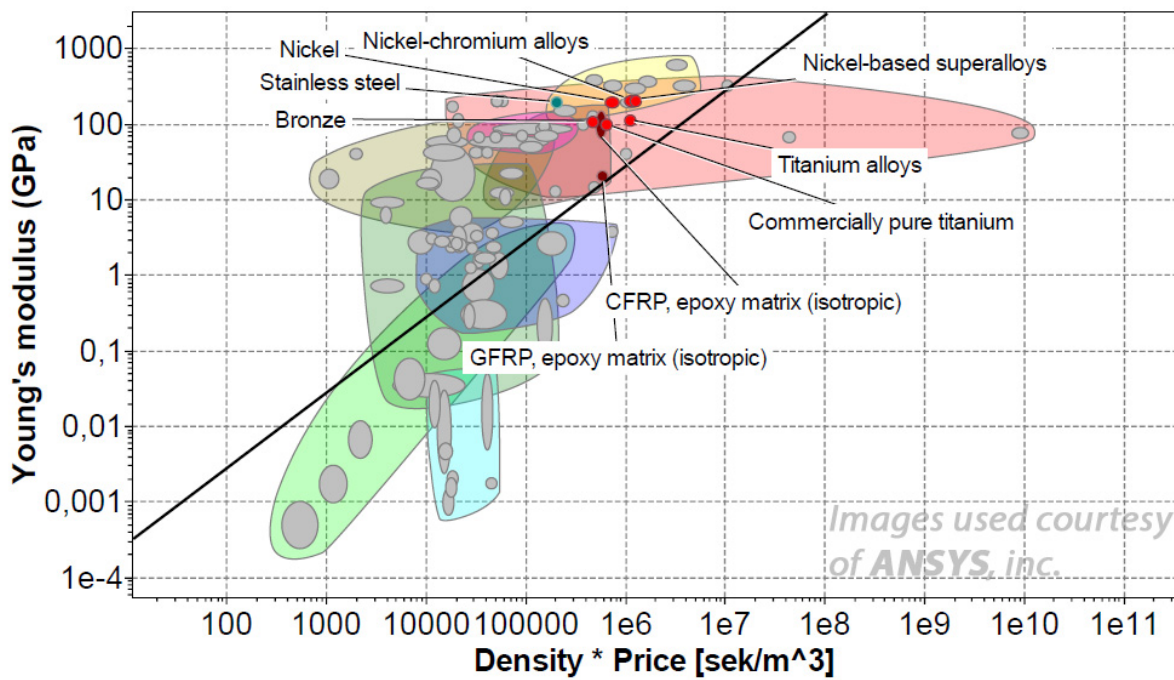

Figure A.20: Young's modulus vs density times price

L Morphological matrix Single concept

Provide a safe ride for the user		Enable Serviceability			Generate lift in a comfortable manner						
L	K	J	I	H	G	F	E	D	C	B	A
Prevent jack-knifing	Counteract propulsion motor torque (anti-torque)	Ensure integrity of hull at impact	Decrease risk of debris entanglement	Modularisation/ease of changing parts	Decrease and ease of cleaning	Handle corrosion and applied forces during operation	Control lift	Control stall	Prevent cavitation	Allocating lift area	Induce lift
Rotating center in front of center of pressure I1	Change shape of pod K1	Crack initiation (foil+pod break before interface) J	Sweep back LE I	Bolted/nourised from outside H1	Lift out of water G1	Composite (CFRP/GFRP) F1	Adjust Aoa by rotating foil E1	Adjust Aoa by rotating foil D1	Adjust Aoa by rotating foil C1	Straight single foil B1	Elliptic lifting line planforms A1
Fixed installation L2	Adjustable pod (Angled pod legs) K2	Make foil structure weaker than pod J2	Design without inner cones, (ex fillers/fairnes) I2	Bolted from inside of pod H2	Anti-fouling G2	Polymers F2	Extendable foils with linear activators E2	Multiple profile sections D2	Cavitation plate C2	Straight multiple foils B2	Hershey-bar (straight) A2
	NOTAR technology (water instead) ** K3		Air pressure (through holes) I3	Interference fit H3		Metal F3	Increase chord length with Slats E3	Wash-out (twist) D3		Continuous foil B3	
	Twist wing to create moment K4		Razor blades at the LE/stagnation point I4				Adjust span-width by adjusting the sweep of the wing E4	Wing fences D4			
	Fenestron/open tail rotor * K5						Adjust span-width by adjusting the dihedral of the wing E5	Slight swept tapered platform D5			
							Inflatable sections of wing E6	Vortex generators D6			
							Adjust Aoa with Flaps E7	Wash-in (twist) D7			
Not applicable for the specific concept group		Not suitable for the specific concept group			Originally not suitable for any concept group						
Not suitable for the specific concept group		Not suitable for the specific concept group			Constrained to the specific concept group						

Figure A.21: Morphological matrix single concept

M Morphological matrix Odd dual concept

Functions		Sub-solutions						
Sub-functions		1	2	3	4	5	6	7
A Induce lift	Elliptical planform	A1	Hershey-bar (straight)	A2				
B Allocating lift area	Straight single foil	B1	Multiple foils	B2				
C Prevent cavitation	Adjustable AoA rotating	C1	Cavitation plate	C2				
D Control stall	Adjust AoA by rotating foil	D1	Multiple profile sections	D2	Wash-out (twist)	D3	Wing fences	D4
E Control lift	Adjust AoA by rotating foil	E1	Extendable foils with inner activators	E2	Increase chord length with slats	E3	Adjust span-width by adjusting the sweep of the wing	E4
F Handle corrosion and applied forces during operation	Composite (CFRP/GFRP)	F1	Polymers	F2	Metal	F3	Adjust span-width by adjusting the dihedral of the wing	E5
G Decrease and ease of cleaning	Lift out of water	G1	Anti-fouling	G2				
H Modularisation/ ease of changing parts	Bolted/mounted from inside	H1	Bolted from inside of pod	H2	Interference fit	H3		
I Insensitive to debris entanglement	Sweep back	I1	Design without inner corners, (ex-fitters/aimms)	I2	Air pressure (through holes)	I3	Razor blades at the LE/stagnation point	I4
J Ensure integrity of hull at impact	Crack initiation (foil-pod break before interface)	J1	Make-foil structure weaker than pod	J2				
K Counteract propulsion motor torque (anti-torque)	Change shape of pod	K1	Adjustable pod (Angled pod legs)	K2	NOTAR technology (wakes instead)	K3	Twist wing to create moment	K4
L Prevent jack-knifing	Rotate center of pressure	L1	Fixed installation	L2			Fenestron/open tail rotor	K5
		Not applicable for the specific concept group						
		Not suitable for the specific concept group						
		Originally not suitable for any concept group						
		Constrained to the specific concept group						

Figure A.22: Morphological matrix Odd dual concept

N Morphological matrix Comes around concept

Functions		Sub-solutions						
Sub-functions		1	2	3	4	5	6	7
A Induce lift	Elliptical lifting line planforms A1	Hershey's airfoil A2						
B Allocating lift area	Straight single foil B1	Straight multiple foils B2	Curved multiple foils B3					
C Prevent cavitation	Adjustable AoA by rotating foil C1	Cavitation plate C2						
D Control stall	Adjust AoA by rotating foil D1	Multiple profile sections D2	Wash-out (twist) D3	Wing fences D4	Slight swept planform D5	Vortex generators D6	Wash-in (twist) D7	
E Control lift	Adjust AoA by rotating foil E1	Extendable foils with linear activators E2	Increase chord length with Slats E3	Adjust span-width by adjusting the sweep of the wing E4	Adjust span-width by adjusting the dihedral of the wing E5	Inflatable sections of wing E6	Adjust AoA with Flaps E7	
F Handle corrosion and applied forces during operation	Composite (CFRP, FRP) F1	Polymers F2	Metal F3					
G Decrease and ease of cleaning	Lift out of water G1	Anti-fouling G2						
H Modularisation/ ease of changing parts	Bolted/mounted from outside H1	Bolted from inside of pod H2	Interference fit H3					
I Insensitive to debris entanglement	Sweep back I1	Design without inner corners, (ex fillers/fairings) I2	Air pressure (through holes) I3	Razor blades at the LE/stagnation point I4				
J Ensure integrity of hull at impact	Crack initiation (foil-pod break before interface) J1	Make foil structure weaker than pod J2						
K Counteract propulsion motor torque (anti-torque)	Change shape of pod K1	Adjustable pod (Angled pod legs) K2	NOTAR technology (water instead) K3	Twist wing to create moment K4	Fenestron/open tail rotor K5			
L Prevent jack-knifing	Rotating center in front of center of pressure L1	Prevent installation L2						
	Not applicable for the specific concept group							
	Not suitable for the specific concept group							
	Originally not suitable for any concept group							
	Constrained to the specific concept group							

Figure A.23: Morphological matrix Comes around concept

O Morphological matrix Odd Berit concept

Functions		Sub-solutions						
Sub-functions		1	2	3	4	5	6	7
A Induce lift	Elliptical lift planforms	A1	Hershey-bar (straight)	A2				
B Allocating lift area	Straight single foil	B1	Staggered multiple foils	B2				
C Prevent cavitation	Adjustable AoA by rotating foil	C1	Cavitation plate	C2				
D Control stall	Adjust AoA by rotating foil	D1	Multiple profile sections	D2	Wash-out (twist)	D3	Wing fences	D4
E Control lift	Adjust AoA by rotating foil	E1	Extendable foils with linear activators	E2	Increase chord length with slats	E3	Adjust span-width by adjusting the sweep of the wing	E4
F Handle corrosion and applied forces during operation	Composite (CFRP/GFRP)	F1	Polymers	F2	Metal	F3	Adjust span-width by adjusting the dihedral of the wing	E5
G Decrease and ease of cleaning	Lift out of water	G1	Anti-fouling	G2				
H Modularisation/ease of changing parts	Bolted/mounted from outside	H1	Bolted from inside of pod	H2	Interference fit	H3		
I Insensitive to debris entanglement	Sweep back LE	I1	Design without inner corners, (ex fillets/airlines)	I2	Air pressure (through holes)	I3	Razor blades at the LE/stagnation point	I4
J Ensure integrity of hull at impact	Crack initiation (foil-pod/break interface)	J1	Make foil structure weaker than pod	J2				
K Counteract propulsion motor torque (anti-torque)	Change shape of pod	K1	Adjustable pod (Angled pod legs)	K2	NOTAR technology (water instead)	K3	Twist wing to create moment	K4
L Prevent jack-knifing	Rotate center in front of pod	L1	Fixed installation	L2			Fenestron/open tail rotor	K5
		Not applicable for the specific concept group						
		Not suitable for the specific concept group						
		Originally not suitable for any concept group						
		Constrained to the specific concept group						

Figure A.24: Morphological matrix Odd Berit concept

P Morphological matrix Telescopic concept

Functions		Sub-solutions						
Sub-functions		1	2	3	4	5	6	7
A Induce lift	Elliptic lifting line planforms		Hershey-bar (straight) A2					
B Allocating lift area	Straight angle foil	B1	Straight multiple foils B2	Continuous foil B3				
C Prevent cavitation	Adjustable AoA by rotating foil C1	Adjustable AoA by rotating foil C1	Cavitation plate C2	None				
D Control stall	Adjust AoA by rotating foil D1	Adjust AoA by rotating foil D1	Multiple profile sections D2	Wash-out (twist) D3	Wing fences D4	Slight swept tapered platform D5	Vortex generators D6	Wash-in (twist) D7
E Control lift	Adjust AoA by rotating foil E1	Extendable foils with linear actuators E2	Increase chord length with Slats E3	Adjust span-width by adjusting the sweep of the wing E4	Adjust span-width by adjusting the dihedral of the wing E5	Inflatable sections of wing E6	Adjust AoA with Flaps E7	
F Handle corrosion and applied forces during operation	Composite (CFRP/GFRP) F1	Polymers F2	Metal F3					
G Decrease and ease of cleaning	Lift out of water G1	Anti-fouling G2						
H Modularisation/ ease of changing parts	Bolted/ mounted from outside H1	Bolted from inside of pod H2	Interference fit H3					
I Insensitive to debris entanglement	Sweep back LE cores, (ex. riblets) I1	Design without inner ribs I2	Air pressure (through holes) I3	Razor blades at the LE/stagnation point I4				
J Ensure integrity of hull at impact	Crack initiation (foil-pod break before interface) J1	Make foil structure weaker than pod J2						
K Counteract propulsion motor torque (anti-torque)	Change shape of pod K1	Adjustable pod (Angled pod legs) K2	NOTAR technology (water instead) K3	Twist wing to create moment K4	Fenestron/open tail rotor K5			
L Prevent jack-knifing	Rotation center in front of center of pressure L1	Fixed installation L2						
		Not applicable for the specific concept group				Originally not suitable for any concept group		
		Not suitable for the specific concept group						

Figure A.25: Morphological matrix Telescopic concept

Q Manufacturing cost

Description	Unit	<i>Odd Dual Odd Berit</i>	<i>Comes Around</i>	<i>Telescopic</i>	<i>Single</i>
Area 1	[mm ²]	x	x	458311	x
Area 2	[mm ²]	x	1206689	368604	x
Material	[-]	Reinforced POM-C	E-Glass- fiber	Aluminum Reinforced POM-C	Reinforced POM-C
Wall thickness 1	[mm]	x	3	2	x
Wall thickness 2	[mm]	x	x	3	x
Volume 1	[mm ³]	0,001596	0,003620	0,000917	0,002961
Volume 2	[mm ³]	0,001265	x	0,001106	0,002961
Volume infill 20% extra 1	[mm ³]	0,003433	0,004344	0,001100	0,003554
Volume infill 20% extra 2	[mm ³]	x	x	0,001327	x
Material cost 1	[sek/kg]	24	70,5	18	24
Material cost 2	[sek/kg]	x	x	24	x
Density 1	[kg/m ³]	1595	1860	2710	1595
Density 2	[kg/m ³]	x	x	1595	x
Total material cost	[sek]	131,42	569,64	104,45	136,03
Total Volume	[dm ³]	3,43	4,34	2,43	3,55
Weight of concepts 1	[kg]	x	x	2,98	x
Weight of concepts 2	[kg]	5,48	8,08	2,12	5,67
Total Weight	[kg]	5,48	8,08	5,10	5,67
Manufacturing process	[-]	Injection Moulding	Autoclave	Gravity die Cast Injection Moulding	Injection Moulding
Cost manufacturing 1	[sek]	2280,00	11050	1000	1140,00
Cost manufacturing 2	[sek]	0,00	0,00	1020	0,00
Total cost of concept	[sek]	2280,00	11350,00	2020,00	1150,00

Figure A.26: Manufacturing cost for each concept

R FMECA

FMECA	Potential Failure Mode	Potential Failure Effects	Severity (1-10)	Potential Causes	Occurrence (1-10)	Current Controls	Detection (1-10)	RPN
Description	What could go wrong?	Impact on the customer?		What causes it?		How can it be prevented or detected?		
Single Concept	Pod breaks before foils	Malfunction of propulsion, personal injury	8	Foil in an impact with object	1	Structural weakness	1	8
	Foil does not break at impact	Malfunction of lift, unpleasant op., personal injury	10	Foil in an impact with object	3	Should not be prevented. Anyhow assure break at all speeds at proper impact, without harming user.	1	30
	Jack-knifing	Unexpected disruption in lift, unpleasant op. personal injury (roll, jack-knifing is worst)	10	Failure of AoA adjustment system	2	Assure Cp is behind Center of rotation at all AoA	1	20
	Cavitation	Noise during op. and unwanted erosion	4	To high speed/dynamic effects during op.	7	Physical testing	6	168
	Stalling	Loss of lift, unpleasant op.	6	To high/low AoA	6	Sufficient system control, geometrical design for comfortable stall characteristics	2	72
	Debris entanglement	Increase drag (less efficiency), loses all the propulsion	8	Insufficient geometrical design	4	Physical testing/sufficient geometrical design	4	128
	Corrosion	Break, decrease in efficiency, increased maintenance	5	Combination of materials, material choice	4	Material analyses/calculations, anode/ACP	6	120
	Failure of system controls	Unpleasant op., decrease, personal injury	10	Sensitive system, misreading from sensors/mailfunction, Improper failsafe-mode	2	Tests and calculations	2	40
	Underwater noise	Harming maritime life -> no op. in certain environments	7	Hydrodynamic effects	4	Test, simulation	9	252
	Unwanted hydrodynamic effects	Unpleasant op.	5	Poor designed foil	2	Tests	5	50
	Biofouling (E.g. barnacles)	Increase drag (less efficiency)	5	Pores leading to bacteria	8	Minimise pores, utilise anti-fouling systems	5	200
	Personal injuries when stationed on shore	Personal damage/injuries	10	Sharp edges, crush hazards, large movement of system	4	Geometrical design/design/system routines with minimized crush hazards	1	40
	Mechanical/operation noise	Unpleasant op., unpleased customer	5	Poor mechanical solution design, hydrodynamic effects	4	Design, tests, prototype	2	40
Total								1168

Figure A.27: FMECA on the concept Single

FMECA	Potential Failure Mode	Potential Failure Effects	Severity (1-10)	Potential Causes	Occurrence (1-10)	Current Controls	Detection (1-10)	RPN
Description	What could go wrong?	Impact on the customer?		What causes it?		How can it be prevented or detected?		
Odd Dual Concept	Pod breaks before foils	Malfunction of propulsion, personal injury	8	Foil in an impact with object	1	Structural weakness	1	8
	Foil does not break at impact	Malfunction of lift, unpleasant op., personal injury	10	Foil in an impact with object	3	Should not be prevented. Anyhow assure break at all speeds at proper impact, without harming user.	1	30
	Jack-knifing	Unexpected disruption in lift, unpleasant op. personal injury (roll, jack-knifing is worst)	10	Failure of AoA adjustment system	2	Assure Cp is behind Center of rotation at all AoA	1	20
	Cavitation	Noise during op. and unwanted erosion	4	To high speed/dynamic effects during op.	8	Physical testing	6	192
	Stalling	Loss of lift, unpleasant op.	6	To high/low AoA	6	Sufficient system control, geometrical design for comfortable stall characteristics	2	72
	Debris entanglement	Increase drag (less efficiency), loses all the propulsion	8	Insufficient geometrical design	6	Physical testing/sufficient geometrical design	4	192
	Corrosion	Break, decrease in efficiency, increased maintenance	5	Combination of materials, material choice	5	Material analyses/calculations, anode/ACP	6	150
	Failure of system controls	Unpleasant op., decrease, personal injury	10	Sensitive system, misreading from sensors/mailfunction, Improper failsafe-mode	5	Tests and calculations	2	100
	Underwater noise	Harming maritime life -> no op. in certain environments	7	Hydrodynamic effects	5	Test, simulation	9	315
	Unwanted hydrodynamic effects	Unpleasant op.	5	Poor designed foil	3	Tests	5	75
	Biofouling (E.g. barnacles)	Increase drag (less efficiency)	5	Pores leading to bacteria	8	Minimise pores, utilise anti-fouling systems	5	200
	Personal injuries when stationed on shore	Personal damage/injuries	10	Sharp edges, crush hazards, large movement of system	3	Geometrical design/design/system routines with minimized crush hazards	1	30
	Mechanical/operation noise	Unpleasant op., unpleased customer	5	Poor mechanical solution design, hydrodynamic effects	3	Design, tests, prototype	2	30
Total								1414

Figure A.28: FMECA on the concept Odd dual

A. Appendix

FMECA	Potential Failure Mode	Potential Failure Effects	Severity (1-10)	Potential Causes	Occurrence (1-10)	Current Controls	Detection (1-10)	RPN
Description	What could go wrong?	Impact on the customer?		What causes it?		How can it be prevented or detected?		
Comes Around Concept	Pod breaks before foils	Malfunction of propulsion, personal injury	8	Foil in an impact with object	3	Structural weakness	1	24
	Foil does not break at impact	Malfunction of lift, unpleasant op., personal injury	10	Foil in an impact with object	4	Assure break at all speeds at proper impact, without harming user.	1	40
	Jack-knifing	Unexpected disruption in lift, unpleasant op. personal injury (roll, jack-knifing is worst)	10	Failure of AoA adjustment system	1	Assure Cp is behind Center of rotation at all AoA	1	10
	Cavitation	Noise during op. and unwanted erosion	4	To high speed/dynamic effects during op.	7	Physical testing	6	168
	Stalling	Loss of lift, unpleasant op.	6	To high/low AoA	6	Sufficient system control, geometrical design for comfortable stall characteristics	2	72
	Debris entanglement	Increase drag (less efficiency), loses all the propulsion	8	Insufficient geometrical design	6	Physical testing/sufficient geometrical design	4	192
	Corrosion	Break, decrease in efficiency, increased maintenance	5	Combination of materials, material choice	3	Material analyses/calculations, anode/ACP	6	90
	Failure of system controls	Unpleasant op., decrease, personal injury	10	Sensitive system, misreading from sensors/mailfunction, Improper failsafe-mode	5	Tests and calculations	2	100
	Underwater noise	Harming maritime life -> no op. in certain environments	7	Hydrodynamic effects	6	Test, simulation	9	378
	Unwanted hydrodynamic effects	Unpleasant op.	5	Poor designed foil	5	Tests	5	125
	Biofouling (E.g. barnacles)	Increase drag (less efficiency)	5	Pores leading to bacteria	6	Minimise pores, utilise anti-fouling systems	5	150
	Personal injuries when stationed on shore	Personal damage/injuries	10	Sharp edges, crush hazards, large movement of system	1	Geometrical design/design/system routines with minimized crush hazards	1	10
	Mechanical/operation noise	Unpleasant op., unpleased customer	5	Poor mechanical solution design, hydrodynamic effects	6	Design, tests, prototype	2	60
Total								1419

Figure A.29: FMECA on the concept Comes around

FMECA	Potential Failure Mode	Potential Failure Effects	Severity (1-10)	Potential Causes	Occurrence (1-10)	Current Controls	Detection (1-10)	RPN
Description	What could go wrong?	Impact on the customer?		What causes it?		How can it be prevented or detected?		
Odd Berit Concept	Pod breaks before foils	Malfunction of propulsion, personal injury	8	Foil in an impact with object	1	Structural weakness	1	8
	Foil does not break at impact	Malfunction of lift, unpleasant op., personal injury	10	Foil in an impact with object	3	Should not be prevented. Anyhow assure break at all speeds at proper impact, without harming user.	1	30
	Jack-knifing	Unexpected disruption in lift, unpleasant op. personal injury (roll, jack-knifing is worst)	10	Failure of AoA adjustment system	2	Assure Cp is behind Center of rotation at all AoA	1	20
	Cavitation	Noise during op. and unwanted erosion	4	To high speed/dynamic effects during op.	9	Physical testing	6	216
	Stalling	Loss of lift, unpleasant op.	6	To high/low AoA	6	Sufficient system control, geometrical design for comfortable stall characteristics	2	72
	Debris entanglement	Increase drag (less efficiency), loses all the propulsion	8	Insufficient geometrical design	7	Physical testing/sufficient geometrical design	3	168
	Corrosion	Break, decrease in efficiency, increased maintenance	5	Combination of materials, material choice	5	Material analyses/calculations, anode/ACP	6	150
	Failure of system controls	Unpleasant op., decrease, personal injury	10	Sensitive system, misreading from sensors/mailfunction, Improper failsafe-mode	5	Tests and calculations	2	100
	Underwater noise	Harming maritime life -> no op. in certain environments	7	Hydrodynamic effects	6	Test, simulation	9	378
	Unwanted hydrodynamic effects	Unpleasant op.	5	Poor designed foil	5	Tests	5	125
	Biofouling (E.g. barnacles)	Increase drag (less efficiency)	5	Pores leading to bacteria	8	Minimise pores, utilise anti-fouling systems	5	200
	Personal injuries when stationed on shore	Personal damage/injuries	10	Sharp edges, crush hazards, large movement of system	3	Geometrical design/design/system routines with minimized crush hazards	1	30
	Mechanical/operation noise	Unpleasant op., unpleased customer	5	Poor mechanical solution design, hydrodynamic effects	3	Design, tests, prototype	2	30
Total								1527

Figure A.30: FMECA on the concept Odd Berit

FMECA	Potential Failure Mode	Potential Failure Effects	Severity (1-10)	Potential Causes	Occurrence (1-10)	Current Controls	Detection (1-10)	RPN
Description	What could go wrong?	Impact on the customer?		What causes it?		How can it be prevented or detected?		
Telescopic Concept	Pod breaks before foils	Malfunction of propulsion, personal injury	8	Foil in an impact with object	2	Structural weakness	1	16
	Foil does not break at impact	Malfunction of lift, unpleasant op., personal injury	10	Foil in an impact with object	3	Should not be prevented. Anyhow assure break at all speeds at proper impact, without harming user.	1	30
	Jack-knifing	Unexpected disruption in lift, unpleasant op. personal injury (roll, jack-knifing is worst)	10	Failure of AoA adjustment system	0	Assure Cp is behind Center of rotation at all AoA	1	0
	Cavitation	Noise during op. and unwanted erosion	4	To high speed/dynamic effects during op.	7	Physical testing	6	168
	Stalling	Loss of lift, unpleasant op.	6	To high/low AoA	3	Sufficient system control, geometrical design for comfortable stall characteristics	2	36
	Debris entanglement	Increase drag (less efficiency), loses all the propulsion	8	Insufficient geometrical design	5	Physical testing/sufficient geometrical design	4	160
	Corrosion	Break, decrease in efficiency, increased maintenance	5	Combination of materials, material choice	6	Material analyses/calculations, anode/ACP	7	210
	Failure of system controls	Unpleasant op., decrease, personal injury	10	Sensitive system, misreading from sensors/mailfunction, Improper failsafe-mode	4	Tests and calculations	3	120
	Underwater noise	Harming maritime life -> no op. in certain environments	7	Hydrodynamic effects	4	Test, simulation	9	252
	Unwanted hydrodynamic effects	Unpleasant op.	5	Poor designed foil	4	Tests	5	100
	Biofouling (E.g. barnacles)	Increase drag (less efficiency)	5	Pores leading to bacteria	8	Minimise pores, utilise anti-fouling systems	5	200
	Personal injuries when stationed on shore	Personal damage/injuries	10	Sharp edges, crush hazards, large movement of system	3	Geometrical design/design/system routines with minimized crush hazards	1	30
	Mechanical/operation noise	Unpleasant op., unpleased customer	5	Poor mechanical solution design, hydrodynamic effects	5	Design, tests, prototype	2	50
Total								1372

Figure A.31: FMECA on the concept Telescopic

S Second Subjective and Objective value matrix

Subjective, objective values	1	2	3	4	5
Efficiency (L/D) [-]	≥ 15	$\geq 17,5$	≥ 20	$\geq 22,5$	≥ 25
Spaciousness, Large in area-extent/spanwidth [sub/m]	1/1,4	2/1,25	3/1,1	4/0,95	5/0,8
Manufacturing complexity/specialization [sub]	high		medium		low
Weight of component [kg]	≥ 8	$\geq 7,25$	$\geq 6,5$	$\geq 5,75$	≥ 5
Complexity/increased capability of machinery [sub]	high		medium		low
Maintenance required (company/service) [sub]	high		medium		low
Technical feasibility (TRL) [level]	0	≤ 2	≤ 3	≤ 5	≤ 9
Risk for debris entanglement [sub]	high		medium		low
User satisfaction [sub]	low		medium		high
Risk assessment (FMECA) [RPN]	≥ 1500	≤ 1425	≤ 1350	≤ 1275	≤ 1200
Innovation [sub]	low		medium		high

Figure A.32: Second Subjective and objective value matrix of the criteria

T Second Pairwise comparison Matrix

Criteria		A	B	C	D	E	F	G	H	I	J	K	Sum	Weight
Efficiency (L/D) [-]	A	-	0,5	1	1	1	1	1	1	0	0	1	7,5	0,136
Spaciousness [-]	B	0,5	-	1	0,5	0	1	1	1	0,5	0	1	6,5	0,118
Manufacturing complexity/cost	C	0	0	-	1	1	1	1	1	0	0	0,5	5,5	0,100
Weight of component	D	0	0,5	0	-	1	0,5	1	0,5	0	0	0	3,5	0,064
Complexity/increased capability of machinery	E	0	1	0	0	-	0	1	0,5	0	0	0	2,5	0,045
Maintenance required (company/service/user)	F	0	0	0	0,5	1	-	1	0,5	0	0	1	4	0,073
Technical feasibility (TRL)	G	0	0	0	0	0	0	-	0	0	0	0	0	0,000
Risk for debris entanglement [-]	H	0	0	0	0,5	0,5	0,5	1	-	0	0	0,5	3	0,055
User satisfaction	I	1	0,5	1	1	1	1	1	1	-	0	0,5	8	0,145
Risk assessment (FMECA)	J	1	1	1	1	1	1	1	1	1	-	1	10	0,182
Innovation	K	0	0	0,5	1	1	0	1	0,5	0,5	0	-	4,5	0,082
Total:													55,0	1
Legend		0=Worse	0,5=Same	1=Better										

Figure A.33: Second Pairwise Comparison Matrix for calculating the factor of weights

U Concept validation - Behaviour of the foil

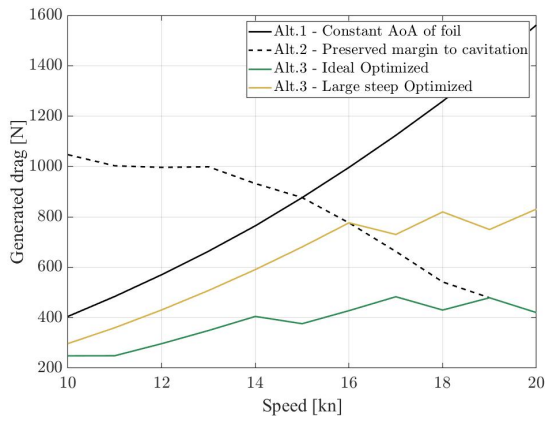

(a) Generated drag from foil at different running Alternatives and all speeds

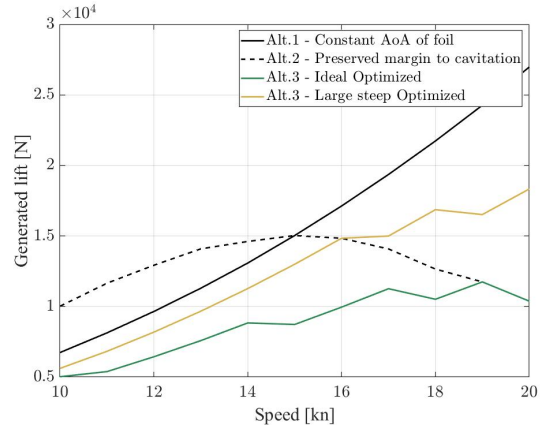

(b) Generated lift from foil at different running Alternatives and all speeds

Figure A.34: Generated lift from foil at different running alternatives and all speeds

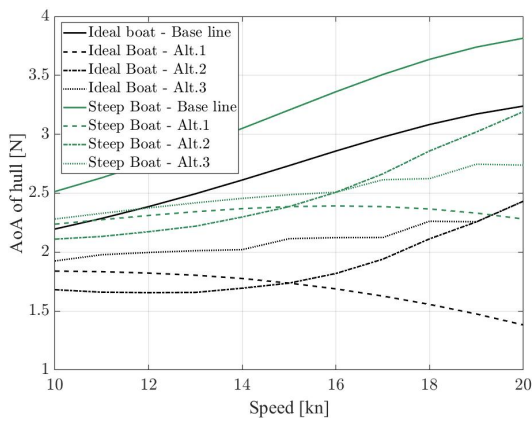

(a) AoA of foil at different running Alternatives and all speeds

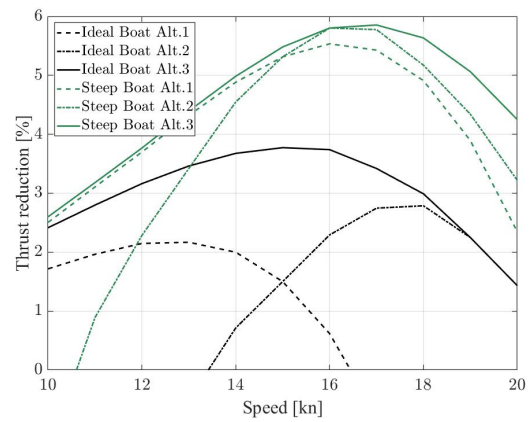

(b) Angle of Attack (AoA) of hull at all speeds

Figure A.35: AoA of foil and hull for different running alternatives and all speeds

V Concept validation - Behaviour of the hull

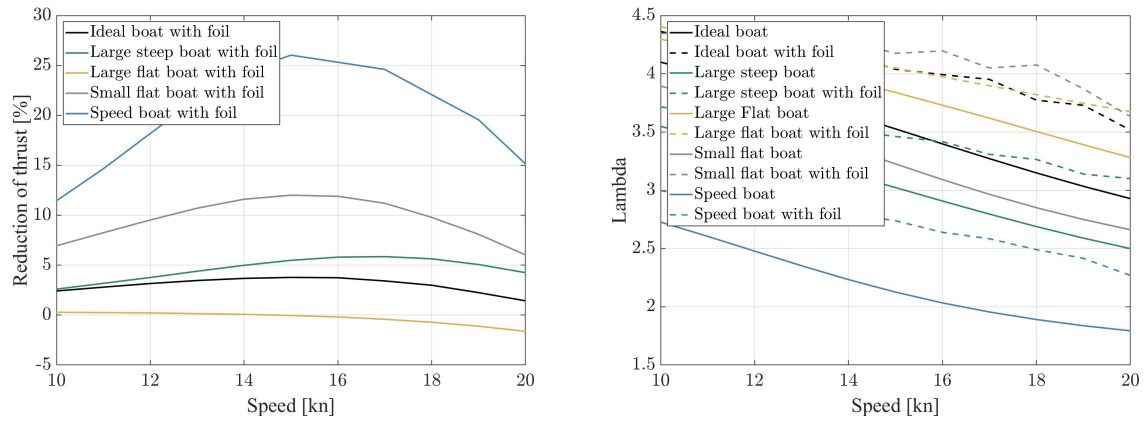

(a) Reduction of thrust for all hulls at all speeds, utilising Alternative 4 (b) Lambda values for all hulls as all speeds for Alternative 1 and 4

Figure A.36: Thrust reduction and lambda values for all hulls at all speeds

DEPARTMENT OF SOME SUBJECT OR TECHNOLOGY
CHALMERS UNIVERSITY OF TECHNOLOGY
Gothenburg, Sweden
www.chalmers.se



CHALMERS
UNIVERSITY OF TECHNOLOGY