

Infill

Industrial building transformation
with timber

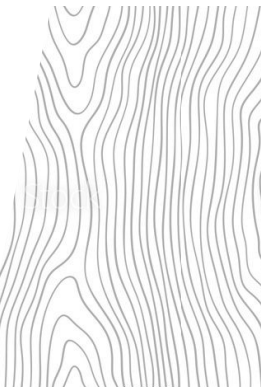
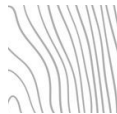
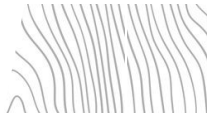

 Master Thesis  Yuren Chen
 2023  Chalmers School of Architecture
 Department of Architecture and Civil Engineering
 Examiner: Walter Unterrainer  Supervisor: Tina Wik

Acknowledgement

This work would not have been possible without the support of my supervisor Tina, who is always giving me positive energy and encouragement in the working process. Apart from her support of this thesis' goals and site decision, she has contributed many great ideas and knowledge regarding design out of her expertise in transformation and timber construction.

I'm very grateful to my examiner Walter, who has provided many helpful insights regarding the research and design methods and improved my work efficiency. With his help, my initial thesis goals got to be clarified, narrowed down and turned out more realistic and rational.

Particularly helpful to me during the beginning of the thesis was Annette Vejen Tellevi from Älvstranden, who shared with me valuable information and files about buildings under transformation process which laid the foundation for me to work on Plåtverkstaden. Special thanks to Sofia Wallin who offered me help while I was in my exchange university and unable to visit the area.

I would like to recognize the assistance that I received from Dinel Marinconi and his staff from BTT Rivningsspecialisten AB who is currently doing the cleaning work of Plåtverkstaden and supported my several site visits inside the building.

Many thanks to Hanna Johansson for the valuable feedback she contributed in the mid-seminar, which helped me to formulate my goals more accurately.

Most importantly, I would like to express deep gratitude to Vega, Huiting, and Laura, who accompanied and encouraged me including the time when I was low because of personal issues, and to my family and dear friends for their constant love, care and support.



CHALMERS
UNIVERSITY OF TECHNOLOGY

Infill - industrial building transformation with timber

Yuren Chen

2023

Chalmers School of Architecture

Department of Architecture and Civil Engineering

Architecture and Planning Beyond Sustainability

Examiner: Walter Unterrainer

Supervisor: Tina Wik

ABSTRACT

Key Words: transformation,
timber, disused industrial
buildings, housing, workspace,
comfort

Under the background of globalization and urbanization, Gothenburg grew into one of the largest Nordic cities, accompanied by a housing shortage. People wait for years in rental housing queues or move around frequently because of short-term contracts. The lack of housing makes it easier for people with stable work while disadvantages the mobile population like students and temporary workers. There is an objective need for a temporary-type accommodation model.

Meanwhile, the industrial section in Gothenburg has faced a recession and the need for urban transformation like in the Lindholmen area is being prioritized. Hence, transforming disused industrial buildings into new residential buildings to reduce new construction becomes an interesting topic for me. Plåtverkstaden near Lindholmen is chosen as the building to develop my thesis.

When thinking about transformation inside buildings, the first material that came into my mind is timber. Timber has many advantages concerning construction. It can be locally sourced, extremely light, fast to assemble, and can be customized easily at the site. It's low-impact and visu-

ally appealing, which matches the sustainable concept of transformation with a second-life metaphorical message.

When timber is infilled into an existing building envelope, thermal performance goals can be achieved much easier, which is one of the synergies triggered. Through this thesis, I hope to find out more synergies of transformation with timber.

This thesis is about transforming Plåtverkstaden with timber to create a lively community where people can live, work and connect, with a goal of supporting the companies and university in the vicinity with short-term housing and working services, so as to promote Gothenburg's industry transformation for a sustainable future in the urban context. To meet indoor comfort goals for living and working, comfort analyzing software is used as a design tool. Apart from that, exploration also includes the design of housing units with higher heights, and the potential for indoor gardens, re-using existing building elements, in the industrial building setting. This thesis is aimed to be a reference to show the potential of industrial building transformation and provide solutions for more cases.

THE

STRUCTURE FOR READING

TABLE OF CONTENTS

Introduction

About - What?
Purpose - Why?
Method - How?
Objectives &
Delimitations

Context

Götaverks - background
Älvstaden - Gotaverks -
future
Plåtverkstaden - info &
reality
Neighborhood mapping
People in Lindholmen
"Temporary"

Design

Scenario
Building Envelope
"Insert" Concept
Housing Unit Concept
Daylight Strategies
Site Movement
Elevation Transformation
Spatial Configurations
Workspace Concept
Re-use Existing Elements

Optimization

Optimization Focus
Daylight Measurements
Test Proposal 1
Test Proposal 2
Test Proposal 3

Timber

Selection of Timber
Systems
Construction Strategy
Atrium Acoustic Strategy

Proposal

Elevations
Plans & Sections
Housing Plans & Sections
Visualizations
Reflection

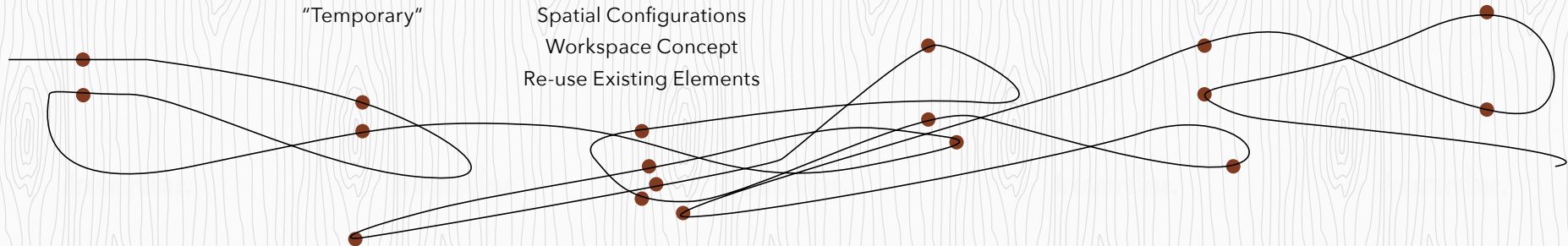

TRACE OF PROCESS

1.

WHAT? - ABOUT
WHY? - PURPOSE
HOW? - METHOD

OBJECTIVES & DELIMITATIONS

INTRODUCTION

ABOUT - WHAT?

What does the thesis work on?

The main content of this master thesis is to study how to transform Plåtverkstaden (it means "metal sheet factory"), a shipyard building built 70 years ago near the port of Gothenburg, into an attractive and comfortable temporary residential project, with sustainable strategies, that meets the needs of urban development. Mass timber is chosen as the main material for the new program.

- Narrative

The narrative of the thesis is composed of 6 chapters, in the order of Introduction, Context, Design, Optimization, Timber and Proposal.

Introduction chapter mainly introduces what the thesis topic is about, the motivation to choose the topic, and the method to do it, that is respectively, what, why, and how. The decision on the thesis topic is the out of my research interest towards timber and industrial buildings, which formed the initial ideas at the beginning of the thesis.

Context chapter describes the history and current situation of the shipyard company which Plåtverkstaden used to belong to. It introduces the positioning of the building in the city development plan from urban scale, and shows the "reality" of the building and its surrounding environment in combination with the site photos and architectural drawings. The chapter also analyzes the main target population of this housing project and puts forward the programmatic concept.

Design chapter is composed of those elements of case study, design strategy and design conceptual sketches, repeatedly. It shows a circuitous process of looking for design inspiration from the aspects of indoor comfort, building conditions and limitations, spatial quality, social values, and so on. Its purpose is to put forward a series of strategies from the perspective of architecture as the basis of design proposal, to show an attractive living environment, which generates corresponding design versions for the Optimization in the fourth chapter to test and improve the comfort performances, where daylight is the main focus.

Optimization chapter's content is as follows:
Test several design versions according to the strategy proposed in the Design chapter. (The selected software is Climate Studio, a plugin for Rhinoceros 3D, which is a fast and accurate environmental performance analysis software for the architecture, engineering and construction sector). Its simulation workflows help designers and consultants optimize buildings for energy efficiency, daylight access, electric lighting performance, visual and thermal comfort, and other measures of occupant health.)

Generate daylight comfort analysis through this software.

Propose corresponding strategies to respond to unsatisfactory analysis results and show the improvement results brought by these strategies.

Timber chapter adds in the design considerations from the structure and construction aspect and helps the design proposal go into the next level with more detailed dimensions. The choice of timber structure systems for distinct programs are discussed and the construction process is designed in respond to the existing building conditions. Material selection for flooring and facade of the filled-in programs are also included, based on visual and acoustics criteria.

Proposal chapter is the display of the final design scheme generated after adopting the improvement strategies and developed into a higher resolution. The final proposal focuses on the spatial quality and social value potentials of the solution optimized by comfort software at the architectural level. Details on how to reuse the existing elements in the building, as well as material selection and construction details will also be included in this section. Finally, the thesis ends with a reflection on the design process and a conclusion on this design project and more generally, on the transformation of industrial buildings into housing with timber.

- Questions?

You may have many questions: why should we transform industrial buildings? Why choose temporary housing as the new program? What are the challenges in transforming industrial buildings into housing function? Why use Timber as the main material? In the "why" section, I will introduce the intention and purpose of the thesis topic selection.

PURPOSE - WHY?

Why transforming old industrial building?

Most of the existing old plants have backward production capacity, outdated equipment and inadequate environmental protection measures. While demolition and reconstruction consume more resources, considering transformation and assign new missions of the current age to the existing building is a potentially sustainable way to solve the problem. The building itself is a resource, so the protection and recycling of old factory buildings are also the protection of urban environmental resources.

From the perspective of geographical location, old industrial buildings are sometimes of great economic value. Industrial cities often develop around its major industries. The city's territory is expanding and the land occupied by those old factories might actually turn into central locations with high land value. How those buildings in critical positions within the city are used today exerts an important influence on the city image.

From the perspective of real estate, the wide interior space and generous height conditions of some old industrial buildings,

provides extra freedom and playfulness for the repositioning of project functions. New organizations to meet personalized needs might even be achieved, so one can further explore its commercial value, and even develop innovative lifestyle concepts.

From the perspective of culture, the old factory buildings, as the remains of the historical development of an industrial city, are valuable windows to display the past culture and crucial carriers for the continuation of urban memory, especially when the major industries have been shifted. Under the background of Gothenburg's economic development driving forces' transformation and the industrial structures' optimization and upgrading, the old industrial buildings have become a powerful starting point to revitalize the existing space resources and promote cultural development. From industrial memories to the injection of innovative functions and formats, from old spaces to new landmarks, industrial building transformation can achieve cross-era cultural integration and collision, and contribute to the urban life richness and thickness.

Why choosing the program of housing?

- Globally

The increase of urban population resulting from the global urbanization process, particularly the increase of mobile population, highlights the need for more housing projects. As cities continue to grow, more people are moving to urban centers, leading to further unevenly distributed housing demands. This demand for housing is particularly acute for mobile populations, such as students, young professionals, and migrant workers, who require more flexible accommodation plans that tolerate changes and uncertainties. The lack of adequate housing not only puts a rein on urban development due to the capacity limitation for new talents, but also exacerbates issues such as homelessness and insecurity. Therefore, to address the challenges posed by urbanization, there is a pressing need to develop more housing projects to support the growing urban population.

- Sweden

As shown clearly in this chart, the population has increased

much faster than new builds over the past decade. This indicates that new builds have not been able to meet the needs of a rapidly-growing population.

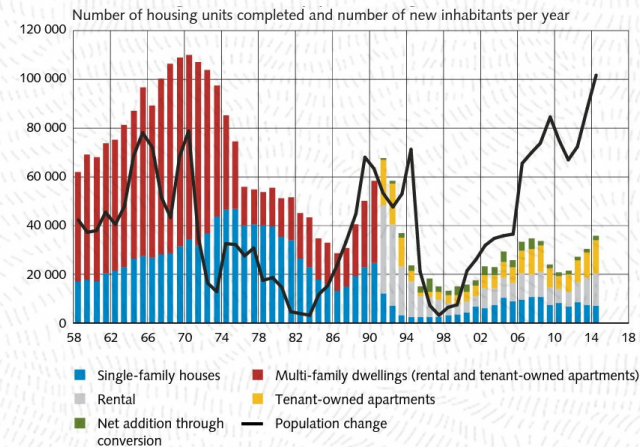

Note. Prior to 1991, it is possible to distinguish between different forms of occupancy in apartment buildings.

image 1. housing construction and population changes in Sweden
(Sources: Statistics Sweden and the Riksbank)

“With a lack of new construction since the 1990s, the Swedish housing market is facing a severe housing shortage. Moreover, there is a fundamental mismatch between where much of supply is located and where the demand is concentrating. Much of the public housing stock is in small towns with high vacancies, while the country continues to urbanize rapidly with limited new production in larger cities.” -- “Housing in Sweden: An Overview”

Why building for new housing near technology innovation area? Why temporary housing?

For those two questions, you will find answer in the Context chapter.

What are the challenges in transforming industrial buildings into housing function?

Industrial buildings, especially those with a large-span, are built for machine operations or goods storage, instead of human. However, housing is based on human-centered design, where indoor comfort is the fundamental objective. To transform industrial function into housing function, is to create an indoor comfort environment from a neglected status.

Looking at architectural plan layouts, residential buildings are normally very “thin-shaped” for good ventilation, natural light access and good view. Paradoxically, industrial buildings have much more “thick-shaped” plans. Hence, for a transformation project of housing program, how to resolve the contradiction between existing industrial building shape and the daily need for light and wind is the main challenge.

Industrial buildings normally have very limited proportion of openings on the façades. To adjust the potential of successful transformation, it is important to check about the flexibility of

adding openings to the facade. For example, it is comparably easier to add openings in a transformation when the building has a frame structure and the facades are not protected. It turns trickier or to say, less free, when the façade is load-bearing wall, or when the façades are protected out of historical reasons.

The challenge is also the purpose of this thesis, to explore the possibility of such transformation, with the help of design strategies. Through a series of intervention, the building is presented in a very different nature compared to its past appearance. The experience of living in such a building is shown through architectural drawings and renders, while the comfort performance, primarily the daylight performance, is examined by comfort analysis software.

Why use Mass Timber

- as the material in a transformation project?

- Light-weighted

Timber is much lighter by volume than concrete and steel. This means when transforming and densifying an existing building, timber has the minimum impact on the existing foundation, which reduces preparation works and costs. Meanwhile, more efficient assembly can be achieved as timber is light to hoist and install, with a relatively small crane, which is good for a transformation project if the envelope gives certain limits to the construction site management.

- Timing

Mass timber are extremely fast to assemble, and this reduces the construction duration and cost significantly. On the other hand, making last minute adjustments is easier and cheaper on site with timber, compared to other materials, considering the old existing building might have unexpected unpreciseness or situation during the intervention. The material can be adjusted with traditional hand tools and made fitting of utilities easily, such as drilling a hole for electricity.

- Envelope

The existing building provides an available envelope to shelter the new timber units inside. This makes timber design much more flexible since the proofing and insulation considerations are easier to achieve. This can reduce the cost of timber construction furthermore. For construction on the other hand, the existing envelope acts as the weather protection, which ensures the quality and reduces the complexity of construction.



- Metaphoric

Timber is visually appealing, and can contrast strongly with the original industrial character, which brings the industrial building an aesthetic touch of warmth and coziness. And since it is a natural grown material, it can suggest a "growing", "second-life" metaphorical message.



Why use Mass Timber

- as building material generally?

- Sustainable

Timber is highly praised for being environmentally-friendly and a renewable resource compared with other building materials. Forests in Sweden are managed according to sustainable principles which means that the extraction does not exceed growth, and when the wood returns to eco-cycle there are no added harmful GHG emissions. Also, the production of mass timber is an energy efficient process, while the by-products like wood waste can become fuels for the manufacture process, so the production can be less dependent on fossil fuels.

- Cost effective

As mentioned in the "Timing" aspect, there are significant savings from costs such as scaffolding, site accommodation, and construction site administration, as mass timber can be pre-fabricated and rapidly assembled, requiring much less labor on site, needing much less on-site tools and materials, and producing much less on-site wastes which also saves the spending of

transporting the wastes. Speaking of transportation, the lightness of timber also saves energy for logistics. The main concern is the collaboration between designers, builders and suppliers, as mistakes found on site might lead to weeks of construction delay due to the re-fabrication from factory and logistics.

- Strength

Mass timber products like cross-laminated timber (CLT) has high load-bearing capacity. Its compressive strength is similar to that of concrete, while tensile strength might even outperform steel when it comes to breaking length. It can also manage large spans and provide design freedom when it comes to layout.

METHOD - HOW?

how I have worked?



Program

form the program and list comfort and social qualities i need for different programs



3D Model

build a detailed model to work on to show what is the existing and what are the changes made.

Quality

create the life quality that can attract people to live here, using architectural strategies, spatial concepts and diagrams



Optimization

test with software and optimize the design through iteration, come up with strategies to improve the results

Timber

design for indoor comfort environment considering timber dimensions and strategies, draw plans and sections



Proposal

continue with optimized results and come up with design proposal with final resolution of renders and construction details.



 **Reference studies**
throughout the process

THESIS QUESTIONS & OBJECTIVES

Thesis Question:

“how can Plåtverkstaden be transformed with timber structures to create a lively community where people can live, work and connect, with the aim of supporting the companies and universities in the vicinity with short-term housing and working services?”

- Spatial Objectives:

- *timber units fit in harmony with the original structure visually and suggest a clarity for different functions.*
- *Novel spatial experience for shared common spaces.*

- Comfort Objectives:

- *Good daylight performance for both housing and working space.*
- *Fresh air for housing units.*

- Social Objectives:

- *an atmosphere like a collective home for all the temporary tenants.*
- *logical circulation to differentiate privacy and publicity.*

- Construction Objectives:

- *construction for the added units is easy to achieve.*

DELIMITATIONS

- Yes

- *focusing within the building itself, architectural scale*
- *strategies to improve indoor comfort like daylight, thermal, acoustic, and ventilation.*
- *quantitative comfort analysis of building performance with a focus on daylight .*

- No

- *the city planning and urban transformation strategies would not account for a big part of the design.*
- *there is no discussion of economic sustainability within the project.*
- *there is no quantitative thermal and ventilation analysis.*



GÖTAVERKS - BACKGROUND
ÄLVSTADEN - GOTAVERKS - FUTURE
PLÅTVERKSTADEN - INFO & REALITY
NEIGHBORHOOD MAPPING
PEOPLE IN LINDHOLMEN
"TEMPORARY"

CONTEXT

image 2. view from next to Plåtverkstaden towards the Älv river.
Photo: Y. Chen

*Port of Gothenburg,
the gateway to the world*

Historically, Gothenburg was home base from the 18th century of the Swedish East India Company. From its founding until the late 1970s, the city was a world leader in shipbuilding, with such shipyards as Eriksbergs Mekaniska Verkstad, Götaverken, Arendalsvarvet, and Lindholmens varv. The city has been ranked as the 12th-most inventive city in the world by Forbes.

GÖTAVERKS - BACKGROUND



image 3. Advertisement for
Shipbuilder Götaverken,
Gothenburg. (Götaverken, 1934)

Glorious History

AB Götaverken was a shipbuilding and industrial group in Lundbyvassen at Hisingen in Gothenburg. During the 1930s it was the **world's biggest shipyard** by launched gross registered tonnage. It was founded in 1841, and went bankrupt in 1989. During the first 100 years it was built at the Gothenburg shipyard; 605 vessels, from simple barges, steam sloops and sailing yachts to warships, passenger and merchant ships of all types, special vessels, cargo boats, bulk carriers, liners and tankers.

Crisis

In the second half of the 1900s, a shipyard crisis hit Gothenburg hard. The shipbuilding industry was gradually liquidated in Gothenburg from one of the town's largest employers. The last remaining part of the yard was a repair yard, which from 1993 went under the name Götaverken Cityvarvet AB . In 2000, the business was taken over by the shipyard group Damen Group based in the Netherlands . The yard was closed in 2015.

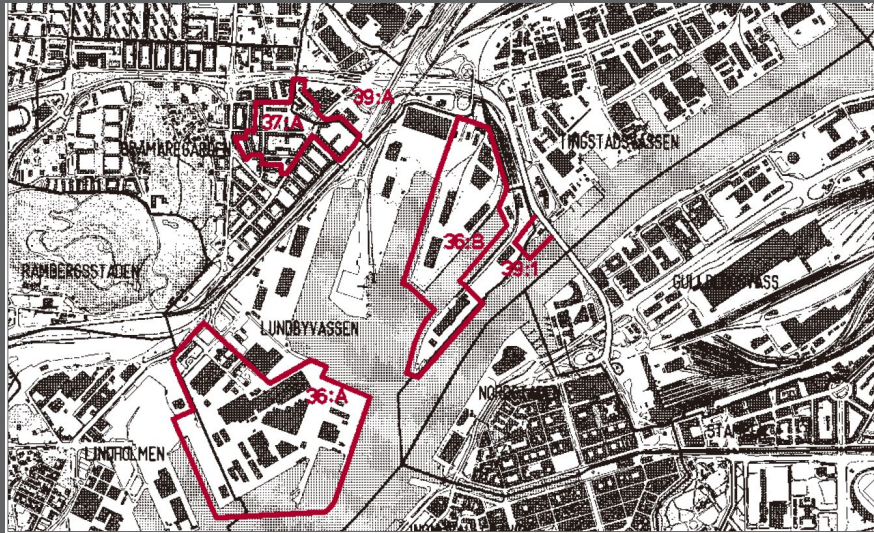

image 4. GÖTAVERKEN/
CITYVARVET, 36:A
FRIHAMNEN, 36:B
KVILLETORGETMM, 39:A
SEBRÅMAREGÅRDEN, 37:A
RODDKLUBBENS HUS, 39:1



image 5. Lindholmens varv,
Göteborg. Varvet 1961-10-
03. OWNER OF COLLECTION
SJÖHISTORISKA MUSEET

Current Situation

The city of Gothenburg is praised for its success in developing the areas where the shipbuilding industry had once been located, and new districts such as Eriksberg, Sannegården and Lindholmen were built around the old shipyards and industrial buildings.

Many of Götaverkens buildings are in the list of "KULTURHISTORISKT VÄRDEFULL BEBYGGELSE I GÖTEBORG" protection and in the plans of future transformation. They're owned by Älvstranden Utveckling which is a municipal real estate company. The company is positively working on several Götaverkens buildings' transformation for new public functions.



image 6. map from Lantmäteriet



N 6401577

E 316977

image 7. map from Lantmäteriet

0 400 800 1200 m
Skala 1:14 800. SWEREF 99 TM, RH 2000.

N 6398956

E 320076

LANTMÄTERIET

ÄLVSTADEN - FUTURE DEVELOPMENT

Älvstaden - "the river city" plan

"...Älvstaden is the Nordic region's largest urban development project. Central Gothenburg will grow to double its size when Älvstaden spreads out on both sides of the river. By healing the city, meeting the water and strengthening the regional core, we create an inclusive, green and dynamic city that is open to the world.

Along both sides of the Göta river, the goal is a vibrant and attractive inner city with 25,000 new

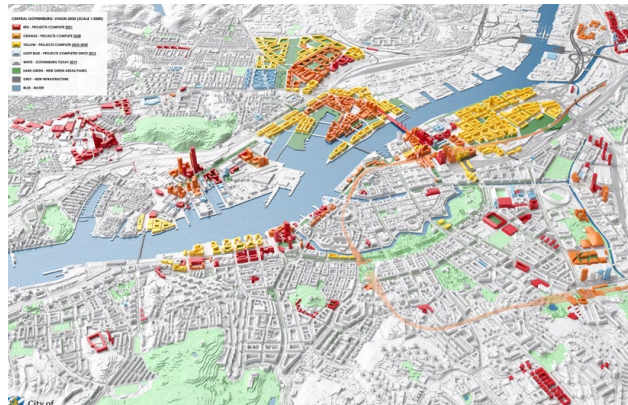

image 8. future central Gothenburg's buildings. From Göteborgs Stad.

apartments and 50,000 new workplaces. Älvstaden includes Backaplan, Centralen area , Frihamnen , Gullbergsvass , Lindholmen , Ringön and Södra Älvstranden .

The City of Gothenburg has decided to use Älvstaden as a test arena where we try out new models and technologies - socially, ecologically and economically. At the same time as we plan for Älvstaden in a long-term perspective, we must make the area accessible - here and now - through temporary

measures and activities.

The development towards an increasingly diversified and robust economy is stimulated, which in the long run can strengthen the entire region in the face of future challenges. Both people and businesses from Sweden and the rest of the world should be attracted to Gothenburg. A good urban environment with international lighting power and freed driving forces becomes a lever for the regional core as well."

- Göteborgs Stad



image 9. aerial look of central Gothenburg, From Göteborgs Stad

Red = 2021, Orange = 2028, Yellow = 2035-2050, Light blue = Projects completed since 2012. White = Existing buildings, Dark green = New parks/green areas, Gray = New infrastructure, Blue = Water.

GÖTAVERKS - FUTURE SCENARIO

Lindholmen

"...Lindholmen was originally a shipyard and industrial area that today is dominated by companies, educational and research institutions. It is lively during the day, but quieter in the evenings and weekends. The City of Gothenburg is working on a program for Lindholmen. One of the goals of the work is to connect the area with the inner city on the other side of the river and to supplement the area with additional housing, offices and preschools. A livelier district will gradually emerge

where businesses and education share the space together with housing, culture and restaurants. In addition, Gothenburg's tallest buildings will be located on Lindholmen and redraw the city's skyline, where the Karlatornet with its 245 meters will be the tallest building in the Nordic region.

Until 2027, a total of 2,700 new homes and 3,500 workplaces are planned for Lindholmen. There are also plans for a school for approximately 500 students in grades 4-9."

- Göteborgs Stad

Götaverks into Tech-Incubator

"Götaverken's old shipyard area on Lundbystrand in Gothenburg gets new life and purpose. We have developed the concept for the physical environment for The Yard - the new arena for small, new and growing tech companies in Gothenburg. The focus is to transform the old workshop halls with simple means and thus complement the strong innovation cluster that already exists at Lindholmen."

- Semrén and Månsson



image 10. aerial look of Lindholmen, From Göteborgs Stad



image 11. "The Yard" Conceptual Design from Semrén and Månsson

PLÅTVERKSTADEN

- CHOSEN BUILDING FOR TRANSFORMATION

History of Plåtverkstaden

Plåtverkstaden from the shipyard period in Lindholmen was built in 1954. The marine-use sheet metal workshop (Idrottshallen) is the place where the large steel sections that the ships were made of were welded.

It is a large complex oriented towards the former ship berths. It is built with a concrete frame, facades of reddish-brown brick and windows divided into small panes. The long facade to the east is an important eye-catcher from the river.

Current Plan for Transformation

Part of Plåtverkstaden has already been transformed and occupied with offices and a sport hall. The empty part of the building, which is my selected building for this thesis, will be transformed into new work space and workshop. Älvstranden, the municipal company that owns the shipyard buildings, are waiting for the contract with the future tenant so they can start the transformation. Currently a cleaning company is working on-site to clean off the interior brick walls as well as replace the polluted soil under the floor.



image 12. Building Location Within Gothenburg

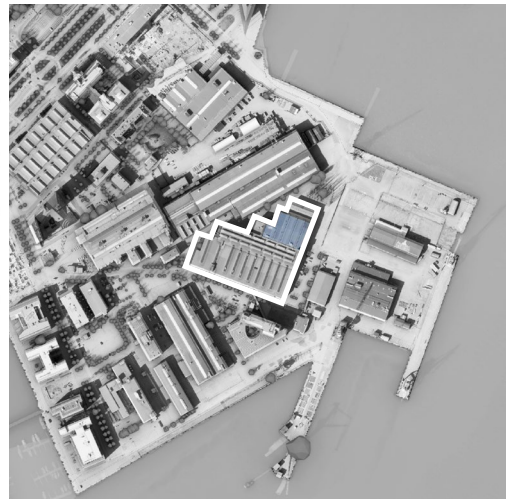

image 13. Location within Götaverks area



image 14. Plåtverkstaden

Reality - Outside



image 15



image 16



image 17



image 18



image 22



image 21

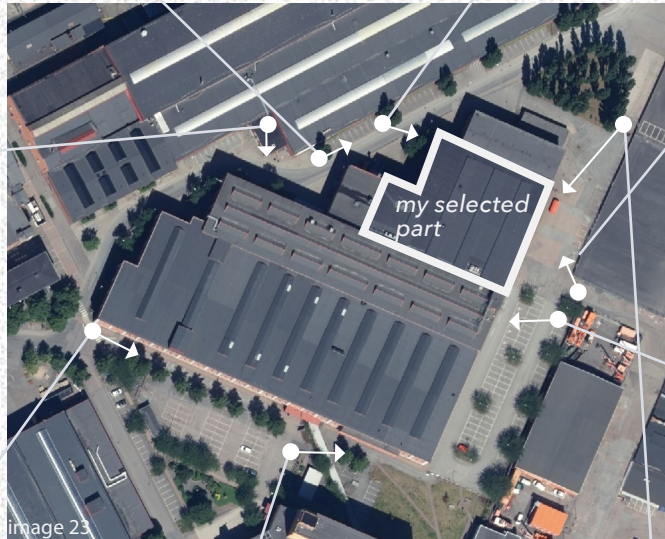

image 23



image 20



image 19

image 15,16,17,18. on-site pictures Photos: Y. Chen
image 19,22. pictures of Plåtverkstaden from Ävstranden
image 20,21. screenshots from Google Map
image 23. screenshot from Google Map

image 37. mapping of neighborhood functions

Plåtverkstaden is located in an intelligence-dense, innovative neighborhood with many workers, researchers and students. The Chalmers University campus and Lindholmen Science Park are within ten-minute walk. There are several student accommodations nearby.

It is worth noting that , within 6-minute walk from Plåtverkstaden, there are two hotels of more than 519 rooms in total, which indicates the socializing and housing needs for mobile population nearby.

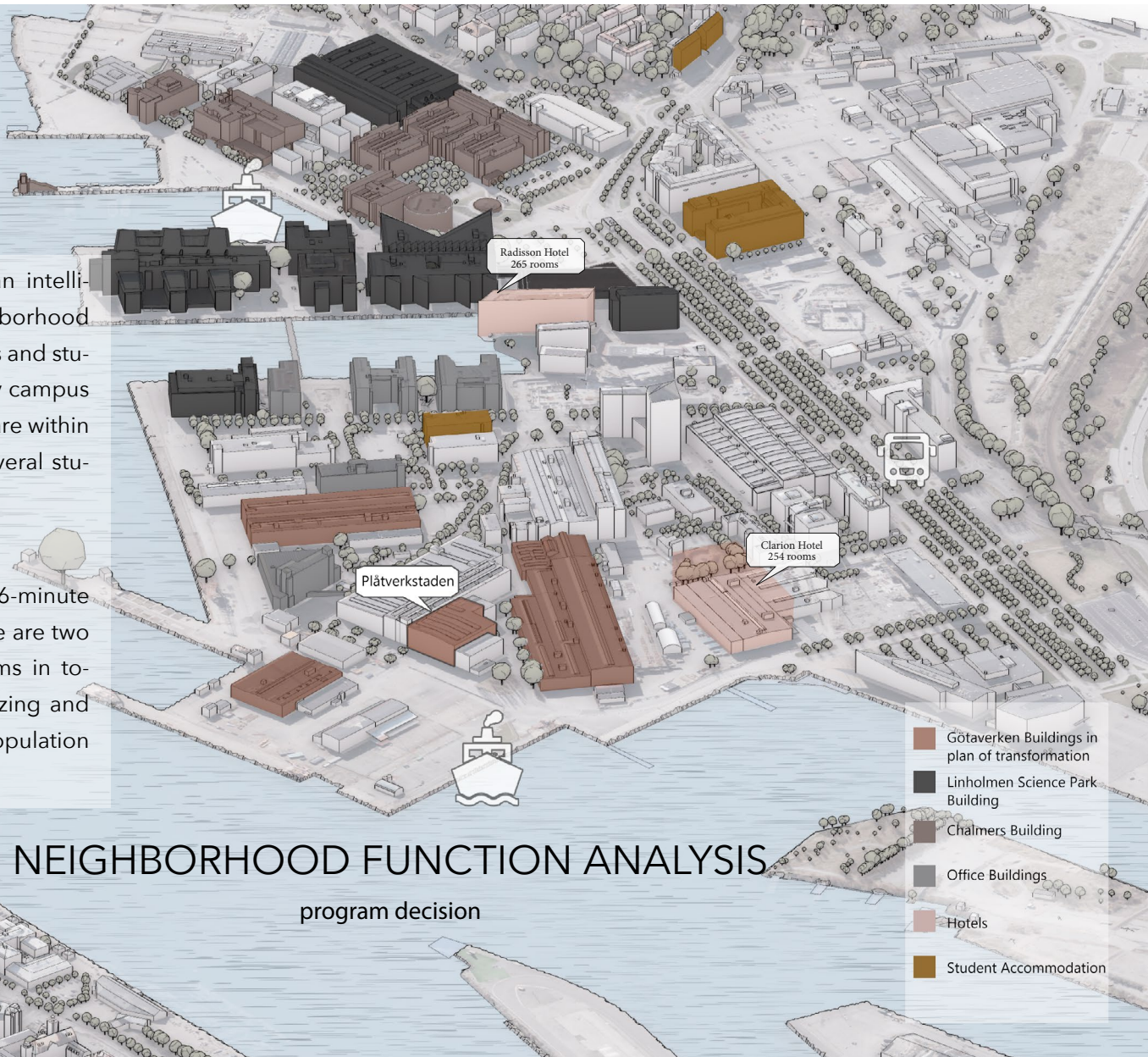

NEIGHBORHOOD FUNCTION ANALYSIS

program decision

LINDHOLMEN SCIENCE PARK

the Heart of Innovation

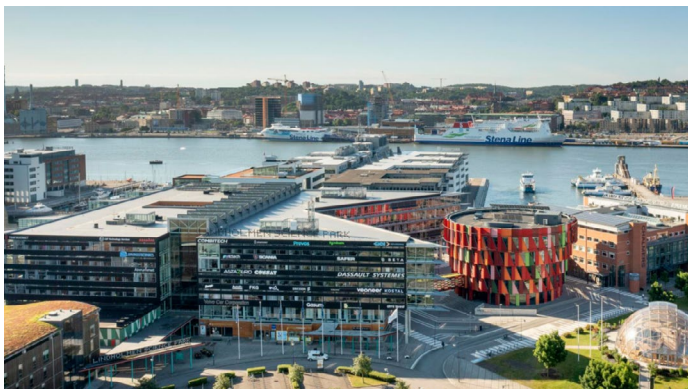

image 38. aerial look of Lindholmen Science Park

... where international talents meet and collaborate.

“Lindholmen Science Park was created twenty years ago by a group of bold decision-makers in trade and industry, politics and academia with the aim of building a better future for Gothenburg. Back then, it revolved around turning the former shipyard area into an attractive place for companies, organisations, students and residents.”

Lindholmen Science Park in Gothenburg is co-owned by Chalmers University of Technology, the City of Gothenburg, and industry among which the largest shareholders are companies like Volvo Group, Saab, Ericsson and so on. As a non-profit organization, its mission is to enhance Sweden’s competitiveness by focusing on future mobility for people and goods. Projects and researches are based on collaborations between academia, the industry community and the public sector.

Why building for new housing near technology innovation area and why temporary housing?

Lindholmen has an extremely dynamic population. Except for university students, short-term researchers and mobile scholars, currently there’re 375 companies in Lindholmen Science Park, and the number is still growing. Young professionals, and temporary workers such as consultants, specialists, contract workers, interns, freelancers, etc, composing a considerable amount of mobile population here that will need a place to live for a short period.

For tech companies, hiring temporary worker is inevitable. A ManpowerGroup Talent Shortage survey in 2012 noted that 49 percent of U.S. employers struggle to fill mission-critical job vacancies, and IT positions - along with engineering and similar skilled trades - continue to rank among the top 10 hardest jobs to fill. From a 2023 interview with the British recruitment company Hays, almost 95% of employers looking for tech talent have encountered a skills shortage over the past year.

The need for temporary employees might even increase in the post-Pandemic time. This is because after scaling back on workforces during the Pandemic economic downturn, different sizes of companies are trying to meet rising workload responsibilities, but often not ready to add full-time staff with position benefits.

Those employees, researchers, students, might stay here temporarily, from a few months to one or two years, or decide to settle down afterwards. It’s important to accommodate them in order to draw more talents into the city.

TEMPORARY

definition and re-programming

- "Temporary"

Q: what does it mean in the transformation of Plåtverkstaden?

A: Time frame. The period that one lives here is short than in a normal housing, and longer than in a hotel, between a few months to one year.

There are two influences that the "temporary" concept introduced will bring:

1. As tenants only live here temporarily, the solutions can be more flexible concerning accessibility and comfort. This encourages the transformation since conflicts between an industrial building and housing are allowed to be resolved in more creative and alternative ways, which lowers the threshold for the transformation to happen.

Case study - "Part-time Home" in Stockholm

It can be very expensive for a company to find rooms for employees currently working in Stockholm. The apartment hotel Part-Time Home helps both companies and individuals with temporary accommodation for a good price. Temporary workers, as well as local workers like builders, have been able to commute in an easy way.

- "80 percent of our customers are companies that need temporary housing for their staff", says Ida Kahn, CEO of Part-Time Home.

2. New programs are affected. "Temporary" means that the building accommodates an ever-changing group of people who are generally young, innovative, and live on their own. To maximize the short-term experience and encourage social life, and even incubate potential collaborations to formalize, the aim of the added programs other than housing units becomes stimulating new connections and interactions between the tenants.

What style of working will the future embrace?

The call for paradigm-shifting workspace design is strong nowadays. For jobseekers, increasing attention is paid to flexible working, especially in the post-Pandemic time. According to Hays' survey, there're several priorities that persuade jobseekers to land on a job, among which "Flexible working" turns out a big draw, with 46% of respondents hoping to get a hybrid role and 43% seeking a fully remote role.

- Re-Programming

Based on the popular "flexible working" style mentioned above, there is an opportunity to combine housing and workspace inside one building, so that people living here can socialize better through the working and collaboration spaces, while they also work more adaptably for the flexibility of working next to home. Restaurant, bar and cafe can be added in the shared spaces to create a coherent and independent working experience.

Workspaces inside Plåtverkstaden can also serve people who do not live here. During the day Lindholmen is spirited and vibrant, however it turns dismal and lifeless during the night as the area becomes empty when workers finish the day and leave. Imagine Plåtverkstaden becomes a free place where you can go to work and chill, and there is always people around forming a cozy community! It is as welcoming and bright as a big lighthouse on the river. And so the liveliness in Lindholmen from daytime has a continuation.

SCENARIO
BUILDING ENVELOPE
"INSERT" CONCEPT
HOUSING UNIT CONCEPT
DAYLIGHT STRATEGIES
SITE MOVEMENT
ELEVATION TRANSFORMATION
SPATIAL CONFIGURATIONS
WORKSPACE CONCEPT
RE-USE EXISTING ELEMENTS

DESIGN

3.



image 39. Initial sketch

image 40-44. on-site pictures. Photos: Y. Chen

BUILDING ENVELOPE

current conditions

The building envelope has a stunningly generous size on each opening, with strong industrial characters.

There are several huge gates on the south and north elevations, which can provide convenience and freedom for the transformation construction work, as well as bring in plenty of daylight when they're opened.

The windows are much taller than normal windows. The smallest windows of Plåtverkstaden are 2-meter high.

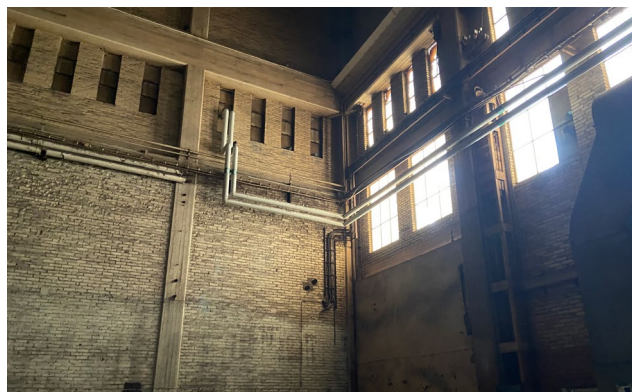
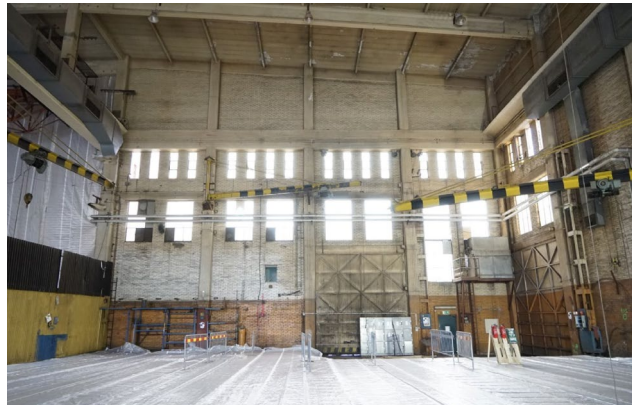

There are no openings on the west wall and east wall as they're shared with two neighbor buildings on both sides. The east brick wall has many window openings directly connecting the views into the neighbor building hence new insulation and veneers are needed for this wall. The west wall is covered by metal sheets, which I hope to keep for the industrial feeling while fill the inside with enough insulation.

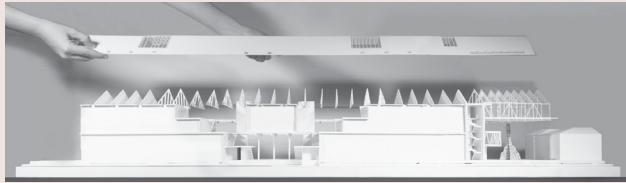
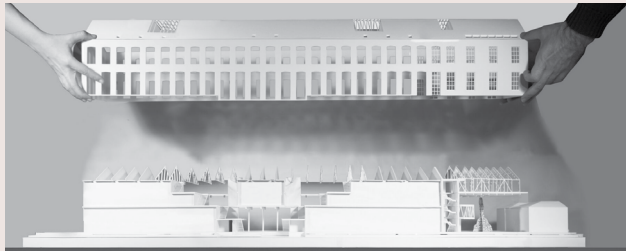
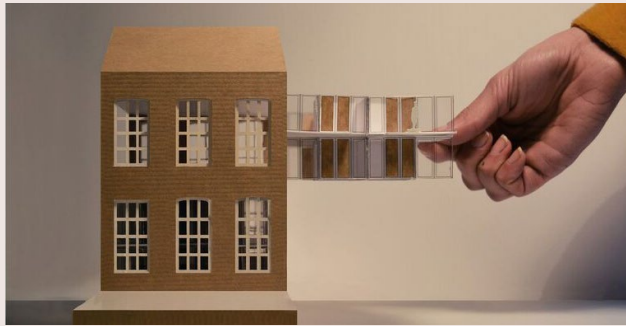

Case study - Industrial Heritage Transformation into Housing with Timber

The old thread storage building was built in 1905 and destined for storage. The project includes 46 housing units, among which 41 units are for youngsters and 5 units are temporal residence for artists.

The new construction is a dry construction by assemblage with just few materials, timber is the major material. Wood is used in all its forms, such as solid, agglomerated, cross laminated... The new construction can be assembled and disassembled, so it is “reversible” and the building can return to its original form of 1905 in the future with the added units being recycled.

The two inner floors of the building, are re-used without any reinforcement because of the lightness of added timber units. Façade and roof of the building act as a thermic buffer for the housing units, which are placed offset from the façade, with a second wooden façade, to allow for natural ventilation and shading in the hot summer of Barcelona. The housing units do not require the air conditioning the most part of the year.

The communal spaces are created for socializing, where the exchange of ideas and the common use of spaces become everyday life of the tenants.



image 45-48. pictures from project “46 Dwellings in the Former Fabra & Coats Factory / Roldán + Berengué.”

HOUSING CONCEPT

- INSERT TIMBER UNITS

Independent Timber System

- Housing units Distribution

Housing is the most prioritized program in this transformation project. Hence, in order to acquire natural ventilation and daylight in the housing program, the limited openings on the facade should be utilized to the maximum. An independent timber system is proposed, to have the new timber units placed directly against the existing brick wall, so that tenants have access to fresh air. There can be 30mm gap between the housing units and the existing brick wall, to make the constructions easier as the brick walls are not 100% smooth, also to avoid transport of humidity.

- Light-weight

CLT is chosen as the housing units material. Its lightness and load-bearing strength, allows a rapid construction assembly by stacking the timber units.

- Thermal buffer & indoor climate

There are two sides of Plåtverkstaden that do not have any openings because of the neighboring buildings. For the two facades with big openings, the housing units which locate directly against those facades, can be a thick thermal buffer for the big atrium volume. And because timber is a material that breathes and maintains an active relationship with the temperatures and humidity, the housing units contributes to a good indoor climate in the atrium at the same time.

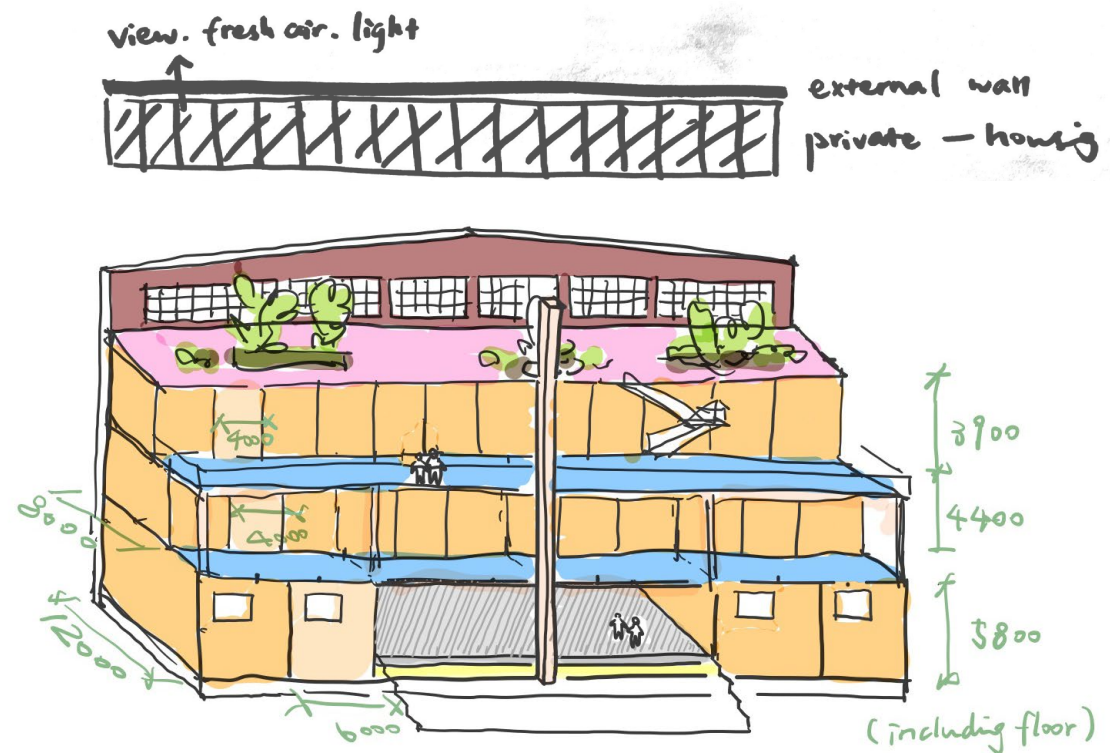

image 49. sketches of housing units concept



image 50-53. pictures from the project "Light-filled duplex offers small design with huge impact in NY."



Case Study

- Light-filled duplex offers small design with huge impact in NY

A renovation of a one-bedroom duplex in New York City is completed. The interior of 675 square foot space is flooded with light, thanks to the dramatic arched window on the exterior wall. The renovation includes reconfiguring the space, installing a zebrano plank flooring on both levels, and customizing a steel staircase that cantilevers and folds to the upper level. The upper level selects a sandblasted glass railing that keeps the privacy while still allowing natural light to filter into the bedroom.



HOUSING UNIT STRATEGY - LOFT

natural light & privacy

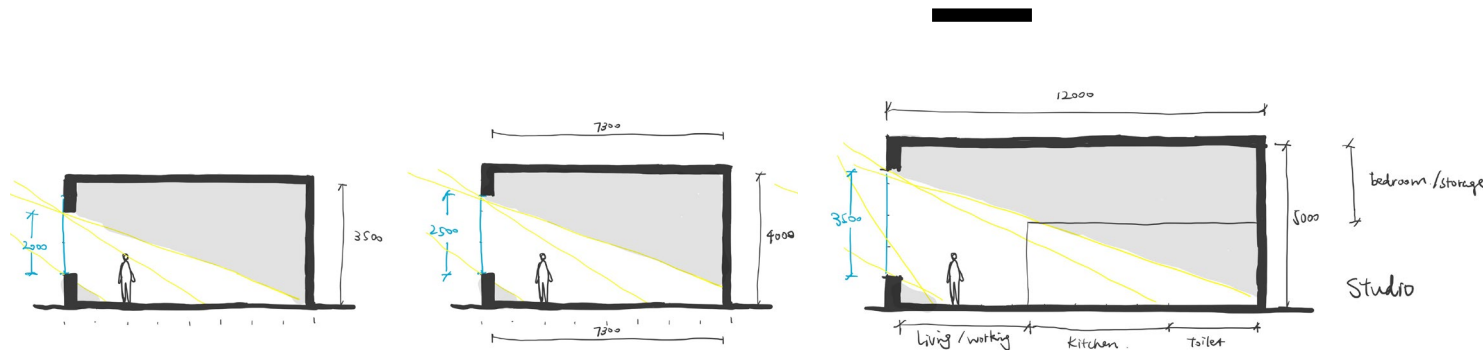

image 54. sketches of daylight and privacy strategy

Opening that adapts to the exterior wall

The existing facade of Plåtverkstaden features stunning high windows, with dimensions of 2-meter and 2.5-meter heights. According to the proportion, on the first floor I add openings with the same width as the second and third floor windows, and choose the height of 3.5-meter to give a 2-2.5-3.5 gradual proportion sequence.

The size of the window is much bigger than normal dwelling window sizes. It suggests one potential: with higher window, the room can be deeper as with the same angle of incidence of the sun, higher window allows for bigger illuminated area. This is an extremely helpful point for the housing units, since the total number of openings is fixed, with bigger depth of units, they can accommodate more program now.

How to utilize the interior height? The case study provides an insight: for industrial buildings with high windows, duplex with an upper floor is a good solution to remain the drama of the space while include more program and have a private zone in the upper floor.

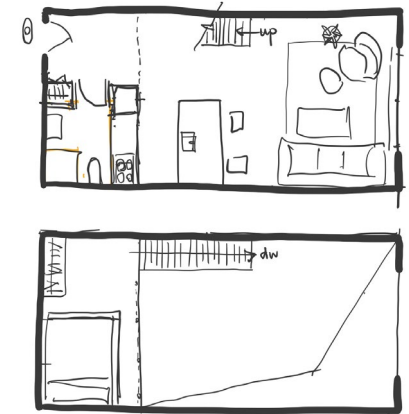

Privacy

By lifting the bedroom to the upper floor, privacy is much more protected. This is particularly important for the housing units on the first floor facing the street. Privacy can be further enhanced by introducing glass railing that allows in natural light but not seen through.

Case Study - Sheet metal factory transformed into Housing

A circular "drum" is inserted brutally in the plan to invite daylight in. The drum forms a courtyard, which turns into a lantern and a lung for the adjacent interior spaces.

This project presents how a one big gesture, the "drum"-shaped void, can direct each subsequent aspect of the buildings organisation and detail. The intervention amplify the rawness, scale and history of the existing shell: enabling domesticity in this formerly industrial building.

image 55,56. Fitzroy Sheetmetal Factory | Koolhaas

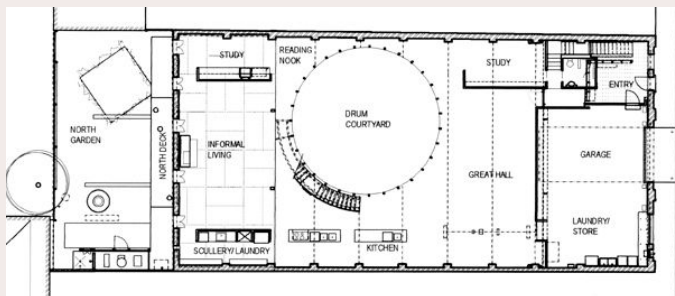

ATRIUM COMFORT STRATEGY - A LANTERN & LUNG

introduce daylight, ventilation and nature

- Skylight: Daylight & Ventilation

Skylight is the most important chance for Plåtverkstaden to get more natural daylight and fresh air. Since the freedom of adding openings on the facades is limited out of structural and protection reasons, adding the fact that Plåtverkstaden is sandwiched between two building, the roof becomes the only structure of the envelope that allows generous flexibility of transformation.

- Winter Garden - socialize with Nature

Since the factory was used for ship-building function before, there is more than 1 meter space under the current floor slabs, which gives the room for the earth that an indoor garden would need.

Combining this condition with the atrium skylight strategy, a winter garden can be created and bring in new life into this old industrial building. The atrium is high enough to allow plants of different heights to grow, under sunlight from above. Except for turning the atrium into a pleasant space to socialize and relax, the winter garden can also be an buffer element for spaces needing more privacy, like the housing units.

Inspirations



image 57. "the Winter Garden"

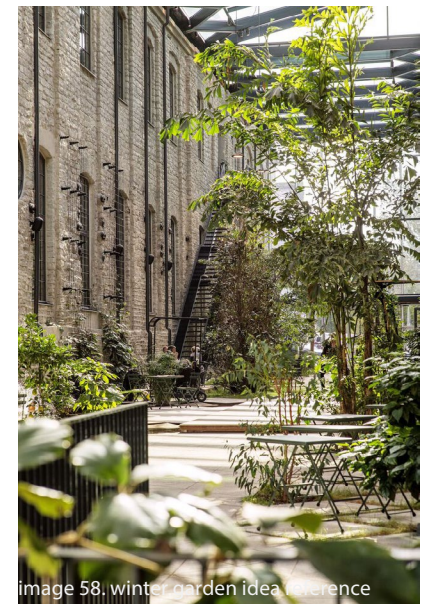

image 58. winter garden idea reference

INITIAL SPATIAL CONCEPT

sketch of the massing and facade

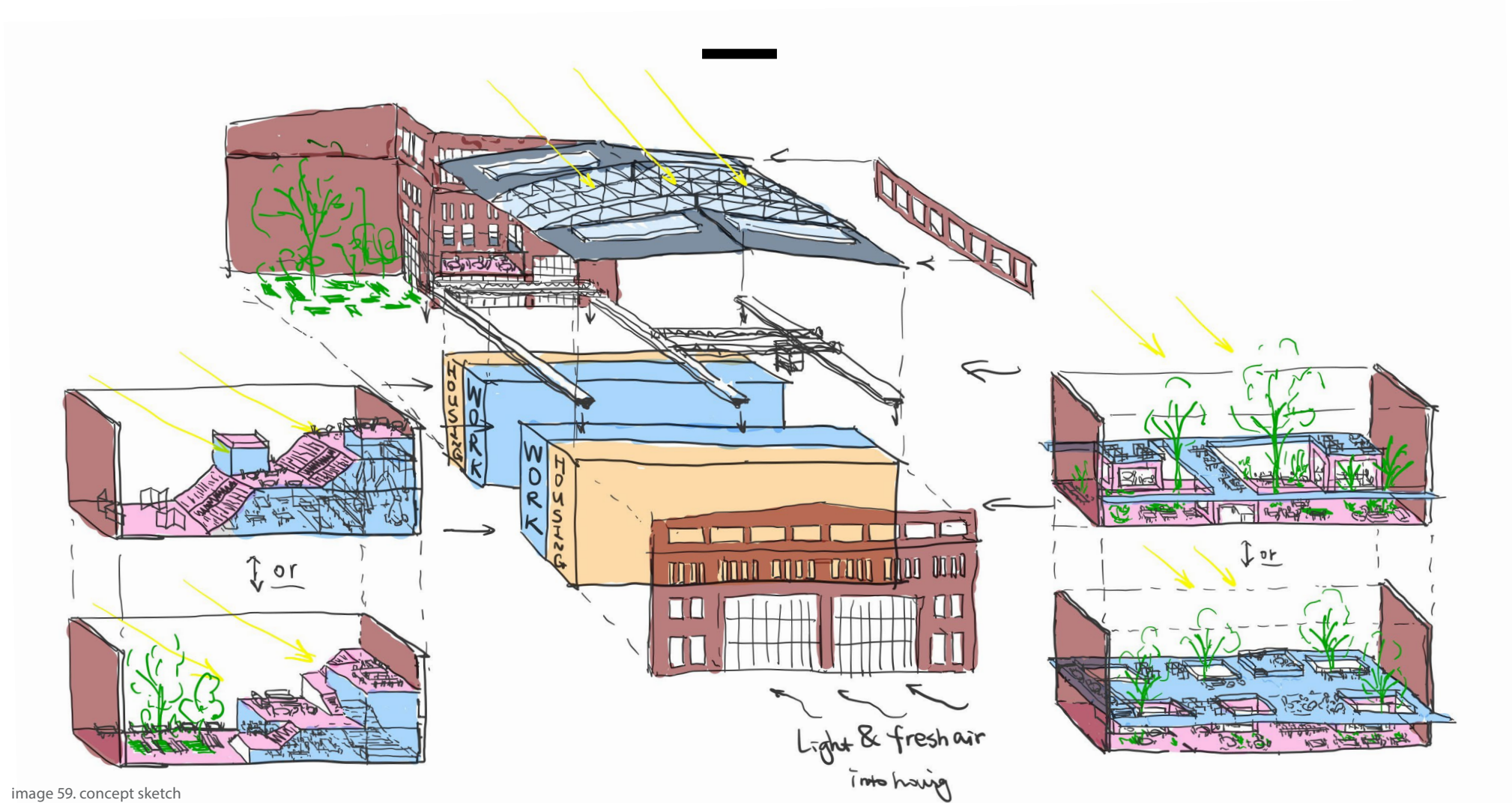
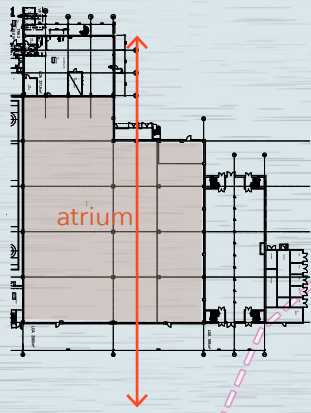
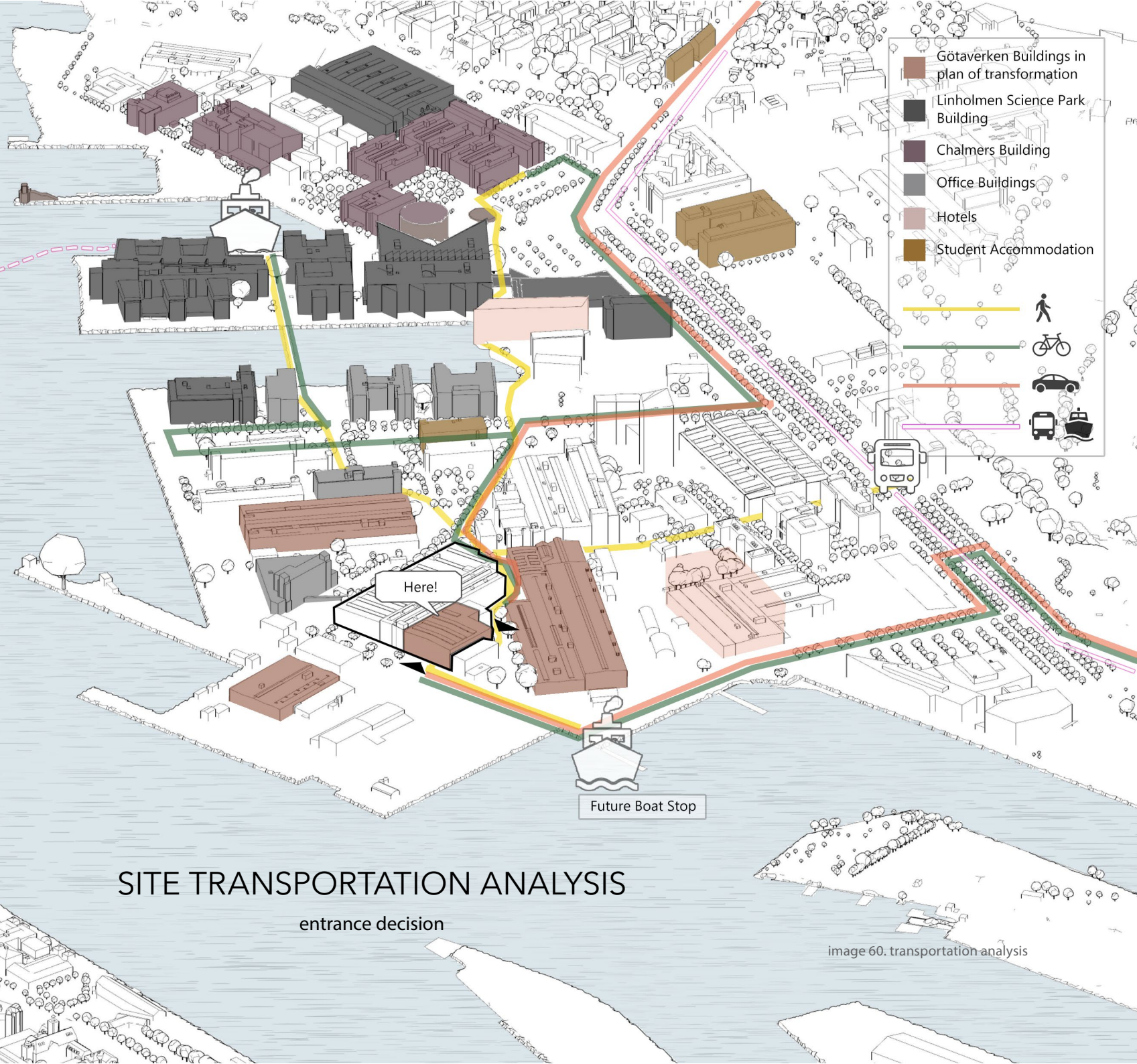

image 59. concept sketch



The transportation analysis shows that there're two main ways to approach Plåtverkstaden and they have similar importance referring to the types of transportation modes. Hence, I decided to have two entrances connected by a big atrium open space, allowing a movement across the ground floor.



- Götaverken Buildings in plan of transformation
 - Linholmen Science Park Building
 - Chalmers Building
 - Office Buildings
 - Hotels
 - Student Accommodation
-
- -
 -
 -

SITE TRANSPORTATION ANALYSIS

entrance decision

ELEVATION TRANSFORMATION

limitation & freedom



- Guidelines

According to Älvstranden, there're some freedom in the transformation of elevation concerning adding openings. For example, to them the gates can be directly replaced by glass facade. It is noted that, the transformation of elevation should be consistent with exiting rhythm of the facade expression when adding more windows on the wall.



Existing elevation

FASAD MOT SYDOST



Proposed elevation

FASAD MOT SYDOST

VERSION 1



FASAD MOT SYDOST

VERSION 2

- Entrance

There are two main entrances to access Plåtverkstaden. One is at the huge symmetrical front gates(southeast facade), for people getting off from the future ferry stop, one is at the back of Plåtverkstaden(northwest), for the people from the Lindholmen Science Park side and from the nearest bus station.

- New windows added

There are four big windows on the front facade(southeast) at the ground floor level for housing units' daylight access. There also many side windows added on three facades(southeast, northwest, northeast) at the top floor level, to introduce more daylight for the big atrium space.

For the side windows added, the height is defined by reserving height for indoor roof insulation and outdoor potential snow cover in the winter.

The new openings will need support by hidden beam above the opening.

- Indoor garden for residents

Near the entrance B is the indoor garden for residents living inside. To allow for fresh air in while retain a level of privacy, a Japanese style wooden gate is used with access control.

Meanwhile, as a prophesy for the visitors, the wooden aesthetic fits with the timber materials used inside Plåtverkstaden.

Existing elevation



Proposed elevation



SPATIAL CONFIGURATION 1

bright housing units and shared public space with gardens

- Housing units with high windows for view and light

Housing units have high windows for light and ventilation. For the units on the southeast facade, tenants have the splendid view towards the river. For tenants live next to the northwest facade, they have the view and natural ventilation from the inner garden whose south wall has many openings without glazing for fresh air.

- Bright atrium with garden

The atrium features a grand skylight above, flooding the whole space with light. The skylight is also important for the huge space to ventilate during hot weather. Plants grow inside the atrium, with cafes and seatings scattering around for people to casually encounter.

People can socialize on the ground floor, and the main beam across the atrium can be transformed into a bridge connecting the top floors of housing units.

- Sight connectivity

People from the roof gardens can overlook at the activities on the ground floor. The atrium allows for sight connectivity to preserve the spacious character of Plåtverkstaden.

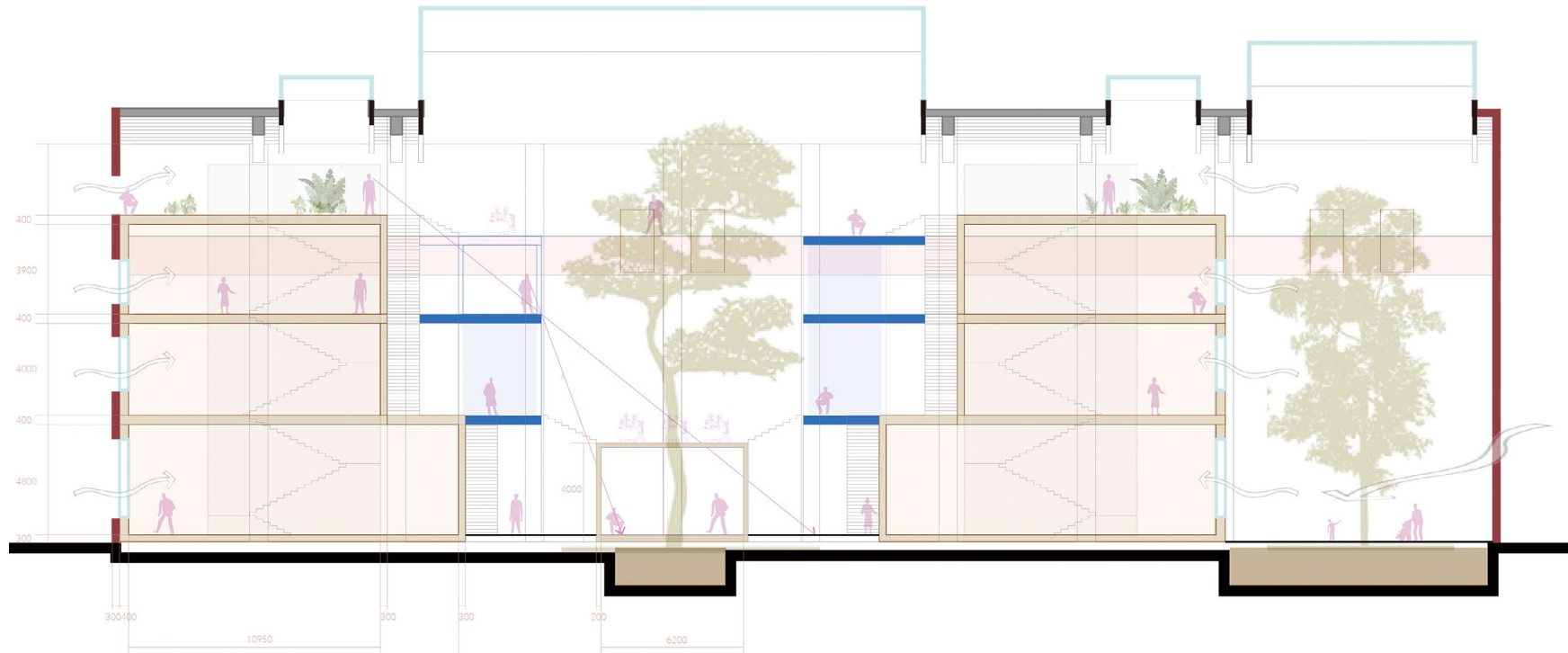

INTERIOR HEIGHT

finding the right dimension

When first entering Plåtverkstaden, I was amazed by the huge volume it has, a 24m span, 48m wide, 17m high giant space, which is whole and unsegmented. The first thought afterwards, is that the new volumes that I put inside shouldn't be too much so the original magnificent scale can still be experienced. The second thought is that, the interior floor heights can be very flexible as there's no limit of existing upper floors.

After the "loft" housing ideas came up to adapt to the existing facade dimensions, how to match workspace floor height with the housing units becomes a challenge for me. The housing units might be higher than 5 meters, which is far too generous for a normal office's need. On the other hand, I hope the working space created here can have a more intimate scale as well as cozy atmosphere than normal offices to make people feel more at home. Additionally, for housing units to have more privacy, it can be a solution to have different floor heights between housing and working functions.

Thus, I need to find the balance between the dimensions of exterior facade, housing units, workspaces, and the circulation to connect them. Meanwhile, it's also interesting for me that people from different ages have different socializing needs. For example, students might want to socialize more than professionals who already have established circles. With smaller scale of offices designed, the 3F of housing and 4F of office can reach the same level, making the 3F residence more public and sociable. Here is a section diagram that also tries to match housing units sizes, the able to afford the rents, and socializing needs.

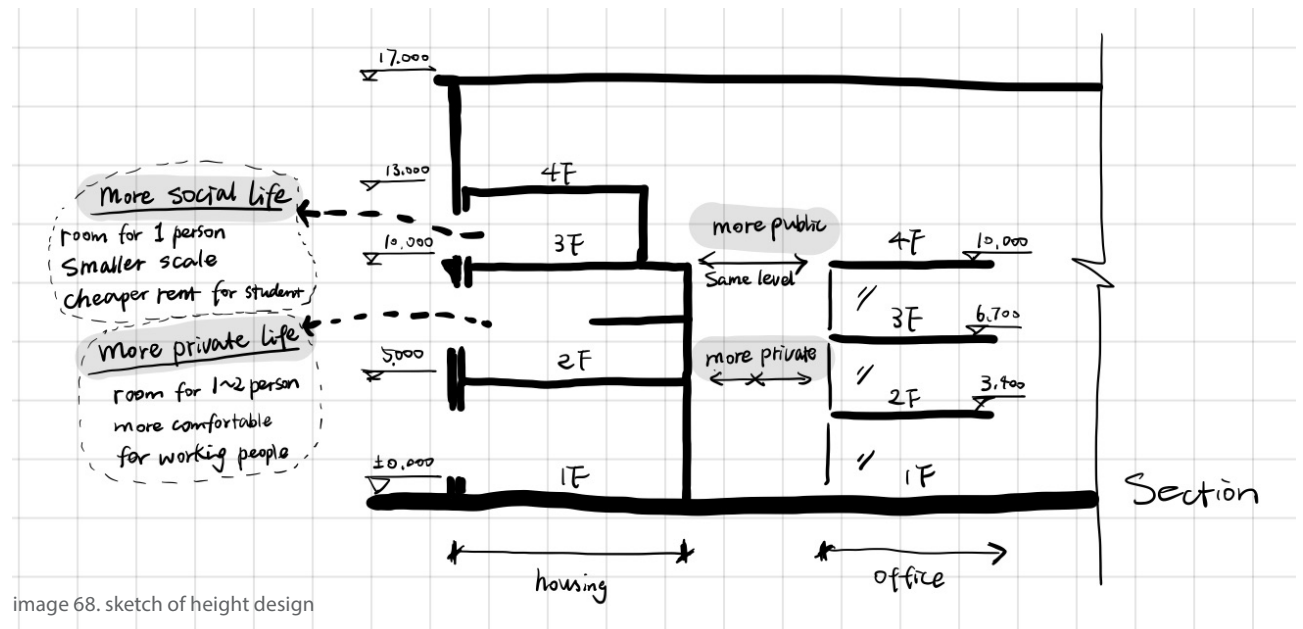

image 68. sketch of height design

SPATIAL CONFIGURATION 2

better daylight and ventilation with social perspectives concerned

- Housing units with natural light and ventilation from two sides

If the working spaces are not adjacent to housing units, but separate from them, then housing can have double-sided daylight and fresh air, which also triggers an interaction between housing unit indoor climate and the atrium indoor climate. For the Loft housing units, the other-sided window is added on the upper floor for more privacy.

- Atrium more generous

With working spaces organized more organically in the middle of the atrium, now the whole space is wider. The scale of Plåtverkstaden can be felt more intuitively.

- Workspaces more flexible

In the spatial configuration 1, working spaces are quite linear as they are sandwiched by housing units and the atrium, for the atrium to have enough room. In the spatial configuration 2, working spaces get more flexible layout as they are not linear anymore. This adapts working spaces better with multiple needs if usage.

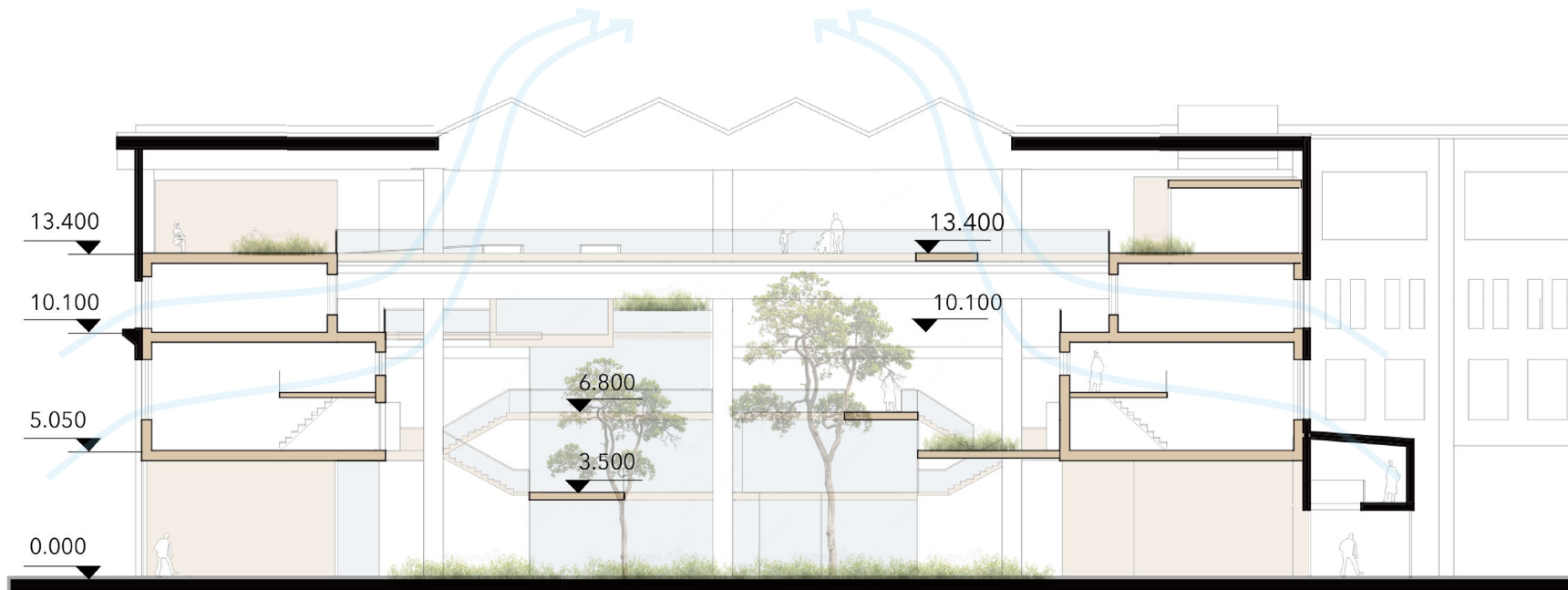

BELONG ANYWHERE & VARIETY OF CHOICES

shared workspace concept development

After studying many innovative working space cases, especially those companies who also want to create a vibrant environment for mobile workers and flexible working hours, I came up with the concept of “belong anywhere with a variety of choices”. This concept was created with the fact that it’s not predictable people of what exactly career types will use the space here, so flexibility and variety become the main goal so that everyone can very likely find a space that suits his/her needs. For example, to accommodate the flexible hybrid working mode after the Pandemic, LinkedIn redesigned its flagship office with more than 75 different types of seating. Airbnb also takes similar strategy by introducing as many types of working space as possible.

Apart from practical considerations, in the social aspect, it seems important to me to design workspaces that make people feel at home instantly. The people living here will be changing more frequently than normal housing, hence the sense of belonging will be crucial for formation of a lively community.

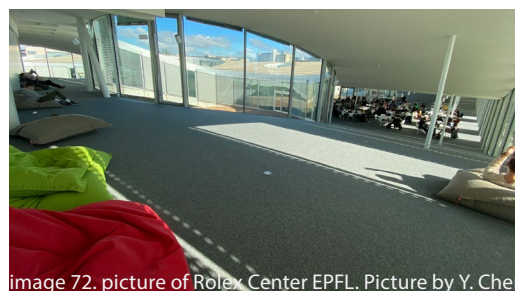
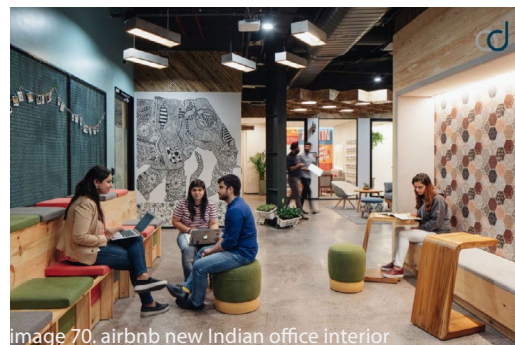
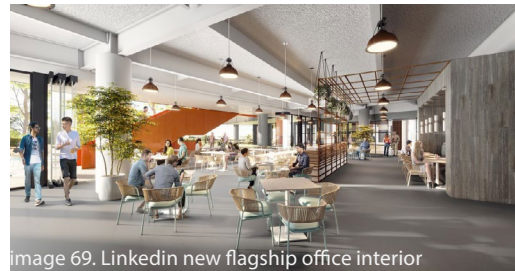

Ideas applied to my design

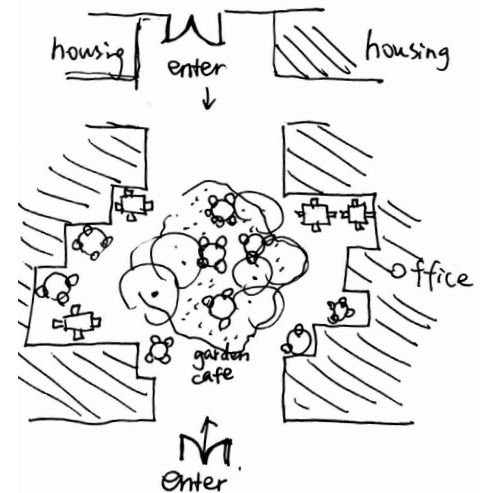
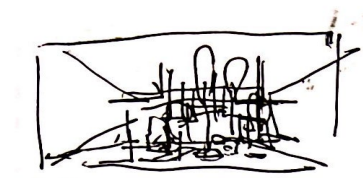
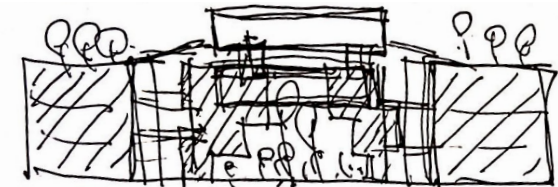

To me, the sense of belonging stems from casualness. This knowledge is derived from my experience in EPFL Switzerland when I was using the Rolex Learning Centre designed by SANAA. In the busy learning centre, I never felt uneasy with being surrounded by many strangers, and I can focus very well while feel well included in the space. After spending one semester there, I found that the secret of this feeling comes from the casualness of the space. The open layout and slopes makes it possible for people to sit or lie everywhere as they wish, and the soft couches and moveable furnitures scattering around can form discussion corner, or sleeping area, or self-relaxation, or many more functions. Hence, I hope in my design, the shared public space also embrace this casualness, by having open plans, abundant casual meeting places for all floors, and seatings as various and flexible as possible.

Another idea to create the sense of belonging, is to put the casual meeting point right at the first scene you see when you enter a building, according to the designer of the new flagship office of LinkedIn.

In my case, this casual meeting point will be combined with garden and sunshine in the atrium and people can directly see it after entering the building. I would also like to create corners and a sense of half-enclosure around the meeting point so the scale gets more intimate and cozy.

ideas for the program variety & inclusiveness ►

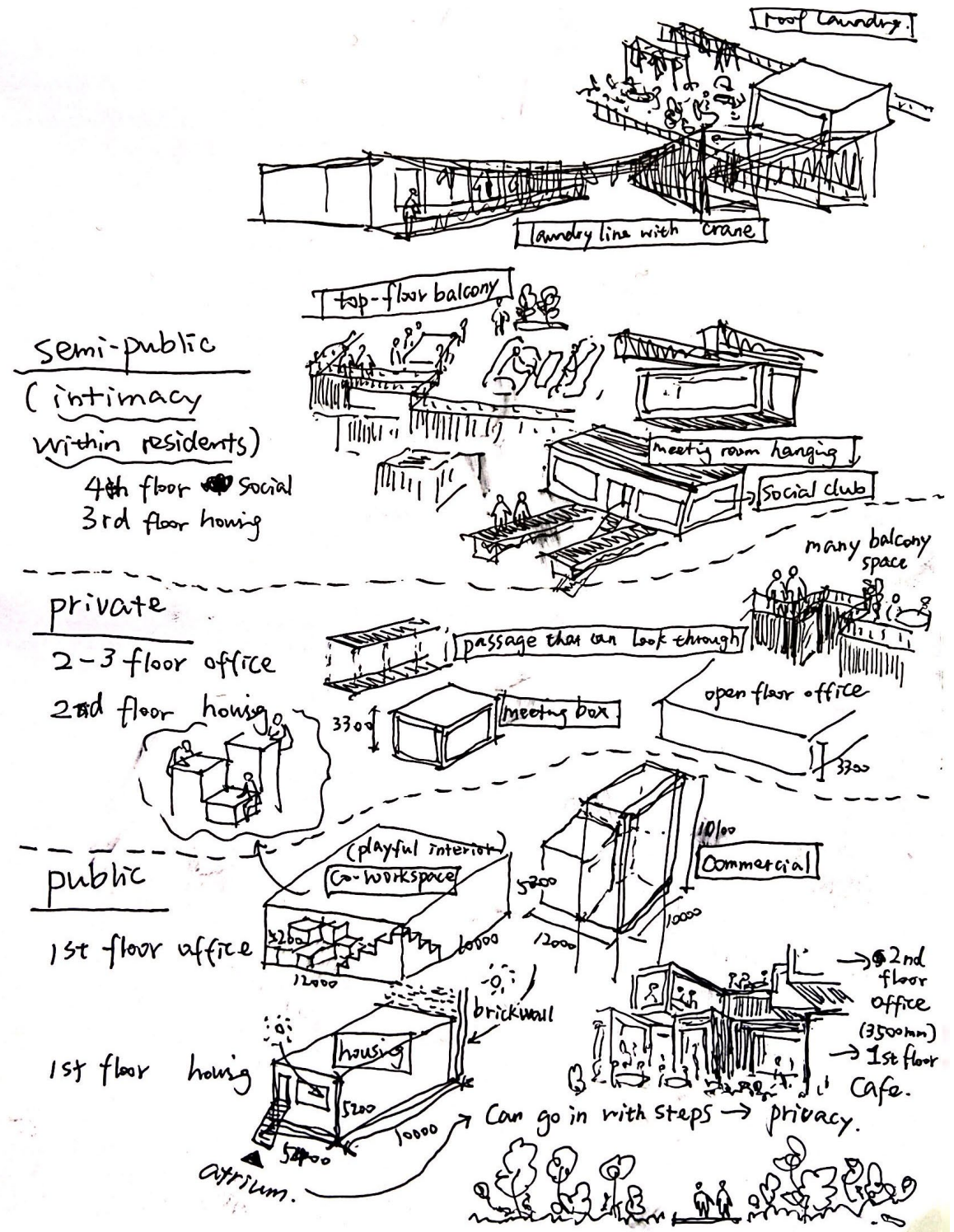

WORKSPACE CASE STUDY

how to create the best workspace for mobile workers?



I concluded two standards of differentiating workspace types, one is according to speed, from which ergonomics can be considered to control how long people are likely to stay in a certain place, another one is according to work needs, for example, situations like stand-up presentation, team meeting, arena, or training course, will need different spatial organizations and characters. I came up with 7 types of workspace prototypes (as shown on the right) from collaborative to individual, from casual to focused, and they will be distributed on different floors.



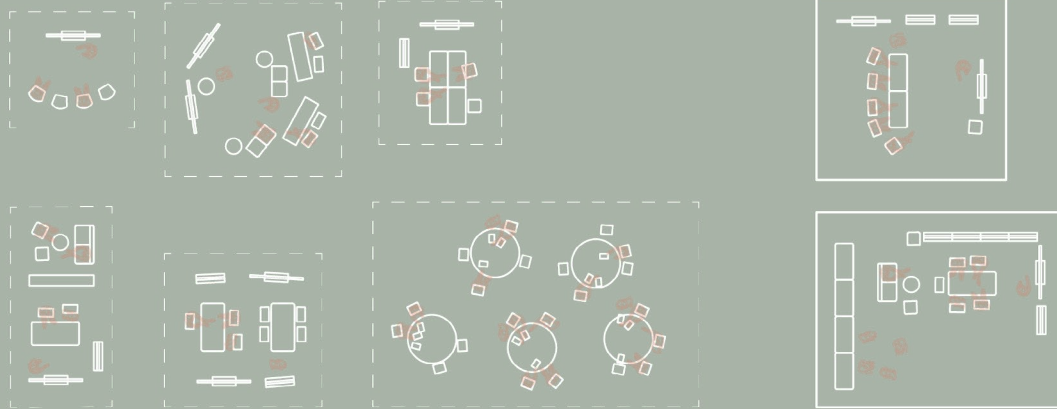
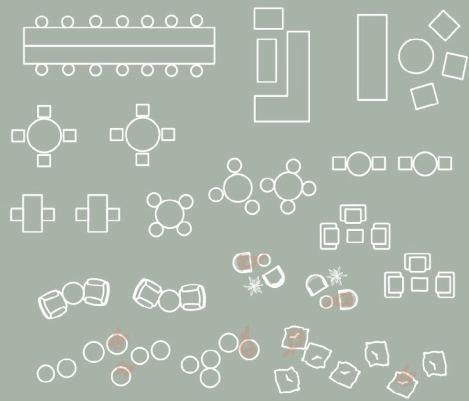

more collaborative social

casual seating /cafe

open plan collaboration zone with moveable furnitures

reservable collaboration room with moveable furnitures

developped plan layouts for a variety of individual and team working possibilities

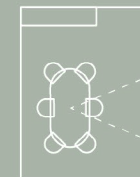
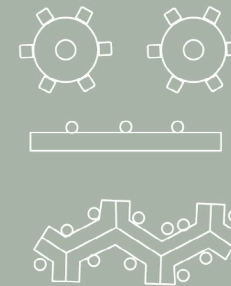
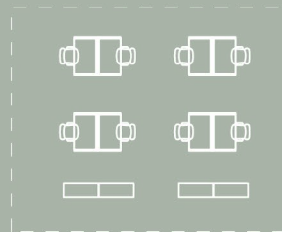

more individual focused ←

private booth

quiet zone

individual working stations

reservable meeting room

image 73. working spaces layout

BRAINSTORMING EXISTING STRUCTURE & ELEMENTS

can old elements carry new missions?

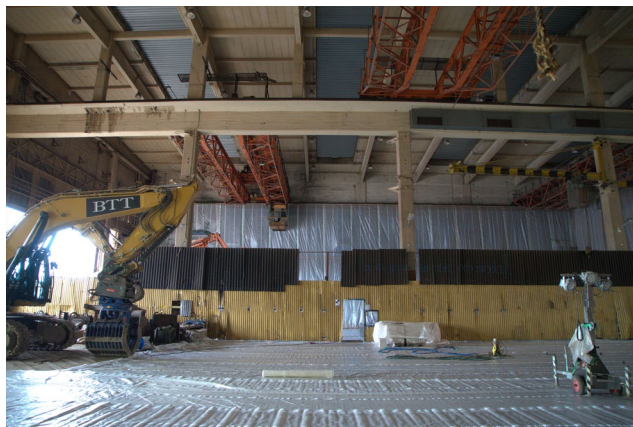
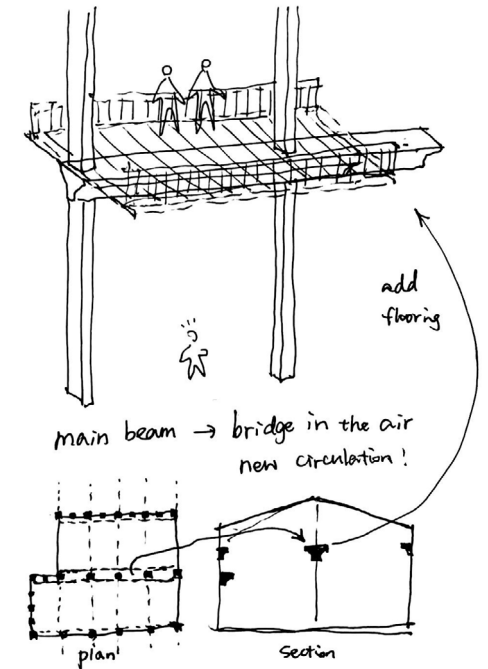
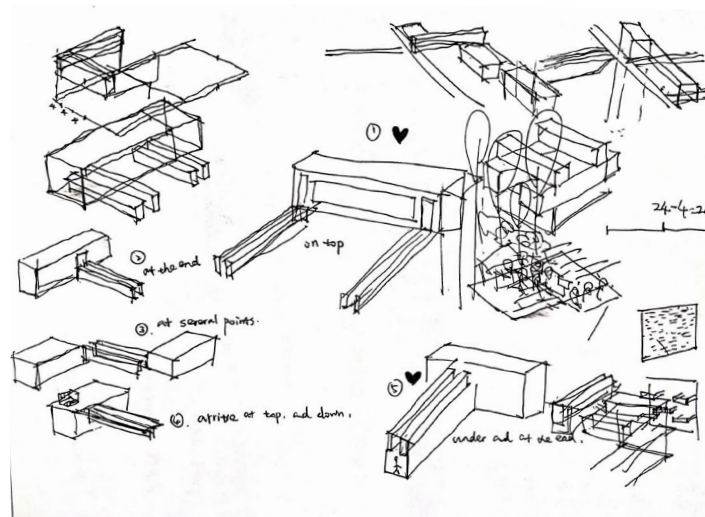

image 74. on-site picture by Y. Chen

There're three sets of double girder overhead cranes inside Plåtverkstaden. They are structurally robust as they hold own enormous weight well. Ideas were developed around how to use those cranes not only for ornaments but also for circulation or even carrying new functions.



The main beam where the cranes sit on runs though the whole building from south to north. If added on flooring on top to expand its width, it can be a potential bridge connecting the housing units, and overlook all the activities underneath.



To introduce in more natural lights, it is important for this transformation project to think about how to open up the roof. Luckily the roof structure are kept well, and the metal sheets can be taken down without much difficulty. Even, if open up totally, the roof structure can potentially be re-used to carry new skylight units.

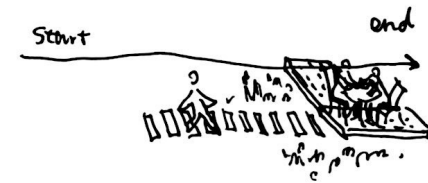
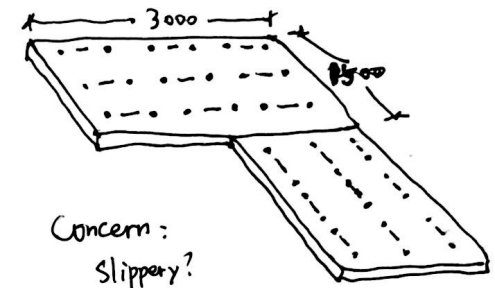
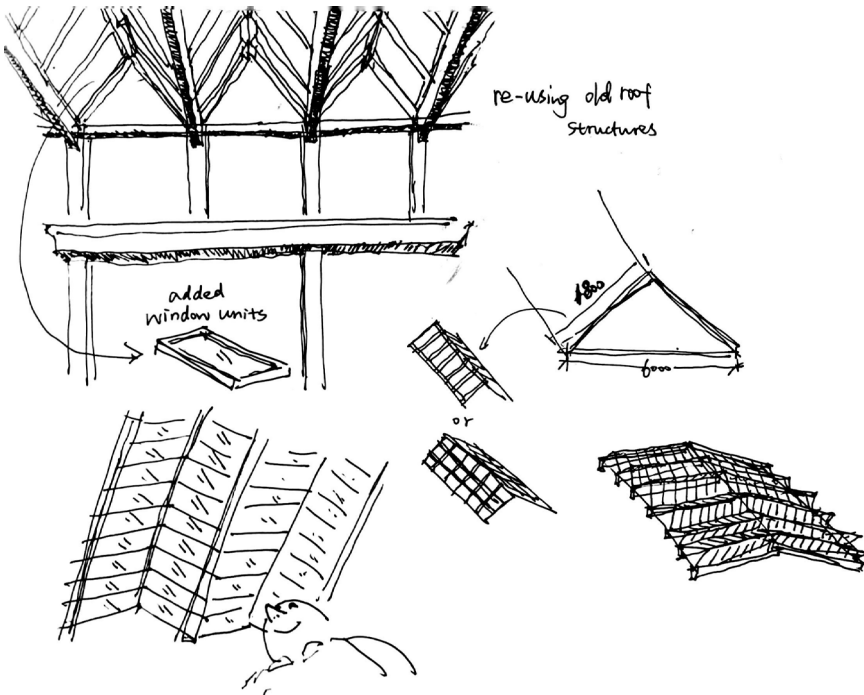

image 75-77. on-site pictures by Y. Chen

The floor slabs inside Plåtverkstaden are unique metal slabs. Though most of them might be moved out, according to the BTT cleaning company, it will be interesting to keep some of them in certain area in the ground floor. For safety consideration, it's better to use the slabs with flat surface instead of the striped ones. Also, in case that they can be slippery for people walking fast, it will be much safer to put them at the end of the circulation where people stop and stay to have a coffee.



OPTIMIZATION FOCUS
DAYLIGHT MEASUREMENTS
TEST PROPOSAL 1
TEST PROPOSAL 2
TEST PROPOSAL 3

4 ●

OPTIMIZATION

OPTIMIZATION FOCUS

which program and what comfort measurement to focus on?



- Focus: Working spaces and shared spaces

Since the existing elevation openings are fixed, and the distribution of housing units are also decided, now the main variation of design lies in the distribution of working and shared spaces in the atrium.

Hence, in this chapter, the simulations focuses on the working spaces and shared spaces from ground floor to the top floor, to see if comfort simulations can be a tool to drive design decisions.

- Focus: Daylight availability

Climate Studio offers a range of analysis types, including site analysis, point-in-time illuminance, daylight availability, annual glare, radiance rendering, thermal analysis, radiation map, and view analysis.

In this chapter, Climate Studio is mainly used for Daylight availability simulations. This is because at this stage of design, daylight is very dependent on the interior spatial configurations, so the simulations can be very useful for making decisions.

- Delimitations

As for the thermal and glare analysis, they can be used in further design phases, which would not be included in this thesis. For example, thermal performance can be improved by rationalizing the hot-water schedule and heating schedules to fit the actual occupancy schedules. Thermal performance can also be improved through construction material and glazing choices, which also depends on the budget and many other considerations.

Point-in-time illuminance analysis is not used in the this chapter. This is because point-in-time illuminance is used for testing the occupied surface for a certain date and time, and this is too detailed for current design stage.

View analysis and Daylight availability analysis for the housing units are also not discussed in this chapter. This is because the existing elevation openings are fixed and there is not much freedom to improve view performance in the design phase.

DAYLIGHT MEASUREMENTS

measurements explanation and my choice

Daylight Factor (DF)

The daylight factor is a measurement of the relationship between the brightness outside and inside on a cloudy day (SGBC, 2014b).

The Daylight Factor (DF) was originally defined as the ratio of the illuminance at a point on a given plane due to the light received directly or indirectly from a sky of known luminance distribution, to the illuminance on a horizontal plane due to an unobstructed hemisphere of this sky, excluding the contribution of direct sunlight to both illuminances (Hopkins, 1963). In ClimateStudio, the DF is evaluated as a unique value, expressing the average of the DFs over an entire plane and for one year.

In the "Results" section of ClimateStudio, the main results one gets for the "Daylight Factor" analysis are the mean and median DF. These values are respectively the mean and median of the DFs of each point in the reference plane, which in turn are the mean of the DFs over one year at these points.

Point-in-time Illuminance (E)

The point-in-time illuminance (E) is the horizontal illuminance on a surface (in this case, the work plane surface) at a point in time. In ClimateStudio, E is evaluated for each virtual sensor in the occupied area at the date and time requested.

Daylight Autonomy (DA)

The Daylight Autonomy (DA) is defined as the percentage of the occupied time when the target illuminance (usually 300lux, DA300) at a point on a reference

plane is met by daylight (Reinhart, 2001). In ClimateStudio, the DA can be retrieved from the spatial Daylight Autonomy (sDA) evaluation, which is defined as the percentage of a reference area that meets the target illuminance (usually 300lux, sDA300/50%) by daylight for a specified fraction of the operating hour per year (usually 50%, sDA300/50%) (IES, 2013).

To evaluate daylight provision according to EN 17037 standard, the "EN 17037" analysis can be made with Climate Studio in the "Daylight Availability" workflow to see how the target and minimum level are reached.

Choice of Measurement

In this chapter, Daylight Factor (DF) is chosen to be the measurement to help making design decisions. This is because DF is a comprehensive whole-year result for the whole selected horizontal surface, instead of focusing on the daylight performance of a particular time or spot on the surface.

Daylight Autonomy (DA) is to set a target level of illuminance and see if it is achieved, so the result is "achieved" or "not achieved", or "fail/minimum/medium/high". For the current design stage, it is not practical to set the respective goals for all different programs and test them altogether, since the result will be too complicated for decision making. Hence, Daylight Autonomy is used in the "Proposal" chapter as a design result to shown a selected room of certain program's performance.

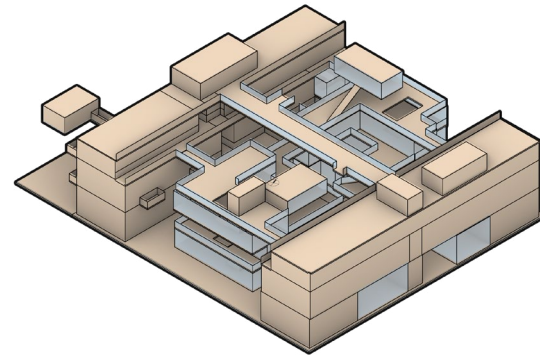
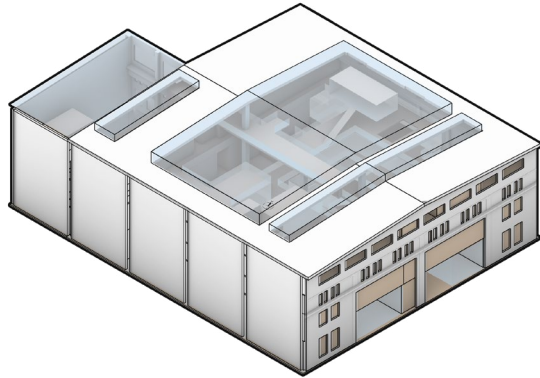

The first proposal has relatively dense working spaces in the atrium. There are three floors of glazed working spaces and the fourth and fifth floor being open balconies.

The result shows that the fourth and fifth floor have abundant daylight. The main problem is the working area in the first three floors have very poor daylight source. The darkest areas in the visualizations are housing units and the staircase cores.

TEST PROPOSAL 1

dense working space & one main skylight for atrium

T.vis is an luminous parameter of the visible transmittance. Here for the cranes, an T.vis value is set to simulate the light that they are blocking. In the following test, other T.vis values are also given to certain objects for simulation.

Layer	Objects	Material	R.vis	T.vis
elevation	781	Red Brick Exterior wall	13.8%	0.0%
surrounding	52	Red Brick Exterior wall	13.8%	0.0%
column, beam	398	Rough Concrete Wall	29.8%	0.0%
timber	910	Cubicle Partition Laminated Wood	48.3%	0.0%
glass	240	Atlantica - Clear (Krypton)	10.2%	58.6%
模拟:桁架 (simulating: crane)	72	Atlantica - Solarban 90 (3)	12.5%	38.1%
roof	82	White Acoustic Ceiling Panels	87.2%	0.0%
roof::glass	54	Solarban 67 (2) - Clear (Krypton)	18.9%	53.0%

4.3% mean DF 1.9% median DF

ID	Description	Type	Tags	Sq. m	Avg. DF	Min. DF	Median. DF	Uniformity
1st floor		Occupie		2377.1	4.27%	0.00%	2.39%	0.00
club		Occupie		42.5	8.34%	4.27%	7.20%	0.51
meeting hanging		Occupie		45.1	2.93%	0.45%	1.91%	0.15
office 2nd		Occupie		6.9	10.32%	6.33%	10.93%	0.61
office 2nd		Occupie		622.1	2.82%	0.05%	0.91%	0.02
office 3th		Occupie		44.8	14.47%	3.17%	14.89%	0.22
office 3th		Occupie		164.3	1.48%	0.48%	1.04%	0.32
office 3th		Occupie		75.0	11.94%	1.94%	10.84%	0.16
office 3th		Occupie		296.2	5.69%	0.13%	1.86%	0.02
Total				3674.0	4.34%	0.00%	1.94%	0.03

test of 1-3F

ID	Description	Type	Tags	Sq. m	Avg. DF	Min. DF	Median. DF	Uniformity
balcony 4F		Occupie		153.1	31.74%	11.51%	32.36%	0.36
balcony 4F		Occupie		226.2	16.49%	3.41%	12.21%	0.21
balcony 4F		Occupie		171.9	13.11%	1.77%	10.44%	0.14
balcony 4F		Occupie		126.5	13.53%	4.35%	14.80%	0.32
balcony 5F		Occupie		904.4	13.94%	1.59%	9.59%	0.11
Total				1582.1	15.90%	1.59%	11.76%	0.17

test of 4-5F

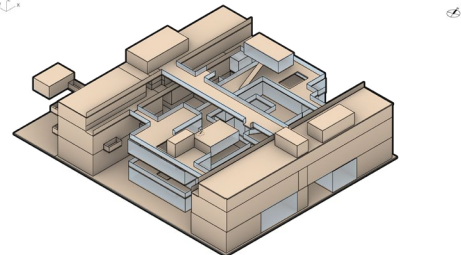
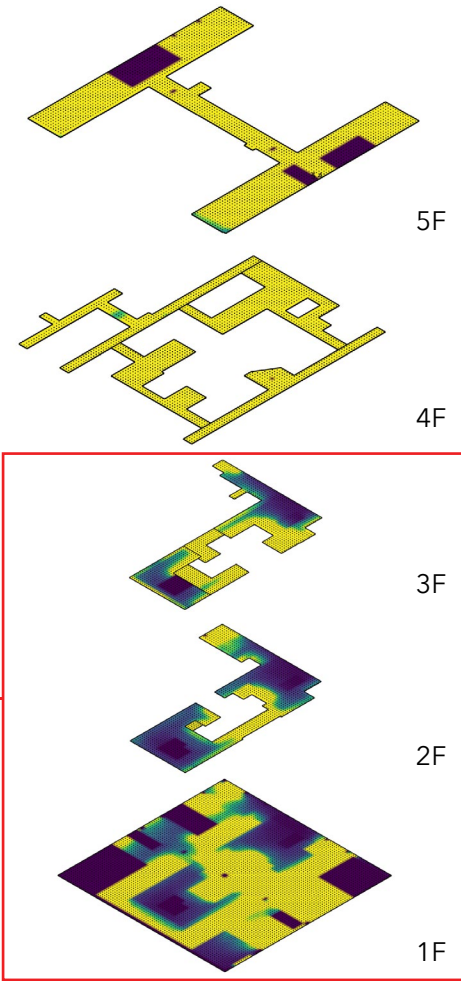

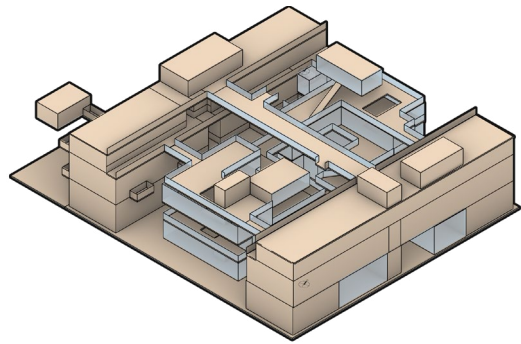
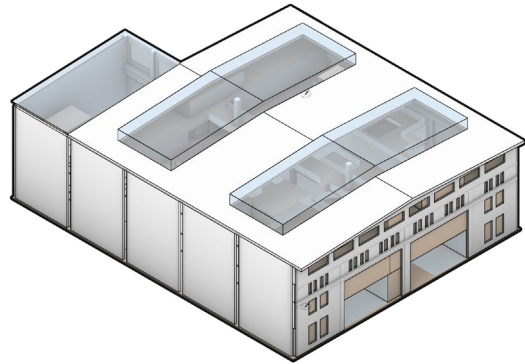

TEST PROPOSAL 2

dense working space & two separate skylights for atrium

staircase is not obvious, it might be the reason that the skylights' location is changed. For further studies, it could be considered to have a skylight on the roof right above the staircase cores.

Layer	Objects	Material	R.vis	T.vis
elevation	781	Red Brick Exterior wall	13.8%	0.0%
surrounding	52	Red Brick Exterior wall	13.8%	0.0%
column, beam	398	Rough Concrete Wall	29.8%	0.0%
桁架 (crane)	3168	Aluminum metal cladding	64.8%	0.0%
timber	894	Cubicle Partition Laminated Wood	48.3%	0.0%
glass	234	Atlantica	6.4%	66.3%
模拟::桁架 (simulating: crane)	72	Atlantica - Clear (Argon)	10.2%	58.6%
模拟::elevator (simulating: ...)	4	Atlantica - Clear (Argon)	10.2%	58.6%
roof:glass	90	White Acoustic Ceiling Panels	87.2%	0.0%
roof:glass	71	Solarban 67 (2) - Clear (Krypton)	18.9%	53.0%
timber::木条 (...: timber strips)	194	Unpainted Wooden Door	52.6%	0.0%
模拟::staircase (simulating:...)	38	Azuria - Solarban 90 (3) (Argon)	13.0%	38.8%

4.3%	2.5%
mean DF	median DF

ID	Description	Type	Tags	Sq.m	Avg. DF	Min. DF	Median. DF	Uniformity
1st floor	Occupie	Occupie		2377.1	4.20%	0.00%	2.26%	0.00
club	Occupie	Occupie		42.5	3.17%	1.96%	2.69%	0.62
inner garden	Occupie	Occupie		273.9	10.29%	4.02%	10.18%	0.39
seeting hanging	Occupie	Occupie		45.1	3.67%	1.87%	2.85%	0.51
office 2nd	Occupie	Occupie		622.1	2.29%	0.02%	0.97%	0.01
balcony	Occupie	Occupie		6.9	1.33%	0.93%	1.38%	0.70
office 3th	Occupie	Occupie		296.2	4.08%	0.22%	2.33%	0.05
office 3th	Occupie	Occupie		164.3	1.87%	0.21%	1.20%	0.11
office 3th	Occupie	Occupie		44.8	7.96%	2.97%	7.87%	0.37
office 3th	Occupie	Occupie		75.0	5.70%	1.82%	5.27%	0.32
Total				3947.9	4.26%	0.00%	2.47%	0.06
balcony 4F	Occupie	Occupie		153.1	19.51%	2.62%	19.40%	0.13
balcony 4F	Occupie	Occupie		226.2	13.17%	1.94%	10.45%	0.15
balcony 4F	Occupie	Occupie		171.9	23.60%	1.64%	26.03%	0.07
balcony 4F	Occupie	Occupie		126.5	21.68%	4.95%	23.49%	0.23
balcony 5F	Occupie	Occupie		904.4	17.32%	2.05%	15.05%	0.12
Total				1582.1	17.98%	1.64%	16.10%	0.13

With an attempt to improve the glazed working space daylight performance, a gesture of changing the location of skylights is made. The mean DF stays the same while median DF gets higher.

The second proposal has two skylight, locating above the spaces between the working and housing program, intending to give working spaces more light from both sides.

On the other hand, the staircases are simulated as they are transparent with glass walls, to see if it can introduce more light through the working floors. However, the effect of the

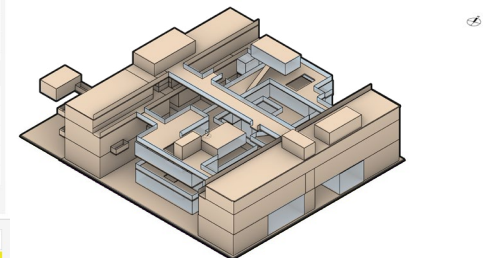
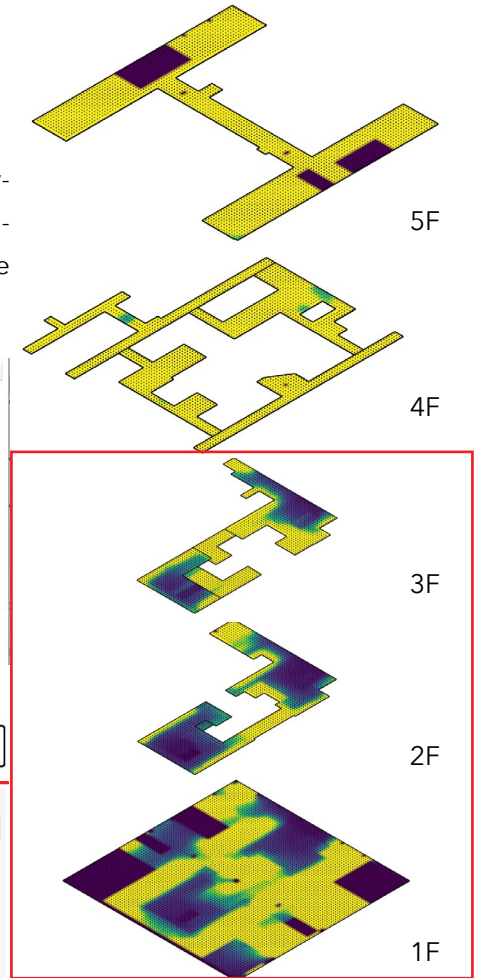

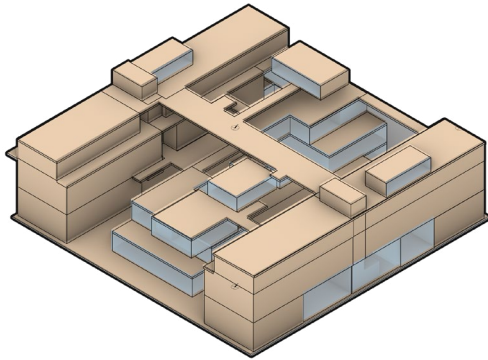
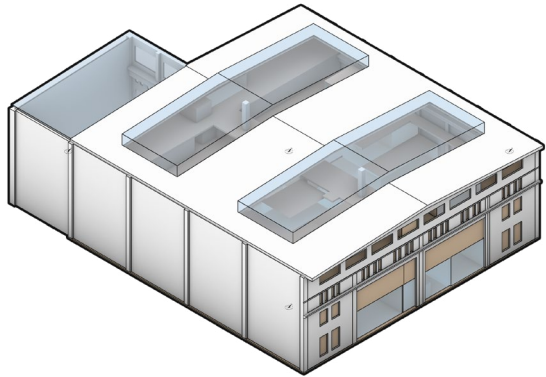

TEST PROPOSAL 3

more open working spaces & two skylights for atrium

For further improvements on the DF result, boxes with special program can be made more transparent, skylight above the staircase cores can be considered. The facade material of timber units can have lighter color or higher visible reflectance value.

The 3rd proposal has the same skylight as the 2nd proposal - two separate skylights, and it also decreases the floor area of working spaces, and decreases the glazed area especially. According to the daylight result 5.15% mean DF and 2.98% median DF, reduction of program is useful for getting more daylight.

Other changes made in this proposal include increasing open area on the ground floor, increasing open balconies, simplifying the circulation and reducing the staircase cores' storeys.

Layer	Objects	Material	R.vis	T.vis
surrounding	78	Red Brick Exterior wall	13.8%	0.0%
elevation	2340	Red Brick Exterior wall	13.8%	0.0%
column, beam	796	Rough Concrete Wall	29.8%	0.0%
桁架 (crane)	3168	Aluminum metal cladding	64.8%	0.0%
timber	2204	Cubicle Partition Laminated Wood	48.3%	0.0%
timber::木条 (... timber strips)	388	Unpainted Wooden Door	52.6%	0.0%
glass	546	Atlantica	6.4%	66.3%
模拟::桁架 (simulating: crane)	216	Atlantica - Clear (Argon)	10.2%	58.6%
模拟::elevator (simulating: ...)	12	Atlantica - Clear (Argon)	10.2%	58.6%
模拟::new staircase (simulating: ...)	2	Atlantica - Clear (Krypton)	10.2%	58.6%
roof	196	White Acoustic Ceiling Panels	87.2%	0.0%
roof::glass	176	Solarban 67 (2) - Clear (Krypton)	18.9%	53.0%

ID	Description	Type	Tags	Sq. m	Avg. DF	Min. DF	Median. DF	Uniformity
NEW 1F	Occupie	Occupie		2377.1	4.59%	0.00%	2.41%	0.00
NEW 2F	Occupie	Occupie		71.5	2.39%	0.41%	2.34%	0.17
NEW 2F	Occupie	Occupie		110.9	13.27%	5.01%	14.08%	0.38
NEW 2F	Occupie	Occupie		213.1	3.92%	0.25%	1.95%	0.06
NEW 2F	Occupie	Occupie		225.7	3.31%	0.39%	2.09%	0.12
NEW 3F	Occupie	Occupie		53.3	5.44%	0.58%	6.00%	0.16
NEW 3F	Occupie	Occupie		214.9	4.63%	0.71%	3.18%	0.15
NEW 3F	Occupie	Occupie		34.4	3.44%	2.32%	3.12%	0.67
NEW 3F	Occupie	Occupie		68.9	12.55%	2.12%	12.56%	0.17
NEW 3F	Occupie	Occupie		16.2	10.96%	5.79%	10.08%	0.53
NEW 3F	Occupie	Occupie		152.5	10.82%	1.12%	10.05%	0.10
NEW 4F	Occupie	Occupie		184.8	7.40%	2.15%	5.98%	0.29
NEW 4F	Occupie	Occupie		48.5	3.05%	1.27%	2.53%	0.42
NEW 4F	Occupie	Occupie		167.9	8.07%	2.10%	5.96%	0.24
NEW 4F	Occupie	Occupie		95.6	15.08%	5.13%	10.93%	0.34
NEW 5F	Occupie	Occupie		56.7	2.45%	1.16%	1.83%	0.47
NEW 5F	Occupie	Occupie		900.7	20.49%	1.90%	17.32%	0.09
Selected				3538.4	5.15%	0.00%	2.98%	0.06

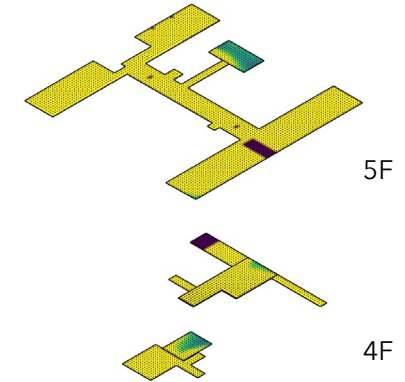

5F

4F

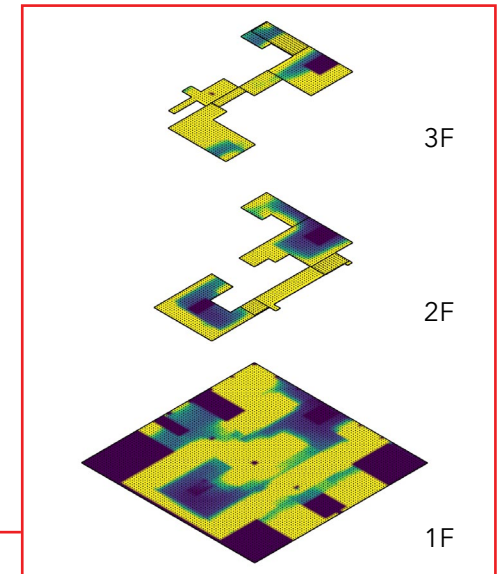

3F

2F

1F

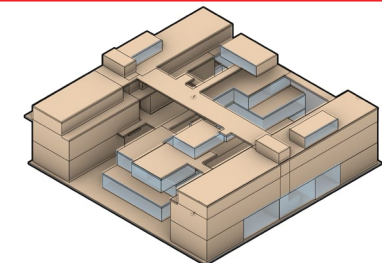

A closer look at the 3 proposals' first three floors daylight performance.

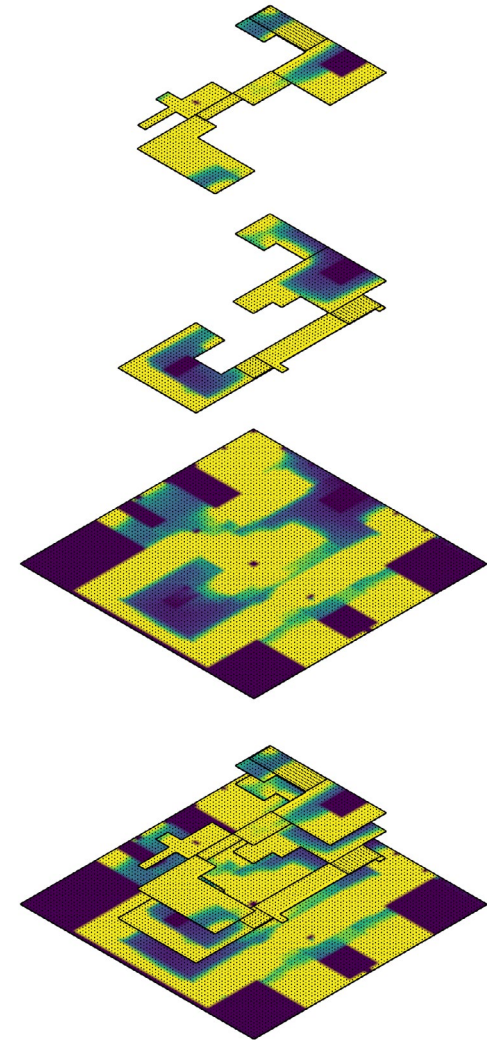
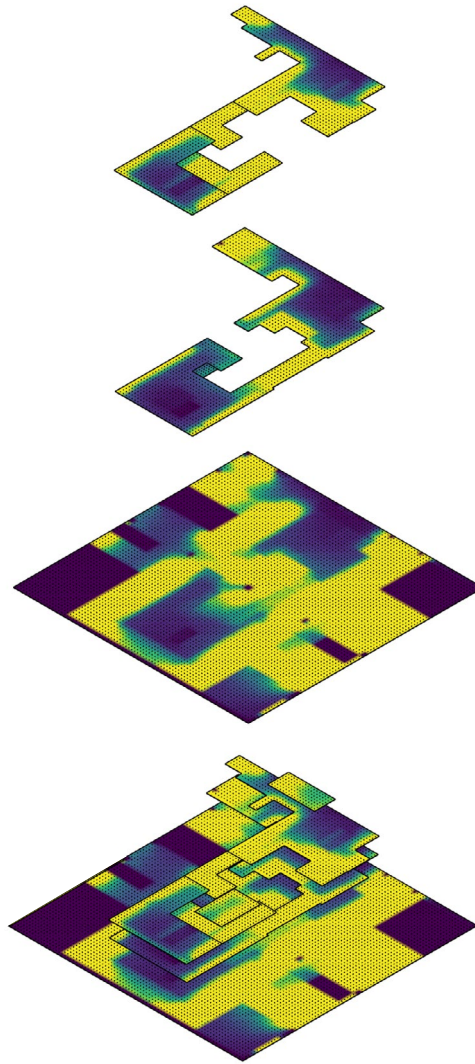
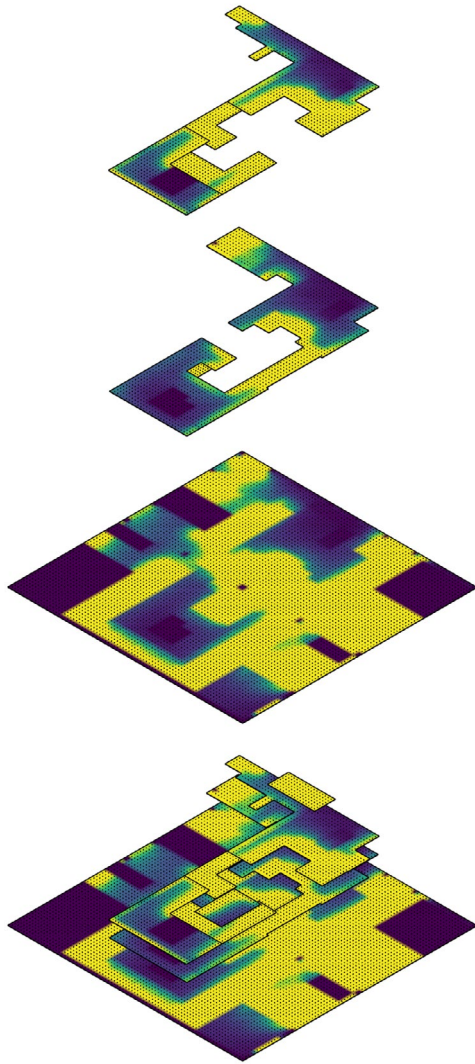

3F

2F

1F

1+2+3F



Proposal 1

Proposal 2

Proposal 3

5.

SELECTION OF TIMBER SYSTEMS
CONSTRUCTION STRATEGY
ATRIUM ACOUSTIC STRATEGY

TIMBER

SELECTION OF TIMBER SYSTEMS

for working and shared spaces, housing units



Office and Shared spaces - To Beam or Not to Beam? to Beam or Two Beam?

As discoursed in the “height” part from the “Design” chapter, the floor height of working spaces is around 3.4 meters (excluding 300mm floor structure thickness). Within this dimension, the working spaces are aimed to create an intimate and home-like atmosphere so that tenants feel comfortable to connect with each other.

For the flexibility of layout and transparency, post system instead of bearing wall system is considered. On the right displays three types of post systems with CLT.

The CLT point supported system is the first excluded one, as the distance of each post is limited by the dimension of plate that can be manufactured and transported. For reference, among point supported CLT completed projects in North America, the biggest spacing between post grid is around 2.7-meter times 4-meter. With this density of posts, the working spaces would be too hard to use.

Out of the considerations are the price and whether it is fast to assemble, one-way beams system is chosen for the working spaces, as it reduces beam structure while the thickness of CLT slabs stay the same. It also brings clarity due to fewer structure elements and more generous interior space.

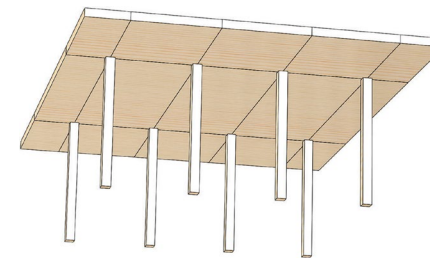

image 78. Point Supported CLT

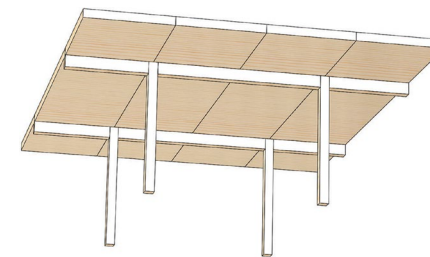

image 79. One-Way Beams

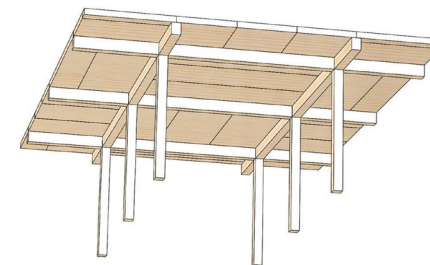
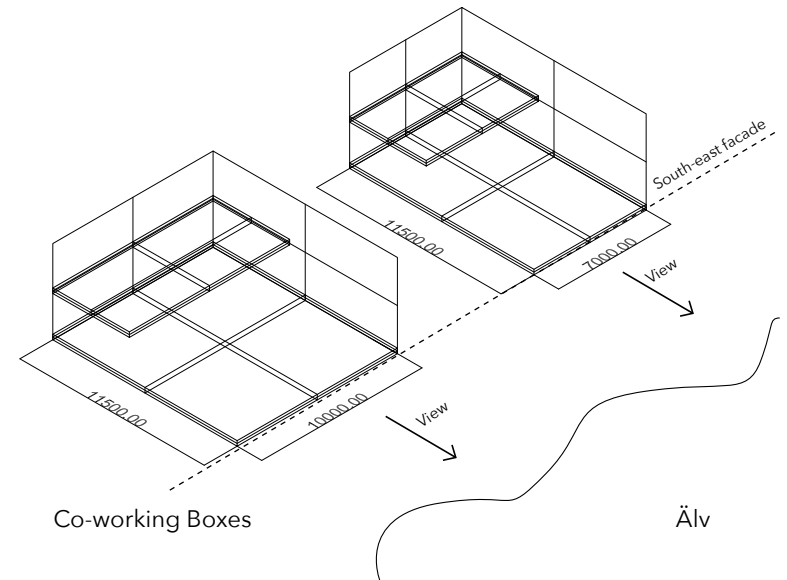

image 80. Two-Way Beams

Co-working Boxes next to the Exterior facade

In current design, there are two boxes of co-working program at the southeast elevation next to the entrance. They have more than 5-meter height, same as the 1st floor housing units next to them. To utilize the height better, self-supported mezzanine spaces are introduced to occupy half of the upper level. The ground floor aims to have a generous open space with a view out the giant glass facade facing the Älv river, hence it would be better if no posts are in the middle of the view.

The spans of the boxes are 7-meter and 10-meter respectively, with a depth of 11.5-meter. For them the two-way beam system is not applicable for the dimension is not squared. Instead, one-way beam system is selected while there is also surplus height for large beams to cross 7 or 10 meters.



Housing units - CLT with bearing walls

The housing units have spans ranging from around 3 meters to around 5 meters.

Due to privacy consideration and the regular layout determined by the exterior wall, there are no need for spatial transparency and flexibility by using CLT post and beam system.

For CLT point supported system, the biggest span is around 4 meters due to limitation of plate pre-fabrication and the safety concerns of transportation, which is not enough for the housing units dimensions in this project.

Hence, the system selected for housing units is "CLT with bearing walls".



image 81. Bearing Walls construction

CONSTRUCTION STRATEGIES

for the cold zone

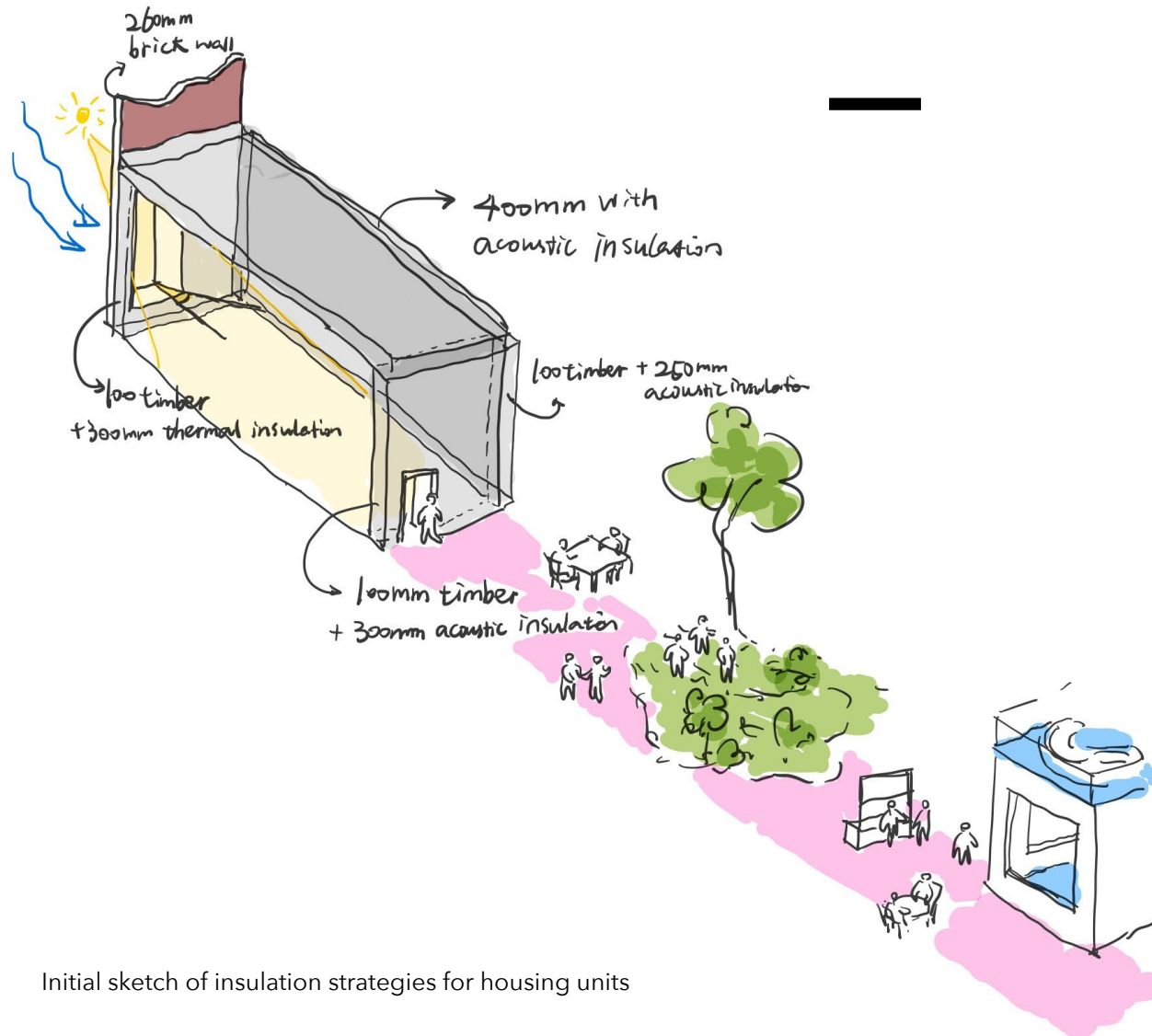

Initial sketch of insulation strategies for housing units

- Dimensions

From the thermal perspective, inside Plåtverkstaden it can be considered as two zones, that is the cold zone and warm zone. Cold zone is the interface between housing units and the exterior brick wall. And all the other area without direct access to exterior air belongs to the warm zone.

Thermal performance is the ultimate goal for walls in the cold zone, whereas acoustic performance is the main goal for walls in the warm zone.

To make sure residents have thermal comfort during the cold seasons, the wall against exterior facade is given a dimension of around 400mm thickness to have enough thermal insulation.

For acoustic considerations, the floor structure of housing units is given 400mm thickness for space for impact sound insulation to reduce footstep sound from people walking on top, while the wall structure between housing units and the atrium is given also 400mm thickness for enough airborne insulation.

- CLT construction Reference for Comfort

Wall reference for Exterior wall of housing units :

*total thickness 409mm,
U-value [W/m2K] 0.15,
fire class REI60.*

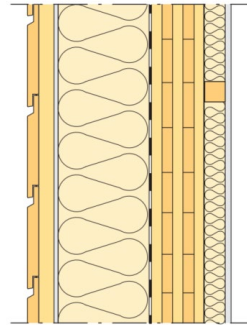

- 22 external cladding
- 34 battens
- Wind protection
- Vapour retarder
- 195 heavy insulation
- 100 CLT panel
- 45 studs and insulation
- 13 plasterboard

Wall reference for Partition wall between apartments using load-bearing CLT panel:

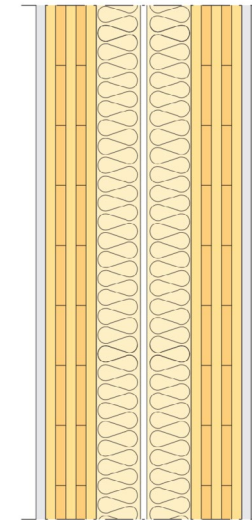

- 13-15 plasterboard
- 100 CLT panel
- 70 insulation
- 10 air gap
- 70 insulation
- 100 CLT panel
- 13-15 plasterboard

Floor reference for Exterior wall in connection with floor system

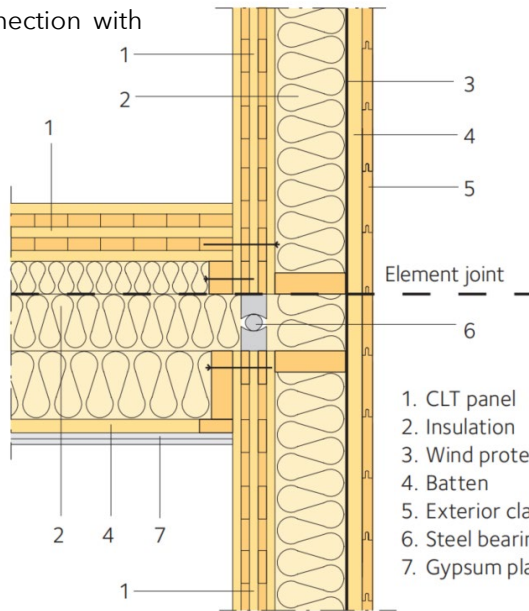

Element joint

- 1. CLT panel
- 2. Insulation
- 3. Wind protection
- 4. Batten
- 5. Exterior cladding
- 6. Steel bearing to reduce flanking transmission
- 7. Gypsum plasterboard

Wall reference for Exterior wall window mounting :

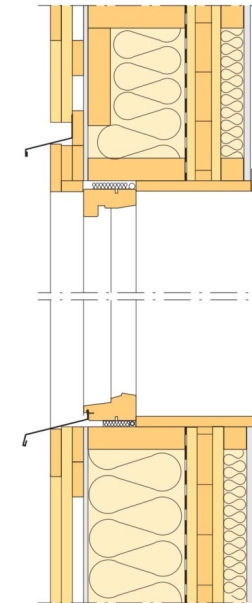

image 82-85. construction details from The CLT Handbook CLT structures -facts and planning

ATRIUM

ACOUSTIC STRATEGY

ceiling, flooring and facade

- Flooring

The flooring of atrium needs to be durable, visually attractive, and to have good acoustic property too. "Kubb" can actually satisfy all three of those aspects. Kubb is a way to make solid wood floor that is laid with the end wood upwards and glued to the substrate. As the floor can be very thick then the wood pieces are longer, it becomes extremely durable since it is easy to clean or sand. The thickness also brings good acoustic properties. Base is made in pine, spruce, larch, smoked larch, oak and smoked oak.

- Facade & Ceiling

Wood-slatted ceilings or timber-clad walls can be made with those linear rib timber panels. The veneer is made of real wood. The core is fiber gypsum board which has excellent properties regarding both fire safety and acoustics, and is sustainable to use as the emissions of results are extremely low with a high rate of recycled content.

The linear system of this type of facade gives a relatively large open area of 24% which guarantees a good sound absorption over a wide band of frequencies, according to the supplier. The three-dimensional shape also contributes to sound diffuser.

It can be assembled very quickly with the concealed aluminum profile installation system. There is also available demountable version, which is ideal for places that need access to ancillary systems.

image 86-88. kubb flooring examples

image 89. linear rib timber panel application example



6.

ELEVATIONS
PLANS & SECTIONS
HOUSING PLANS & SECTIONS
VISUALIZATIONS
REFLECTION

PROPOSAL

VIEW FROM THE RIVER

exterior rendering



ELEVATIONS

south-east



before



after

ELEVATIONS

north-east



before



after

ELEVATIONS

north-west



before



after

PLANS

ground floor

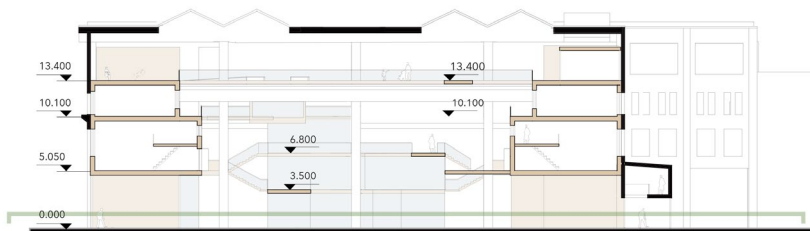
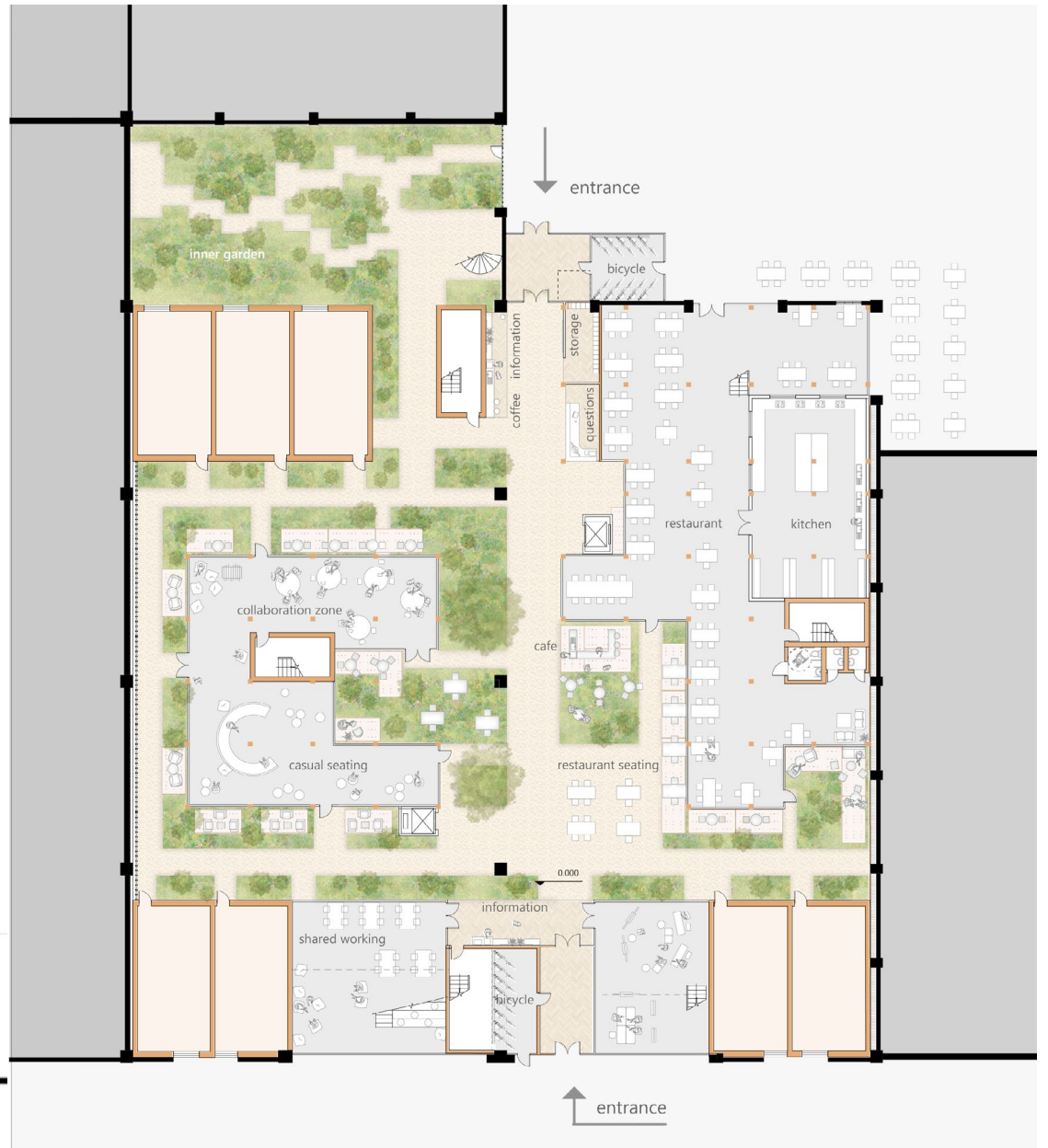

PLANS

housing 1st floor, office 2nd floor

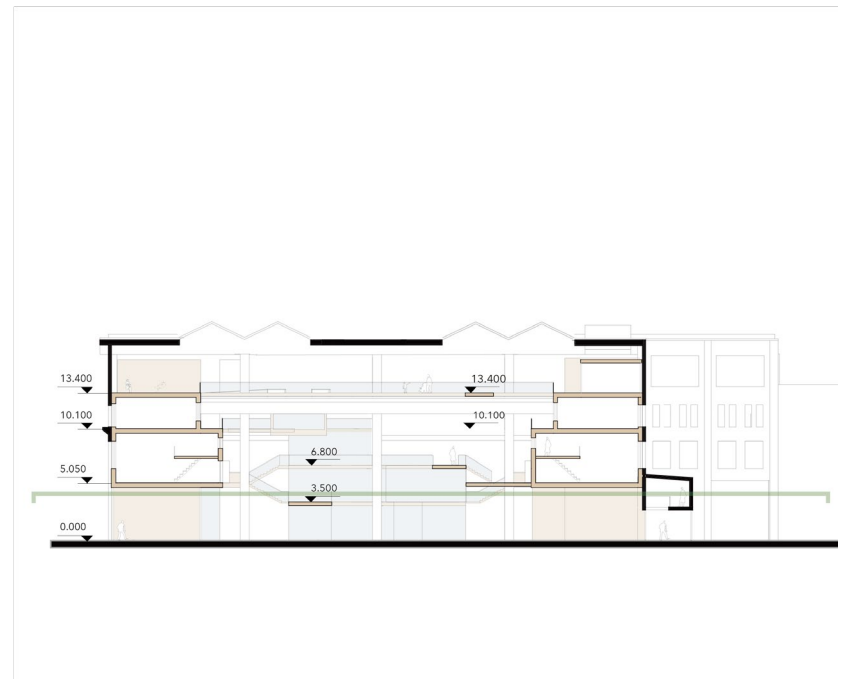
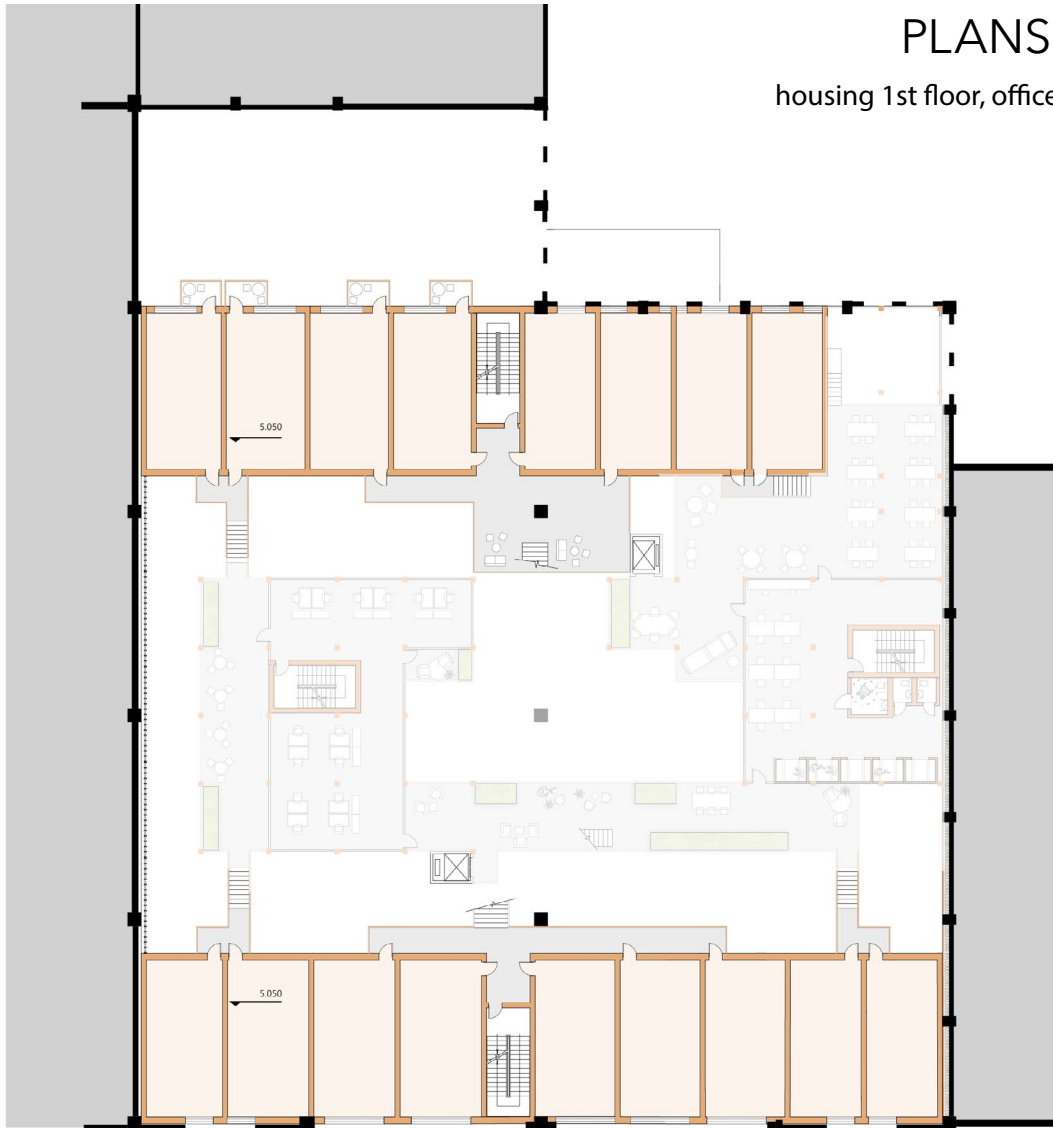

PLANS

housing 2nd floor, office 2nd floor

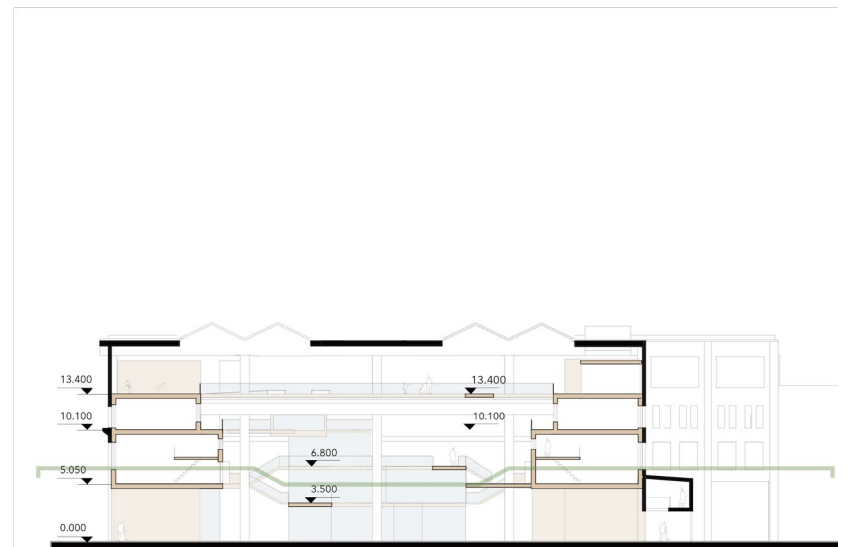
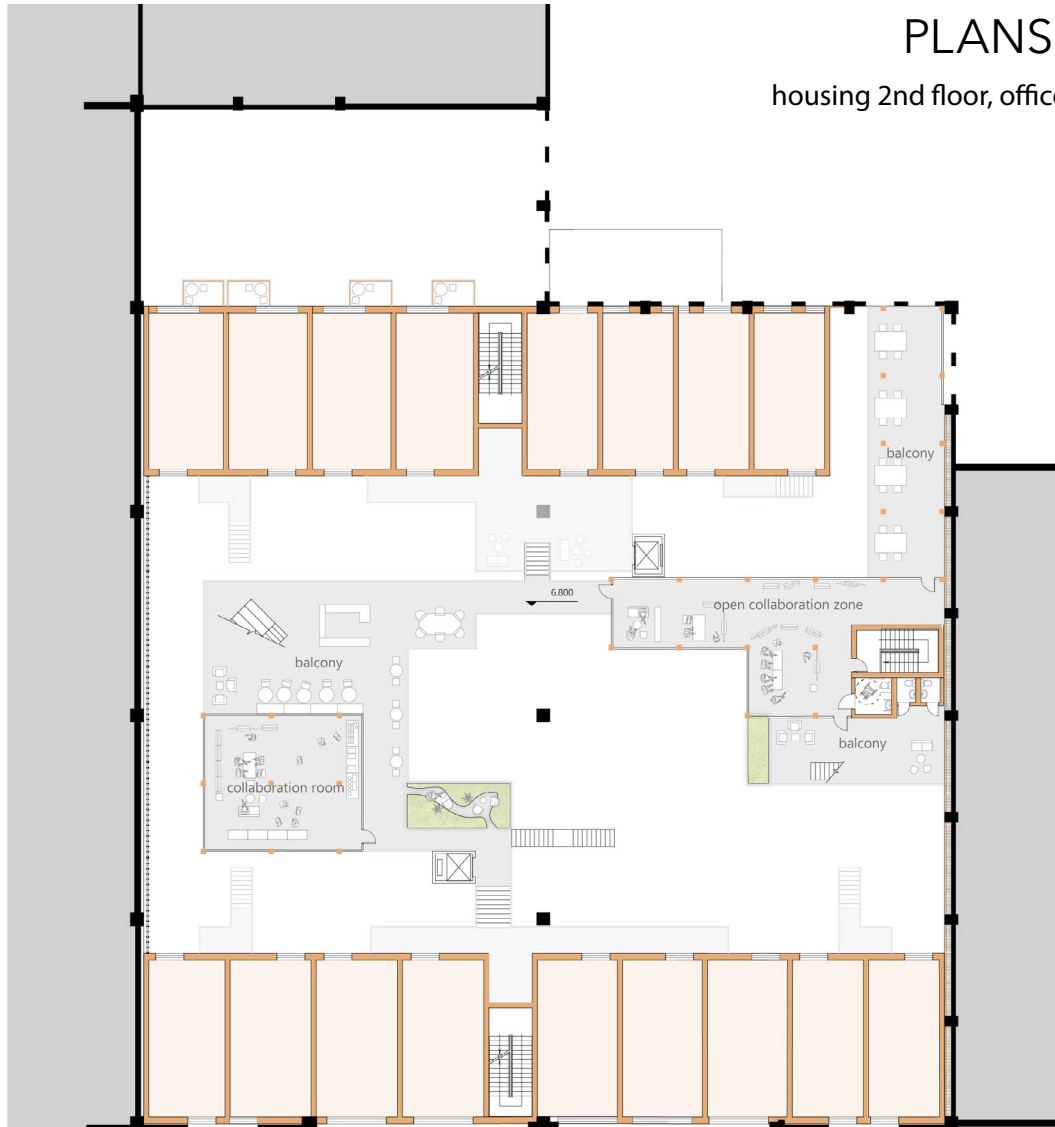

PLANS

housing 2nd floor, office 3rd floor

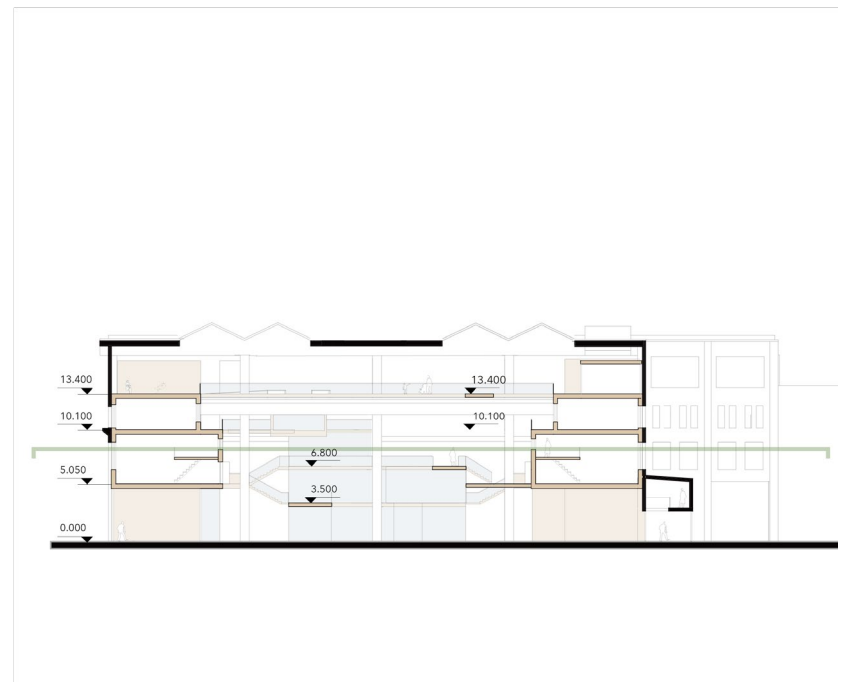
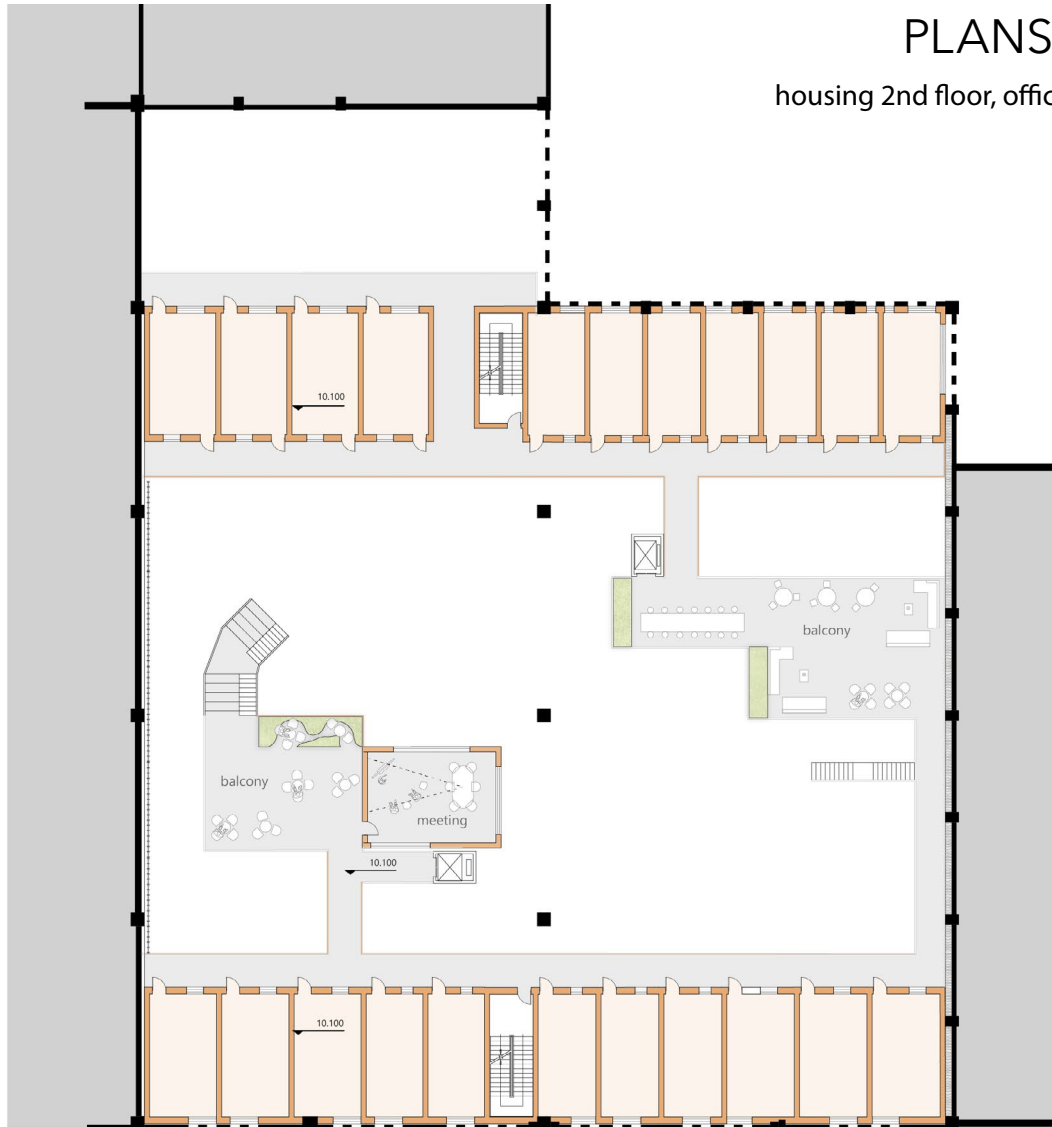

PLANS

housing 3rd floor, office 4th floor

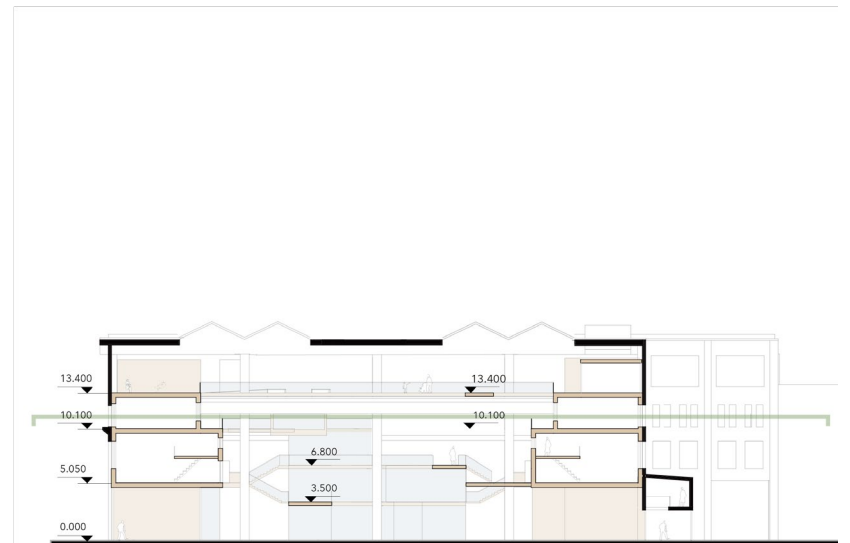
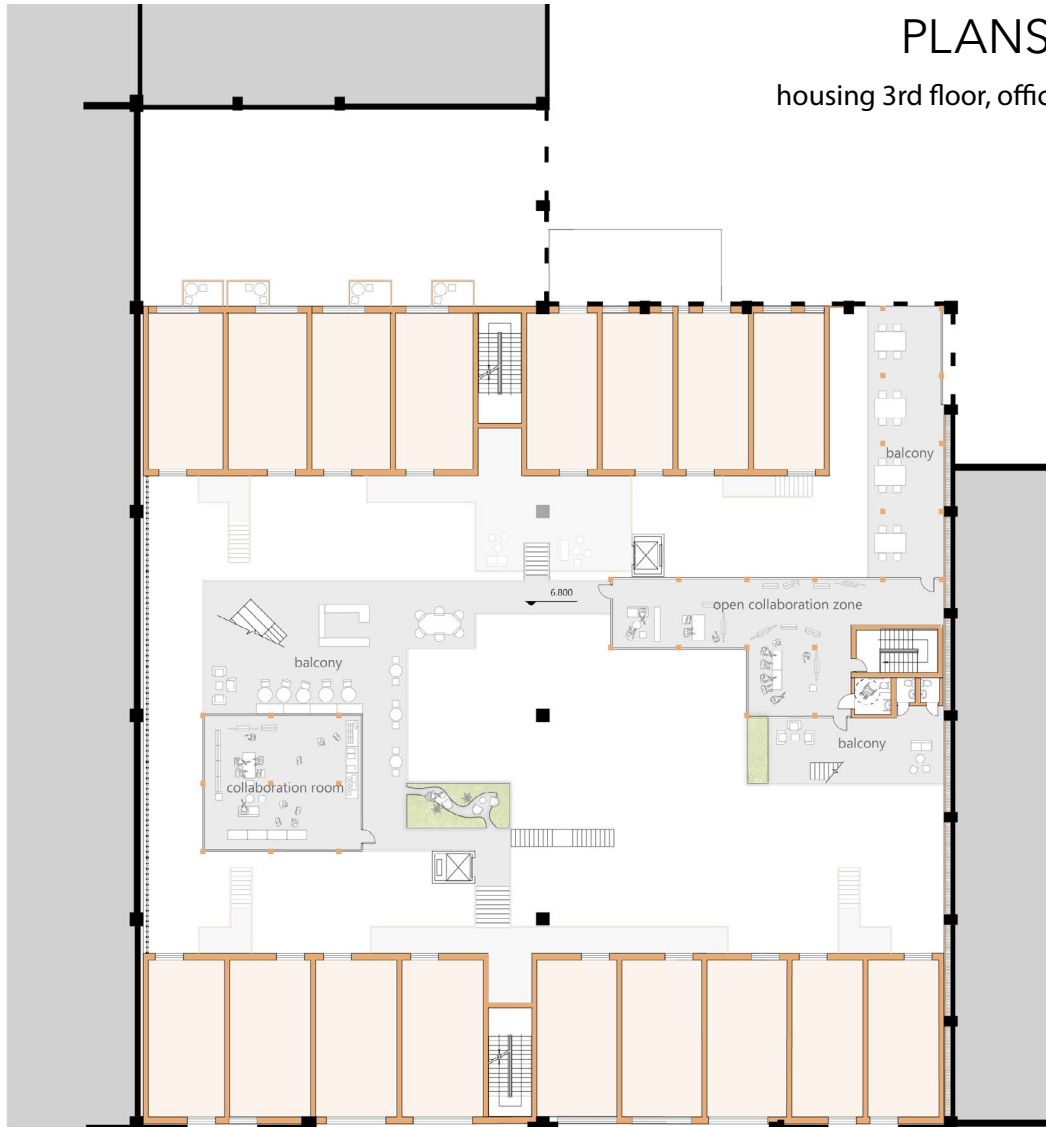

PLANS

housing 4th floor

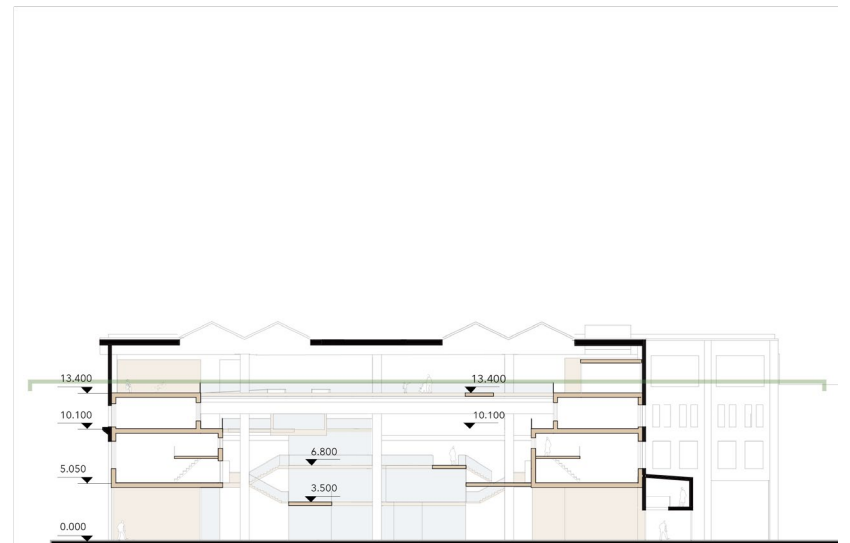
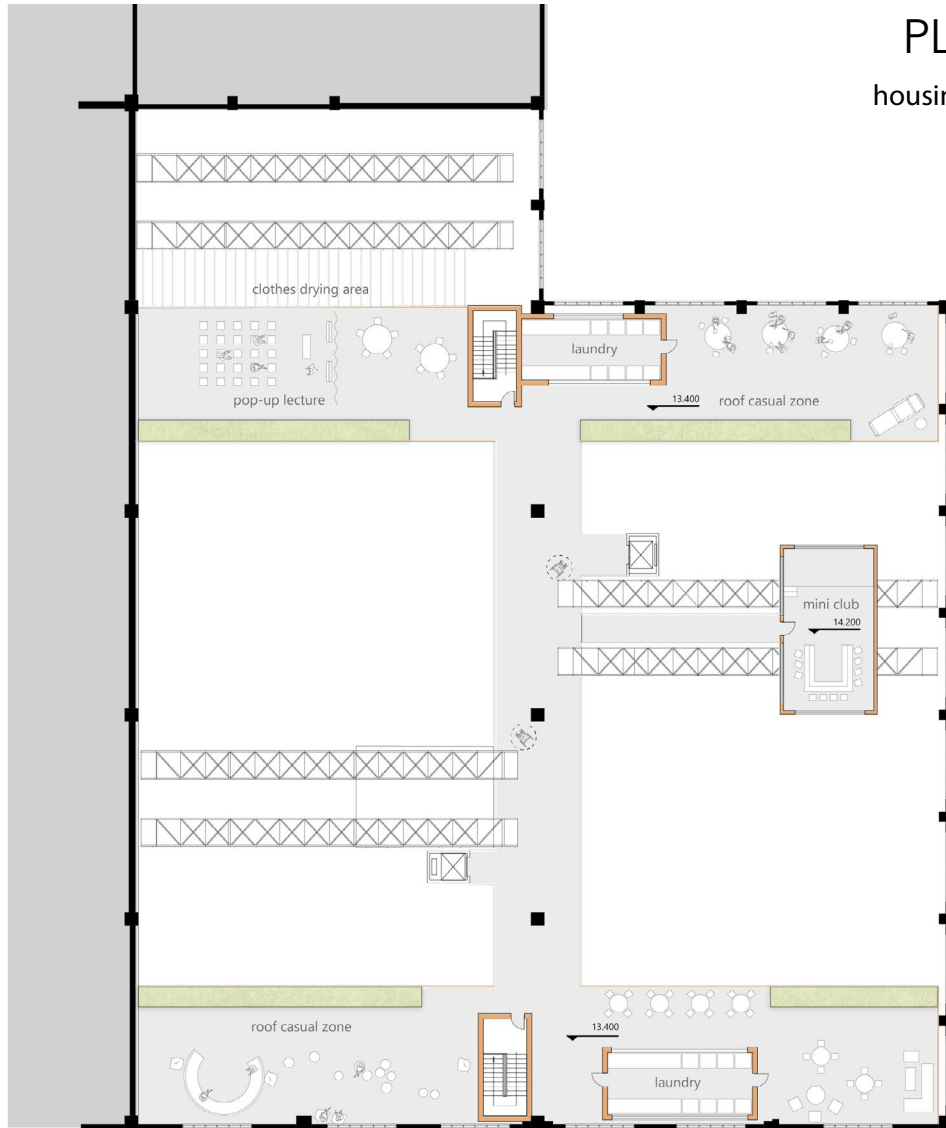

SECTION PERSPECTIVE

across housing unit, working space & restaurant





HOUSING UNITS

5 types of housing units



Out of consideration of simplifying manufacturing and assembling procedures, and by adapting to the facade openings' dimensions at the same time, reconciliation between the conflicts of different dimensions is needed. At the end, five types of housing units with different interior width was found to minimize the types of units inside Plåtverkstaden while having sacrifices as small as possible for daylight.

They are:

4700mm * 9300mm * 4650mm (interior) * 18 units

4150mm * 9300mm * 4650mm (interior) * 6 units

3950mm 7200mm * 2900mm (interior) * 10 units

3350mm 7200mm * 2900mm (interior) * 8 units

3100mm 7200mm * 2900mm (interior) * 4 units

in total 46 housing units.

In the following pages, the three types units with the biggest amount are chosen to be shown with more details.

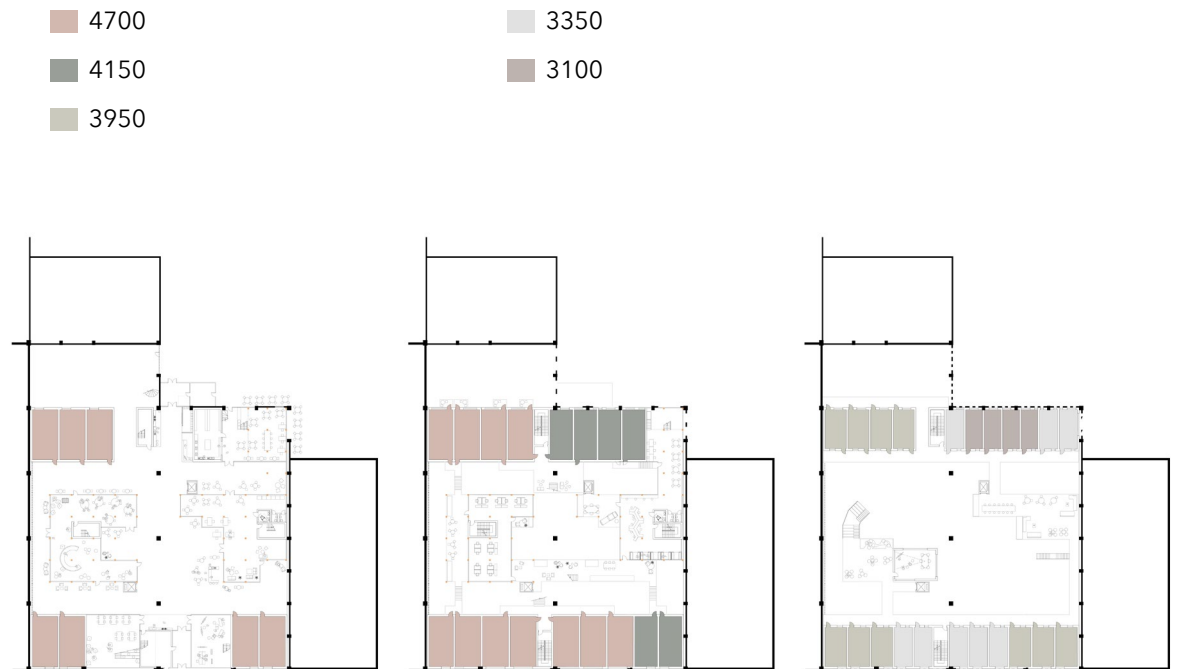

distribution in the three housing storeys

HOUSING UNITS

type 4700mm

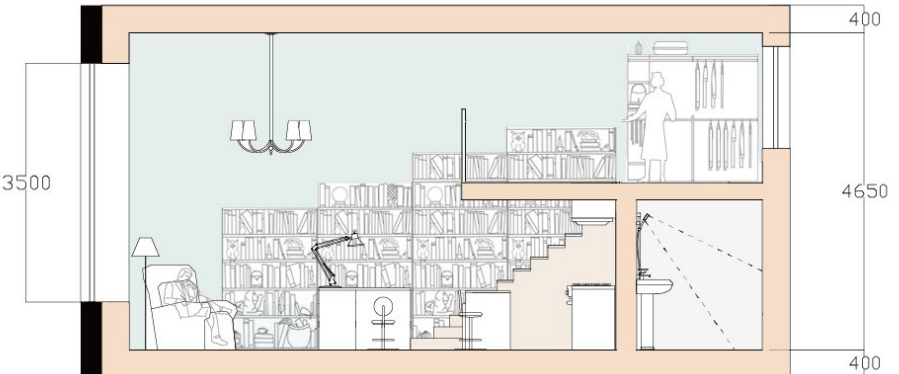
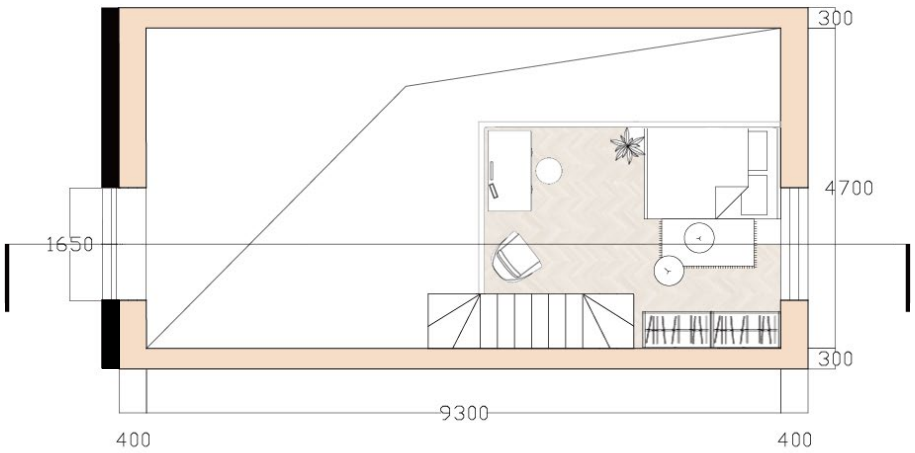
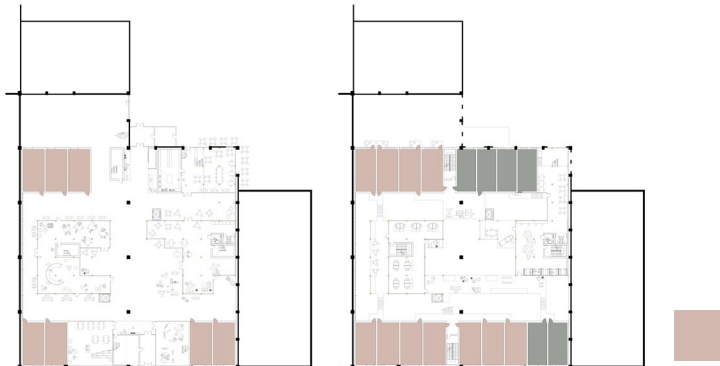
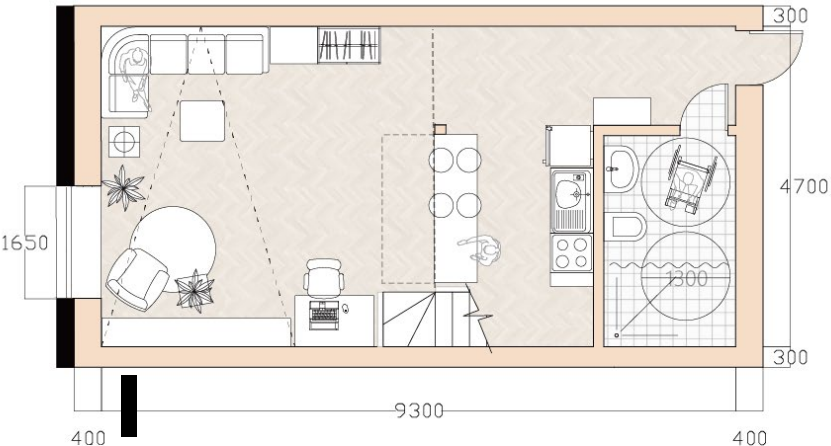

HOUSING UNITS

type 3350mm & 3950mm

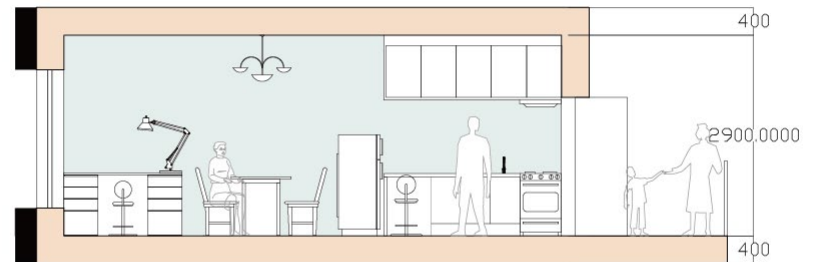
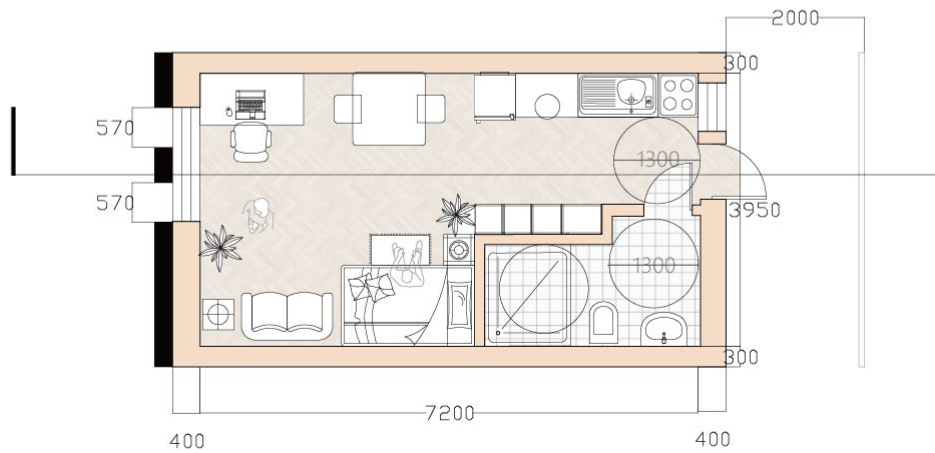
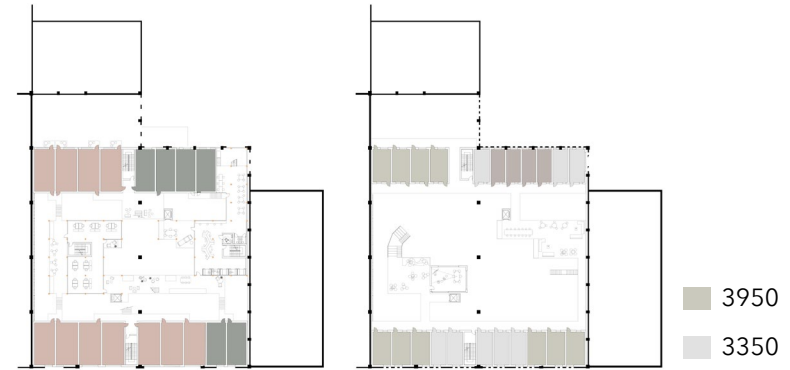
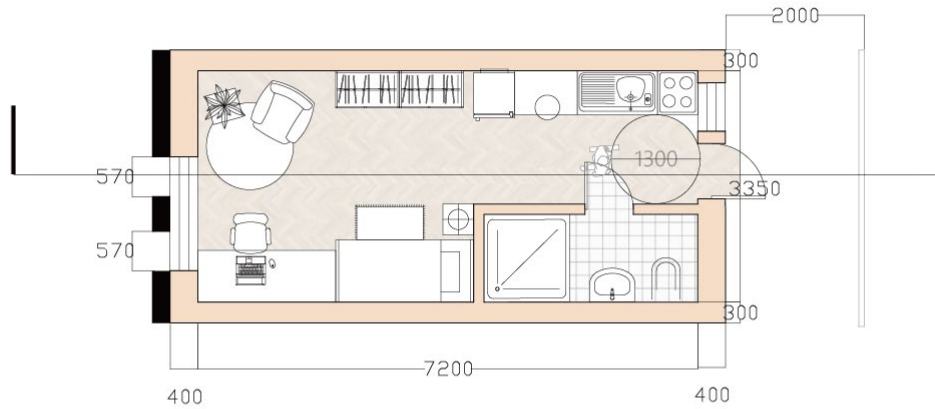

VISUALIZATION

ground floor space between housing and restaurant



VISUALIZATION

acoustic material selection, metal sheet and gate re-use, three types of railing



VISUALIZATION

view from the housing fourth floor balcony



VISUALIZATION

hidden garden for the tenants



VISUALIZATION

casual meeting spaces and hanging meeting room



VISUALIZATION

view from north-west entrance into restaurant and atrium



CONSTRUCTION DETAILS

Exterior wall, housing and working spaces

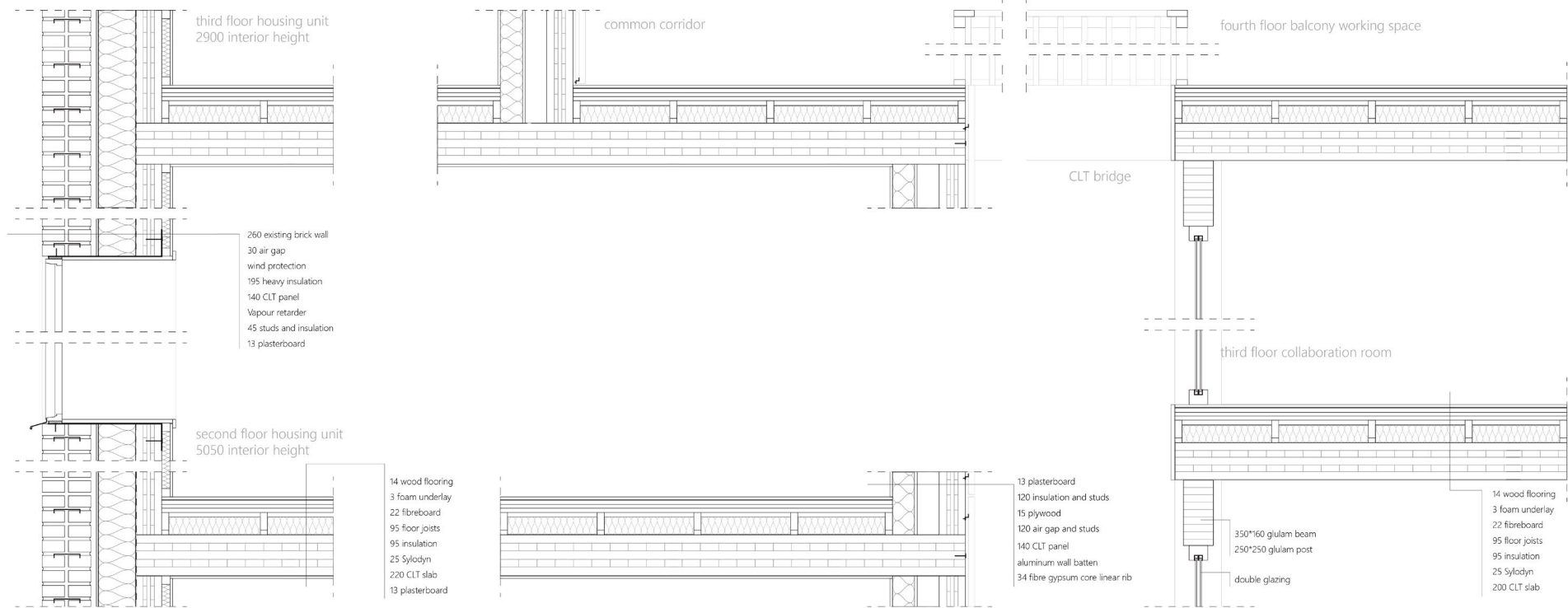

REFLECTIONS

about this design project

Method

- Comfort analysis as a tool instead of a goal

At the beginning of this thesis, the thesis question focuses on how to create a good indoor climate for the transformed building, along with other goals on the spatial and social aspects. It started to be a barrier for decision making soon. There appeared too many good intentions about comfort concepts and spatial usage concepts, it turned out difficult to prioritize them as all concepts lead somewhere fun yet different. And many of the times, comfort concept seems in conflict with the other experiences of the space, and vice versa.

It gradually became clear that, it is most efficient to use daylight analysis for suggestions on the envelope mainly, instead of for clues about how the interior layout should be, especially if the interior layout is not determined at all. This is because there are countless possibilities that an interior layout has good daylight performance. There need to be other goals that drive the design, with comfort analysis used for limited aspects or for fine-tuning the end result.

Thus, the thesis question was narrowed into finding a design solution to satisfy daily uses, with comfort analysis as a side tool. Henceforth the design process is much smoother.

Conclusion

This thesis investigates the possibility of converting Plåtverkstaden into a residential building via research-by-design and research-for-design methods. Throughout this process the attempt is to respond to contextual needs and prepare for future urban development, which suggests the potential market for short-term housing. Added values beyond housing functions are endowed to the building as well, such as encouraging interactions and collaborations to happen, bringing people from dissimilar backgrounds to the same platform of life, where they live, work, and step forward together.

The decision of using timber as the new material and the concept of "infill within existing envelope" not only provide reference for the transformation of similar buildings, but also attach educational significance for the tenants and users of this building regarding the idea of circular economy and sustainability.

REFLECTIONS

About transforming dis-used industrial building into housing

Challenges

- Envelope

Industrial buildings especially factories are usually wider and deeper in their plan dimensions compared to residential buildings. This creates the main challenge for creating indoor comfort in the transformation. Hence the existing openings and future potential for more openings on the building envelope are the most important evaluation criteria for one industrial building's transformation potential. To introduce daylighting, ventilation, and view, the ultimate decision to make is, which program should be prioritized to access the limited openings. In my design, housing are the top priority and layout of the program.

- Dimensions

Due to the fact that the facade of the building cannot be arbitrarily altered, the indoor floor height must adapt to the facade. This will pose a challenge to the organization circulation and positioning of programs, as it is not feasible to design using the two-dimensional mindset as designing common buildings. It becomes crucial to think about all the decisions in three-dimensional way.

Opportunities

- Spatial experience

The historical red brick walls with a grand scale of the building itself makes the experience inside the building very unique and memorable.

In *Delirious New York* Koolhaas describes the "Vertical Schism":

A prominent phenomenon in contemporary cities is Vertical Schism, which means that in a building, each floor is no longer related and dependent on each other, and can accommodate contents different as black and white.

Many industrial buildings have the potential to escape from this "Vertical Schism", for the scale of "space" they have indoor.

For us who are used to buildings designed for human, building designed for machines or storage is like an existing spatial wonder. For those industrial buildings located in the center of the city, they have an even higher public attributes. Thus, there is great value for utilizing them.

- Existing elements re-use

If the existing elements are retained, they can form distinctive and matchless spatial characters, which is a declaration of the industrial history of architecture. They can even possibly become part of the circulation or carry today's functions, making the manifestation of circular economy and sustainability.

- Utilize distinct features

Each factory may be unique architecturally, based on their original functions. So examining the distinct features within the building can result in new possibilities. For example, Plåtverkstaden has a deeper foundation than ordinary buildings because it was used to build ship sections, which inspires the concept of creating an indoor garden with the space for earth.

STUDENT BACKGROUND

Yuren Chen

Education

Chalmers University of Technology

September 2021 - now

Department of Architecture and Civil Engineering

Msc, Architecture and Planning Beyond Sustainability

École Polytechnique Fédérale de Lausanne

September 2022 - now

School of Architecture, Civil and Environmental Engineering

Master Exchange

Wuhan University

September 2016 - June 2021

School of Urban Design

Bachelor of Architecture

University of Dundee

September 2020 - June 2021

School of Social Sciences

BA in Architectural Studies with Wuhan University

- Planning and design for sustainable development in a local context(studio),
- Reality Studio(studio),
- Sustainable development and the design professions,
- Design Systems
- Exhibition design with timber structure(studio),
- Interactive conceptual design of structural forms,
- Comfort and architecture: sustainable strategies,
- Material and energy flow analysis,
- Experience design
- V&A Museum design with timber structure(studio),
- Highschool design(studio),
- Tech-Edu Highrise design(studio),
- Lake City design(studio),
- Adaptive-reuse Arthouse Cinema(studio),
- Kindergarten design(studio)
- Self-employed Village Design with Logistic System Planning(Thesis)

Work

CADI(Wuhan)

June 2019 - December 2019

Internship, Architecture

Competition,
Museum,
Rural Planning

SDD(Shanghai)

April 2020 - August 2020

Internship, Architecture

Residence,
Kindergarten

LIST OF REFERENCES & READINGS

Housing in Sweden

Berg, C., Hansen, S., Hallsten, K., Hesselman, M., Gerwin, J., Johansson, M., Lindé, J., Lindskog, M., Richards, C., Svensson, A., & Winstrand, J. (n.d.). -47 - sveriges riksbank economic review 2015:2 * The author wishes to thank in particular. Retrieved May 12, 2023, from https://archive.riksbank.se/Documents/Rapporter/POV/2015/2015_2/rap_pov_artikel_3_150917_eng.pdf

Götaverken

Bidragsgivare till Wikimedia-projekten. (2004, April 8). Götaverken. Wikipedia.org; Wikimedia Foundation, Inc. <https://sv.wikipedia.org/wiki/G%C3%B6taverken>

Semrén & Månsson - The Yard | Arkitektur | Projekt. (n.d.). Semrén & Månsson - the Yard | Arkitektur | Projekt. Retrieved May 9, 2023, from <https://semren-mansson.se/projekt/the-yard>

Gothenburg

Gothenburg's history and heritage. (n.d.). Wwww.goteborg.com. <https://www.goteborg.com/en/guides/gothenburgs-history-and-heritage>

From shipbuilding industry to Science Park | Lindholmen Science Park. (n.d.). Wwww.lindholmen.se. Retrieved May 9, 2023, from <https://www.lindholmen.se/en/about-us/history>

Lindholmens varv, Göteborg. Varvet 1961-10-03. (n.d.). Digitaltmuseum.se. Retrieved May 9, 2023, from <https://digitaltmuseum.se/021015640598/lindholmens-varv-goteborg-varvet-1961-10-03>

Din verksamhet -vår service VISITORS CENTRE. (n.d.). Retrieved May 9, 2023, from https://www.lindholmen.se/sites/default/files/2023-03/chrk_lindholmen_folder_digital_version_final_0.pdf

Lindholmen. (2022). Goteborg.se. <https://goteborg.se/wps/portal/start/goteborg-vaxer/hitta-stadsutvecklingsprojekt/stadsomrade-hisingen/lindholmen>

Temporary Concept

ACCOMMODATION FOR TEMPORARY WORK IN SWEDEN. (2018, June 1). Part-Time Home. <https://parttimehome.eu/en/accommodation-for-temporary-work-in-stockholm/>

What Is a Staffing Assistant? (n.d.). Small Business - Chron.com. <https://smallbusiness.chron.com/staffing-assistant-10504.html>

Tech skills shortage still a problem for employers | Computer Weekly. (n.d.). Computer-Weekly.com. <https://www.computerweekly.com/news/252529226/Tech-skills-shortage-still-a-problem-for-employers>

Transformation

Vast warehouse at San Francisco's Pier 70 becomes Gusto headquarters. (2018, October 6). Dezeen. <https://www.dezeen.com/2018/10/06/gusto-headquarters-warehouse-pier-70-san-francisco-gensler/>

46 Dwellings in the Former Fabra & Coats Factory / Roldán + Berengué. (2020, November 2). ArchDaily. <https://www.archdaily.com/950487/46-dwellings-in-the-former-fabra-and-coats-factory-roldan-plus-berengue>

Fitzroy Sheetmetal Factory | Kerstin Thompson Architects. (n.d.). Kerstinthompson.com. <https://kerstinthompson.com/index.php?id=29>

Kindesign, O. (2014, February 6). Light-filled duplex offers small design with huge impact in NY. One Kinding. <https://onekindesign.com/2014/02/06/light-filled-duplex-offers-small-design-huge-impact-ny/>

Uluışık, İ. (2019, January 29). Historical Industrial Buildings Transform into New Modern Spaces. Illustrarch. <https://illustrarch.com/articles/806-historical-industrial-buildings-transform-into-new-modern-spaces.html>

<https://www.almedalsgolv.se/vara-tragolv/kubbgolv/base/furu-2>

Regulations

(2015, February 3). Comparing nordic building regulations wrt some issues to do with access for all [Review of Comparing nordic building regulations wrt some issues to do with access for all]. <https://www.epikoda.ee/>. <https://www.epikoda.ee/wp-content/uploads/2014/07/Comparing-nordic-building-regulations-wrt-some-issues-to-do-with-access-for-all-2015.pdf>

LIST OF FIGURES



46 Dwellings in the Former Fabra & Coats Factory / Roldán + Berengué. (2020). ArchDaily. Available at: <https://www.archdaily.com/950487/46-dwellings-in-the-former-fabra-and-coats-factory-rolدان-plus-berengue>.

aerial look of Lindholmen. (n.d.). <https://goteborg.se>. Available at: <https://goteborg.se/wps/portal/start/goteborg-vaxer/hitta-stadsutvecklingsprojekt/stadsomrade-hisingen/lindholmen>.

Airbnb Offices Designed with Core Identity and 'Belong Anywhere' Philosophy - Gurgaon.. (2018). The Architects Diary. Available at: <https://thearchitectsdiary.com/airbnb-offices-designed-with-core-identity-and-belong-anywhere-philosophy-gurgaon/>.

construction details. (2019). Swedishwood. Available at: <https://www.swedishwood.com/siteassets/5-publikationer/pdf/er/clt-handbook-2019-eng-m-svensk-standard-2019.pdf>.

Fitzroy Sheetmetal Factory | Kerstin Thompson Architects. (n.d.). kerstinthompson.com. Available at: <https://kerstinthompson.com/index.php?id=29>.

future central Gothenburg's buildings. (n.d.). <https://goteborg.se>. Available at: <https://goteborg.se/wps/portal/start/goteborg-vaxer/hitta-stadsutvecklingsprojekt/stadsomrade-hisingen/lindholmen>.

Gotaverken Advertisement. (1934). <https://en.wikipedia.org/>. Available at: <https://en.wikipedia.org/wiki/G%C3%B6taverken>.

Lindholmens varv, Göteborg. Varvet 1961-10-03. OWNER OF COLLECTION SJÖHISTORISKA MUSEET. (1961). <https://digitaltmuseum.se/>. Available at: <https://digitaltmuseum.se/021015640598/lindholmens-varv-goteborg-varvet-1961-10-03/media?slide=0>.

Mansson, S. (2022). 'The Yard' Conceptual Design. semren-mansson.se. Available at: <https://semren-mansson.se/projekt/the-yard>.

One Kindedesign. (2014). Light-filled duplex offers small design with huge impact in NY. One Kindedesign. Available at: <https://onekindesign.com/2014/02/06/light-filled-duplex-offers-small-design-huge-impact-ny/>.

Stadsbyggnadskontoret (1987). GÖTAVERKEN/CITYVARVET, 36:A FRIHAMNEN,36:B KVILLETORGETMM,39:A SEBRÄMAREGÅRDEN,37:A RODDKLUBBENSUS,39:1. KULTURHISTORISKT VÄRDEFULL BEBYGGELSE I GÖTEBORG.

Stadsmuseets arkiv (n.d.). Plåtverkstaden. KULTURHISTORISKT VÄRDEFULL BEBYGGELSE I GÖTEBORG.

Statistics Sweden and the Riksbank (2015). housing construction and population changes in Sweden. sveriges riksbank economic review. Available at: https://archive.riksbank.se/Documents/Rapporter/POV/2015/2015_2/rap_pov_artikel_3_150917_eng.pdf.

kubb flooring examples. (2023). ArchDaily. Available at: https://www.archdaily.com/catalog/us/products/15112/wood-cladding-linear-rib-gustafs?ad_source=neufert&ad_medium=gallery&ad_name=close-gallery.

LUMIA, studio ARGUS (2020). winter garden idea reference. ArchDaily. Available at: <https://www.archdaily.com/986923/fahle-gallery-street-lumia-plus-studio-argus/62f29de8d0893a0170d3e510-fahle-gallery-street-lumia-plus-studio-argus-photo>.

Hermitage Museum (1865). The Winter Garden. WIKIMEDIA COMMONS. Available at: https://commons.wikimedia.org/wiki/File:Hau._Interiors_of_the_Small_Hermitage._The_Winter_Garden._1865.jpg.



CHALMERS
UNIVERSITY OF TECHNOLOGY