

# RESURRECTING HERITAGE

BRINGING NEW SPIRIT INTO A CHURCH RUIN

ZUZANNA MYSZKER

MASTER'S THESIS  
2024



**CHALMERS**  
UNIVERSITY OF TECHNOLOGY

Chalmers School of Architecture  
Department of Architecture and Civil Engineering

Examiner: Walter Unterrainer  
Supervisor: Tina Wik

# RESURRECTING HERITAGE

BRINGING NEW SPIRIT INTO A CHURCH RUIN

ZUZANNA MYSZKER  
MASTER'S THESIS 2024



Chalmers School of Architecture  
Department of Architecture and Civil Engineering

Architecture and Planning Beyond Sustainability  
Building Design and Transformation for Sustainability

Examiner: Walter Unterrainer  
Supervisor: Tina Wik

## ABSTRACT

This master's thesis project explores the topic of different approaches towards interventions on ruins as a sustainable approach towards heritage preservation. Given the growing worldwide interest in reusing existing resources and preserving the values, this work examines how strategic enhancement of the Sankt Pers church ruins in Sigtuna can bridge the gap between historic preservation and architecture renewal, while serving the local community.

The primary aim of this research was to understand, implement and develop the principles and practices that are common among transformation of historical sites, presenting unique possibilities for preserving their historical significance. It investigated several case studies on transformation performed in similar conditions, highlighting innovative design strategies, historical preservation techniques, sustainability features, and community engagement models. Basing the process on current and historical theories within the topic of transformation and cultural heritage, the project applies a multidisciplinary approach to shed light on best practices for such actions.

Social and cultural sustainability is an essential element of this research, therefore the project explores how such actions can influence people's understanding and appreciation of history and heritage. By using existing structures and incorporating contemporary additions, analysed projects and design proposed within this master's thesis contribute to the local historical environment.

Considering all factors, the objective of this master's thesis project was to explore how the transformation and adaptation of the St Pers church ruin's surroundings can effectively unite historical elements with contemporary architectural concepts, promote sustainability, and serve as a dynamic hub for historical preservation and education. The ultimate goal was to establish vibrant environments that harmoniously accommodate historical significance with the essence of modernity.

Keywords: transformation, sustainability, abandoned, ruins, heritage, culture, reprogramming

## AUTHOR'S BACKGROUND



*Zuzanna Myszker*  
ZUZANNA MYSZKER

## EDUCATION

September 2022 - June 2024  
Chalmers University of Technology; Göteborg, Sweden  
Department of Architecture and Civil Engineering  
Obtained title: **Master of Science**

October 2018 - January 2022  
Gdańsk University of Technology; Gdańsk, Poland  
Department of Architecture and Urban Design  
Obtained title: **Inżynier Architekt (Engineer Architect)**

## PROFESSIONAL BACKGROUND

Since July 2023  
**Freelance Architect & Designer;** Poland  
Architectural design, landscape design

February 2022 - July 2022  
**Assistant Architect in Szablowsky Architekci;** Gdansk, Poland  
Architectural and engineering design on smaller scale architecture in BIM software; coordination between industries

May 2021 - November 2021  
**Assistant Architect in DG Architekci;** Sopot, Poland  
Architectural and engineering design on small and medium scale architecture in BIM software; coordinating small projects

## SOFTWARE



Revit Archicad AutoCAD SketchUp Lumion Enscape Vray Aff. Designer, Publisher

## TABLE OF CONTENTS

01	/ INTRODUCTION	1
	PURPOSE AND AIM   EXPECTED OUTCOME   ISSUES AND DELIMITATIONS	2
	RESEARCH QUESTION	3
	BACKGROUND	5
	THEORIES	8
	SUSTAINABILITY	10
	LEGISLATIONS	11
02	/ CASE RESEARCH	13
03	/ SITE AND FUNCTION	21
	POSSIBLE SITES - ANALYSIS	22
	CHOSEN SITE: SANKT PERS CHURCH RUIN IN SIGTUNA, SWEDEN	26
	HISTORY OF SIGTUNA AND ITS CHURCHES - TIMELINE	28
	2019's RENOVATION	31
	RESIDENTS - SURVEY	34
	SITE IN CONTEXT	38
04	/ DESIGN PROPOSAL	41
	LANDSCAPE	42
	PLATFORM	52
	AUXILIARY BUILDING	60
	MATERIAL CHOICE	69
05	/ PROCESS AND METHODS	72
06	/ DISCUSSION	74
07	/ REFERENCES	76

### READING INSTRUCTIONS

The thesis starts with the explanation of the overall background introducing the subject and case studies in the area of interest. Then, the site is chosen and analysed. In the design proposal, chosen solutions are explained and analysed on several levels. The thesis is then summarised in the discussion, from the perspective of research questions stated in the beginning.

## PURPOSE AND AIM

The main purpose of this thesis is to conduct a culturally and socially sustainable transformation of the Sankt Pers church ruin's surroundings into a new, contemporary function serving the needs of the town's community. With focus on the preservation of historical remains, the project explores and visualises a way to integrate new architectural elements and structures with the existing ruin, creating a harmonious and functional space for public use.

## EXPECTED OUTCOME

The outcome of this thesis is a design proposal of the Sigtuna's church ruin transformation showcasing the sustainable approach towards historical significance and integration of old and new within architecture. The scale of intervention is defined as a building with landscape planning and contemporary additions, within and outside the ruin, while preserving current remains.

Some of the most important aspects of the final design are supposed to include an aesthetically pleasing, culturally meaningful and sustainable design, but also starting the new beginning for the history of the site, reducing the cost of future maintenance, a but also critically reflecting on the undertaken actions. The design itself should ensure a valuable experience while exploring the transformed church remains. Romantic spirit and functionality should be integrated and accentuated in the final proposal - **it should not end the history of the ruin, but give it a new drive and a fresh breath of life and purpose**, in order to simultaneously cherish, preserve, transform and extend the life of this artefact of the past into present and future experiences of the visitors.

## ISSUES AND DELIMITATIONS

The issues and threats related to this type of intervention are an indispensable element of work on protected historical objects. Structural stability of the remains, heritage value, accessibility or local law - these are only some of the problematic aspects that need to be taken into account while conducting such transformation. While indisputably important, this thesis will not focus on some topics discussed within the theme of church ruins transformation.

Firstly, the geographical aspect, as the design is located on a specific site in the town of Sigtuna and the proposals may not be relevant in other environment with different local law and overall situation.

The intervention will not lead to structural restoration to serve the primary, spiritual function along with the idea of continuity, as it is not longer relevant in the Swedish population that becomes more and more secular with time. Some theories also advocate for the transformation of sacred buildings into multi-faith or interfaith spaces, where people of different religions or beliefs can gather for dialogue and worship. This approach promotes inclusivity and religious diversity, which is as well irrelevant to the topic.

The design will be planned without revolve around any funding issues or legal considerations regarding the allowed extent of transformation within this specific site.

## RESEARCH QUESTIONS

How can the historical value of a church ruin be experienced by adapting and integrating contemporary functions for the local society, while creating a harmony and dialogue between old and new?

Can the history of the place be exposed through new architectural interventions?

Why should the historical value of the place be enhanced?

A half-ruined Romanesque church in Italy transformed into a concert-theatre space. Source: <https://www.beta-architecture.com/the-risen-church-matthias-pabst-florian-scharf/> (access: 17/10/2023)



## BACKGROUND

The topic of repurposing abandoned constructions and ruins for contemporary functions, has gathered increasing attention in recent years within the fields of architecture, heritage preservation and cultural studies. This interest, especially in ruins, is rooted in their recognition of the rich historical and architectural value contrasted with the need for innovative strategies to revitalise and sustainably manage them in modern society.

Discussions have revolved around the challenges of adapting the spiritual sites to meet the evolving needs of a secular society. This niche area has generated debates centred on the delicate balance between preserving the historical and spiritual significance of the ruins while reimagining their functions to align with contemporary society's needs.

"As some can reuse old-fashioned objects and repurpose them in order to value what's already at their disposal, so can buildings that are no longer used be reintegrated into the life of their community, yet with a few changes.

(...) It is no rocket science to figure out that if one building was abandoned it is most probably because it no longer served a purpose, thus the need for a fresh one.

There are, however, some types of buildings that raise quite a lot of polemics. Needless to say, it is about **religious architecture**. Besides their obvious symbolic dimensions, such sacred spaces are, after all, buildings meant to serve their communities and although it may sound cynical (perish the thought), they too occupy a certain area in the built environment. So why not reintegrating them into their communities when abandoned or even ruined?"<sup>[1]</sup>

This master's thesis has the potential to contribute to the perspective on the profession and ruin intervention topic by demonstrating how it can be a responsible and socially-useful way to serve the modern society by using old, valuable construction sites. Exploring various design strategies, the proposal faces with the issue of repurposing old buildings by examining cutting-edge concepts and methods, as well as raising awareness of how architectural interventions might engage with historical and cultural settings.

According to various dictionaries, "ruin" means, among others, a destroyed, decayed object, the downfall and destruction. It can also be defined as an act of damaging, devastating and disintegrating something irretrievably. This definition applies to various aspects of life, also architectural objects. Typically, a "ruin" is defined as the remains or remnants of a building or structure that was once complete and operational but has since fallen into a state of decay or disrepair. Ruins come in various sizes; they can be older like temples and castles, but also rather new, as 19th or 20th century remains. Depending on the setting and kind of ruin, they usually carry some historical, cultural and emotional significance.

A ruin is essentially a construction object made by human hands; it now stands as a reminder of its former use, frequently with few functionalities still present. This state of deterioration, caused by the unstoppable passage of time or catastrophic accidents, enables it to be seen as a "sign of the times", more like ornamental relics than structural foundations.

Ruins merge with the natural world, as if reclaiming their place in the environment. Any ruins of a place of worship or spirituality are referred to as "church ruins". For those who practice the faith connected to the building, seeing a church ruin can be emotionally challenging. It might serve as a place of appreciation and spiritual reconnection for them; they can experience deeply religious or meditative feelings. Church ruins may receive special consideration for preservation and restoration efforts by religious or historical organizations due to their importance in terms of religion and culture. These initiatives seek to safeguard the church's cultural heritage with its unique religious and spiritual dimension.

"the disordered materials of considerable constructions diminished by the passage of time(...) only the square outline remaining intact(...) because some of these columns remain standing, with fragments of others and a quantity of bas-reliefs and unknown characters that demonstrate the grandeur and magnificence of ancient architecture." [Diderot and d'Alembert, Encyclopédie, 14:433.]<sup>[2]</sup>

"Should time make roofs collapse, nature will sprinkle them with flowers; should time crack open a tomb, nature inserts there the nest of a dove ceaselessly reproducing itself; nature wraps death in the gentlest illusions of life." [Chateaubriand, Génie du christianisme, 40–41]<sup>[3]</sup>

"In other terms, the charm of a ruin consists in the fact that it presents a work of human effort while giving the impression that it is a work of nature. The same forces of disaggregation, erosion, collapse, and vegetative invasion that give a mountain its outline here are seen at work on walls." [Georg Simmel, Réflexions suggérées par l'aspect des ruines," in La philosophie de l'aventure, trans. Alix Guillaïn (Paris: L'Arche, 2002), 50–51.]<sup>[4]</sup>

What should be done with a ruin, then? According to some - to preserve the entirety of the 'leftovers' within, giving the ruin a new lease on life. Remaining open to all the transformation possibilities, even considering expansions and additions that harmonize with the remnants of the past, are essential.

In the paper "Génie du christianisme", a French author and politician François-René de Chateaubriand states:

"There are two kinds of ruin, one being the handiwork of time, the other the handiwork of man.

The former are not in the least disagreeable because nature works side by side with the years. Should time make roofs collapse, nature will sprinkle them with flowers; should time crack open a tomb, nature inserts there the nest of a dove ceaselessly reproducing itself; nature wraps death in the gentlest illusions of life.

Ruins of the second type are more devastations than ruins. They give only the image of nothingness with no restorative power. The work of misfortune rather than of years, these are like white hairs on a young head. Human destruction is moreover more violent and more total than the destruction wrought by time: time undermines, mankind overthrows."<sup>[5]</sup>

This quote suggests, that ruins can portrait the harmony with nature, but also the abrupt and devastation inflicted by humanity.

The biggest world's heritage organisation UNESCO whose primary goal is to support international cooperation in the field of culture, art and science, in the Operational Guidelines for the Implementation of the World Heritage Convention, §86, explains the approach towards reconstruction:

"Justifications for reconstruction:

(...) Continuing function or re-use. The reconstructed building can continue to serve its previous function or makes possible a new, different function. (...)"

"Arguments against reconstruction:

A. The evocative value of ruined buildings. A ruined building left as it is can be more evocative of the past than that same building reconstructed."<sup>[6]</sup>

Analysing this paragraph, one can come up with a conclusion that the idea of giving the decayed building a new function is a possibility, as re-use is one of the ways to preserve the heritage. There is also an argument against it, saying that the history may be better shown by the ruin left as it is.

However, in this thesis' case, the Sigtuna town is a place where 3 known ruin churches are located. Considering that situation, the sustainable transformation of one of the ruins is a risk that can be taken into consideration for research and field development purposes, as it can possibly serve the local community and bring advantages to both everyday life there and the view on cultural heritage of the town.

## THEORIES

In the theoretical papers about church ruins transformation, there are two main approaches and opinions on the topic. Among specialists with positive attitude towards repurposing those sites, is Eugène Viollet-le-Duc, a French architect and art historian, who stated :

“the best of all ways of preserving a building is to find a use for it, and then to satisfy so well the needs dictated by that use that there will never be any further need to make any further changes in the building. In such circumstances, the best thing to do is to try to put oneself in the place of the original architect and try to imagine what he would do if he returned to earth and was handed the same kind of programs as have been given to us.”<sup>[7]</sup>

ICOMOS, the international council on monuments and sites, includes this article in The Venice Charter from 1964:

“The conservation of monuments is always facilitated by making use of them for some socially useful purpose.”,

meanwhile later they state that

“Such use is therefore desirable but it must not change the lay-out or decoration of the building. It is within these limits only that modifications demanded by a change of function should be envisaged and may be permitted.”<sup>[3]</sup>, which indicates that there should be no intervention within the building mass and area. However, because of this thesis being speculative, the focus will stop on the first sentence of this article.”<sup>[8]</sup>

“(…) the Council of Europe issued a recommendation concerning cathedrals and other major churches (…) the recommendation deals in particular with how these great buildings to be managed and preserved against a background of the major costs involved. It also touches on the need for adaptation, for example, multiple use ("multifunctional use") and how different faiths regard this:

“The religious communities have very different attitudes to the physical heritage. Some (such as the Orthodox and Roman Catholic Churches) regard the buildings and their contents as sacred. Others (such as most Protestant Churches) are very much open to multifunctional use of the premises. These differing attitudes should be respected for major religious buildings that are still in use. (Council of Europe 2000b)”<sup>[9]</sup>

William Morris' approach is an example of one leaning towards exclusively preservation without any structurally unnecessary actions. In his Manifesto of the Society for the Protection of Ancient Buildings he used to say:

“(…) if it has become inconvenient for its present use, to raise another building rather than alter or enlarge the old one; in fine to treat our ancient buildings as monuments of a bygone art, created by bygone manners, that modern art cannot meddle with without destroying.”<sup>[10]</sup>

This quote suggests that the contemporary intervention may be a threat to the beauty and art of ancient buildings with risk of destroying it. It advises that building another structure is a better option in case of new societal needs and modern functions.

The Fourth Congrès Internationaux d'Architecture Moderne (CIAM) in 1933 was a significant architectural conference that focused on the theme of "The Functional City." It played a crucial role in shaping modern architecture and urban planning principles, emphasizing functionality and efficient design in urban environments. Among other, it also discussed historic heritage:

“Historic objects (separate monuments or sectors of the city) must be retained:

~ When its existence is not bought at the price of bad living conditions for the population that is compelled to live in it.

- When the opportunity is afforded to remove its restricting influence on development by the diversion of traffic round it or the shifting of the focal point,

An aesthetic adaptation of new parts of the city to the historic area has a catastrophic effect on the development of a city and is in no way to be desired. By the demolition of slum dwellings surrounding the historic monuments, green areas can be created, which improve the hygienic conditions in those areas”<sup>[11]</sup>

The analysis of the mentioned statements and other research papers can develop an opinion on the topic of repurposing the historic sites. Despite the negative approach of some, the time aspect should be taken into account. The last 50 years has been the era of the fastest development of human society and technology in the history, which resulted in changes of opinions and approaches. Theories constantly shift and risky interventions should be implemented to observe the consequences and learn from their outcome.

## ENVIRONMENTAL SUSTAINABILITY

Sustainable transformation in architecture can be defined as redevelopment of buildings and environments with a focus on climate and waste responsibility, energy efficiency and human well-being. It aims to reduce the harmful effects that the built environment has on the area and people who live there, but also overall on the planet. Additionally, the importance of factors like natural lighting and indoor air quality is prioritized in sustainable architecture. While promoting social and ecological sustainability, it aims to provide healthy and functional spaces. Through sustainable transformation, architects work to address global problems like climate change, resource shortage, and urbanization issues, addressing a more environmentally-friendly and peaceful coexistence between the built environment and the natural world.

Despite the principles of environmental sustainability being the desirable practises of general building projects, when discussing the topic of transformation conducted on a relict building's ruin, they may not be relevant and may even seem artificial or distracting from the main conceptual and artistic core.

However, Concious well-aging material selection is crucial for any sustainable restoration or transformation work, as it has a direct influence on the whole venture increasing the long-term viability of the project, but also keeping up with the ruin's state. Future long-term planning includes further maintenance work, costs of use and possible financial benefits for the town. The recommendations for energy usage and community engagement monitoring of the new volume, as well as prognosis on remains and new material deterioration and conservation requirements, should be considered.

## CULTURAL SUSTAINABILITY

Architecture plays a significant role in shaping cultural identity. Buildings and urban spaces can serve as symbols of cultural heritage and offer a sense of continuity for the community. Engaging them in decisions about new purpose of their well-known places can help ensure that it aligns with their cultural needs and desires. Also, designing spaces that encourage social interaction and gatherings can foster a strong sense of community and cultural sustainability.

Cultural sustainability in terms of architecture and society refers to the preservation and continuation of cultural heritage, traditions, and values through architectural and urban development practices. It emphasizes the importance of preserving and celebrating cultural heritage in the built environment and involves creating spaces that not only respect and celebrate the cultural identity of a place, but also ensure that this identity is maintained and enriched for future generations.

Understanding the history, traditions, and aesthetics of the local culture to ensure that new structures harmonize with the existing environment, is crucial. Also, reprogramming projects held in the area can interest people, raise awareness, help understand the importance of their cultural heritage and motivate them to participate in its preservation. This approach not only protects cultural identity but also contributes to sustainable and vibrant communities.

In this specific project, the focus will be directed towards the cultural, urban and social aspects of sustainable transformation, expanded in the further investigation.

"[P]reservation is no longer a retroactive activity but becomes a prospective activity."<sup>[12]</sup>  
REM KOOLHAAS, 2004

"Rehabilitation is defined as the act or process of making possible a compatible use for a property through repair, alteration, and additions while preserving those portions or features which convey its historical cultural or architectural values."<sup>[13]</sup>  
U.S. SECRETARY OF THE INTERIOR, 1995

"Rehabilitation acknowledges the need to alter or add to a historic property to meet continuing or changing uses while retaining the property's historic character."<sup>[14]</sup>  
U.S. DEPARTMENT OF THE INTERIOR, 2016

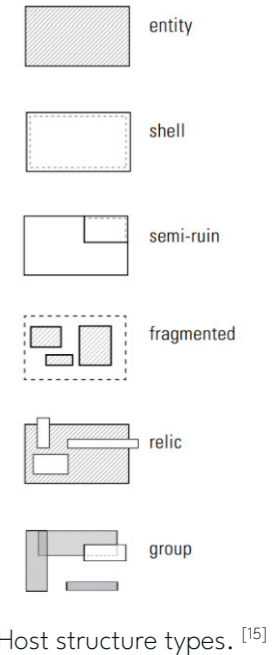

## LEGISLATIONS

Some general principles and guidelines apply to the protection and reuse of cultural heritage, including religious buildings, in the European Union. One of the fundamental principles is that the EU recognizes the value and potential of cultural heritage for social cohesion, intercultural dialogue, economic development and environmental sustainability.

The Faro Convention on the Value of Cultural Heritage for Society promotes advancing a people-centered approach to cultural heritage that respects the meanings and values people associate with their heritage and encourages their participation in its preservation and management. Its strategy for dealing with church ruins is to give the historic groups the capacity to preserve, restore, or reuse them for economic, social, or cultural objectives, but also to encourage bottom-up, people-driven action, involving all stakeholders in the decision-making and management of their legacy.

Swedish National Heritage Board passed an act about the preservation of historically valuable objects. Historic Environment Act (1988:950) <sup>[16]</sup> states, among others:

"Church buildings and church plots shall be conserved and maintained so that their cultural and historical value is not reduced and their appearance and character are not distorted.

(...) 'cultural object' means an object that is regarded in the state from which it has been removed as a national treasure possessing artistic, historical or archaeological value (...)"

This act suggests a lot of scope for the specialists to interpret the buildings' modifications regarding its cultural historical value, but it has to be accepted by the administrative board. It allows to speculate about the church ruins' transformation possibilities.

# CASE RESEARCH

TRANSFORMING, ADAPTING, REPROGRAMMING

## CASE STUDY #1

### Spanish gothic church ruins of Vilanova de la Barca

#### HISTORY & AIM

The church was bombed during the Spanish Civil War in 1936 and it's remained as a ruin since. The aim of the project held by AleaOlea architecture & landscape design studio was to uncover the remaining parts, restore them and transform into a new function, which is multi-purpose hall.

#### RESULT

The preservation of church ruins while restoring its original appearance and adding contemporary fill-ins to the structure, including new roof, prevented it from further deterioration. The architects however focused on visibly differentiating new and old by using contrasting colors and textures between the old and new parts. Another step was accentuating the beauty of raw walls with precisely designed interior lighting. Then, by adapting the interior for a multi-purpose hall, the project gave this place a new life and potential for flexibility further functional changes in the future. The final effect is a successful example of a mix of adaptive reuse and reprogramming the space.

#### MATERIALS

Original: stone ashlar || New: brick lattice wall, gabled roof tile

#### CONCLUSIONS

The positive outcomes of this projects include breathing new life into a historical and culturally significant site, preserving its heritage while making it accessible and useful for contemporary purposes. The project showcased innovative architectural techniques and design principles that could be an inspiration for future preservation and adaptive reuse projects. However, there is a risk of losing the authenticity and historical significance of the ruins through modern interventions. The aspects that could be useful for future research and design could be **the priority of preserving the remains, engage with local communities to ensure their involvement, and consider the long-term sustainability and maintenance of the transformed site to ensure its continued impact and relevance.**

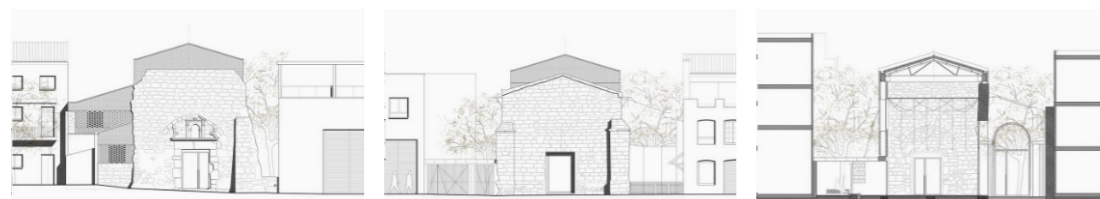

Elevations and sections after transformation. Source: <https://www.archdaily.com/803620/santa-maria-de-vilanova-de-la-barca-aleaolea-architecture-and-landscape> (access 02/02/2024)



Photos of the church's interiors after the intervention. Source: <https://www.designboom.com/architecture/aleaolea-church-vilanova-de-la-barca/>

## CASE STUDY #2

### Mediaeval Irish church in Kilkenny reborn as a museum

#### HISTORY & AIM

This 13th century church was deteriorated, but not yet a ruin. Thanks to the transformation project by McCullough Mulvin Architects, further decay was prevented. The transformation project by McCullough Mulvin Architects prevented further decay.

#### RESULT

Made from stone, the church's structure was still stable, although timber roofs needed restoration. The intention of this project was to restore the church into a museum, but also to honour the medieval spatial complexity of the site by reconstructing the north aisle and chancel on the original plan, but with a contemporary shape finished in lead. The contemporary extensions are covered in lead that is supposed to blend with the sky, not taking the attention away from the original building. The project is an example of a successful reprogramming of a historical site. The new function being a museum connected to the church's history, is a great way to preserve the heritage and remembrance of the site.

#### MATERIALS

Original: timber roof construction, stone walls || New: timber, lead, carved limestone

#### CONCLUSIONS

This architectural transformation resulted in several positive outcomes. The preservation of the historic building allowed visitors to experience its rich cultural heritage firsthand. However, there were also some negative aspects to consider. The transformation may have altered the original structure and aesthetic of the church, potentially diminishing its historical integrity. There may have been concerns about the commercialization of the site, with the museum being more focused on attracting tourists rather than respecting the sanctity of the church. For future projects this type, it could be useful **to strike a balance between preserving the original architecture of historic buildings while also allowing for adaptive reuse by careful planning and consultation with heritage preservation experts.**

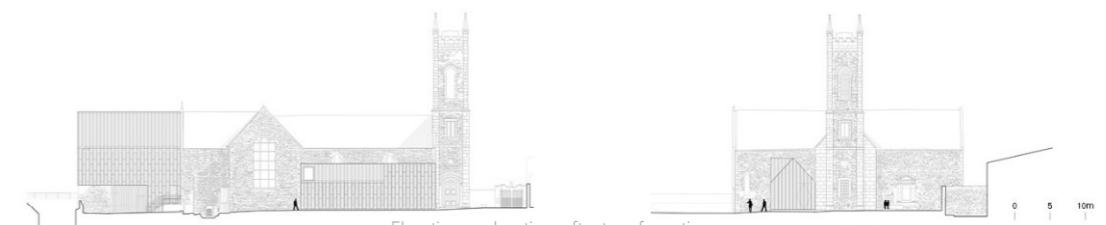

Elevations and sections after transformation. Source: <https://c3diz.net/medieval-mile-museum-by-mccullough-mulvin-architects/> (access 02/02/2024)



Source of the left picture: <https://c3diz.net/medieval-mile-museum-by-mccullough-mulvin-architects/>; Source of the right picture: <https://thespaces.com/medieval-irish-church-is-reborn-as-a-museum-in-kilkenny/> (access 17/10/2023)

### CASE STUDY #3

#### Church St. Paraskeva in Nessebar, Bulgaria restored

##### HISTORY & AIM

The whole city of Nessebar is listed in the UNESCO World Heritage List, so any construction work needs to obey specific regulations. This 13th century church was partially ruined because of time. This church has been renovated and transformed guided by the design of 4 independent architect in order to prevent further decay and visualise the original state of the church.

##### RESULT

The wall remains reflect Medieval Bulgaria's aesthetic principles with richly ornamented facade compositions. This adaptive reuse project successfully reconstructed a portion of the deteriorated structure while maintaining historical integrity. Interventions followed conservation standards, uncovering the original substance and respecting the object's historical stages. Only elements with concrete evidence were restored, minimizing speculative restoration. The new materials complement the old structure and the intervention is reversible. The new informational hub inside, with occasional exhibitions and concerts, respects the structure's integrity for potential future adaptations. Cor-ten steel sheets were used to match the original church's color and brick layout, creating a contemporary visual while maintaining harmony with the historical context.

##### MATERIALS

Original: stone, bricks, wooden beams || New: Cor-ten sheets

##### CONCLUSIONS

The restoration preserved the site's heritage, improved its aesthetic appeal, and boosted tourism while fostering local pride and identity. However, the high cost of restoration projects and the challenge of balancing modernization with historical preservation are potential drawbacks. Thorough research and planning before restoration can ensure sustainability and cost-effectiveness. Innovative design techniques can enhance the longevity of the restored structures, as demonstrated in this successful project.



Source: <https://www.archdaily.com/573012/conservation-restoration-and-adaptation-of-church-st-paraskeva-te-architects> (access 17/10/2023)

### CASE STUDY #4

#### Protective building for Hamar church ruins in Norway

##### HISTORY & AIM

The church was originally built in 12th-13th century in the Romanesque architectural style. It was demolished in 16th century during a war. Designed by Kjell Lund and Nils Slaatto Architects, the winning project had a goal of protecting the 950 years old church remains since 1998 for future.

##### RESULT

The protective structure over the Hamar church ruin is the biggest glass building in Europe. The "cathedral of steel and glass" allows the place to function as a multi-purpose space, combining the historical spot with concert and theatre scene. It created a modern, acoustic hall, suitable for performances and religious purposes. The shape of the whole structure derives from the cathedrals and church roofs, soaring upwards into the sky; it is also positioned in accordance to the original floor plan. Protecting the fragile stone from the outside will enable future archeological research on site.

##### MATERIALS

Original: stone || New: steel, glass

##### CONCLUSIONS

The transformation of the historical ruins with a new structure provided protection for future generations, while enhancing visitor experiences with improved access and educational information. Despite its cultural and historical significance, the protective cover has raised concerns for resembling museum walls rather than enhancing the site's history. Suggestions have been made to carefully consider future design in relation to the historical context, prioritizing the preservation of the site's history while also providing necessary protection and amenities for visitors. This balanced approach can ensure that future projects successfully meet the needs of preservation and accessibility of the site.

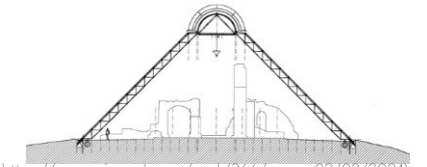

Section. Source: <https://www.miesarch.com/work/366> (access 02/02/2024)

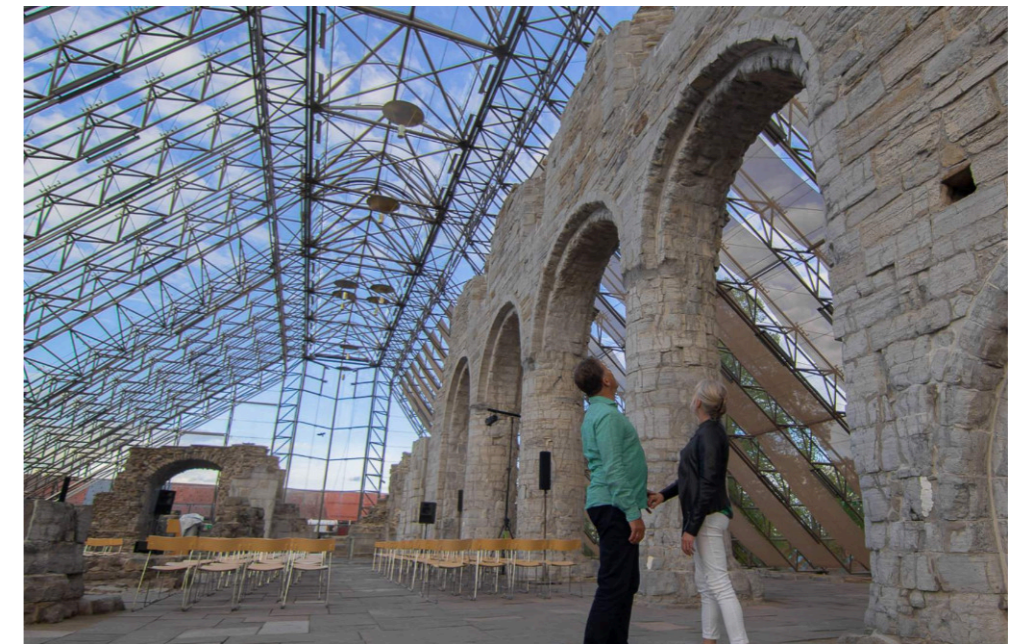

Source of the right picture: <https://www.visitnorway.com/listings/damkirkeodden/8732/> (access 04/05/2024)

## CASE STUDY #5

### Szatmáry Palace in Hungary reconstructed

#### HISTORY & AIM

Szatmary Palace in Pécs, Hungary, originally constructed in the 16th century by Bishop György Szathmáry, was in ruins in Tettye Valley. The project aimed to redefine its significance while preserving its historical layers. Interventions aimed to maintain its complexity while updating its context, focusing on enhancing the ruin's character and integrating the park and palace into a unified entity.

#### RESULT

In 2011, the MARP architecture studio reconstructed Szatmary Palace by adding an L-shaped steel structure on the south-eastern side, which featured a lookout tower, stairs, and technical facilities for theater use. The new addition framed city views, enhancing the palace's appeal, while surfaces were adapted to meet current public space needs. A new stage was installed in the ruin's Western wing for theatrical purposes, maintaining the incomplete state of the ruin. Green areas were replanted around the site, revitalizing its surroundings and restoring some of its original unity. The lookout tower provided picturesque city views and revealed inner parts of the ruin, blending modern functionality with historical significance in a harmonious architectural landscape.

#### MATERIALS

Original: stone || New: cor-ten steel

#### CONCLUSION

Some useful insights for future transformations of historical sites like Szatmary Palace include a **respect for historical context, integrating the structure with its surroundings, and embracing adaptive reuse over strict reconstruction. Thoughtful material selection, public engagement, and sustainability** are also crucial considerations. By **involving the community, selecting materials that blend old and new, and prioritizing sustainability**, transformations can honor the site's heritage while meeting contemporary needs. A long-term vision ensures interventions contribute to the site's ongoing relevance and vitality, creating vibrant spaces that preserve the past and serve future generations.



Source: <https://www.archdaily.com/272346/szatmary-palace-marp> (access 04/03/2024)

## CASE STUDY #6

### Helfštýn Castle Palace Reconstruction

#### HISTORY & AIM

The Helfštýn Castle Palace Reconstruction project aimed to restore and revitalize the historic palace located within Helfštýn Castle in the Czech Republic. The palace has a rich history dating back to the 14th century and has undergone various modifications and alterations over the centuries. The project's goal was to preserve the historical significance of the palace while adapting it to modern use and enhancing its appeal to visitors.

#### RESULT

As a result of the reconstruction, the palace has been restored to its former glory, with careful attention paid to historical detailing and architectural features. The site now serves as a cultural and tourist attraction, offering visitors a glimpse into the past with guided tours and exhibitions. The visual impact of the reconstruction is significant, as the palace now stands as a beautifully restored focal point within the castle complex.

#### MATERIALS

Original: stone, timber || New: cor-ten steel

#### CONCLUSION

Conclusions drawn from this project emphasize the importance of thorough research, careful planning, and collaboration with experts in historical preservation and conservation. **Attention to detail and commitment to preserving the original character of the site were essential elements in the success of the project.** For future similar projects, it is crucial to prioritize historical accuracy, sustainability, and community engagement. **Conducting thorough site assessments, utilizing local materials and craftsmanship, and fostering partnerships with heritage organizations and authorities are key considerations.** Additionally, ongoing maintenance and conservation efforts are necessary to ensure the long-term preservation of the restored site for future generations to enjoy.



Source: [https://www.archdaily.com/951016/helfstyn-castle-palace-reconstruction-atelier-r/ad\\_medium=gallery](https://www.archdaily.com/951016/helfstyn-castle-palace-reconstruction-atelier-r/ad_medium=gallery) (access 04/03/2024)

SITE AND FUNCTION

## POSSIBLE SITES - ANALYSIS

	Kärnbo	Sankt Pers	Drottens
TOWN	Mariefred	Sigtuna	Visby
AREA	60km from Stockholm	30km from Stockholm	Gotland
POPULATION ( <a href="https://citypopulation.de/en/sweden/">https://citypopulation.de/en/sweden/</a> )	4265 (2020) - town 1692/km2 36544 - Strängnäs Kommun	9689 (2020) - town 2120/km2 52876 - municipality	24951 (2020) - town 2000/km2 59686 - Gotland
AGE DISTRIBUTION ( <a href="https://citypopulation.de/en/sweden/">https://citypopulation.de/en/sweden/</a> )	0-19y 25% 20-59y 48% 60+ 27% Regularly aged	0-19y 27% 20-59y 54% 60+ 19% Young community	0-19y 20% 20-59y 48% 60+ 32% Old community
MUNICIPALITY - feasibility - needs	Yearly kommun budget for culture: ~60 mln SEK ~1650 SEK / resident ~7 mln / Mariefred	Yearly town's budget for culture: ~137 mln SEK ~14150 SEK / resident	Yearly Gotland budget for culture: ~221 mln SEK ~3700 SEK / resident ~92,5 mln / Visby
RUIN AREA	~ 170 m2	~ 180 m2	~ 330 m2
AREA AROUND THE RUIN	Big - ca 6000 m2 - extension possibility	Big - ca 3000 m2 - extension possibility	Limited - ca 600 m2 - no possible extension (garden)
STRUCTURE	Currently stable, to investigate	Stabilised in 2019, safe to visit	Stable, safe to visit
CURRENT FUNCTION	Weddings, baptisms	None	Weddings, guided tours, performances
DISTANCE TO A RESIDENTIAL AREA - accessibility	500m	500m	0
DISTANCE TO TOWN CENTRE - accessibility	800m	500m	150m
FUNCTIONS IN THE AREA (nearest) - culture - meeting spaces - accessibility - social dynamics	CAFE 900m LIBRARY 900m BOOKSHOP 850m Cinema and cultural activities (small) 500m MUSEUM 500m SCHOOL 500m VIVIANNES small art gallery (private) 900m POM art gallery (for professional artists) 850m	CAFE 400m LIBRARY 100m BOOKSHOP 400m Cinema (small, popular, events every day) 400m MUSEUM 400m SCHOOL 200m Sigtuna Kulturgård art gallery (for professional artists) 500m	CAFE 50m LIBRARY 550m BOOKSHOP 750m; 150m to antiquariat Cinema (two locations) 400m MUSEUM 400m SCHOOL 500m THEATRE 650m Grafikgruppen (courses + exhibitions) 200m STUK - form & konst 400m
LACKING CREATIVE FUNCTIONS	theatre art workshops	theatre art workshops	-
INTEREST IN CULTURE - events - workshop - community engagement	High Cultural events gathering between 10 and 1000 people; art exhibitions almost every week; authors' meetings and interviews; history lectures	Medium ~10 exhibitions yearly, only in autumn and spring; Some social meetings like painting, guitar lessons	High Whole town is focused on culture; Many different cultural locations

Choice of the site for transformation project took several steps and wide research on ruins existing in Nordic countries. One of the requirements was for the object to be located close to the town settlements with easy access, so that the design can serve the local community - the location reachable only by car would be neither profitable for people, nor sustainable considering the transportation. Other preliminary conditions were: the building material, where stone was considered the most durable and resistant, with a good potential of preventing further deterioration after repurposing and no existing cementary around, so that the peace and silence of this type of paces can be preserved. After the preliminary evaluation, three possible sites were taken into consideration.

### 1 / Kärnbo church ruin in Mariefred

Mariefred is a picturesque town in Sweden with ca 4300 inhabitants and a history dating back to the 17th century. It is best known for the well-preserved Gripsholm Castle, built in 1537, and housing a significant collection of art and historical artifacts, as well as its scenic location on Lake Mälaren. Today, Mariefred is a popular tourist destination, offering a glimpse into Sweden's rich cultural and historical heritage.

The town's only church ruin is located near a residential area with some industry objects around. The surroundings include a small forest, residential settlements, golf club, school and grass fields. It is located on a big site of ca 6000 square meters. Nearby there is a very touristic place - the Gripsholm Castle, where approximately 100 000 visitors come each year. Within the 1km radius from the ruin there are cafe's, a library, bookshop, museum, school, cinema organising some cultural activities, but also two small art galleries - Viviannes, which is a private gallery of one artist, and POM, which is a public gallery for professional artists. This town is extremely culture oriented. There are art exhibitions conducted each week; also lots of authors' meetings and lectures are organised and enjoy great popularity. Being such a culture-oriented area, it is a concern that no art workshops for amateurs are organised. The community so invested in various cultural expressions would really benefit from a place that could welcome everyone, despite their abilities and recognition, so that they could create art and culture themselves.



Kärnbo kyrkoruin near Mariefred, Sweden  
Source: <https://tekopptillbergstopp.se/karnbo-sockenkyrkoruin-i-mariefred/> (access: 11/10/2023)

## 2 / Sankt Pers church ruin in Sigtuna

Similarly to Mariefred, in the Stockholm's area there is another small town called Sigtuna, where 3 church ruins are located - Sankt Lars, Sankt Olof (in both locations there are the functioning cemeteries), and the chosen Sankt Pers. The ruin attracts a couple thousand visitors each year. The site is big, measuring around 3000 square meters and in the closest area can be found a small forest, public library, a school, harbour, cafe's, bookshop, Sigtuna museum and a very popular cinema that attracts over 100 visitors daily. 500 metres from the church ruin there is also Sigtuna Kulturgård art gallery, but this place is mostly devoted to professional artists who want to show off and sell their artworks. According to webpage ViaTT, where Sigtuna Municipality posts news articles, in 2019 the Sankt Pers church the Sankt Pers churchruin was stabilised and is now safe to visit. The restoration included hammering iron bars into the walls. The building seems to have a great potential for transformation, as it is now mostly abandoned with only several events being conducted there, for example weddings. There is also mentioned that the investment in church ruins in Sigtuna is a collaborative project between Sigtuna Municipality, Sigtuna Parish, the County Administrative Board in Stockholm and the National Antiquities Office, where the town only needs to cover only around 20% of the transformation costs.



St Per's kyrkoruin in Sigtuna, Sweden. Authorial photography from 24/11/2023.

## 3 / Drottens church ruin in Visby

The last analysed possible site was Drottens church ruin in the Hanseatic City of Visby in Gotland. Visby is the city of history, culture and art. The whole area is a very touristic and cultural oriented location due to being a well-preserved and UNESCO-protected mediaeval town with 19 church ruins and old, over 3km long town wall surrounding the old town. Visby is visited by ca 700 thousand people each year. The small art galleries are popular spots on the town's map and are frequently visited by residents. There are many local artists who have a chance to show their work in public and share inspiration. Regarding the artistic expression place, which is needed in every community for finding release in creativity, BAC -Baltic Art Center works with artistic projects in Visby and whole Gotland, sharing artistic engagement in today's society. However, the institution is focusing mostly on defined artists and designers, not

beginners and amateurs. The site where Drottens is located is very small - around 1000 square meters with 450 taken by the church itself, with no expansion possibility because of the existing surrounding historical sprawl. The closest area is very dense with lots of cafe's and hotels; there can be also found a library, antiquariat bookshop, two small cinemas, a museum, school and a theatre organised in a former church. Within 400m radius from the ruin there are also two art galleries. Both Grafikgruppen and STUK form&konst are places showing art exhibitions as well as organising various courses and workshops. Regarding the cultural aspect, Visby seems to be a well-functioning and complete space for creative expression and gaining knowledge for both inhabitants and tourists.



The King's church ruin.  
Source: <https://www.flickr.com/photos/109551672@N02/37938095212> (access: 13/10/2023)

## / SUMMARY

After taking all the analysed aspects into account, two of the possible sites were rejected.

Firstly, Kärnbo church ruin in Mariefred. The main reason behind the decision was that the town has only one building of this type and cultural value. As the only church ruin in the area, transformation attempt may be too risky and too invasive, as the inhabitants seem to have personal connection to this place, gathering there for weddings and baptisms.

Secondly, Drottens church ruin in Visby. The elimination was a consequence of the town's cultural offer. Visby seems to offer all the possible functions for the residents and visitors to thrive. Even though the places are scattered on the city map, the whole area cooperates efficiently together. Also, the density of Visby's old town and the amount of attractions may result in the new function dissolving among others.

The chosen site is Sankt Pers church ruin in Sigtuna. It is located in a green area being simultaneously located close to residential area and town's meeting locations. The church is one of 3 in the town, which will make the transformation less drastic and allow the community to compare and form their own opinion on the topic of sustainable transformation and repurposing the historical ruins. Municipality of Sigtuna is already involved in taking care of heritage objects and has budget for cultural investments. There is a high potential for the society to draw inspiration from and cherish a new cultural expression spot on the town's map.

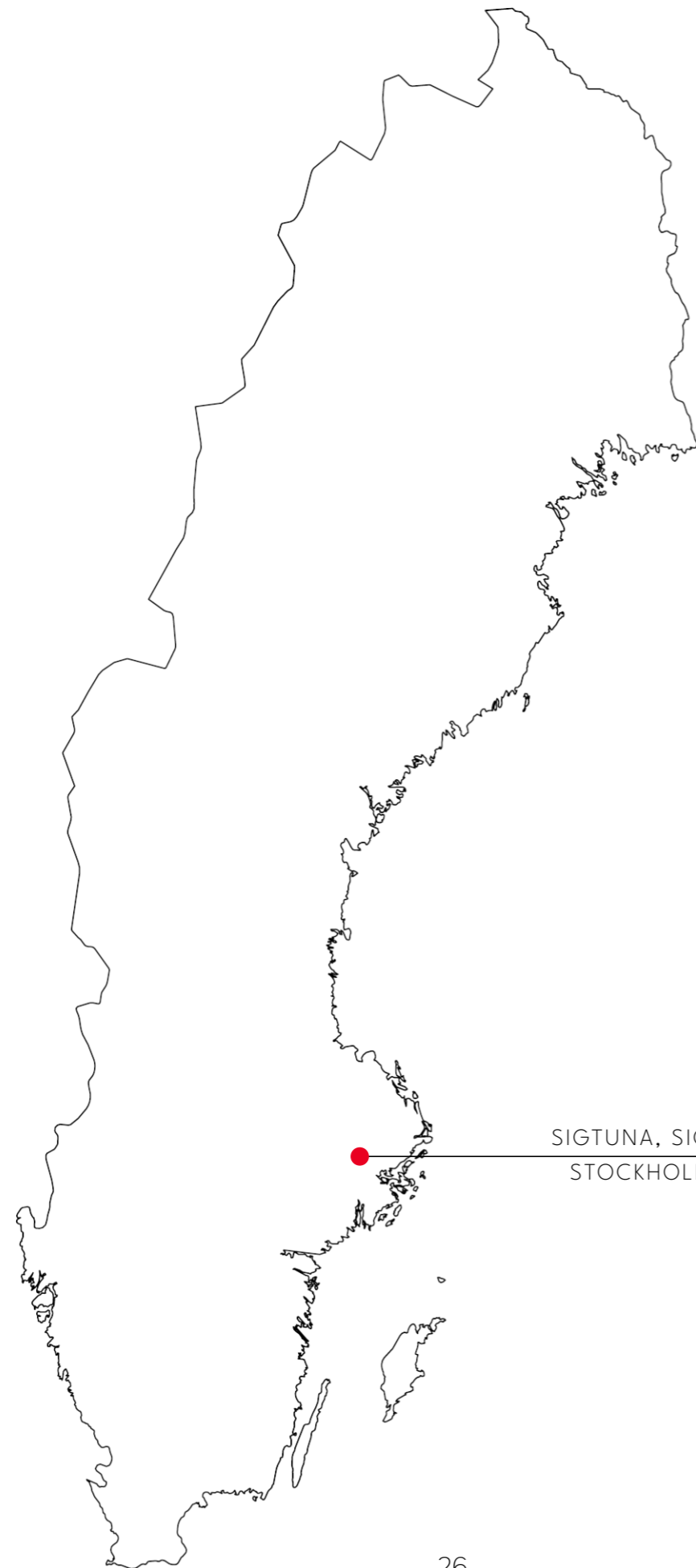

SIGSTUNA, SIGSTUNA MUNICIPALITY,  
STOCKHOLM COUNTY, SWEDEN

## CHOSEN SITE: SANKT PERS CHURCH RUIN IN SIGSTUNA

SIGSTUNA is a harbour town in Sweden of approx. 9500 residents, established around the year 980. It used to be one of the most important cities in Sweden, serving as a royal and commercial centre. Its mediaeval-style town centre offers a wide variety of services - from cafes and restaurants, to museums, cinemas and galleries. In the 19th century Sigstuna's population was only around 600, but started growing after the Stockholm Arlanda Airport gained popularity.

### HISTORY

Sigstuna is the oldest Christian town in Sweden. This history pressures anyone working with it to remember to cherish the existing characteristics and feeling of the place, balancing modern functionality with historical aesthetics and keeping the spirit of nostalgia are crucial.

### LEGAL ASPECTS

Being located in Sweden, any construction or renovation work being conducted on a historical site meets strict EU regulations and guidelines. This is a part of delimitations of this thesis, as those regulations will be taken into account, but probably not obeyed fully.

### SUSTAINABILITY

Integrating sustainable features into a historical structure may require innovative engineering solutions; sustaining the new elements over time and ensuring the ongoing preservation of the historical structure - town involvement; adhering to modern accessibility standards without compromising the ruins' integrity.

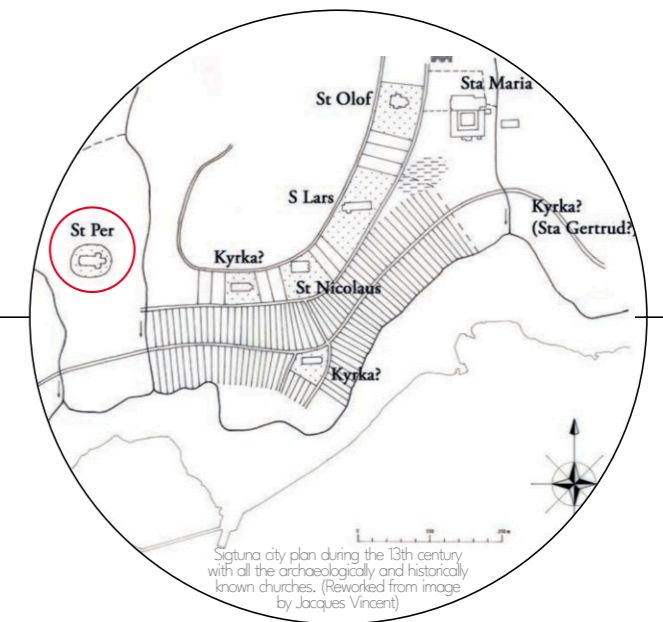

# HISTORY OF SIGTUNA AND ITS CHURCHES - TIMELINE [17]

**late 900s**  
Sigtuna was founded as a Christian town, a religious focal point, where many churches were built during a relatively short period of time.

**980-1050**  
Cemeteries and hall cult

**1050-1100**  
Private wooden churches with cemeteries

**1100-1200**  
Private stone churches in a sacred urban space (6-8st)

**1200s**  
Parish churches and ecclesiastical institutions

**1286**  
Sankt Olofs

**1304**  
Sankt Nicolaus

**1311**  
Sankt Lars

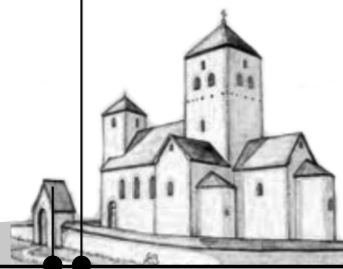

Reconstructed image of St. Per (Image: Jacques Vincent)

Historical map from the 1630s where St. Per is called St. Laurentii (Historical map A88-1; ©Lantmätarset)

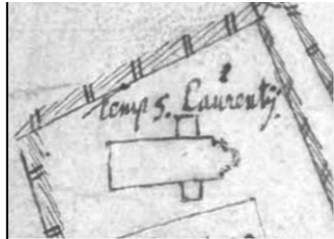

**1612**  
First mention of Sankt Pers as a ruin

**after 1616**  
Mentions of the church slowly collapsing

**1800s**

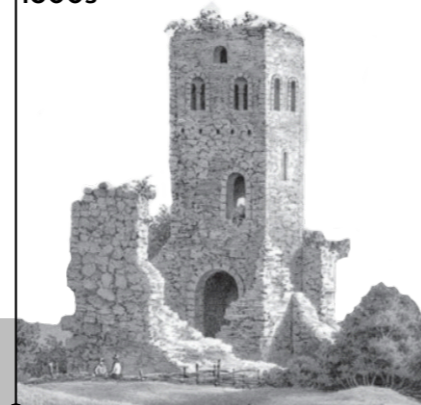

St. Pers ruin late 19th century. Excerpt from a lithograph by I. Hellesen (Sf 2261)

Excerpt from historical map from 1810



*"The church, with its high position and its great towers, must have been awe-inspiring. Now this ancient shrine is a sad ehuru grand ruin, which, deprived of its ring wall, is almost surrounded by frail dwellings and outbuildings, and the sight of the whole is eclipsed by that of the surrounding ugliness." (Brunius, 1851)*

**1220**  
Sankt Pers

- mentioned as a parish church;
- building phase dated between 1080-1230, created under the influence of Anglo-Norman architecture;
- early interpretations as a cathedral, a defense church or king's private church for coronations;
- functioning until ~1529 when Gustav Vasa ordered to abandon it as all parishes in Sigtuna were merged into one

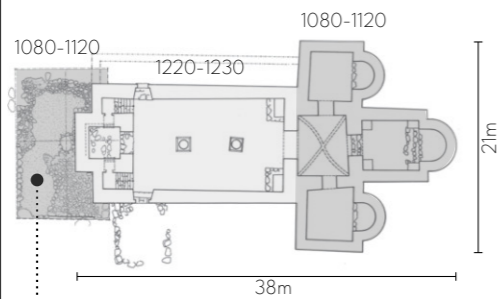

**1934 investigation:**  
a medieval stone building; size 9x14m;  
unfinished expansion of west tower

**1862**

First clearance in history;  
- outer shell collapsed, incl. entrances;  
- wooden beam remains were found  
- heavy fire damage to the masonry - probably because of the fires in 17th-18th centuries  
- 1866 - restoration proposals

**1895**

Restoration:  
- rebuilding parts of the outer shell;  
- repair of the apse vault of N chancel  
- iron bars as reinforcement



The first survey of St. Per by architect A.W. Lundberg, 1862 (ATA Up 1345B)

Church's original appearance according to Eckhoff, 1899. Source: <https://pub.raa.se/dokumentation/aaeca065-be88-4cb4-89cc-ee3a5aa0ea3/original/1> (access: 17/10/2023)

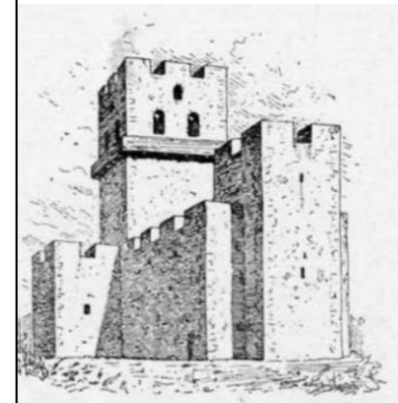

St. Per before Ekhoff's restoration in 1895

**20th century**

Further inspections and restoration works, aimed mostly to keep the ruin in the state from after 1895, took place in 1913, 1946, 1952, 1963, 1970-74, 1991-2.

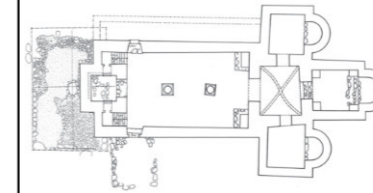

Foundation walls outside St. Pers ruin, in the west foundation of a presumably larger west tower, in the south foundation of an armory, in the north the foundation of a late period house (after RedeliusATA 6786/74 and Floderus1934 Upl392B).

*"Tesch believes that all the churches in Sigtuna have been part of a larger liturgical context where they were tied together with a procession route between the churches"*

Left: plan view reconstruction, 1923;  
Right: roof view reconstruction, 1923;  
Source: <https://pub.raa.se/dokumentation/aaeca065-be88-4cb4-89cc-ee3a5aa0ea3/original/1> (access: 17/10/2023)

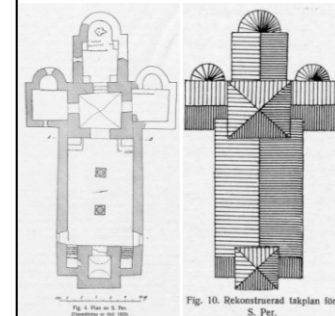

Fig. 10. Rekonstruerad takplan för S. Per.

**2011**

Safety inspection with report

**2015-18**

As part of the "Sigtuna's Church Ruins Preservation and Use" project:  
- extensive deterioration was revealed  
- risk of collapsing was identified (compromised structural integrity)

**2019**

A project including the ruins' stabilisation was conducted. During the process, "2019" has been punched into the iron bars that were hammered in to hold the walls together to stabilise them, as it is important that it is clearly visible what is the addition of our time. Predicted life expectancy of the stabilisation is 100 years.

The Sankt Pers church ruin's tower is a Swedish oldest fortress-like Romanesque tower church. It is an old idea that St. Per played an important role not only as a spiritual place, but also as a fortress or refuge during troubled times. The mighty tower over the center of the cross directly invites such an assumption, but quite naturally every stone building in the Middle Ages has been able to offer some protection against perpetrators of violence.



## 2019'S RENOVATION

In 2019, Bjerking AB <sup>[18]</sup>, on behalf of Sigtuna parish, contributed to the archaeological efforts during the renovation of St Per's church ruins, which commenced in 2015. The restoration aimed to assess damages thoroughly and plan phases accordingly. St Per's church, among Sweden's oldest stone church remains, holds significance for early medieval Christianity and city development. The restoration primarily focused on preserving the ruin's integrity for the future, addressing technical deficiencies without altering its character significantly. These measures were deemed necessary to prevent gradual deterioration and were considered justified without impacting the site's cultural heritage.

The ruin features massive stone walls in shell masonry with mainly chastened stone, occasionally finely hewn, and sandstone details in the central tower's openings. Over time, recurring damage like cracks, shell separations, and missing cement joints occurred due to moisture and vegetation. Restoration efforts date back to the 19th century, including various reinforcements like iron anchoring, injections, and concrete applications. Examination in 2019 confirmed expected damages, with occasional hidden issues. Loose joints were prominent, particularly in intact facades where over 80 percent of the joints were renewed. Extensive rejoining was done inside, especially in the longhouse. Yellowish discoloration from growth on the central tower was effectively removed.

### ACTIONS AND MATERIALS

Various actions were taken to address issues with the wall crown, facades, lime mortar joints, vaults, and wall reinforcements of the ruin. While repairs were initially planned with concrete and lime mortar, a test area showed an overuse of concrete, prompting adjustments to minimize its spread on stone surfaces. Lime mortar joint rejoining continued, with loose joints replaced and a majority renewed internally. Vault treatments deviated from the prescribed plan, opting for asphalt over a proposed bitumen mat for the central tower's vault to avoid potential complications. Reinforcements involved abandoning proposed cintec bars in favor of continuous iron bars for practicality. The design of the anchor irons was simplified to coordinate with previous reinforcements. These actions aimed to preserve the ruin's integrity while minimizing visual alterations and introducing new materials cautiously, ensuring effective execution of the restoration efforts.

The church ruin renovation employed lime alcohol-based algae wash for facade cleaning and a lime and hydraulic Öland lime mortar mix for masonry and grouting. Weber laying mortar C25/30, a cement-based screed, was used for masonry crests and sloping surfaces. Rust protection paint and Alcro Komplet Base and topcoat metal ensured corrosion resistance for steel components. Stainless steel bands anchored corners, secured with threaded rods and Hilti grout. Continuous iron braces with anchor ends were made of acid-resistant stainless steel, embedded in hydraulic lime mortar. Core drilling and stone replacement techniques replaced Cintecstags with stainless threaded rods, concealed with glued-in stones.

### CULTURAL HISTORICAL ASSESSMENT

From a cultural-historical point of view, the care and maintenance work carried out is well adapted to the nature and cultural-historical values of the ruin. Antiquarian considerations have been based on protecting the ruin character of the environment by pursuing adapted interventions that minimize the impact on the visual experience of the ruin as far as possible.



The ruin is explored by two women after the 1890s restoration. The masonry is secured and the central pillars bricked up to an even level. Vegetation still occurs inside the nave. E Eckhoff, 1890s.  
Source: Bjerking AB. (2020, June 23). St Per - restaurering. p.4.



The ruin before the extensive restoration carried out in the 1890s. View from the central tower towards the nave and the west tower. The ruin is nestled in greenery and the central pillar appears to be leaning and missing several stones in the lower parcels. Unknown year.  
Source: Bjerking AB. (2020, June 23). St Per - restaurering. p.4.

## RESIDENTS - SURVEY

Strong opinions of locals need to be taken into consideration. A survey among 60 residents has been carried out in the beginning of 2024. The aim of the survey was to learn the approach of the residents towards the ruins themselves, spending free time, culture and art, but also their needs regarding everyday life.

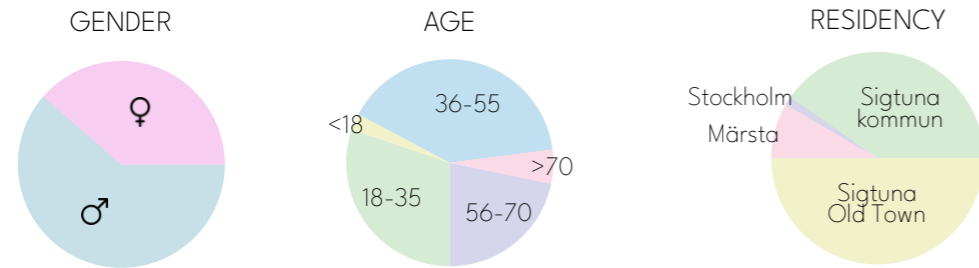

**OPINION ON SIGTUNA'S CHURCH RUINS**

- They are a big part of the local history
- Some of them could be transformed into another, but appropriate function
- There should be no interference with old walls
- They should remain untouched
- They are a great place for walks
- They are forgotten
- Some of them could be transformed into anything that the local society needs
- I am emotionally connected to them
- Some of them could be transformed, but only to a religious function

**APPROACH TOWARDS CULTURAL AND ART EXPRESSION PLACES**

- I sometimes visit those places
- I'm an amateur artist and don't have any public space to work and show my hobby
- I would like to try artistic and cultural activities, but there is no public place to do it
- I know people that would like more of those places
- There is no need for more art or cultural spaces in Sigtuna
- I'm not interested in culture or art
- I would like to explore places like that more

**PLACES IN SIGTUNA VISITED AT LEAST ONCE A MONTH**

- Gröna Ladan bio
- Sigtuna Bibliotek
- Cafe
- Humlegårdens park
- I travel outside Sigtuna for public attractions
- Other places: Sigtuna Kulturgård, Sigtuna museum, kyrkoruiner, Gamla Stan
- Other activities: padel
- I don't visit any of those places at least once a month

**PLACES IN THAT WOULD BE VISITED AT LEAST ONCE A MONTH, IF THEY WERE AVAILABLE**

- Workshop area for various activities (art workshops, social gatherings etc)
- Cafe connected with a library/bookshop
- Art gallery for professional art
- Art gallery for local, amateur art, where everyone can show their work
- Library with local authors' publications, where everyone can show their work
- Shared workspace
- Small arthouse cinema showing local authors' movies
- None of the above

**COMMENTS: OTHER PLACES THAT SHOULD BE AVAILABLE IN SIGTUNA IN CONTEXT OF ART AND CULTURE**

- Exterior art exhibitions accessible 24/7
- A fika place connected to a space for children to express themselves, guided by a teacher - dance, pain, perform - projects to follow
- Outdoor stage
- A new cultural centre merging all generations together
- A program that extends the traditional one but respects the heritage
- Cultural festival in the area of the church ruin
- "Craft house for those of us who don't write but want to paint, work with ceramics and other crafts"

**COMMENTS: OTHER VISIONS FOR A NEW FUNCTION OF A CHURCH RUIN AFTER TRANSFORMATION**

- "Music and theater among the ruins"
- "Training facilities, eg climbing, gym. Theater, art classes, learning activities"
- "Theater venue, museum exhibitions, weddings and funerals"
- "Place where people can take a shelter when the weather is bad"
- "There have previously been concerts here in the summer. Cool if it can become permanent"
- "No, they are newly restored and should be what they are, church ruins"

**COMMENTS: OTHER**

- "I think the ruins should remain untouched but would like to see activity around and in the ruins, buildings in connection with the cafe/restaurant type, gallery at ruins with a lot of 'air' around such as St Per could be nice."
- "I would like to see a historically correctly recreated church ruin as part of Sigtuna's cultural-historical heritage. Let people visit the place as it looked when it was in use and not after its decay."
- "No, I probably only have the above-mentioned suggestions. They are ruins, so it would take a lot of unwanted work to turn them into, for example, an art gallery or something like that."
- "I do not think that the ruin should be converted, but it is already excellent as a stage for smaller concerts of various kinds"
- "Interesting new walkway or path surrounding the church ruin, an interesting promenade of play between the surroundings and the ruin, as this is what is lacking for the ruins in Sigtuna, they are often located in local streets that have the traditional grid system. Better accessibility for people in wheelchair."
- "I think this is a great idea, although sensitive for most Sigtuna residents due to it touching on the traditional which is sacred in Sigtuna. But if done with respect to this and not too invasive, i think it is a great idea to create something new and interesting with the old ruins."



## SURVEY SUMMARY

### STRONG OPINIONS - HOW EXTENSIVE CAN THE INTERVENTION BE?

Churches often hold deep historical and architectural importance, making their ruins valuable assets for creative revitalization. It might include converting the revitalised ruins into unique event venues, community gardens, outdoor theaters, or meditation spaces, so not interfering with the structure.

The design located in a church ruin shall serve a significant purpose, obeying society's needs and opinions. After the intervention, the building volume will serve a new, specific function, while respecting the cultural heritage of St Pers church ruin. The answers to open questions in the survey suggest, that the inhabitants may be scared of destroying the rich history of the place by unnecessary work. Some of them suggested focusing more on the exterior part, meanwhile others were more excited about the proposed interior functions. Many participants expressed their interest in various arts and crafts - both creating them and admiring the outcomes. Others explain, that the cultural offer in general exists in Sigtuna, but may not be enough for everybody's liking. As this thesis is only a speculative proposal and more of an experiment than a plan for future, both parts can be implemented and serve as a base for further research.

As the a project is located in Sigtuna, Sweden, within a mostly secular society, the new function will not include any religious or spiritual function. This approach is also visible in the survey outcome, as only ~10% of people claim that the place should remain religious. After the analysis of the current situation on the global, country and local level, as well as reviewing various case studies and literature positions, the program proposal incorporates compromising the safety of cultural value and the functionality of the new volume.

Taking the survey results into consideration, but also implement a valuable, sustainable architectural design, the proposal will include a mixed-use functions in a small-scale auxiliary building, but also a detailed landscape development around the ruin for public use at all times. Mentioned functions should be supplemented with necessary sanitary facilities and accessibility solutions. In every step of the design process, the concept of saving the irreplaceable spirit of a church ruin should be taken into consideration. The design should accentuate its aesthetical, architectural and cultural value by emphasizing, not obscuring. As a way to cherish the historical value of the site, important elements, such as the rune stone or historical drawings, should be exhibited for public and clearly visible for visitors. Concerning the building volume itself, not only permanent, but also temporary extension elements are taken into consideration.

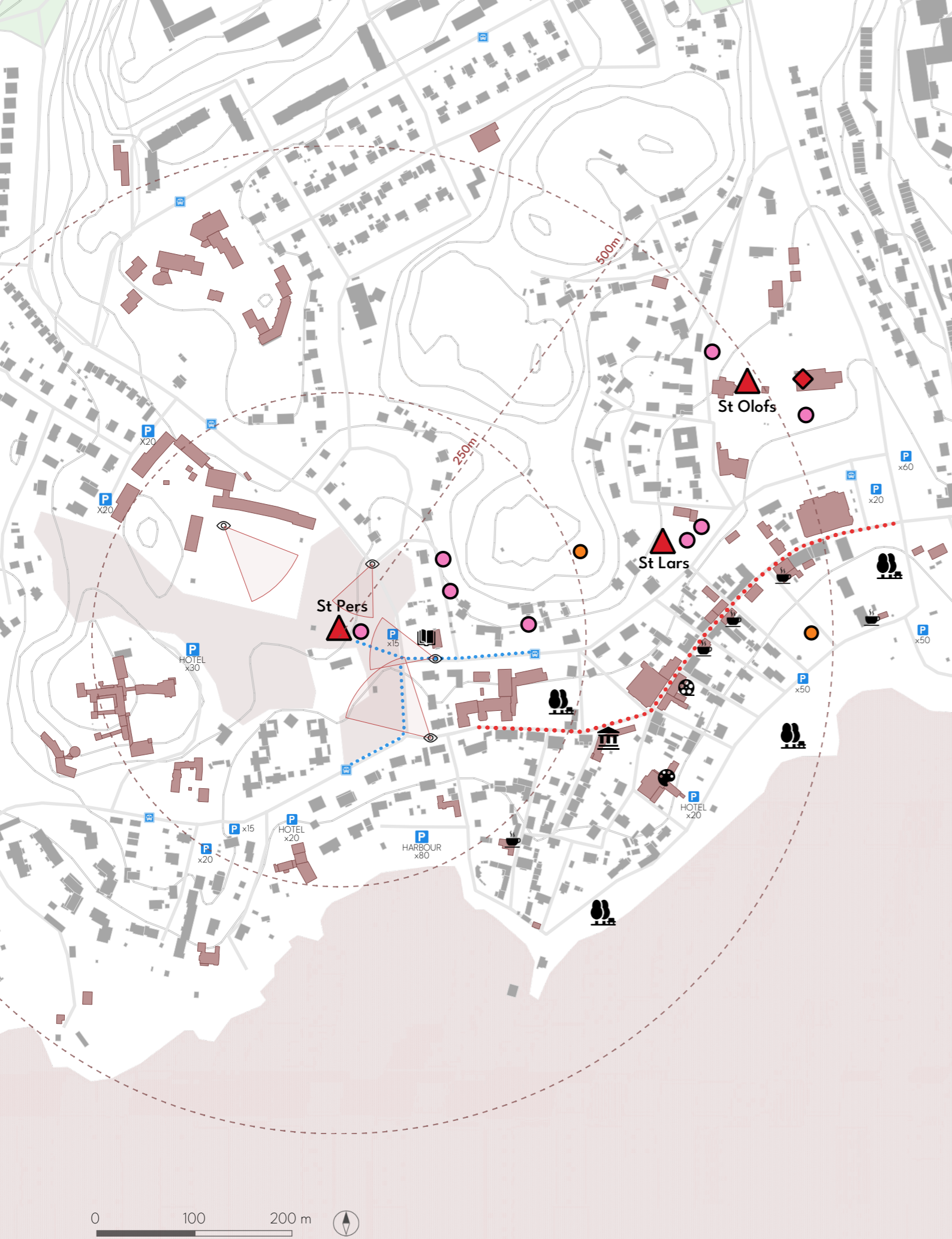

## SITE IN CONTEXT

Sankt Pers church ruin is located on a small hill, relatively close to the most central part of Sigtuna's Old Town. The closest surroundings - within 250m - include greenery and public parks, a library, a school, a hotel and a cafe. Within 500m another functions are visible - a cinema, a museum, art gallery, more cafes, as well as two other church ruins.

Transportation situation is good, considering the size of this town. Main bus stop of Sigtuna is located ca 550m from the site, while two smaller ones are available within 200m reach. Additionally, both private and public parking areas are available - over 250 parking spots between 50m and 600m from the site.

Location on the hill enables the ruin to be visible from various spots around it. It is clearly noticeable from all surrounding streets, from the school terrain and from the library. The whole area is well equipped with pavements for pedestrians to reach all the functions on foot.

It can be noticed that even in the town centre, public and commercial buildings are not the majority of the properties. It is a sign that lots of local residents are actively living in the area and using the facilities on daily basis.

After analysing the site and surroundings, it can be concluded that there is a wide possibility for intervention not only in the closest area of the ruin, but also within the landscape around it. Because of green, open terrains around, there is a chance to create a connection with neighbouring library, but also with Stora Gatan - it is the oldest street in Sigtuna and its most popular part finishes around 200m from the ruin, which allows further continuation of the experience.

There is a visible stripe of public parks extending between Borgmästarängen (most eastern park on the map), along the coastline all the way outside the town. It's a promenade that is intensely used by residents for relaxing walks on regular basis. Sankt Pers church ruin is located 250m from the coastline, which is relatively close to create a connection between the coast park boulevard and the site.

What should be taken into consideration is the accessibility of the intervention, as well as integrity of the historical town tissue and overall current experience of the place, so that any design work will bring only advantages to the area.

- |                                     |                                    |
|-------------------------------------|------------------------------------|
| Ruin                                | Roads                              |
| Functioning church                  | Water                              |
| Object of culture /historical value | Other buildings                    |
| Rune stone                          | Public and commercial buildings    |
| Public park                         | Maximum expansion area of the site |
| Cinema                              | Viewpoints towards the ruin        |
| Library                             | Parking spots                      |
| Cafe                                | Bus stop                           |
| Sigtuna Kulturgård                  | Way from bus stop to the ruin      |
| Sigtuna Museum                      | Stora Gatan                        |

DESIGN PROPOSAL

## LANDSCAPE

The landscape design for the church ruin area incorporates gravel paths that artfully weave through the site, following the natural flow of strollers who currently visit the area. These paths meander around Viking graves and remnants of the church stone walls, with pavements designed to respectfully go around these historically significant features. **Information point platforms**, giving directions and short history insights, are strategically placed at the most valuable viewpoints. Additionally, a **modular wooden platform** is assembled within the ruin for performances, adding a touch of vibrancy to the serene and historic atmosphere.

The **auxiliary building** located on the north side of the site serves as a multifunctional and visitor-centric hub. Including a cafeteria, tourist information point and the historical art wall, it is open and accessible for visitors.

The entire complex is connected with **a terrace** that offers stunning views of the surrounding landscape, creating a cohesive and inviting environment for visitors to explore and enjoy. From the terrace, a mysterious glimpse of the ruin is visible and welcoming to explore the area closer.

The flowy shapes found in the pavements and terraces of church ruins mimic the natural flow of human walking patterns, creating a sense of movement and rhythm that enhances the sensory experience. **These organic and curvilinear forms evoke feelings of grace and fluidity, engaging the visual senses and adding a soft contrast to the rigid structures of the ruins.** In addition to their visual appeal, flowy shapes can also influence touch and proprioception, inviting tactile interaction and encouraging exploration of the space. The psychological impact of these shapes is significant, as they can elicit feelings of calmness, relaxation, and connectedness with the natural world. By incorporating flowy shapes into the design of church ruin surroundings, visitors are immersed in a sensory experience that deepens their connection to the historical and cultural significance of the site.

In addition to the historical and cultural significance, the presence of trees in and around church ruins can significantly impact the acoustics of the site, influencing the perception of the place and human comfort. **Trees act as natural sound absorbers, dampening noise and creating a tranquil ambiance that enhances the overall sensory experience for visitors.** The rustling leaves and bird calls can add a soothing soundtrack to the surroundings, creating a sense of serenity and calmness.

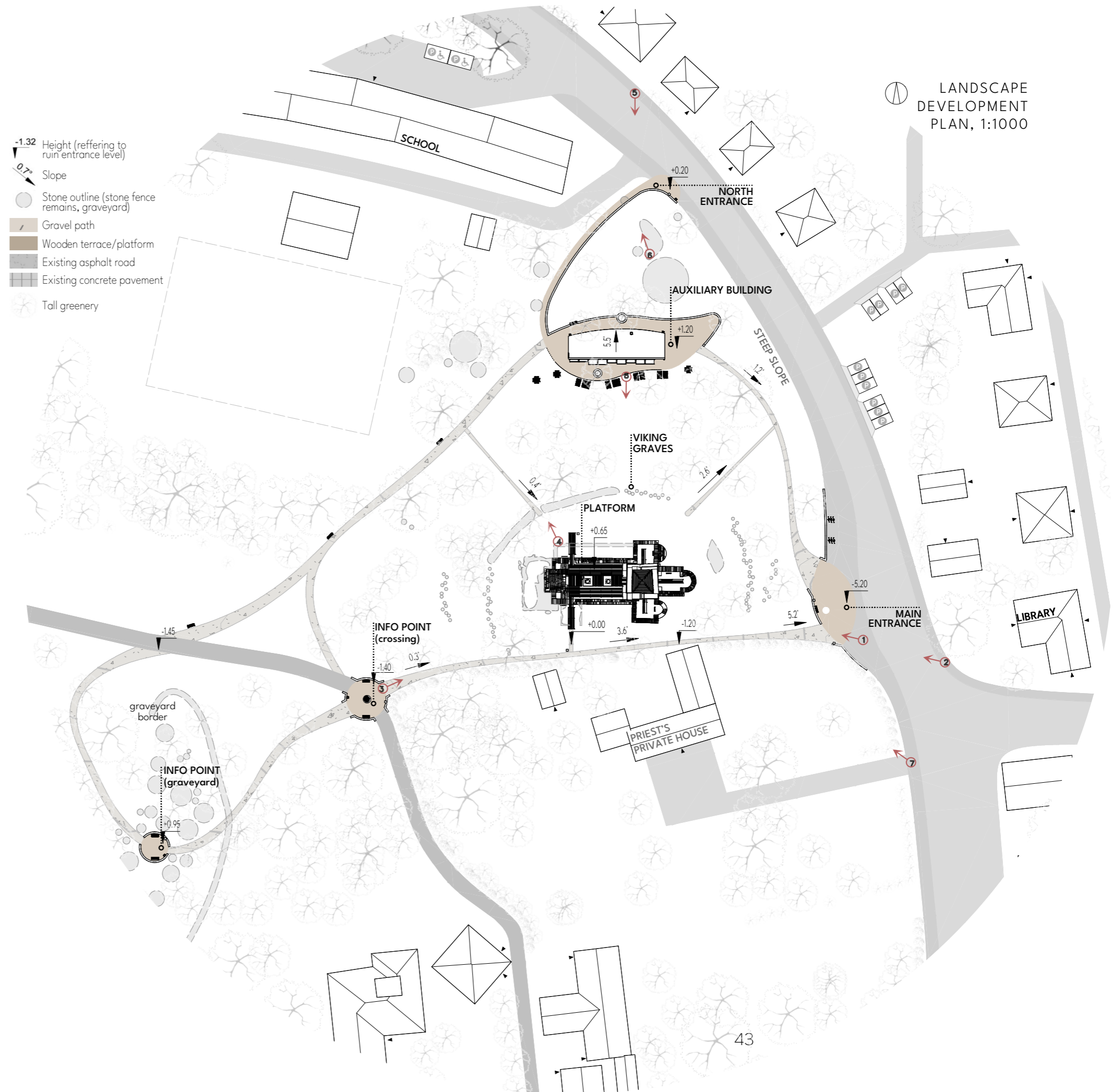



Views from the planned main entrance area towards the

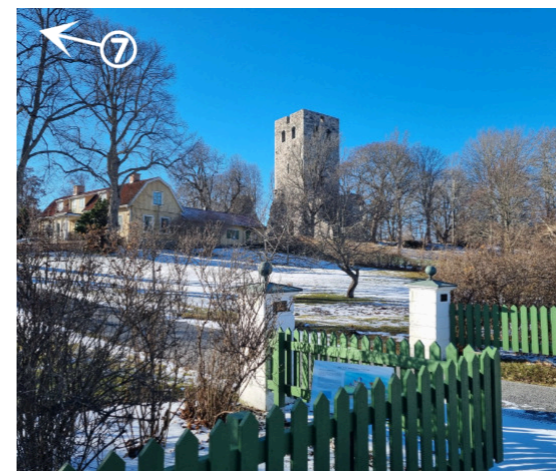

Views from the Priest's house driveway gate



Views from the cafe terrace towards the ruin



Views from the planned western info point



View from the ruin towards the school



Views of the planned northern entrance location





SECTION THROUGH THE WHOLE PLOT NORTH-SOUTH,  
TOWARDS EAST. 1:400

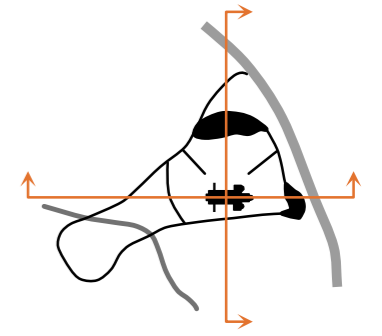

SECTION THROUGH THE RUIN AND WHOLE PLOT EAST-WEST,  
TOWARDS NORTH. 1:400





## PLATFORM

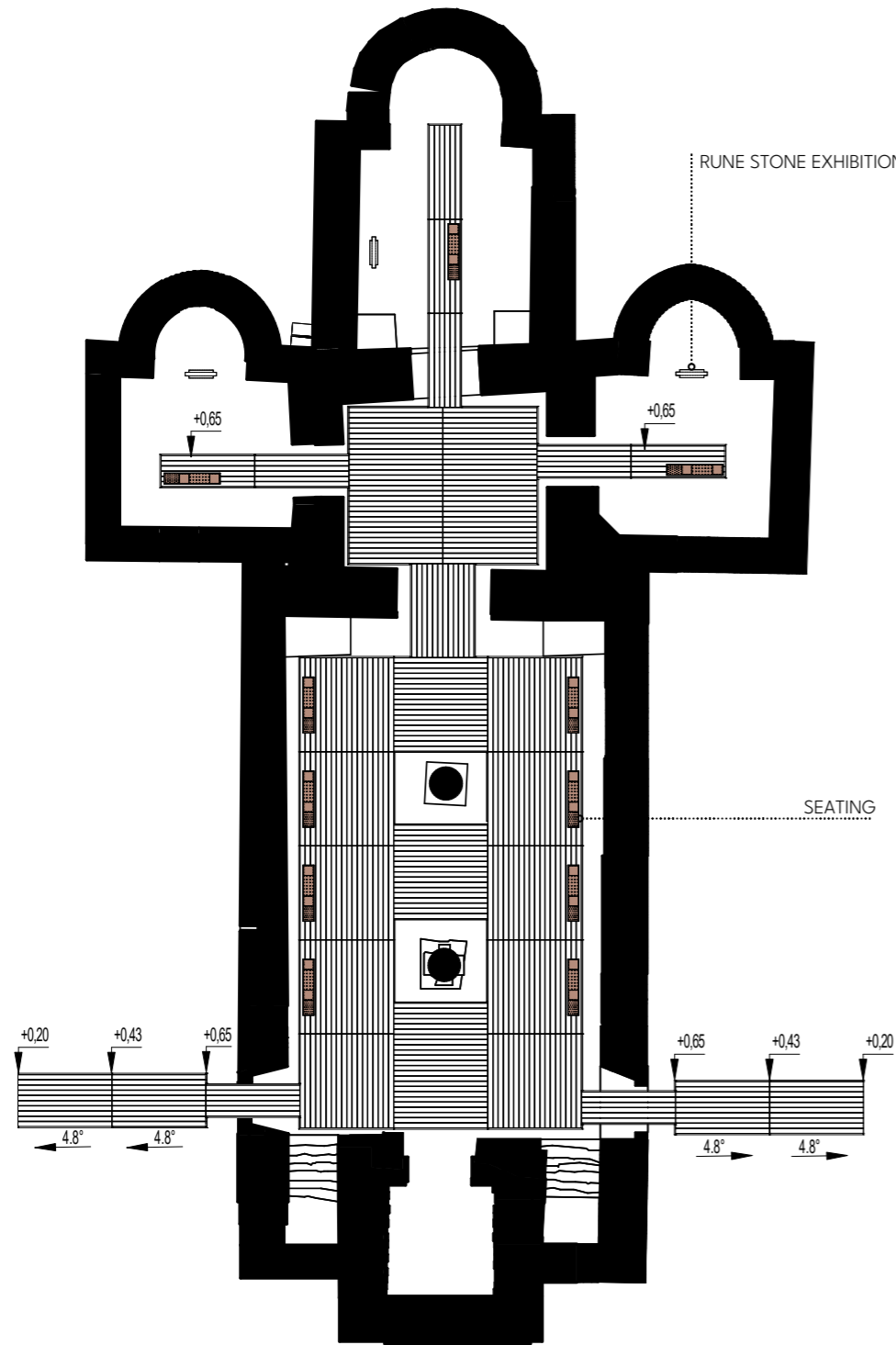

PLATFORM PANELS' LOCATION WITHIN THE RUIN, 1:200

The modular platform within the ruin is an innovative solution that enriches the visitor experience while preserving the historic structure. Constructed from spruce and mounted on height-adjustable brackets, the platform provides a safe and stable performance space, while also preventing further deterioration of the ruin beneath

Notably, the platform can also be disassembled, giving visitors the opportunity to appreciate Sankt Pers in its original state if desired, or if there happens to be the need for renovation work. The platform is designed to be durable and compact, requiring less than 50m<sup>2</sup> of space (see: auxiliary building plan view). It can be easily assembled and stored in a designated area, allowing for a seamless visitor experience. This feature allows for flexibility and adaptability, ensuring that the site remains accessible and enjoyable for visitors.

Importantly, the platform is self-sufficient in terms of construction, as any local wooden workshop can easily assemble it without external assistance. This makes it a sustainable and versatile addition to the site, which can be reused as needed.

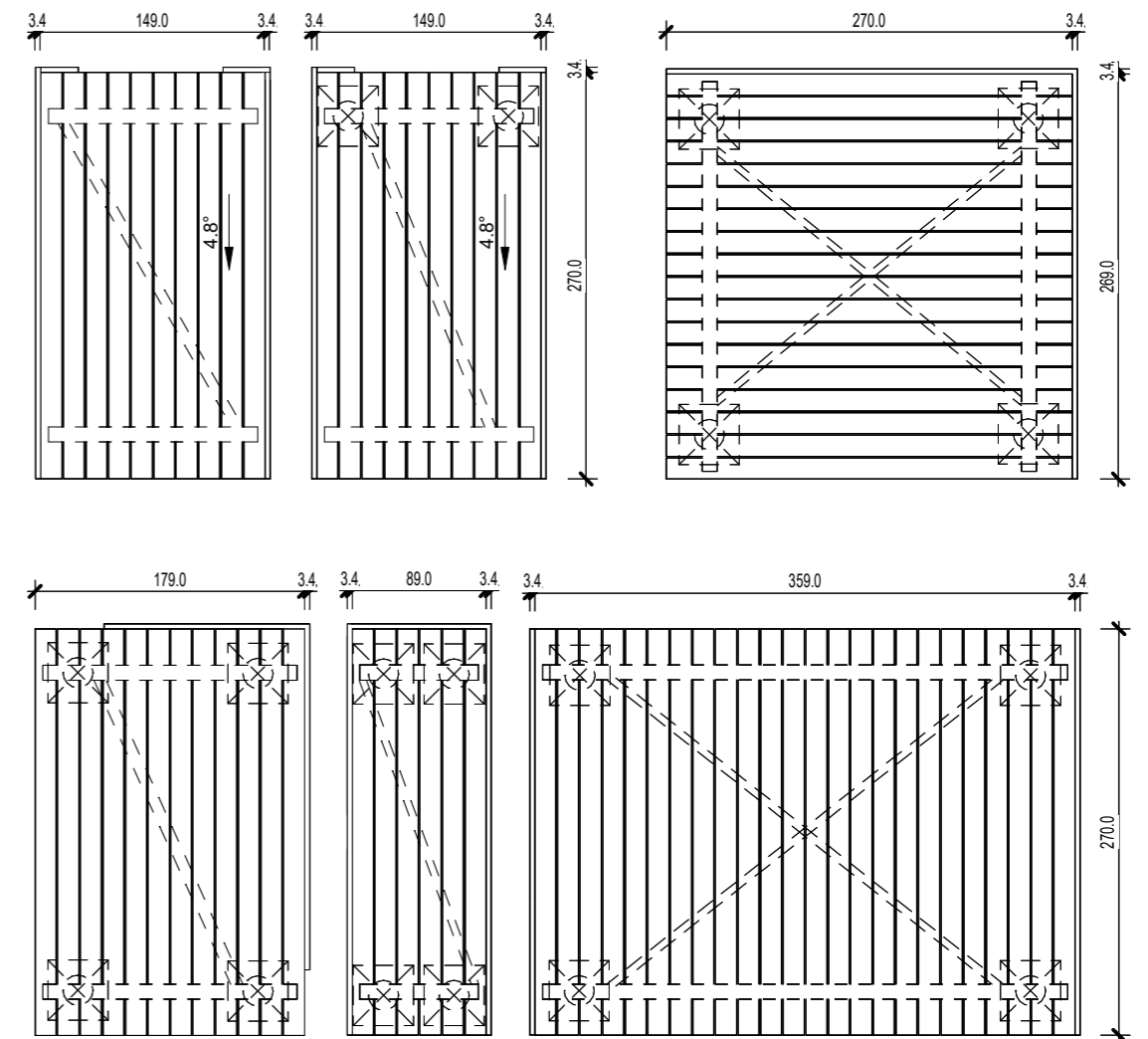

PANEL TYPES' DETAIL - PLAN VIEW, 1:50



SEATING ARRANGEMENT DEPENDING ON MAIN LOCATION  
OF THE PERFORMANCE / EVENT

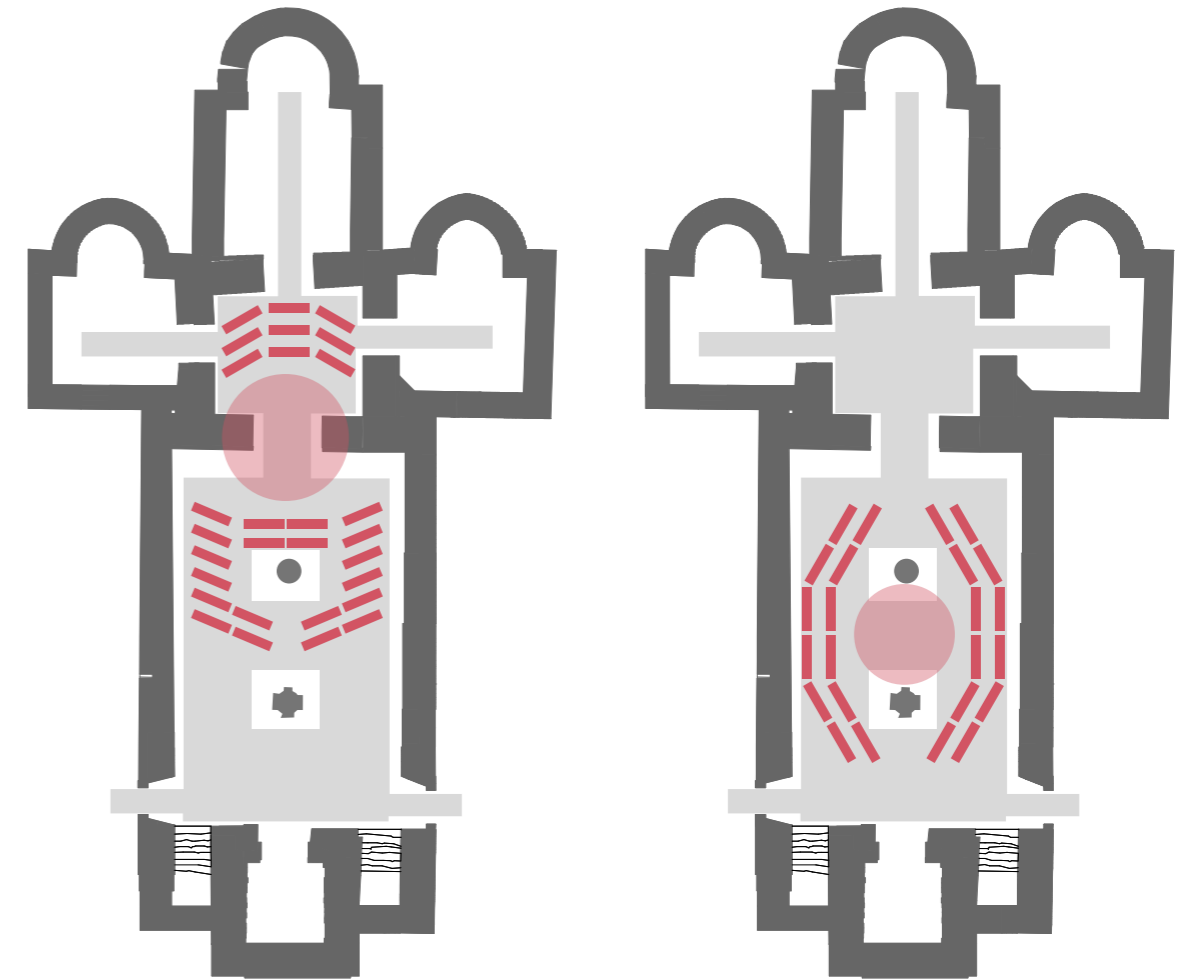

Non-fixed seating solution gives a high flexibility with the layout depending on the specific needs of the users. During a regular day seatings can be arranged along the borders, giving free space in the middle and allowing the bare walls and rune stones to be discovered. During a performance focused in the middle of the ruin, seating can become a theatre around it. In a situation when an event would be held under the tower, visitors can gather in the transept, choir and main nave. The possibilities are flexible and adaptable. When a need of elevating the stage arises, an additional panel without a margin can be safely stacked on top of the basic set.

Determined by the situation, platform can accommodate up to 150 sitting visitors or 50 walking visitors at once.



**TERRACE BRACKET BY DD GROUP EU.  
EXAMPLE PRODUCT SOLUTION.**

Source of the pictures: <https://ddgro.eu/regulowane-wsporniki-pod-legary-tarasowe/>  
(access: 02/05/2024)

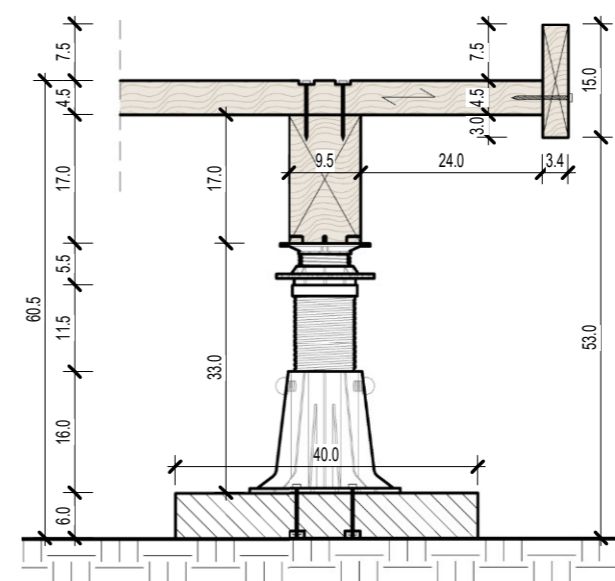
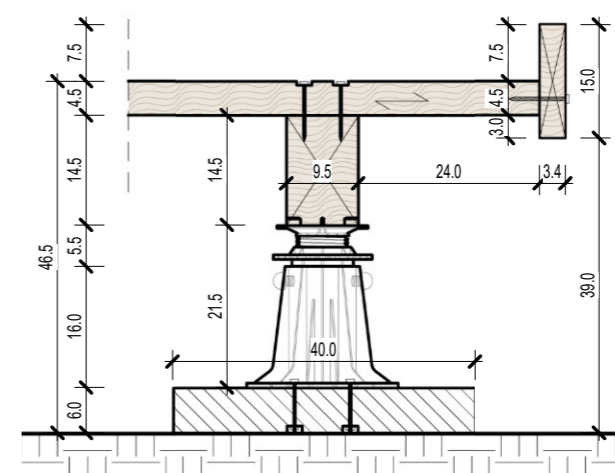
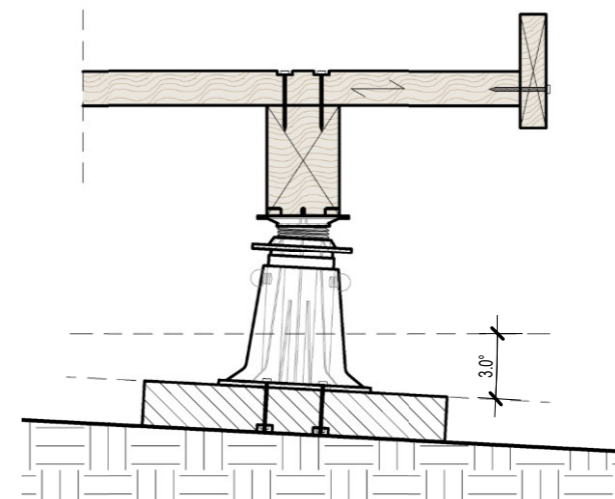

In order to protect the wooden elements of the platforms and terraces against the test of time and harsh weather conditions, the use of linseed oil is used, as a popular solution in Sweden. Derived from flax seeds, linseed oil is a natural treatment that can penetrate deep into the wood fibers, providing protection against moisture, rot, and UV damage. This traditional technique not only helps preserve the wood's longevity but also enhances its natural colors and grain patterns, giving it a beautiful and organic finish. By regularly applying linseed oil to wooden structures such as decks, fences, and furniture, Swedes can maintain their natural beauty without the need for harmful chemicals, reflecting the country's commitment to sustainability and environmental consciousness.

**HEIGHT ADJUSTED  
BRACKETS; DETAIL,  
SCALE 1:10**

Minimum height: 95x145mm beam with 215mm bracket results in total height of 465mm from ground to walking level. Maximum height: 95x170mm beam with 330mm expanded bracket results in total height of 605mm from ground to walking level. The brackets' angle can be adjusted up to 3 degrees.

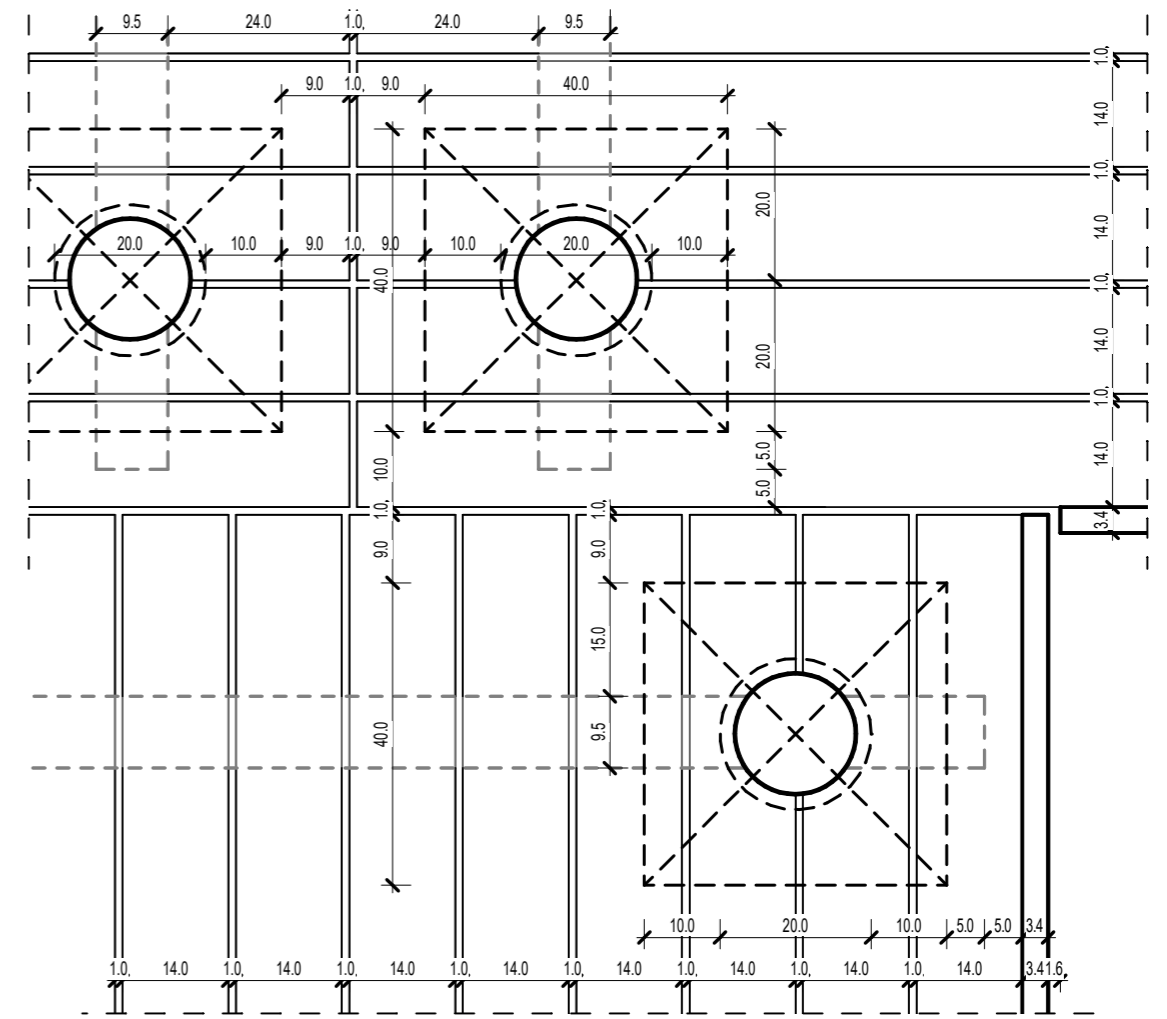

PLATFORM PANELS' ASSEMBLY SYSTEM - PLAN VIEW, 1:10

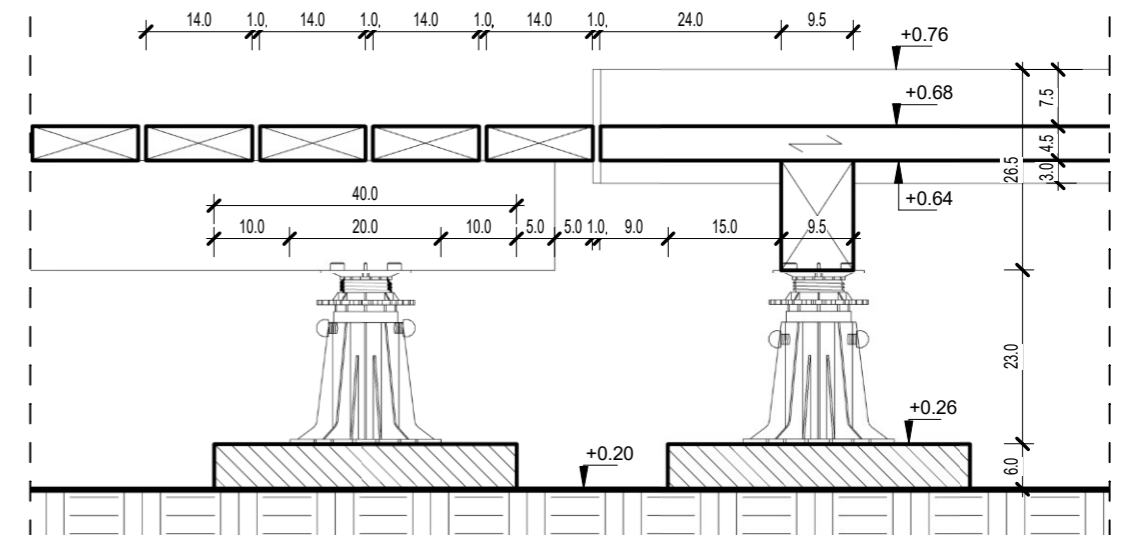

PLATFORM PANELS' ASSEMBLY SYSTEM - SECTION, 1:10

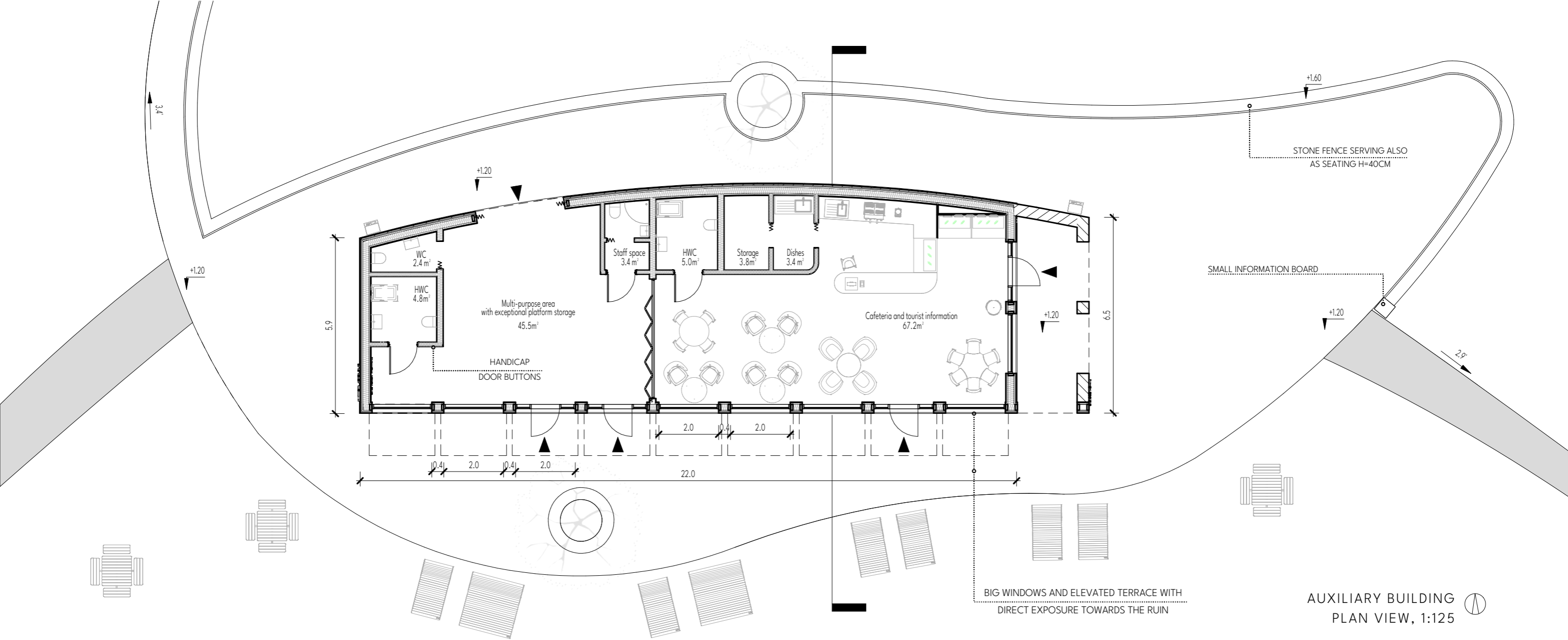

## AUXILIARY BUILDING

Within the auxiliary complex, visitors can find sanitary rooms for their convenience, a cafeteria with a tourist information offering not only fika and refreshments, but also detailed information about the history of the place; a versatile multi-purpose room for various events and activities. The multi-purpose room, neighbouring the cafeteria, is perfect for hosting various events and activities, such as jams, exhibitions, and workshops. The room's flexible layout allows for easy reconfiguration to suit different purposes, ensuring that it can be used for a wide range of purposes. The design of the auxiliary building complements the overall aesthetic and functionality of the landscape, offering visitors a comprehensive and engaging experience at the church ruin site.

The auxiliary building's design ensures that it blends seamlessly into the surrounding landscape, creating a sense of continuity and harmony with the natural environment. The use of locally sourced materials not only reflects the region's cultural heritage but also reduces the environmental impact of the building's construction.

The construction of this building is intentionally designed to align with the most popular construction methods in Sweden, specifically wooden beam construction. This not only allows for local builders to easily construct and maintain the facility but also fosters a sense of community involvement and ownership in the preservation of the historic site.



## CONSTRUCTION LAYERS SOLUTION

### Exterior load-bearing wall:

- horizontal wooden frame 28x45mm with exterior vertical wooden cladding 22mm
- OR steel frame 30mm with stone cladding 50mm
- wind insulation
- vertical beams 45x45mm / wooden fiber insulation 45mm  $\lambda=0,036$
- timber beams 195x45mm / wooden fiber insulation 195mm  $\lambda=0,036$
- vapour insulation
- horizontal beams 70x70mm / wooden fiber insulation 70mm  $\lambda=0,036$
- interior wooden cladding 2x12,5mm
- OR mfp board 15mm nad tiles with cement mortar 25mm (sanitary, maintenance)

### Ground floor on point foundation:

- flooring 25mm
- hydro insulation
- beams 70x95mm / wooden fiber insulation 95mm  $\lambda=0,036$
- timber beams 220x45mm / wooden fiber insulation 220mm  $\lambda=0,036$
- boarding 25mm
- rigid insulation 6mm, sealant
- timber beams frame 170x45mm x2
- capillary break
- reinforced concrete 250x250mm column foundations with footing and steel rebars

### Roof, slope 5,5 deg:

- steel sheet roofing
- bituminous layer
- wood boarding 25mm
- vapour barrier
- timber beams 220x45mm / wooden fiber insulation 220mm  $\lambda=0,036$
- vapour control membrane
- 2 layers of beams 90x45mm / wooden fiber insulation 180mm  $\lambda=0,036$
- interior cladding 2x12,5mm

### Interior walls:

- horizontal wooden frame 22x45mm with wooden cladding 22mm
- timber beams 145/120/90 x45mm / wooden fiber insulation  $\lambda=0,036$
- horizontal wooden frame 22x45mm and interior wooden cladding 22mm

## AUXILIARY BUILDING SECTION WITH VENTILATION SYSTEM DIAGRAM, 1:50

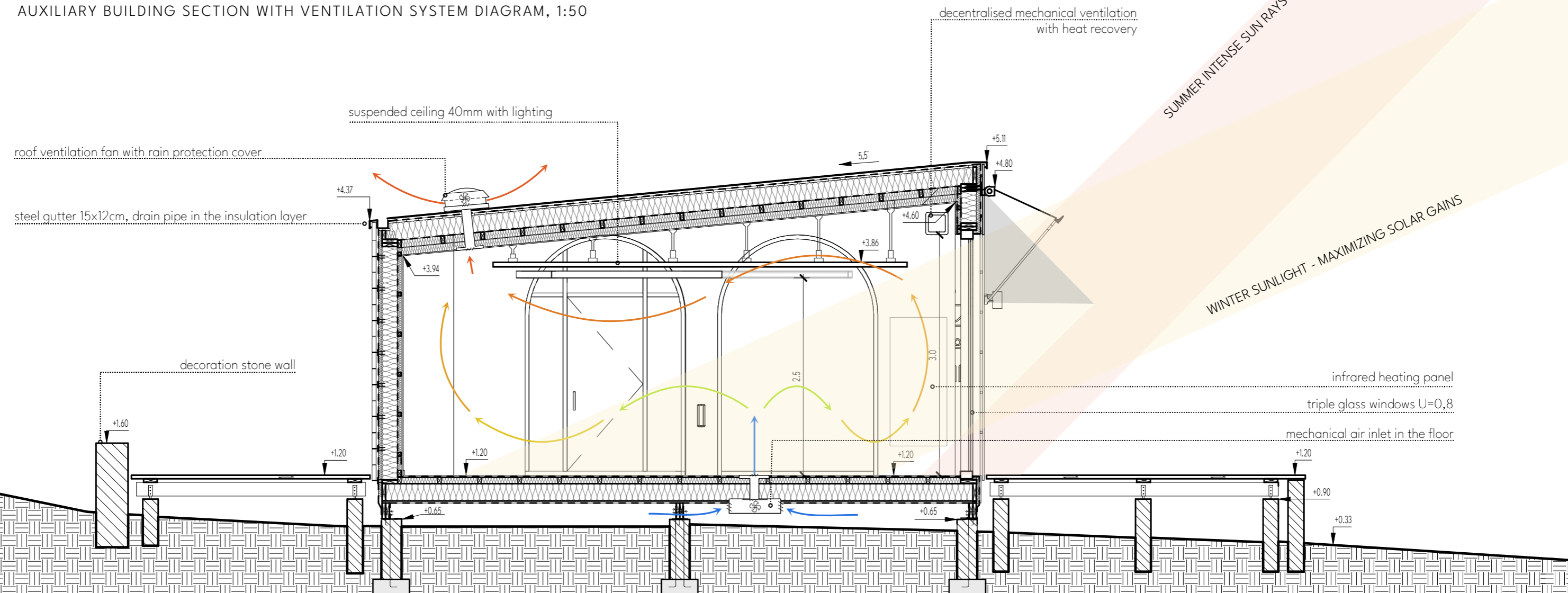





ORIGINAL MATERIALS  
ON SITE

Source of the pictures: Pinterest, textures.com (access: 04/05/2024)



MATERIALS CHOSEN FOR  
THE DESIGN PROPOSAL

Source of the pictures: Pinterest, textures.com (access: 04/05/2024)

## MATERIAL CHOICE

The choice of building materials, such as wood and stone, can profoundly influence how a space is perceived by people and correspond to historical sites like a stone church ruin. These materials carry inherent qualities that resonate with the historical context of such sites and can enhance the historic feeling, knowledge, and experience for visitors.

In the case of a stone church ruin, the use of stone in the construction of surrounding buildings or structures can create a visual connection to the original stone church, while still remaining separate and individual by differentiating the stone type. Stone is a durable and timeless material that has been traditionally used in the construction of churches and historical buildings, symbolizing strength, stability, and longevity. **By incorporating stone elements into the design of new structures near the ruin, it not only harmonizes with the historical aesthetic but also reinforces the historical significance of the site.**

**On the other hand, the introduction of wood as a building material can add warmth, texture, and contrast to the predominantly stone surroundings.** Wood has a natural beauty and warmth that can create a welcoming and inviting atmosphere, enhancing the visitor's experience and creating a sense of harmony with nature. Additionally, wood has historical significance in architectural traditions and craftsmanship, adding layers of cultural richness to the space.

The combination of wood and stone in the architectural context of a stone church ruin can create a sense of timelessness and authenticity, allowing visitors to immerse themselves in the history and heritage of the site. The tactile qualities of these materials, the visual contrast between them, and their historical significance all contribute to enhancing the overall historic feeling and knowledge that visitors experience when exploring the space. By carefully selecting and integrating these building materials, a space that not only respects the historical integrity of the site but also enriches the visitor's understanding and appreciation of its cultural significance can be created.



The design process for the transformative project around the Sankt Pers church ruin in Sigtuna involved a thorough exploration of research, analysis, concept development, prototyping, modeling, design development, and adherence to design principles. Beginning with research and analysis, a detailed site analysis was conducted to gain an understanding of the physical context in which the project would be situated. Program analysis was undertaken to assess the needs and aspirations of future users, and a clear project timeline was developed to ensure efficient management.

In the concept development phase, conceptual diagramming techniques, including sketches, diagrams, and volume studies, were used to refine and shape ideas. Collaboration with fellow students and tutors during brainstorming sessions helped in honing the concept.

Prototyping and modeling were essential in visualizing the design at various scales and stages of the process. Physical models were created to understand the project in three dimensions, while digital modeling techniques, such as Building Information Modeling (BIM), were utilized throughout the thesis.

During design development, materials and details were meticulously chosen based on aesthetics, functionality, and sustainability. Attention to the structural integrity of any remaining ruins was given to ensure safety and stability, seeking collaboration from experts in the field for further design refinement.

Throughout the design process, key design principles were adhered to. Cultural sustainability was highlighted, with an emphasis on community engagement, resource conservation, and the use of environmentally-friendly materials. Accessibility for all users was prioritized, and a functional layout was designed with consideration for user flow and circulation. Aesthetics were carefully tailored to complement the local cultural and historical context, while local regulations were followed, integrating elements that respected the cultural and social context of the project site.

By incorporating these methods and principles, the design project for the Sankt Pers church ruin in Sigtuna was thoughtfully crafted to enhance the historical value of the site and provide a balanced and sustainable space for the local community and visitors to appreciate.

### INTERVENTION APPROACHES by Guidetti and Robiglio

[Guidetti, & Robiglio. (2021, May 18). The Transformative Potential of Ruins: A Tool for a Nonlinear Design Perspective in Adaptive Reuse. MDPI. <https://doi.org/10.3390/su13105660>]

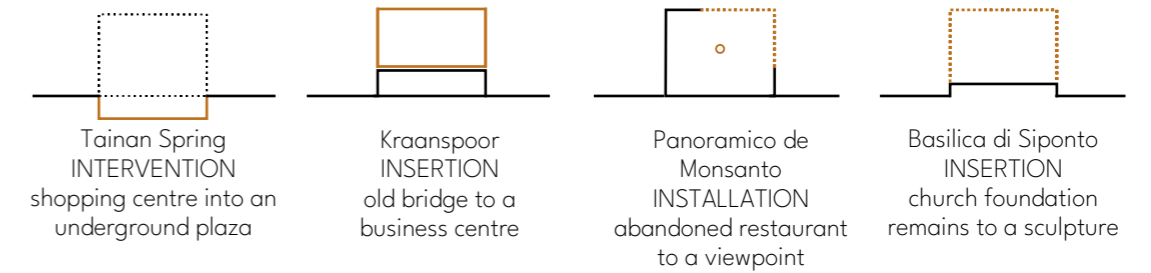

### OTHER TYPES OF INTERVENTIONS

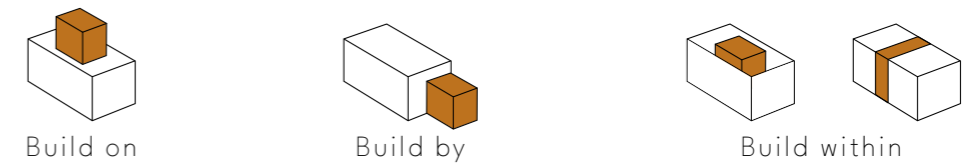

According to Takva, Takva, & Ilerisoy (table 7, p.31)<sup>[19]</sup>, in the transformations the most frequently used materials are steel and glass (88% of the cases). In the middle there is sustainably controversial reinforced concrete (38% of the cases). Wood, copper, composite and ceramic are rarely used (4-8% of the cases). Most of the analysed projects underwent changes to their facade colour and texture, structural material, geometry (shape and plane) and function.

### RESTORATION METHOD PROPOSAL by Camillo Boito

[Boito, C. (2009 [1893]) Restoration in Architecture. First Dialogue. Future Anterior. 61: p. 76]

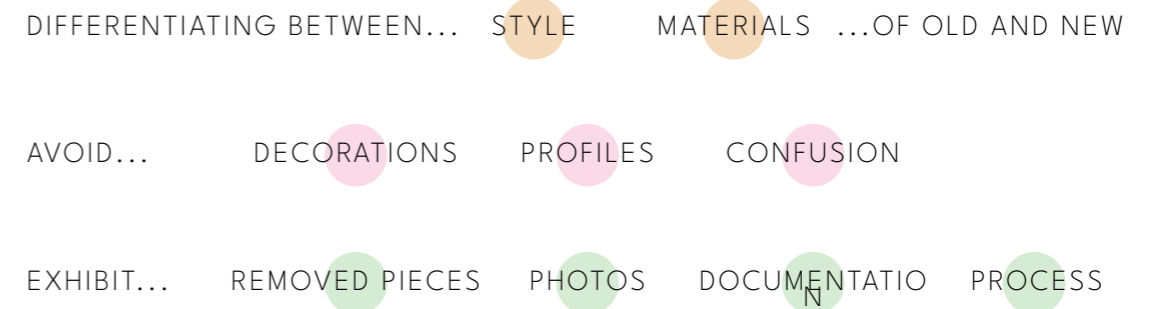

“It is through an understanding and interpretation of the spirit of place and the particular contextual setting within which a building exists that the designer or architect can heighten, change and reactivate a space. An existing structure is bound to its setting; it has certain qualities that are unique only to that particular situation. The designer can analyse and use these found qualities as the starting point or basis for the next layer of construction.”<sup>[20]</sup>

## RESEARCH QUESTIONS

How can the historical value of a church ruin be experienced by adapting and integrating contemporary functions for the local society, while creating a harmony and dialogue between old and new?

Can the history of the place be exposed through new architectural interventions?

Why should the historical value of the place be enhanced?

The design project focused on transforming the area around the Sankt Pers church ruin in Sigtuna has the potential to significantly impact the local community and enhance the historical significance of the site. By incorporating a the platform within the ruins, the project aims to prevent further deterioration of the historical structure while providing a space for cultural activities and performances. Additionally, the construction of an auxiliary building with various amenities like a cafe, multi-purpose room, and tourist information addresses the lack of auxiliary functions in the area and improves the overall visitor experience.

The unique natural surroundings of the site, characterized by an eerie silence and a sense of mystery, are preserved thanks to the deliberate decision to leave the trees and bushes untouched. This subtle yet effective approach allows visitors to step into a time capsule, immersing themselves in the atmosphere of centuries past. The introduction of flowy shapes in the terraces and pavements of the design adds a modern and dynamic element to the historic site. These organic forms create a sense of movement and rhythm that complement the ancient architecture of the church ruin, enhancing the sensory experience and connecting visitors to the site in a more immersive way.

This integration of contemporary design elements not only revitalizes the space but also encourages a dialogue between the old and the new, highlighting the historical significance of the site while adapting it for the needs of the present. The decision to expose the historical value of the church ruin through new architectural interventions and material choices was a step towards creating a harmony between past and present. By carefully selecting materials that complement the existing structure and using innovative design elements, the project succeeds in enhancing the historic feeling and knowledge associated with the site. Visitors are given the opportunity to engage with the history of the place in a more interactive and meaningful way, fostering a deeper connection to the cultural heritage of Sigtuna.

Ultimately, the importance of enhancing the historical value of the Sankt Pers church ruin lies in preserving the rich legacy of the past and creating a sustainable future for the site. By adapting and integrating contemporary functions for the local society, the project not only respects the historical significance of the site but also ensures its continued relevance and accessibility for future generations. Through this thoughtful design approach, the perspective of heritage is transformed, inviting visitors to experience the history of the place in a fresh and engaging manner while celebrating the unique blend of old and new

- [1] Palaghia, T. (2023, May 30). Adaptive reuse of sacred space. RTF | Rethinking the Future. <https://www.re-thinkingthefuture.com/designing-for-typologies/a4034-adaptive-reuse-of-sacred-space/>
- [2] Pappas, J. (1963). Diderot, d'Alembert et l'Encyclopédie. *Diderot Studies*, 4, 191-208. <http://www.jstor.org/stable/40372308>
- [3] De Chateaubriand, F. R., & De Chateaubriand, F. R. V. (1829, January 1). *Génie du christianisme*.
- [4] Simmel, G. (2002, January 1). *La philosophie de l'aventure*. L'Arche éditeur.
- [5] Chateaubriand, *Génie du christianisme*, 40-41; see also Jean-Paul Clément, "Chateaubriand et la fièvre des ruines," *Anabases* 5 (2007): 179-189.
- [6] Operational Guidelines for the Implementation of the World Heritage Convention (Paris: UNESCO, revised 2005) §86. (Paris: UNESCO World Heritage Committee, 1998) §24(b) (I).
- [7] Viollet-le-Duc, E. (1990 [1854]) *The Foundations of Architecture*. Elections from the *Dictionnaire raisonné* (ed. B. Bergdoll 1990 [1854], New York: George Braziller). p. 222-223
- [8] ICOMOS, *The Venice Charter*. International charter for the conservation and restoration of monuments and sites. ICOMOS (1964: Venice).
- [9] Lindblad, & Löfgren. (2016). *Religious buildings in transition*. An international comparison. Retrieved October 11, 2023, from <https://www.frh-europe.org/cms/wp-content/uploads/2020/09/international-report-religious-buildings-in-transition.pdf>
- [10] Morris, W. 'Manifesto of the Society for the Protection of Ancient Buildings, in Price, N., Talley, M. and Vaccaro, A. (eds.) *Historical and Philosophical Issues in the Conservation of Cultural Heritage* (Los Angeles: The Getty Conservation Institute, 1977) p. 319-321.
- [11] CIAM "Statements of the Athens congress, 1933 In A. Van der Woud (ed) *Het Nieuwe Bouwen International*, Housing Townplanning. (Delft: Delfts University Press & Rijksmuseum Kroller-Moller, 1983 [1933]) p. 163-167
- [12] Rem Koolhaas, "Preservation Is Overtaking Us," in *Future Anterior*, Vol. 1, Winter 2004, p.2
- [13] Weeks and Grimmer, p. 61. 64 Douglas, p. 589.
- [14] <http://www.nps.gov/tps/standards/four-treatments.htm> (accessed March 6, 2016).
- [15] Wong, L. (2016). *Adaptive reuse: Extending the lives of buildings*. Birkhauser. <https://doi.org/10.1515/9783038213130>
- [16] The Swedish National Heritage Board. (1988). *Historic Environment Act (1988:950)*. <https://www.raa.se/in-english/cultural-heritage/historic-environment-laws/historic-environment-act-1988950/>
- Case study #1  
I designboom, K. B. (2018, August 14), aleaolea restores spanish gothic ruins of the church of vilanova del la barca Designboom | Architecture & Design Magazine. <https://www.designboom.com/architecture/aleaolea-church-vilanova-de-la-barca-08-14-18/>
- Case study #2  
Thompson, M. (2019, January 28). *Medieval Irish church is reborn as a museum in Kilkenny*. A Medieval Irish Church Is Reborn as a Museum in Kilkenny - the Spaces. <https://thespaces.com/medieval-irish-church-is-reborn-as-a-museum-in-kilkenny/>
- Case study #3  
Sánchez, D. (2021, October 14). *Conservation, Restoration and Adaptation of Church "St. Paraskeva" / Todor Mihaylov, Elitsa Andreeva, Emilia Kaleva*. Aleksandra Vadinska ArchDaily. [https://www.archdaily.com/573012/conservation-restoration-and-adaptation-of-church-st-paraskeva-te-architects?ad\\_medium=gallery](https://www.archdaily.com/573012/conservation-restoration-and-adaptation-of-church-st-paraskeva-te-architects?ad_medium=gallery)
- Case study #4  
Norway, A. (n.d.). *architecture norway | Protective building for Hamar Domkirkeruins*. [https://www.architecturenorway.no/projects/culture/Protective building for Hamar Domkirke ruins 1998/](https://www.architecturenorway.no/projects/culture/Protective%20building%20for%20Hamar%20Domkirke%20ruins%201998/)
- Case study #5  
Sánchez, D. (2019, December 3). *Szatmáry Palace / MARP*. ArchDaily. [https://www.archdaily.com/272346/szatmary-palace-marp?ad\\_medium=gallery](https://www.archdaily.com/272346/szatmary-palace-marp?ad_medium=gallery)
- Case study #6  
Pintos, P. (2022, December 26). *Helfštýn Castle Palace Reconstruction / Atelier-r*. ArchDaily. [https://www.archdaily.com/951016/helfstyn-castle-palace-reconstruction-atelier-r?ad\\_medium=gallery](https://www.archdaily.com/951016/helfstyn-castle-palace-reconstruction-atelier-r?ad_medium=gallery)
- [17] Wikström A. (2020). *Rapport byggnadsarkeologisk sammanställning*. Sigtunas kyrkoruiner. Uppland, Sigtuna socken, S:t Pers ruin RAÄ 22:1, S:t Olofs ruin RAÄ 28:1 och S:t Lars ruin RAÄ 10:1. ISSN 1401-4645
- [18] Bjerking AB. (2020, June 23). *St Per - restaurering*.
- [19] Takva, Takva, & İlerisoy. (2023, April 30). *Sustainable Adaptive Reuse Strategy Evaluation for Cultural Heritage Buildings*. *International Journal of Built Environment and Sustainability*. p. 32, table 8. <https://doi.org/10.11113/ijbes.v10.n2.1060>
- [20] Brooker, G. and Stone, S. (2008) *Context + Environment* (Lausanne: ava publishings sa). P.22

*To my dearest Parents:  
Thank you for your unconditional support,  
which made this journey possible.*

# RESURRECTING HERITAGE

BRINGING NEW SPIRIT INTO A CHURCH RUIN

ZUZANNA MYSZKER  
MASTER'S THESIS 2024



**CHALMERS**  
UNIVERSITY OF TECHNOLOGY

Chalmers School of Architecture  
Department of Architecture and Civil Engineering

Architecture and Planning Beyond Sustainability  
Building Design and Transformation for Sustainability

Examiner: Walter Unterrainer  
Supervisor: Tina Wik

RESURRECTING HERITAGE  
BRINGING NEW SPIRIT INTO A CHURCH RUIN

ZUZANNA MYSZKER  
MASTER'S THESIS 2024



**CHALMERS**  
UNIVERSITY OF TECHNOLOGY

Chalmers School of Architecture  
Department of Architecture and Civil Engineering