

## Resource-Driven Design

Exploring an informed design process in  
the reuse of structural concrete elements

Lina Brülls

Chalmers School of Architecture  
Department of Architecture and Civil Engineering  
Master thesis, spring 2024

Examiner: Paula Femenias  
Supervisor: Peter Elfstrand

ACEX35 Master thesis direction: Building Design and  
Transformation for Sustainability

Thanks to...

Kjartan Gudmundsson, José Hernandez Vargas, Erik Stenberg, and Helena Westerlind for your commitment and patience in guiding me throughout this process and for sharing your expertise.

Bjørn-Tore Johannesen and Kåre Stokholm Poulsgaard for you time and for generously providing me with the necessary prerequisites for this study.

Paula Femenias for your encouragement, support, and guidance.

Peter Elfstrand for the time and energy you put into supervising me and for providing a broad perspective to our discussions.

Astrid Westfelt, Carl Rajala Pettersson, Jasmine Jose, Jessica Börjesson, and Maria Elander for being the most supportive reference group.

Anna Stigenberg for all your support, personal and professional, throughout all these years. You have made this journey so much easier and more enjoyable.

Amaya Steensma Tedder for all the talks, the highs and lows and for always being there.

Anna Högberg, Sara Ekström, Hilma Hultquist and Sys Ahlklo for your support, input and for being there for me on good and bad days.

Mom, dad and Marcus for letting me laugh and cry and talk too much.

...and to all of you who have enriched this journey in all possible ways.



Resource-Driven Design  
Exploring an informed design process in the  
reuse of structural concrete element

Master's Thesis Spring 2024  
Building Design and Transformation  
for Sustainability  
Chalmers School of Architecture  
Department of Architecture and Civil Engineering  
Master's Programme of Architecture and Planning  
Beyond Sustainability

Author: Lina Brülls  
Examiner: Paula Femenias  
Supervisor: Peter Elfstrand

## Abstract

This master's thesis explores the integration of reused structural concrete elements within contemporary architectural practice, focusing on enhancing resource efficiency and reducing the construction industry's environmental impact. Acknowledging the significant contribution of the Architecture, Engineering, and Construction (AEC) industry to global carbon dioxide emissions, with concrete production as an essential factor, this research seeks sustainable alternatives to traditional methods. Specifically, it addresses the potential for reusing entire concrete elements to mitigate environmental impacts.

The study examines the challenges and opportunities of reusing structural concrete elements through a literature review and collaboration with industry stakeholders. It introduces the development of a digital tool, specifically a plugin for Grasshopper in Rhino, designed to streamline the integration of reused elements into architectural designs. This tool hopes to transform the design process by prioritising resource efficiency and incorporating relevant data.

The thesis focuses on the practical application of hollow-core slabs and load-bearing concrete wall elements, investigating their reuse potential. The results are structured into three main parts: an explanation of the Grasshopper tool and its functionalities, the evaluation of data management within the design process, and the implementation of the tool in a local plan in Bergsjön. This involved the creation of load-bearing modules that underpinned the implementations, leading to the development of three architectural projects: a townhouse, a small apartment building, and a larger apartment complex.

Through its findings, the thesis aims to establish a design process that effectively integrates the reuse of structural concrete components. The study underscores the importance of digital tools in enhancing the feasibility of reusing concrete elements and advocates for increased industry standardisation to overcome current technical and regulatory challenges.

## Student Background

**BSc Architecture and Engineering**  
Chalmers University of Technology  
2017-2021

**3XN/GXN Copenhagen**  
Internship  
2021-2022

**MSc Architecture and Planning Beyond Sustainability**  
Chalmers University of Technology  
2022-2024

Studio fall 2022:  
ARK174: Planning and Design for Sustainable Development in a Local Context

Studio spring 2023:  
ARK626: Transformation projects and environmental care

Studio fall 2023:  
ACE475: Material and Technique

Lina Brülls  
+46 (0) 72 746 37 50  
lina.brulls@outlook.com

### Additional relevant courses:

DA204E: Programming in C#  
Malmö University  
Spring 2023

TDA417: Data structures and Algorithms  
Chalmers University of Technology  
Fall 2023

## Content

<b>Introduction</b>	<b>8</b>
<b>Aim and Delimitations</b>	<b>10</b>
<b>Research Questions</b>	<b>11</b>
<b>Method</b>	<b>12</b>
<b>Discourse</b>	<b>14</b>
Building Life Span	15
The CDBE Framework	16
Regulatory Framework	17
Piecewise Reuse	18
Reference Project	20
<b>Context</b>	<b>22</b>
ReCreate	23
Donor Buildings	24
Elements Used	28
Data Template	33
Site for Implementation	34
<b>Analysis &amp; Approach</b>	<b>38</b>
<b>Result</b>	<b>40</b>
Tool	42
Output	44
Data Processing	46
Implementations	48
<b>Discussion</b>	<b>86</b>
<b>References</b>	<b>90</b>

## Introduction

The Architecture, Engineering, and Construction (AEC) industry significantly contributes to environmental concerns due to its substantial resource consumption (Yu, Yazan, Bhochhibhoya, & Volker, 2020). Globally, this industry is responsible for approximately 40% of carbon dioxide emissions (Copeland & Bilec, 2020). Concrete, the predominant construction material since the 1900s, contributes to approximately 8% of global carbon dioxide emissions (Wang, Yan, Fu, & Kasal, 2021). Furthermore, the global production of cement has surged from 1.10 billion tonnes to 3.27 billion tonnes in the past two decades, with projections indicating an increase to 4.83 billion tonnes by 2030 (MVFP, 2013). This upward trend in cement production exacerbates carbon emissions and intensifies the environmental strain associated with primary material extraction.

While the physical lifespan of buildings and building components often exceeds 75 years (Guldager Jensen, Taron, Forward, & Pattullo, 2019), new construction projects, particularly in urban areas, frequently necessitate the demolition of existing buildings (Sigurðardóttir, Heinonen, Ögmundarson, & Árnadóttir, 2023). This demolition process generates vast quantities

of construction and demolition waste, further compounding environmental challenges.

Efforts to curtail construction waste have seen various strategies emerge over the past decade, design for disassembly being one of them (Sommer & Guldager Jensen, 2016). Nevertheless, this strategy primarily emphasises the future reusability of materials and still necessitates the production of new building materials. While we strive for a future where all buildings are designed for disassembly, many existing structures will have already undergone demolition by that time.

An emerging solution is the integration of material databanks into the Building Information Modelling (BIM) design process (Copeland & Bilec, 2020). For instance, a company called Tvinn Solution offers a platform with data compatible with a Revit plug-in (Tvinn Solutions AS, 2023). While this presents a significant step towards reducing construction waste, it primarily focuses on non-structural building elements.

In practice, demolished concrete structures are typically crushed, and the resulting material is often used as aggregates for new concrete production or as subbase material under roads (Udbye Christensen, 2023). This practice initially appears environmentally favourable. However, an investigation published in the Handbook of Recycled Concrete and Demolition Waste (Pacheco-Torgal, Brito, Labrincha, Tam, & Ding, 2013) reveals that considering factors like energy consumption, carbon emissions, eutrophication, acidification, and phosphorylation, there is no significant difference in the environmental impact between Natural Aggregate Concrete (NAC) and Recycled Aggregate Concrete (RCA). NAC even exhibits slightly superior environmental performance (Marinkovic, Ignjatovic, & Radonjanin, 2013).

Reusing concrete elements in new buildings, rather than crushing and recycling, could yield far more significant environmental benefits, thus offering a more sustainable alternative to conventional practices. However, this remains a relatively unexplored and technically challenging practice. Few projects have ventured into this territory due to the technical complexities involved (Udbye Christensen, 2023). Additionally, the industry lacks

comprehensive regulations or certification standards to ensure the quality of reused elements, except for isolated cases, such as a Norwegian standard addressing the reuse of hollow core slabs, which is region-specific.

Although research has been done on the technical part of reusing structural concrete elements, the integration with the design process is still unclear and needs further exploration. We possess limited experience designing with reused materials, indicating the need for enhanced exploration in this domain. Resource efficiency should not only be a consideration but must evolve into a pivotal guiding principle within the design process.

In addressing these challenges, this study seeks to uncover the opportunities and constraints associated with the reuse of structural concrete elements in construction projects and explore the transformation of the design process to prioritise resource efficiency for optimising structural element reuse.

## Aim and Delimitations

The thesis aims to develop a design process that integrates the reuse of structural concrete components into contemporary architectural practices. The research is structured around three principal objectives. The first is to determine the specific data required to reuse structural concrete elements within the design process effectively. This involves an analysis of the information to incorporate reused elements into new projects, thereby making informed decisions that align with aesthetic and structural integrity standards.

The second objective focuses on customising a digital tool for Grasshopper, Rhino. This tool is intended to enhance the design process by providing access to necessary data. The third objective is the practical application and critical evaluation of this tool in a design project incorporating reused concrete elements, assessing its utility and effectiveness in a real-world scenario. This stage is critical for assessing the developed tool's effectiveness, providing a tangible demonstration of the process's applicability and its potential benefits.

The scope of this study is intentionally delimited to hollow core slabs and load-bearing concrete wall elements. By narrowing the research scope to these elements, the study aims to explore

the challenges and opportunities their reuse presents thoroughly. This includes assessing their structural integrity and adaptability to new design contexts. The work in this thesis does not encompass quality testing of concrete elements, structural calculations, or carbon dioxide assessments.

## Research Questions

What data needs to be integrated into what parts of the design process in the reuse of structural concrete elements?

How can a plug-in to Grasshopper, Rhino, be customised to enable data transfer throughout all design stages in a design process with reclaimed structural concrete elements?

How can such a tool be implemented in a case project to optimise the reuse of structural concrete elements while meeting specific program needs?

## Method

Various methods were used to develop the foundation for this thesis. One aspect was assessing practical and feasible data. This was done through a collaboration with GXN, which provided data on the donor buildings used in this thesis and a framework in the form of an Excel template to handle elements data used as a reference in this project.

A collaborative partnership with the research project ReCreate was established. Regular supervision deepened the understanding of the reuse process, the characteristics of reused concrete, potential future applications, and discussions on methodologies and implementations.

A thorough literature review included different aspects of concrete reuse, case studies, structural considerations, and digital tools. The objective was to build a robust theoretical foundation by leveraging existing knowledge in these domains, guiding the research methodology.

The tool's development systematically explored data management within the design process. This involved studying data structures and their practical applications in reusing concrete elements. The focus was on understanding how data flows can streamline the integration

of reuse potentials into the design workflow.

The relationship between building design and structural integrity was examined, along with an investigation of how design choices influence structural considerations and evaluations. The goal was to identify synergies and challenges in incorporating structural assessments into the design workflow.

A reversal of the traditional structural design process occurs when utilising existing stocks of elements, imposing limitations on creating a structural layout — encompassing both geometry and topology — dictated by mechanical and geometric properties (Brütting, Desruelle, Senatore, & Fivet, 2019).

## Discourse

The UN Environment Programme states guidelines for waste management strategies, which go from prevention to disposal, with prevention being the most preferred strategy and disposal being the least preferred (United Nations Environment Programme, 2013). A version of this hierarchy tailored to fit the construction industry contains the following steps: (1) extend the use of structures as long as possible without modification, (2) repair or rehabilitate them if needed, (3) if building removal is unavoidable, deconstruct it and reuse its pieces in another project with minimal reprocessing, (4) if components are not reusable, recycle them into the manufacture of a similar or different product (Hendriks & Janssen, 2003).

As mentioned in the introduction, standard practice for the end-of-life stage of structural concrete elements is to be crushed down and used as aggregate in new concrete (Udbye Christensen, 2023), which, in terms of this hierarchy, is the fourth circular strategy. This method does not significantly impact the reduction of CO2 emissions and mainly reduce landfills (Marinkovic, Ignjatovic, & Radonjanin, 2013).

This study will address situations where the removal of buildings is inevitable, centring on the third circular strategy— i.e., the deconstruction and reuse of its components in another project with minimal reprocessing. Subsequent sections in this chapter will delve into different aspects of this process based on relevant literature studies and project examples.

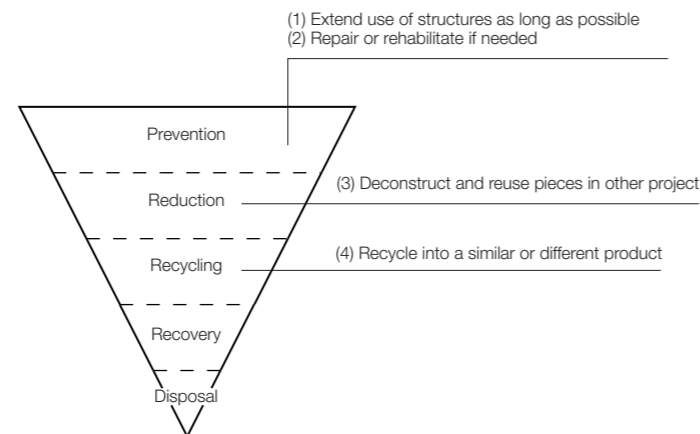

Fig. 1 Waste hierarchy in the BE adapted from the United Nations Environment Program (United Nations Environment Programme, 2013).

### Building Life Span

It is relevant to differentiate between a building's durability and actual life span, as the point at which a building reaches its technical limit (physical life span) often differs from when it loses value due to societal changes (functional life span). The latter is more common and is affected by areas redevelopment and buildings that no longer serve their intended purposes or have undergone neglect. Wooden structures and reinforced concrete buildings are typically assumed to have a lifespan ranging from 50 to 100 years (Ji, Lee, & Yi, 2021). However, an extensive investigation of residential buildings in the United Kingdom showed that 46% of structures that underwent demolition belonged to the 11–32-year class (O'Connor, 2004).

Another study at the Graduate School of Knowledge Service Engineering, KAIST, Republic of Korea, showed that buildings constructed with reinforced concrete in South Korea exhibit an average lifespan of 22.8 years (Ji, Lee, & Yi, 2021). That means reinforced concrete structures in this region are demolished between 27.2 and 77.2 years before their physical life span is estimated to end.

In many cases, building demolition can and should be prevented. However, it is

essential to confront the reality that, in many instances, buildings face demolition, leading to a considerable loss of valuable materials. Building demolition is an intricate aspect of the built environment's life cycle, often prompted by urban development (Sigurðardóttir, Heinonen, Ögmundarson, & Árnadóttir, 2023). This, however, far from diminishing the commitment to prevention, amplifies the urgency of adopting responsible and sustainable measures in the complex reality of building demolition.

### The CDBE Framework

The article "Circular Digital Built Environment: An Emerging Framework" outlines a framework that explores the intersection of Circular Economy (CE), Built Environment (BE), and Digital Technologies (DTs). The framework is rooted in CE principles, emphasising the regeneration, narrowing, slowing, and closing of resource loops, specifically focusing on the role played by digital technologies in facilitating the transition to a circular economy in the built environment. It identifies ten key digital technologies that are pivotal in advancing the built environment's shift towards a circular economy.

These technologies are Additive and Robotic Manufacturing, Artificial Intelligence, Big Data and Analytics, Blockchain Technology, Building Information Modelling, Digital Platforms, Digital Twins, Geographical Information Systems, Material Passports and Databanks, and The Internet of Things.

Reusing concrete building elements falls under the sub-category Reuse within the core principle of slowing the loop. Reuse is defined by (Çetin, Wolf, & Bocken, 2021) as "Bring[ing] resources back into the economy with a minimum of resource input (...)".

When aligning the identified digital strategies

with the circular economy principles, the authors deduced that, within the category of slow strategies, Artificial Intelligence (AI) assumes a pivotal role in sophisticated data-driven regenerative building design. Additionally, for activities in the pre-use phase, Building Information Modelling (BIM) and digital marketplaces were underscored as key components.

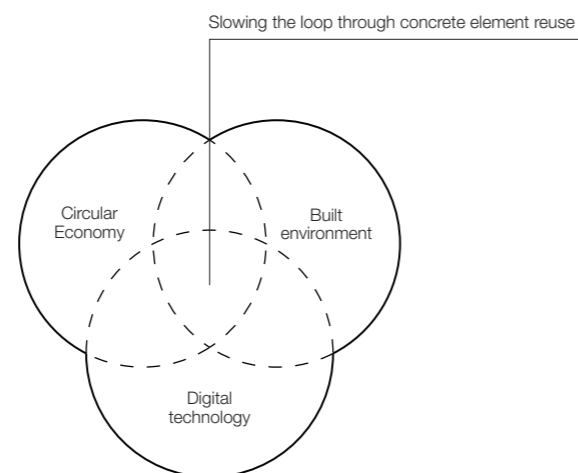

Fig. 2 The intersection of CE, BE, and DT, adapted from Circular Digital Built Environment (Çetin, Wolf, & Bocken, 2021)

### Regulatory Framework

Regulations and frameworks governing the reuse of structural concrete elements are scarce, but the Norwegian Standard for 'Hollow Core Slabs for Reuse' is one of the exceptions. This framework outlines the requirements and guidelines for planning, dismantling, processing, testing, assessment, and documentation of used hollow core slabs to enable their reuse in construction projects. Although it is specific to the Norwegian region and context, it is a valuable reference within this framework.

According to the Norwegian Standard, a crucial first step in the process is to map similar elements, by doing an inventory of hollow core slabs, including those manufactured for specific applications. Additionally, a detailed plan tailored for structural elements earmarked for reuse is required.

The standard highlights the importance of individualised testing methods based on production series. This ensures that all elements are structurally sound and environmentally compatible. According to the standard, visual inspections are crucial to the process, as they help identify visible degradation. Additionally, concrete strength testing is carried out to confirm the suitability of structural elements for future use. A thorough examination of tendons, which are critical for load-bearing capacity, is also conducted (Standard Norge, 2021).

While the nature of this standard is highly technical, its relevance extends to the design process, given the interconnectedness and inseparability of all stages when working with reused elements. Acknowledging the significance of an interdisciplinary workflow is crucial, where architects, engineers, and other stakeholders are well-informed across the process.

### Piecewise Reuse

While the exploration of reusing structural concrete elements is not extensive, it is not unpractised. In this context, it seems suitable to introduce the term Piecewise Reuse of Extracted Concrete in new Structures (PRECS), as stated by K pfer, Bastien-Masse, and Fivet (2022). The term addresses “solutions that require the dismantling of parts to be reused and their subsequent reassembly” (K pfer, Bastien-Masse, & Fivet, 2022, p. 4).

Such a project, called the Udden Project, was done in 1996 in Finsp ng and Link ping, Sweden. Faced with numerous vacant apartments, the decision was made to demolish five multi-family units in Finsp ng. Though built in the '60s, and hence close to being 40 years old, the buildings were in good condition, and it was decided that the material that could be reused would be moved to Link ping, where there was a housing shortage.

With the aim of maximising material and product reuse, the contractor carefully dismantled two buildings in Finsp ng. The primary components of these structures were made of concrete and cast-in-place beams. During the deconstruction process, a diamond saw was used for precision cutting to salvage materials suitable for the new construction. The

deconstruction of about 50 larger apartments resulted in a new building with 22 smaller apartments, totalling an area of 1070 m<sup>2</sup>.

Twelve key actors were directly involved in the deconstruction and construction of the project. Due to expenses surpassing conventional practices by 10–15%, financial support from regional and national agencies was pivotal for the success of these reuse-building initiatives. Managing the spatial planning process for a reused building project within the local authority was a complex task, as highlighted by Eklund et al. (2003). The unique demands of building with reused concrete elements and the challenge of managing timing added to the complexity (Eklund, Dahlgren, Dagersten, & Sundbaum, 2003).

There are no reported technical issues in the gathered records, affirming the technical viability of reusing cast-in-place concrete elements for multi-housing buildings. An environmental analysis indicates that in this scenario, the reuse of components resulted in a 60% reduction in CO<sub>2</sub> emissions and a 40% decrease in energy consumption compared to a comparable building constructed with new concrete (K pfer, Bastien-Masse, & Fivet, 2022).

Fig. 3 Assembly of new building in Link ping. Image source: (Eklund, Dahlgren, Dagersten, & Sundbaum, 2003)



### Reference Project

An ongoing initiative to reuse structural components is the Återhus project, derived from the Swedish Government's "Handlingsplan för omställning av Sverige", which highlights the construction and real estate sectors as significant contributors to resource consumption. The project finished its second step, "Utmaningsdriven Innovation Steg 2," in late January 2023. It consists of eight work packages, covering everything from analysing and developing circular economy strategies to technical challenges, regulations, and design processes.

Work Package 5, particularly relevant for this thesis, addresses the area of design with and for reuse, discussing the potential to scale up and streamline the reuse process. It highlights the necessity of establishing marketplaces for structural building components as a critical part of this scaling process. A key finding relevant to this project is that heavy building components, such as hollow-core slabs, can be successfully reused. It is emphasised that the early involvement of all stakeholders is essential to identify the opportunities these materials present for new constructions. The recommendations for the next steps in developing this scale-up include exploring architectural and technical solutions for

concrete and timber hybrids. Additionally, there is a need for enhanced digital modelling methods throughout the building's life cycle to document the elements effectively throughout their lifespan (Codesign, Contiga, NCC, Ramboll, RISE, Stockholms stad, KTH, Zengun, Fabege, Vasakronan, 2023).

Fig. 4 LCA diagram. Adapted from Återhus. (Codesign, Contiga, NCC, Ramboll, RISE, Stockholms stad, KTH, Zengun, Fabege, Vasakronan, 2023)

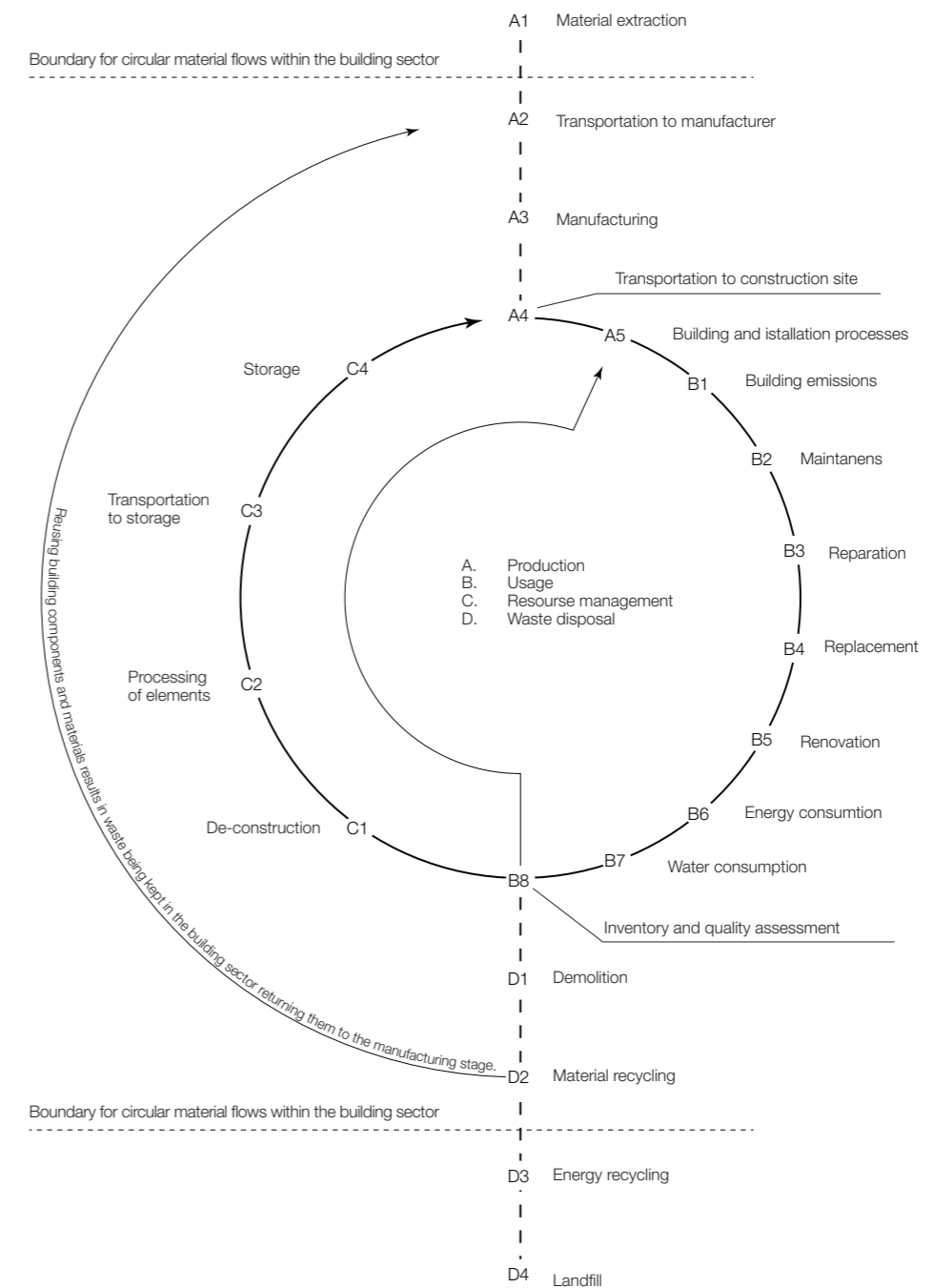

## Context

The context for this project is predicated on the current lack of material banks, necessitating the identification of one or more donor buildings for each reuse project. The project operates under the premise that the demolition of buildings results in material waste, which often remains underutilised or is downcycled. The decision to demolish or preserve buildings is inherently complex and highly politicised, meriting a nuanced discussion beyond this thesis's scope. However, it should be made clear that while exploring the potential of materials left over from deconstructions, this thesis does not endorse demolition but advocates for thoroughly analysing each building's condition, considering social, economic, and environmental factors and prioritising prevention.

With this being said, it is not unlikely that resource relocation will become increasingly common due to the escalating scarcity of virgin materials. This potential trend implies that existing resources will gain more value as obtaining new materials becomes more challenging.

The concrete elements used in this thesis stem from the Danish government's approach to urban redevelopment. Their initiative, "Ét Danmark uden Parallelsamfund," seeks to

dismantle physical and social segregation within Danish cities by demolishing or repurposing 40% of the housing stock in designated areas. The buildings targeted in this initiative are primarily public housing units (Heunicke, et al., 2020).

Due to this, several structural components of these buildings will be or have already been disassembled, creating a temporary material bank. These elements are currently under investigation to determine the most effective methods for handling and reuse. This focus is driven by the available data on these components, enriched through an ongoing research project called (P)RECAST. Consequently, collaborating with GXN Innovation, a participant in this research project, has been a strategic choice for working with these building elements.

While various structures, such as old industrial buildings and parking garages, are being demolished, the choice to work with these elements was driven by the accessibility of existing data. This choice was made despite the highly politicised nature of the debate surrounding these demolitions.

The need to collect data independently for other types of buildings would have constituted a project which would not have allowed sufficient time to explore the intended research questions within the scope of this work. Therefore, this study has concentrated on hollow-core slabs and wall elements, the main components of the buildings currently being dismantled. However, it acknowledges the significant potential for investigating the reuse of other types of concrete elements, such as TT beams or columns, which could provide further insights into reuse practices.



Fig. 5 Dismantling of HC element. Image source: GXN

### ReCreate

A central part of the context of this thesis is the collaboration with the ReCreate project, a research initiative funded under the European Union's Horizon 2020 program that focuses on the reuse of precast concrete elements. The project spans from 2021 to 2025 and involves key academic and industry partners across Finland, Sweden, the Netherlands, and Germany. The Croatia Green Building Council serves as the communications partner.

The primary goal of ReCreate is to change how concrete is utilised in construction by promoting the deconstruction and subsequent reuse of precast structural components. This approach aligns with the EU Waste Hierarchy and the EU Construction and Demolition Waste (C&DW) Management Protocol, prioritising dismantling and reusing materials over recycling. By doing so, the project aims to close the loop for concrete utilisation at its highest possible level.

The project's activities are organised into ten work packages, each addressing different aspects of the initiative. They include collecting detailed information on precast systems, pre-pilot lab-environment prototypes, and real-life demonstrations in each participating country cluster. Environmental, business-related, legal and social impacts are considered and evaluated, ensuring that project findings and advancements are shared widely within the consortium and across the broader construction and demolition industries (Pakarinen & Huuhka, 2021).

### Donor Buildings

The donor buildings are part of the Gellerupplanen in Greater Aarhus, completed in 1976. The project addressed the post-war housing shortage by integrating systems thinking and industrialisation to the new urban district. Beyond just providing housing, Gellerup was designed to be a self-contained community with shopping centres, schools, and other communal spaces.

The buildings were constructed with load-bearing walls, prefabricated concrete units, and hollow core slabs that feature longitudinal voids. These slabs enabled longer spans and quicker assembly, aligning with the project's industrialised construction methods (Gudmand-Høyer, et al., 2021).

GXN has inventoried the buildings slated for deconstruction, forming the foundation of data used in this thesis. The site plan marks three buildings from which the elements used in this work are sourced. These buildings comprise more elements than are manageable within the scope of this thesis; therefore, only one type of hollow-core slab and one type of wall element are utilised. These elements are discussed in detail in the following section of this chapter.

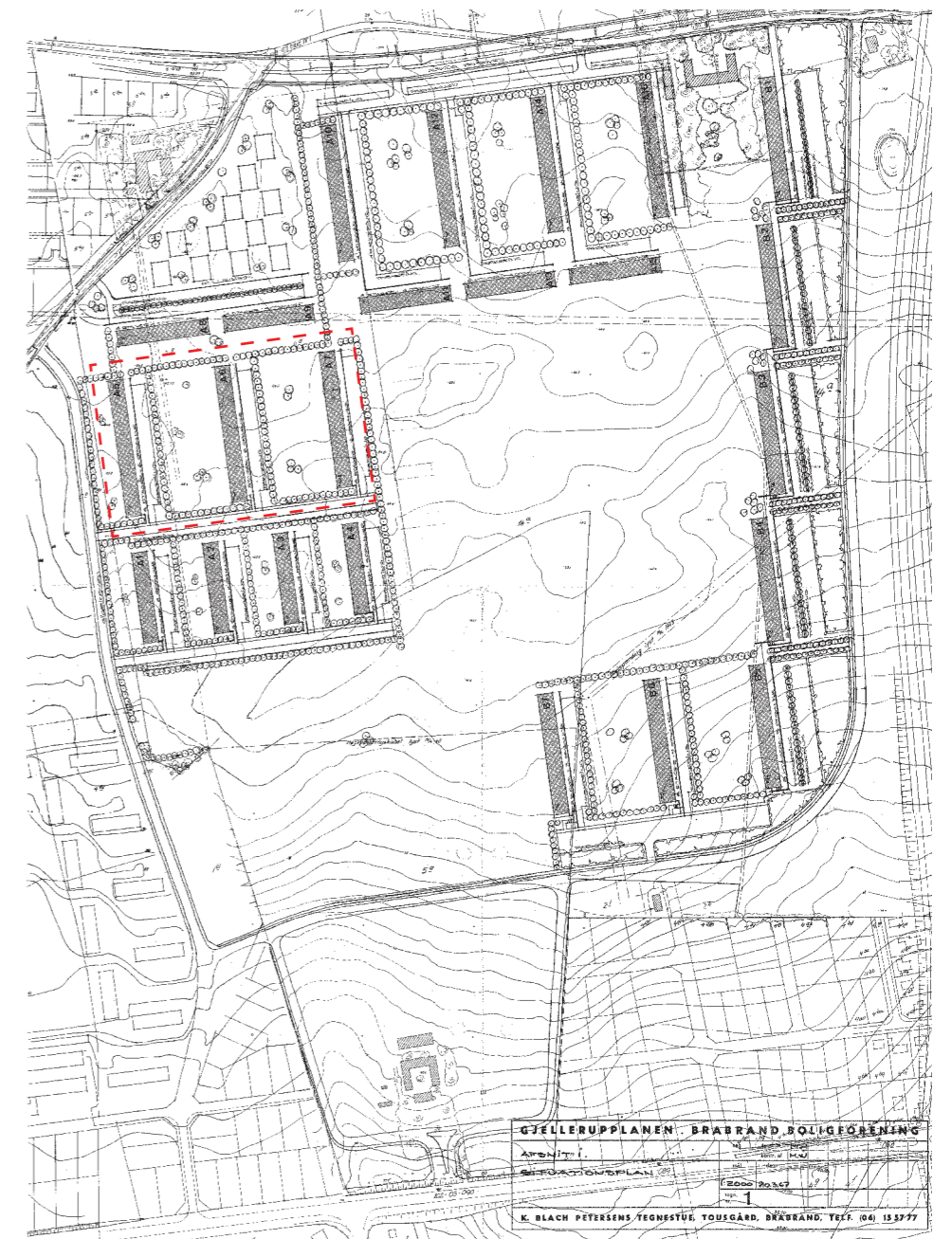
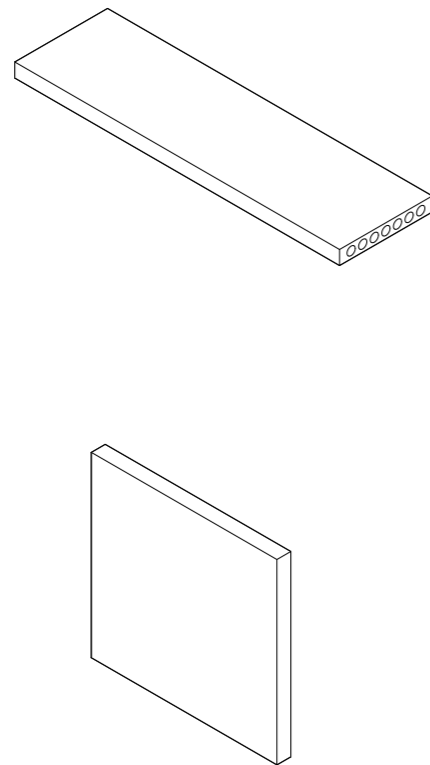

Fig. 6 Site plan of Gellerup. Buildings used in this thesis are marked in red. Image Source: Århus Kommunes Ejendomsarkiv



### Elements Used

The elements employed in this thesis consist of hollow-core slabs measuring 1200 mm by 180 mm by 4200 mm and load-bearing wall elements measuring 2400 mm by 150 mm by 2300 mm. Each building incorporates 336 such hollow-core slabs and 528 wall elements of the aforementioned dimensions. Across all three buildings, there are a total of 1008 hollow-core slab elements and 1584 wall elements with these specified dimensions.



*Fig. 8 Axonometric drawing of concrete elements. Own illustration.*

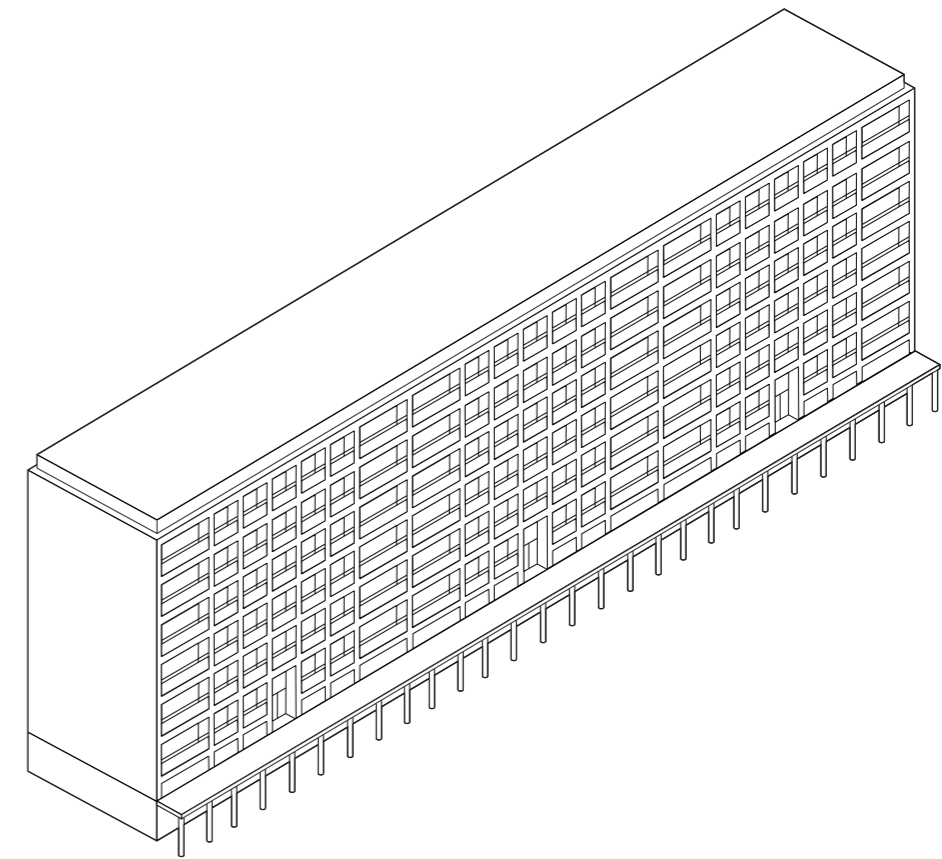
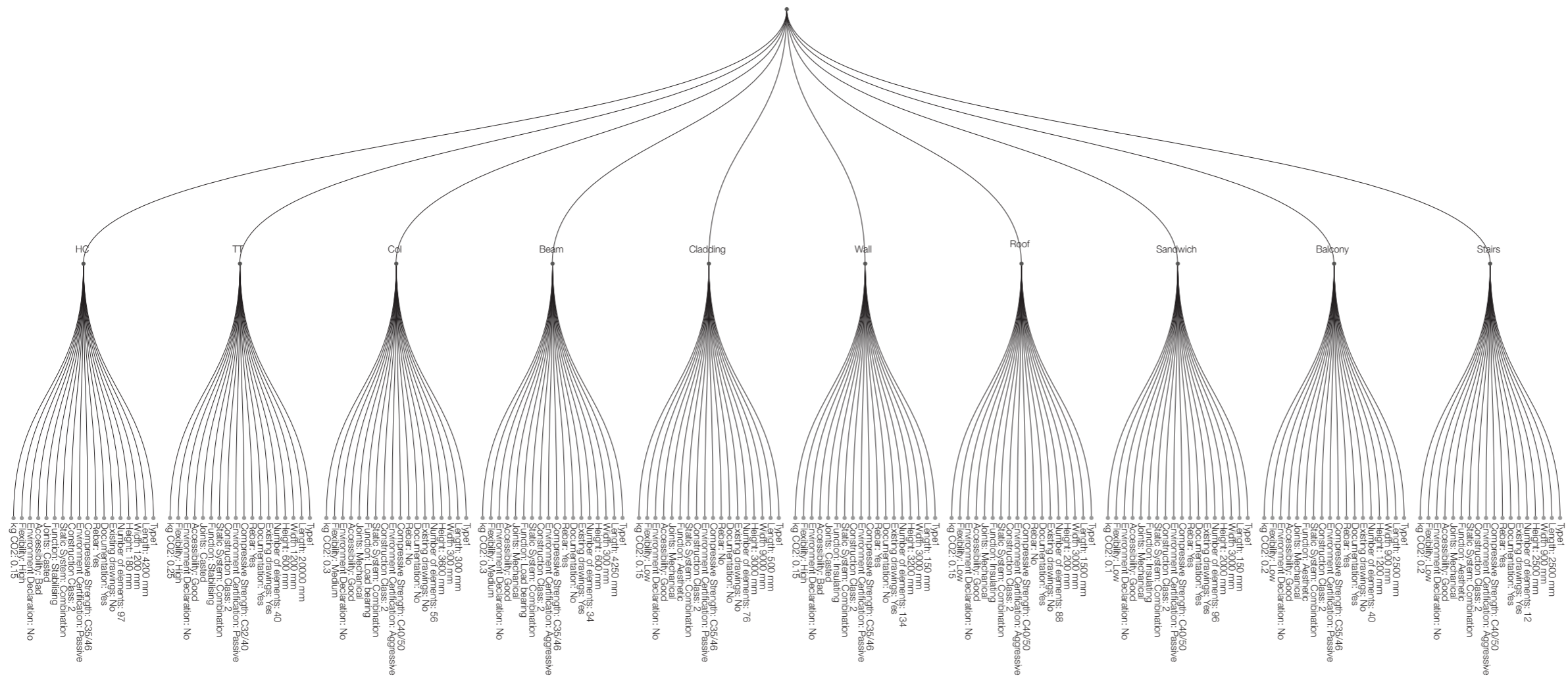

*Fig. 9 Axonometric drawing of one of the buildings in Gellert. Adapted from GXN.*



Fig. 10 Dismantling of HC elements in Gellerup. Image source: GXN

Components



Data Template

The data utilised in this thesis is founded on an Excel template created by GXN. The template comprises several data points illustrated in the diagram to the right. Data showcased in the diagram are arbitrary, and not all the data points were available during the process of this thesis. However, it has still been incorporated into the development of the tool to assess later which data points are relevant for the project. While the template encompasses all concrete elements, this master's thesis focuses exclusively on hollow-core slabs and wall elements. However, the tool is designed to allow future development to handle other elements.

To make data accessible, testing is suggested on the elements in question, plausibly based on the Norwegian standard mentioned in the discourse chapter. The data employed in this work originates from the inventory of the buildings, which includes examining existing drawings and site visits, both conducted by GXN.

Fig. 11 Data points included in the template received from GXN. Own illustration

### Site for Implementation

The site chosen for implementing the ideas presented in this thesis is located in the southwestern region of Bergsjön, designated for introducing new residential structures to enhance the urban fabric, accessibility, and safety for its inhabitants. The site spans approximately 15 hectares and is jointly owned by Familjebostäder in Göteborg AB and the Municipality of Göteborg. It is located roughly 8 kilometres northeast of Göteborg's central district near Gårdsås Torg.

The chosen location offers a diverse range of building programs that offer a testing ground for the theories posited in this thesis, particularly across different architectural typologies. The development plan aims to erect about 100 new homes, with a mix of low-rise multi-family houses and rowhouses, with the goal being to diversify housing types and scales to enhance community living and safety.

The site is divided into six distinct development areas, with this thesis focusing on areas 2, 3, and 6. Development area 2 is planned for new rowhouses, which are intended to diversify the area's housing offerings. These two-story homes are expected to provide approximately 27 new residential units.

The third development area is adjacent to the new local street. It proposes two-story multi-family buildings, adding around 29 new homes. These buildings will feature ground-floor access with storage and loft pathways.

The last development area is slated to construct two new multi-story residential buildings, ranging from three to four stories high, adding around 29 units to the housing capacity. The development plan states that designs should include underground parking to maximise usable outdoor space; however, for the purpose of this thesis, this component has been simplified to facilitate the implementation of the tool developed.



Fig. 12 Orthophoto of Gothenburg showing location of site. Image source: Google Earth.

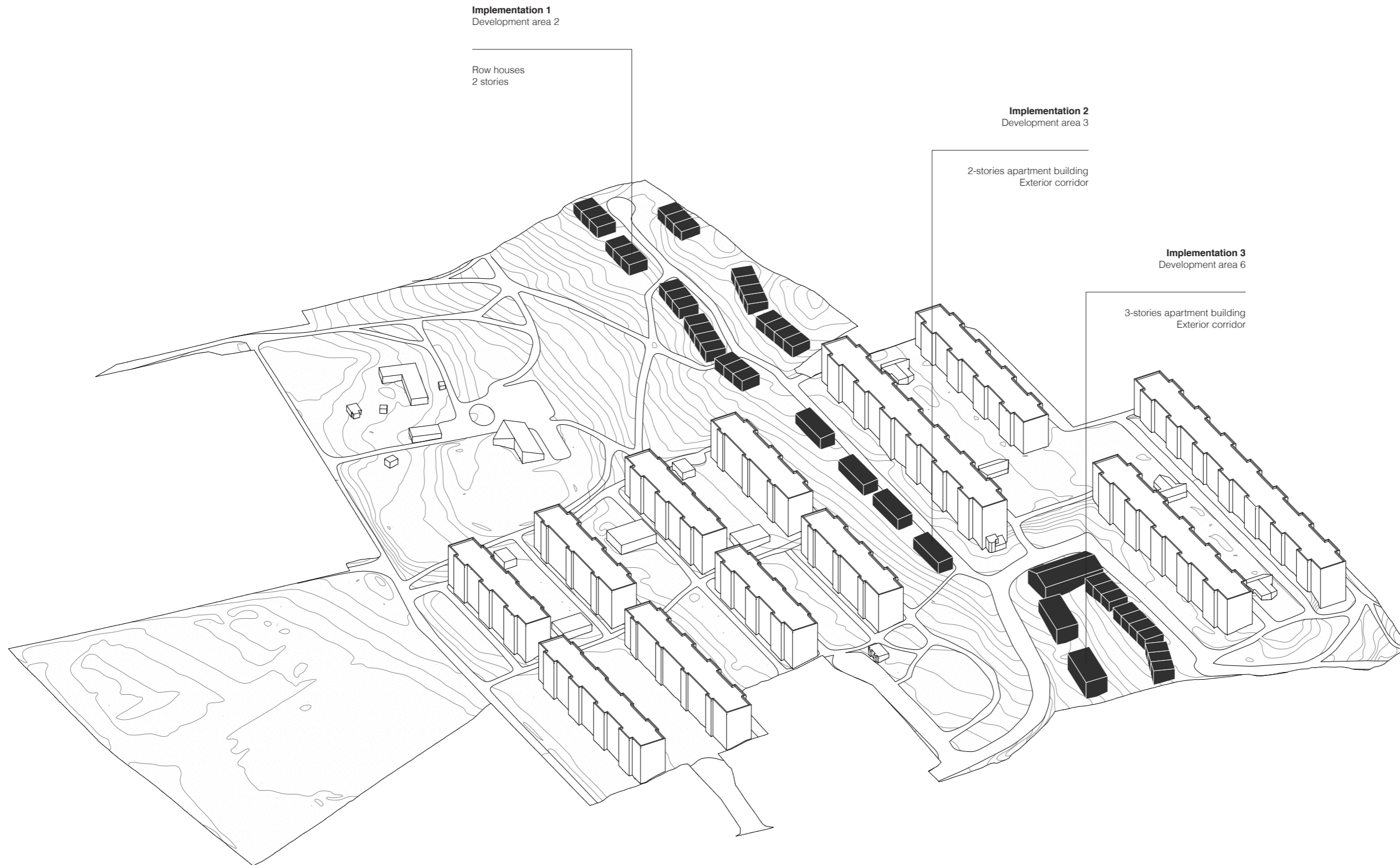

Fig. 13 Axonometric drawing of site. Own illustration

## Analysis & Approach

There are fundamentally two paths in reusing structural elements. The first approach involves mapping elements to a predetermined design. In this scenario, the design is already established, and the task is to fit the existing elements into this predetermined design. Within this method, the properties of the existing elements do not influence the design; instead, the elements are adapted as much as possible to fit the design.

The advantage of this approach is that it allows for the design and planning process to proceed “as usual”, meaning the design process is not significantly affected by the reuse. The challenge of finding or modifying elements to fit the design becomes a subsequent issue. The downside of this method is that it may not fully leverage the potential of the elements, leading to material waste. For instance, a scenario might arise where an element that could span its entire length is only used to half its potential. Another scenario might involve failing to find a suitable element for a specific location, necessitating virgin materials.

The second alternative entails having a program for the building that can guide design parameters. The design is not finalised and thus can be influenced by the elements' geometric, material, and structural properties. This method may limit architects in their design process; however, it provides a better opportunity for the elements to be utilised to their full potential, thereby reducing material waste and the building's overall CO2 emissions.

Of course, there are numerous scenarios between these two, and the future process will likely be a combination of both. Yet, discussing this in the context of the synergy between limitations and free design choices is relevant. An absolutist stance might argue that the challenges we face are so significant that there is no room for reluctance towards sacrifices and that the creative freedoms architects and engineers have enjoyed thus far are privileges that should not be taken for granted in the future. It would contend that existing resources must guide the built environment in a world of limited resources.

Naturally, the issue is more complex than this, and a more realistic scenario involves finding a synergy between the creative process and the material limitations we face. Thus, the question that must be answered is: What will this synergy look like? At the heart of the challenges we face concerning our role as architects is the notion that our dependence on virgin materials will be our downfall.

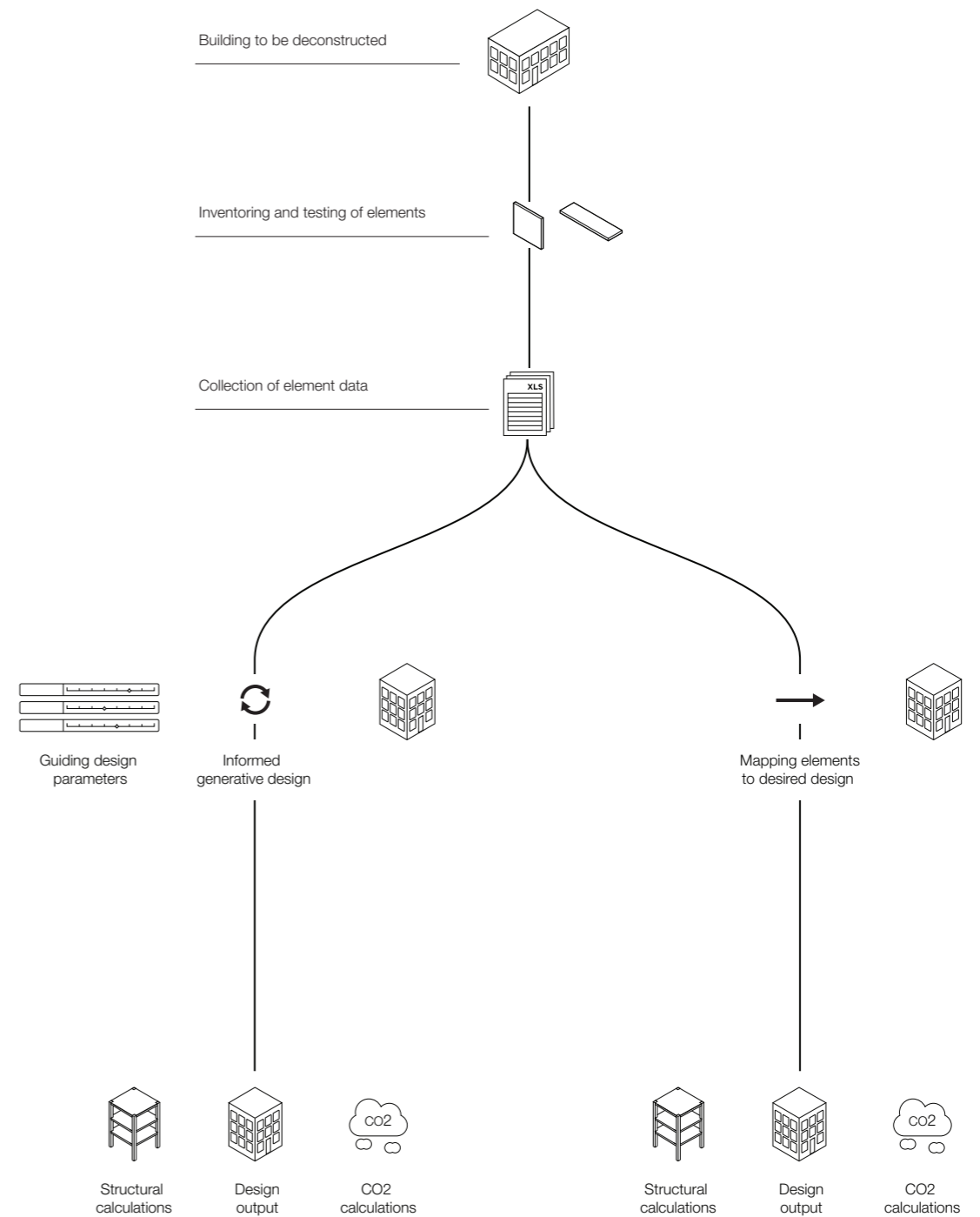

Fig. 13 The two different design strategies when working with reused elements. Own illustration.

## Result

This chapter presents the study's results, which are structured into three parts: the Grasshopper tool, data management within the design process, and the tool's implementation. The tool was developed in C# as a plugin for Grasshopper, utilising an Excel template provided by GXN. This development phase concentrated on managing and utilising data points to establish load-bearing modules, which guided subsequent design phases.

An analysis was undertaken to determine which data points were most instrumental in developing the tool, focusing on optimising the design process. This analysis also identifies potential applications of specific data beyond the immediate design phase, which may prove beneficial in other aspects of the recycling process. The tool subsequently served as a guide throughout the design process. It facilitated the creation of load-bearing modules that underpinned the implementations in Bergsjön, leading to the development of three architectural projects: a townhouse, a small apartment building, and a larger apartment complex.

Further sections of this chapter will delve deeper into the tool's functionalities and outputs and the variables influencing these outputs. An evaluation of the tool's data utility is presented, emphasising the relevance of specific data at the design stage and its potential utility in subsequent phases. This assessment supports including such data within the tool, enabling targeted extraction for specific applications at future stages. The chapter will conclude with the implementation process and result, illustrating how the tool's output—the load-bearing modules—has directed the design process. It will also address the necessary adjustments made to the structural elements to accommodate specific design requirements and project goals.



*Fig. 14 Exterior perspective of third implementation. Own illustration.*

## Tool

The focus of this plugin was the effective positioning of load-bearing wall elements and hollow-core slabs, based on the assumption that the hollow-core slabs can span their originally designed distance and that the walls can support loads as per established guidelines from the Swedish Concrete Association's specifications for the dimensioning of wall elements.

The Grasshopper plugin is bifurcated into two main parts, containing five components. The first segment addresses data input and the translation of data types from Excel to Grasshopper. The first component in this part is handling data input from Excel. The subsequent component translates this Excel data into an interpretable format by Grasshopper. The final component in this segment outputs 3D elements into Rhino and generates a summary of data associated with each element type.

The data incorporated at this stage are Element category, Element Type, Harmful Substances, Dimensions (LxWxH), Number of Elements, Placement, Condition, End of Life Scenario, Existing Drawings, Documentation, Rebar, Compressive Strength, Environment Certification, Construction Class, Static

System, Function, Joints, Accessibility, Environment Declaration, Flexibility, Kg CO2. While the plugin has been built around these data types, not all may be necessary for the later stages of the process, and the data types are revised in the subsequent part of this chapter.

The second segment of the plugin pertains to the actual placement of elements. It comprises two components: one managing design parameters and another executing them along with the data from the first segment through a code that facilitates the element placement. This segment also considers 'genes', which currently only determine the inclusion of available elements and are randomly generated. There is potential for these genes to handle design parameters later if optimisation for utilising available elements is desired. In such a case, the optimisation algorithm Wallacei would be implemented to refine the design to suit the available elements best.

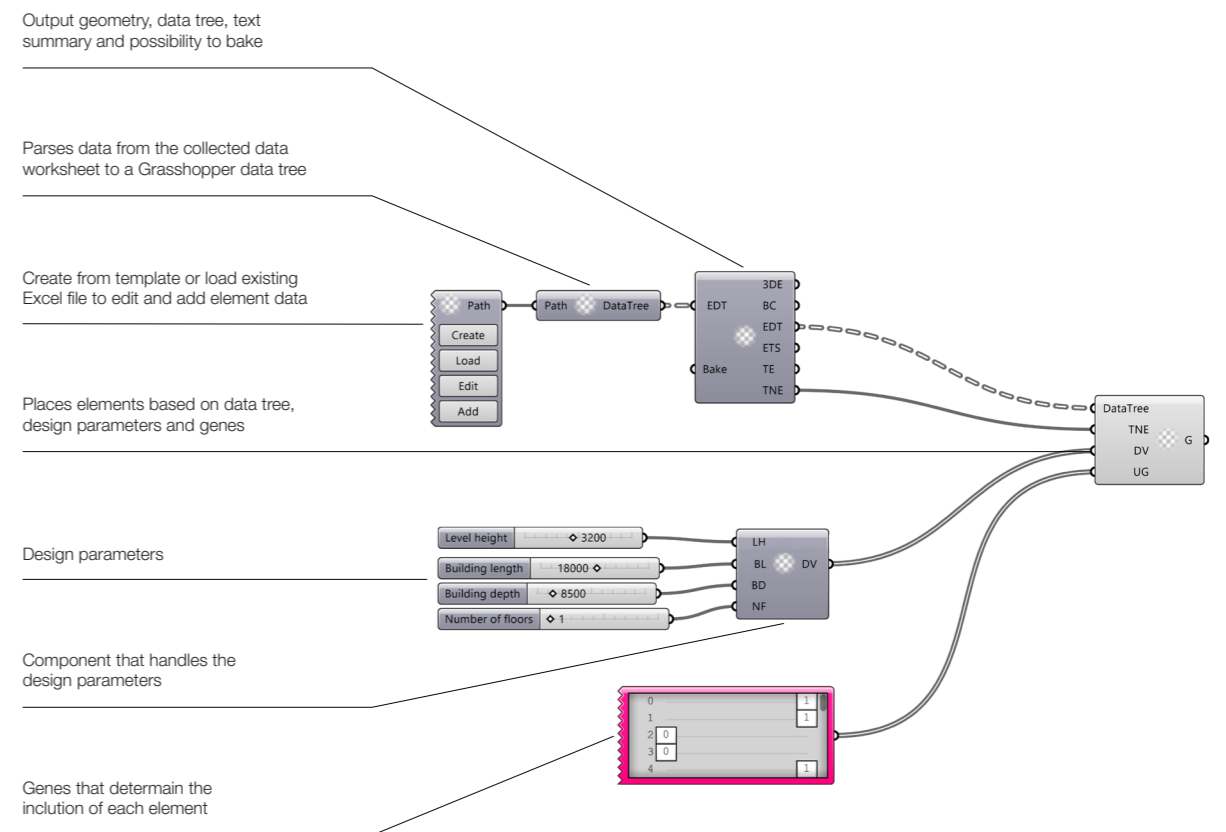

Fig. 15 Visualisation of tool interface in Grasshopper. Own illustration.

### Output

The tool outputs structural modules consisting of load-bearing wall and hollow-core slab elements. These modules are determined by the design parameters of building depth, length, and number of floors. A parameter called "level height" has also been introduced to enhance flexibility and accommodate increased ceiling heights. This parameter encompasses adding a wooden beam between the wall elements and hollow-core slabs. By adjusting the height of this wooden beam, the ceiling height can be modified accordingly.

The adjustment of design parameters is managed within Grasshopper, serving as a tool for identifying suitable load-bearing modules for architectural projects. These modules are intended to act as a guide that can be tailored according to the specific conditions and requirements of the project. This process allows for strategic adaptation, enabling the structural modules to align with the building design's architectural goals and structural integrity.

#### Example 1

level height= 2300 mm  
building length= 21000 mm  
building depth= 12000 mm  
number of floors= 4

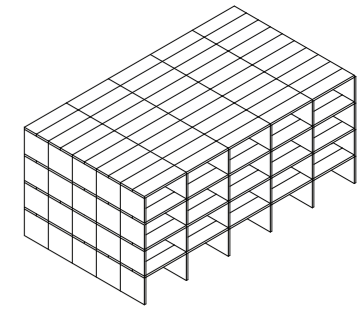

#### Example 2

level height= 2300 mm  
building length= 21000 mm  
building depth= 9600 mm  
number of floors= 3

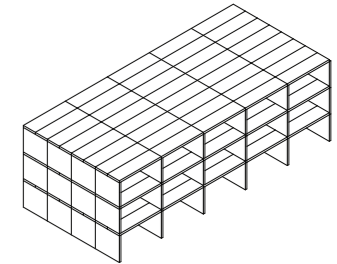

#### Example 3

level height= 2300 mm  
building length= 16800 mm  
building depth= 9600 mm  
number of floors= 3

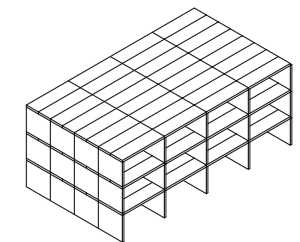

#### Example 4

level height= 2300 mm  
building length= 12600 mm  
building depth= 7200 mm  
number of floors= 2

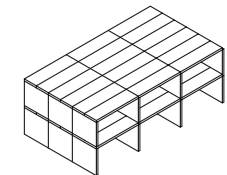

Fig. 16 Axonometric drawing of example output. Own illustration.

### Data Processing

During the development of the tool, it was determined which data points were relevant to the design process. Dimensions was identified as the most crucial data type, assuming the elements pass necessary quality tests. Beyond geometry, marking each element with a unique identifier is essential, enabling access to additional data through key-value lookup. For example, a hollow-core slab might be labelled as HC type 1.01. Subsequent relevant data for calculations, both structural and carbon emission-related, include the compressive strength of the material and the carbon emissions per element. These emissions could represent the embedded carbon within the element or those associated with dismantling, transportation, storage, and reconstruction. For calculating the life cycle analysis of the new building, the last mentioned is more relevant. Additionally, the embedded CO2 for these elements might be unavailable for the buildings erected in the '60s-80s.

From a computational perspective, safety margins for reuse need to be established. While there are standardised margins for calculating new materials or elements, no such standards appear for reused materials based on the research conducted in this thesis. Currently, the placement of elements within the

tool is primarily dictated by geometry and the identity marking of each element. This setup enables the tool to track which elements are placed and their positions, preparing it for future carbon emissions calculations and structural integrity by accessing the data associated with each element through a data tree structure within the tool.

Fig. 17.2 Data associated with each element. Screenshot of Visual Studio interface.

IEnumerable Visualizer

KeyValuePair`2	KeyValuePair`2.key	KeyValuePair`2.value
[HC_42.12.00.0-0, ElementDataManager.ElementDictionaryData]	HC_42.12.00.0-0	ElementDataManager.ElementDictionaryData
[HC_42.12.00.0-1, ElementDataManager.ElementDictionaryData]	HC_42.12.00.0-1	ElementDataManager.ElementDictionaryData
[HC_42.12.00.0-2, ElementDataManager.ElementDictionaryData]	HC_42.12.00.0-2	ElementDataManager.ElementDictionaryData
[HC_42.12.00.0-3, ElementDataManager.ElementDictionaryData]	HC_42.12.00.0-3	ElementDataManager.ElementDictionaryData
[HC_42.12.00.0-4, ElementDataManager.ElementDictionaryData]	HC_42.12.00.0-4	ElementDataManager.ElementDictionaryData
[HC_42.12.00.0-5, ElementDataManager.ElementDictionaryData]	HC_42.12.00.0-5	ElementDataManager.ElementDictionaryData
[HC_42.12.00.0-6, ElementDataManager.ElementDictionaryData]	HC_42.12.00.0-6	ElementDataManager.ElementDictionaryData
[HC_42.12.00.0-7, ElementDataManager.ElementDictionaryData]	HC_42.12.00.0-7	ElementDataManager.ElementDictionaryData
[HC_42.12.00.0-8, ElementDataManager.ElementDictionaryData]	HC_42.12.00.0-8	ElementDataManager.ElementDictionaryData
[HC_42.12.00.0-9, ElementDataManager.ElementDictionaryData]	HC_42.12.00.0-9	ElementDataManager.ElementDictionaryData
[HC_42.12.00.0-10, ElementDataManager.ElementDictionaryData]	HC_42.12.00.0-10	ElementDataManager.ElementDictionaryData
[HC_42.12.00.0-11, ElementDataManager.ElementDictionaryData]	HC_42.12.00.0-11	ElementDataManager.ElementDictionaryData
[HC_42.12.00.0-12, ElementDataManager.ElementDictionaryData]	HC_42.12.00.0-12	ElementDataManager.ElementDictionaryData
[HC_42.12.00.0-13, ElementDataManager.ElementDictionaryData]	HC_42.12.00.0-13	ElementDataManager.ElementDictionaryData

Fig. 17.1 Data access through key-value look up. Screenshot of Visual Studio interface.

IEnumerable Visualizer

ElementDictionaryData	ElementDictionaryData.Length	ElementDictionaryData.Width	ElementDictionaryData.Height	ElementDictionaryData.KgCO2	ElementDictionaryData.XCoordinate	ElementDictionaryData.YCoordinate	ElementDictionaryData.ZCoordinate
ElementDataManager.ElementDictionaryData	4200	1200	180	0	0	0	2536
ElementDataManager.ElementDictionaryData	4200	1200	180	0	4200	0	2536
ElementDataManager.ElementDictionaryData	4200	1200	180	0	8400	0	2536
ElementDataManager.ElementDictionaryData	4200	1200	180	0	12600	0	2536
ElementDataManager.ElementDictionaryData	4200	1200	180	0	0	1200	2536
ElementDataManager.ElementDictionaryData	4200	1200	180	0	4200	1200	2536
ElementDataManager.ElementDictionaryData	4200	1200	180	0	8400	1200	2536
ElementDataManager.ElementDictionaryData	4200	1200	180	0	12600	1200	2536
ElementDataManager.ElementDictionaryData	4200	1200	180	0	0	2400	2536
ElementDataManager.ElementDictionaryData	4200	1200	180	0	4200	2400	2536
ElementDataManager.ElementDictionaryData	4200	1200	180	0	8400	2400	2536
ElementDataManager.ElementDictionaryData	4200	1200	180	0	12600	2400	2536
ElementDataManager.ElementDictionaryData	4200	1200	180	0	0	3600	2536
ElementDataManager.ElementDictionaryData	4200	1200	180	0	4200	3600	2536
ElementDataManager.ElementDictionaryData	4200	1200	180	0	8400	3600	2536
ElementDataManager.ElementDictionaryData	4200	1200	180	0	12600	3600	2536
ElementDataManager.ElementDictionaryData	4200	1200	180	0	0	4800	2536
ElementDataManager.ElementDictionaryData	4200	1200	180	0	4200	4800	2536
ElementDataManager.ElementDictionaryData	4200	1200	180	0	8400	4800	2536
ElementDataManager.ElementDictionaryData	4200	1200	180	0	12600	4800	2536
ElementDataManager.ElementDictionaryData	4200	1200	180	0	0	6000	2536
ElementDataManager.ElementDictionaryData	4200	1200	180	0	4200	6000	2536
ElementDataManager.ElementDictionaryData	4200	1200	180	0	8400	6000	2536
ElementDataManager.ElementDictionaryData	4200	1200	180	0	12600	6000	2536
ElementDataManager.ElementDictionaryData	4200	1200	180	0	0	0	5072
ElementDataManager.ElementDictionaryData	4200	1200	180	0	4200	0	5072
ElementDataManager.ElementDictionaryData	4200	1200	180	0	8400	0	5072
ElementDataManager.ElementDictionaryData	4200	1200	180	0	12600	0	5072
ElementDataManager.ElementDictionaryData	4200	1200	180	0	0	1200	5072
ElementDataManager.ElementDictionaryData	4200	1200	180	0	4200	1200	5072
ElementDataManager.ElementDictionaryData	4200	1200	180	0	8400	1200	5072
ElementDataManager.ElementDictionaryData	4200	1200	180	0	12600	1200	5072
ElementDataManager.ElementDictionaryData	4200	1200	180	0	0	2400	5072
ElementDataManager.ElementDictionaryData	4200	1200	180	0	4200	2400	5072
ElementDataManager.ElementDictionaryData	4200	1200	180	0	8400	2400	5072
ElementDataManager.ElementDictionaryData	4200	1200	180	0	12600	2400	5072
ElementDataManager.ElementDictionaryData	4200	1200	180	0	0	3600	5072
ElementDataManager.ElementDictionaryData	4200	1200	180	0	4200	3600	5072
ElementDataManager.ElementDictionaryData	4200	1200	180	0	8400	3600	5072
ElementDataManager.ElementDictionaryData	4200	1200	180	0	12600	3600	5072

### Implementations

The tool has been implemented across three different proposals, starting from the output of structural modules generated by the Grasshopper tool. These were then modified to integrate the detailed plan for Siriusgatan. In each building, glulam beams have been incorporated to enhance flexibility in the floor plan and to increase the level height from the initial 2.3 meters, given by the existing concrete wall elements, to 2.6 meters. The implementation is intended to highlight how slight modifications to these structural modules can result in architectural qualities, focusing on creating high-quality living spaces where the reused concrete elements are showcased structurally and architecturally.

Combining wood and reused concrete has been particularly important in the implementation, as wood is a complement that allows adjustments in the load-bearing modules. Efforts have been made to retain the load-bearing structure as much as possible and reuse the material to its full potential. The intersection of concrete and wood is also significant from an environmental perspective, considering wood as a sustainable alternative within the construction industry.

Additionally, it has been essential to demonstrate the variety of building types that can be produced using this tool and the achievable variations in floor plans. Implementation is critical in evaluating how well the tool functions as intended and assessing its potential for improvement. Through this implementation, a more concrete discussion about future scenarios and applications for the tool and the general potential for reuse can be facilitated.

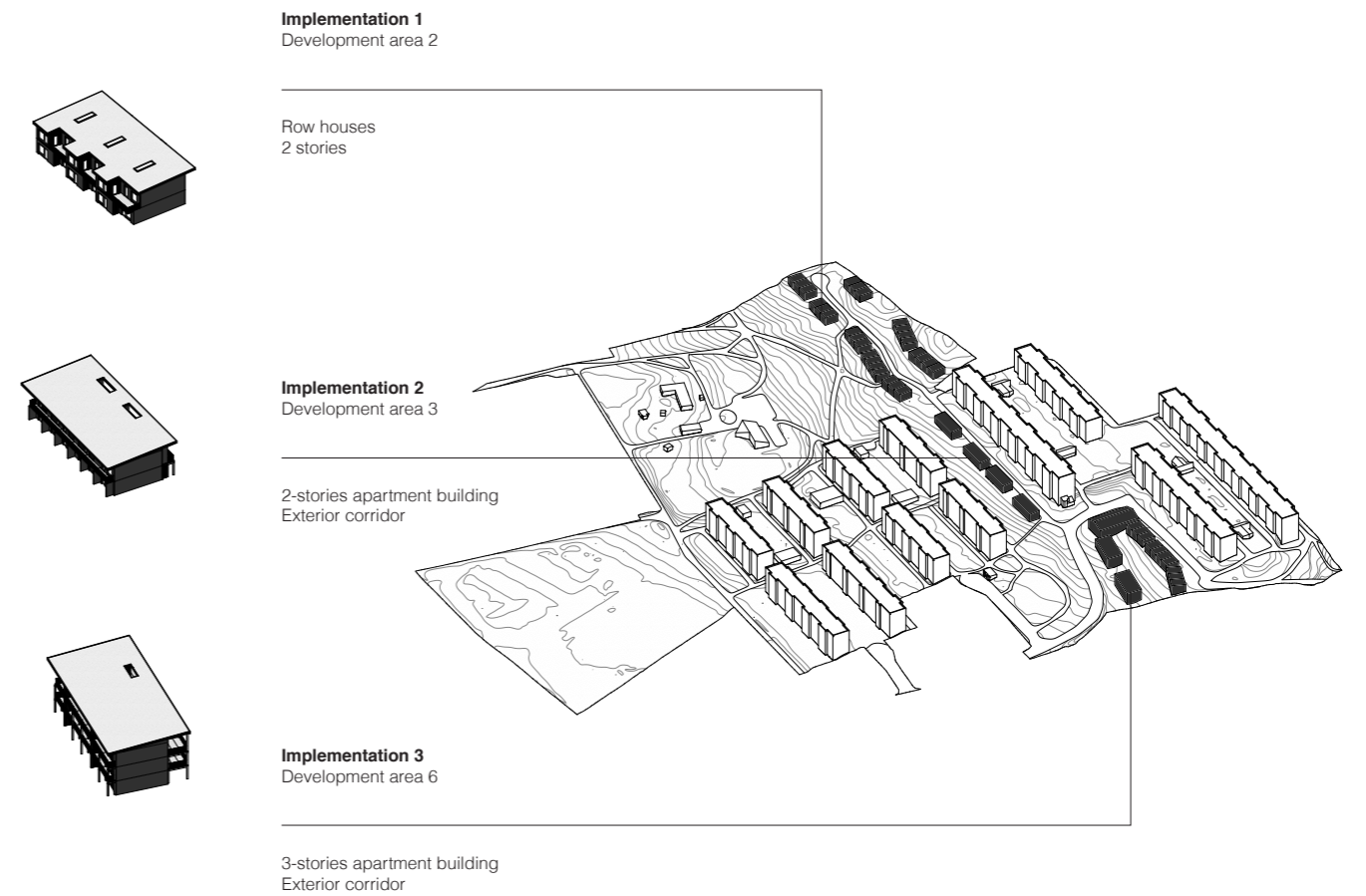

Fig. 18 Axonometric drawing of site and proposals. Own illustration.

## Development Area 2

Development Area 2 asks for row houses or semi-detached houses. In this implementation, the building design utilises two modules generated with the tool. These modules are combined to create a varied façade and include terraces at the back of the rows of houses. Each row comprises three units, with each unit constructed from two modules. Each unit incorporates 50 hollow-core slab elements, five of which are cut to accommodate terrace and skylights. A total of 45 wall elements are employed in the construction of one unit. Eighteen are retained, while the remaining are modified to allow for openings in the façade and interior spaces. Due to the requirement to cut several elements to fit specific design needs, some are repurposed at different locations within the structure.

The layout is designed to be open and flexible within the frame of the modules. The implementation showcases the load-bearing properties of the reclaimed concrete by a circular pathway around the staircase adjacent to the load-bearing concrete wall, making it a centrepiece of the ground floor. A skylight above the staircase illuminates the hollow-core slabs and the load-bearing concrete wall, bringing natural light to the central dining area.

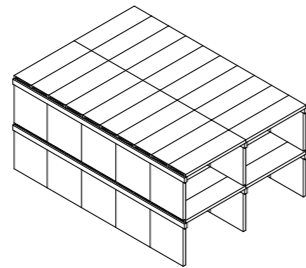

Fig. 19 Axonometric drawing of tool output for the first implementation. Own illustration.

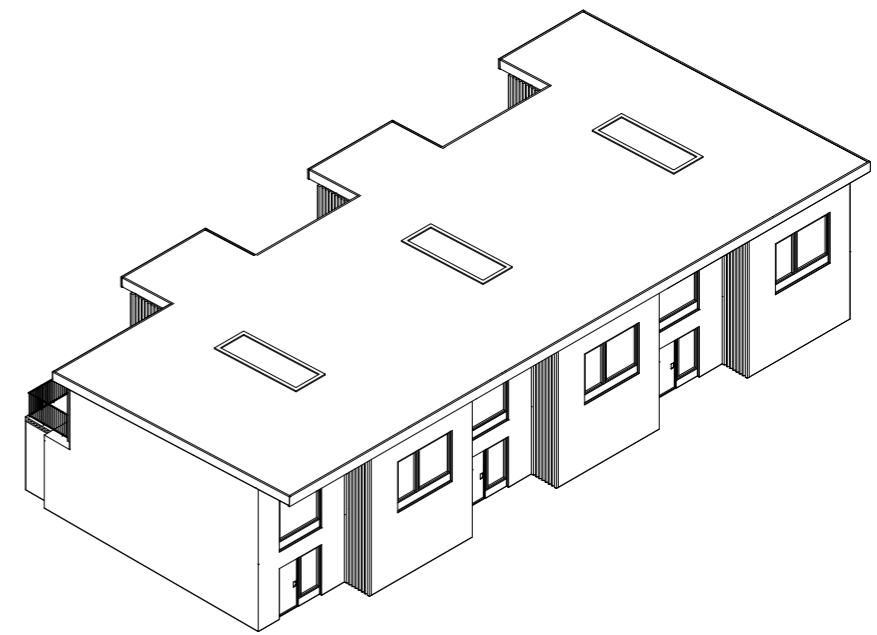
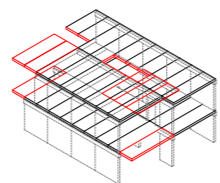

Fig. 20 Axonometric drawing of the first implementation. Own illustration.



1. Hollow core slabs are cut and some are removed
2. Wall elements are cut
3. Additional reused concrete walls and new glulam beams are added.

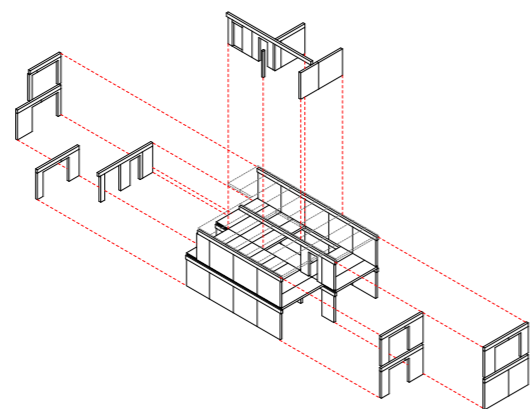
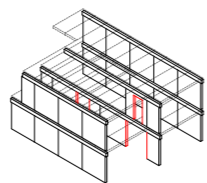
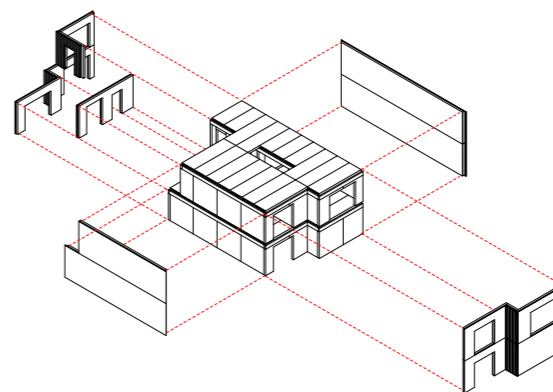

Fig. 21.1 Axonometric drawing of modifications for the first implementation. Own illustration.



4. Insulation, rockwool and plaster are added, creating sandwich walls with the reused concrete walls
5. Reused hollow core slabs, insulation, and I-beams on plinths make up the foundation. Roof, doors and windows are added.

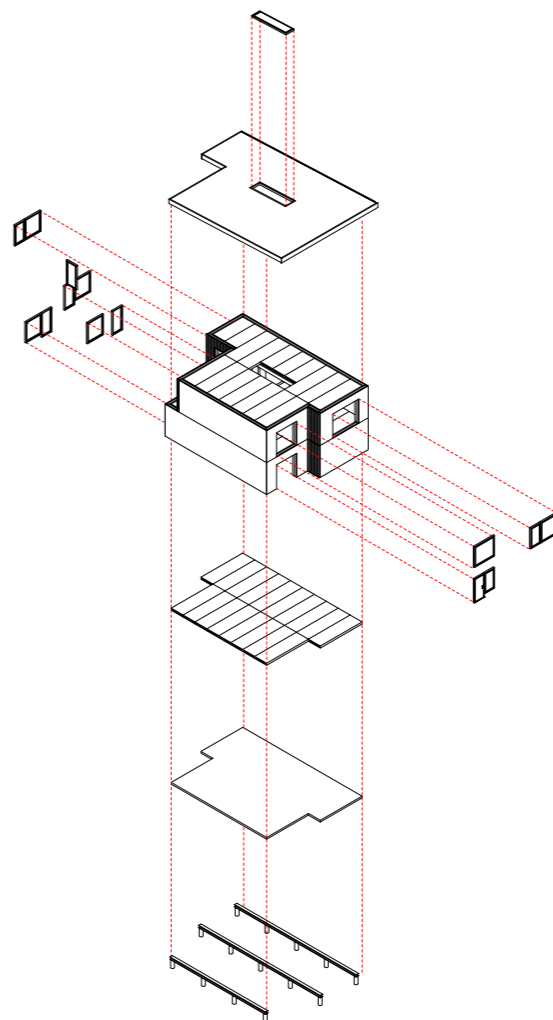
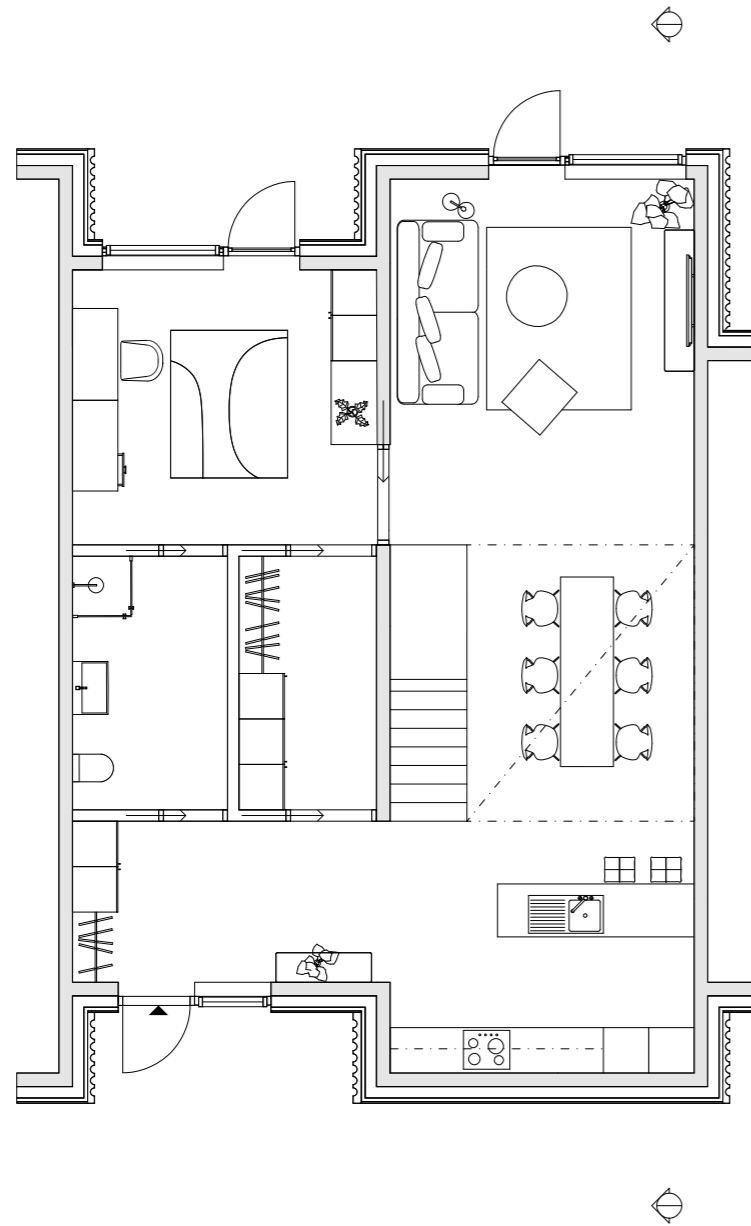
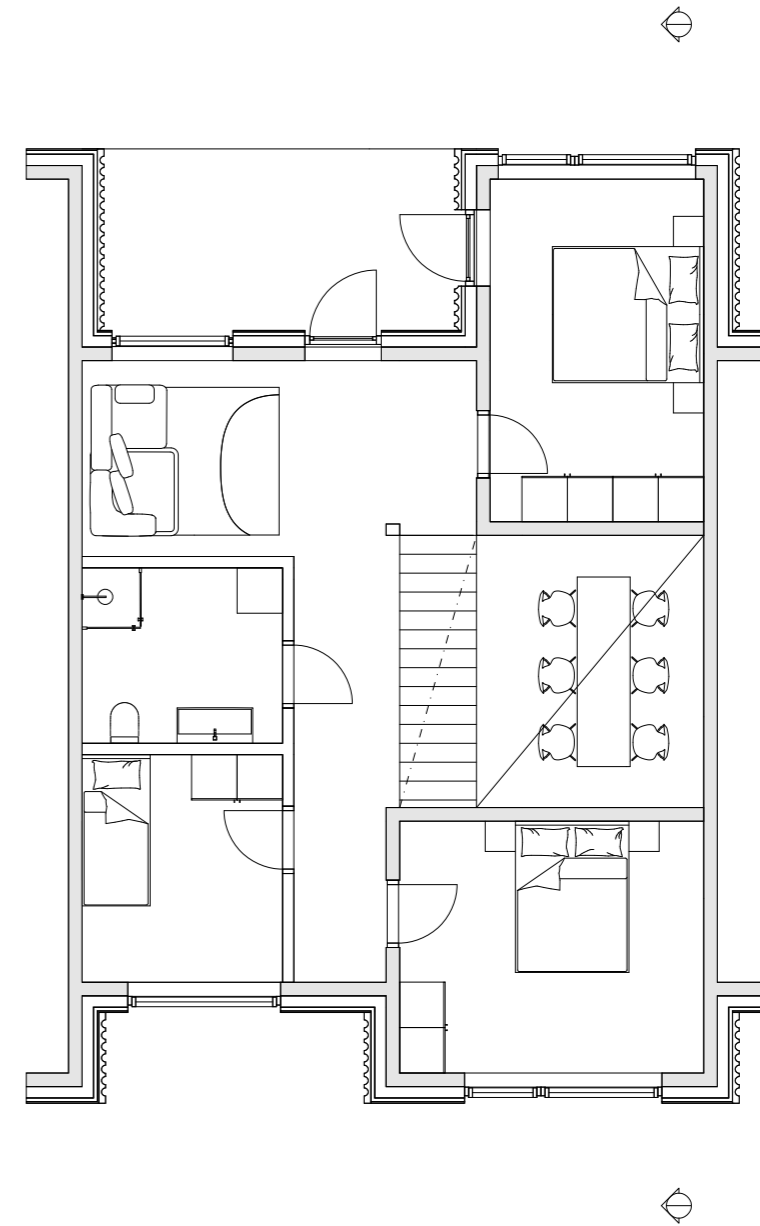

Fig. 21.2 Axonometric drawing of modifications for the first implementation. Own illustration.



Plan drawing 1:200  
Ground floor



Plan drawing 1:200  
Upper floor



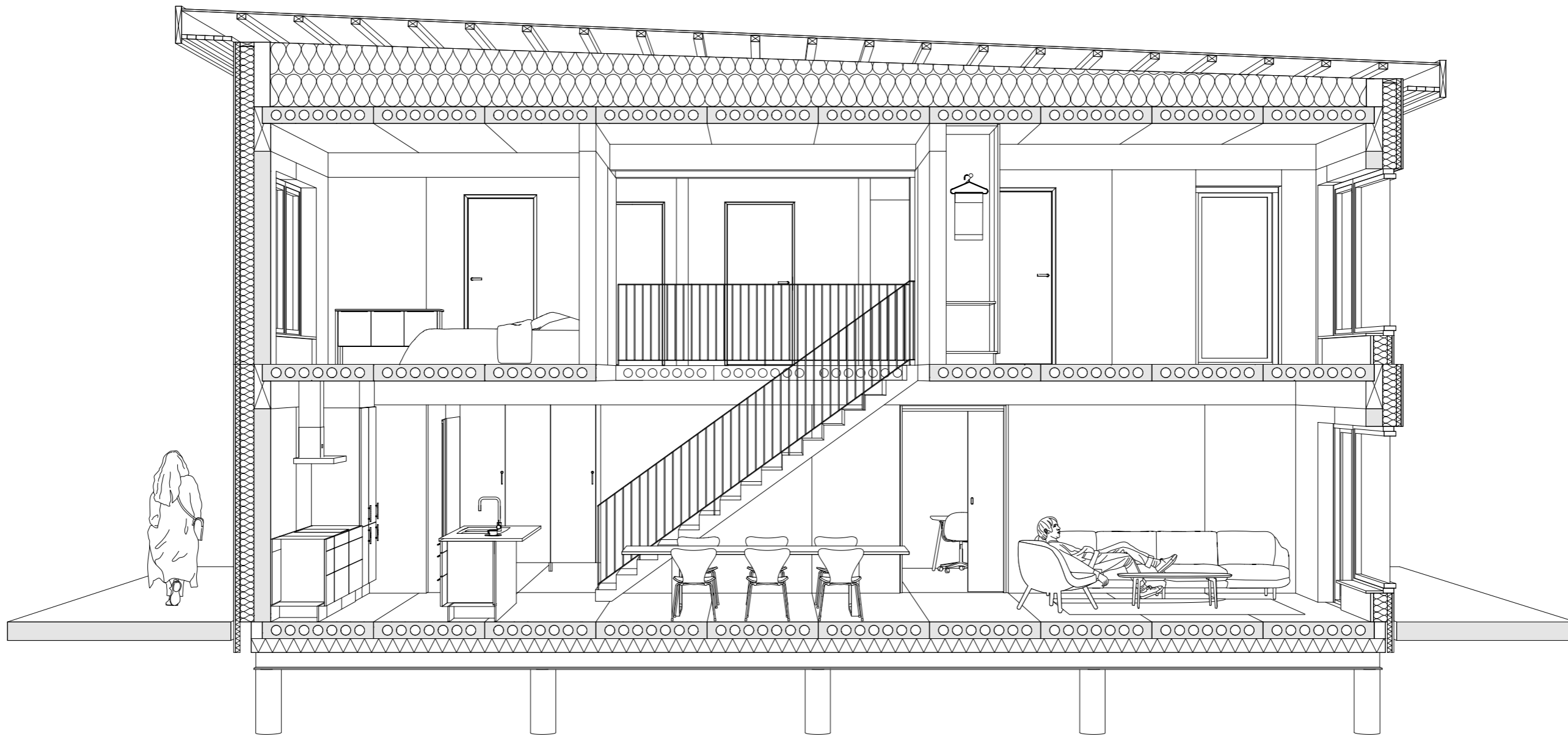

Section 1:100



Fig. 22 Exterior perspective of first implementation. Own illustration.



Fig. 23 Interior perspective of first implementation. Own illustration.

### Development Area 3

Development area three comprises four two-story multi-family buildings. According to the local plan, the second floor should be accessed via an exterior corridor. The module generated with the tool has been extended by an additional hollow-core slab in depth to create a slightly deeper floor plan, resulting in an extension of half a wall longitudinally.

In one house unit, 126 hollow-core slabs are used and preserved intact. Beyond the load-bearing structure, the building is complemented by wall elements in the facade that serve a stabilising function. A total of 56 wall elements are incorporated, of which 30 are preserved entirely and form the vertical support. Additionally, the exterior corridor and balcony have been constructed using hollow-core slab elements, adding 16 more to the structure.

Due to the requirement for an exterior corridor, the floor plan in this implementation was somewhat challenging. Efforts were made to avoid placing bedrooms along the walkway. Where necessary, the hollow-core slab element adjacent to the bedroom window in the facade was removed to prevent direct access to the window from the walkway. Partitions have been made using half-length hollow core slabs;

these are suggested to be hollow-core slabs that either failed quality tests or were surplus.

Three different types of apartment layouts were explored in this implementation: a four-room with a kitchen, a three-room with a kitchen, and a small two-room unit. Implementing an overlying glulam beam has allowed for a flexible floor plan, enabling a circular pathway in the largest apartment while attempting to preserve as much of the load-bearing structure as possible. The partitions towards the walkway create private spaces at entrances where a patio can be established.

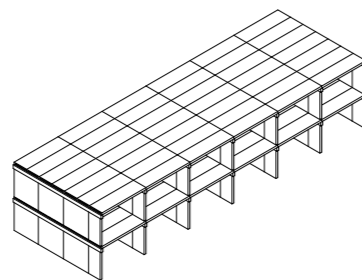
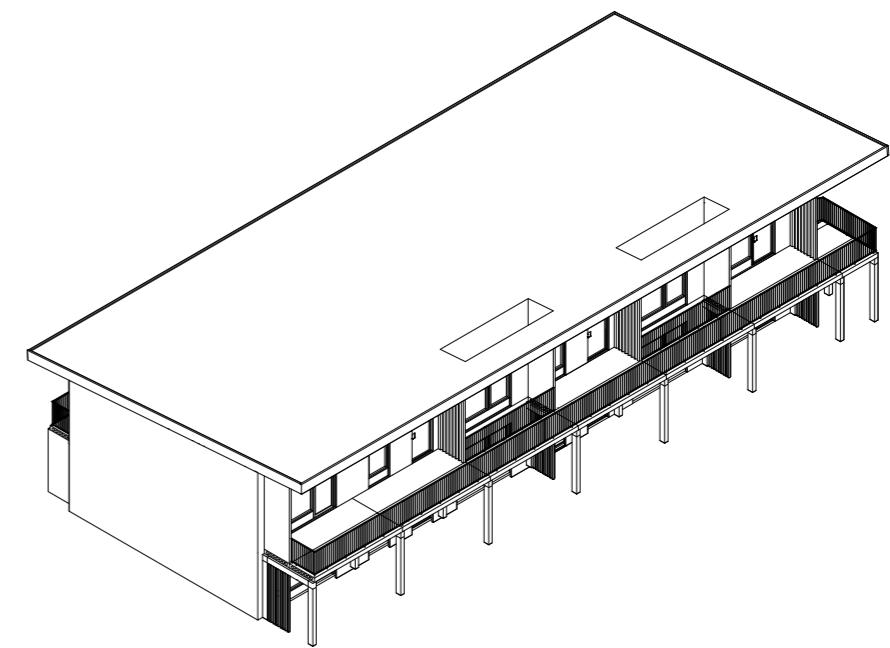

Fig. 24 Axonometric drawing of tool output for the second implementation. Own illustration.

Fig. 25 Axonometric drawing of the second implementation. Own illustration.



1. Wall elements are cut
2. Additional reused concrete walls and new glulam beams are added.
3. Non load bearing frame walls are added.

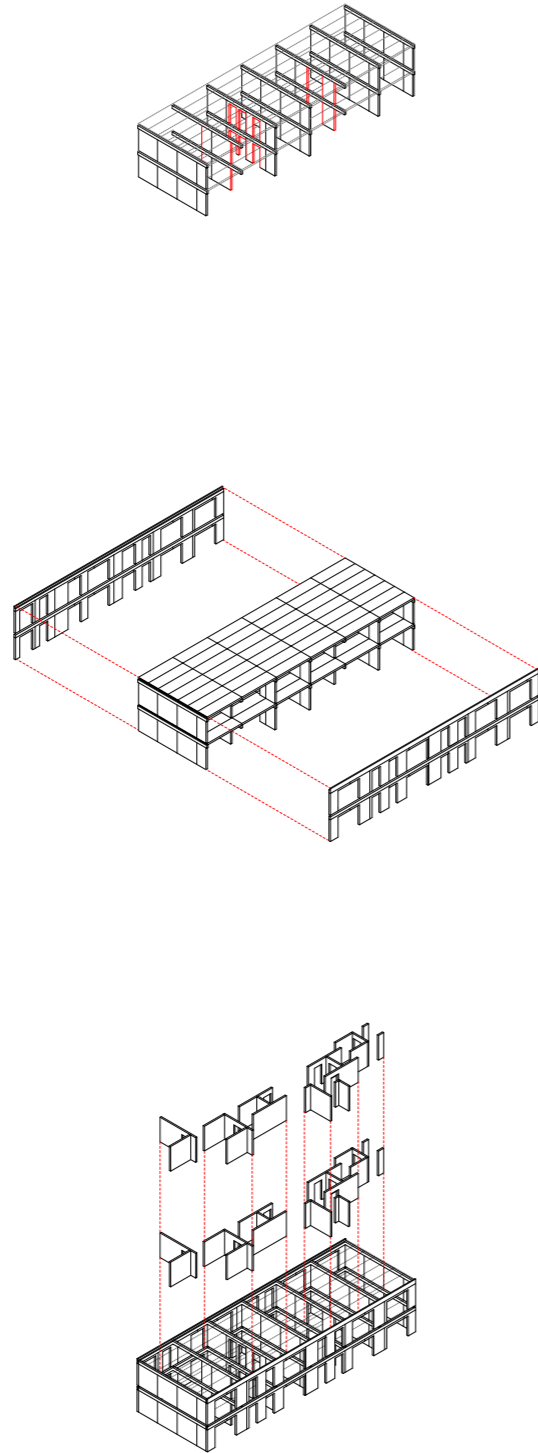
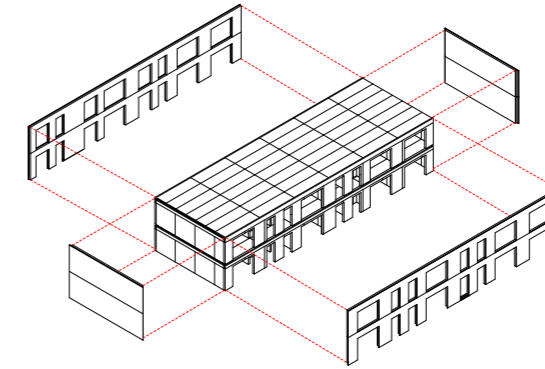

Fig. 26.1 Axonometric drawing of modifications for the first implementation. Own illustration.



4. Insulation, rockwool and plaster are added, creating sandwich walls with the reused concrete walls

5. Reused hollow core slabs, insulation, and I-beams on plinths make up the foundation. Roof, doors and windows are added.

Exterior corridor is built from reused hollow core slabs and glulam columns. Hollow core slabs that do not meet quality testing are used as facade elements and partition walls

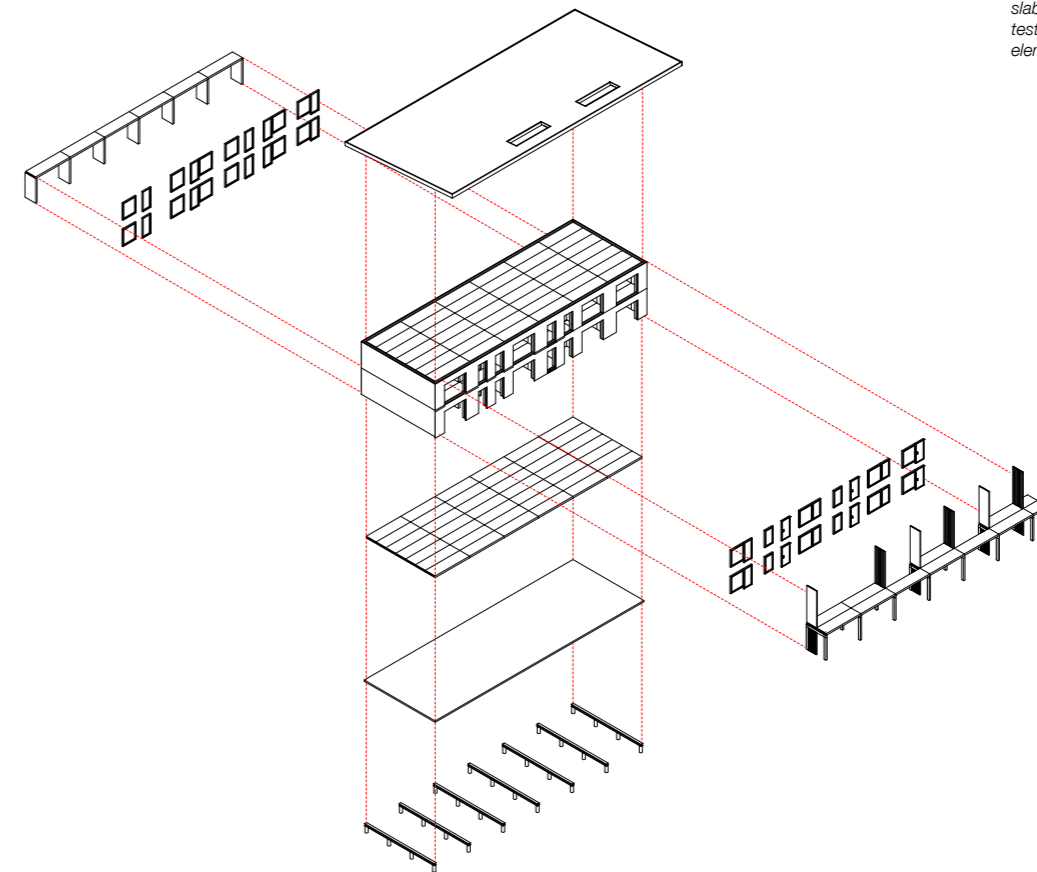
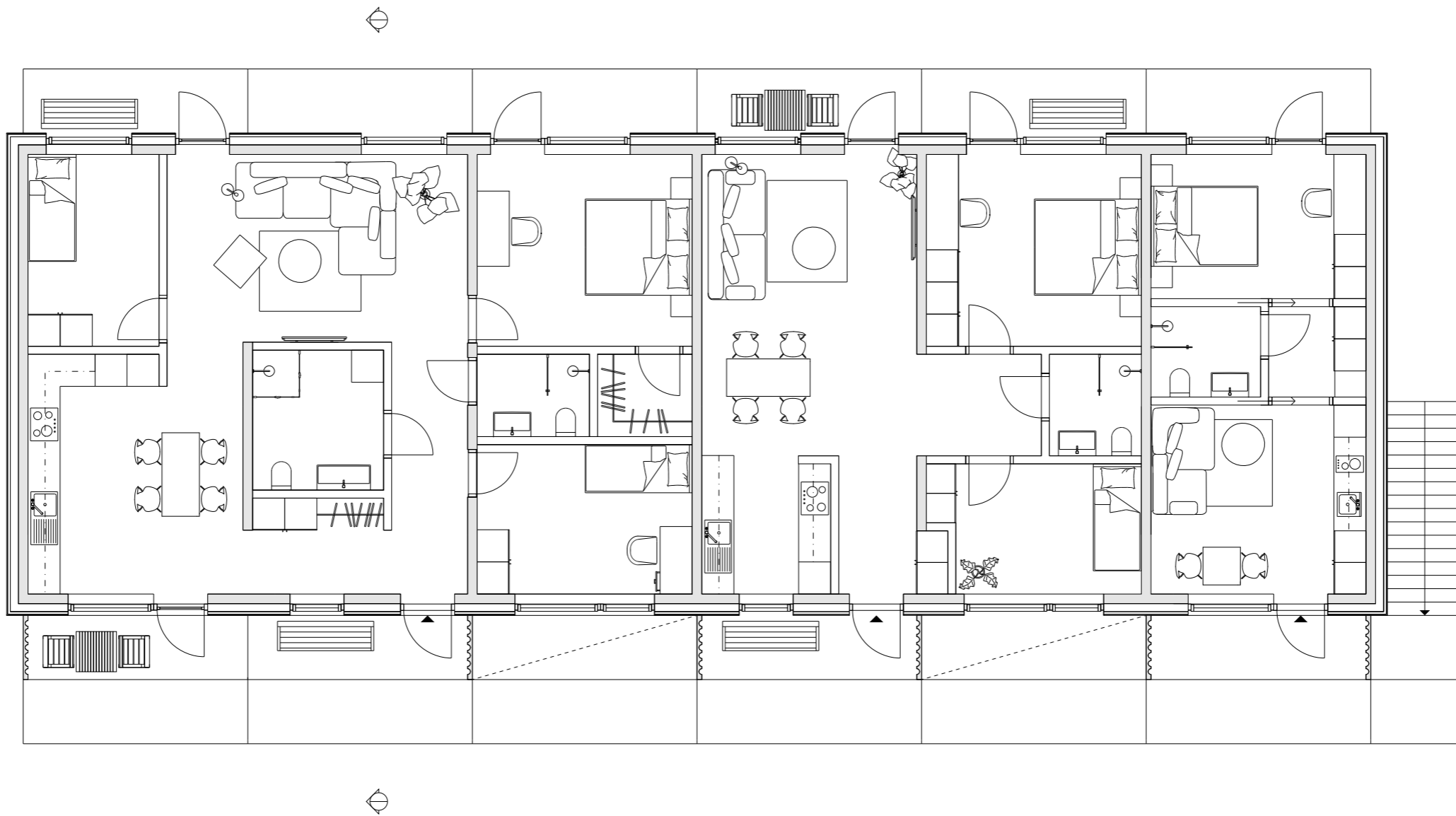
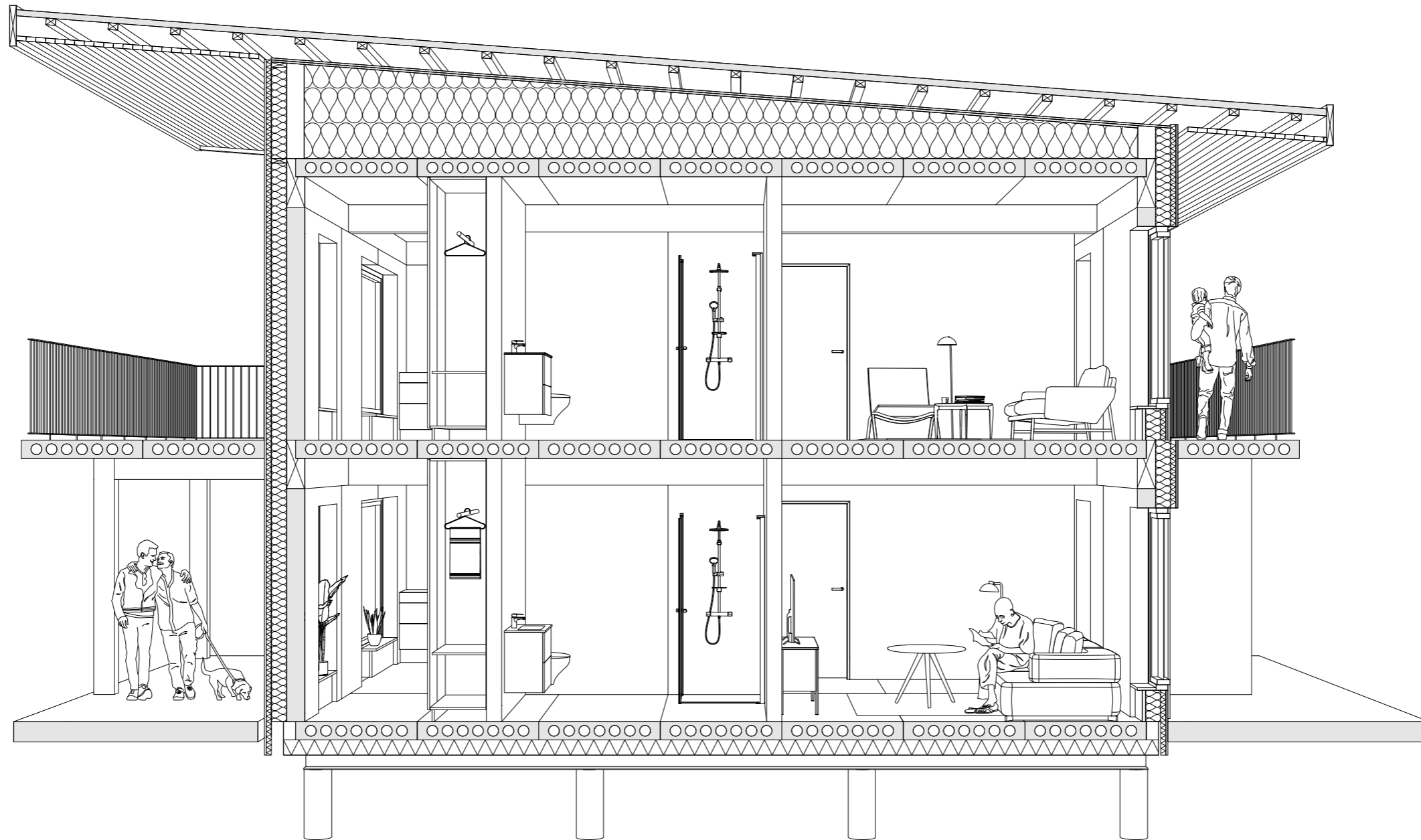

Fig. 26.2 Axonometric drawing of modifications for the first implementation. Own illustration.



Plan drawing 1:200





Section 1:100



Fig. 27 Exterior perspective of second implementation. Own illustration.



Fig. 28 Interior perspective of second implementation. Own illustration.

### Development Area 6

Development area six consists of two multi-story residential buildings ranging from three to four stories. The detailed plan estimates that approximately 29 housing units can be established within these two buildings. Upper floors should be accessed via exterior corridors. The module, generated by the tool, has been adjusted to remove six hollow-core slabs to create niches in the facade, along with three half-wall elements. One building unit comprises 184 hollow-core slab elements preserved in their entirety. The proposal incorporates 162 wall elements, including those used in the facade that do not function as load-bearing but stabilising. Of these 162 elements, 69 are retained intact and constitute the vertical support structure. 38 additional hollow-core slabs are utilised to construct the exterior corridors and balconies.

This multi-family housing unit incorporates three apartment types: a large one-bedroom, a small one-bedroom, and a three-bedroom unit. A significant portion of the load-bearing wall elements has been preserved. Instead, small openings have been created in the load-bearing wall elements facilitated by the overhead glulam beam.

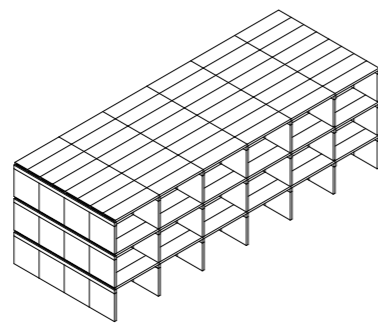

Fig. 29 Axonometric drawing of tool output for the third implementation. Own illustration.

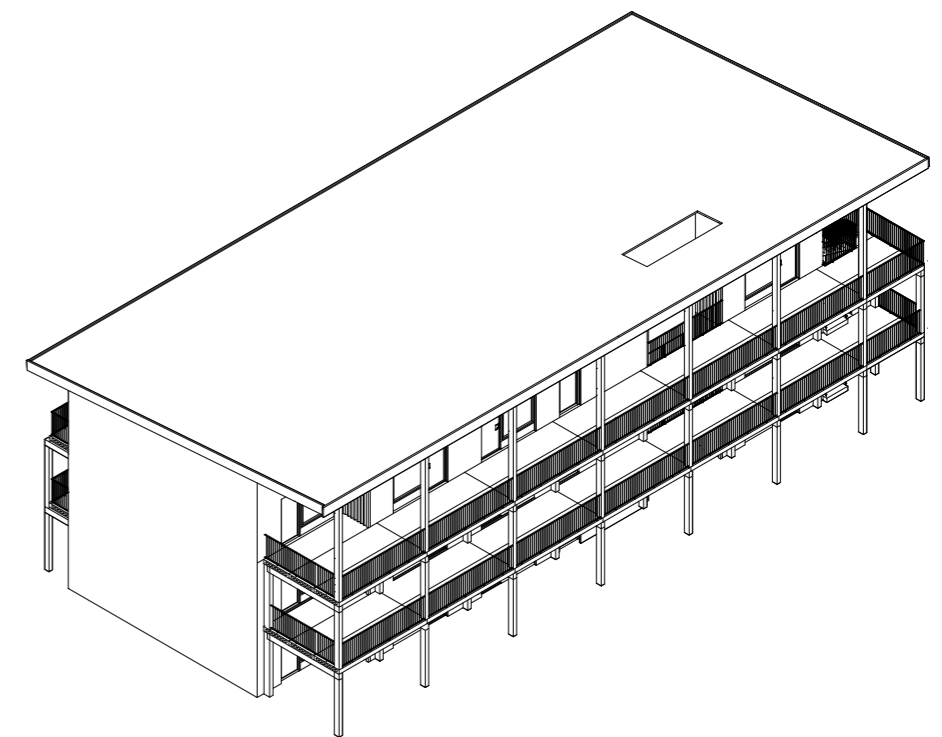
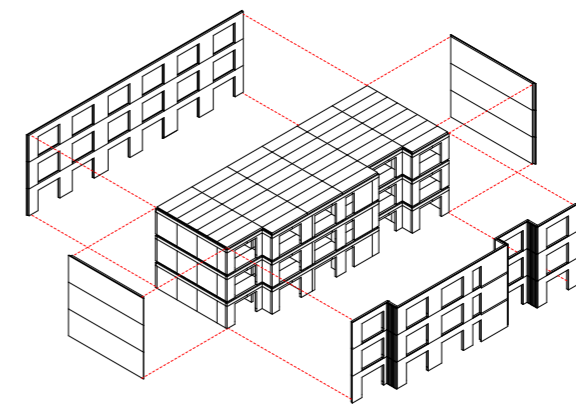
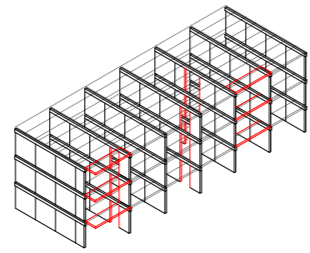
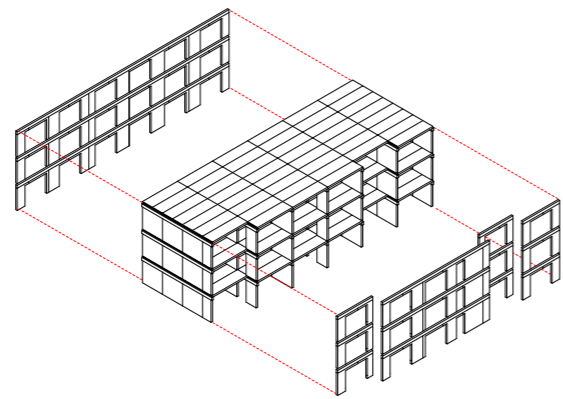

Fig. 30 Axonometric drawing of the third implementation. Own illustration.



1. Wall elements are cut
2. Additional reused concrete walls and new glulam beams are added.
3. Non load bearing frame walls are added.



4. Insulation, rockwool and plaster are added, creating sandwich walls with the reused concrete walls
5. Reused hollow core slabs, insulation, and I-beams on plinths make up the foundation. Roof, doors and windows are added.

Exterior corridor is built from reused hollow core slabs and glulam columns. Hollow core slabs that do not meet quality testing are used as facade elements and partition walls

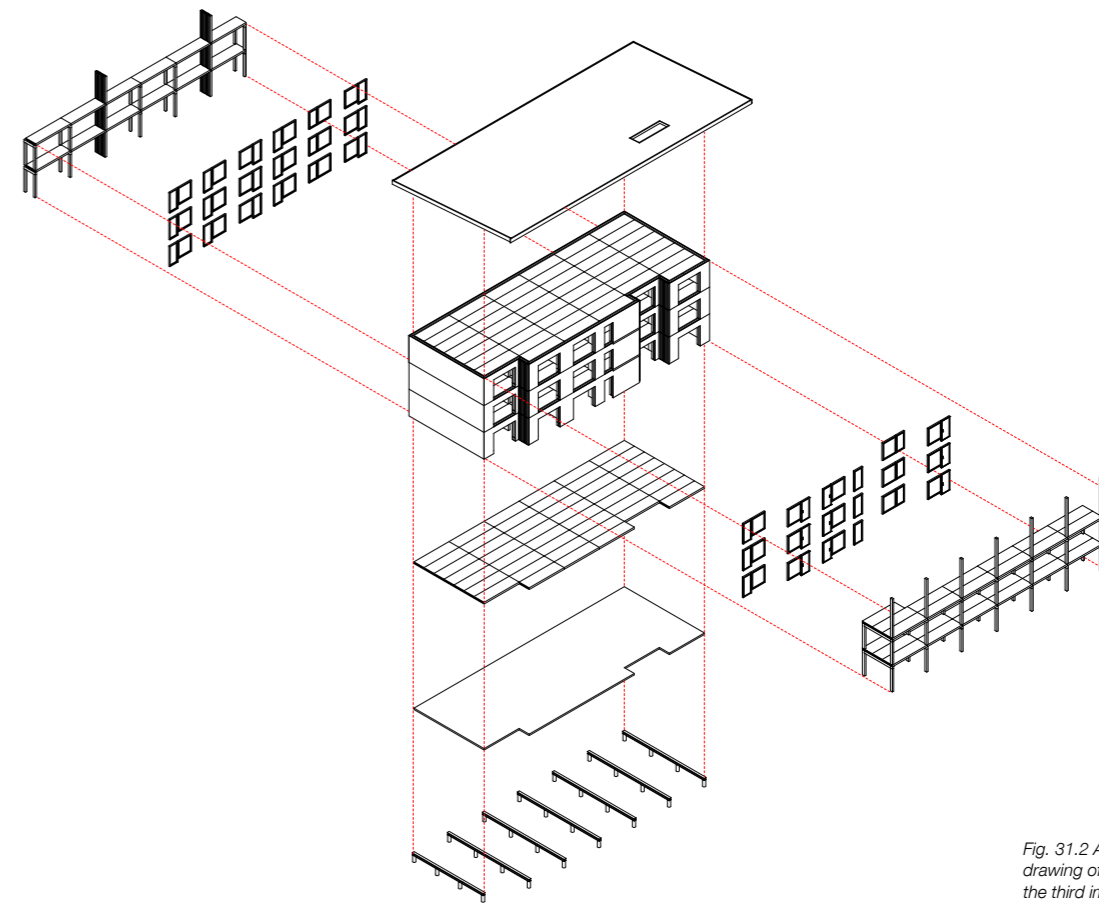
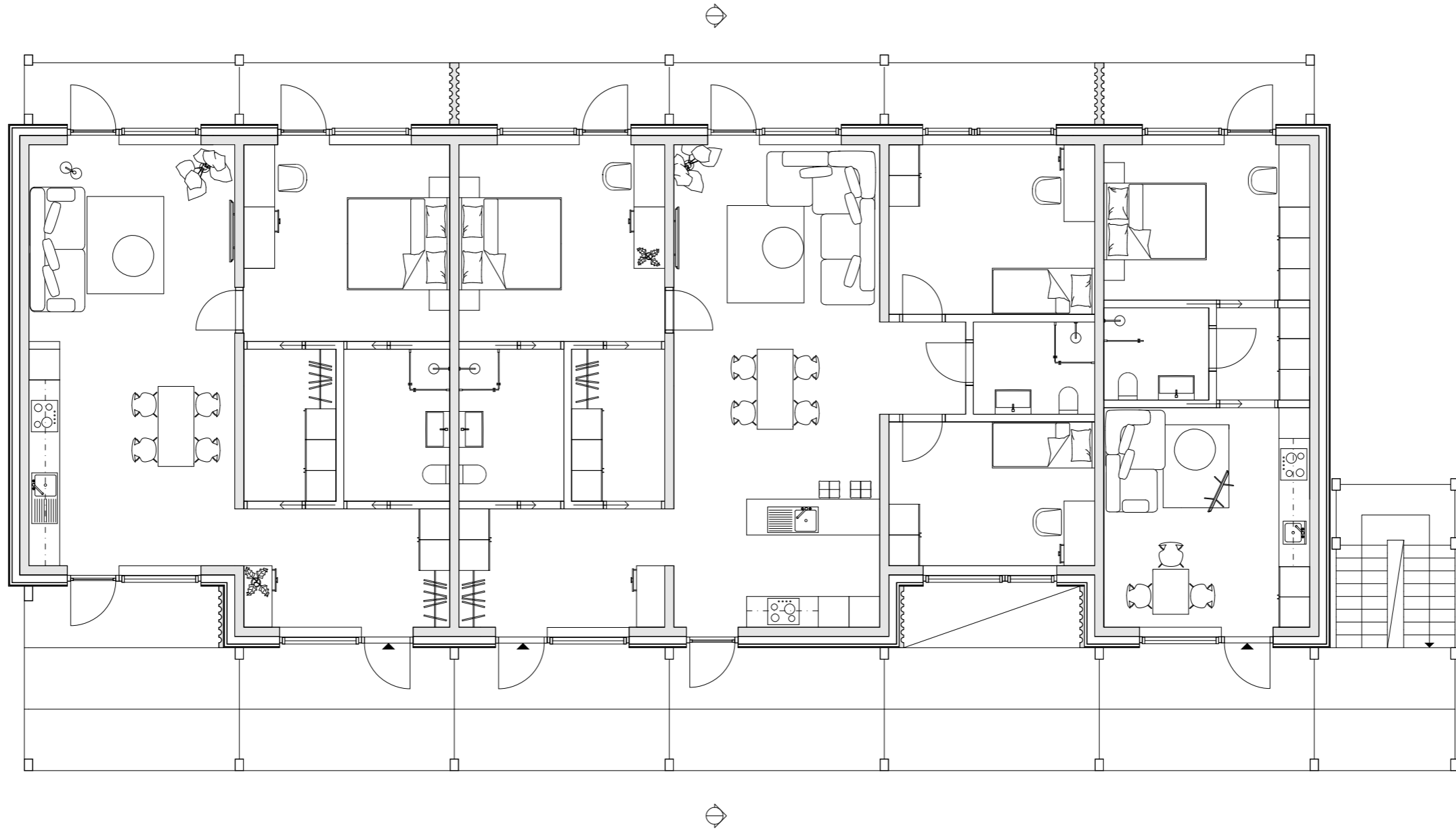

Fig. 31.1 Axonometric drawing of modifications for the third implementation. Own illustration.

Fig. 31.2 Axonometric drawing of modifications for the third implementation. Own illustration.



Plan drawing 1:200



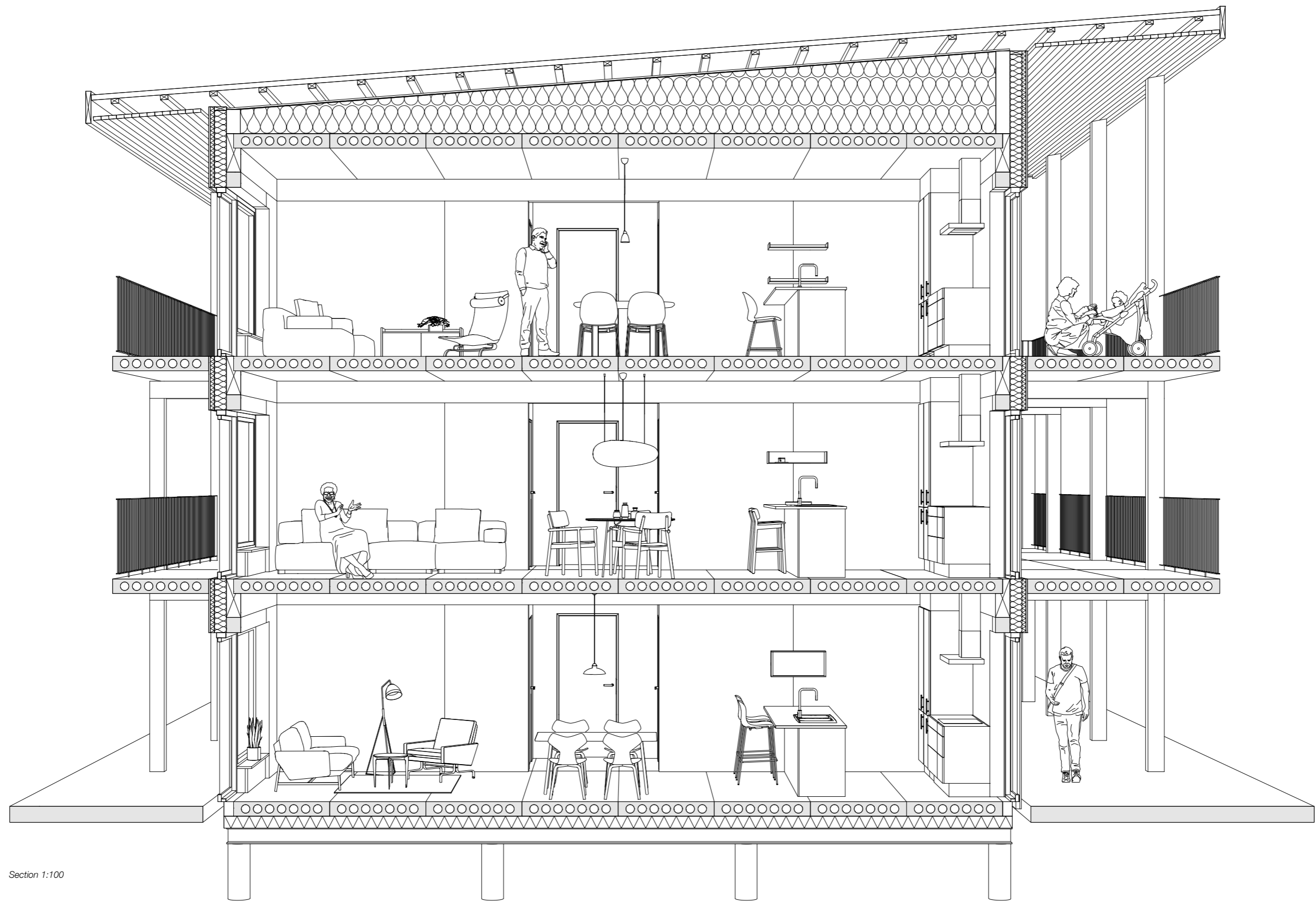

Section 1:100



Fig. 32 Exterior perspective of third implementation. Own illustration.



Fig. 33 Interior perspective of third implementation. Own illustration.

## Discussion

### On the collaborations...

Collaboration with ReCreate and GXN was vital to this master's thesis. The ReCreate team at KTH, including Erik Stenberg, Kjartan Gudmundsson, Helena Westerlind, and José Hernandez Vargas, offered indispensable support through regular tutorials. These sessions deepened the understanding of the reuse process, the characteristics of reused concrete, potential future applications, and crucial discussions on methodologies and implementations. Without their support, the realisation of this thesis would have been substantially more challenging.

The information provided by GXN about the buildings in Gellerup proved essential for this thesis. It served as a fundamental input in the design of the tool. The starting point for developing the tool was an Excel template received from GXN, which identified potential useful data points for the tool's development. This template also functioned as a reference in creating a customised Excel template for integration into the tool, which was subsequently developed in C# for Grasshopper. The support from GXN, specifically from Bjørn-Tore Johannesen and Kåre Stokholm Poulsgaard, was invaluable in this regard.

### On the tool...

Initially, the tool was intended to calculate load-bearing structures based on compressive strength. However, due to the unavailability of this data and the realisation that certain assumptions could be made about the

elements—such as their ability to carry loads they were originally designed for—the tool evolved into a generator for the geometric construction of modules. It also facilitates the transfer of data associated with these elements. Due to the properties of the elements and the tool's programming, the load-bearing modules were limited to their geometry; no angles were facilitated through the tool, thus imposing certain limitations.

This said, the tool offers several advantages. The output generated by the tool serves as a preliminary guide, providing an initial framework for the available elements. This allows for early-stage calculations for CO2 emissions and structural assessments, offering rough estimates for design decision-making. Given that the load-bearing structure is a significant contributor to CO2 emissions, comparing structures made from reused elements with those made from virgin materials could offer valuable insights into the potential benefits.

### On data management...

If a critical perspective is to be adopted, integrating data into Grasshopper via Excel is not optimal. Ideally, one would prefer a database that could manage all data related to the elements more smoothly, facilitating updates and easier integration into the Grasshopper plugin. The data management was hindered by limited time and knowledge. Having completed two courses in computer science, specifically in C# programming and data structures and

algorithms, provided the necessary skills to program the tool. However, knowledge of databases would have been beneficial in potentially incorporating this into the tool.

The scope for exploring data management in this master's thesis was limited. Given more time, a more robust database system would have been developed to manage the elements better. The data chosen to be included in the output—dimensions, coordinates, and kg CO2 per element—was selected to facilitate future management of the structure, primarily for carbon dioxide calculations to compare with similar structures made from new materials. The exclusion of compressive strength from the output was primarily due to structural assumptions made, which initially suggested no need for such calculations.

Ideally, the data included should be guided by regulations or guidelines on what is necessary for enabling reuse, which is outside the scope of this thesis but is acknowledged as an area under investigation and deserving of continued exploration. Notably, neither kg CO2 nor compressive strength data were available during this process, which reduced the motivation to include them in the output. However, selecting which data to include in the output is relatively straightforward, depending on the desired calculations.

### On the implementation...

Implementing the tool was crucial for understanding how the subsequent process would interact with the tool's output. The work on the various proposals primarily focused on how the structure could be modified with minimal changes to enable housing quality. Different implementations presented unique challenges.

The townhouse proposal required the most modifications to the structure; it was the only one of the three proposals where the hollow-core slabs needed to be cut. In all proposals, wall elements had to be cut to facilitate the desired floor plan. The townhouse also posed some technical challenges related to balcony skylights and lateral shifts in the load-bearing line. However, these modifications were feasible, albeit requiring more modifications than the other proposals. For Development Area 3, the approach was to explore a flexible floor plan where larger openings were made in the load-bearing structure. This attempted to challenge the potential floor plans that could be achieved within these strict parameters. Therefore, more wall elements needed to be cut in this proposal than in Development Area Six, where very few modifications to the load-bearing structure were necessary.

In Development Area 6, a large portion of the load-bearing walls was preserved; the most significant modification involved removing hollow-core slabs in the facade to allow for niches. This implementation demonstrated that significant changes could be made to the layout with relatively small means in terms of modifying the structure. This implementation was also developed after working on Development Area 3, which provided familiarity with the modules' dimensions and a better understanding on how to work with them.

Overall, it can be said that apartment buildings are best suited for implementation of the tool, as fewer modifications to the load-bearing structure are necessary. However, this does not preclude using the tool for a townhouse structure, as it can provide initial carbon dioxide calculations comparable to similar structures, even though more modifications may be needed in a later design stage.

**And some general thoughts...**

One of the principal challenges encountered in this project was planning within the constraints of an existing structure. To address this, the inclusion of a glulam beam introduced necessary flexibility, enabling adjustments in level and height and allowing the removal of some load-bearing wall elements. The hybrid between reused concrete and wood should be explored further regarding the architectural qualities they could provide and building technology, looking at critical joints between wood and reused concrete.

Viewing waste materials as valuable resources will become increasingly important as we face future challenges. Implementing this tool exemplifies a shift in perspective, advocating for relocating resources from areas of abundance to those where they are needed.

This project also underscores the need for a broader discussion on transferring values between locations. While the technical and environmental benefits are apparent, it is essential to consider the architectural values and their impact when they are removed or added to a site. Balancing the development of the tool with the architectural aspects of the project meant that some architectural considerations had to be compromised. Hence, the synergy between the existing properties of reused components and the freedom of design presents a fascinating area of exploration. As architects, working with material limitations will be the challenge of our time. This thesis has attempted to explore what such a synergy can look like.

## References

- Brütting, J., Desruelle, J., Senatore, G., & Fivet, C. (2019). Design of Truss Structures Through Reuse. *Structures*, 18, 128-137.
- Çetin, S., Wolf, C. D., & Bocken, N. (2021). *Circular Digital Built Environment: An Emerging Framework*. Basel: MDPI.
- Clifford, B., McGee, W., & Muhonen, M. (2018). *Recovering Cannibalism in Architecture with a Return to Cyclopean Masonry*. Turin: Kim Williams Books.
- Copeland, S., & Bilec, M. (2020). Buildings as material banks using RFDI and building information modeling in a circular economy. *Procedia CIRP*, 90, 143-147.
- Eklund, M., Dahlgren, S., Dagersten, A., & Sundbaum, G. (2003). *The Conditions and Constraints for Using Reused Materials in Building Projects*. CIB Publication.
- Garcia, A. B., Cebeci, Y., Calvo, R. V., & Gordon, M. (2021). *Material Data Intelligence*. Hong Kong: The Association for Computer-Aided Architectural Design Research in Asia (CAADRRIA).
- Gorgolewski, M. (2008). *Designing with reused building components: some challenges*. Toronto: Taylor & Francis.
- Gudmand-Høyer, S. M., Nielsen, T., Olesen, K., Moseng, K., Vestergaard, I., Bach, R. C., & Jensen, B. G. (2021). *Gellerup*. Arkitektens Forlag.
- Guldager Jensen, K., Taron, J., Forward, K., & Pattullo, H. (2019). *Designing out waste*. Calgary.
- Hendriks, C. F., & Janssen, G. M. (2003). *Use of recycled materials in constructions*. Delft: RILEM .
- Heunicke, N. M., Poulsgård, K. S., Smith, K. H., Haukhol, J., Gimmel, K. S., Udbye, K., . . . Eberhardt, L. (2020). *Ressource Blokken*. Copenhagen: GXN Innovation, Teknologisk Institut, SBI, JAJA Architects, Regnestuen.
- Ji, S., Lee, B., & Yi, M. Y. (2021, November). Building life-span prediction for life cycle assessment and life cycle cost using machine learning: A big data approach. *Building and Environment*, 205, 108267.
- Küpfer, C., Bastien-Masse, M., & Fivet, C. (2023, January 10). Reuse of concrete components in new construction projects: Critical review of 77 circular precedents. *Journal of Cleaner Production*, 383, 135235.
- Marinkovi, S. B., Ignjatovi, I., & Radonjanin, V. (2013). *Life-cycle assessment (LCA) of concrete with recycled aggregates (RAs)*. Woodhead Publishing Limited.
- MVFP. (2013, June 16). Global cement production in 1990, 2000 and 2010, with forecasts for 2020 and 2030(in million metric tons). Retrieved September 13, 2023 from Statista: <https://www.statista.com/statistics/373845/global-cement-production-forecast/>
- O'Connor, J. (2004). *Survey on actual service lives for North American buildings*. Vancouver: Forintek Canada Corp.
- Pacheco-Torgal, F., Brito, J. D., Labrincha, J., Tam, V. W., & Ding, Y. (2013). *Handbook of Recycled Concrete and Demolition Waste*. Woodhead Publishing.
- Pakarinen, S., & Huuhka, S. (2021). *Project Handbook for the ReCreate*. The ReCreate project.
- Sigurðardóttir, H. S., Heinonen, J., Ögmundarson, Ó., & Árnadóttir, d. Á. (2023). *Neighborhood-Level LCA and Hotspot Analysis of Embodied Emissions of a New Urban Area in Reykjavík*. Basel: MDPI.
- Sommer, J., & Guldager Jensen, K. (2016). *Building a Circular Future*. Copenhagen. Standard Norge. (2021). *Hollow Core Slabs for Reuse*.
- Tvinn Solutions AS. (2023, September 17). Tvinn Solutions. From Løsninger: <https://www.tvinnsolutions.no/losninger>
- Udbye Christensen, K. (2023, September 17). (P)RECAST. From Danish Technological Institute: <https://www.dti.dk/projects/p-recast/43887>
- United Nations Environment Programme. (2013). *Guidelines for National Waste Management Strategies*.
- Wahlström, M., Castell-Rüdenhausen, M. z., Hradil, P., Smith, K. H., Oberender, A., Ahlm, M., . . . Hansen, J. B. (2019). *Improving quality of construction & demolition waste – Requirements for pre-demolition audit*. Copenhagen: Nordic Council of Ministers.
- Wang, B., Yan, L., Fu, Q., & Kasal, B. (2021, August). *A Comprehensive Review on Recycled Aggregate and Recycled Aggregate Concrete*. Resources, Conservation and Recycling, 171, 105565.
- Yu, Y., Yazan, D. M., Bhoohibhoya, S., & Volker, L. (2021, April 15). *Towards Circular Economy through Industrial Symbiosis in the Dutch construction industry: A case of recycled concrete aggregates*. *Journal of Cleaner Production*, 293, 126083.



