



# naturum

V Å L Å D A L E N

*An architectural investigation on the  
relationship between place, construction & space*

MIKAEL JUNEHAG

CHALMERS SCHOOL OF ARCHITECTURE  
DEPARTMENT OF ARCHITECTURE AND CIVIL ENGINEERING

SUPERVISOR: BJÖRN GROSS  
EXAMINER: MIKAEL EKEGREN

**Naturum Vålådalen**

Mikael Junehag  
Master Thesis 2020

Chalmers School of Architecture  
Department of Architecture and Civil Engineering  
Architecture and Urban Design

Supervisor: Björn Gross  
Examiner: Mikael Ekegren



**CHALMERS**  
UNIVERSITY OF TECHNOLOGY



*Thank you for your invaluable tutoring & support!*

*Ulla Antonsson, Lukas Nordström, Carl Molander (White Architects),  
Björn Gross & Mikael Ekegren,  
family & friends.*

## ABSTRACT

This thesis aims at investigating the relationship between a specific context, construction and architecture, as a way for architecture to relate to and support a narrative and understanding of a place. The main method has been the design of a naturum, a nature and culture visitor centre for a nature reserve. The question was, during the process, broken down into two main questions. How can traditional log framing technique be developed and used in a contemporary architecture? And how can the cultural heritage of the indigenous sami people be reinterpreted in architecture?

The process started off with research followed by a site analysis. The main concept was then developed from an explorative phase where building footprint, volume, functional layout and construction options were being investigated. This was then followed by an iterative design process refining plans, sections, facades and construction details.

The swedish naturum are located all over the country and functions as inspirational and educational gates to the nature. The location is at the entrance to Vålådalen nature reserve, a popular visit goal for hikers. The mountain landscape has a magnificent nature and a long and interesting cultural history. The area has been populated by the indigenous sami people since a long time and reindeer herding is still being conducted in the reserve.

With this thesis I hope to contribute to the current development of contemporary wood architecture and to the architectural discussion of how architecture relates to place. I also hope to contribute to the current processes and plans of future developments of naturum, cultural centers and similar functions in the region of Jämtland and equal contexts.

## TABLE OF CONTENT

<b>Introduction</b>	
About the author	10
Aim	11
Investigative questions	11
Delimitations	12
Method	13
<b>Background</b>	
The Swedish naturum	16
Tectonics in architecture	17
Reference buildings	18
Vålådalen nature reserve	23
Vålådalen village	27
Site analysis	29
Views from the site	30
Village character	31
Space program	34
Design Criteria	36
To visualize an invisible heritage	38
The sami hut	39
Log timber framing tradition	40
Wall type comparison	43
<b>Design proposal</b>	
Design concept	46
Site plan 1:3000	50
Exterior perspective	51
Site plan 1:1000	52
Site section 1:1000	53
<b>Main building</b>	
Plans, sections facades 1:200	54
Facade & detail section 1:40	62
Connecting details 1:10	64
Exterior perspective	66
Interior perspectives	70
<b>Support building</b>	
Plan, section, facades 1:200	74
Interior perspective	77
Physical models	78
<b>Discussion</b>	80
<b>References</b>	83



*introduction*

## ABOUT THE AUTHOR



**Mikael Junehag**

2017

**Bachelor degree, architecture**

Chalmers University of Technology

2017-2018

**Internship Abako arkitektkontor**

Healthcare studio

2018-2020

**Master programme, architecture & urban design**

Sustainable development and the design professions, autumn 2018

Healthcare architecture, autumn 2018

Design systems, spring 2019

Housing inventions, spring 2019

Planning & designing for a local context, autumn 2019

**Other**

Summer course - From idea to built form, summer 2019

Competition - Silent meditation cabin in rural Latvia, 2018

## AIM

The aim is to design a proposal for a new naturum at the gate to Vålådalen Nature Reserve in the county of Jämtland.

## INVESTIGATIVE QUESTIONS

**How can a public building enhance the experience of a local nature reserve and cultural history through the linking of place, construction and space?**

How can traditional timber techniques be used in a modern way?

How can the indigenous sami cultural heritage be reinterpreted into compelling architectural spaces?

## DELIMITATIONS

Today there's a current naturum in Vålådalen housed in a refurbished farm building. There has though earlier been plans on developing a freestanding facility at the proposed site. The arguments for that are presented in the thesis. This thesis is although not about arguing for a new naturum at the location. The thesis should not be read as an investigation on *if* to build a new naturum at the location but rather *how* according to thesis questions. Furthermore credible options like the possibility for extending the current facility, or investigating alternative sites for placement is not part of the investigation.

*Process diagram*

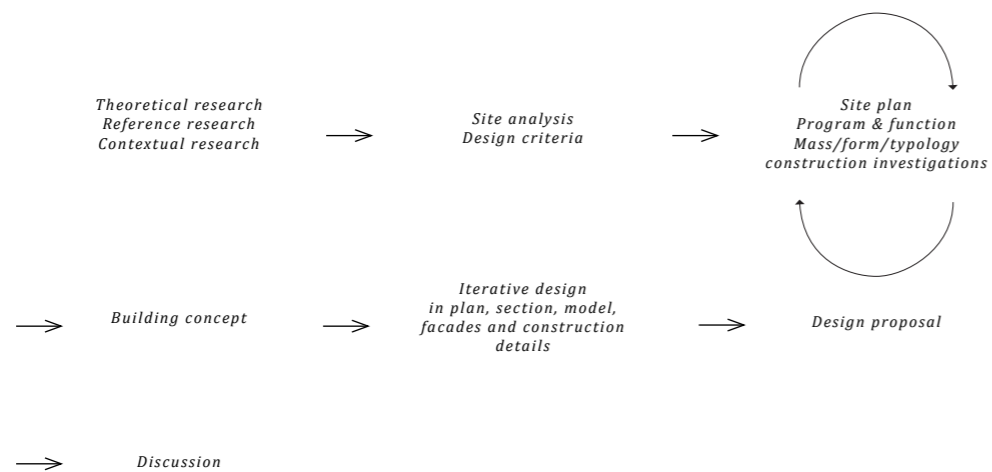

## METHOD

### *Process*

The research has been conducted mainly through a research by design method with the design of a new naturum in the mountain landscapes of Vålådalen in Jämtland county.

A research phase started the process followed by a site analysis and development of program and design criteria. The building concept was then developed from an exploration phase where site, volume, functionality and construction alternatives was being investigated and evaluated.

This was then followed by an iterative design process refining plans, sections, facades and construction details leading to the final design proposal.

### *Collaboration with White Architects*

The thesis has been conducted in collaboration with White architects, an office with a large experience in designing visitor centres. White architects has provided supplementary tutoring through the whole process.



*background*

## THE SWEDISH NATURUM

The Swedish naturum, best translated to visitor centres, are located all over the country and function as inspirational gates to the nature. Here visitors can learn more about the nature and cultural history of a particular area, often national parks or well visited nature reserves. It is the Swedish Environmental Protection Agency (EPA), in Swedish, *Naturvårdsverket*, who owns the right to the name, but the visitor centres are most often run by a county administrative board, municipality or a foundation (Naturvårdsverket, 2019).

The naturum are EPA's most important tool to increase knowledge about the Swedish nature and environment. Its architecture has therefore been considered as an important part in this. Since 1986 and the building of Naturum Hornborgarsjön, the agency has tried to place a great emphasis on the architecture in the development of new facilities.

A lot of naturum attracts visitors through their unique architecture, and some of them have been nominated to fine architecture prizes (Lauri, T, et al., 2013).

There are in total 33 naturum in Sweden. In Vålådalen, an existing naturum is located in an old village building, but there has earlier been plans on developing a new and more freestanding naturum more clearly connected to the nature reserve (P.O. Eriksson, Länsstyrelsen, Östersund, 191028).



## TECTONICS IN ARCHITECTURE

Researching different naturum in Sweden I realized that some of the newer examples had been criticised for lacking a tectonic connection to their contexts, that local materials were only used as something were added on to the surface at the end and that ideas about how the form language related to the place were often quite abstract.

This led to the thesis question and the intention to design something that has a stronger tectonic connection to the context and a form language that in a more direct and sensible way could connect to the narrative of the place.

In *Towards an Ecology of Tectonics*, Madsen argues that modern building industry has been developed into something that can be described as paradox of autonomous interdependent systems which are largely dictated by global trends and economy. (Beim & S. Madsen 2014). As a result, it has been increasingly difficult to maintain regional and cultural identities in the built structure. Contemporary architecture can in its worst cases be described as half hearted collages that doesn't relate or depend to either local resources or craft traditions.

A tectonic approach, as a principle for architectural design could be a respond to this as it strives to tell the story of its own making, refer to its context and embedded meaning (Beim & S. Madsen 2014). The core of a tectonic thinking is about creating a link between matter and meaning.

The Italian architectural theorist Marco Frescari claimed that the concepts of the "construction" and the "construed" has to be united in order to give significance to architecture. It could be argued to be of great importance in creating a durable architecture, forming a resistance to shifting styles determined either by economic interests, building regulations or soon to be outdated architectural trends. A tectonic approach to architecture strives to identify a basic starting point for architectural creation, directing its focus to the basic building blocks of architecture. In the case for this project, that building block became the log timber.

## REFERENCE BUILDINGS

### **Haus Annalisa**

Peter Zumthor

An important inspiration has been Haus Annalisa where Peter Zumthor worked with the reinvention of the traditional swiss log timber cabin. In doing this he and his team first developed a set of rules based on the properties of the crosstimmer construction technique in a way that they were able to adapt the traditional technique to modern life and add large window openings which would have been impossible in a traditional log timber buildings.

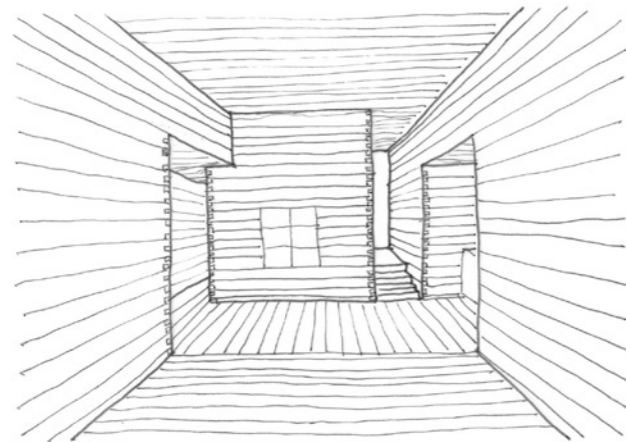
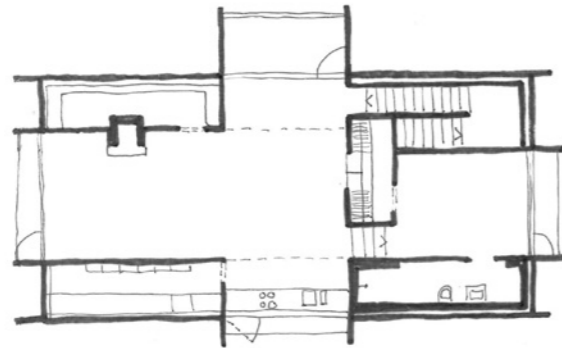

### **Stiva de morts**

Gion A Caminada

Stiva de morts by the swiss architect Caminada has a double massive cross timber construction. For Caminada construction is not just about functionality. Even though the construction in this and other buildings he has been working with could have been done more rationally with modern construction methods the use of the traditional log timber technique is according to Camina a way to create value as it give jobs to the local community and enhances a local cultural heritage.

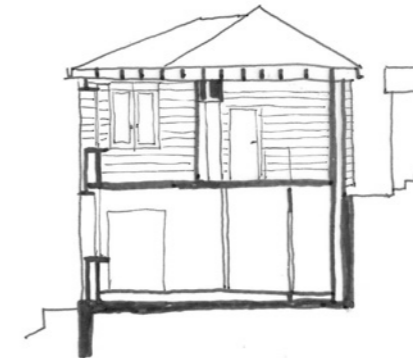

**Weekend house Roslagen**  
Gustav Appell arkitektkontor

In Gustav Appells weekend house a similar approach as in House Annalisa was used. Through breaking the building up in smaller boxes, larger parts of windows were possible and a continuous more open space is shaped in between the boxes.

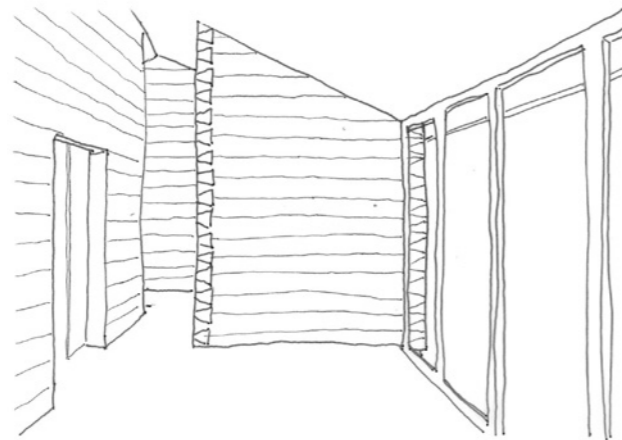
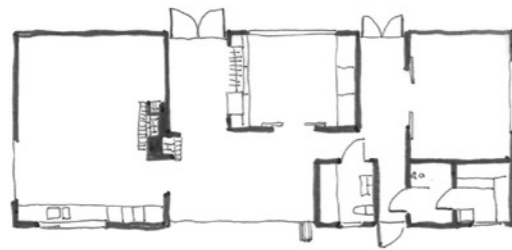

**Visitor Centre Preston**  
Adam Khan architects

Visitor centre Preston became the main reference & inspiration for the roof construction.

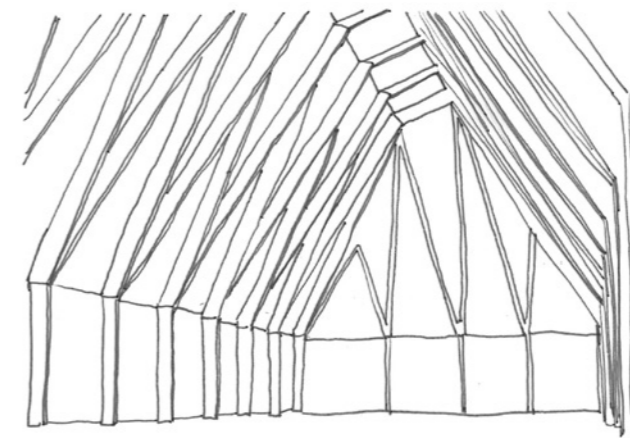
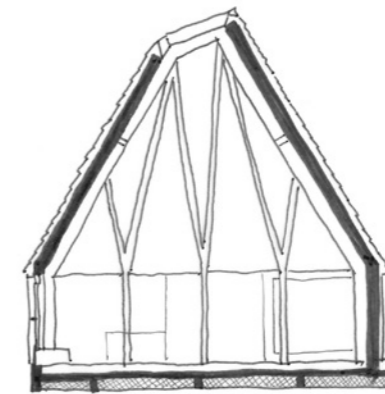

## VÅLÅDALEN NATURE RESERVE



### *Nature reserve*

Vålådalen reserve is a 1175 square kilometer large area in the mountain landscapes of Åre municipality in the western parts of Jämtland (Länsstyrelsen, Jämtlands Län, 2020). The landscape is characterized by its mountains and large forests, marshes, shiny lakes and flowing waters. The nature reserve is easy to reach and has many visitors every year. Vålådalen village is the starting point of a numerous both longer and shorter hiking tracks in and around the area.

### *Sami land*

Vålådalen has a long history of reindeer herding. In the landscape there are many traces of the life and work of the indigenous Sami culture. Reindeer husbandry is still conducted in the area and plays a vital role in the preservation of the characteristic open landscape. There are two sami communities that extends into the reserve, Handölsdalen and Tåssåsen. A sami community consists of a number of sami companies sharing a large area for reindeer grazing.

### *Log timber tradition*

The region of Jämtland is a part of Sweden that always have had good access to coniferous trees which is connected to a strong log construction building culture with long traditional roots. The technique was a bit forgotten during the first part of the 20th century but regained in popularity towards the end of the century, especially for holiday homes. This particularly in the mountain landscapes due to the expansion of tourism. As a result, there's a number of log construction companies in the region and close to the the reserve, carrying the tradition on.

*Vålådalen, situated in the mountain landscapes of Jämtland*

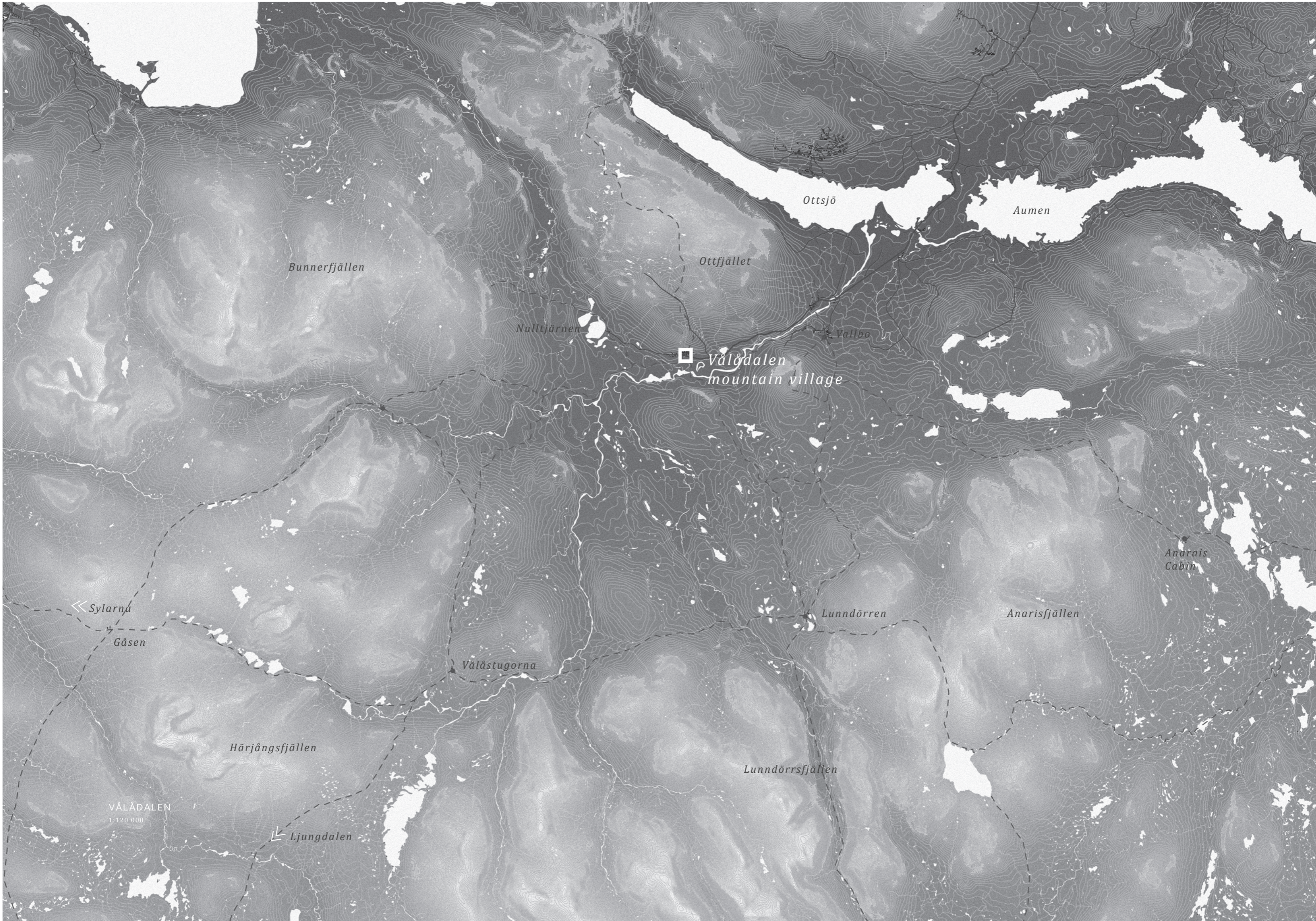

Ottsjö

Aumen

Bunnerfjällen

Ottfjället

Nulltjärnen

Vålådalen  
mountain village

Vallbo

Anarais  
Cabin

Anarisfjällen

Lunndörren

Lunndörrens fjällen

Vålåstugorna

Härjångsfjällen

Ljungdalen

Sylarna

Gåsen

VÅLÅDALEN  
1:120 000

## VÅLÅDALEN VILLAGE

### *History*

The small mountain village in Vålådalen is mainly a tourism and leisure village organized around the Vålådalen mountain station, a tourism facility inaugurated in 1923 (ne, 2020). Connected to the mountain station there is a ski slope and cross country ski trails. In addition to the station which includes a hotel and restaurant a number of villas and holiday homes has been built over the years.

There has although been people in Vålådalen long before the first tourists came to the mountains. Traces of human activity goes back to the iron age while the sami population has been conducting reindeer herding at least since the 17th century. The first settlers came in 1830 and the main trace of this can be seen in for the time so typical double floor farmhouse, built in the shift between 19 & 20th century where the current naturum is facilitated (Vålådalens Fjällstation, 2020).

### *Proposed placement*

The proposed placement of the new naturum will make it more visible as you arrive to the area and get a more natural placement between the parking lots and the entrance to the reserve as well as strengthening it as a gate to nature.

- |   |  |
|---|--|
| 1. <i>Direction of arrival</i>                            | 5. <i>Current naturum facility</i>         |
| 2. <i>Parking lot</i>                                     | 6. <i>Vålådalen mountain station</i>       |
| 3. <i>Proposed placement</i>                              | 7. <i>Ski slopes &amp; main ski trails</i> |
| 4. <i>Entrance to trekking paths &amp; nature reserve</i> |  |



SITE PLAN (CURRENT STATE)  
1:3000

## SITE ANALYSIS

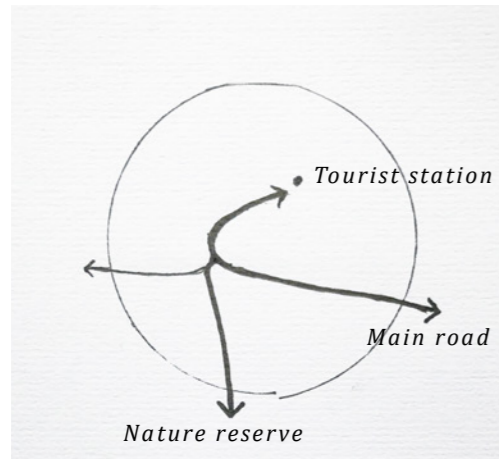

MAIN FLOWS

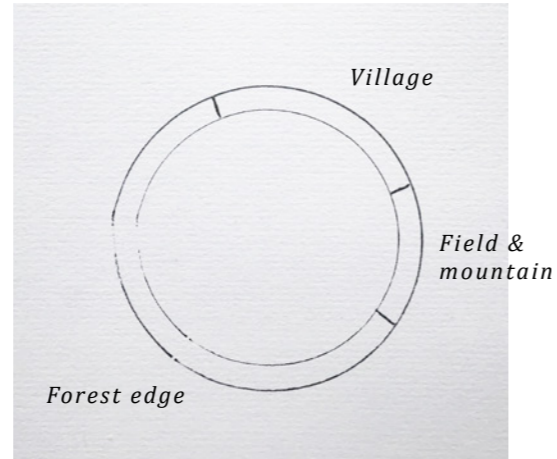

VIEWS

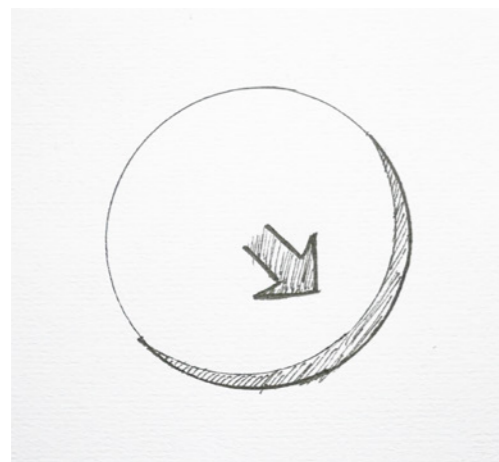

MAIN HARSH WIND "NORDVÄSTAN"

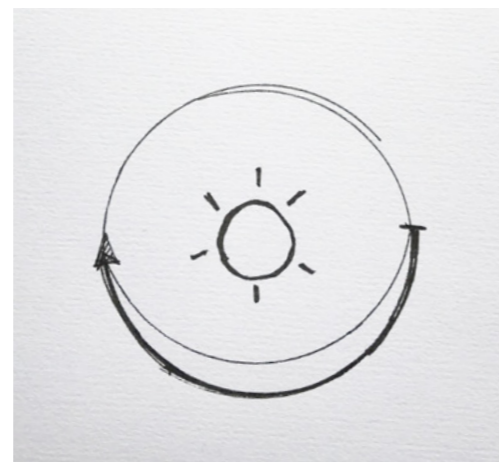

SUN PATH

The main flows are between main road, the village center and the nature gate. An axis in north-south direction is connecting the entrance, parking lot and village. Traditionally entrances are turned to the east in this area due to the direction of "nordvästan", a particularly harsh wind from the north-east direction.

The nature views from the site are not grandiose but to the east there is a nice view over a mountain top and the adjacent forest edge creates a presence of nature.

A challenge with the site is that you would arrive to the building from the north, the shady side.

The buildings are laid out in two or maybe three main directions that can be seen in the pattern of building footprints. The structure is a combination of creating an order and adapting to the hilly terrain.



BUILT STRUCTURE

## VIEWS FROM THE SITE



**View to the north**  
*Mountain village and ski slope*



**View to the east**  
*"Middagsvålen" mountain top*



**View to the south**  
*Entrance to trekking paths*



**View to the west**  
*Forest edge*

## VILLAGE CHARACTER

The buildings of the village consists of tourism facilities, some historical crosstimmer typologies that some of them are used as hotel rooms and a couple of farm buildings. A majority of the buildings are painted in falu red paint, but here and there you find buildings that either has a naturally grained wood panel or are painted in dark brown.

The log timber are visible primarily in the smaller huts and support buildings. Traditionally it has been more common to leave the construction visible in less important support buildings while main buildings were covered with a vertical panel on top of the construction which is the case for "Möllers gård" and the mountain station. For new built cross timber building such as holiday homes it's more common nowadays to make the logs as visible as possible.





*The mountain station*



*"Möllers gård" - farm house that houses the current naturum*



## SPACE PROGRAM

The current Naturum in Vålådalen is crammed in to an old building but would need more space. Based on reference projects, mainly naturum in similar size , own reflections and discussing a hypothetical scenario for a new building with Ola Fransson (191109 and 200201), manager at the current facility, I've based the space program.

The current building is not accessible as there are exhibition spaces on the second level of the building but no elevator.

There's a large need for more staff area as there's next to none of this in the current building. The exhibitions take up most of the space which leaves the working environment in a very poor condition, a situation that impedes the continuous pedagogic development. There's also a wish for a workshop where material for the exhibitions, both inside and outside of the Naturum could be produced or repaired.

As large groups arrive to the facility, they usually gather them outside. Sometimes it can be difficult to be heard if you're talking to a large number of people if its windy. herefor I decided to include a gathering space in the program which is weather protected but not heated.

<b>FUNCTION</b>	<b>AREA</b>
Windbreak	8 m <sup>2</sup>
Wardrobe	10 m <sup>2</sup>
RWC	5 m <sup>2</sup>
WC	3 m <sup>2</sup>
Reception/Gift Shop	15 m <sup>2</sup>
Shop storage	5 m <sup>2</sup>
Lobby	30 m <sup>2</sup>
Library	40 m <sup>2</sup>
Temporary exhibition	35 m <sup>2</sup>
Exhibition spaces	150 m <sup>2</sup>
Lecture hall 30 ppl/50ppl	45 m <sup>2</sup> /70 m <sup>2</sup>
Office 2 ppl	15 m <sup>2</sup>
Staff dining & pentry	12 m <sup>2</sup>
Staff Wardrobe/Changing room	6 m <sup>2</sup>
Staff WC/Shower	5 m <sup>2</sup>
Cleaning storage	6 m <sup>2</sup>
Storages	15 m <sup>2</sup>
Electricity	5 m <sup>2</sup>
Workshop/Maker Space	30 m <sup>2</sup>
Technical spaces	20 m <sup>2</sup>
<b>Total</b>	<b>485 m<sup>2</sup></b>
Gathering space	50 m <sup>2</sup>
Garbage room	6 m <sup>2</sup>
RWC & WC	8 m <sup>2</sup>
Cold storage	20 m <sup>2</sup>
<b>Total</b>	<b>84 m<sup>2</sup></b>

## DESIGN CRITERIA

As a support for the design process, a design criteria was developed. As base for this the guidelines for development of Naturum (Naturvårdsverket, 2015) was studied and also the study of the program and jury verdict for the competition for Naturum Laponia (Sveriges Arkitekter, 2009), as it has a similar context as Vålådalen reserve. This together with the study of Vålådalens unique context brought the basis for design criteria, which can be seen as distilled aim of what besides the thesis questions has guided the design.

### *Function*

The goal for a visit to the area is in this case not the naturum itself, but rather the nature it represents. In the case for Vålådalen, where there already is a lot of visitors every year, the goal is not necessarily to attract more people to visit but rather to spark interest and curiosity for a deeper learning for the reserves nature and culture for the many visitors.

The space should be dimensioned with in mind that the number of visitors in the building might vary a lot. This means that the spaces shouldn't feel desolated if there are few visitors but at the same time doesn't feel crowded if there would come a busload of people entering at the same time.

The staff has a central function in a naturum. The premises should be designed and adapted for both meeting the visitor and the needs of the staff.

### *Expression/atmosphere*

The building needs so spark a curiosity, as it competing with a lot of other joyful activities in the area, to be able to attract not just the dedicated nature enthusiasts but also the broader audience/common ski tourist.

As the building will be placed in a landscape that will be experienced both from afar as well as closed by the building should be appealing both as a sculpture in the landscape but as well as in the details as you get closer. An expectation is growing as you get closer and closer to the building.

The expression of the building should reflect the nature and culture of the reserve in its form, materiality and appearance.

The reindeer herding and sami cultural heritage is very important in the context of the reserve. The goal is therefore a building that can enhance and visualize this cultural heritage at the same time as it adapts to the village context of settler buildings and tourism facilities.

The environment, both inside and outside should be peaceful yet stimulating. A certain spatial complexity gives a more interesting building to move through at the same time as the functions must be able to be housed in a good way.

With the new placement of the building, the facility will be more visible and natural to enter either on the way to the reserve or on the way back from it. Entrance needs to be welcoming & the outdoor space is important for the centre's activities.

### *Construction*

The construction of the naturum should to the greatest extent possible be able to be performed by local actors and craftsmen, and not only relate to the context on a superficial level but be rooted in a deeper tectonic sense through the use of local traditional building techniques.

## TO VISUALIZE AN INVISIBLE HERITAGE

A big question has been how to relate to the built structure of the village. Because instinctively you would just build upon the quite homogenous character visible in the village. But as I learned more about the history of the reserve and visited the current facility I experienced a discrepancy between the content and story represented in the naturum and the building which is a very typical farm building from 19th century in the rural areas of the lower parts of the county, thereby a typology you normally associate with a completely different type of landscape.

I also realized that the the environmental protection agency and the regional council are working a lot with how to make visitors aware of the sami cultural heritage. A common misconception about these mountains is that it is being conceived as wilderness, when it is actually a cultural land. That's not strange though, as an untrained eye would miss a lot of the traces of human activities that are left in the nature. So that led to the second main question - could it be possible to make the building announce the presence of the sami cultural heritage in the building some way? Could it be made in a compelling way that sparks curiosity?

In the village there is a tourism sauna that has been influenced by the sami building tradition. Basically a sami hut typology and a traditional log building has been joined together resulting in a not maybe so appealing design, but in a way also maybe a building that reveals a lot about the history of Vålådalen. In a way, you could say that it is a symbol for the cultural clash which is defining a lot of the history of the region. Similar to this building, it became for me a question of finding a way to relate to different parts of the cultural context, both visible and invisible, as a way to reinterpret it into design. In contrary to the sauna, the intention was thought to find a more appealing and cohesive result.



## THE SOUTH SAMI HUT

The Sami cultural heritage is both material and intangible. It includes landscapes, buildings and other cultural environments as well as objects stories, art and craft culture. Today the samis aren't living as nomads no more, but the sami hut has an important place in the cultural heritage.

The sami huts have been constructed in different ways, but in its traditional design has a hearth in the middle and above that an open smoke hole. The south sami hut typology has the characteristic structure of a sami hut but is built with craft techniques that are more generally common in the context, with a massive crosstimber foundation and shingle covered filigree roof construction. I found it very inspiring with the clear division between massive and filigree in this typology, why it became an inspiration and a way to combine the two thesis questions.

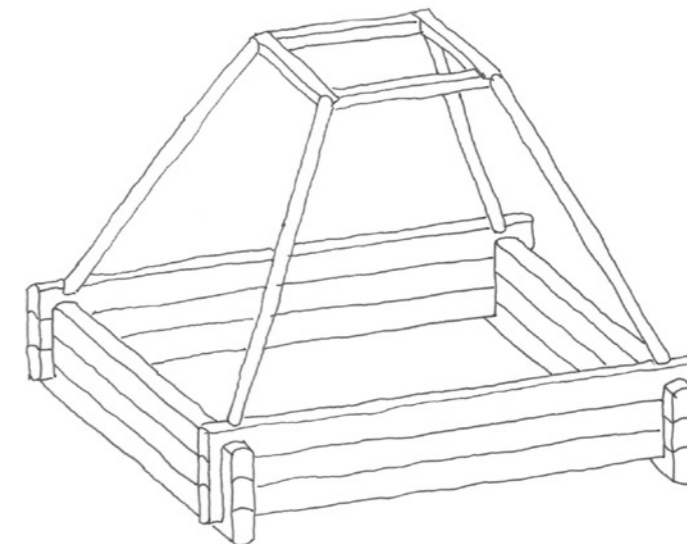

CONSTRUCTION OF SOUTH SAMI HUT

## LOG TIMBER FRAMING TRADITION

In the landscape of Jämtland, as part of the nordic green belt where access to coniferous wood always has been good, the log timber tradition has deep roots in the building culture tradition. There are a number of local companies constructing cross timber houses, as well as craftsmen working with restoration of old log houses. The long tradition has developed into many different techniques and typologies. Some main principles are important in any log construction.

Log timber walls have the benefit that they can level moisture levels and thereby create a more healthy indoor climate. The heat storing capacity of massive wood is best used if the timber is exposed on the inside. Conifer trees soft properties are favorable as the construction then is able to settle. Best material is pinewood that has been able to grow in dry earth (Håkansson, 2017). Raw material up to 8 meters is easy to obtain. For longer walls there are different types of techniques for joining logs together.

For a stable construction, openings are few and evenly distributed, preferably wide rather than high. Dowels are mounted every 2.5 meters to stabilize the construction. Dowels are also added at corners where the wall is not stabilized by knots, such as in window openings.

Log timber constructions are moving. The construction can sag up to three centimeters per height meter. How much depends on how dry the timber is. All windows, doors and other fixed elements therefore needs to be mounted in a way that they don't prevent the structure to sink & expand, which otherwise result in cracks and a less airtight building. A house that has been manufactured correctly over time becomes increasingly more windproof and thereby more energy efficient (Håkansson, 2017).

Central in the technique are the knots. Different types of knots have evolved through time and place. The development have moved from round knotheads to hexagonal and lastly to vertical knot heads and dovetail finger joint, (laxknut). The dovetail finger joint is very common on buildings from the 19th century and is seen as a more sophisticated type of knot.

Traditionally log buildings were uninsulated. Today, that can be a challenge

due to higher energy demands why insulating the walls would probably be difficult to avoid in this type of building. You can chose to insulate either on the inside, outside, or between a double wall construction. Although it's probably the most complicated and costly solution I ended up choosing the latter with insulation in the middle as it is maintaining all the tactile and visual properties of the log wall. This type of wall is not very common so I thought it also would hypothetically add something new to the log construction tradition of the region, broadening the span of construction possibilities to accommodate the energy demands.

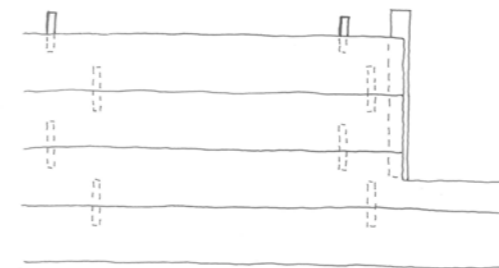

DOWELS IN WALL

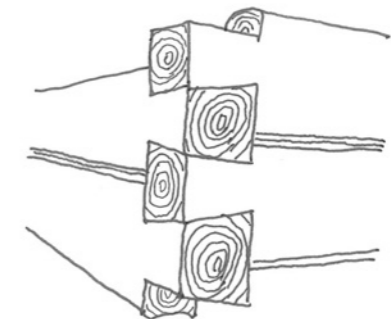

DOVETAIL FINGER JOINT

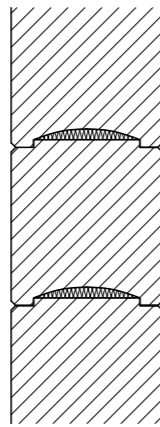

TRADITIONALLY UNINSULATED LOG TIMBER WALL

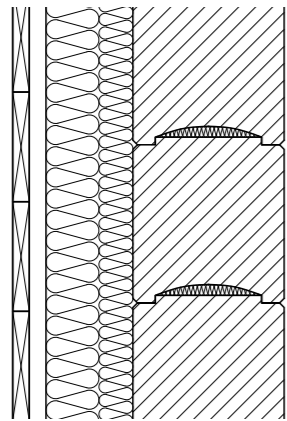

A. LOG TIMBER WALL + INSULATION ON INSIDE

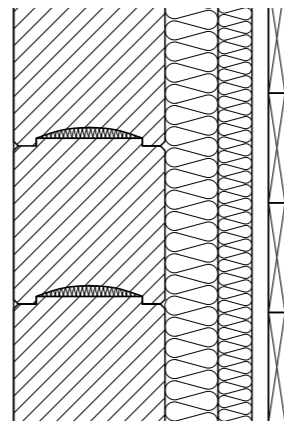

B. LOG TIMBER WALL + INSULATION ON OUTSIDE

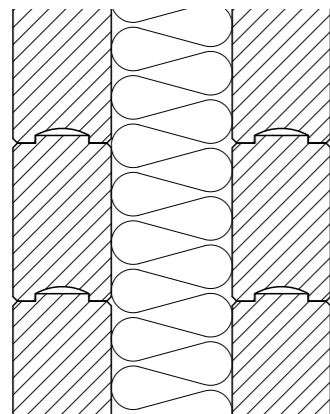

C. DOUBLE LOG TIMBER WALL, INSULATION BETWEEN

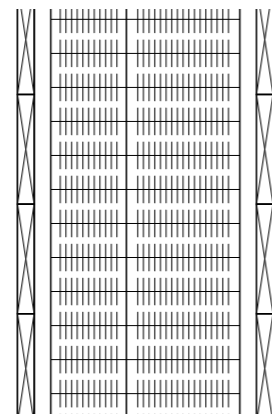

D. ISOTIMBER WITH SURFACE PANEL

## WALL TYPE COMPARISON

Parameter	A.	B.	C.	D.
Regional craft tradition	Yes, but more common with insulation on outside	Yes	Crosstimer construction yes, but double wall is less common	Regional invention, connect to cross timber heritage through the fact that it's wood & it's massive
Tectonic readability	Average	Average	High	Low/average
Sense of mass /robustness	Average	Average	High	Average
Constructive freedom	Limited	Limited	Limited	High
Technical installations	Easy	Challenging	Challenging	Challenging
Reflection	More fragile to moisture & challenging roof connection. A solution more common for adding insulation on existing buildings.	Solution is very common in the building culture and is probably the most reasonable solution of the cross timber alternatives	A development of crosstimer construction that keeps all of its lovely properties but could be challenging & costly to construct.	The regional connection makes it highly interesting but although connected on an esthetic level you lose the actual craft culture



*design proposal*

## DESIGN CONCEPT

The program is divided in two buildings, one isolated and nonisolated. The main building with its extended footprint bonds to the rhythm and pattern of the north-south oriented village buildings and strengthening the movement between parking lot and nature as it lays alongside the walk to the nature entrance.

In the second smaller support building the staff can gather a large group of visitors around a fire as they arrive to the center as well as it works as a wind shelter for passing hikers. This building is more directly relatable to the sami hut.

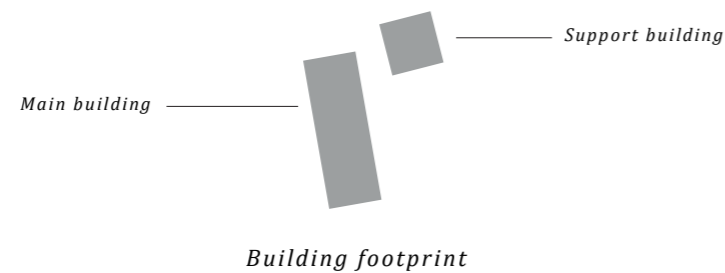

Although the buildings have a similar plan configuration and expression, they reveal a diversity of spatial experiences as you enter and move through the facility.

The two buildings are shaping a yard space that opens up to the south and grand view to the east.

At the same time the yard and main entrances gets a little closed of from the wind from north west.

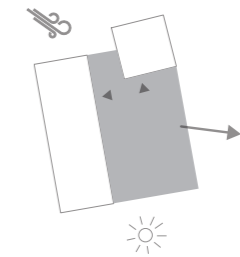

*Yard space*

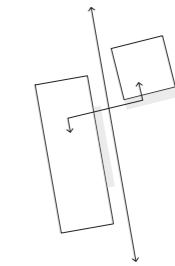

*Main flows*

The communication between-village, parking and entrance to the reserve goes through the yard. The centre becomes a natural gathering point and visiting the reserve is easy to combine with a visit to the naturum.

The volumes are divided into log timbered "boxes" that holds the support and staff functions. Between the composition of boxes a continuous public space is shaped.

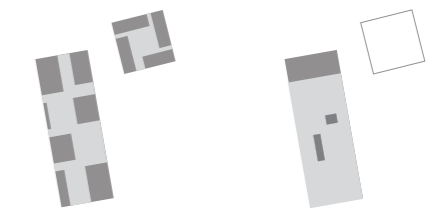

*Public countinuous space*

The second floor is contrasting to the first as it's made up of one large space holding the permanent exhibition and lecture hall, creating a rich spatial experience.

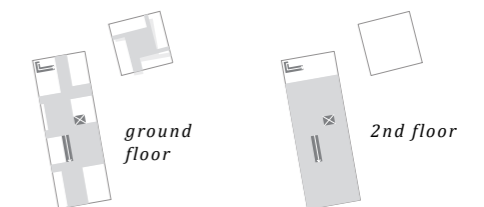

*Vertical communication*

## DESIGN CONCEPT

Between the log timbered boxes larger parts of windows can be installed creating a log building that in contrast to the traditional one can bring in a lot of light and give a greater contact between inside and surrounding nature. It's fairly easy to get hold on logs up to 8 meters, which set the limit to the size of the boxes.

Inspired by the south sami hut and its clear division between massive walls and filigree roof construction the roof is constructed by a framework truss. The truss makes the construction stiff so its able to carry the loads over larger openings, in that sense working as a large beam. At the same time the construction enables a large continuous space on the second floor that contrasts to the more maze like configuration of the first floor.

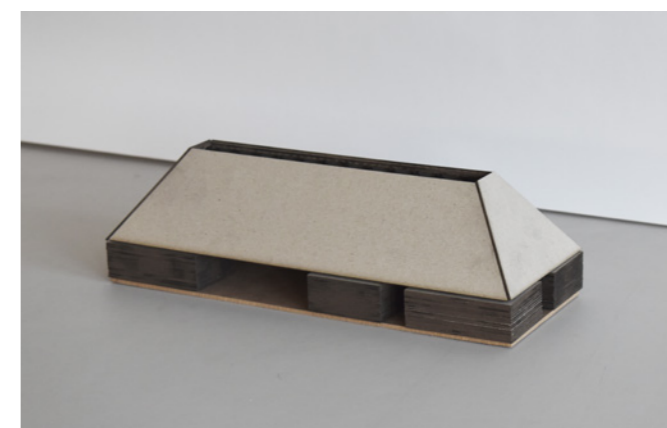

CONCEPT MODEL

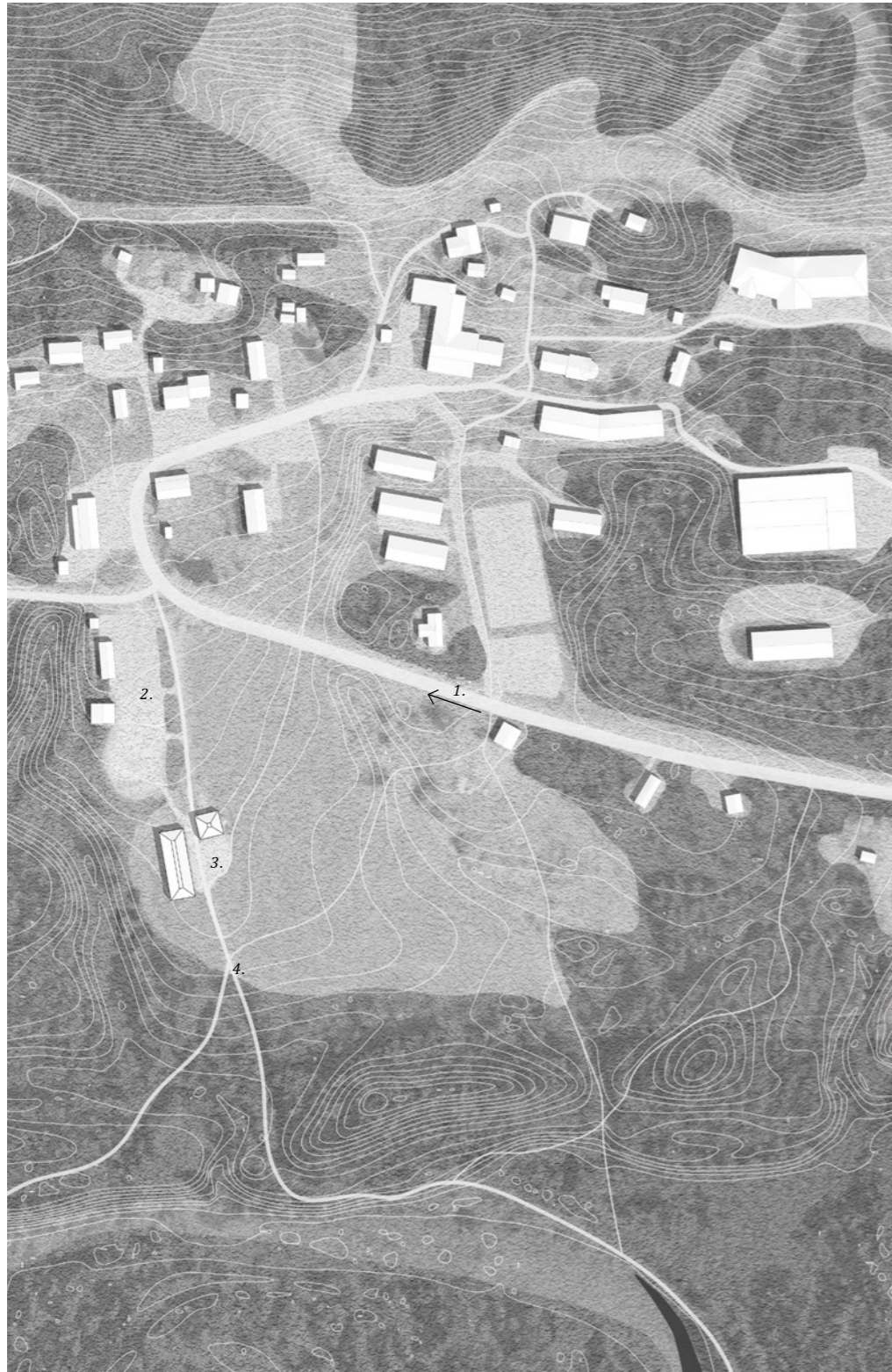

SITE PLAN  
1:3000



- 1. Direction of arrival
- 2. Parking lot
- 3. Proposed building
- 4. Entrance to trekking paths



*First sight of the visitor centre as you arrive on the road*

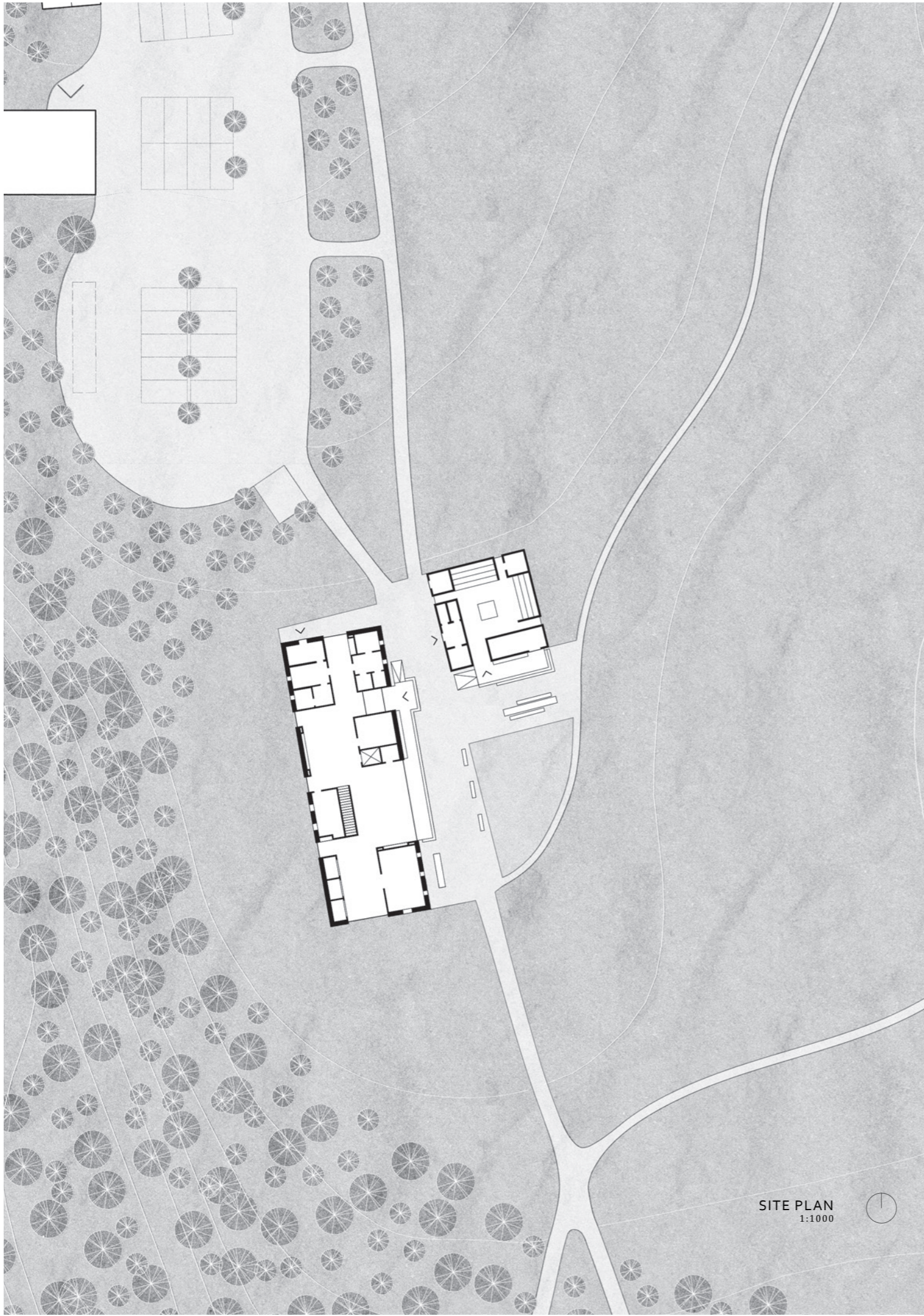

# MAIN BUILDING

- 1. Wardrobe
- 2. Cleaning storage
- 3. Restroom
- 4. Emergency exit
- 5. Staff pentry
- 6. Staff wardrobe & wc
- 7. Reception/Gift Shop
- 8. Office 2 ppl
- 9. Exhibition stands
- 10. Temporary exhibition
- 11. Workshop/Maker Space
- 12. Library
- 13. Storage
- 14. Tech space

- 15. Exhibition space
- 16. Lecture hall
- 17. Storage
- 18. Emergency exit

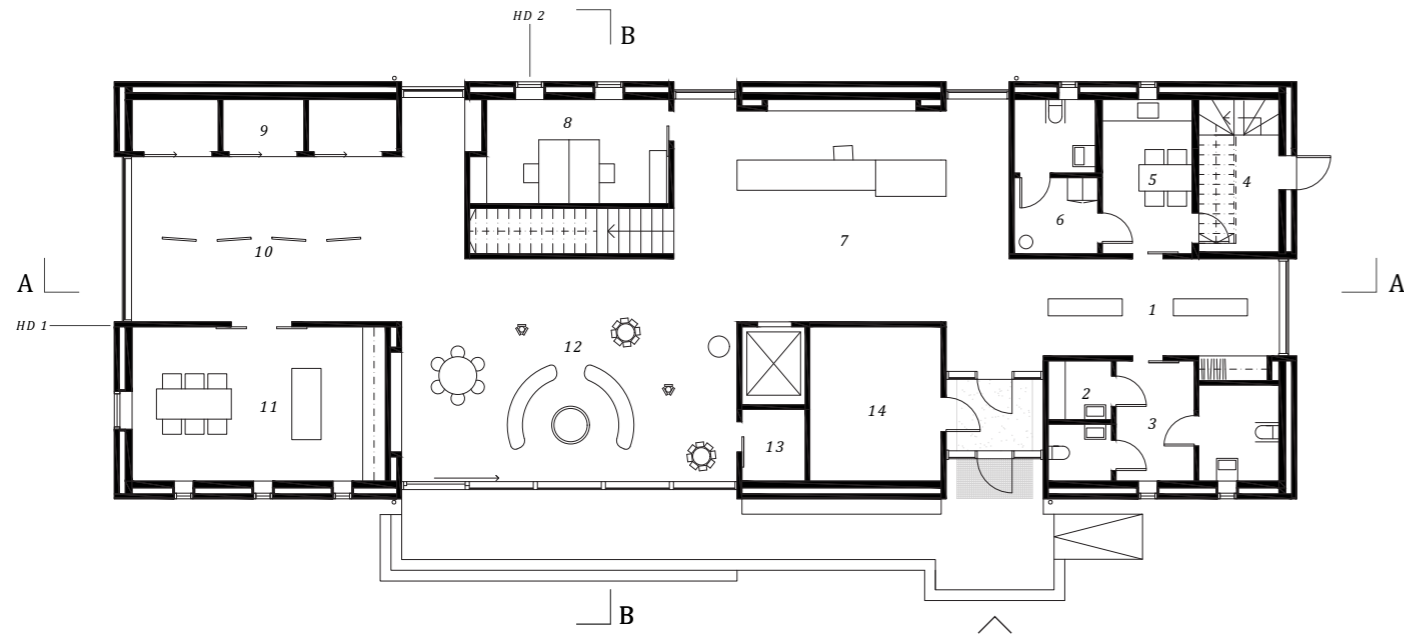

LEVEL ONE  
1:200



*The composition of closed log timbered boxes are shaping an open continuous space in between with views to different directions as you move through the space. Openings into the boxes are limited. Sliding doors are mounted on the inside of the boxes to reduce their visual impact.*

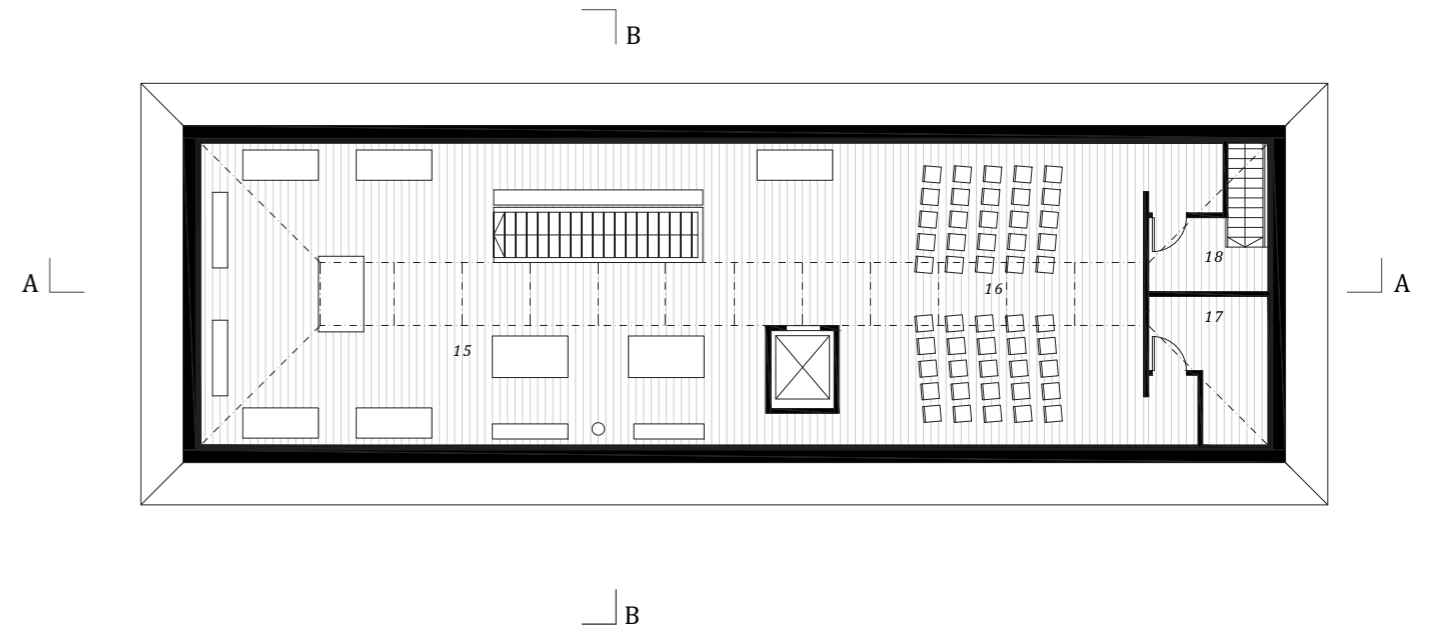

LEVEL TWO  
1:200



*The large space on the second floor houses the main permanent exhibition and a flexible space that could be used as a lecture hall where the amount of seats can be varied.*

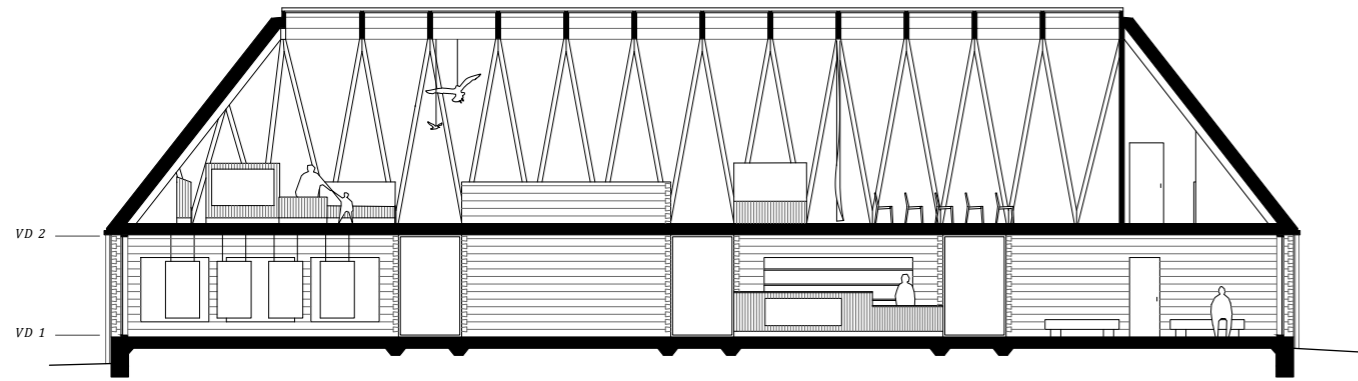

SECTION A-A  
1:200

*In contrary to the first floor, all light on the second floor is led in through the softed roof windows.*

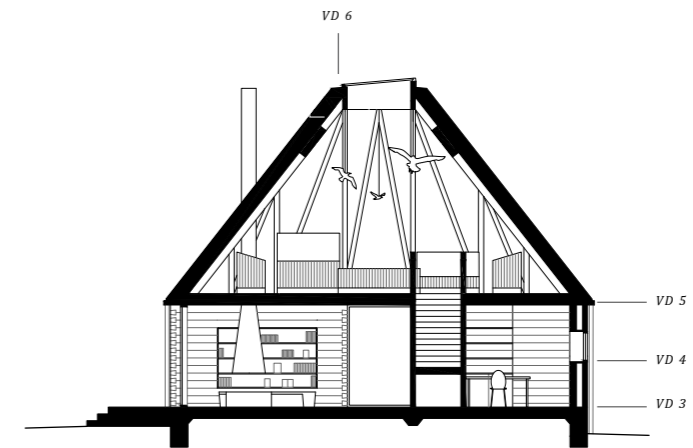

SECTION B-B  
1:200

*The stair becomes the only connection between the two floors to dramatize the experience moving between the different atmospheres.*

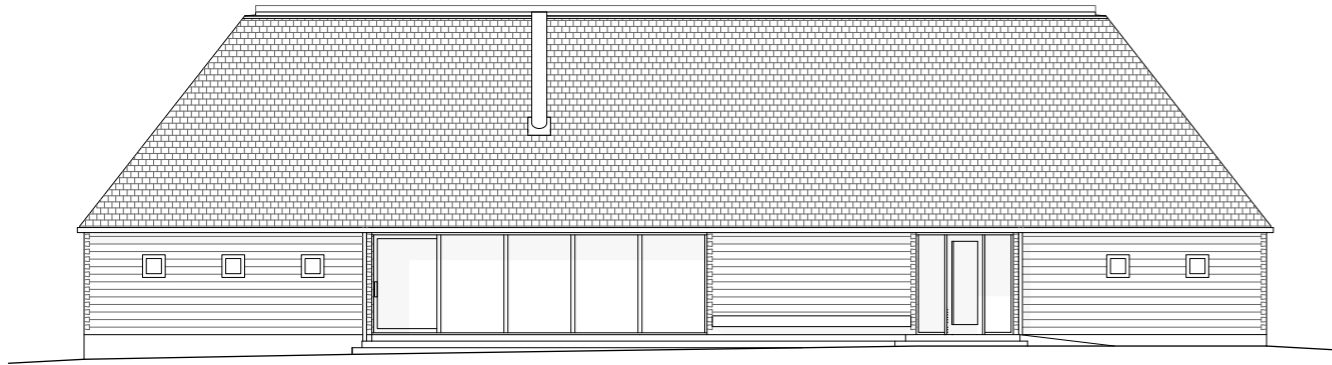

FACADE EAST  
1:200

*There are two types of openings in the facades,  
large between the boxes and small inside the boxes.  
On the broad terrace passing hikers can sit down for a while.*

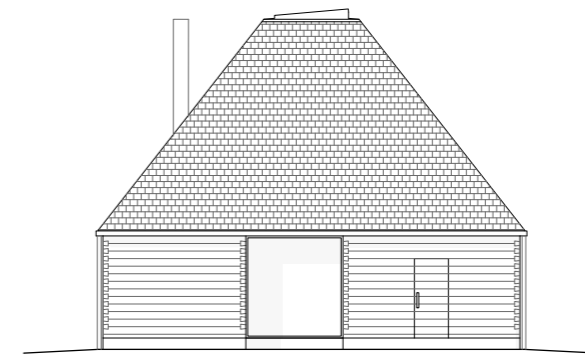

FACADE NORTH  
1:200

*Doors that are not main entrances are hidden into the log wall with added veneers  
of the same log and color.*

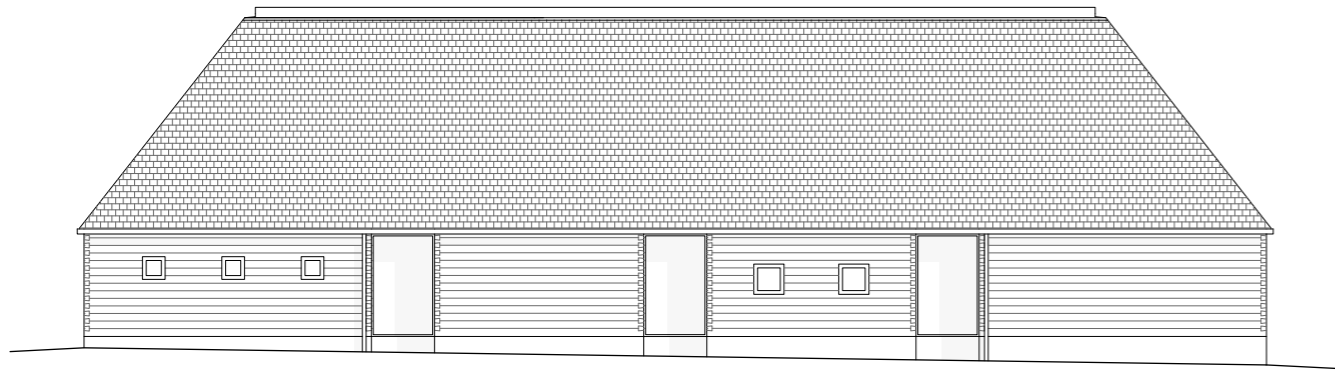

FACADE WEST  
1:200

*The small square shaped windows alter in size to adjust to different room functions.*

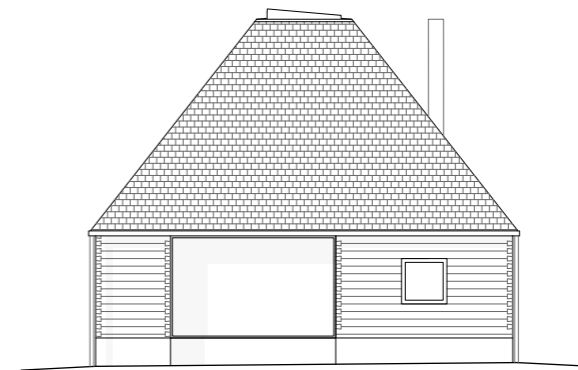

FACADE SOUTH  
1:200

*Similar to the the large windows, the plinth underneath them are pushed into the wall to strengthen the appearance of log boxes also from outside.*

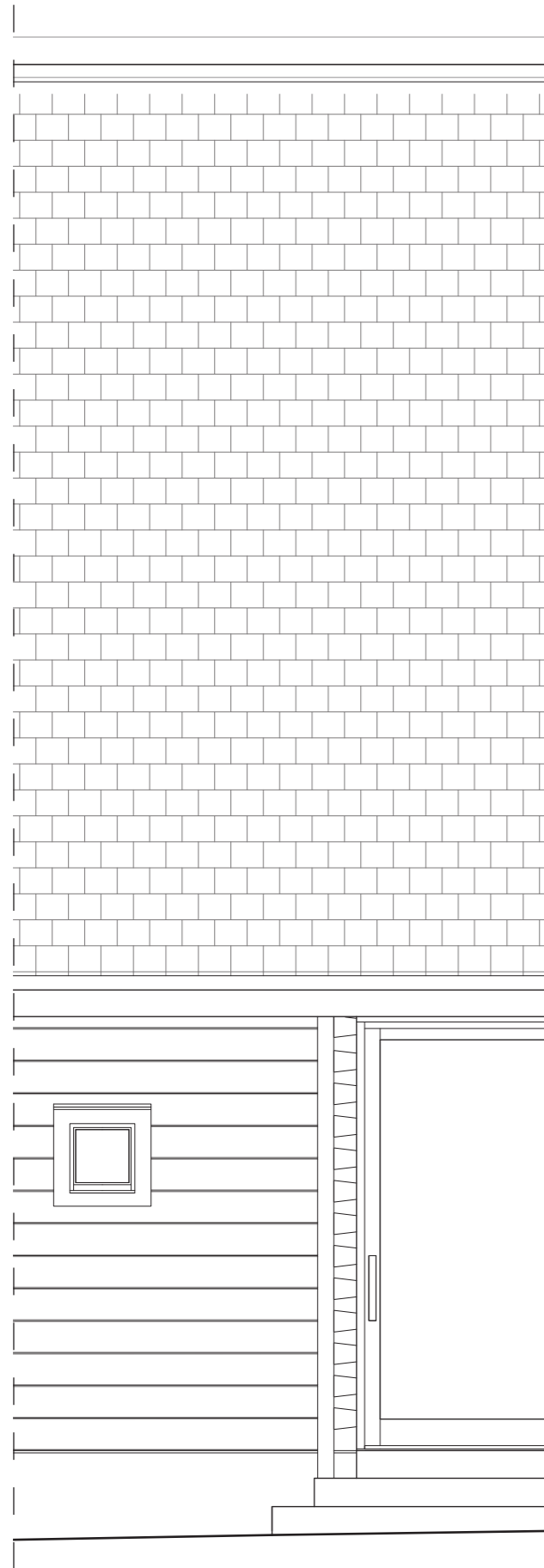

FACADE  
1:40

The visible roof truss is supported by horizontal glue laminated beams creating a collaborative effect making the roof truss stiff.

The forces of the roof construction is coming down on the inner log wall why this has a slightly larger dimension.

The concrete plinth is similarly to the log wall revealing presence in the construction.

1.	Roof Shingles 3 layers	(100-300)x600	
	Battens	25x45	
	Counter battens	25x45	
	Sealing layer	-	
	Construction plywood	15	
	Glulam beams/	200	
	Insulation		
	Construction Plywood	15	
	Roof truss glulam beam 200x130	200	
	/Wood fibre board, black, 10		
	/Pinewood ceiling 30x60 at cc75		
2.	Pinewood floor boarding 30x200	30	
	Wood fibre board	10	
	Glulam Beams 170x120 at cc1800	170	
	/Counter beams 170x45 at cc600		
	/Sound insulation 170		
	Battens 70x45 at cc600	70	
	/Installation layer 55		
	/Acoustic absorbant, black 15		
	Pinewood ceiling 30x60 at cc75	60	
3.	Timber log	130x200	
	Wood fibre insulation	160	
	Diffusion open vapour barrier		
	Timber log	180x200	
4.	Polished concrete	100	
	Ground insulation	300	
	Macadam	200	
	Fibre covering	-	

In the design of a naturum the building should express a closeness to the ecology, guiding the choice of wood shingle roof, which also is historically common on log timber buildings.

A dark brown pigmented oil staining brings a natural feeling to the wood and is also chosen as it can continue on the inside of the log walls creating a continuity in expression of the box shapes.

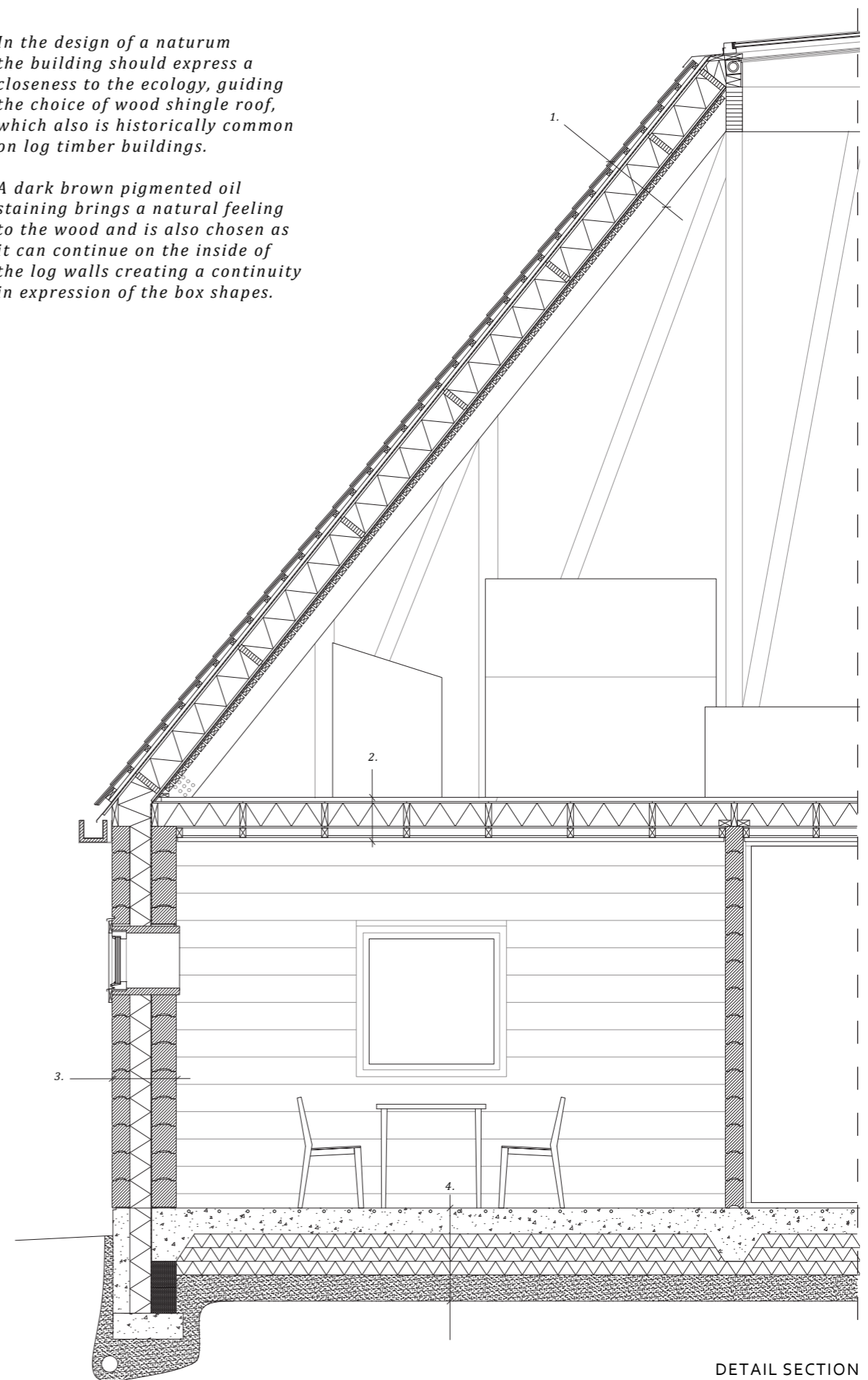

DETAIL SECTION  
1:40

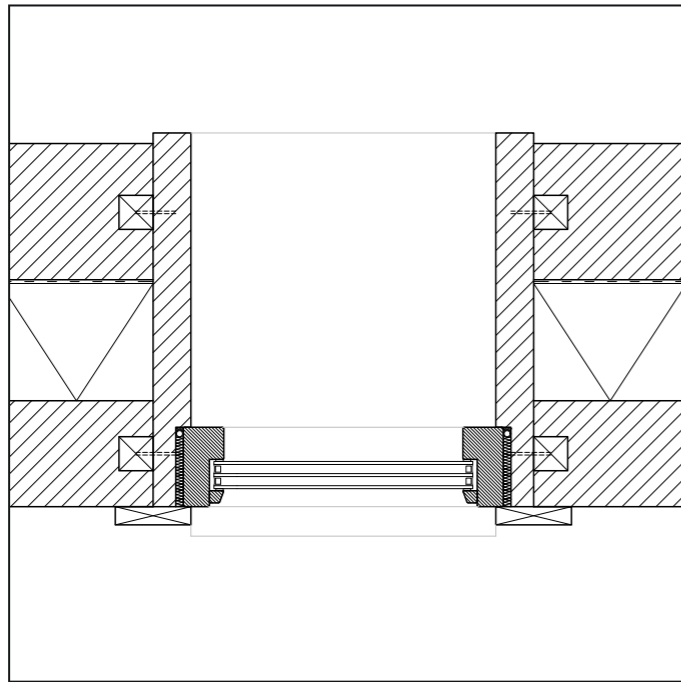

HD1 SMALL WINDOWS  
1:10

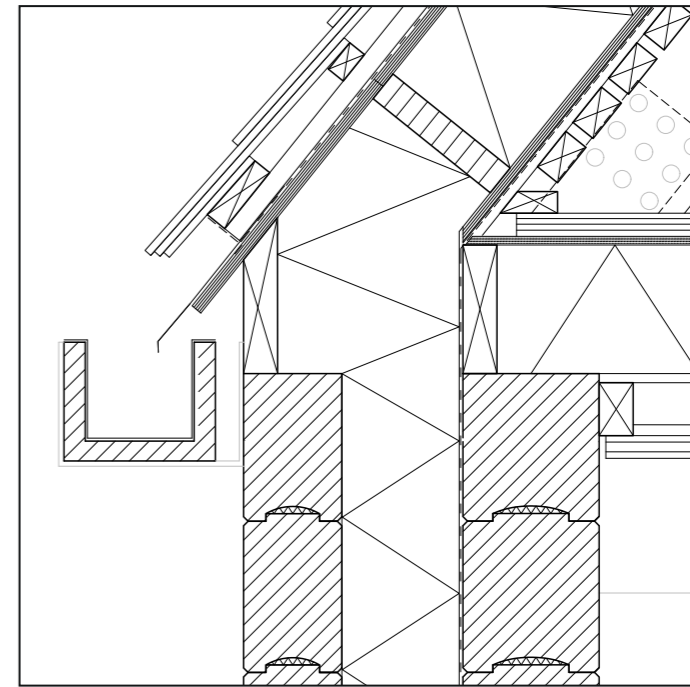

VD4 TIMBERWALL - ROOF  
1:10

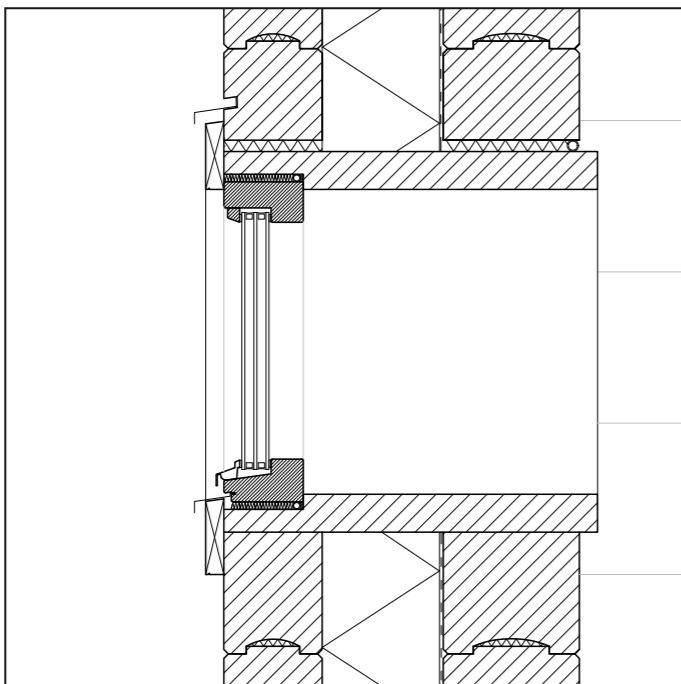

VD5 SMALL WINDOWS  
1:10

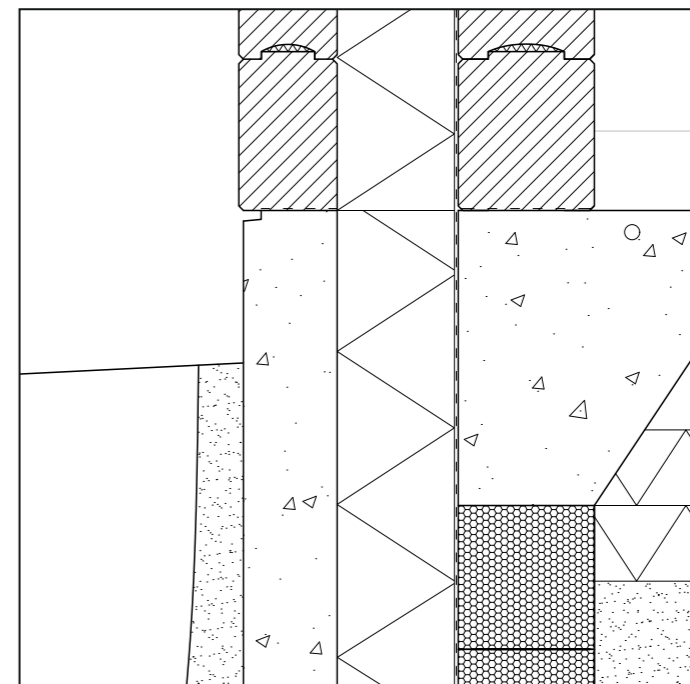

VD3 GROUND - TIMBERWALL  
1:10

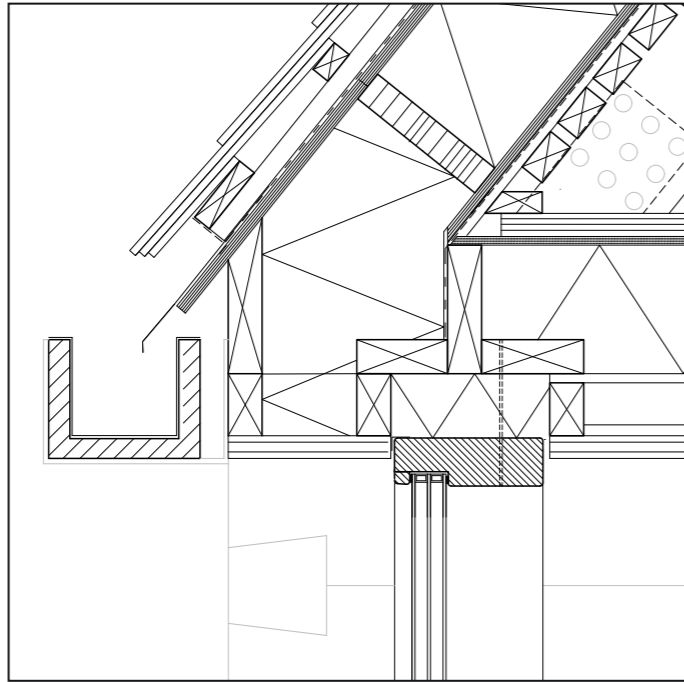

VD2 LARGE WINDOWS  
1:10

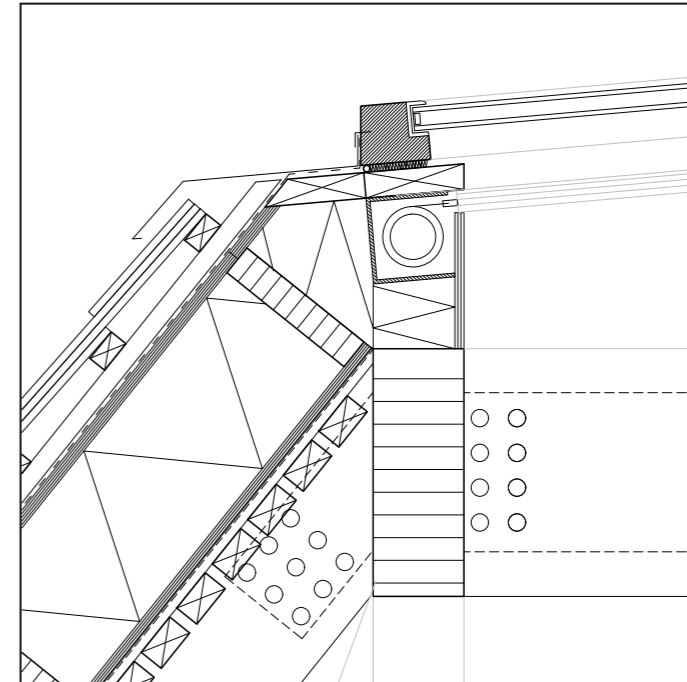

VD6 ROOF LIGHT  
1:10

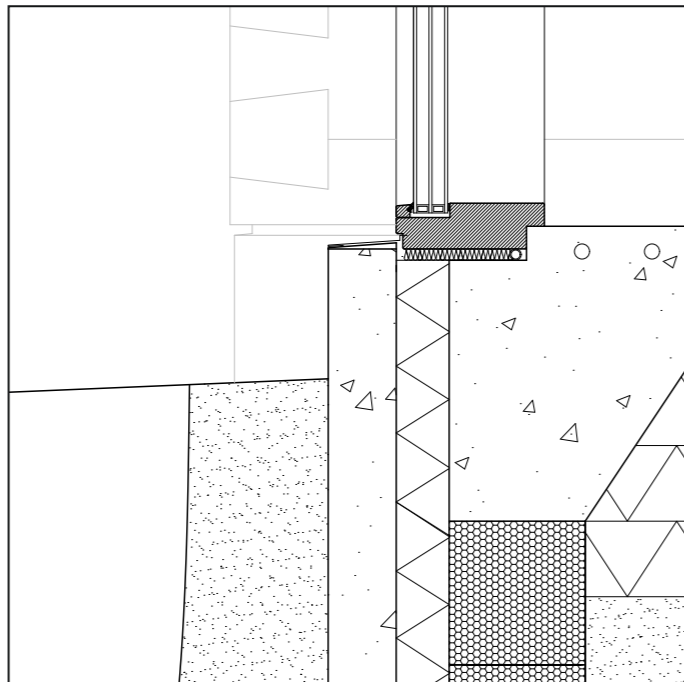

VD1 LARGE WINDOWS  
1:10

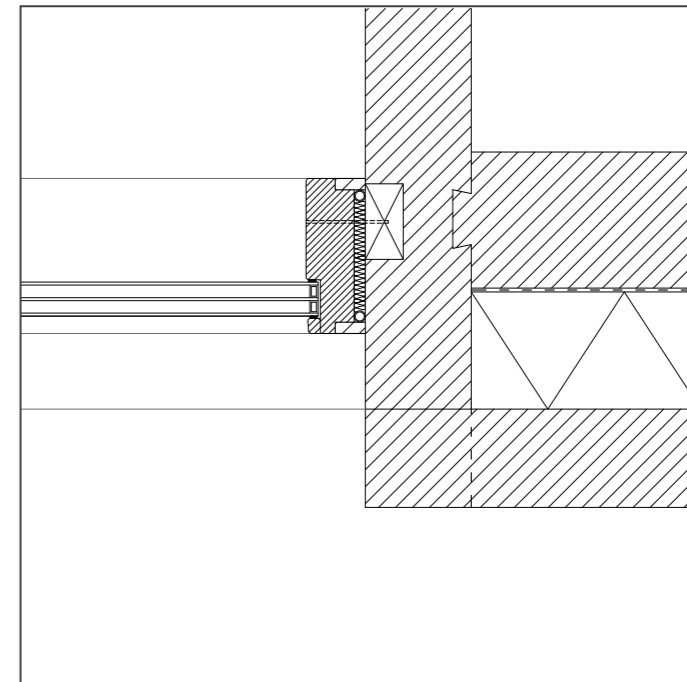

HD2 LARGE WINDOWS  
1:10





WARDROBE

*To create the feeling of continuity of the log boxes, the same color as in the facade is continuing into the building. A contrasting concrete floor and light acoustic wood ceiling are making the box shapes even clearer.*



RECEPTION & LOBBY

*Light is pouring down the stairs from the roof light, an invitation to explore the second floor. The knots, highlighted by the color staining repeats on all of the corners as the bearing detail of both interior and exterior expression.*



LIBRARY

*The library becomes the heart of the building, with a fireplace and large windows facing the mountaintop of "Middagsvålen".*



LECTURE HALL & EXHIBITION SPACE

*The same coloring principle is applied on the second floor where the load bearing elements are highlighted with a dark color staining.*

## SUPPORT BUILDING

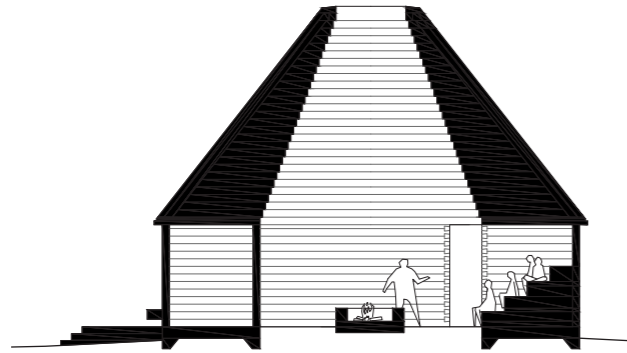

SECTION C-C  
1:200

The supportbuilding is a more direct reinterpretation of a sami hut. Here, the staff can gather larger groups of visitors around a fire, at the same time as it becomes a wind shelter for passing hikers. The fireplace is unisolated and has an open smoke hole at the top. In contrast to the main building, the log timbered boxes are organized in a way that directs the focus inwards, towards the center of the space and the opening above.

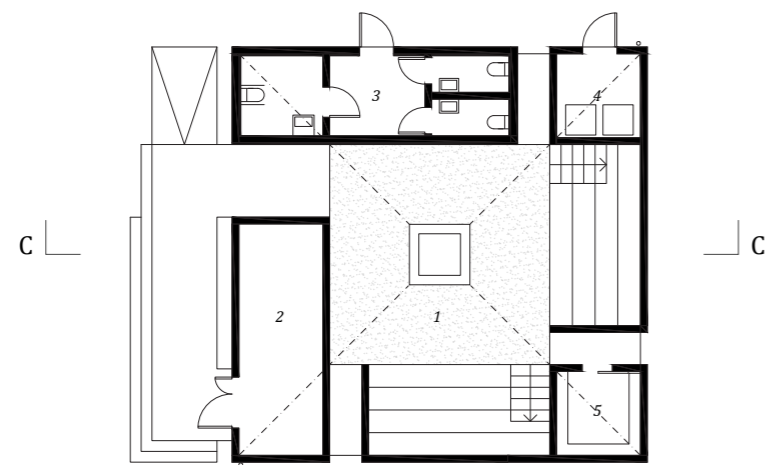

- 1. Gathering space
- 2. Storage
- 3. Restroom
- 4. Recycle room
- 5. Firewood storage

LEVEL ONE  
1:200

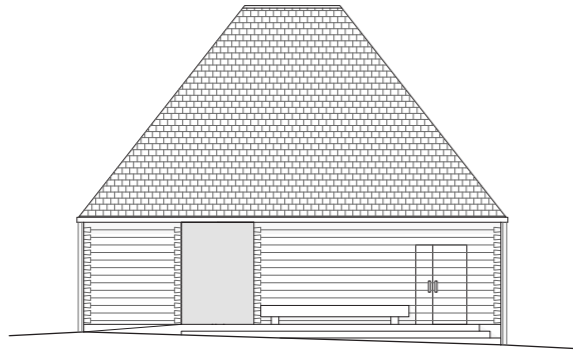

FACADE SOUTH  
1:200

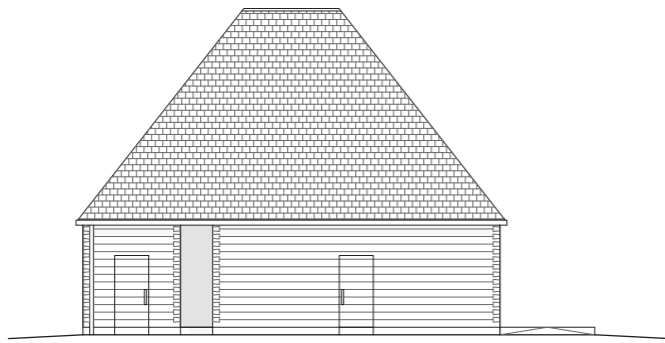

FACADE WEST  
1:200

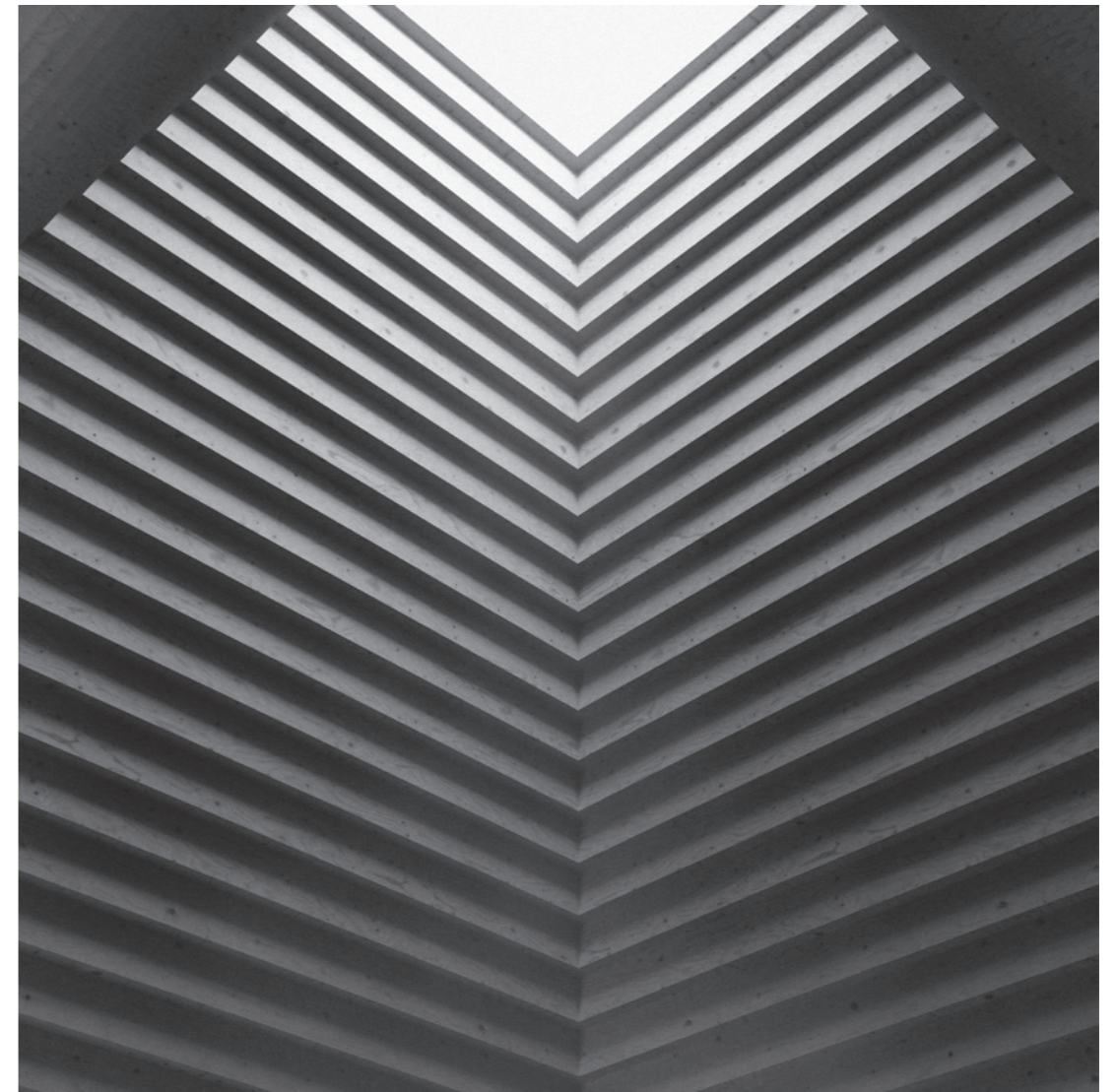

ROOF CEILING & SMOKE HOLE ABOVE THE FIREPLACE

# PHYSICAL MODELS



SITE MODEL  
1:1000

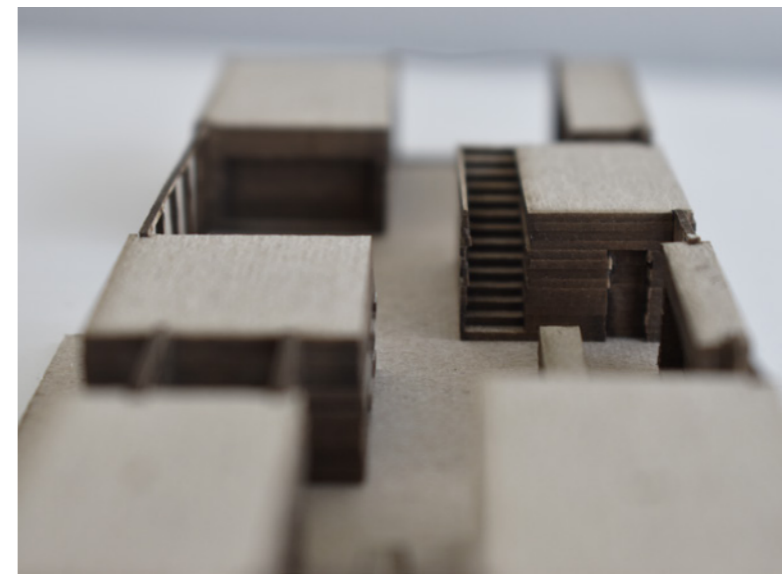
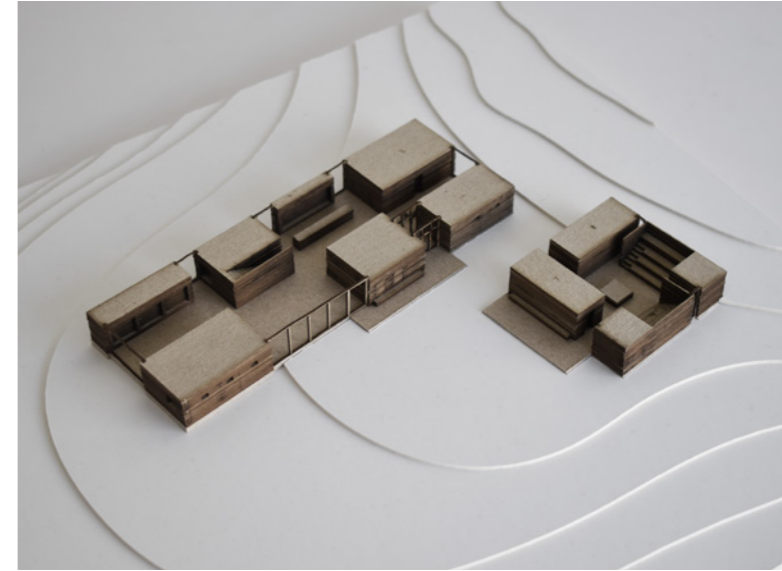

BUILDING PROCESS MODEL  
1:200

## *discussion*

Reflecting over my work I can see that choosing one of the two main questions to focus solely on would have been more than enough for the master thesis. On the other hand, maybe the combination of them also led to a design proposal that otherwise would have been less interesting and less specific for the context.

The particularity of the context gave rise to a challenge which doesn't feel very common when working with how new additions should relate to an existing built structure. In this case it was about trying to visualize a cultural heritage that is present but not so visible, while normally it is more about just relating to the visible context.

This resulted in a proposal that is bringing a new typology into the village setting. It is relating in scale, materiality and has simple shapes in similar configurations as the existing buildings in the village, but introduces a new type of roof. The building will support the narrative and history of the reserve better than the existing facility and be more visible in comparison not only through its location but also through its character.

The question is whether new buildings in this environment should deviate from the relatively cohesive nature of the existing character of the village, even if the intentions are good? Some could argue that the proposal is deviating from the character of the village a little too much. Still I think the arguments for doing so in this case can legitimize the addition.

Another reflecting question is if it's a good strategy to in the shape relate to building typologies that are so much more primitive than the building that is to be designed. One could argue for example that the large roof windows alluding to the roof smoke hole of the sami hut is adding a weak point into the building given the weather of the context that will put pressure on it over time. A different way to work with the context would have been to ask the question, how can you learn from the local building tradition to adapt to the local environment and weather? That question was a little overlooked in my process and if one would have asked that question the outcome would probably have been a bit different.

I've learned a lot about log construction and I can understand why other more modern construction methods are more common. It has been a struggle with the fact that the log construction is moving so much. There is a roughness in the properties of log construction that makes designing with precision a great challenge, why embracing the roughness in a design that is more forgiving probably is a good choice if working with log construction.

I've learned that the tradition of log construction is so much more than one thing, the development of the technique has resulted in many different options and ways of manufacturing that are more or less modern. For example it is nowadays common to construct with glue laminated logs that are being post tensioned with steel dowels, as compared to the traditional knitting of massive wood logs solely using wood as material. The question is when the beautiful simpleness of the technique lose its charm.

A conclusion is obviously that the technique works best in smaller less complex buildings like holiday homes and shelters rather than large public buildings with all its demands on technical installation, fire regulations etcetera. But on the other hand it is our public buildings that should have the best architectural qualities, why one could argue that they should be the obvious place investing in local craft and cultivation of local traditional building techniques.



## references

### Written sources

Beim, A., & Stylsvig Madsen, U. (2014) *Towards an Ecology of Tectonics*, Edition Axel Menges

Håkansson, Sven-Gunnar. (2017) *Från stock till stuga*, Massolit förlag

Lauri, T. Isitt, M. Caldenby, C. (2013). *Sveriges Naturum*, Arkitektur Förlag

### Web sources

Länsstyrelsen jämtlands län. (2019). *Vålådalen*.

Retrieved 200110 from <https://www.lansstyrelsen.se/jamtland/besoksmal/naturreservat/valadalen.html>

Nationalencyklopedin. (2020). *Vålådalen*.

Retrieved 200110 from <https://www.ne.se/uppslagsverk/encyklopedi/lang/vaaldalen>

Naturvårdsverket. (2019). *Naturum*.

Retrieved 200110 from [www.naturvardsverket.se](http://www.naturvardsverket.se)

Naturvårdsverket. (2015) *Riktlinjer för naturum (6696)*. Naturvårdsverket. Retrieved from <https://www.naturvardsverket.se/Om-Naturvardsverket/Publikationer>

Sveriges arkitekter. (2009) *Naturum Laponia*

Retrieved 200110 from <https://www.arkitekt.se/tavling/naturum-laponia/>

Vålådalens Fjällstation. (2020) *Vår historia*

Retrieved 200110 from <https://www.valadalen.se/sv/var-historia>

### Image sources

Images and drawings without source are produced by the author of the thesis





**CHALMERS**  
UNIVERSITY OF TECHNOLOGY

Mikael Junehag  
Master Thesis Spring 2020