

Modeling and Simulation of Vehicular Power Systems

Master's thesis in the International master's 'Program 'Electric Power Engineering''

Siavash Zoroofi

Department of Energy and Environment
Division of Electric Power Engineering
CHALMERS UNIVERSITY OF TECHNOLOGY
Göteborg, Sweden, 2008

MASTER'S THESIS 2008

Modeling and Simulation of Vehicular Power Systems

Master's Thesis in Electric Power Engineering

Siavash Zoroofi

Department of Energy and Environment

Division of Electric Power Engineering

Chalmers University of Technology

Göteborg, Sweden, 2008

Modeling and Simulation of Vehicular Power Systems
Master's Thesis in Electric Power Engineering

Siavash Zoroofi

© SIAVASH ZOROOFI

Master's Thesis 2008

ISSN 1652-8557

Department of Energy and Environment

Division of Electric Power Engineering

Chalmers University of Technology

SE-412 96 Göteborg

Sweden

Telephone: +46 (0) 31-772 1000

To my parents, brother and my love Sara

Acknowledgment

Over the course of this thesis, many wonderful colleagues and friends have contributed immeasurably.

I am especially grateful to my supervisor Dr. Shahin Fillizadeh for his great assistance of proofreading, financial and many other things considering the project.

I also would like to thank my examiner Prof.Torbjorn Thiringer at Chalmers University of Technology for numerous fruitful discussions and invaluable comments.

The financial support from the University of Manitoba is gratefully acknowledged.

Furthermore, I thank all the personnel at Chalmers University of Technology for their effort to provide an interesting program and a nice working environment.

Finally, my appreciation goes to my parents who supported me all through my education time.

Siavash Zoroofi

March 2008, Goteborg, Sweden

Abstract

Regarding limitation of fossil fuels and the high consumption rate of this energy for transportation, inclination of vehicle industry toward other sources of energy is inevitable. Electric vehicles and hybrid vehicles could be a good solution. Thanks to the state of art electric motors, power electronics, embedded power train controller, energy storage systems like batteries and ultra capacitors, the performance of the vehicle could become more and more energy efficient. Since the integrating of all these components in a drive train configuration could be a challenge for the manufacturer, computer simulation and modeling before prototyping could be really beneficial in terms of cost, safety and design performance. In this thesis some of the principles of modeling and simulation are discussed. The main components in hybrid vehicles are modeled and different methods of modeling are discussed. As battery plays a significant role in electric and hybrid vehicles, modeling of it is of importance. In this thesis some of the methods to model Lead-acid and Lithium-ion battery are introduced. Some tests in order to find the internal parameters of the battery are explained and based on the data from the tests a Lithium-ion battery is modeled in Simulink/Matlab. The dynamics of the vehicle in terms of longitudinal and lateral forces are discussed and a model representing the phenomenon of wheel slip is developed in Simulink. Modeling of engine and electric motors is explained. Having models in Matlab/Simulink, a series hybrid drive train including batteries, motor, generator, vehicle dynamics and control system is simulated. Given the data from the test data from a series hybrid bus manufactured by the New Flyer Company, the performance of the vehicle in terms of fuel economy, acceleration and maximum cruise speed is analyzed. The behavior of different components is also discussed. Finally, comparing the simulation results with test data, it is shown that modeling and simulation could be really helpful in design process. The battery model was verified with measurements and is proved to have a good accuracy.

Table of Contents

Acknowledgment	iii
Siavash Zoroofi	iii
March 2008, Goteborg, Sweden	iii
Abstract	iv
Table of Contents	v
List of Tables	ix
List of Symbols	x
1 Introduction	1
1.1 Objective of the thesis.....	1
1.2 Thesis outline	1
2 Background	3
2.1 Hybrid Electric Vehicles.....	3
2.2 Hybrid Vehicles as an Alternative Solution.....	4
2.3 Simulation of Hybrid Vehicles	5
2.4 Hybrid Vehicles Drive Trains.....	6
2.4.1 Series Hybrid Vehicles	7
2.4.2 Parallel Hybrid Vehicles.....	9
3 Simulation and Modeling Principles	11
3.1 Physics Based Modeling.....	12
3.2 Numerical Integration Methods.....	13
4 Vehicle Dynamics Modeling	15
4.1 Wheel Dynamics and Wheel slip.....	17
4.1.1 Normal load on each wheel.....	20
4.1.2 Friction coefficient and slip modeling	20
4.2 Transmission	22
5 Battery Modeling	24
5.1 Electrochemical battery models.....	24
5.1.1 Peukert equation.....	24
5.1.2 Battery capacity and discharge current.....	25
5.2 Shepherd Model Equation.....	26
5.3 <i>Unnewehr</i> Universal Model.....	26
5.4 EQUIVALENT CIRCUIT BATTERY MODELS	27
5.4.1 Thevenin battery model	27
5.4.2 Linear dynamic model	29
5.4.3 Nonlinear dynamic model.....	29
5.5 Thermal modeling of the battery.....	31
5.6 Parameters measurement	32
5.6.1 Open circuit voltage.....	32
5.6.2 Charging and Discharging Resistances.....	33
5.6.3 Capacitor.....	35
5.6.4 Battery capacity	36
6 Engine, electric machine and control system modeling	37

6.1	Electric motors	37
6.2	Internal combustion engine	38
6.3	Control system	40
7	Modeling in Simulink/Matlab	41
7.1	Battery	41
7.1.1	Thermal model	42
7.2	Vehicle dynamics	42
7.2.1	Tyre	44
7.3	Engine	45
7.4	Electric Motor	45
7.5	Driving Cycles	45
7.6	Automatic Driver	46
7.7	Control and energy Management	48
8	Simulation Results	49
8.1	Battery simulation results	49
8.2	Series hybrid bus simulation	50
8.3	Acceleration performance	51
8.4	CBD drive cycle test	53
9	Conclusion	59
9.1	Future Work	59
	References	61

List of Figures

Figure 2-1: Oil consumption in the world.....	3
Figure 2-2: Oil consumption per region.....	3
Figure 2-3: Carbon dioxide emission distribution from 1980 to 1999	4
Figure 2-4: Generic traction system structure.....	7
Figure 2-5: Functional block diagram of a series hybrid vehicle	8
Figure 2-6: Configuration of a series hybrid vehicle	8
Figure 2-7: Functional block diagram of a parallel hybrid vehicle	9
Figure 2-8: Configuration of a parallel hybrid vehicle	10
Figure 3-1: RCF modeling.....	12
Figure 3-2: EMTS solution flow-chart	14
Figure 4-1 Vehicle longitudinal forces	15
Figure 4-2: The deflection of tyre and rolling resistance.....	16
Figure 4-3 Tractive force change with slip of tyre.....	18
Figure 4-4 Torques and forces on the wheel.....	19
Figure 4-5 Friction coefficient change with slip for different road types.....	21
Figure 4-6 Tractive effort of internal combustion engine and a multi-gear transmission vehicle vs. vehicle speed.....	22
Figure 5-1 Peukert curve and capacity change of battery versus discharge current.....	25
Figure 5-2: Battery Thevenin model.....	28
Figure 5-3: Modified Thevenin model.....	28
Figure 5-4: Battery linear model.....	29
Figure 5-5: Battery nonlinear model.....	30
Figure 5-6 Battery model updating chart.....	31
Figure 5-7 Test procedure for measurement of open circuit voltage.....	32
Figure 5-8 Battery open circuit voltage versus state of charge.....	33
Figure 5-9 Circuit for determining of open circuit voltage.....	34
Figure 5-10 Discharge resistance versus state of charge	34
Figure 5-11 Charging resistance versus state of charge.....	35
Figure 5-12 Circuit to determine battery capacitance.....	36
Figure 5-13 Transient behavior of battery terminal voltage during load change	36
Figure 6-1 Efficiency map of a typical PMSM.....	37
Figure 6-2 Dynamic models for PMSM (left) and DC motor (right)	38
Figure 6-3 Engine efficiency map.....	39
Figure 6-4 Engine torque & speed characteristic.....	39
Figure 7-1 Block diagram of battery model.....	42
Figure 7-2 Battery thermal model block diagram.....	42
Figure 7-3 Vehicle dynamics block in Matlab/Simulink.....	43
Figure 7-4 Vehicle dynamic block components	44
Figure 7-5 Tyre block in Matlab/Simulink	44
Figure 7-6 City Bus Drive cycle (CBD)	46
Figure 7-7 Automatic driver model block in Matlab/Simulink	47
Figure 8-1 Battery charging test	49
Figure 8-2 Battery discharging test.....	50
Figure 8-3 Acceleration test of bus.....	51
Figure 8-4 Wheel speed and translated actual vehicle speed.....	52

Figure 8-5 Wheel speed and translated actual vehicle speed.....	53
Figure 8-6 Bus speed	54
Figure 8-7 Engine and generator power and speed curve.....	55
Figure 8-8 Electric motor torque, speed and efficiency.....	56
Figure 8-9 Battery state of charge change	57
Figure 8-10 Fuel power, fuel consumption and average engine efficiency.....	58

List of Tables

Table 3-1 List of some soft wares used in hybrid vehicle simulations	11
Table 4-1 Drag coefficient for different body shapes	17
Table 4-2 Parameters of the wheel dynamics equation	19
Table 4-3 Pacejka coefficients for different road types	21
Table 6-1 Diesel engine specifications	38
Table 8-1 Simulation data for series hybrid bus	50
Table 8-2 Simulation and test result for fuel economy	58

List of Symbols

μ	Friction coefficient
f	Front
r	Rear
T_e	Driving torque from the engine or motor
T_b	Braking torque
F_t	Total tractive force
F_{tr}	Total resistive force
J_w	Wheel inertia
W_w	Wheel speed
F_w	Wheel viscous friction force
W_f	Normal load on the front axle
W_r	Normal load on the rear axle
L_a	Distance of front axle from the center of gravity
L_b	Distance of rear axle from the center of gravity
L	Distance between the front and rear axles
h_g	Center of the aerodynamic force height from the ground
h_w	Center of the gravity force height from the ground
V	Vehicle speed
M_v	Total weight of the vehicle
T_r	Rolling resistance torque on the wheel
P	Normal load on the wheel
a	Distance from the center of normal load on each wheel
$F_{rolling}$	Rolling resistance
r_d	Wheel radius
C_r	Rolling resistance coefficient
$F_{Aerodynamic}$	Aerodynamic force
ρ	Air density
A_f	Frontal area of the vehicle
C_d	Aerodynamic resistance coefficient
V_w	Wind speed
F_{grade}	Grading resistance
g	Earth gravity
α	Grade angle
λ	Slip
λ_a	Slip during acceleration
λ_b	Slip during braking
a	Acceleration subscript
b	Braking subscript
F_r	Total rolling resistance
F_{tmax}	Maximum tractive force
T_{wheel}	Wheel torque
N_g	Gear ratio
N_d	Final drive ratio
$\eta_{transmission}$	Transmission efficiency

T_t	Engine torque
W_t	Engine speed
C	Battery capacity
T_i	Battery discharging time
I	Current
n	Battery constant
SOC	State of charge
t	Time
Δt	Time step
E_t	Battery terminal voltage
E_o	Battery open circuit voltage
R_i	Battery internal resistance
K_i	Battery polarization resistance
q	Accumulated battery charge over full charge
E_{oc}	Battery open circuit voltage
R_o	Total internal resistance of a fully charged battery
K_R	Experimental constant
p	Out-put power
p_{max}	Maximum out-put power
R_c	Charging internal resistance
R_d	Discharging internal resistance
C_l	Battery capacitance
m	Battery mass
C_p	Batter heat capacity
T	Temperature
R_{int}	Battery total internal resistance
$i(t)$	Instantaneous current
h_c	Heat coefficient
A	Battery cooling area
T_a	Ambient temperature
R_{load}	Load resistance
V_{oc}	Open circuit voltage
V_b	Battery terminal voltage
R_l	Load resistance one
$y(t)$	Out-put for RCF model in each time
h	Simulation time step
G	Jacobian matrix
b_1	Constant in RCF
b_2	Constant RCF
τ	Voltage time constant

1 Introduction

Nowadays electric and hybrid vehicles are being more and more placed in the center of attraction because of the importance of shortage in fossil fuels. As simulation and modeling of different hybrid and electric vehicles plays an important role before the design and manufacturing process, having a simulation environment which includes different models for components used in drive train could be really beneficial [8]. To have a good simulation environment, it is needed to make a library of models of components exist in the drive train of vehicles. There are so many simulation programs being used for study and analysis of different drive trains [8], [6]. Different components in the drive train of hybrid vehicles are modeled with different methods [7], [8], [1], [4]. The importance and benefit of having a simulation environment is discussed in [5], [22]. In [15] some methods to model internal combustion engines is discussed. In [17], [18], [23], [24], different methods to simulate batteries is given and discussed. The energy management and control strategies used in hybrid drive trains is presented in [14]. In [1], [2], [3], [7], [9] some methods for modeling of electric machines are given. As the whole drive train of hybrid vehicles is a combination of electric and mechanical components, the dynamic modeling of the vehicle and mechanical parts is in the aspect of interest. In [4], [8], [10], [11], [12] and [13], the dynamics of the vehicles and how to model it is discussed.

1.1 Objective of the thesis

The purpose of this thesis is to provide some tools and methods for modeling and simulation of components used in drive trains of hybrid vehicles. A goal is to introduce principles of simulation and the methods used for simulation of vehicular power systems. It is desired to create a simulation model for different components used in vehicle drive train. Different methods used to model vehicle dynamics, batteries and electric motors, engine is given. Altogether making a simulation environment to show the importance of modeling and simulation of vehicular power systems is one of the main objectives of this thesis.

1.2 Thesis outline

This thesis is arranged in nine chapters. The first chapter, which constitutes the introduction, provides the aim and scope of the thesis and what is done to accomplish the aims.

Chapter 2 includes some theoretical background of hybrid vehicles and clarifies the importance of simulation and modeling of vehicular power systems.

Chapter 3 focuses on the basic and principles of simulation and modeling. Some simulation tools which are used for vehicles simulations and comparison of them is given.

Chapter 4 discusses the dynamics of the vehicle and a method to model the dynamics behavior of vehicles is given.

Chapter 5 presents the principles of modeling of batteries as an important part in electric and hybrid vehicles drive train. Some models are introduced and compared with each other. At the end of a nonlinear model which can be used for Lithium-ion, Lead-acid and Nickel-metal-hydride battery is given.

Chapter 6 includes some methods for electric machines and engine modeling. At the end, the energy management and control system is discussed.

Chapter 7 focuses on the modeling blocks of different components in the drive train of hybrid vehicles and shows how to create the models in Matlab/Simulink.

In Chapter 8 a typical drive train of a series hybrid bus is made and the performance of the simulation model is analyzed.

Finally in chapter 9 the overall conclusions of thesis work are given and it outlines some future work.

2 Background

2.1 Hybrid Electric Vehicles

The increase of depletion of fossil fuels for multiple purposes like generation of other forms of energy (electricity, heating and transportation) is growing. This growth is much faster than the time it takes to aggregate the energy stored in new oil and coal, so new solutions for finding other energy sources is needed.

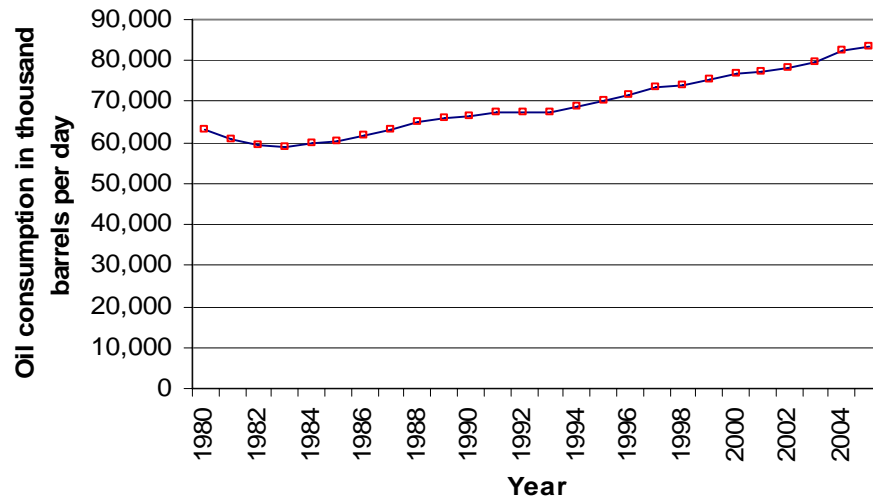

Figure 2-1: Oil consumption in the world

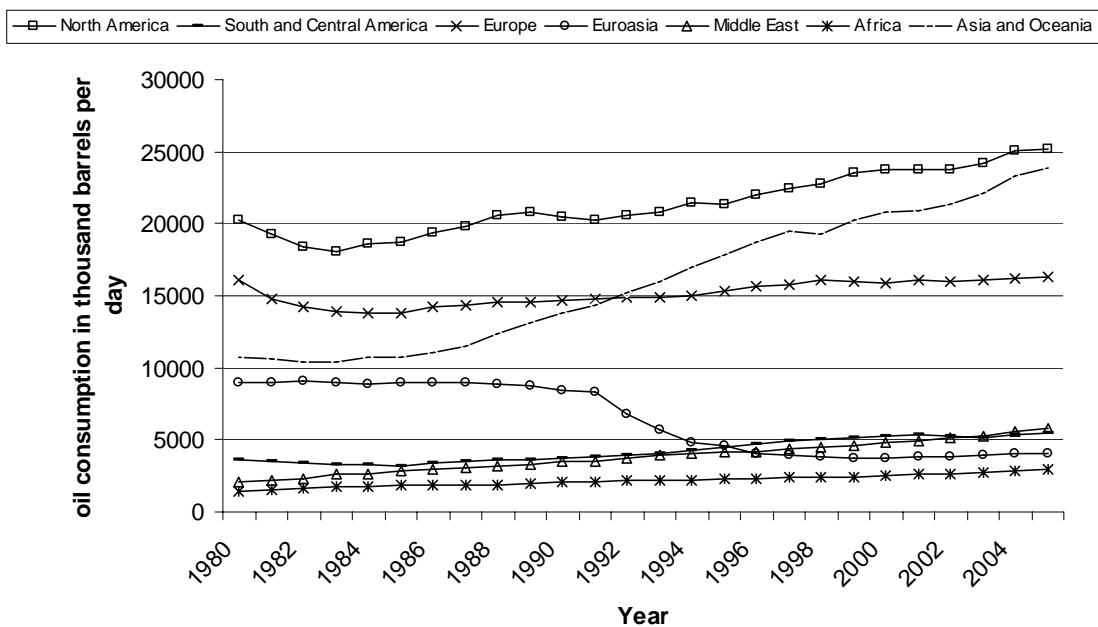

Figure 2-2: Oil consumption per region

The Other environmental effects of the usage of fossil sources are really going to become a serious problem in the near future. Air pollution and global warming are two of the most important ones [11]. Most of the conventional vehicles use internal combustion engines (ICE) in which the fuel reacts with oxygen and produces heat, some gases (CO₂, CO, HC and NO_x) and mechanical power. The combustion of hydrocarbon fuel in combustion engines is never ideal so some other gases are produced after the reaction besides carbon dioxide and water. The combustion products contain a certain amount of nitrogen oxides (NO_x), carbon monoxides (CO), and unburned hydrocarbons (HC), all of which are toxic to human health. The carbon dioxide and other green house gases like methane play a significant role in global warming. These gases trap the Sun's infrared radiation reflected by the ground, thus retaining the energy in the atmosphere and increasing the temperature [11]. An increased earth temperature results in major ecological damages to its ecosystems and in many natural disasters that affect human populations.

The part of transportation effect on global warming and air pollution is indicated in figure 2-3.

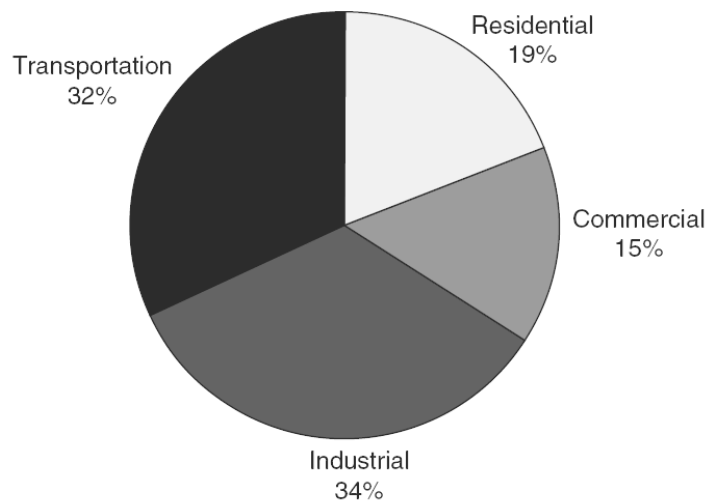

Figure 2-3: Carbon dioxide emission distribution from 1980 to 1999

2.2 Hybrid Vehicles as an Alternative Solution

Based on the reasons mentioned above and as the transportation has a major role in daily life, finding of sustainable fuel energy with the lowest emission is highly desirable which for transportation, it means:

- a) There is a need to reduce emissions related to transportation.
- b) There is a need to base transportation operating on renewable fuels.

Hybrid vehicles and fuel cells can be one of the solutions. The advancement in the technology of power electronics, electric machines and the usage of different control methods the vehicle is able to:

- Recapturing the regenerative braking energy
- Having more efficient operating points for the combustion engine
- Eliminating of engine idling time
- Using of different control and energy management algorithms

The above abilities have caused the following benefits of hybrid vehicles:

- Decrease fuel consumption
- Decrease emissions
- Increase the life cycle of mechanical parts
- Increase total efficiency

The hybrid vehicle (HV) can be a cost effective way to improve fuel economy, reduce emissions, and still maintain customer demands of performance, comfort, and cost.

2.3 Simulation of Hybrid Vehicles

In a comparison between conventional and hybrid electric vehicles drive trains, it is seen that the role of electric components like electric machines, power electronic converters and embedded power train controllers is really significant. There are so many state of the art energy storage components like batteries, super capacitors. Vehicles also use modern internal combustion engine and mechanical components.

In each design process of hybrid and electric vehicles, all the components in the drive train should be chosen, rated and controlled in such a way that the whole design is optimized for getting the best performance in terms of cost and fuel consumption and reliability. To achieve this goal having a simulation environment with the model of each component representing the real behavior of it could help to get to better design and save money.

Modeling and simulation are indispensable for concept evaluation, prototyping, and analysis of hybrid vehicles. This is particularly true when novel hybrid power train configurations and controllers are developed. [8]

Computer simulation has long been an essential way, and of major significance, in the design process of modern industrial systems. Computer simulation can be used to reduce the expense and length of a design cycle of hybrid vehicles by testing configurations and energy management systems before prototype construction begins [8]. It also provides a reliable alternative in situations where the studies or tests to be performed are dangerous and expensive (crash test of a vehicle), or strategically unfavorable (short-circuit test on a power transmission line) [6]. Further more the complexity of sophisticated new power trains dependence on different control strategy is also a concern in automotive research.

So a modeling tool being able to design not only drive train components but also embedded control software is needed.

2.4 Hybrid Vehicles Drive Trains

As the name expresses, hybrid vehicles get benefit of minimum two energy sources. The demanded power for traction and other auxiliary loads in the vehicle is shared between two sources of energy with a specific power sharing management. The main parts of each hybrid vehicle could be classified as:

- Primary energy storage system
- Secondary energy storage system
- Primary energy converter
- Secondary energy converter
- Control system
- Transmission

In figure 2.4 examples of energy storage systems and different energy conversion units are shown.

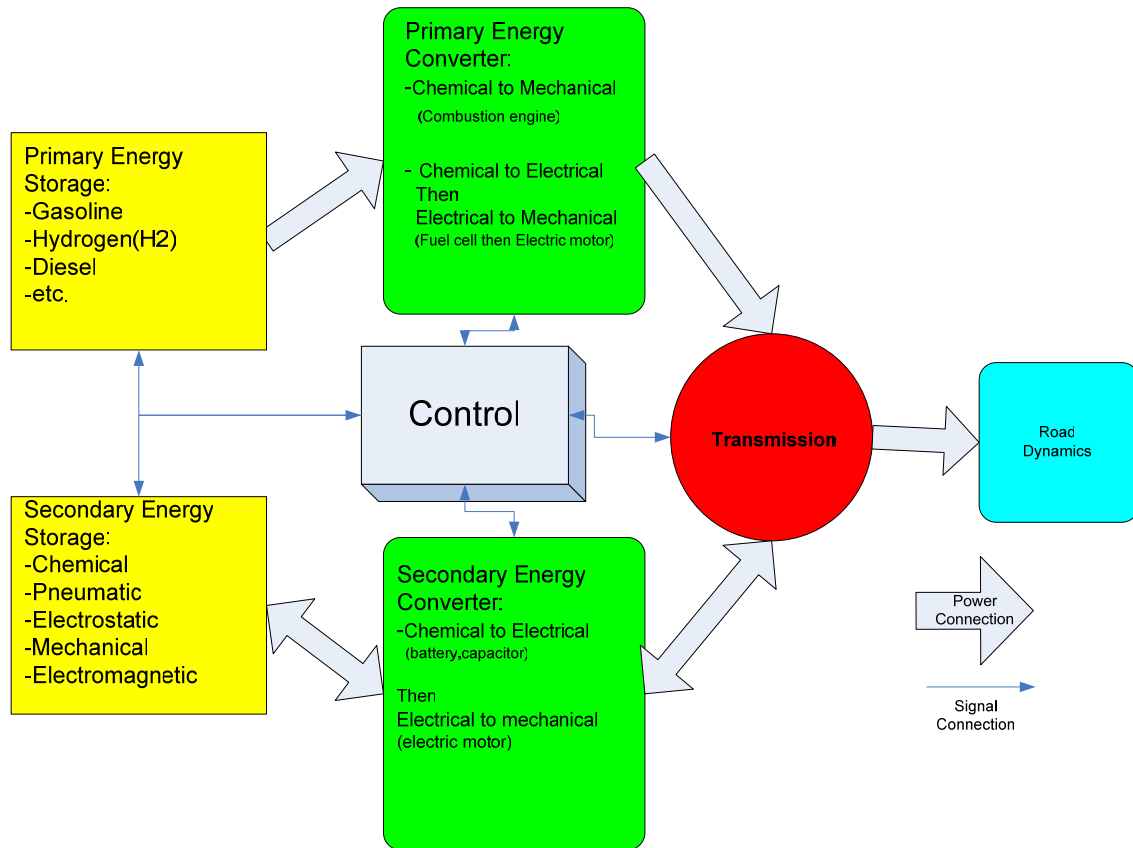

Figure 2-4: Generic traction system structure

There are different topologies of hybrid vehicles but series and parallel topologies are the most commonly used ones [9]. Hybrid electric systems can be broadly classified as series or parallel hybrid systems [4], [5]. In series hybrid systems, all the torque required to propel the vehicle is provided by an electric motor. On the other hand, in parallel hybrid systems, the torque obtained from the heat engine is mechanically coupled to the torque produced by an electric motor. In an electric vehicle, the electric motor behaves exactly in the same manner as in a series hybrid. Therefore, the torque and power requirements of the electric motor are roughly equal for an electric vehicle and a series hybrid, while they are lower for a parallel hybrid [8].

Each topology has its own drive train and components. It also has its own advantages and disadvantages and uses different control strategies. In the following, the principle and main components of each topology will be explained.

2.4.1 Series Hybrid Vehicles

In this topology the primary energy converter is the internal combustion engine (ICE) which has been connected to an electric motor working as a generator. The out-put of the generator through power electronic converters is connected to the secondary energy storage which is a battery. The battery via power electronic converters is connected to an

electric motor to provide the tractive force on the wheels of the vehicle through the transmission system [11]. The series configuration is shown in figure 2-5 and 2-6.

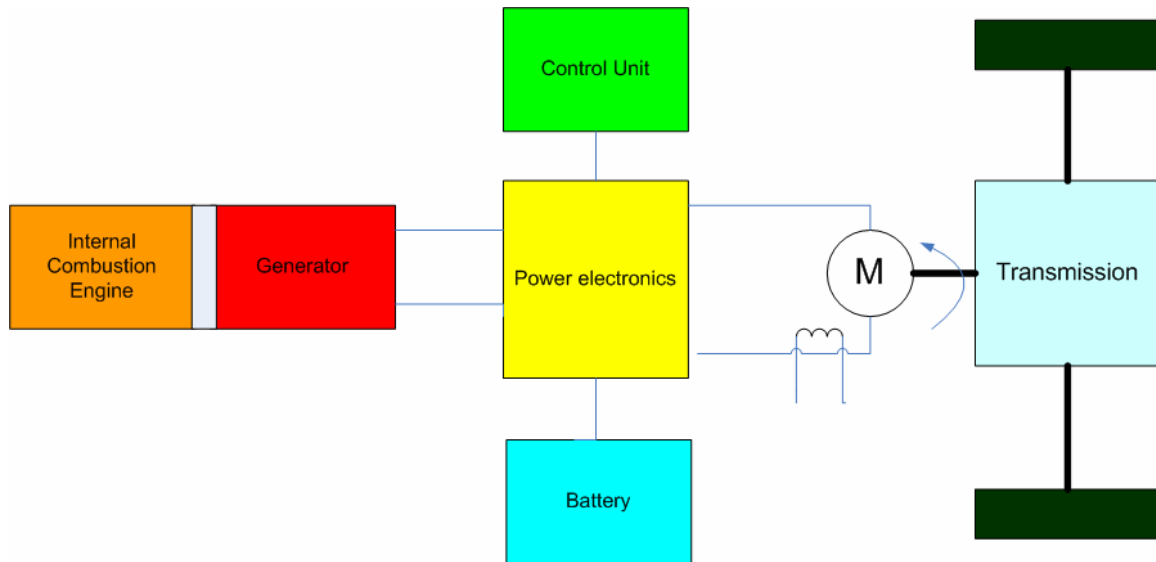

Figure 2-5: Functional block diagram of a series hybrid vehicle

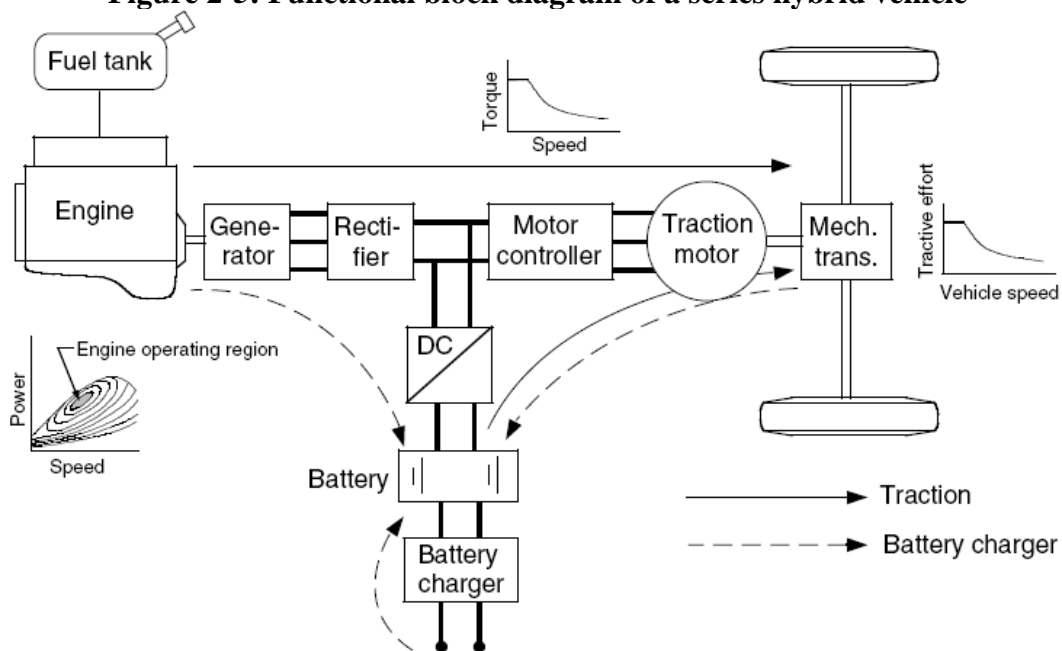

Figure 2-6: Configuration of a series hybrid vehicle

As the internal combustion engine is not connected directly to the transmission system so it can be run at the best efficiency operation points which consequently results in less fuel consumption.

In series hybrid vehicles the traction power must be transferred to the wheels through the traction motor. The cost and weight of the traction motor in order to provide the needed

power during acceleration and regenerative energy is a constraint in this type of hybrid vehicle [11].

2.4.2 Parallel Hybrid Vehicles

In this topology, figure 2-7 and 2-8, the main energy source and the secondary energy source are connected in parallel to the transmission system. It means that both the internal combustion engine and the traction motor apply a torque to the shaft of the transmission system. In this configuration the combustion engine is responsible to provide the traction power and the power needed to keep the battery charged. The performance and fuel economy of the vehicles depend heavily on the applied energy management strategy. There are many energy management strategies used to improve the fuel economy of the vehicle [14]. One strategy is “on/off” or “Thermostat”. Under this strategy the engine will turn on and off based on the SOC status of the battery. There is another strategy called “power split”. Under this “Power Split” strategy the engine and the battery operate at the high efficient operating points. These operating points are selected based on the efficiency maps of the components. As the combustion engine is responsible to provide most of the traction power and also keep the state of charge of the battery (usually 65%) so the power rating of the ICE is higher than that of electric traction motor [14].

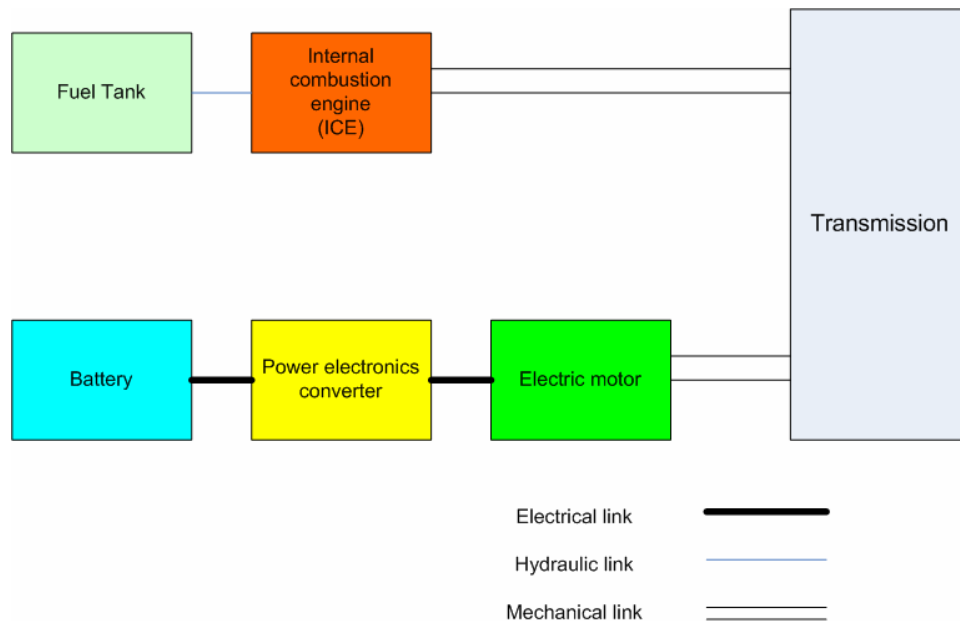

Figure 2-7: Functional block diagram of a parallel hybrid vehicle

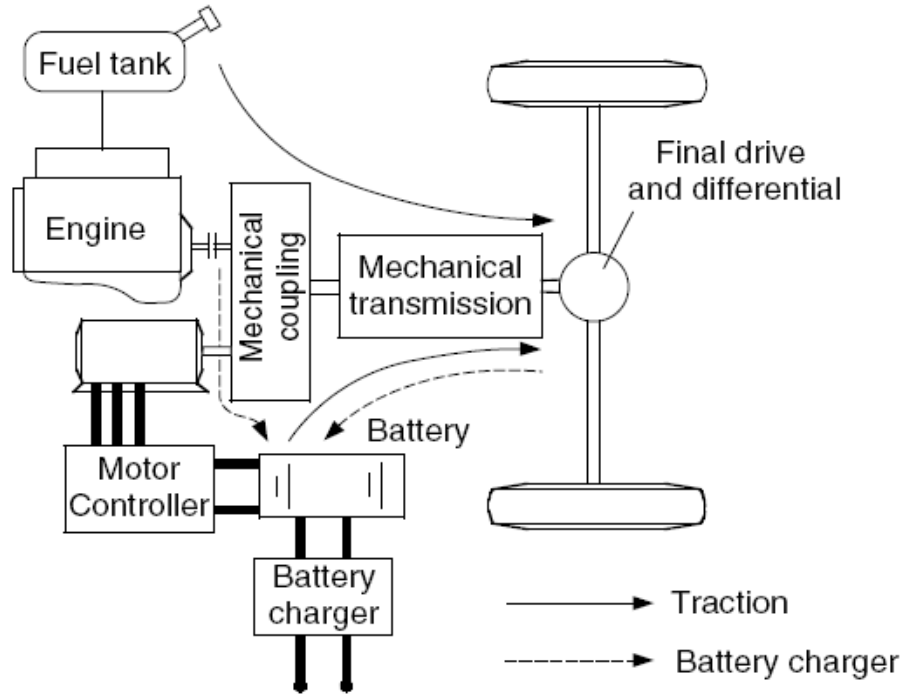

Figure 2-8: Configuration of a parallel hybrid vehicle

3 Simulation and Modeling Principles

Depending on the level of detailness required for the simulation, each component is modeled. The modeling is classified into steady-state, quasi-state and dynamic models. The steady-state and quasi-state models are to do long –term analysis over extended drive cycles. These models are helpful during the design stage when architectural decisions and high-level operating strategies need to be evaluated. The advantage of this modeling is fast computation while the disadvantage is inaccuracy for dynamic simulation. [15], [8].

Dynamic models based on physics of the components are needed to make lower-level comparisons among subsystems and support subsystem design. The dynamic models rely on differential equations of the component and depending on how well the physical system is represented; they show a good accuracy in simulation. In order to have an accurate design for hybrid vehicles and find the power rating of each component the use of dynamic models is beneficial. Power electronic devices which play an important role in hybrid vehicles are working with high switching frequencies. The estimation of the peak rating of them in a vehicular operation system is thus essential.

This can be over come by dynamic modeling which gives more accurate results than steady state models. To calculate the total efficiency of the drive train and consequently getting ratings of components, estimate of conduction and switching losses in power electronic converters is another point which can be simulated by using dynamic models [15].

In Table 3.1 a list of some soft wares which are used for simulation of vehicular power systems is shown.

Table 3-1 List of some soft wares used in hybrid vehicle simulations

Type of Modeling	Steady-State	Dynamic
Name of Software	PSAT	Simplorer
	SIMPLEV	Saber
	ADVISOR	Dymola
	MARVEL	V-Elph
	JANUS	PSIM
	PSAT	PSCAD
	-	VTB
	-	Simulink

Vehicle system modeling can be done for different aspects of interest: Modeling for performance evaluation (acceleration, grade ability and maximum speed); Modeling for prediction, evaluation and optimization of the fuel consumption; Modeling for emission determination; modeling for cost and packaging and different other interests. According to the details of modeling, the models can become more and more complicated and sophisticated. As much as the model becomes complicated, the run time of the simulation increases. There is a trade –off between model detail and run time [8], [15], [5].

3.1 Physics Based Modeling

For detailed dynamic modeling and simulation of hybrid vehicles, physic-based modeling is needed. The dynamic equations of the system are based on physical laws of the system. A series of dynamic equations governing the physical principles of the components are made. These equations are comprised of the state of some system’s physical parameters, physical constants and variables. Resistive Companion modeling technique, RCF, is one of the physics based techniques by which it is possible to get a physics-based model of each component in a modular format [8]. Although this method originates from electrical engineering but it can be used for multidisciplinary modeling applications such as hybrid power train and power systems. Using this sort of modular modeling of each component, shown in figure 3-1, there is the possibility of connecting several modules and do the simulations. In this technique each component is considered as a black box having some terminals to be connected to other modules.

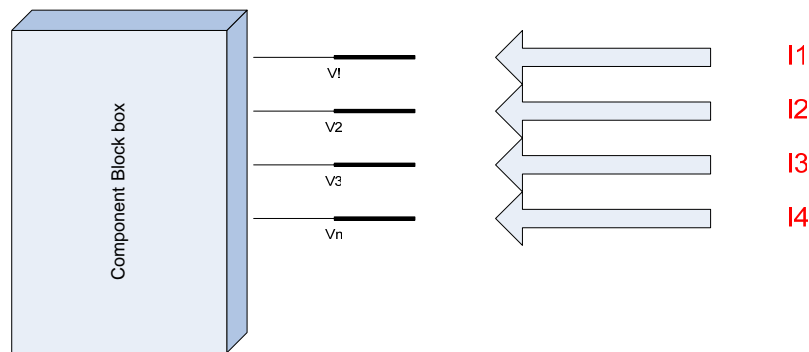

Figure 3-1: RCF modeling

Each terminal has two variables, cross (v_1) and through (I_1) [8]. If the terminals are electrical, one is voltage to a reference point and the other is current going into the terminal as shown in figure 3-1.

The physical dynamic equations of the system are written based on “State Space” equations. Generally each component is modeled by the dynamic equations describing the physical dynamics of the components, (3-1) shows the general equation used for RCF modeling:

$$\begin{bmatrix} I(t) \\ 0 \end{bmatrix} = G [v(t), v(t-h), I(t), I(t-h), y(t), y(t-h), t] \quad (3-1)$$

$$\times \begin{bmatrix} v(t) \\ y(t) \end{bmatrix} - \begin{bmatrix} b_1 [v(t), v(t-h), I(t), I(t-h), y(t), y(t-h), t] \\ b_2 [v(t), v(t-h), i(t), i(t-h), y(t), y(t-h), t] \end{bmatrix}$$

where I is a vector of through variables, V is a vector of across variables, h is time step of the simulation is a vector of state variables, G is Jacobin matrix and b_1 and b_2 are constants depending generally on past history values of through, across variables and internal states and values of these quantities at time instant. The full description of RCF and the modeling of some components like DC machines, DC/DC converters and vehicle dynamics were given in [8].

Once all the components are modeled and connected to each other according to the existing constraints between the modules, the equations could be solved by numerical integration methods, (rectangular, trapezoidal, second order Gears method) and the state variables are found in each time step.

3.2 Numerical Integration Methods

As the state space dynamic equations are solved by numerical integrations there are numerical integration methods available to solve the dynamic equations. Some numerical integration methods like, the rectangular, the trapezoidal, Simpson's, Rounge Kutta's, Gear's, backward Euler's can be found in [6], [8].

Among the mentioned methods, the trapezoidal and rectangular methods are commonly used. In some transient simulation programs like EMTS(Electromagnetic Transient Simulation), the trapezoidal methods are used because of their merits of low distortion and absolute-stability [8]. Most of the transient simulation programs follow up the chart shown in figure 3-2 to converge to the final result.

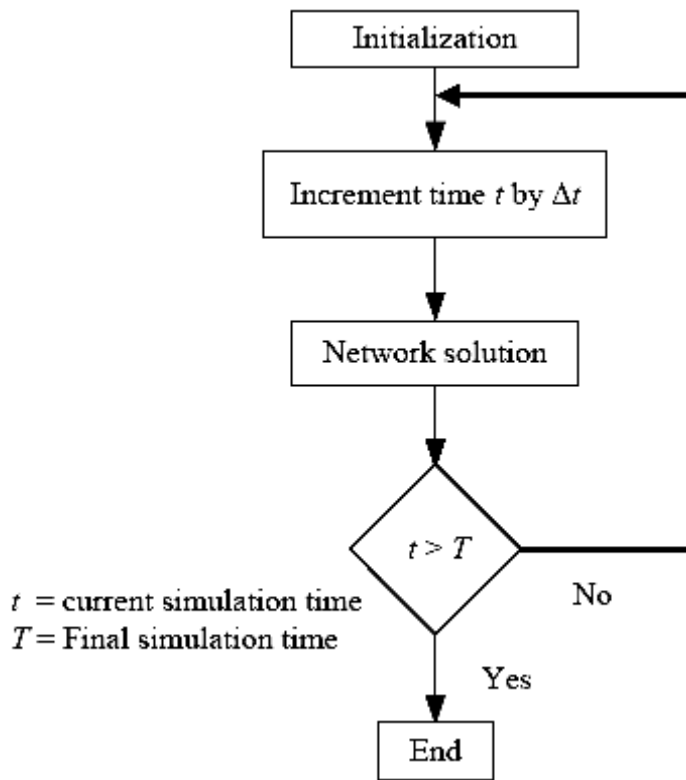

Figure 3-2: EMTS solution flow-chart

Although these methods are really accurate, there will still be some numerical oscillations especially when the power electronic converters with high switching frequencies are used in the simulation. In order to get to high accuracy these numerical oscillations must be considered [8].

In order to mitigate these oscillations there are two techniques: using the trapezoidal technique with numerical stabilizer and using Gear's second order method. In [8] these methods are explained.

4 Vehicle Dynamics Modeling

In order to model the dynamic behavior of the vehicles, all the forces applied to the vehicle should be known. Figure 4-1 shows all the forces applied to the vehicle climbing a grade. It should be noted that here the effect of forces in the longitudinal direction is considered because the movement of vehicle in latitudinal direction is not considerable [12], [13], [10]. By the use of Newton's law all the forces are divided into two forces, the forces in the direction of movement, F_t , which is applied to the wheels of the vehicle, and F_{tr} , the resistance forces that are applied in the opposite direction of the vehicle movement. The Newtons' law is written as:

$$\frac{dV}{dt} = \frac{\sum F_t - \sum F_{tr}}{M_v} \quad (4-1)$$

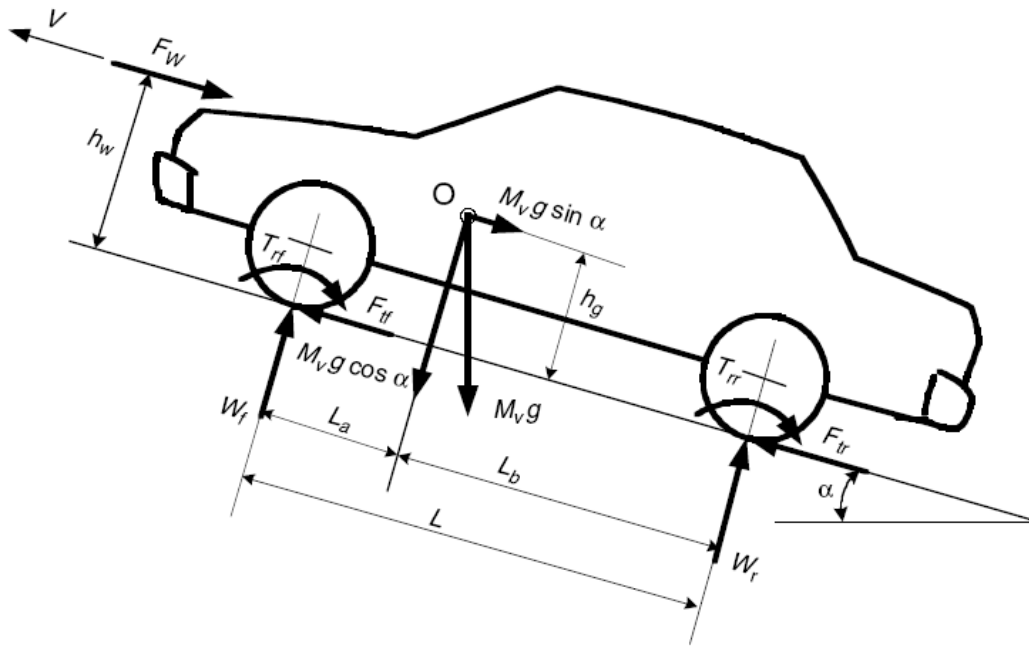

Figure 4-1 Vehicle longitudinal forces

Where V is the vehicle linear speed, M_v is the total weight of the vehicle, F_t is the traction force applied from the tyres to the ground and F_{tr} is equivalent resistance forces. The resistance forces applied to the vehicle are divided into three types. The first one is called rolling resistance which is due to hysteresis in the tyre material. The deflection of the tyre, causes the distribution of the ground reaction forces on the wheel and it is shifted to the lead half of the wheel. The shifted force and the normal load on the wheel cause a torque that resists against the movement of the vehicle [10], [11]. This is shown in figure 4-2.

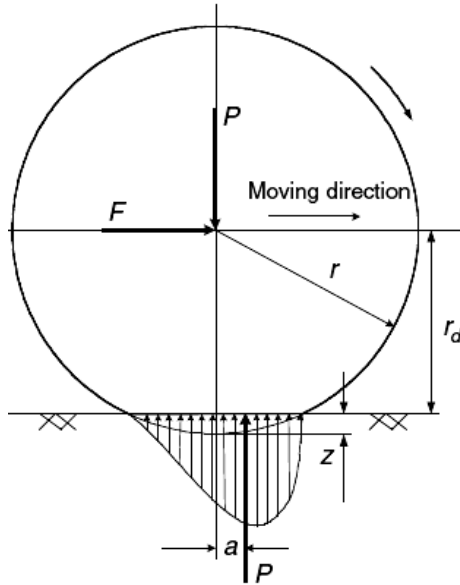

Figure 4-2: The deflection of tyre and rolling resistance

The torque caused by shifted ground reaction force is:

$$T_r = P \times a \quad (4-2)$$

In order to compensate this torque, a torque should be applied to the wheel with the opposite direction so:

$$F_{Rolling} = \frac{Tr}{r_d} = \frac{P \times a}{r_d} = P \times Cr \quad (4-3)$$

Which Cr is called the rolling resistance coefficient and P is the normal load on the wheel. The rolling resistance force is in the opposite direction of the vehicle movement and if the vehicle is climbing a grade the normal force will decrease so the above equation should be multiplied by $\cos\alpha$ which α is the angle of the grade in degree. The rolling resistance of the vehicle is not constant and there are so many factors affecting its value including tyre pressure, tyre temperature, tyre material, road material and vehicle speed of which speed is more important than the other ones. The rolling resistance coefficient will change according to the following equation with speed especially in low speeds for a passenger car [10].

$$Cr = 0.01\left(1 + \frac{V}{100}\right) \quad (4-4)$$

The other resistance is the aerodynamic resistance which is caused because of two things. Shape drag and skin effect. [11], [14], [10]. The aerodynamic force is calculated according to the following equation.

$$F_{Aerodynamic} = 0.5\rho A_f C_d (V + V_w)^2 \quad (4-5)$$

Where ρ is the air density, A_f is the frontal area of the vehicle, C_d is aerodynamic coefficient, V is the vehicle speed and V_w is the wind speed. The aerodynamic coefficient is different for different vehicle shapes. Table 4-1 shows some of the values for different body shapes.

Table 4-1 Drag coefficient for different body shapes

Vehicle Type	Coefficient of Aerodynamic Resistance
Buses	0.6-0.7
Trucks	0.8-1.5
Motorcycles	0.6-0.7
Van body	0.5-0.7
Ponton body	0.4-0.55

The other resistance force is applied when the vehicle is climbing of a grade. As it is shown in Figure 4-1 a force in the opposite direction of the vehicle movement is applied which is found by the following equation:

$$F_{grade} = M_v g \sin(\alpha) \quad (4-6)$$

Where g is the earth gravity and M_v is the total weight of the vehicle. Now that all the forces along the direction of vehicle movement have been clarified, the Newton's equation is formed as:

$$M_v \frac{dV}{dt} = F_t - (F_{aerodynamic} + F_{rolling} + F_{grade}) \quad (4-7)$$

4.1 Wheel Dynamics and Wheel slip

All the force which is applied to the shaft of the vehicle wheel will not be transferred to the ground and consequently become a tractive force. It means that applying a tractive or braking force to the wheel produces a tractive or braking force to the ground based on the slip of the wheel [10], [8], [11], [12]. The slip ratio is defined as:

$$\lambda = \frac{V_{expected} - V_{actual}}{V_{expected}} \quad (4-8)$$

In order to find the slip correctly, it should be considered that during breaking and acceleration slip is found by:

$$\lambda_a = \frac{V_{wheel} - V_{actual}}{V_{wheel}} \quad (4-9)$$

$$\lambda_b = \frac{V_{actual} - V_{wheel}}{V_{actual}} \quad (4-10)$$

Where a and b denotes the slip during acceleration and deceleration respectively. The traction or braking force which is applied to the ground by the tyre is a product of friction coefficient between the tyre and road and the normal load on each wheel.

$$F_i(\lambda) = \mu(\lambda)P_i \quad i = f, r \quad (4-11)$$

Where μ (usually between 0.1 to 0.9) is called the friction coefficient and it changes with the wheel slip, the type of the road and tyre material. P is the normal load on each wheel. i is representing either front wheel or rear wheel. Figure 4-3 shows the curve of the lateral and longitudinal tractive forces versus slip of the wheel. It can be seen that in OA section the increase of longitudinal tractive force is linearly proportional to wheel slip. That is because of the elasticity of the tyre rather than the relative slip between tyre and the ground on the contact area [10]. As the torque is applied on the tyre, it is compressed so the distance that it moves is less than the free rolling of the tyre. As the tractive force increases, the wheel starts slipping with a nonlinear behavior, section AB. Once the drive torque exceeds the maximum tractive force can be produced by tyre, the wheel becomes unstable and the slip increases. It ends up with spinning of the wheel. So in order to apply the maximum force to the ground the slip should be held between 15 to 20 percent to get the maximum tractive force during acceleration. This is achieved by controlling the slip of the wheel. It is also seen in figure 4-3 that there is no tractive force when slip is zero. It should be noted that once a torque is applied to wheel of the vehicle the tyre is deformed depending on the tyre material and road type and a slip is created. It means that having a zero slip during applying torque (driving or braking) is not possible.

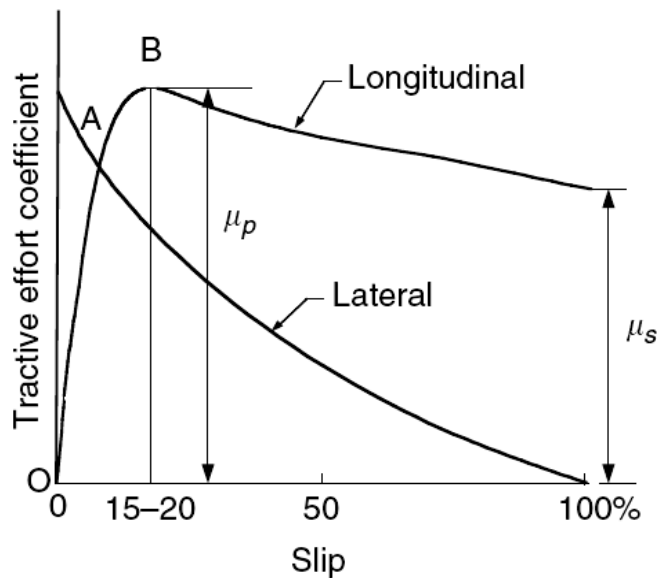

Figure 4-3 Tractive for change with slip of tyre

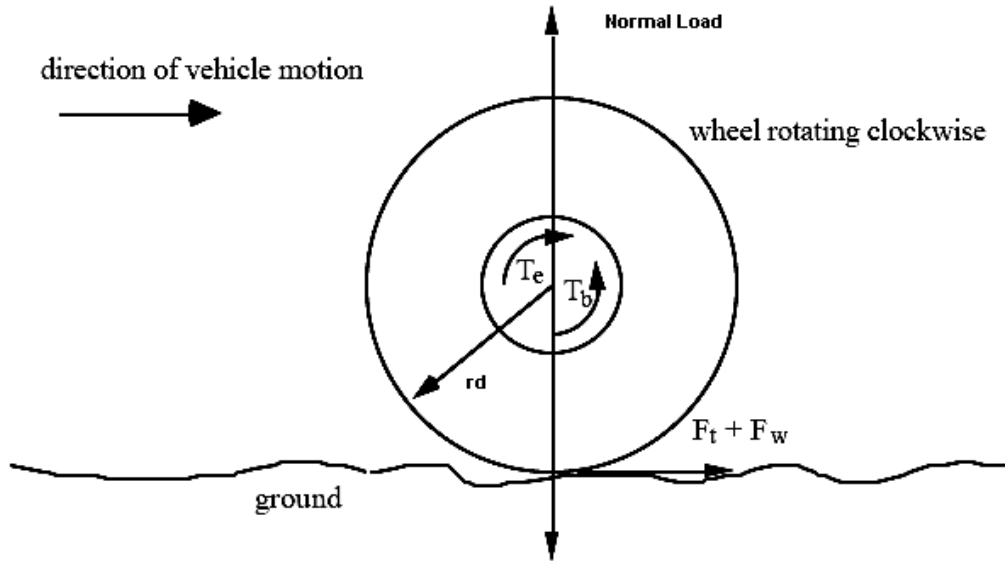

Figure 4-4 Torques and forces on the wheel

The nonlinear behavior of the tractive force on each wheel depends on the nonlinearity of the friction coefficient. The friction coefficient is changing with slip. The dynamics of the wheel is modeled by the following equation:

$$J_w \frac{dW_w}{dt} = T_e - T_b - r_d F_t - F_w r_d \quad (4-12)$$

Where the parameters definition is shown in table 4-1

Table 4-2 Parameters of the wheel dynamics equation

J_w	Wheel inertia
W_w	Wheel speed
T_e	Shaft torque from the engine or motor
T_b	Braking torque
F_t	Tractive force
F_w	Wheel viscous friction
r_d	Wheel radius

As the tractive force is a product of friction coefficient and normal load on each wheel, the normal load on each wheel and the nonlinear behavior of the friction coefficient versus slip should be considered in the model. For this reason two cases will be considered

- Rear-wheeled drive
- Forward-wheeled drive

4.1.1 Normal load on each wheel

The normal load on each rear and front axles for a passenger car depends on the dimension and shape of it. The normal load for a passenger car is found according to the following equation [11].

$$W_f = \frac{L_b}{L} M_v g \cos \alpha - \frac{h_g}{L} (F_{grade} + F_{Aerodynamic} + M_v g C_r \frac{r_d}{h_g} \cos \alpha + M_v \frac{dV}{dt}) \quad (4-13)$$

$$W_r = \frac{L_a}{L} M_v g \cos \alpha - \frac{h_g}{L} (F_{grade} + F_{Aerodynamic} + M_v g C_r \frac{r_d}{h_g} \cos \alpha + M_v \frac{dV}{dt})$$

Where h_g is the height of vehicle center of gravity from the ground, L_a and L_b are the distances of the front axle and the rear axle from the center of gravity respectively. L is the total distance between front and rear axles. The dimensions are shown in figure 4-1. As in passenger vehicles the center of application of aerodynamic force, h_w and the gravity force are near the same height, h_g , so the above equations are simplified to

$$W_f = \frac{L_b}{L} M_v g \cos \alpha - \frac{h_g}{L} (F_t - F_r (1 - \frac{r_d}{h_g})) \quad (4-14)$$

$$W_r = \frac{L_a}{L} M_v g \cos \alpha - \frac{h_g}{L} (F_t - F_r (1 - \frac{r_d}{h_g}))$$

Where F_t is the sum of front and rear tractive forces and F_r is the sum of front and rear rolling resistance. r_d is the effective radius of the wheel.

4.1.2 Friction coefficient and slip modeling

Experimental studies have produced several clearly defined friction/slip characteristics between the tyre and road surface for a variety of different driving surfaces and conditions [12]. For the purposes of simulation, four types of road condition are modeled:

- Normal: The road is dry and maximum traction is theoretically possible.
- Wet/Raining: Overall traction is reduced by about 20 %.
- Snow: Un-packed snow lies on the road surface. Maximum traction reduced by 65 %.
- Ice: Packed frozen snow and black ice lie on the road surface. Highly dangerous – maximum traction reduced by 85 %.

Graphically, these four conditions are shown in figure 4-5 below:

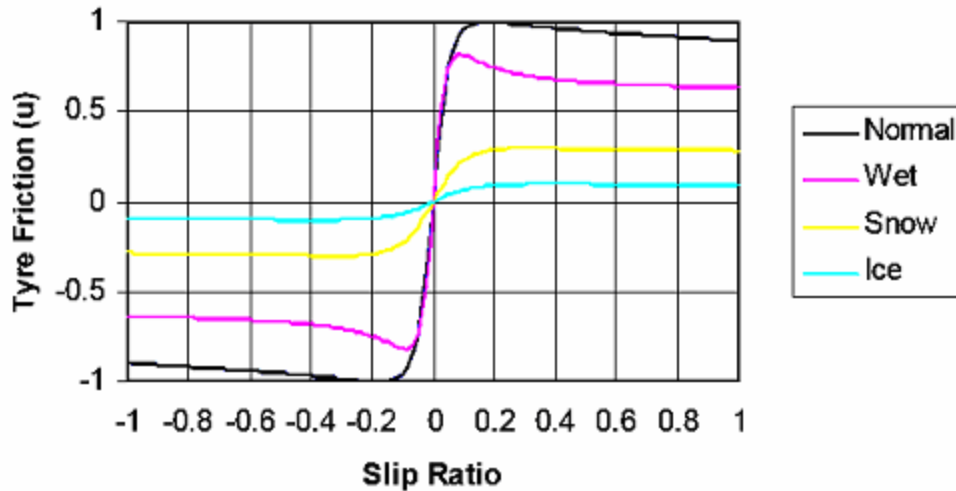

Figure 4-5 Friction coefficient change with slip for different road types

For a given set of tyre test data, several analytical models exist to analyze and simulate these relationships. The most popular of which is the Pacejka “magic” model. The Pacejka model is defined mathematically as follows:

$$\mu_i(\lambda_i) = D \sin(C \arctan(B\lambda_i - E(B\lambda_i - \arctan(B\lambda_i)))) \quad i = r, f \quad (4-15)$$

The model defines in excess of 40 constants that are determined from the given set of experimental data, and the overall model coefficients B , C , D and E are then calculated from a combination of these constants. The required model coefficients to produce the slip/friction relationships as shown in the graph above were determined from some test data and are shown in table 4-3:

Table 4-3 Pacejka coefficients for different road types

Pacejka coefficient				
Surface	B	C	D	E
Dry Tarmac	10	1.9	1	.97
Wet Tarmac	12	2.3	.82	1
Snow	5	2	.3	1
Ice	4	2	.1	1

As mentioned before in the simulation of the tyre the drive torque applied the wheel should not exceed the maximum tractive force can be produced by tyre otherwise the model becomes unstable and some chatterings are seen in the simulation.

The maximum tractive force which can be applied to the front and rear wheels is the multiplication of the friction coefficient and the normal load on the wheel. For a front wheel driven vehicle it is [11]:

$$F_{t_{\max}} = \mu W_f = \mu \left(\frac{L_b}{L} M_v g \cos \alpha - \frac{h_g}{L} (F_{t_{\max}} - F_r (1 - \frac{r_d}{h_g})) \right) = \frac{\mu M_v g \cos \alpha [L_b + C_r (h_g - r_d)] / L}{1 + \mu h_g / L} \quad (4-16)$$

And for rear wheel driven vehicle is:

$$F_{t_{\max}} = \mu W_r = \mu \left(\frac{L_a}{L} M_v g \cos \alpha - \frac{h_g}{L} (F_{t_{\max}} - F_r (1 - \frac{r_d}{h_g})) \right) = \frac{\mu M_v g \cos \alpha [L_a + C_r (h_g - r_d)] / L}{1 + \mu h_g / L} \quad (4-17)$$

If the tractive force applied on the wheels exceeds this maximum force the wheel starts spinning.

4.2 Transmission

In order to transfer the mechanical torque produced by the traction motor and engine to the wheels of the vehicle there are some parts in between that are called transmission part. It includes, clutch or torque converter, gear box, final drive, differential and drive shaft. It should be noted that most of the above transmission parts may not be used in a typical hybrid or electric vehicle. For example the gear box could be replaced by a continuous vehicle transmission (CVT) part. As the ICE or the electric traction motor has a limited speed, by using a gear box this limitation could be further increased. Figure 4-6 shows the extended operation characteristic of a typical 5 ratio gear box connected to a combustion engine.

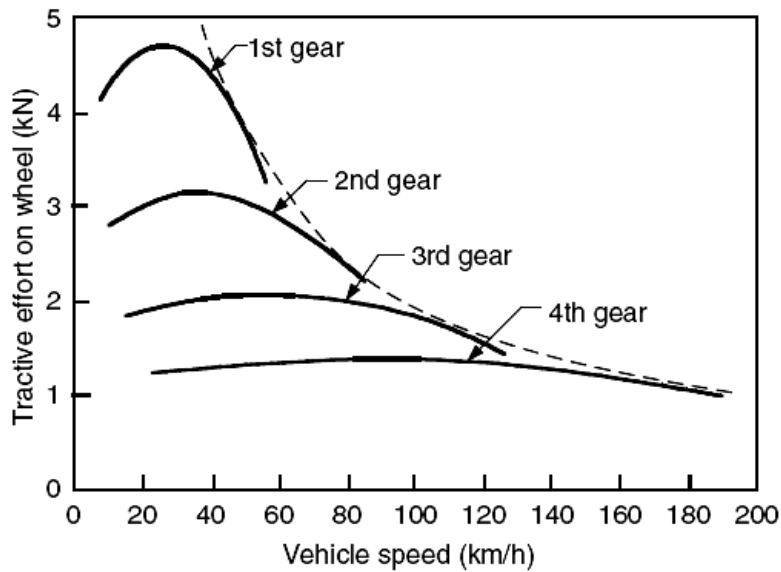

Figure 4-6 Tractive effort of internal combustion engine and a multi-gear transmission vehicle vs. vehicle speed

The gear box consists of different gears which transmit speed and torque of the traction system (ICE or electric motor) to the wheels. The clutch is used to connect different gears to the shaft of the traction system. The final drive is also contains different gears that further increases the speed limitation of the traction system. It means that by applying low ratio gears the demand for higher vehicle speeds is met.

For the modeling of the transmission system two factors must be considered:

- Gear ratio
- Transmission efficiency

Having the transmission efficiency and gear ratio the equivalent load torque on the shaft of the traction system is calculated. The torque which is applied by the traction source (electric motor or ICE) on the wheels is:

$$T_{wheel} = N_g \times N_d \times \eta_{transmission} \times T_t \quad (4-18)$$

Where N_g and N_d are ratio of gear box and drive line system respectively and η is the transmission total efficiency of the transmission line including clutch, gear box and drive line. T_t is the torque of the traction system.

The tractive force on the wheels is:

$$F_t = \frac{T_{wheel}}{r_d} = \frac{N_g \times N_d \times \eta_{transmission} \times T_t}{r_d} \quad (4-19)$$

The longitudinal speed of the vehicle also can be found by the following equation in terms of vehicle speed:

$$V = \frac{W_t \times r_d}{N_g \times N_d} (m/s) \quad (4-20)$$

Having modeled the dynamics of the vehicle the torque coming from the engine or electric motor can easily be connected to the vehicle dynamics model as an input.

5 Battery Modeling

As batteries play an important role in hybrid electric vehicles there should be a good model in the simulation tool, representing the actual behavior of the battery. There are many types of batteries and many factors that affect battery performance. To predict the performance of batteries, different mathematical models exist. None of these models are completely accurate nor do any include all necessary performance effecting factors.

Factors that affect battery performance include:

- State of charge (SOC)
- Battery storage capacity
- Rate of charge/discharge
- Temperature
- Age/shelf life

According to what is needed in the simulation, a model for battery is constructed. Generally the models proposed by several scientists could be categorized into 5 groups:

- Electrochemical battery models
- Equivalent circuit battery models
- Dynamic Lumped parameters battery model
- Hydrodynamic, finite element type models
- Tabulated battery data used models.

Here two methods that are commonly used in the simulation of hybrid vehicles are introduced and a nonlinear model to use in hybrid vehicle simulations is given.

5.1 Electrochemical battery models

The simplest models are based solely on electrochemistry. These models ignore thermodynamic and quantum effects. Consequently, while these models can predict energy storage they are not able to model phenomena such as the time rate of change of voltage under load nor do they include temperature and age effects [27].

5.1.1 Peukert equation

The Peukert equation, (5-1), is a convenient way of characterizing cell behavior and of quantifying the capacity offset in mathematical terms. This is an empirical formula which approximates how the available capacity of a battery changes according to the rate of discharge [21], [22].

$$I^n \times T_i = C \quad (5-1)$$

Where

- I = discharge current [amp]
- n = battery constant ($n=1.35$ for typical lead-acid batteries)
- T_i = time to discharge at current I [seconds]
- C = theoretical capacity of the battery [ampere hour]

Equation 5-1 shows that at higher currents, there is less available energy in the battery. The Peukert Number is directly related to the internal resistance of the battery. Higher currents mean more losses and less available capacity. The value of the Peukert number indicates how well a battery performs under continuous heavy currents. A value close to 1 indicates that the battery performs well; the higher the number, the more capacity is lost when the battery is discharged at high currents. The Peukert number of a battery is determined empirically. For Lead acid batteries the number is typically between 1.3 and 1.4.

Figure 5-1 shows that the effective battery capacity is reduced at very high continuous discharge rates. However with intermittent use the battery has time to recover during quiescent periods when the temperature will also return towards the ambient level. Due to this potential for recovery, the capacity reduction is less and the operating efficiency is greater if the battery is used intermittently as shown by the dotted line. Note that this is the reverse of the behavior of an internal combustion engine which operates most efficiently with continuous steady loads. In this respect electric power is a better solution for delivery vehicles which are subject to continuous interruptions.

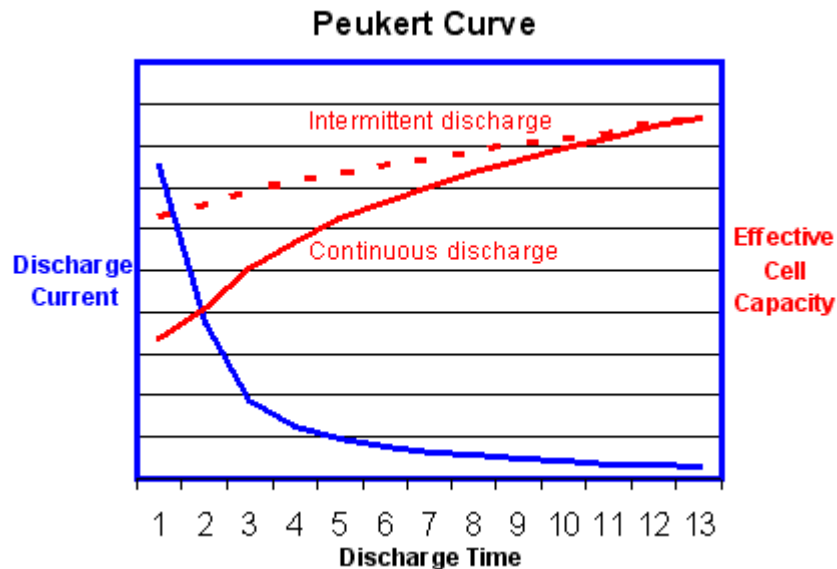

Figure 5-1 Peukert curve and capacity change of battery versus discharge current

5.1.2 Battery capacity and discharge current

The Peukert relationship can be written to relate the discharge current at one discharge rate to another combination of current and discharge rate:

$$C_1 = C_2(I_2 / I_1)^{(n-1)} \quad (5-2)$$

Where

- C = capacity of the battery
- Subscripts 1 and 2 refer different discharge-rate states

From this relationship the state of charge (SOC) at a constant discharge rate is:

$$SOC = 1 - (I \times t) / C \quad (5-3)$$

For non-constant discharge rates the above equation must be modified and evaluated in small time steps:

$$\Delta SOC = I_2 \Delta t / 3600 / C_1 (I_2 / I_1)^{(n-1)} \quad (5-4)$$

In the equation 5-4, it is assumed that a given combination of current and discharge rate (C_1 and I_1) is known. Given the current at the present time step (I_2), the corresponding discharge rate is calculated using 5-2 for C_2 and plugged into an incremental form of equation for SOC .

5.2 Shepherd Model Equation

The Shepherd model is perhaps the best known and most often used battery model for Hybrid vehicle analysis. The model describes the electrochemical behavior of the battery directly in terms of voltage and current. It is often used in conjunction with the Peukert equation to obtain battery voltage and state of charge given power draw variations [23]:

$$E_t = E_o - R_i I - K_i (1 - q) \quad (5-5)$$

Where

- E_t = battery terminal voltage [volts]
- E_o = open circuit voltage of a battery cell when fully charged [volts]
- R_i = internal (ohmic) resistance of the battery [ohms]
- K_i = polarization resistance [ohms]
- C = battery capacity [ampere-hour]
- I = instantaneous current [amps]
- q = accumulated ampere-hours divided by full battery capacity.

The fractional state of charge is then found via Peukert's equation.

5.3 Unnewehr Universal Model

The Shepherd model is based on constant current discharges at low current levels. The Shepherd equation tries to find the cut-off point beyond which the terminal voltage

decreases very rapidly. In electric vehicles, batteries are not usually used at these extreme states of depth of discharge so Unnewehr and Nasar [24] suggest simplifying the Shepherd equation as

$$E_t = E_o - R_i I - K_i q \quad (5-6)$$

The open circuit voltage or no-load battery terminal voltage for this model is simply:

$$E_{oc} = E_o - K_i q \quad (5-7)$$

Unnewehr and Nasar go on to define an equivalent internal resistance function:

$$R_i = R_o - K_R q \quad (5-8)$$

Where

- R_o = total internal resistance of a fully charged battery
- K_R = experimental constant

This equation attempts to model the variation in R_i with respect to **SOC**. By combining this equation with **Power=VI**, one can create the following relation to calculate current during discharge:

$$I = (E_{oc} - \sqrt{(E_{oc}^2) - 4R_i p}) / (2R_i) \quad (5-9)$$

And during charge as:

$$I = (-E_{oc} - \sqrt{(E_{oc}^2) + 4R_i p}) / (2R_i) \quad (5-10)$$

The max power, p , can be computed as:

$$p_{\max} = E_{oc}^2 / (4R_i) \quad (5-11)$$

5.4 EQUIVALENT CIRCUIT BATTERY MODELS

These models are modeling the batteries in the shape of electronic circuits. For example, the capacity of the battery is modeled by a capacitor and the effect of the voltage deviation in the terminal of the battery caused by temperature, state of the charge is modeled by variable resistors and controlled voltage sources. There are so many models proposed by different scientists but the most commonly used are Thevenin battery model, linear electric model and nonlinear electric models.

5.4.1 Thevenin battery model

Another basic battery model describes a battery with an ideal battery voltage (E_{oc}), internal resistance (R), a capacitance (C_o) and over voltage resistance (R_o) [27].

The disadvantage of this model is that all the parameters in this model are constant but in reality these parameters are changing according to temperature and state of the charge of the battery.

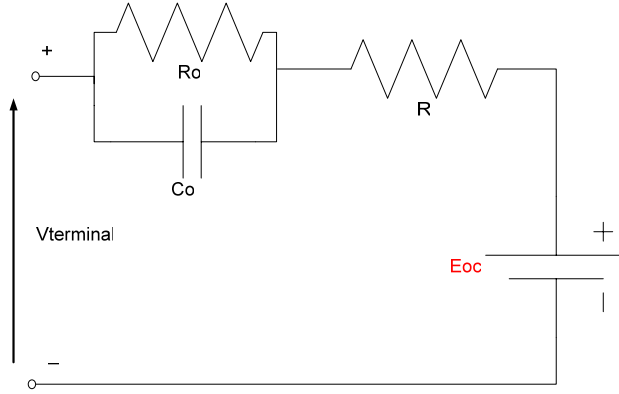

Figure 5-2: Battery Thevenin model

A new approach to evaluate batteries is a modified model for Thevenin model [16]. The modified model of Thevenin mode is based on operation over a range of load combinations. The electrical equivalent of the proposed model is as depicted in figure 5-3.

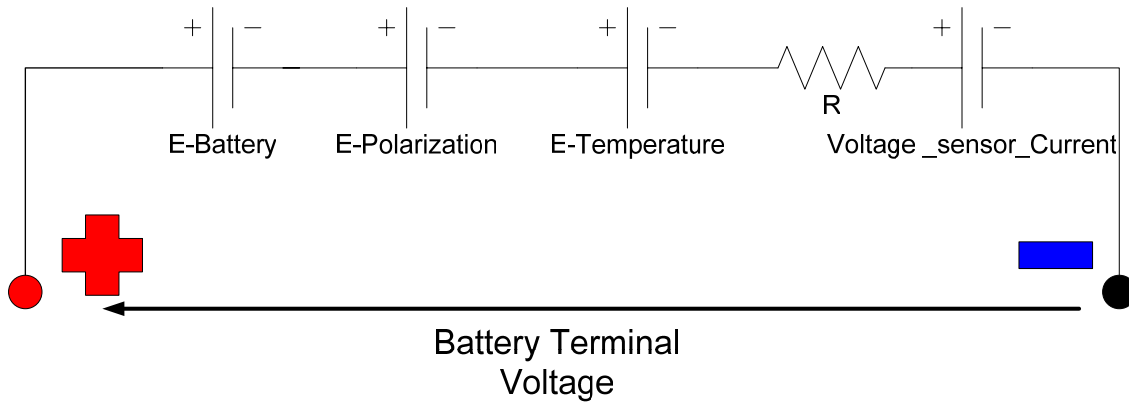

Figure 5-3: Modified Thevenin model

In figure 5-3, the main circuit model consists of the following five sub-circuits:

- (a) E-battery: This is a simple DC voltage source designating the voltage in the battery cells.
- (b) E-polarization: It represents the polarization effects due to the availability of active materials in the battery.
- (c) E-Temperature: It represents the effect of temperature on the battery terminal voltage.
- (d) R: This is the battery's internal impedance, the value of which depends primarily on the relation between cell voltage and state of charge (*SOC*) of the battery.
- (e) Voltage_sensor_current: This is basically a voltage source with a value of 0V. It is used to record the value of battery current.

Thus, this simulation model is capable of dealing with various modes of charge/discharge: It is comparatively more precise and can be extended for use with Ni-Cd and Li-ion batteries, which could be applied to hybrid electric vehicles and other traction applications [16]. Only a few modifications need to be carried out in order to vary the parameters, such as load state, current density, and temperature.

5.4.2 Linear dynamic model

An improved variant of the Thevenin model is a linear electrical battery model [25]. This model is one step ahead of the Thevenin model. It models the behavior of the battery during overvoltage and self discharge of the battery. This model, shown in figure 5-4, is more accurate than the Thevenin model but it still does not consider the change of the value of parameters according to different operating conditions.

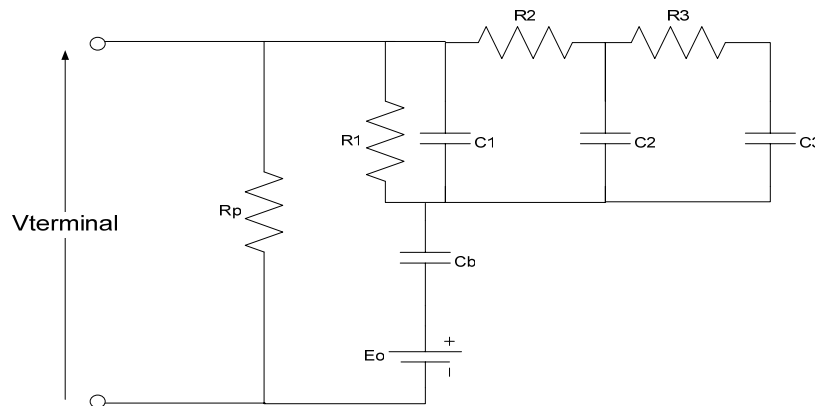

Figure 5-4: Battery linear model

5.4.3 Nonlinear dynamic model

Having reviewed different modeling methods, it was decided to model the battery by a more realistic dynamic model by modification of the Thevenin model. In this model all the parameters are affected by state of charge of the battery and temperature. This model takes into account the variation of different parameters with state of charge of the battery, temperature and discharge rate. The model has been shown in figure 5-5. As can be seen in the model it is using two different internal resistances during charging and discharging. The diodes in the model are ideal and they are used to bypass internal resistances during charging or discharging. There is a capacitor in the model which represents the transient behavior of the battery.

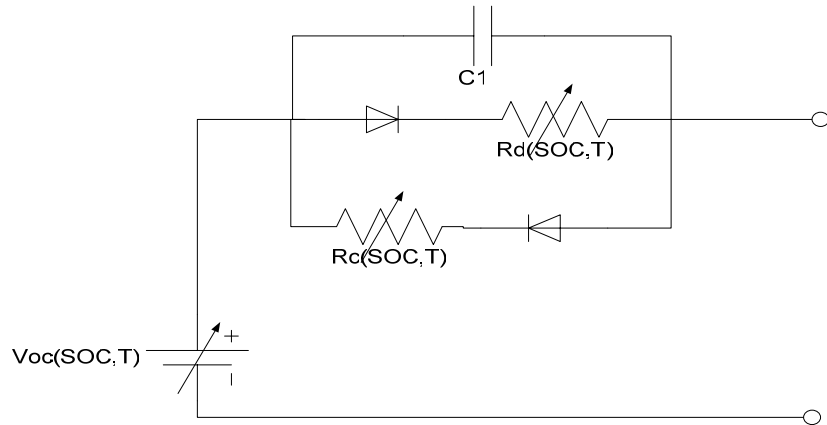

Figure 5-5: Battery nonlinear model

The circuit is composed of two sections:

- The battery open circuit voltage which is represented by a controlled dc voltage source and its magnitude is changed by state of charge and temperature.
- Internal resistance is modeled by R_c and R_d representing charging and discharging resistances respectively. The value of these resistances is changed by the state of charge and temperature as well. Since during charging and discharging the battery has two concentrations of available reactants so by using two ideal diodes different resistances are put in the circuit during charge and discharge.

The model is nonlinear in the sense that the elements V_{OC} , R_d and R_c are not constants but are modeled as a function of state of charge and temperature. Only C_l has been considered constant although it is changing with state of charge but its change is not considerable. [17], [18], [19]. Figure 5-6 shows the chart how the look up tables are updated in each simulation time step.

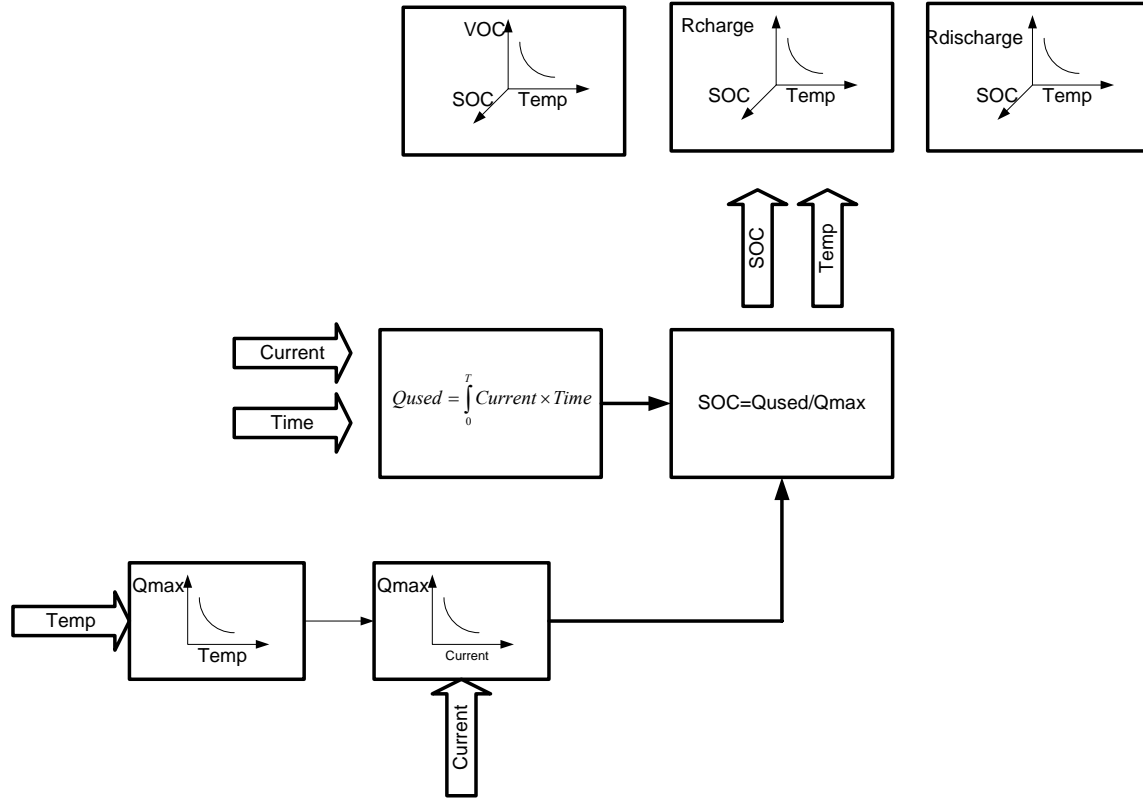

Figure 5-6 Battery model updating chart

In order to find the state of charge of the battery, the total capacity (A.h) of the battery should be considered. As this capacity is changing with discharge/charge current and temperature, this change also must be considered in each simulation time step.

5.5 Thermal modeling of the battery

Since the equilibrium potential of the battery is temperature dependent, the temperature must be resolved dynamically so that it is available for computation of the potential during each time step. The temperature change of the battery is governed by the thermal energy balance described by:

$$mc_p \frac{dT(t)}{dt} = R_{int} i(t)^2 - h_c A [T(t) - T_a] \quad (5-12)$$

Where A is the total area which thermal energy can be transferred from the battery to the air, C_p the heat capacity of battery, h_c is the cooling coefficient, R_{int} is the internal resistance of battery which is different during charging and discharging and T_a is the ambient temperature. It must be noted that heat generation in the battery and consequently entropy changes in the battery changes the heat capacity but in the thermal model because this effect is not considerable it is ignored [28].

5.6 Parameters measurement

5.6.1 Open circuit voltage

In order to measure the open circuit voltage in different state of charges and temperatures, a constant current is drawn from a fully charged battery in time intervals. After each time interval the open circuit voltage of the battery is measured according to the state of charge of the battery, shown in figure 5-6. Once the open circuit voltage gets to a minimum value as given by the manufacturer [26] the battery is totally discharged and state of charge is zero. Doing some tests on one cell of 6 A.h Lithium-ion batteries at the HVDC research center the battery open circuit voltage versus state of charge was measured. The measurement results are shown in figure 5-7. The test was done in three temperatures and with a low current.

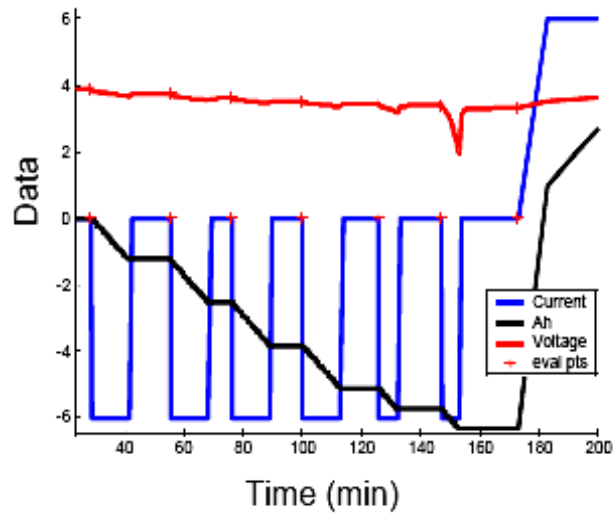

Figure 5-7 Test procedure for measurement of open circuit voltage

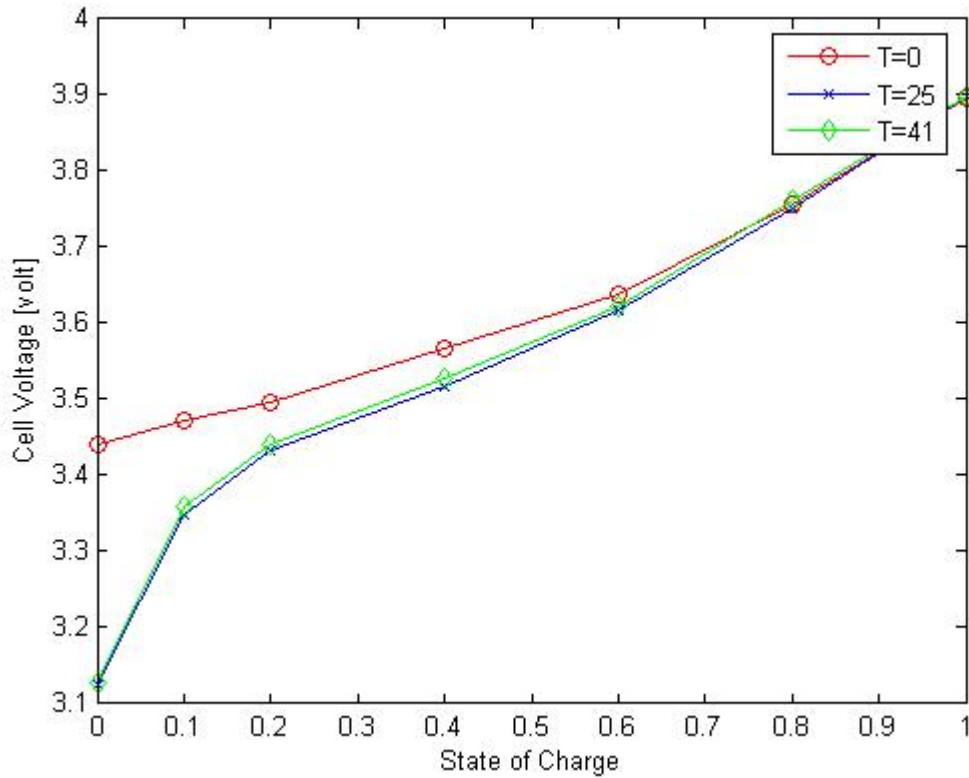

Figure 5-8 Battery open circuit voltage versus state of charge

5.6.2 Charging and Discharging Resistances

In order to find the charging and discharging resistances, a circuit like the one shown in figure 5-8 is used. In each open circuit voltage a resistor is connected to the terminals of the battery. Knowing the terminal voltage, open circuit voltage and current of the battery, the internal resistance of battery is measured as:

$$R_{int} = R_{load} \cdot (V_{OC} - V_b) / V_b \quad (5-13)$$

By measuring open circuit voltage and terminal voltage in different states of charges and temperatures the curves, shown in figures 5-9 and 5-10, are obtained.

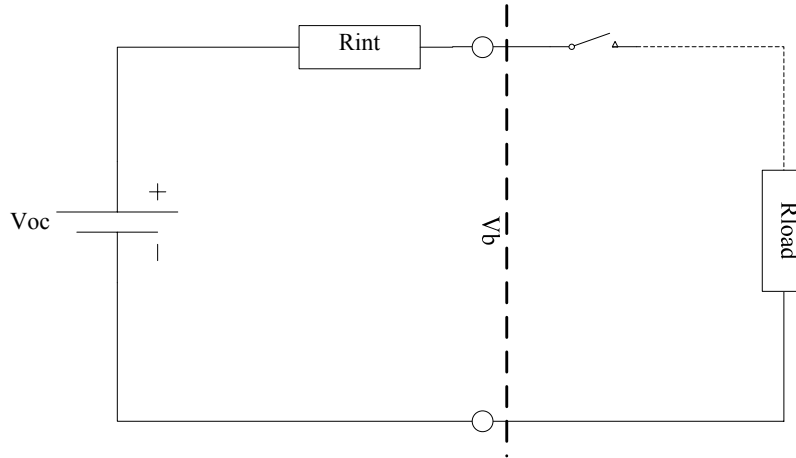

Figure 5-9 Circuit for determining of open circuit voltage

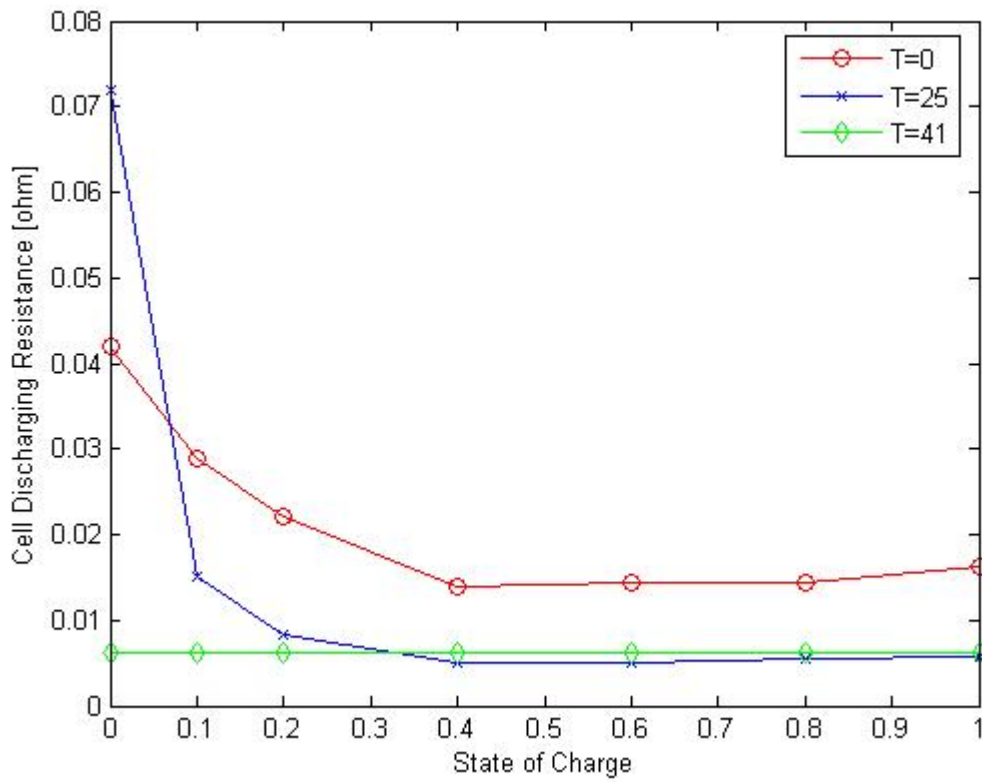

Figure 5-10 Discharge resistance versus state of charge

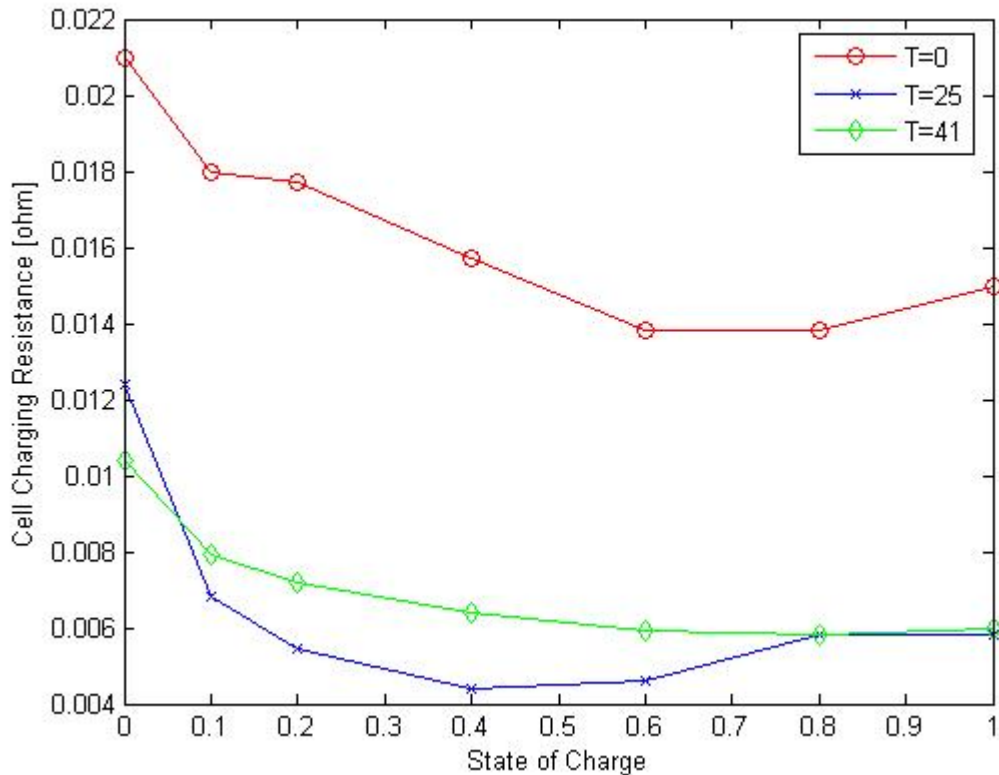

Figure 5-11 Charging resistance versus state of charge

As can be seen the internal resistances of the battery are increased as the state of charge of the battery decrease. In higher temperatures the internal resistance is less because of the free movement of the electrons in the electrolyte.

5.6.3 Capacitor

In order to consider the transient behavior of the battery, the value of the capacitor must be measured. To find the capacitor, the voltage transient happening during transition from one load to another load is observed. A circuit model as shown in figure 5-11 is used. At first load R_1+R_2 is connected. Then the load is switched to only R_1 . The voltage behavior of battery is shown in figure 5-12. The transient time between V_1 , when R_1+R_2 is connected and V_b , when R_1 is connected is measured, τ , and according to following equation the value of capacitor is calculated.

$$0.63\tau = (R_1 + R_{int})C_1 \quad (5-14)$$

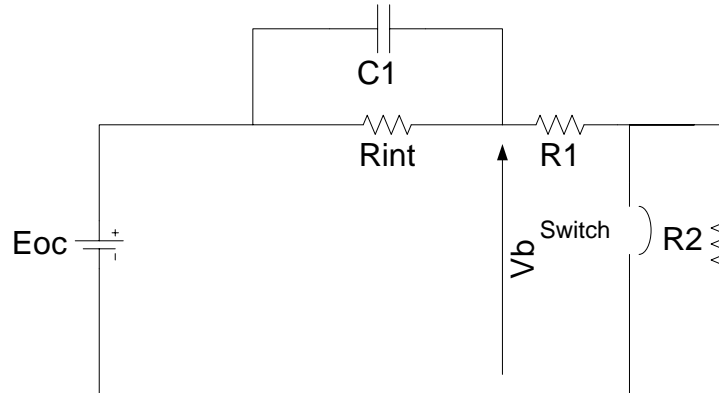

Figure 5-12 Circuit to determine battery capacitance

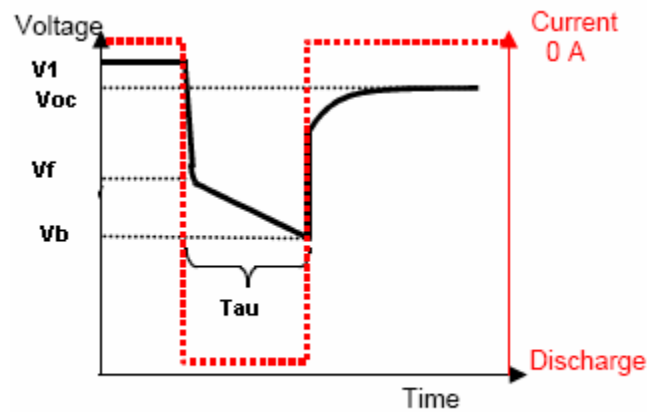

Figure 5-13 Transient behavior of battery terminal voltage during load change

5.6.4 Battery capacity

As the capacity of the battery depends on the temperature and the discharge current [17], in the model, the temperature dependence of battery capacitance is estimated by the data available from the manufacturer and changes in capacity is applied by look up tables. The capacity of the battery is used to find the state of charge of the battery which is explained in chapter 7.

6 Engine, electric machine and control system modeling

6.1 Electric motors

There are different types of electric motors which are commonly used in the drive train of hybrid electric vehicles. Having a high efficiency compared to internal combustion engines, they have become good traction components in hybrid and electric vehicles. DC motors, permanent magnet synchronous motors (PMSM) and switched reluctance motors have been shown good performance to be used in vehicular applications [2]. With introduction of developed control methods like vector control they have become really popular in vehicle industry. So the modeling of electric motors is essential for a vehicle simulation tool.

Modeling of electric motors could be made in different forms. In some cases the behavior of the motor is modeled by look-up tables collected from experimental tests on the efficiency maps of motor [2], [1], [7]. The typical efficiency map of an electric motor is given in different operating points in terms of speed and torque as shown in figure 6-1.

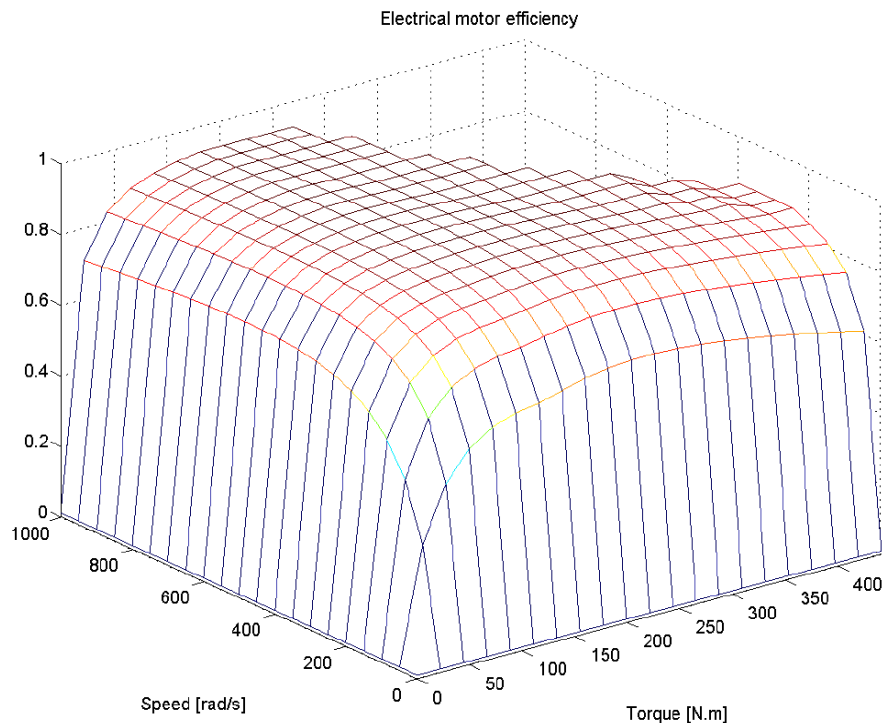

Figure 6-1 Efficiency map of a typical PMSM

There are some models which use the dynamic equation of motor [9] and they are modeled by state-space equations. If in a drive train the dynamics of every component is in demand then the dynamic models are a good choice. Having the dynamic model of electric motors the field oriented control of electric machines can be implemented. In figure 6-2 some dynamic models of electric machines used in hybrid electric vehicles are shown.

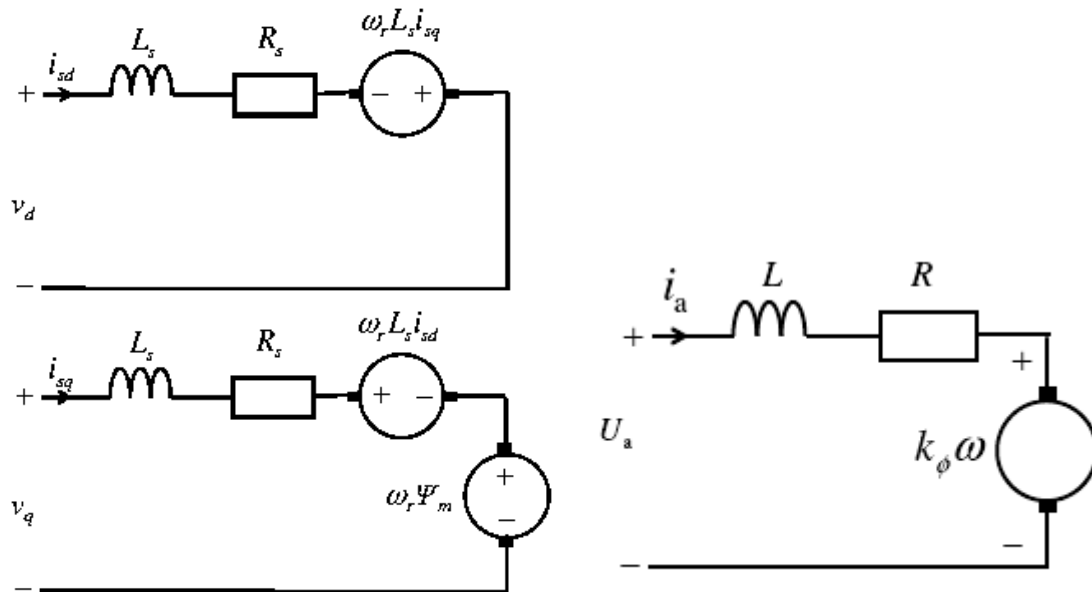

Figure 6-2 Dynamic models for PMSM (left) and DC motor (right)

As mentioned in Chapter 3 depending on the aim of the simulation and the level of accuracy and details desired, there is the possibility to use more detailed models for electric motors than efficiency maps. The method of using look up tables has been used in this thesis. The static equation of a PMSM electric machine is written in Matlab and from the considered copper losses and iron losses in the machine, the efficiency map of the machine is derived [9].

6.2 Internal combustion engine

In order to model the behavior of the engine there are some methods. In some models an internal combustion engine can be described with maps, e.g. an efficiency map. Such a map describes the engine power output relative to the fuel power input as a function of the engine speed and shaft torque. To use look up tables for the modeling of the bus engine the efficiency maps of a diesel engine with the specifications written in table 6-1 was studied.

Table 6-1 Diesel engine specifications

S.No	Parameter	Specification
1	Engine Type	Diesel,D-2
2	Compression ratio	17.2:1
3	Displacement	5.88 Liters

4	Idle speed	840 rpm
5	Peak power	150 kw at 1600 rpm
6	Charging system	Turbo charging, charge air cooled

Results based on the test data from the engine efficiency map and operation characteristic of the engine are shown in figures 6-3 and 6-4.

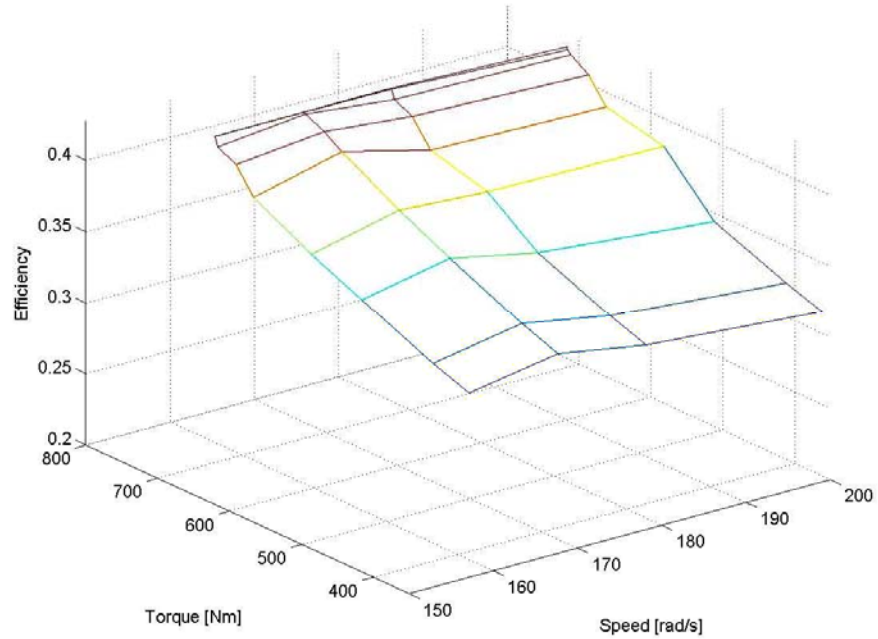

Figure 6-3 Engine efficiency map

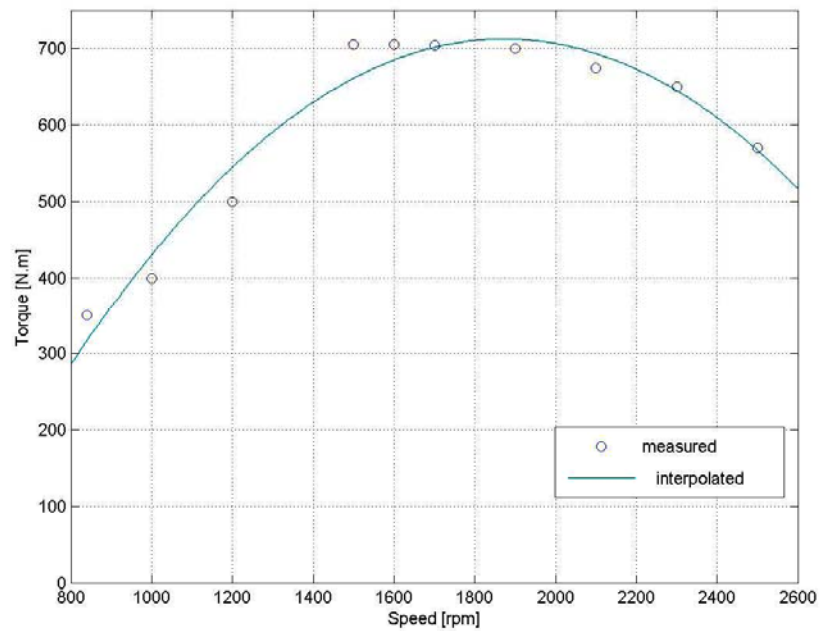

Figure 6-4 Engine torque & speed characteristic

When the power requirement varies, so does the operating point. Since the map is a description of the combustion engine performance in stationary operation, the transient behavior of the engine is not considered but with a kind of acceptable approximation the transient change in operating point could be modeled by a first order low pass filter in the control system with the time constant of 1.5 seconds. These transient behaviors are caused by:

- Acceleration and deceleration of gas and exhaust flow plugs
- Wall-wetting phenomenon

There are some other dynamic modelings of the engine which can be used for transient simulations [3].

6.3 Control system

One of the most important parts in the simulation of hybrid vehicles is the control system. In hybrid vehicles as there are at least two energy sources, so the power needed for traction, recharging of batteries and ultra capacitors auxiliary loads must be provided by energy sources. The way that this needed power is shared between sources called energy management which has some effects on the performance of the vehicle. Using different control strategies, the fuel consumption and performance of the hybrid drive train could be changed [14].

7 Modeling in Simulink/Matlab

Once the analytical approaches have finished regarding each component used in a typical hybrid drive train it is required to make a model for any of the components in a simulation area. All the components including battery, engine, electric motor and generator, vehicle dynamics, tyre, automatic driver, driving cycles and control system are modeled in Matlab/Simulink. In the following, the modeling process in Matlab for each part is explained.

7.1 Battery

Once all the parameters including charging and discharging resistances, open circuit voltage of the battery versus state of charge and temperature were measured by experiments, those values are used as look up tables. The model consists of three parts: SOC calculation block, voltage calculation and thermal modeling block shown in figure 7-1. The input of the model is the requested power out of the battery. According to the requested power using analytical solutions the current and terminal voltage of the battery is calculated. As mentioned in chapter 4 during modeling in respect to the direction of the power, charging and discharge resistances are selected. As current is drawn out of the battery the total charge drawn out of the battery is calculated. Based on the internal temperature coming from the thermal model and current, the maximum capacity of the battery (A.h) is corrected by look-up tables. The charge drawn out of the battery is divided by the maximum capacity of battery in a certain current and temperature gives the state of charge of the battery.

In each time step the parameters are updated according to temperature and state of charge. The maximum charging and discharging power, terminal voltage and current is limited in the model.

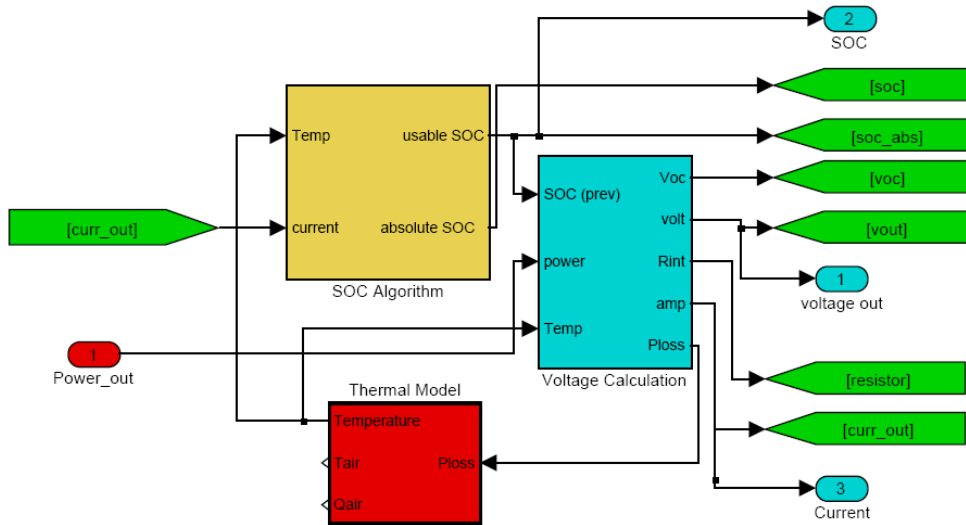

Figure 7-1 Block diagram of battery model

7.1.1 Thermal model

As the battery is charged or discharged, a part of the energy is dissipated in the internal resistance. Calculating the power dissipated in the battery and using (5-12) gives the internal temperature of the battery. In this model the effect of cooling is also considered. As the temperature of the battery increases to a certain temperature, a part of the heat generated in the battery is removed by the cooler. As the temperature exceeds the set value the thermal resistance of the whole system is decreased. The thermal block diagram is shown in figure 7-2.

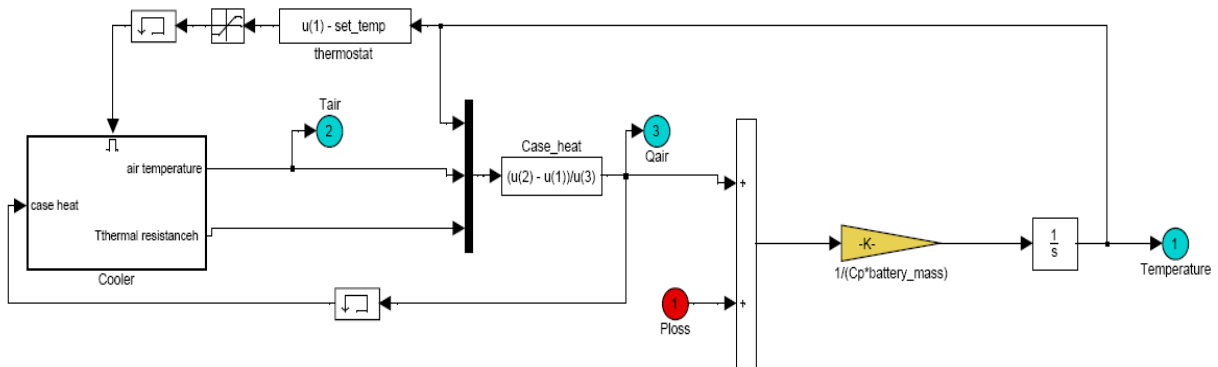

Figure 7-2 Battery thermal model block diagram

7.2 Vehicle dynamics

Based on the analytical equations explained in Chapter 3, the vehicle dynamics model is created. As shown in figure 7-3, the inputs of the vehicle dynamics model are wind speed, grade and tractive forces produced from rear and front tyres.

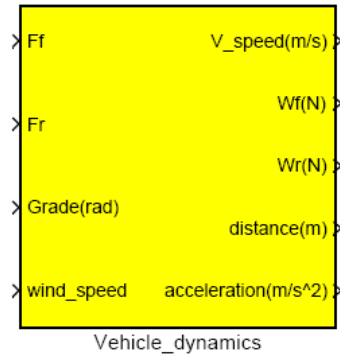

Figure 7-3 Vehicle dynamics block in Matlab/Simulink

The model is divided into two important parts as shown in figure 7-4. First are the dynamic equations in longitudinal direction including aerodynamic forces, rolling resistance and grade resistance. Second, the part which models the transient normal load transfer on the front and the rear axles of the vehicle. The normal loads on front and rear axles are inputs for the tyre model which will be explained next.

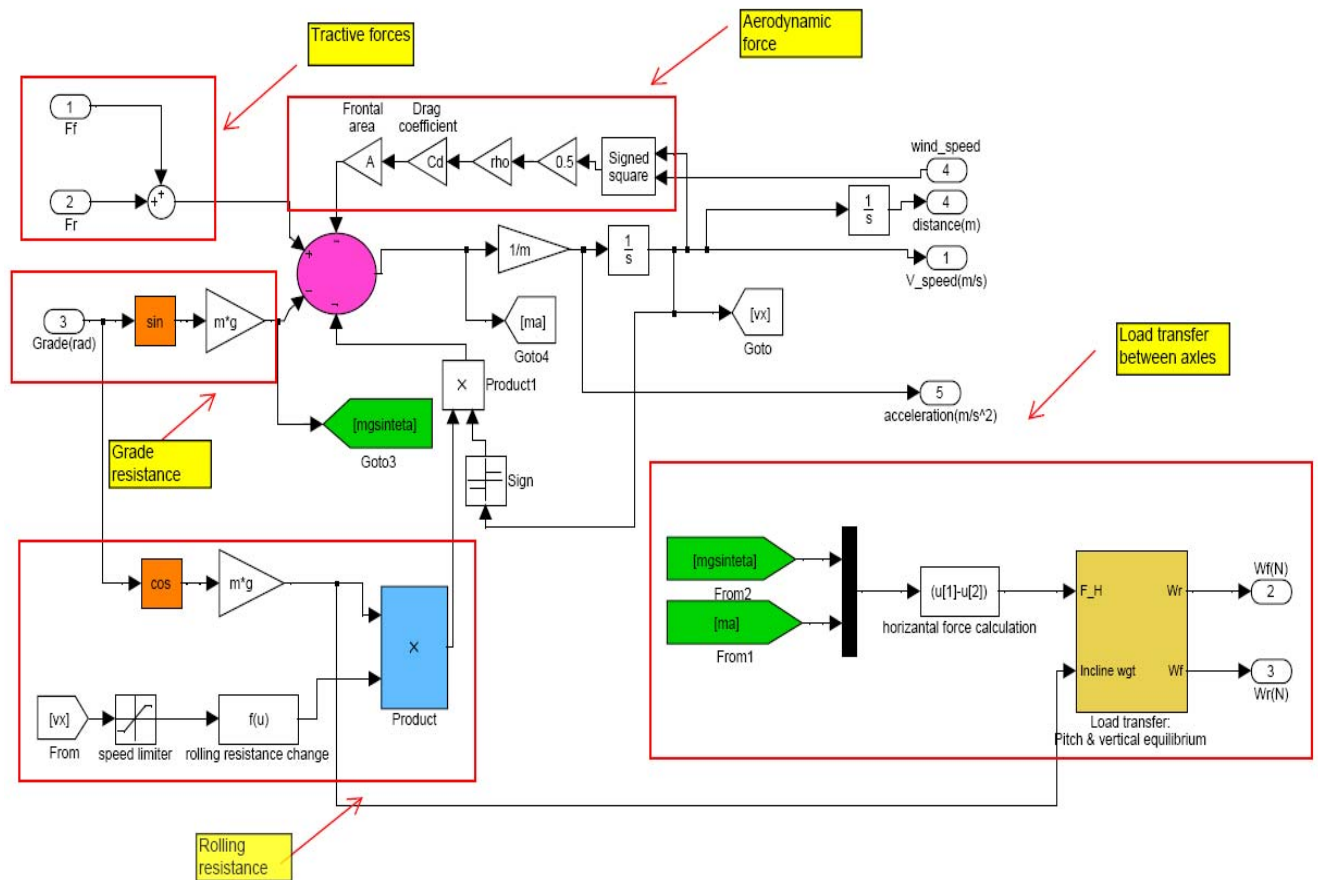

Figure 7-4 Vehicle dynamic block components

7.2.1 Tyre

In order to consider the effect of wheel slip, it is modeled in the tyre model. As shown in figure 7-5 the inputs for the tyre are the braking and driving torque from the driving axle with respect to the gear ratio, the normal load on wheel and the feedback from the longitudinal speed of the vehicle. The longitudinal speed of the vehicle is translated to rotational speed considering the wheel radius and it is compared with the speed of the wheel to find the wheel slip. Once the slip is found according to (4-11), the tractive force applied to ground is calculated based on the wheel slip and normal load on the wheel.

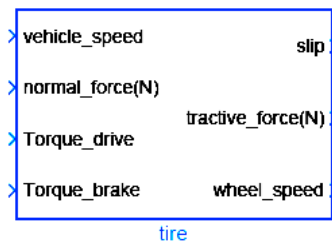

Figure 7-5 Tyre block in Matlab/Simulink

7.3 Engine

As described in Chapter 5 the engine is modeled purely statically using the efficiency map. A set of data in terms of torque and speed of the engine and the corresponded efficiency and specific fuel consumption in each operating point obtained from the engine of a series hybrid bus made by New Flyer Company is available [28]. Using interpolation and extrapolation the efficiency and specific fuel consumption in other operating points is found. The transient response of the engine is modeled by a low-pass filter having a 1.5 sec. time constant. The speed of the engine can not go higher and lower than a certain value according to the capability curve of the engine. So they are limited in the model.

7.4 Electric Motor

A permanent magnet synchronous motor is also modeled using look-up tables. Using look-up tables in any operation point the efficiency of the electric motor is interpolated. The efficiency map of the motor is obtained by using static equations of the machine [Appendix]. It should be noted that in order to find the input power of electric motor the average efficiencies of gear box and wheel axle and power electronics components is considered. In the model in order to match the operating point of the electric motor with the data available by look-up tables, field weakening must be considered. To apply the field weakening to the model, as the motor speed is increasing, in each simulation time step the product of torque and speed of the motor is compared with the maximum available power of the motor. Once the output power exceeds the maximum power, the motor power is kept constant and the torque is decreased inversely proportional to the speed. The speed and torque are limited according to the capability of the machine.

7.5 Driving Cycles

A vehicle could be driven in different ways. It means that it depends on the driver how to drive the car in terms of acceleration, braking, and maximum speed. To simulate a specific vehicle and evaluate its performance, the way that the driver drives has a significant impact on the vehicles performance especially for fuel consumption and emissions. So in the simulation drive train, there should be different driving cycles. In figure 7-6, two cycles of a CBD(city bus driving) used in the simulation are shown.

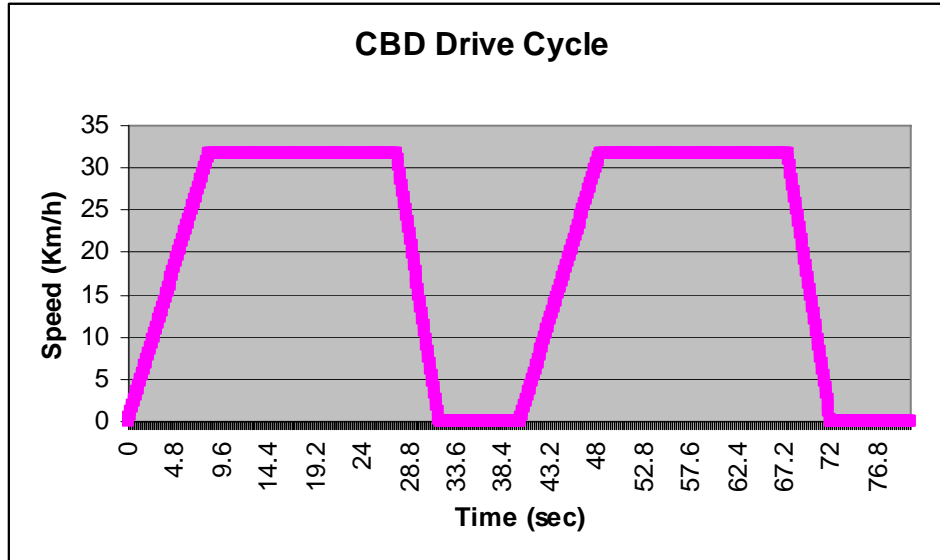

Figure 7-6 City Bus Drive cycle (CBD)

The driving cycles are modeled using look-up tables and are considered as inputs for the simulation instead of manual pushing of brake and throttle pedal.

7.6 Automatic Driver

To simulate the behavior of a driver following up a certain drive cycle, a model is required to calculate the required wheel torque. This model is called automatic driver. It consists of a PI controller having the reference driving cycle, actual speed of the vehicle and grade as inputs. Its output is the reference wheel torque to trace the drive cycle. In order to increase the functionality of the PI controller a feed forward loop is used. This loop based on the reference speed and grade, calculates the traction torque needed for tracing the reference drive cycle. The error between the reference speed and the actual speed is compensated by adding another torque calculated by the PI controller. In order to prevent integrator windup, the integrator is reset each time the speed falls down to zero. The block diagram is shown in figure 7-7.

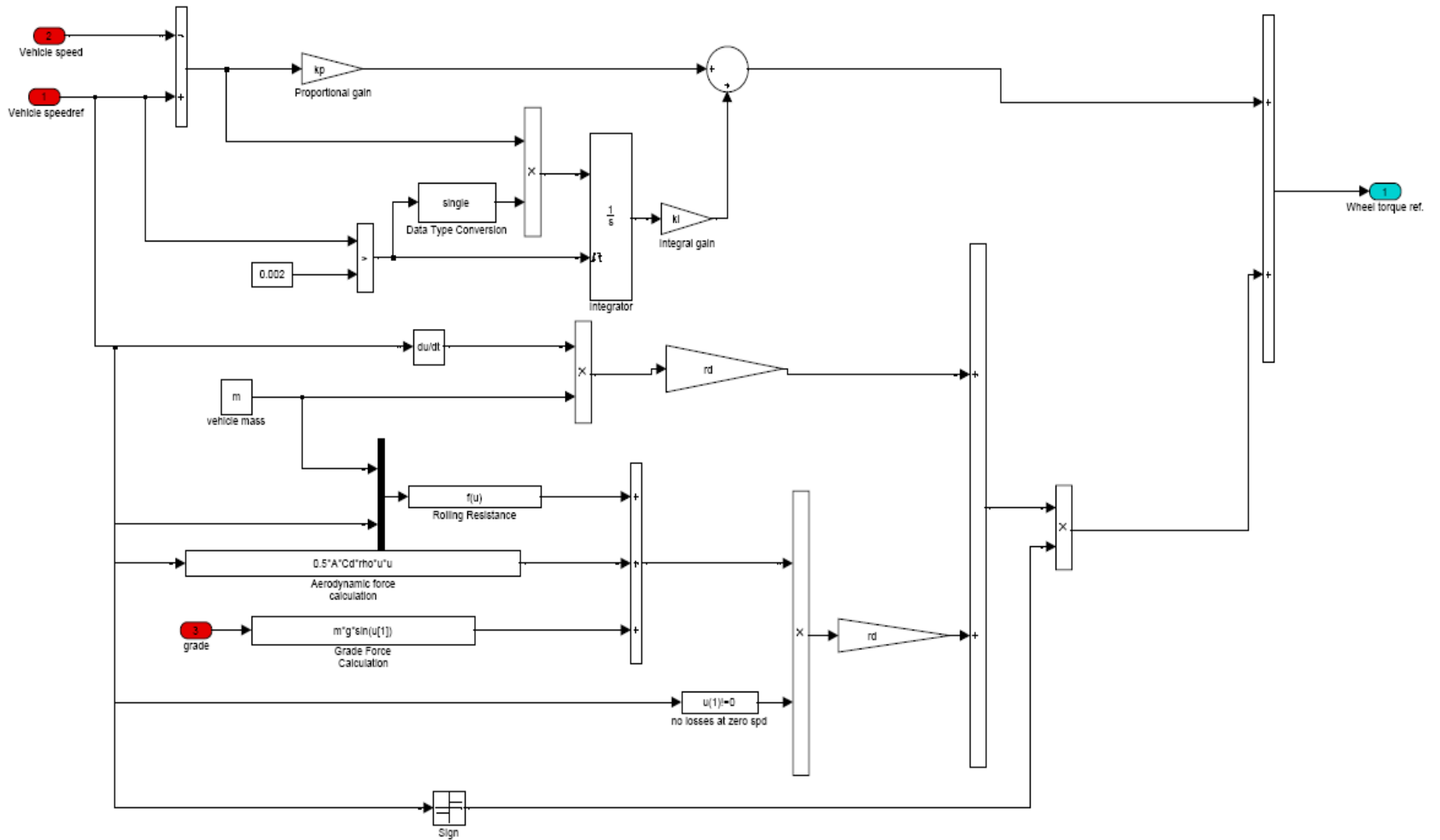

Figure 7-7 Automatic driver model block in Matlab/Simulink

7.7 Control and energy Management

The control and energy management system is made based on a series hybrid drive train which means that the engine is responsible to provide the power needed for traction and charging the battery system. The control system based on the needed power for traction and charging of the battery calculates the power that must be produced by the engine. This power as a reference must be produced by the engine. As long as there is a need for power to be produced by the engine, the control system sets the speed of the engine to a constant value and based on the needed power and the engine constraints, the corresponding engine reference torque is calculated. The reference torque for the electric motor is the reference torque calculated by the driver model.

Since in a series hybrid drive train, the engine and generator are coupled to each other, so they have the same speed. In order to keep the speed of the engine constant, a proportional controller is used to set the speed by changing the reference torque of the generator.

The other strategy to find the reference torque and speed for the engine is to find the torque-speed curve of engine to have the optimum efficiency. This curve is obtained from an efficiency map of the engine.

8 Simulation Results

In this chapter first the battery model is verified and secondly the drive train of a series hybrid bus is created based on the models previously explained. For simulation purposes the test data from a series hybrid bus produced by New Flyer Company located in Canada is used. The performance of the bus in terms of acceleration, fuel economy is studied.

8.1 Battery simulation results

In order to verify the battery model a 12 volt battery 46 A.h from Hawker Genesis was used. The fully charged battery was discharged with constant 6 ampere current in ambient temperature of 25°C. An electronic load (model: Power Tek EL12-110M) was used to discharge and charge the battery with constant current. For charging, the battery was charged with constant 30 ampere current. Once the terminal voltage reached to the maximum voltage given by the manufacturer [26], the voltage was kept constant until the battery was fully charged. Figures 8-1 and 8-2 show the results out of the simulation and tests. It is observed that the model has a good accuracy. The error during charging could be because of the coulomb efficiency which has not been considered in the model.

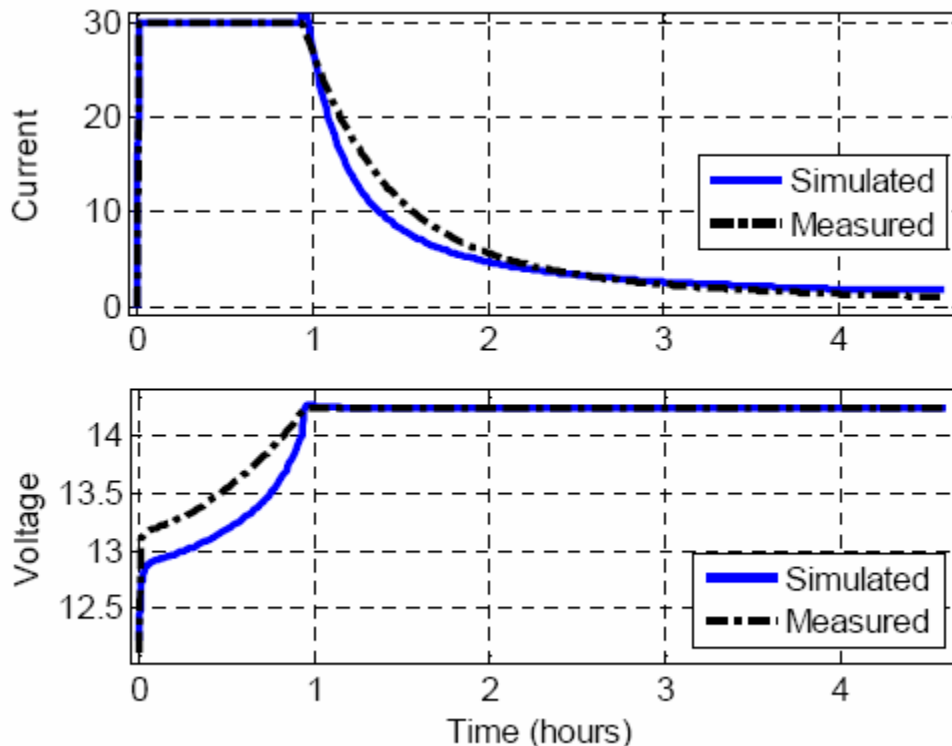

Figure 8-1 Battery charging test

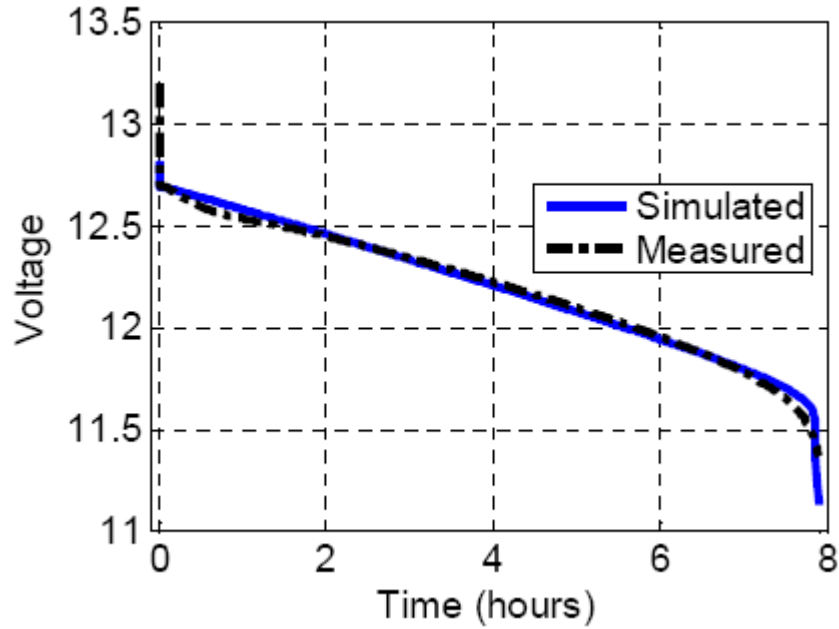

Figure 8-2 Battery discharging test

8.2 Series hybrid bus simulation

The specifications of the series hybrid bus are shown in table 8-1. As the test data available has been obtained from the CBD driving cycle so the CBD driving cycle was chosen as the reference drive cycle. The control strategy used to find the reference speed and torque of the ICE is to keep the speed of the ICE at 1600 rpm during power demand and 840 rpm when the ICE is idling. The ICE is also responsible to provide the traction power and keep the state of charge of the battery to 65%.

Table 8-1 Simulation data for series hybrid bus

Property	Value or Type
Fuel type	Diesel
Fuel heating value	38000 KJ/l
Peak engine power	150 kW
Peak engine speed	2500 rpm
Engine minimum speed	840 rpm
Engine maximum torque	895.4 N.m
Total vehicle mass	19500 kg
Wheel radius	0.47 m
Air resistance	0.65
Rolling resistance	0.012
Front area	7.4 m ²
Air_density	1.29 Kg/m ³
Maximum vehicle speed	32 km/h
Peak generator power	160 kW

Peak generator torque	1074 N.m
Peak generator speed	2500 rpm
Total gear ratio	16.1
motor power	140 kW
maximum motor torque	440 N.m
Maximum motor speed	950 rpm
Gearbox efficiency	1 s
Power electronics efficiency	18000
Generator-engine inertia	0.2
Gear efficiency	0.9
Battery type	Lithium-ion
Wheel inertia	27
Road type	Dry Tarmac
Power electronics efficiency	0.98

8.3 Acceleration performance

Acceleration performance of a vehicle such as a series hybrid bus studied in this thesis is normally quoted as the time taken in seconds to reach 105 Km/h from standstill. Figure 8-3 shows the acceleration of the bus studied from the simulation. As the bus is a rear wheel drive so the speed of the rear wheels are higher than the front wheels because of slip but in the case of the bus the slip is controlled and the driving torque applied to the wheels does not exceed maximum value. It is seen in figure 8-4 that during acceleration around the speed of 308 rad/sec. the traction motor gets to its maximum power and from that speed the out-put torque of the motor decreases inversely proportional to the speed.

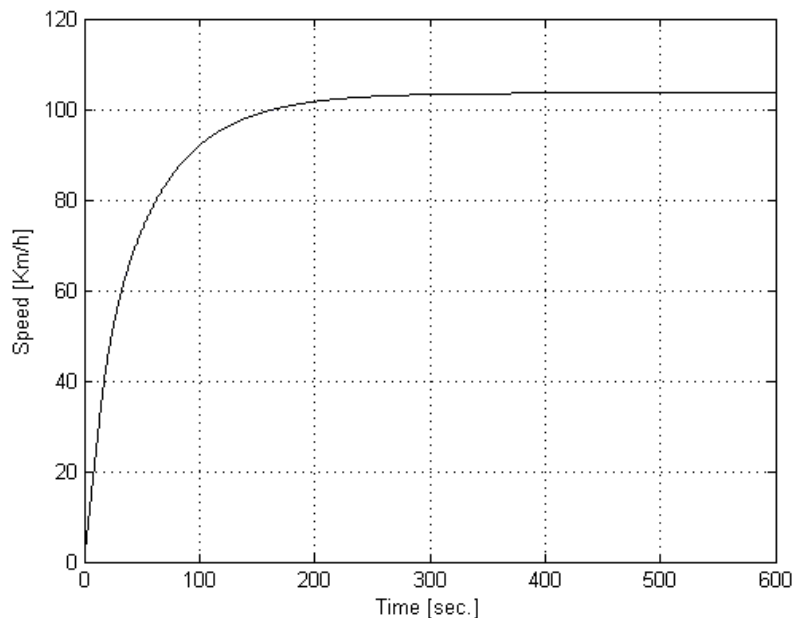

Figure 8-3 Acceleration test of bus

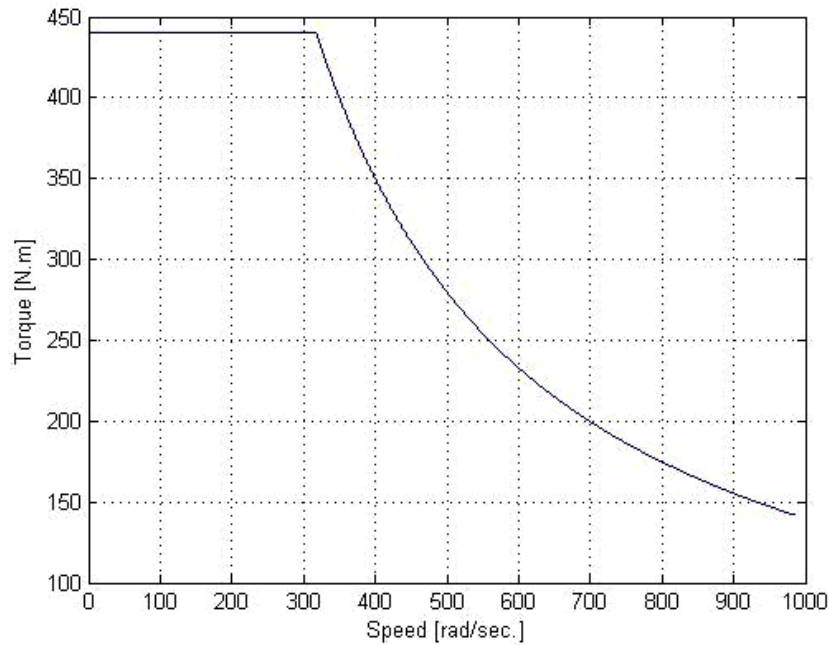

Figure 8-4 Wheel speed and translated actual vehicle speed

In order to see the effect of slip in the simulation, two cases are considered. It should be noted that this simulation test was done to see the effect of slip so in this test only the dynamics of the vehicle and the tire was simulated and the constraints regarding traction motor and engine was ignored so the speed results are not realistic. Firstly a drive torque of 7000 N.m is applied to the wheels and secondly the drive torque of 15000 N.m. It is clearly shown in figure 8-5 that the speed of the wheels is higher than the translatory speed of the vehicle (rotational speed rad/sec). As the wheel torque is increased the slip increases until it reaches to a value where the friction coefficient is maximum. A little bit increase in wheel torque leads to wheel spinning.

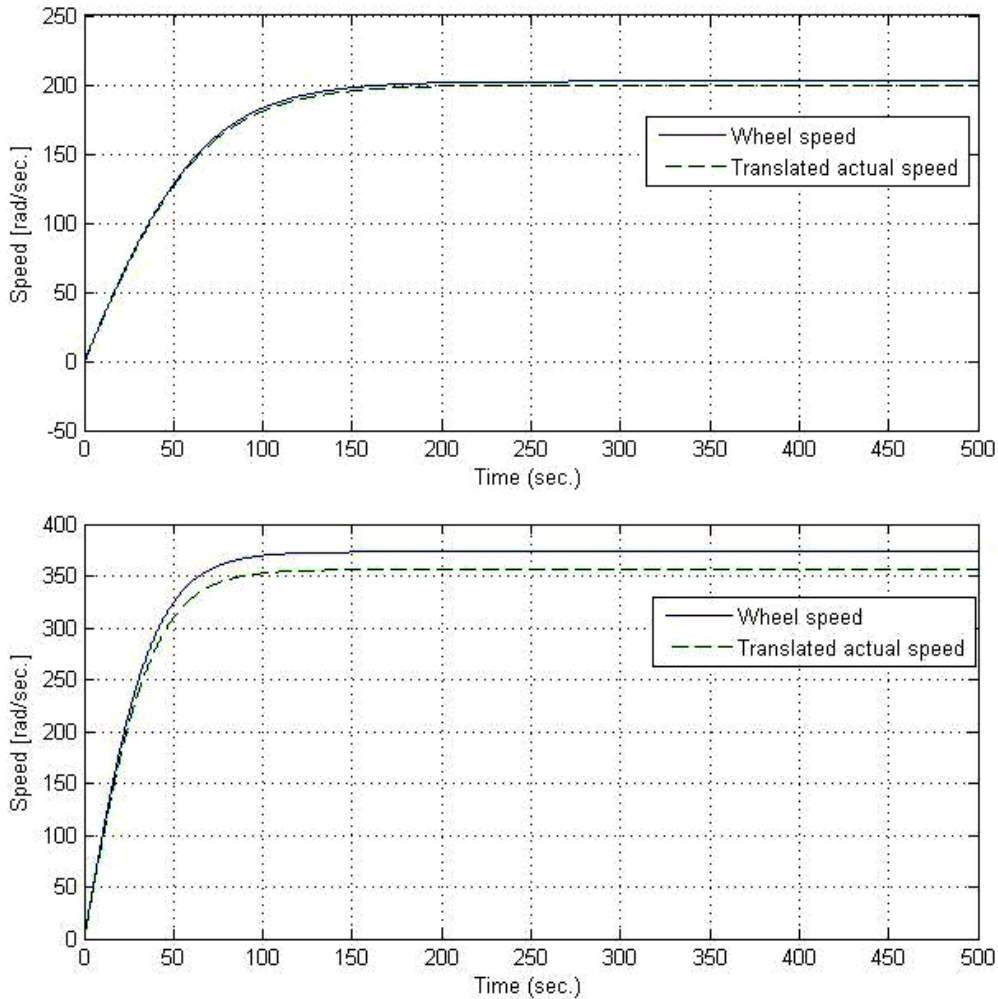

Figure 8-5 Wheel speed and translated actual vehicle speed

As it is shown in figure 8-5, once a higher drive torque is applied to the wheels, the difference in the speed of wheel and translated actual speed of the vehicles becomes higher.

8.4 CBD drive cycle test

Once all the parameters related to different components in the series hybrid bus are given as input to the simulation model. The performance of different drive train components including generator, traction motor, battery and engine is analyzed. In figure 8-6 the vehicle speed is shown.

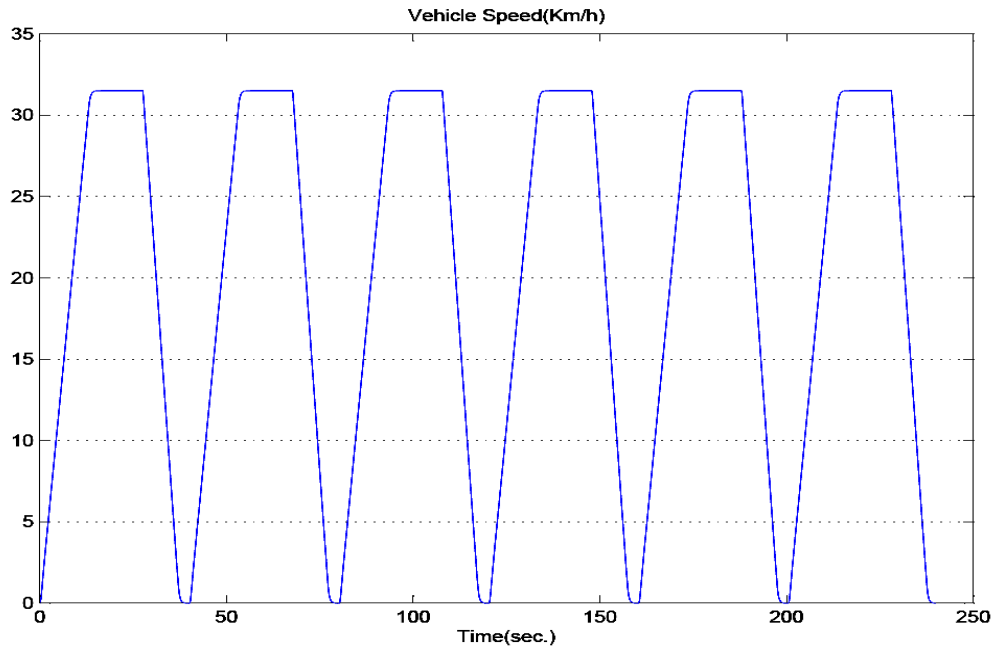

Figure 8-6 Bus speed

As the bus accelerates, the control system sets the speed of the engine to 1600 rpm and based on the demanded torque for traction and charging of the battery, the reference torque of the engine is calculated. It can be seen in figure 8-7 that the power of the engine is opposite to the power of the generator but a little bit higher because of efficiencies of the gear box and power electronic converters.

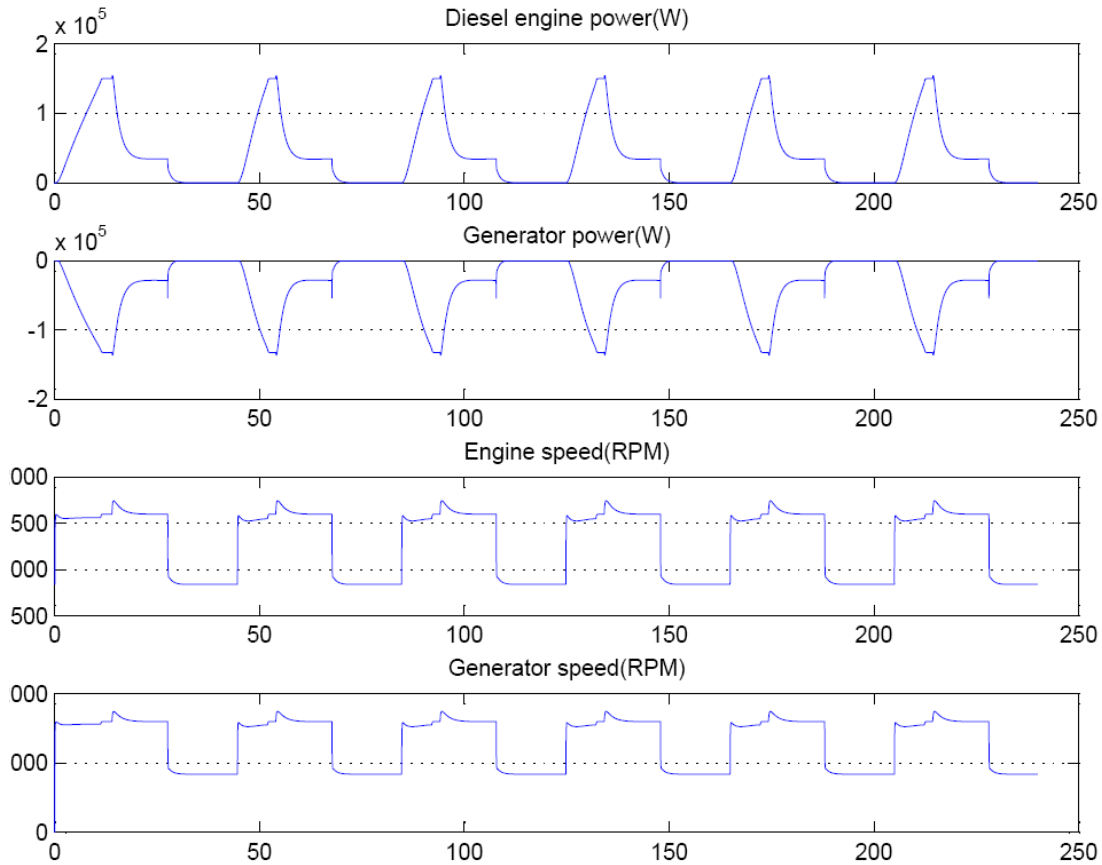

Figure 8-7 Engine and generator power and speed curve

Figure 8-7 also shows the speed and torque characteristic of the engine and generator. As can be seen, the speed of the engine jumps between 840 rpm and 1600 rpm. When there is a power demand the engine speed is set to 1600 RPM and the reference torque according to the demanded power and engine constraints is calculated. The jumps in the speed of the engine and generator are because of the dynamics of the generator–engine set which has been modeled by a first order system considering the inertia of the generator-engine set.

Figure 8-8 shows the performance of electric traction motor. Once the vehicle accelerates the torque of the motor is maximum as the speed reaches the maximum speed. In the cycle the acceleration is zero so the motor power suddenly decreases because it does not have to overcome the inertia of the vehicle and accelerate the total weight of it. It can also be seen that during the deceleration the power is negative which indicates that energy is being fed back to the motor to charge the batteries. The traction power and efficiency includes the efficiencies of gear box and power electronics.

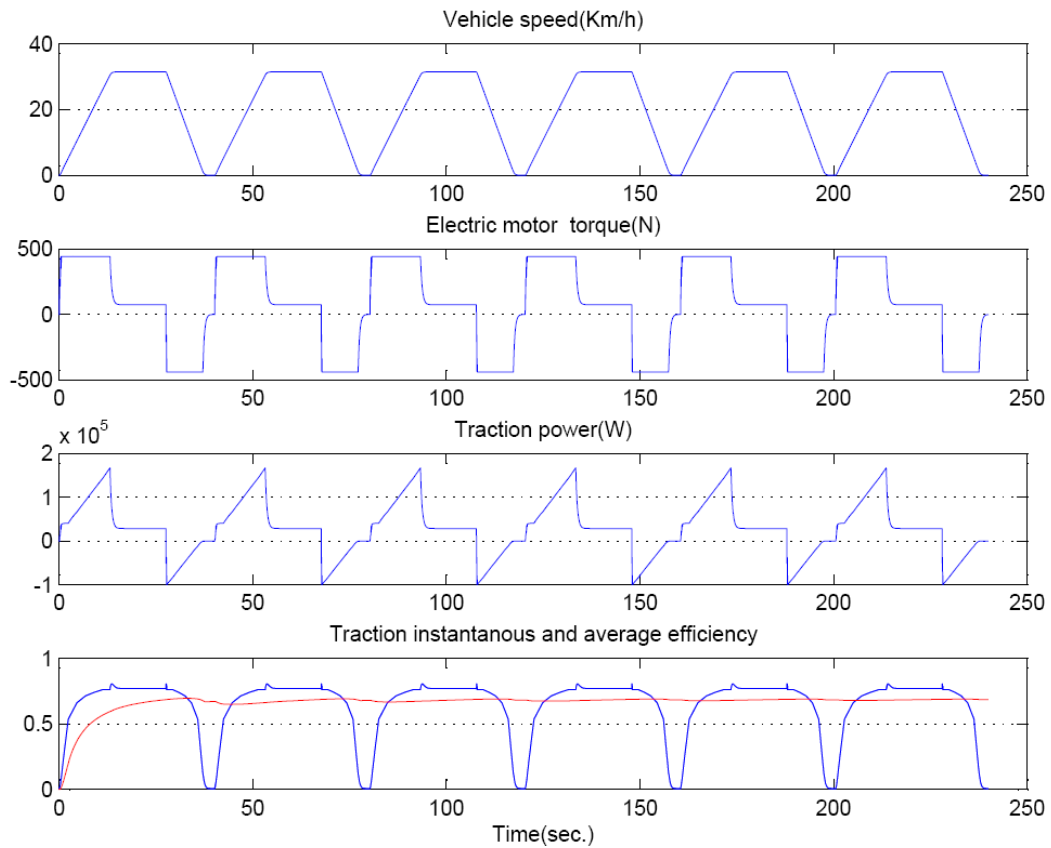

Figure 8-8 Electric motor torque, speed and efficiency

Figure 8-9 shows the engine power, generator power, traction power and state of charge of the battery. As the traction power exceeds the maximum engine power the rest of the needed power comes from the battery so the state of charge of the battery decreases. It is seen that during the deceleration the battery is charged and state of charge of it goes up. It is also observed that the energy management strategy used in control system tries to set the state of charge of the battery to 65 percent.

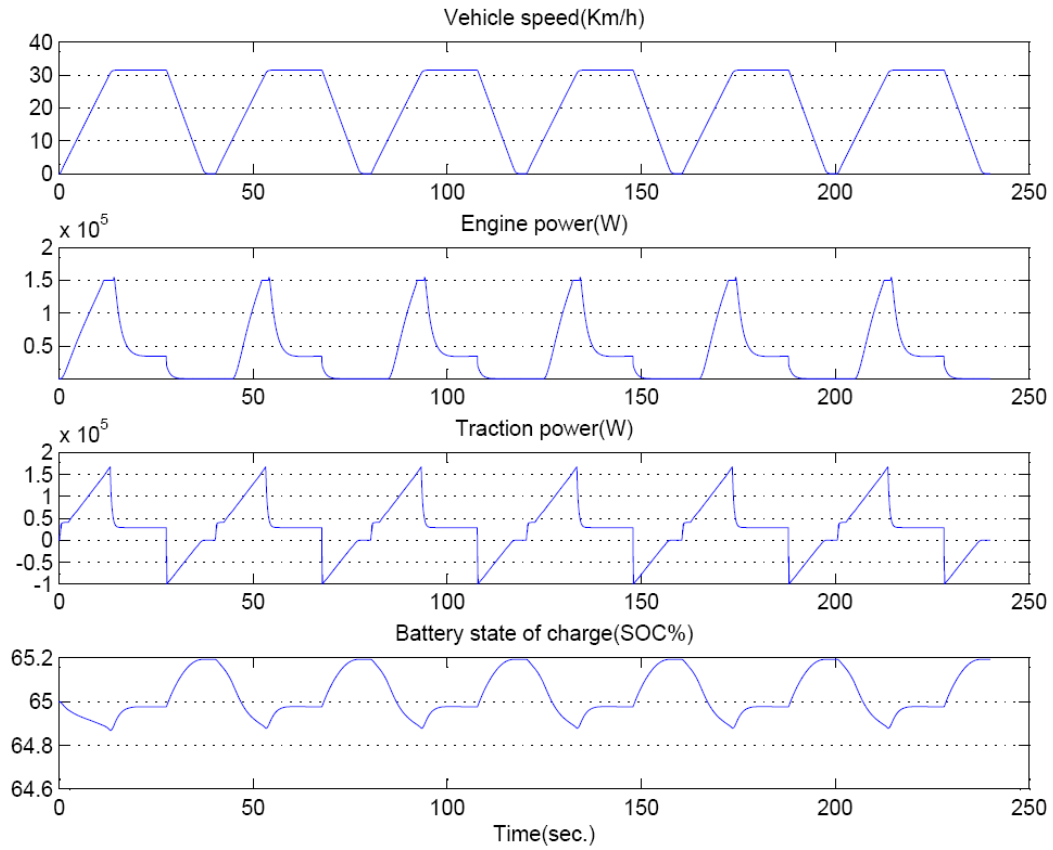

Figure 8-9 Battery state of charge change

In order to find the fuel economy, the efficiency of the engine in different operating points in terms of torque and speed is very important. The fuel power, average efficiency of the engine and fuel consumption results from the simulation are shown in figure 8-10.

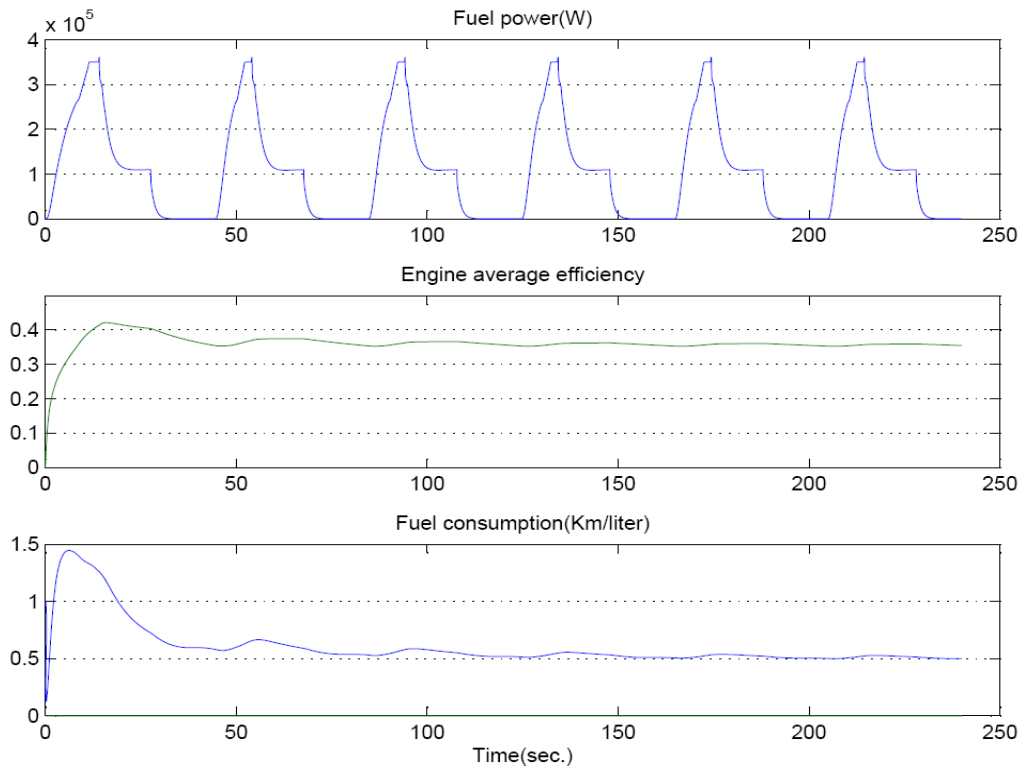

Figure 8-10 Fuel power, fuel consumption and average engine efficiency

The fuel economy of the bus was compared by the value obtained from the test data provided by New Flyer Company on CBD drive cycle. The results are shown in table

Table 8-2 Simulation and test result for fuel economy

Bus Model	Measured CBD fuel economy (Km/Liter)	Simulated CBD fuel economy(Km/Liter)	Error %
D40LF	1.91	2.04	-6.8

Since in the drive train some components like power electronics and gear box were not modeled and efficiency of them was considered constant to 98% and 90% respectively. So it would add some errors to the whole system. To find the efficiency map of the electric motor and generator the static equations were only used and the transient behavior of the motor was neglected. That would also introduce some errors to the system as well.

9 Conclusion

Regarding the significant role of modeling and simulation in the design process of hybrid vehicles the principles of simulation and some modeling methods were introduced. Different hybrid configurations and the drive train components including engine, electric motor, vehicle dynamics, and batteries were explained. In order to create a series hybrid bus, different components in the series drive train including vehicle dynamics, battery, engine, electric machine, automatic driver, tyre and energy management and control system were modeled.

1. Different models used for battery modeling were discussed. A nonlinear model for a lithium-ion battery was given. In spite of simple models used for batteries in hybrid vehicles simulations, a kind of nonlinear model was made, in which the model parameters change with the state of charge of the battery, temperature and discharge rate. The parameters of the battery were obtained from some tests done at HVDC research Company. The model is developed in Simulink/Matlab.

2. The dynamics of the vehicle were discussed and based on these dynamics a model in Simulink/Matlab was developed. The parameters of the vehicle dynamics model were collected from a series hybrid bus test data provided by New Flyer Company. The simulation result obtained from the model was validated by the test data of the bus for fuel economy.

3. The effect of wheel slip and dependence of tractive force on the road type was modeled by tyre modeling. It was shown that there is a slip between the wheel speed and the vehicle speed.

4. Using efficiency maps, the engine, electric motor and generator in the drive train were modeled.

Finally a series hybrid drive train was made in Simulink/ Matlab. Based on the parameters of a series bus from New Flyer Company the results of the simulation were compared with the test data. It was observed that the control strategy plays an important role in the fuel economy of the vehicle. Comparing the results of fuel economy and fuel consumption obtained from simulation and test data showed that by using more accurate models for engine, gear box, power electronics, the benefits of a good simulation model will become more and more dominant.

9.1 Future Work

To have more information about details of different components in the drive train, it is recommended:

1. To use dynamic models for electric machines and power electronics. In this case, the transient behavior of the machine is more observed. Having access to electric parameters

of the machine like current, voltage helps a lot to size components during the design process.

2. Other energy storage systems like capacitors and ultra capacitors must be modeled and effects of them in the drive train must be observed and analyzed.

3. Since most of the vehicle simulations are tested under different drive cycles and the battery is continuously charged and discharged the effect of cycling on the battery life must be considered during modeling. It would be beneficent if the model considers life cycling as well.

Finally, it should be noted that by creating more component models in the library of simulation environment, different batteries, engines for instance, testing different drive train configurations will become available and consequently getting to an optimum design becomes more achievable.

References

- [1] Shuo Tian, Guijun Cao, Qiang Han, Jiangiu Li, Mingguo Yang, "Modeling and Decoupling Control of ICE APU with Uncontrolled Rectifier in Series Hybrid Vehicle", Vehicle and power propulsion conference, p.p 1-6, Sept. 2006
- [2] Pugsley. G., Chillet, C., Fonseca, A., Bui-Van, A. L., "New Modeling Methodology for Induction Machine Efficiency mapping for Hybrid Vehicles", Electric Machines and Drives Conference, 2003. IEMDC03. IEEE International, vol.2, p.p. 776-781, Jun. 2003
- [3] Shangmunathan, U., Govarathan, R., Muthumailvaganan, Imayakumar A., "Modeling and Dynamic Simulation of IC engine Driven Permanent Magnet Generator Using Matlab/Simulink for Hybrid Tracked Vehicle", IEEE Conference on Electric and Hybrid Vehicles, p.p. 1-6, 2006
- [4] Cherefiles, A.R., Filizadeh, S., "Modeling and Transient Simulation of an All-Electric Terrain Vehicle(ATV), Canadian Conference on Electrical and Computer Engineering, p.p. 401-404, 2007
- [5] Northcott, D.R., Filizadeh, S., "Electromagnetic Transient Simulation of Hybrid Electric Vehicles", IEEE International Symposium on Industrial Electronics, p.p.833-838, June 2007
- [6] Filizadeh S., Cheverfiles A.R., Northcott D.R., "Analysis and Design of Vehicular Power Systems Using PSCAD/EMTDC", IEEE Vehicle, Power and Propulsion Conference, 2007
- [7] S.Williamson S., Emadi A., Rajashekara, "Comprehensive Efficiency Modeling of Electric Traction Motor Drives for Hybrid Electric Vehicle Propulsion Applications", IEEE Transactions on Vehicular Technology, Vol.56, No.4, p.p. 1561-1572, July 2007
- [8] Gao, D.W.; Mi, C.; Emadi, A., "Modeling and Simulation of Electric Hybrid Vehicles", Proceedings of the IEEE, Vol.95, issue 4, p.p. 729-745, April 2007
- [9] Onoda, S.; Emadi, A., "PSIM-based Modeling of Automotive Power Systems: Conventional, Electric, and Hybrid Electric Vehicles", IEEE Transactions on Vehicular Technology, Vol.53, Issue 2, p.p. 390-400, March 2004
- [10] J.Y. Wong, "Theory of Ground Vehicles", Third edition, United States of America, John Wiley & Sons. Inc., 2001
- [11] Ehsani M., Yimin Gao, Sebastien E. Gay, Emadi A., "Modern Electric, Hybrid Electric, and Fuel Cell Vehicles Fundamentals, Theory, and Design", United States of America, CRC Pres LLC, 2005
- [12] Ming Qian, "Sliding Mode Controller Design for ABS System", Master Thesis, Poly Technic Institute and State University
- [13] Michael Short, Michael J. Pont, Qiang Huang, "Simulation of Vehicle Longitudinal Dynamics", ESL Technical Report ESL 04/01, University of Leicester, 2004

- [14] Jalil, N.; Kheir, N.A. ;Salman, M. ,”A Rule -Based energy management Strategy for a Series Hybrid Vehicle”, Proceeding of American Control Conference, Vol.1, p.p. 689-693, June 1997
- [15] Amrhein Macro; Philip T. Krein, “Dynamic Simulation for Analysis of Hybrid Electric Vehicle Systems and Subsystem Interactions, Including Power Electronics”, IEEE Transactions on Vehicular Technology, Vol.54, No.3, p.p. 825-836, May 2005
- [16] Marcos, J.; Laga A.; Penalver, C.m.;Doval, J. ; Nogueira, A. ;Castro, C. ;Chamadoira, J., “An Approach to Real Behavior Modeling for Traction Lead-acid Batteries”, Power electronics Specialists Conference,2001 , IEEE 32nd Annual , Vol.2, p.p. 620-624
- [17] Dur Mathias; Cruden Andrew; Sinclair Gair; J.R. McDonald, “Dynamic Model of a Lead-acid Battery for Use in a Domestic Fuel Cell System”, Journal of Power Sources, Vol.161, Issue 2, , p.p. 1400-1411,Oct. 2006
- [18] Salameh, Z.M.; Casacca, M.A.;Lynch, W.A, “A Mathematical Model for Lead-acid Batteries”, IEEE Transactions on Energy Conversion, Vol.7, Issue:1, p.p. 93-98, March 1992
- [19] Zhan, C.J.; Wu, X.G.; Kromlidis, S.; Ramachandaramurthy, V.K.; Barnes, M.; Jenkins, N.;Ruddell, A.J., “Two Electrical Models of The Lead-acid Battery Used in a Dynamic Voltage Restorer”, Generation, Transmission and Distribution, IEE Proceedings, Vol.150, Issue:2, p.p. 175-182, March 2003
- [20] Lijun Gao; Shengyi Liu; Dougal, R.A., “Dynamic Lithium-ion Battery Model for System Simulation”, IEEE Transactions on Components and Pachaging Technologies, Vol.25, Issue: 3, p.p. 495-505, Sep. 2002
- [21] Dennis Doerffel; Soleiman Abu Sharkh, “A Critical Review of Using the Peukert equation for Determining the Remaining Capacity of Lead-acid and Lithium-ion Batteries”, Journal of Power Systems, Vol.155, Issue: 2, p.p. 395-400, April 2006
- [22] Bumby, J.R. ; P.H. Clarke; L. Forster,”Computer Modeling of Automotive Energy Requirements for Internal Combustion Engine and Battery Electric Powered Vehicle”, IEE Proceedings, Vol.132, No.5, p.p. 265-279, Sep. 1985
- [23] Moore s. ;Ehsani M., “An Empirically based Electrosorce Horizon Lead-acid Battery Model”, SAE Transactions, Vol.105, n^o6, p.p. 421-424, 1996
- [24] S.A. Nasar and LE “Unnewehr, Electromechanics and Electric Machines”, Second Ed., United States of America, John Wiley & Sons. Inc., 1993
- [25] Appebaum, J.; Weiss R., “Estimation of Battery Charge in Photovoltaic Systems”, 16th IEEE Photovoltaic Specialists Conference, p.p. 513-518, 1982
- [26] Genesis Application Manual, Fifth Edition, Hawker Energy Products Inc., 1999
- [27] S.Williamson S.; Rimmelapudi C.; Emadi A., “Electrical Modeling of Renewable Energy Sources and Energy Storage Devices”, Journal of Power Electronics, Vol.4, No.2, April 2004
- [28] New Flyer Co., “Fuel Economy Summary Sheet”, Bus number: 0611, June. 2006