

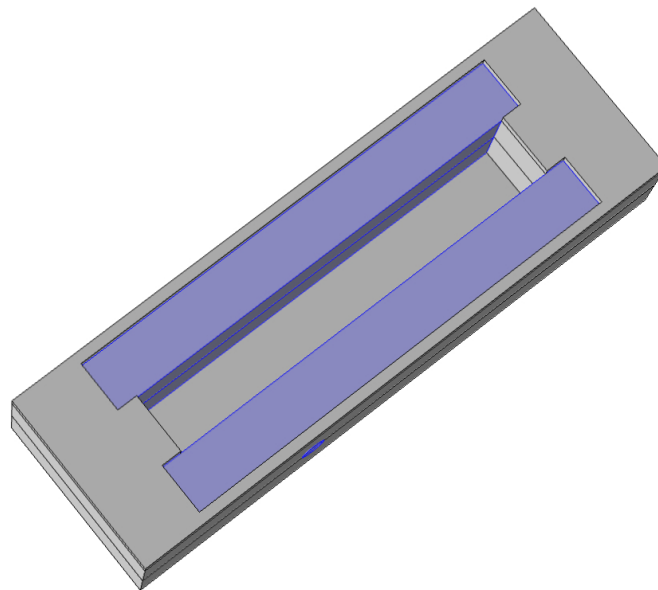

**CHALMERS**  
UNIVERSITY OF TECHNOLOGY

---



# **Theoretical design of a chamber for food treatment by pulsating electric fields produced by 10 kW generator.**

Chalmers University of Technology  
Master's Thesis Report

Johanna Fredriksson  
Rogers Sengoga Gatete



MASTER OF SCIENCE THESIS

**Theoretical design of a chamber for food  
treatment by pulsating electric fields produced by  
10 kW generator.**

Johanna Fredriksson  
Rogers Sengoga Gatete



**CHALMERS**  
UNIVERSITY OF TECHNOLOGY

Department of Electrical engineering  
*Division of Electric Power Engineering*  
CHALMERS UNIVERSITY OF TECHNOLOGY  
Gothenburg, Sweden 2018

© Johanna Fredriksson  
Rogers Sengoga Gatete, 2018.

Supervisor: Sven Isaksson  
RISE Research Institutes of Sweden  
RISE Bioscience and Materials - Agrifood and Bioscience  
Examiner: Yuriy Serdyuk  
Professor, Department of Electrical Engineering  
Chalmers University of Technology

Master's Thesis  
Department of Electrical Engineering  
Division of Electric power Engineering  
Chalmers University of Technology  
SE-412 96 Gothenburg  
Telephone +46 (0)31-772 10 00

Gothenburg, Sweden 2018

Master Thesis Report  
Johanna Fredriksson  
Rogers Sengoga Rogers  
Department of Electrical Engineering  
Chalmers University of Technology

## Abstract

The project has been conducted together with RISE Bioscience and Materials – Agrifood and Bioscience. At RISE a future European project is planned to use the pulsed electric field (PEF) method to perform research on the technology itself as well as to research on the specific test object press cake from carrot. The aim of the future project is to examine the PEF technology and to evaluate if usable contents can be extracted from the press cake with the help of PEF. In a growing world the food demand increases and the PEF method could be a solution to accomplish higher yields in food processing.

The aim of the work that has resulted in this report was to theoretically design a PEF test chamber. The goal was to evaluate an optimal design of the test chamber as well as to leave directions on how to use the chamber in a practical set-up.

The project has been conducted through literature studies of former experiments and treatment set-ups using the PEF method. During the project three different designs have been simulated and evaluated with COMSOL to achieve a homogeneous electric field inside of the full treatment volume.

With help of the simulations it has been concluded that a design with rectangular electrodes, where the edges of the electrodes are inserted inside the insulation, is the most optimal design to use for PEF treatment. With this model 96 % of the treatment volume is being treated with the applied electric field. A design with rounded electrodes also gives a treatment volume where 96 % of the volume is being treated homogeneously with the applied electric field. The rounded electrodes also gives the advantage of lower enhanced field at the end of the electrodes. This design however requires longer electrodes, hence a larger chamber leading to a less effective volume usage. The rounded electrodes also leaves it more difficult to construct. This gives the advantage to the rectangular electrodes.

Only directions of how the shape of the pulse could be optimized are presented in the report. The optimal pulse to be applied to the chamber varies depending on the properties of the tissue and cannot be described as only one optimal solution.

The report also includes a section about the safety aspects of how to use the chamber. An interlock has been suggested to ensure that the chamber can only be operated when a box enclosing the test chamber is closed.

Keywords: Pulsed electric field, PEF, Food Treatment, Pulse Generator, Irreversible Electroporation, COMSOL, Homogeneous electric field, Press cake.



## Acknowledgements

We would like first to thank our supervisor Mr. Sven Isaksson and the entire team at RISE Research Institutes of Sweden for the support, guidance, and time they invested in this work.

Finally, our sincere appreciation goes to the examiner Yuriy Serdyuk, whose office was always open for us whenever we had a question regarding the work. We are very grateful for the technical support and your efforts to keep us in the right direction. This work would not have been possible without your guidance.

Thank you.

Johanna Fredriksson  
Rogers Sengoga Gatete  
Gothenburg, June 2018





# Table of contents

<b>List of Figures</b>	<b>xiii</b>
<b>List of Tables</b>	<b>xv</b>
<b>1 Introduction</b>	<b>1</b>
1.1 Background . . . . .	1
1.2 Aim . . . . .	2
1.3 Problem description and tasks . . . . .	2
1.4 Scope . . . . .	3
1.5 Sustainability . . . . .	3
1.6 Ethics . . . . .	4
<b>2 Theory</b>	<b>7</b>
2.1 Processing of vegetable and fruit in food industry . . . . .	7
2.1.1 Pulsed electric field as pre-treatment for food processing . . . . .	7
2.1.2 Electroporation - the mechanism to permeabilize tissue by PEF . . . . .	8
2.1.2.1 Reversible and Irreversible electroporation . . . . .	9
2.1.3 Solid-liquid extraction . . . . .	10
2.2 Influence of PEF process parameters . . . . .	10
2.2.1 Electric field . . . . .	11
2.2.2 Treatment time $\tau_s$ . . . . .	11
2.2.3 Pulse shape . . . . .	12
2.2.4 Repetitive Pulse Application (Pulse frequency) . . . . .	14
2.2.5 Resistance of the load . . . . .	15
2.2.6 Capacitance of the load . . . . .	15
2.3 Total applied energy on tissue . . . . .	15
2.4 Ohmic heating comparable with PEF . . . . .	16
2.5 The Efficiency of PEF treatment . . . . .	17
2.5.1 Damage degree(P) . . . . .	17
2.5.1.1 Damage degree(P) with diffusion coefficient . . . . .	18
2.5.1.2 Damage degree(P) with disintegration index (Z) . . . . .	18
2.5.2 Energy efficiency . . . . .	18
2.6 Test object: Carrot . . . . .	20
2.6.1 Electrical properties . . . . .	20
2.7 Local electric field, breakdown in air bubbles . . . . .	21

2.8	Treatment Chamber . . . . .	21
2.8.1	Configuration of electrodes and geometry . . . . .	23
2.8.1.1	Parallel plate configuration . . . . .	23
2.8.1.2	Coaxial plate configuration . . . . .	23
2.8.1.3	Disk shaped and Round shaped electrodes . . . . .	24
2.8.2	Fringe effect . . . . .	24
2.9	Safety aspects of high voltage test equipment . . . . .	25
2.9.1	Safety box . . . . .	26
<b>3</b>	<b>Methods and set up</b>	<b>29</b>
3.1	Set up in COMSOL . . . . .	29
3.1.1	Boundary conditions . . . . .	29
3.1.2	Governing equations . . . . .	29
3.1.3	Materials . . . . .	30
3.2	Specifications of the pulse generator . . . . .	30
<b>4</b>	<b>Design of the batch chamber</b>	<b>31</b>
4.1	Geometry and size of the chamber . . . . .	31
4.2	Materials of the Chamber . . . . .	32
4.3	Design of test chambers . . . . .	33
4.4	Design of electrodes . . . . .	35
4.4.1	Electrode Thickness . . . . .	35
4.4.2	Electrode shape . . . . .	36
4.5	Insulation . . . . .	37
4.6	Enhancement of electric field . . . . .	39
4.7	Comparison of the three designs . . . . .	40
4.8	Running experiment without lid on the chamber . . . . .	41
4.9	Final dimension . . . . .	42
<b>5</b>	<b>Pulse characteristics</b>	<b>45</b>
<b>6</b>	<b>Practical design</b>	<b>47</b>
6.1	Coupling of the set-up . . . . .	47
6.2	Safety box . . . . .	48
6.2.1	Size and geometry of the box . . . . .	48
6.2.2	Choice of materials for the safety box . . . . .	49
6.2.3	Cables through the wall . . . . .	49
<b>7</b>	<b>Discussion</b>	<b>51</b>
7.1	Design of chamber . . . . .	51
7.2	Pulse settings . . . . .	52
7.3	Uncertainty of conductivity . . . . .	53
7.4	Test chamber for other materials . . . . .	53
7.5	Limitations . . . . .	53
7.6	Improvements and Future Work . . . . .	54
<b>8</b>	<b>Conclusion</b>	<b>55</b>





# List of Figures

2.1	Exponential pulse [20]	12
2.2	Pseudosquare pulse [20]	13
2.3	Unipolar (monopolar) pulse compared to Bipolar pulse on $Fe^{2+}$ concentration [22]	14
2.4	Principle of ohmic heating	17
2.5	Definition of effective pulse width ( $t_e$ ) and pulse width( $t_p$ ) of a signal	19
2.6	Simple representation of coaxial treatment chamber [48]	24
2.7	Heterogeneous distribution of the electric field due to fringe effect	25
4.1	Chamber design option 1	33
4.2	Chamber design option 2	34
4.3	Chamber design option 3	34
4.4	Effect of electrode thickness on the electric field distribution	35
4.5	Reference points for the lowest, A, and highest, B, field in the chamber	36
4.6	Rounded electrode chamber in 2D view	37
4.7	Parametric sweep of the radius "a"	37
4.8	Position of the spacer from 2D View	38
4.9	Spacer optimization for design 2	39
4.10	Spacer optimization for design 3	39
4.11	Comparison between the required electric field and enhanced field.	40
4.12	Comparison of all three designs	41
4.13	Electric field at the boundaries of the chamber without lid	42
4.14	Chamber design option 2	43
4.15	3D view of Electric field inside treatment zone.	44
6.1	Circuit of the interlock	47
6.2	Set up of selected system with generator, safety box and test chamber	48



# List of Tables

2.1	Electrical field dependent on cell size and structure . . . . .	11
2.2	Levels of specific energy applied to different tissues . . . . .	16
2.3	Different properties of carrot . . . . .	21
3.1	Boundary condition . . . . .	29
3.2	Simulation Parameters . . . . .	30
3.3	Limitations of generator output . . . . .	30
3.4	Limitations in settings that the protection will prevent . . . . .	30
4.1	Comparison of the three designs . . . . .	41
4.2	Dimensions for Design 2 . . . . .	43
5.1	Examples of how to achieve the same total energy with different settings	46
6.1	Dimension of chamber and safety box . . . . .	48
6.2	Properties for materials under consideration for safety box [59] . . . . .	49





# 1

## Introduction

In this chapter the aim of the project is presented as well as the problem description. This thesis has been conducted in collaboration with RISE, Research Institutes of Sweden. RISE conducts research in different fields including food preservation and extraction technology.

### 1.1 Background

Food processing is an important industry to improve food and to extract as many viable constituents as possible from its side-streams. The food processing is important to be able to use the grown food as effectively as possible. There are several methods for food pre-treatment and food processing. The methods vary from simple mechanical pressing or chopping, to more advanced techniques where electricity plays an important part of the treatment.

There are various applications for electrical energy in the food industry, especially in processing and preservation. The most common ones are ohmic heating, microwave heating, high-voltage arc discharge, low electric field stimulation and high-intensity pulsed electric field (PEF) application. Ohmic heating is one example of a thermal treatment method. However, all kinds of thermal treatments have drawbacks due to thermal damage to the food products which affects the taste, flavor, and nutrient contents of the food.

With an increasing demand of foods with a high nutritional value and fresh-like characteristics researchers have strived to develop non-thermal food treatment techniques as alternatives to the conventional thermal treatments [1], [2]. Pulsed electric field (PEF) technology is one of the non-thermal treatment methods that have attracted considerable attention due to its advantages over thermal methods. One of the major reasons why PEF is considered as a better alternative over conventional thermal methods is because of the small increase in temperature during processing which is especially important for sensitive food matrices such as for vegetables and fruits. In addition to this advantage, PEF is also preferred because of less electrical energy consumption compared to thermal methods [3].

For PEF treatment of food and drugs to be effective it is important to be able to control the pulse width, electric field amplitude, number of pulses as well as other parameters of the pulse and the treatment. During the last decades important re-

search have developed solid-state pulsed-power modulators which enables the control of these factors. Thanks to the modulators, PEF treatment can now exceed traditional methods for food processes [4].

As a future project at RISE an European project is to be conducted with the goal to examine the PEF method, more specifically PEF treatment on carrot press cake. The future project is to examine the effects of PEF treatment as well as research on what substances and nutrients that can be extracted from the press cake after treatment with PEF.

The goal of this present project is to provide RISE with required background material and a proposed theoretical design of the test chamber, so that subsequently a piece of the test equipment needed for the PEF treatments can be constructed and assembled. In other words, to design the PEF treatment chamber and the set-up of the equipment.

## 1.2 Aim

The aim of this thesis is to theoretically design a pulsed electric field batch treatment chamber based on the specifications of a 10kW pulse generator. The goal with the design is to achieve a homogeneous electric field to disintegrate cell structures to enhance extraction of solute substances from press cake of carrot inserted in water.

## 1.3 Problem description and tasks

The goal of the project was to examine and design a blueprint of a suitable batch treatment chamber for PEF treatment of press cake made from carrot, inserted in water. This implies evaluating different designs for a batch treatment chamber. It is important that the press cake is treated with homogeneous field throughout the chamber for equal treatment of the tissue, in order to make the research of the PEF treatment more accurate in the future project. Hence in the future project evaluating the treatment of the press cake, it is of high importance to know what level of percentage of the test object that is being treated with the expected electric field.

In the project the characteristics of the pulses to be applied have been examined theoretically through literature study to find a suitable voltage level and electrical field, as well as other pulse parameters to treat the carrot inserted in water with the right energy to open the cell structures without damaging the tissue.

The work also includes consideration and design of safety equipment. The work can be separated into smaller sub-tasks:

1. Literature study to determine the dielectric properties of the test object, and how these properties relate to pulse parameters (pulse width, number of pulses, amplitude and treatment time).

2. Simulation of a parallel plate geometry using COMSOL to achieve uniform distribution of the electric field by comparing different design set-ups.
3. Determine the optimal size and the capacity of the chamber, considering the required voltage and electrical field as well as the limitations of the pulse generator and the requirements from RISE.
4. Design of safety equipment to enhance the safety when using the PEF equipment.

The project was as mentioned conducted with and for RISE, whereas RISE had several requirements on the design. The requirements from RISE can be seen below:

1. Volume of treatment zone: 3 dl
2. Distance between electrodes: 3 cm
3. Depth of chamber: 5-10 cm
4. Length of chamber: 10-20 cm
5. At least 95 % of the treatment volume should be treated with the set electric field
6. The design of the chamber should be easy to design and clean
7. The chamber should be cheap in terms of material choice
8. A safety box should be constructed to enclose the chamber
9. An interlock should be connected to ensure closed lid during operation

## 1.4 Scope

In the project the high voltage generator supplied by RISE is considered as the pulse supply to the PEF chamber. The project is developed around the restrictions of the generator. The capacity of other generators has not been considered in the report.

A PEF treatment chamber can either be a static or a continuous type. The static type of PEF chamber is mainly designed to serve for laboratory scale studies and similar purposes, whereas continuous chambers are more common in industrial applications. In this project, only the static type of a chamber is considered, a so-called batch chamber.

Furthermore, the dielectric properties of the test object (press cake of carrot) have not been measured experimentally, instead a literature study has been used to determine the most important parameters of the test object. The conductivity of the carrot press-cake is of high importance for the resistance of the load. Without practical measurements on the test object the resistance of the load can not fully be examined.

## 1.5 Sustainability

PEF used as pre-treatment of food can be a solution to increase the sustainability of food production. Because of the increasing population there is also an increased

demand on food. Most of the land areas that could be used as cropland is already being exploit and deforestation for new cropland is not a sustainable solution for the environment and the planet [5] [6] [7]. Instead more efficiently grown and processed crops could be the focus to meet the higher demand.

This is where PEF comes in as a possible solution. PEF does not influence the way the crops are being grown, instead PEF can help to increase the efficiency when processing the crops. Crops are not only used for fresh food but also nutrients and other contents are being extracted and used in further food processes. With the help of PEF, a higher gain can be achieved when extracting the useful contents from the crops, this way PEF can help making the food processing more efficient and sustainable.

A trend around the world is the increasing interests of organic farming. With the organic way of growing crops, the plants might be smaller and the yield of the harvest might be lower in volume compared to commercially grown crops [8]. This way of growing could lead to the consequence that croplands are not being used in the most optimal way. To enhance the output of these organic croplands PEF could be an important factor to add more value to the organic farming.

The method of PEF is more energy efficient than other treatments used in food processes, such as, mechanical, enzymatic, and heating or freezing/thawing [9]. Not only does PEF treatment result in higher gain of the extraction, the treatment itself requires less energy. The PEF treatment can therefore be seen as a sustainable treatment compared to the commonly used treatments.

## 1.6 Ethics

When working with products that are to be consumed by humans, for example medicine and food, it is critical to investigate the product and evaluate the safeness of the product and how it will interact with the human body. When using the PEF method for treatment of food the cell structure is affected. How does the treatment affect the healthiness of the food? It might be possible that the damaged cell structures interact with the human body differently than how an untreated substance normally does. The treated food product might be unhealthy or in worse case even harmful to be consumed. Before using the treated substances in food products, it is important that this is thoroughly investigated.

The effect of treated food products might be accumulated and could possibly lead to greater damage in the future, consequences that cannot yet be seen until the products have been used for several years. With unhealthy food products future consequences might include increasing risks for developing cancer or other diseases.

Even if the food might not be directly unhealthy to eat there is still an ethical point of view to discuss, which is to what extent it is ethical to treat food products. How much can the food products be treated or changed and still be called natural food?

If a fruit or vegetable is being treated with PEF, can it still be called natural? It is naturally grown but treated with electrical pulses to increase the gain. Can that be called a natural process?

The way people normally value food processes might have to change for the PEF treatment to be considered as a normal healthy way to treat the food. Even though the PEF treatment retain both the structure and the taste of the food products in a better way than heat treatment does, heat treatment might among the public society still be seen as a more careful and non-harmful way to treat the food compared to the PEF treatment. This might be because of the long-time experience with heat treated food.

Heat treatment was found to kill bacteria in 1863 when Louis Pasteur did his experiments [10]. Heat treatment of food also occurs at home in your own kitchen. Therefore, the heat treatment is not seen as a strange method. PEF treatment on the other hand has not been used in that extent earlier and could then be seen as alien and harmful among the public.

The last but still very important thing that needs to be considered for the PEF treatment is whether it affects the people working in the industry with the processing. Laboratory studies have found that exposure to EMF (Electromagnetic Field) affects the biological systems [11]. Therefore, the greatest caution must be taken to ensure that the level of electric field is within the safety levels so that no harm is caused to the people working with the PEF equipment.

For this specific project of designing the test equipment for research of PEF, the safety aspect for the researcher using the equipment is of high importance. In section 6.2 the specific safety design of the test object is presented. Even if the safety aspect is of importance, the safety cannot be guaranteed by the authors. It is important that the equipment is handled with care and that caution is taken for the high voltage applied to the chamber. It is also important that the chamber is only used as it was intended to be used.

During the thesis the guidelines and code of Ethics from The Institute of Electrical and Electronics Engineers (IEEE) have been considered and followed. Two points of the code of ethics have been specifically important to this project:

- *3. to be honest and realistic in stating claims or estimates based on available data*

In the report there is information about the increase in gain when using PEF compared to other methods. There is also information about the efficiency of PEF. This project does not include practical experiments or try-outs, this information is found from other articles. Because the information is not found through this project it cannot be assumed that the information can be directly applied to this project.

## 1. Introduction

---

- *9. to avoid injuring others, their property, reputation, or employment by false or malicious action*

As mentioned earlier in this chapter the equipment designed in this project requires high voltages. The safety of the users of the equipment is of high importance. The safety cannot be ensured, but to increase the safety the equipment should only be used as it is thought to be used, i.e. for PEF treatment, where the chamber is enclosed in the safety box.

# 2

## Theory

### 2.1 Processing of vegetable and fruit in food industry

Vegetables and fruits are important food products not only as unprocessed crops but also in many different processed states. The processed vegetables and fruits contain pigments and antioxidants used as ingredients in production of other processed food products. The Non-thermal treatment of food consists of mainly two set of techniques; mechanical treatment and mass transfer. Cutting, slicing and juice extraction are all examples of mechanical treatment. Mass transfer is the migration of substances between two different concentration gradients. The aim of mass transfer is to extract substances, remove water from food or to transfer a new substance into the food matrix.

In order to increase the efficiency of food treatment a so called permeabilization/disintegration of the tissue can be done. Permeabilization include mechanical, thermal, chemical or enzymatic methods. These pre-treatments simplify the mechanical processes and the mass transfer. As the pre-treatments might be quite severe to the plant tissue they could lead to negative effects of product losses or thermal degradation on the molecules. The pre-treatments also require high amounts of energy and prolong the time of the processing.

A method that can pre-treat plant tissue in a similar way without damaging the structure of the molecules or requiring high amounts of energy would be preferable. PEF treatment is a method that shows high potential to become the solution for this problem.

#### 2.1.1 Pulsed electric field as pre-treatment for food processing

PEF as a method to treat food was first discussed in the 1960s but is still a novel technology. Only a few applications have been up scaled from research to pilot or industrial sizes [12]. PEF as a technology to pre-treat plant foods has advantages compared to conventional permeabilization techniques as it is a fast and low-energy method that can permeabilize the food without changing the structure of the food, increasing the temperature, or cause thermal degradation [13].

PEF is the method of applying high voltage direct current pulses of short width to the product. Applying these short pulses between at least one electrode and one ground electrode will cause a potential difference leading to a pulsed electric field working on the product. The width of the pulses can range from microseconds to milliseconds and the high voltage pulses can be in the range of 0-50 kV. The applied voltage will then cause an electric field of the strength between 0.1 - 50 kV/cm depending on the applied voltage and the distance between the electrodes [13]. The PEF treatment can be designed either for batch treatment or for treatment of a continuously flowing product where the product flows into the chamber where it is being treated by the pulsed electric field and then flows out of the chamber. A batch chamber is a static chamber that can only treat one batch at a time.

### **2.1.2 Electroporation - the mechanism to permeabilize tissue by PEF**

The aim of PEF treatment is the same as for the conventional pre-treatments, to permeabilize the plant tissue to increase the efficiency of the food processing. The method to permeabilize the product by electric field is called electroporation. The mechanisms that causes the plant tissue to permeabilize is not yet fully understood. There exist several different theories to explain the mechanism, for example electrocompression, the electrocompression associated with phase transition, the electrohydrodynamic instability, and the wave instability [14].

The most commonly used theory is called electroporation. The theory of electroporation include the mechanism of the creation of pores at the cell membrane that increases the conductivity over the membrane. The theory of electroporation describes the course of electroporation in the following way; Applied electrical pulses with a pulse width from the microsecond to the millisecond range are applied to the plant tissue. If the length of the pulses are long enough, depending on the cell properties, a trans-membrane potential will build up over the cell. For efficient electroporation the voltage over the cell is typically between 200 mV-1V. The cell membrane is typically 5 nm deep and the electric field of  $10^8 V/m$ . The energy needed for electroporation is low, therefore it is more efficient to use pulses, instead of continuously applied voltage, to decrease energy usage.

The applied voltage will cause the membrane to charge up because of an increased ion flow. This will lead to a localized change in the membrane structure which will cause the creation of pores. The pores are filled with water molecules and are called aqueous/hydrophilic pores. The aqueous pores will then increase the conductivity over the cell membrane with several orders of magnitude, increasing the possibility of transporting substances over the membrane. With a high enough voltage such that sufficient number of pores will be created along the membrane the mass transfer will increase as the cytoplasm is transported out of the cell. The rate of the charging of the cell membrane depends on the size of the cell. Sensitive cells are charged faster and the breakdown of cells occurs locally, step by step, cell by cell



in the plant tissue [15], [16]. Not all cells open up by one pulse, therefore several pulses could be required to open up all cells in the plant tissue [16].

The project is based on literature studies of commonly used electrical properties and therefore the most commonly used electropermeabilization theory is accounted for in this project. For further reading of other theories earlier listed, see [14].

Using PEF as pre-treatment have several advantages compared to the commercial methods for permeabilization. The extraction of substances from the cell will improve with a higher yield as well as a higher rate of the extraction as a result. Because of the improvement in yield from the pre-treatment, extraction parameters can be lowered, such as temperature levels and the concentration of the solvent used to extract substances. As mentioned earlier PEF can also help reducing the energy used in the process [13].

### **2.1.2.1 Reversible and Irreversible electroporation**

The mechanism of electroporation can lead to two final outcomes. The two possible states are reversible electroporation and irreversible electroporation. The states describe whether or not the cell membrane is able to repair itself and return to its initial state after the PEF treatment.

In the case of reversible electroporation, the cell is permeabilized by a low field close to the threshold value for initiation of pores. Pores are created at the cell membrane which leads to higher conductivity over the membrane. The cell is left in this state for a while even after the electric field has been removed but can then spontaneously go back to its initial state. The membrane closes, the conductivity goes back to the original value and the transmembrane potential is restored. Cell recovery is only possible if the right conditions are present for cell survival and if the applied electric field is kept low [17]. Reversible electroporation is wanted for applications where it is important that the cell is not damaged during treatment. Reversible electroporation is for example used in medical use to introduce cytotoxic drugs in cancer cells, this procedure is called electrochemotherapy.

Irreversible electroporation, also called membrane rupture, occurs when the electric field and energy are high enough to permanently damage the cell. The stable state of the cell is lost and the treatment might even result in breakdown of the plasma membrane [17]. Every cell type has a specific electric field threshold that will cause irreversible electroporation. The field strength needed depends on the size and geometry of the cell, as well as the chemical composition of the cell. With a typical cell size of 40-200  $\mu\text{m}$  for plant cells, an electric field strength of 1-2kV/cm is needed for irreversible electroporation. Irreversible electroporation is used in food processing to improve disintegration and to permeabilize the food tissue. Irreversible electroporation by PEF can be used to improve several food processes for example solid-liquid extraction, mechanical extraction of juices and oils, assisting cutting/slicing operations, dehydration, and improving freezing, to mention a few [13].

### 2.1.3 Solid-liquid extraction

The main focus of this project is the design of a chamber thought to be used for pre-treatment of solid-liquid extraction. Solid-liquid extraction is an industrial process that extracts substances from the tissue of vegetables and fruits where the substances are to be used as ingredients in food products. The solid-liquid extraction is also used in wine production.

The substances are migrated from a solid phase in the tissue to a liquid phase outside of the cell and the process is caused by a concentration gradient. Solid-liquid extraction is a process that could add value to by-products and waste from vegetables and fruits by increasing the amount of usable content from the tissues.

In industrial use a solvent is added to the tissue to enhance the extraction, but the solvent is not wanted in the final product and can in some cases even be toxic. This implies a need for the solvent to be separated from the extracted substances, the separation is both energy consuming and might not always be fully successful. Pre-treatments to soften the cell membrane and the structure of the tissue to increase the extraction yield and thereby reducing the use of solvent is usually done by mechanical, thermal or enzymatic treatments. As mentioned in section 2.1 these treatments damage the tissue and leads to product losses or thermal degradation on the molecules. The use of PEF as a pre-treatment to solid-liquid extraction is found to be very useful. The use of solvent can be decreased as well as the temperature and the processing time.

Research has found that with the use of PEF an increase of extraction yield for several molecules can be achieved, including molecules as poly-phenols, sucrose, carotenoids, betalains, and chlorophylls. These findings have been done for different plant tissues, for example apple, grape and carrot. Compared to the control, an increase in the yield by 39% has been reported for the molecule carotenoids, extracted from tomato peel by-product [13].

## 2.2 Influence of PEF process parameters

The effectiveness of PEF system to achieve irreversible permeabilization and enable easy extraction of salute substances from plant cells depends on the process parameters such as electric field strength, treatment time, specific energy, pulse shape, pulse width, and pulse frequency, to mention but a few. The intent of this theory section is to present the appropriate process parameters to enable irreversible electroporation for treatment on carrot press cake.

The electric field must satisfy some conditions; it should be relatively uniform in the treatment zone, high enough to disintegrate cell structures but also less than

what could cause breakdown and damage the food. Therefore to achieve the highest efficiency of PEF, it is very important during the design to consider appropriate voltage to apply, optimal distance between electrodes and the geometry of the electrode such that it enables uniform distribution of electric field within the treatment zone.

### 2.2.1 Electric field

For parallel plate electrodes, the relationship between applied voltage and electric field is given by equation 2.1,

$$E = \frac{U}{d} \quad (2.1)$$

where  $U$  is the applied voltage, and  $d$  is the distance between two electrodes.

Electric field is the main process parameter in the PEF treatment system that enables permeabilization. To reach irreversible electroporation (see chapter 2.1.2.1 for irreversible electroporation) a critical value of the electric field needs to work on the tissue. The critical electrical field both depends on the tissue itself but also on other parameters related to the pulse. In general, for plant cells of sizes of 40–200  $\mu m$  an electrical field of 1–2 kV/cm are needed for irreversible electroporation. While for microorganism, with a cell size of 1–10  $\mu m$ , an electrical field of 12–20 kV/cm is needed. For more values of electrical field depending on cell size and structure, see table 2.1. The value of the specific electric field also varies with the length of the pulses. One example is irreversible electroporation of *Chlorella vulgaris* cells. For a pulse with the length of ms, an electric field strength of 4 kV/cm was used, while for shorter pulses at  $\mu s$  an electrical field strength of 10 kV/cm was to be applied to achieve irreversible results [13], [18].

**Table 2.1:** Electrical field dependent on cell size and structure

Cell type	Cell size $\mu m$	Electric field kV/cm
Plant cell	40–200	1–2
Microorganism	1–10	12–20
Soft plant tissue (mesocarp, pericarp)		0.1-10
Hard material (seeds, stalks)		20

### 2.2.2 Treatment time $\tau_s$

The treatment time is given by the number of pulses multiplied by the pulse-width, see equation 2.2,

$$\tau_s = nt_p \quad (2.2)$$

where  $n$  is the number of pulses and  $t_p$  is the pulse-width. The treatment time is considered to be the second most important process parameter which dictates the PEF efficiency. Keeping the other parameters constant, several experiments indicate that an increased treatment time leads to a higher efficiency of PEF. This is true until a threshold value of the treatment time is reached where the efficiency cannot be further improved by a longer treatment time. To avoid increase of temperature in the tissue, the pulses should be kept relatively low, as the temperature increase linearly with the length of the pulse. See chapter 2.4 for more theory on heating caused by the current flowing through the tissue, ohmic heating.

### 2.2.3 Pulse shape

As irreversible permeabilization only occurs above a certain threshold value a square shape of the pulses compared to exponential pulses would optimize the energy consumption. The exponential pulse rises to the maximum value and then slowly decreases, leaving a large portion of the pulse having a value below the threshold value, see Figure 2.1. In comparison, the square wave keeps the top value for a longer time, and is therefore able to keep the voltage above the threshold value and irreversibly permeabilize the tissue with a larger part of the pulse, see Figure 2.2. During the time periods where the exponential pulse is below the threshold voltage, no pores are created. During these periods heat is generated in the tissue [19].

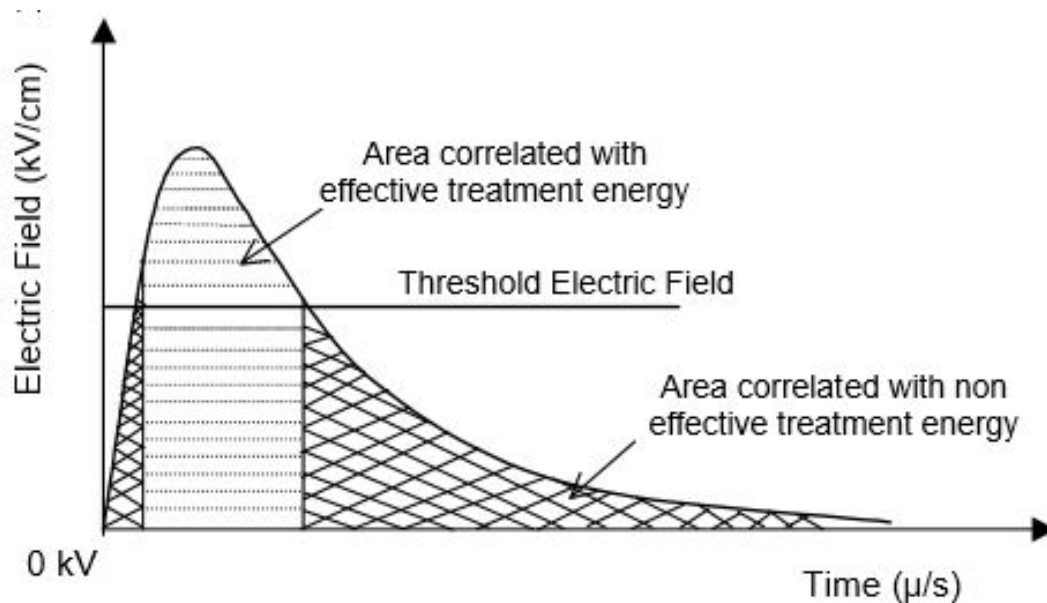
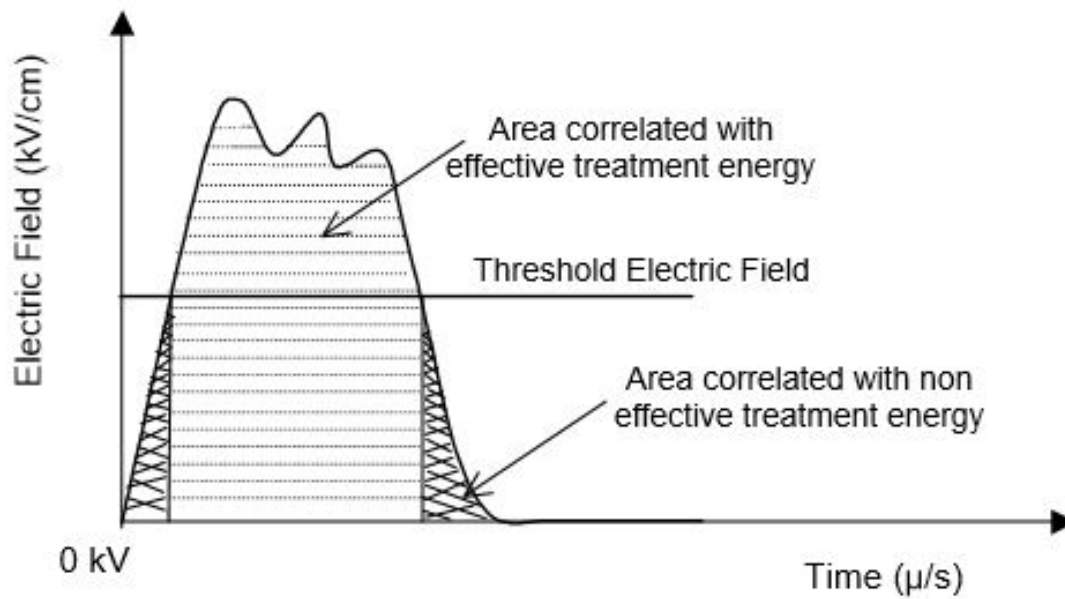

Figure 2.1: Exponential pulse [20]



**Figure 2.2:** Pseudosquare pulse [20]

The shape of the pulse can also be observed in terms of polarity, i.e. monopolar and bipolar pulses. Monopolar pulses are the pulses with a single polarity over time, whereas bipolar pulses are the pulses with alternating polarities. The monopolar waveform is most commonly used in different applications because the generators for monopolar pulses are cheaper to manufacture compared to bipolar generators.

Nevertheless, through different studies and experiments it has been shown that the bipolar waveform is preferred for monopolar pulses. Bipolar was found to be more efficient in increasing the yield compared to the monopolar under the same conditions [4].

Secondly, in addition to the yield increase, Figure 2.3 shows that a higher concentration of metal ions were released into the test material from the stainless steel electrodes (release of  $\text{Fe}^{2+}/\text{Fe}^{3+}$ ) when monopolar waveforms were applied compared to the bipolar.

Even though bipolar pulses are preferred, compared to monopolar pulses, due to its ability to increase the production and to minimize food contamination due to electrode erosion, the pulse generators able to produce bipolar pulses are more expensive to manufacture, and this remains a challenge for industries to invest in bipolar generators [21]–[23].

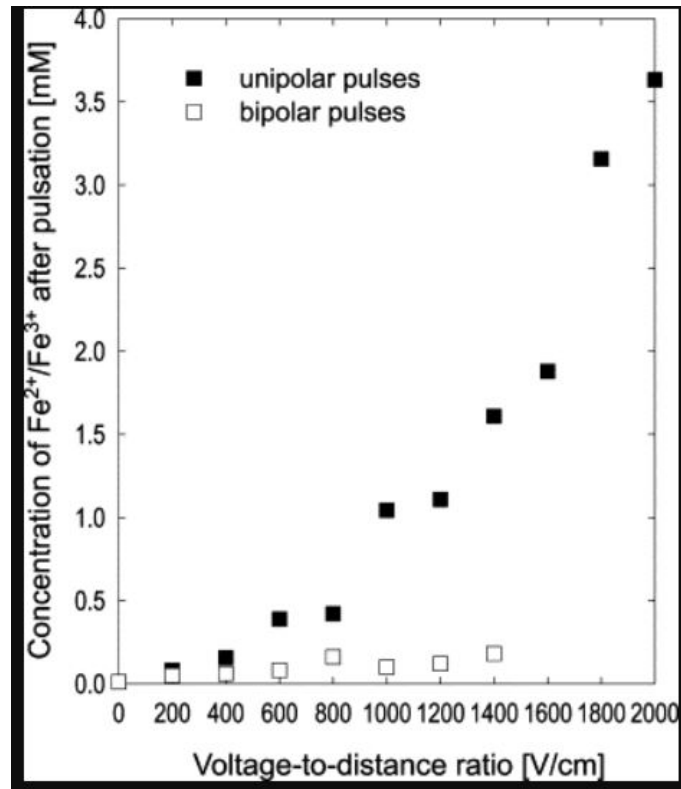

**Figure 2.3:** Unipolar (monopolar) pulse compared to Bipolar pulse on  $Fe^{2+}$  concentration [22]

### 2.2.4 Repetitive Pulse Application (Pulse frequency)

The intent of this part is to highlight the effects of high or low repetitive frequency to influence the efficiency of the PEF system.

The rate at which pulses are applied during the entire treatment time is known as repetitive frequency. Several studies have shown that not all cells of a tissue can be opened by a single pulse, Hence several pulses per unit time are applied to increase the effectiveness and efficiency of PEF [24].

Even though little is known about the effects of repetitive frequency for electroporation, it is believed that lower frequencies causes more cell damage than higher frequencies. This is because lower frequency gives longer time between each pulses. With a longer time between each pulse, the cells get ample of time for charging the cell membrane, Hence, facilitating pore formation and increasing the PEF-induced permeabilization [25].

The exact value of the frequency depends on the type of the tissue, for instance in one experiment conducted on onion tissue the lower frequency used was 1Hz whereas the higher frequency used was up to 50000Hz. The same study also indicated that beyond the highest frequency there was no change observed in the permeability of the cells [21]–[25].

### 2.2.5 Resistance of the load

The resistance of a conductor is described by

$$R = \frac{l}{\sigma A}, \quad (2.3)$$

where  $l$  is the length between the electrodes,  $\sigma$  is the conductivity of the conductor and  $A$  is the cross-section area of the conductor [26]. In the same way the resistance of the test chamber can be calculated by the same equation (2.3), where  $l$  is the distance between the electrodes,  $\sigma$  is the conductivity of the test object and  $A$  is the cross-section area of the electrodes. As can be seen in the equation, the conductivity of the test object and the dimensions of the test chamber are the parameters that define the resistance of the load.

### 2.2.6 Capacitance of the load

The capacitance of the chamber can be calculated as a parallel-plate capacitor, where the capacitance  $C$  is calculated as

$$C = \varepsilon_r \varepsilon_0 \frac{A}{d}, \quad (2.4)$$

where  $\varepsilon_r$  is the relative static permittivity,  $\varepsilon_0$  is the electric constant,  $A$  is the area of overlap for the two plates and  $d$  is the distance between the two plates [26].

## 2.3 Total applied energy on tissue

The total energy applied on the tissue after one full treatment is another way of describing the parameters of the applied pulse. This way of describing the pulse combines the electric field strength, the length of the pulse as well as the number of pulses applied to the tissue. The energy of one pulse  $W_p$  is calculated from

$$W_p = \int_0^{t_p} p(t) dt, \quad (2.5)$$

where  $p(t)$  is the instantaneous power and  $t_p$  is the length of the pulse. The instantaneous power  $p(t)$ , can be calculated by

$$p(t) = u(t)i(t), \quad (2.6)$$

where  $u(t)$  is the voltage applied over the electrodes and  $i(t)$  is the current flowing through the test object. Equation 2.6 can also be written as

$$p(t) = \frac{u(t)^2}{R}, \quad (2.7)$$

where  $R$  is the resistance of the test object. Inserting equation 2.7 in equation 2.5 gives the energy for one pulse described as

$$W_p = \int_0^{t_p} \frac{u(t)^2}{R} dt, \quad (2.8)$$

where  $t_p$  is the pulse length. The energy of one pulse can also be calculated from the capacitance of the chamber and the voltage applied to the chamber

$$W_p = \frac{1}{2}CV^2, \quad (2.9)$$

where  $W_p$  is the energy for one pulse, C is the capacitance and V is the applied voltage [26]. The total applied energy is then given by the energy of one pulse, times the number of pulses applied to the tissue as

$$W_T = nW_p, \quad (2.10)$$

where  $W_T$  is the total energy and n is the number of pulses applied [19].

The energy that is needed to be applied depends on the tissue and can vary, in the range from 0.5 kJ/kg - 90 kJ/kg. Table 2.2 presents the specific energy delivered for different tissues [24].

**Table 2.2:** Levels of specific energy applied to different tissues

Tissue	Energy kJ/kg
Apple	70
Beetroot	7
Rapeseed	42-84
Sugar beet	0.5-24

## 2.4 Ohmic heating comparable with PEF

Ohmic heating, also known as joule heating, is in itself an application used in food industry for different applications such as food preservation. Both Ohmic heating and PEF technologies have the same principle set-up, meaning the food materials are held between electrodes connected to the energy source, see Figure 2.4 for set-up.

Unlike PEF where irreversible electroporation is the goal (see section 2.1.2.1), in Ohmic heating electric energy is dissipated into food materials in form of heat. The principle of generating heat is based on the fact that when current flows through electrically conductive food materials, heat is generated due to resistive heating.

In section 2.1.2.1 it was stated that there is a certain critical value of electric field needed to achieved irreversible electroporation. If the threshold value of electric field is not reached electroporation will not be achieved, instead all the energy will be converted into heat due to ohmic heating.

For the exponential pulse, see Figure 2.1, when the signal is below the threshold value no electroporation will take place, instead heat will be generated. In the PEF system this heat is regarded as losses.

Some pulse shapes, such as exponential, that rises fast to its peak and decays slowly with a longer tail will generate heat hence increase losses, this is the reason to why



pulse shape is an important parameter in the PEF system. In such cases it is better to use pulses of shorter pulse width than longer ones not to have temperature rise within the chamber.

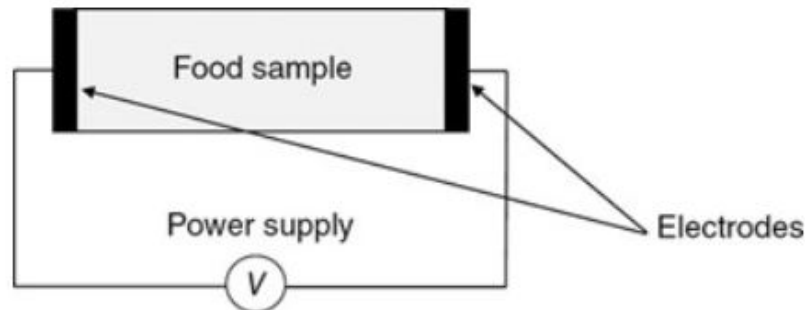

**Figure 2.4:** Principle of ohmic heating

The volumetric heat generation rate (specific heat power) is, given by

$$q = \sigma E^2, \quad (2.11)$$

where  $q$  is the specific heat power or heat power density in [Watts/cubic meter],  $\sigma$  and  $E$  are the electrical conductivity and electric field intensity respectively. The total specific volumetric energy is given by

$$W = q\tau_s, \quad (2.12)$$

where  $\tau_s$  is the treatment time, as defined by the equation 2.2. As seen in the equations 2.11 and 2.12 the generated heat increases with the square of the electric field,  $E$  and increases linearly with the length of the pulse. [9], [19], [27]–[30].

## 2.5 The Efficiency of PEF treatment

The overall efficiency of the PEF system is not only measured in terms of quantity of treated products but also in terms of energy consumption. Energy consumption is the ratio between useful energy used for treatment and the input electrical energy. Quantity of products shows the efficiency of PEF to destroy biological tissues and enable extraction of solute substances. The ability of the PEF treatment system to destroy biological tissues and enable extraction is called damage degree (P).

### 2.5.1 Damage degree(P)

The estimation of the damage degree P, which is defined as the ratio of the damaged cells to the total number of cells, can be estimated by measuring either the coefficient of diffusion or conductivity of the test materials.

### 2.5.1.1 Damage degree(P) with diffusion coefficient

Equation 2.13 below estimates the damage degree by using the diffusion coefficient measurements in the PEF-treated materials

$$P = \frac{D - D_i}{D_d - D_i}, \quad (2.13)$$

where  $D$  is the measured apparent diffusion coefficient and the subscript  $i$  and  $d$  are the values for intact cells and fully destroyed cells, respectively.

### 2.5.1.2 Damage degree(P) with disintegration index (Z)

In the same way of measuring the diffusion coefficient, the damage degree can be calculated for by measuring the conductivity of the treated object. The disintegration index is calculated as

$$Z = \frac{\sigma - \sigma_i}{\sigma_d - \sigma_i}, \quad (2.14)$$

where  $\sigma$  is the measured electrical conductivity value at low frequency (1–5 kHz), and the subscripts  $i$  and  $d$  are the conductivity of the untreated (initial) and completely disintegrated cells. Equation 2.14 gives  $Z=0$  for intact cells and  $Z=1$  for fully disintegrated cells. However, a problem with the disintegration index is to establish a relationship between damage degree and the calculated index. Currently the two terms are linked by the empirical Archie's equation according to;

$$Z = P^m, \quad (2.15)$$

where the value of  $m$  lies between 1.8 - 2.5 for biological tissues, such as carrots, potatoes and apple [9], [31].

## 2.5.2 Energy efficiency

In the PEF treatment system, the energy efficiency is defined as the ratio between useful energy and the input energy supplied by the generator. From the subsection 2.3 it was observed that the input electrical power per pulse is given by the equation 2.7. If an ideal pulse is assumed, the input power per pulse can be written as

$$P_{pp} = \frac{U^2}{R}, \quad (2.16)$$

where  $P_{pp}$  is the input power per pulse,  $U$  is applied voltage and  $R$  is the resistance of the treatment chamber. In the PEF system, the degree to which the input electrical energy is converted into useful energy is influenced by two main factors, the shape of the pulse and the geometry of the chamber. The geometry of the chamber enables a uniform distribution of electric field  $E_{th}$ . For every pulse applied in an enclosed volume,  $V_O$ , the volumetric heat generated within the treatment zone is given by the specific power multiplied by treatment volume. The specific power is calculated as

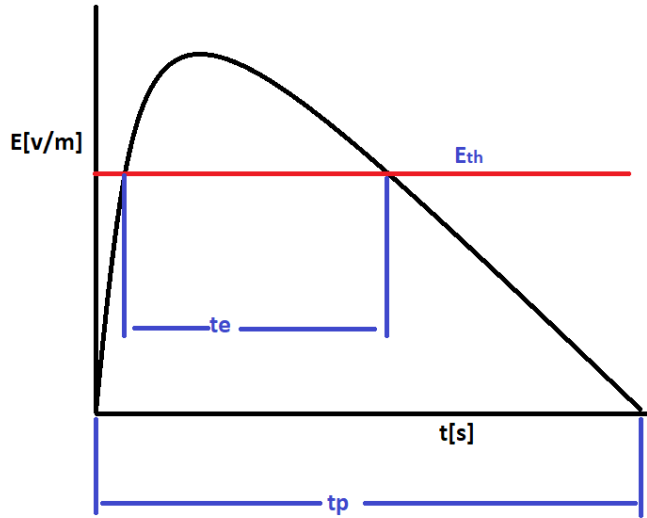

**Figure 2.5:** Definition of effective pulse width ( $t_e$ ) and pulse width( $t_p$ ) of a signal

$$P_v = \sigma_d E^2 V_o, \quad (2.17)$$

where  $\sigma_d$  is electrical conductivity of food materials (S/m) and  $E$  is electric field intensity(V/m).

In the previous sections, it was seen that for electroporation to take place, the electric field intensity need to be equal to or greater than the threshold value  $E_{th}$  ( $E \geq E_{th}$ ). The efficiency  $\eta$  is given by the ratio of dissipated Power within the treatment volume (see 2.17) to the power of an input signal (see equation 2.16).

$$\eta = \frac{E_{out}}{E_{in}} = \frac{R V_o \sigma E_{th}^2}{U^2}, \quad (2.18)$$

where,  $R$  is the Resisitive load of the chamber,  $V_o$  treatment volume,  $\sigma$  electric conductivity of the test material,  $E_{th}$  threshold electric field, and  $U$  is the applied voltage.

Equation 2.18 is however based on two significant assumptions.

1. The pulse width ( $t_p$ ) of the input signal is equal to the effective pulse width ( $t_e$ ) where the effective pulse width is the width of the signal that corresponds to the threshold value of electric field (i.e. an ideal square pulse).
2. The electric field intensity  $E_{th}$  is entirely homogeneous within the treatment zone.

In case of a pulse-width longer than the effective pulse width (for instance Figure 2.1) and if the threshold electric field intensity  $E_{th}$  is not uniform throughout the

chamber ( $V_o > V_{eff}$ ) the efficiency of the system will be different from 2.18 and can be expressed as

$$\eta = \frac{E_{out}}{E_{in}} = \frac{RV_{eff}\sigma E_{th}^2}{U^2} \times \frac{t_e}{t_p}, \quad (2.19)$$

where  $V_{eff}$  is the effective volume. The highest efficiency can be achieved only if,  $V_o = V_{eff}$  and  $t_p = t_e$ . For definition of some of the variables used in above equation refer to Figure 2.5. [20], [32].

## 2.6 Test object: Carrot

As described in the introduction, the batch chamber is to be used in an European project where the primary focus is to use the PEF treatment on carrot. In this chapter the electrical properties for carrot are presented. The electrical properties of the test object are important for the design of the test chamber, for it to match the pulse generator and to design an optimal set up.

### 2.6.1 Electrical properties

To be able to design the chamber based on the requirements, the electrical properties of carrot need to be known. The conductivity of carrot impacts the electrical set up of the system as the conductivity of carrot affects the resistance of the chamber. The electrical properties of carrot vary depending on the cell size, the moisture content of the carrot as well as the content of nutrients, ions and other substances. A good example of nutrients that affects the conductivity are the salts and acids which are ionic in nature hence acts as electrolytes.

As the press cake that is to be used in the future project was not available for measurements during this thesis, no practical measurements have been done to verify the values of the electrical properties. Instead several sources have been collected to create a list of the electrical properties. In table 2.3 information about the different properties of carrot is presented. As can be seen in table 2.3 the conductivity varies between a value of  $0.33 \text{ mS/cm}$  and  $2.3 \text{ mS/cm}$ , this indicates that the conductivity of carrot cannot be connected to a certain value. The conductivity varies, as mentioned, with moisture content as well as nutrient content. However, even though there are no measurements done for press cake, it could be expected that the conductivity would be lower compared to fresh carrot since the said contents which are ionic in nature are already removed during extraction of juice [30].

**Table 2.3:** Different properties of carrot

	Value	Reference
Cell size of carrot	18-89 $\mu m$	[33]
Cell size of carrot	60 $\mu m$	[34]
Moisture of carrot	87-92 %	[35]
Conductivity of carrot	0.3 $mS/cm$	[36]
Conductivity of carrot	0.33 $mS/cm$	[37]
Conductivity of carrot	0.35 $mS/cm$	[38]
Conductivity of carrot	0.39–0.76 $mS/cm$	[39]
Conductivity of carrot	0.59 $mS/cm$	[34]
Conductivity of carrot	1.6-2.0 $mS/cm$	[40]
Conductivity of carrot mash	2.3 $mS/cm$	[41]
Conductivity of materials suspended in water	1-4 $mS/cm$	[32]
Resistivity of carrot	33.3 $\Omega m$	[36]
Permeability	0.007-0.039 $\mu m^{-1}$	[33]
Conductivity of drinking water	0.05 – 0.5 $mS/cm$	[42]

## 2.7 Local electric field, breakdown in air bubbles

Homogeneous distribution of electric field is one of the fundamental requirements of the PEF treatment chamber. The homogeneity depends on the geometry of the electrodes. However, regardless of the geometry of the electrodes, the homogeneity can be altered if air bubbles are trapped within the food materials. The presence of air bubbles is one of the main challenges that affect the functionality of the PEF system, due to their lower breakdown strength compared to food materials. This lower breakdown strength may cause partial discharge within the food materials if the local electric field exceeds the breakdown voltage. Apart from partial discharge, these air bubbles also causes the distortion of the electric field within the chamber which prompts the total breakdown of food materials at relatively lower voltages than normally expected. The electric field in a spherical gas bubble, inside a liquid with the permittivity of  $\epsilon_{liq}$ , can be described as

$$E_b = \frac{3E_0}{\epsilon_{liq} + 2} \approx 1.5E_0, \quad (2.20)$$

where  $E_0$  is the electric field in the liquid when no bubble is present. From equation above it can be seen that electric field within air bubble will higher than applied electric [43], [44].

## 2.8 Treatment Chamber

A treatment chamber is an enclosure that contains test materials, in this case food, and it is where treatment takes place. The chamber is made of at least two electrodes, held in position by insulating materials. As mentioned in chapter 2.5.2 the more uniformly distributed the electric field is within the chamber, the higher the

efficiency of the chamber. It is therefore important to construct the chamber in a way that enables high degree of homogeneous electric field distribution, to increase the efficiency and make it fit its purpose.

Different studies and experiments indicated that there are constraints that need to be put into consideration while designing the chamber. It is these constraints that dictates the design of the chamber (the shape of electrodes, configuration, and insulating materials) to make it more suitable for the task.

The first constraint is the enhanced field at the edges of the parallel electrodes. If these field enhancements at the edges of the electrodes are not considered during the design, they may cause possible discharge within the food. There are two major techniques to minimize the enhanced field, design of electrodes or increasing the insulation between the electrodes. By using a different shape of the electrodes other than parallel plate electrodes, for instance round-edged electrodes, the field enhancement could be lowered. Parallel plate is the more famous configuration due to its high degree of homogeneity and simple construction. To lower the enhanced field in a parallel plate configuration the ends of the electrodes, the sharp edges, could be inserted inside the insulating material to avoid any possible discharge within the test object [21].

The materials of the chamber is another important aspect when designing the chamber. The chamber should be made of materials that are washable, and autoclavable. Different sources recommend polysulfone and stainless steel as insulator and electrode materials respectively. For electrodes, electrochemically inert materials such as platinum, gold and carbon can be used as well [45].

As mentioned in chapter 2.7 the possibility of having air-bubbles in the substance could cause dielectric breakdown in the food. These air bubbles are either created during filling the chamber with the test materials or/and when putting the lid on the chamber. It is therefore necessary to make a design that facilitates the filling of the chamber with the test object without creating air-bubbles within the food, or between the food and the lid. The design should ensure that air is expelled from the chamber during filling otherwise air-bubbles would initiate partial discharge which could lead to total dielectric breakdown. However, since the air bubbles created when covering the chamber with the lid are the hardest or impossible to avoid, the best option would be to run the experiment while the chamber is not covered with the lid, and this can be done after investigating that electric is not enough to cause breakdown of air at the boundary of food and air [21], [45].

Running the experiment while the chamber is completely covered, may turn out to be dangerous, because when fluid food experiences an arc discharge, high pressure is developed, which may cause the chamber to burst. That is why it is important to consider this aspect while designing the chamber. Depending on the specific objective of the experiment, different mechanisms can be used to avoid potential pressure breakage. For instance in some industrial applications, a pressure release device is

built into the chamber to save it from a possible break off [45], [46].

## 2.8.1 Configuration of electrodes and geometry

As already presented in the previous subsection 2.8 electrodes are one of the most important parts of the treatment chamber. There are several arrangements and geometries of the electrodes to consider when constructing the chamber. Whether the shape or the configuration, both choices should be based on the actual application. Some designs function for both static and continuous treatment chambers while others are optimized for either static or continuous use. In this part, the best configurations for static/batch chambers will be discussed and will be highlighted why they are the most preferred configurations.

### 2.8.1.1 Parallel plate configuration

The parallel electrodes type of arrangement is one the most popular configuration due to two reasons:

- Easy configuration in terms of construction.
- Can achieve high degree of electric field intensity in a large usable area within the treatment zone.

The latter is the main reason why parallel electrode configuration is a good option. Homogeneity is an important factor for high efficiency of the chamber. Even though it is theoretically believed that the electric field intensity between the plates is homogeneous, the statement is based on the assumption that electrodes are infinitely long. With electrodes of finite lengths, areas within the chamber will experience the electric field intensity less than the applied electric field intensity due to fringe effect. Fringe effect will be presented in details under subsection 2.8.2. However, regardless of the fringe effect, different sources have indicated that to achieve high degree of homogeneity within the chamber the gap between the electrodes should be sufficiently smaller than the thickness of the electrodes [21], [45], [46].

Apart from the fringe effect influence on the distribution of electric field within the chamber, this type of configuration also experiences electric field enhancement due to the sharp edges of the electrodes. These field enhancement adds complexity to the design of the chamber, see 2.8, [45], [46].

### 2.8.1.2 Coaxial plate configuration

The second most popular design after parallel plate electrode configuration is the coaxial set up of electrodes. The electrical current flow in this type of chamber perpendicular to the food materials [47]. The electric field strength between coaxial electrodes is;

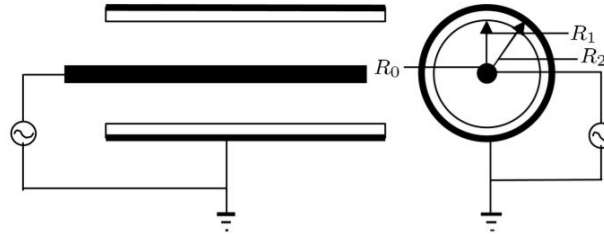

**Figure 2.6:** Simple representation of coaxial treatment chamber [48]

$$E_{co} = \frac{U}{r \ln \frac{R_1}{R_2}} \quad (2.21)$$

where  $R_1$  &  $R_2$  are the inner and outer radii of the electrodes respectively, whereas  $r$  is the radius at which electric field is measured.

### 2.8.1.3 Disk shaped and Round shaped electrodes

Disk shaped and round shaped electrodes are in most cases preferred over parallel plate configuration because of the lower field enhancement, hence reducing the possibility of breakdown within the food materials [47].

## 2.8.2 Fringe effect

The idea that the electric field is entirely uniform between parallel plate electrodes is based on assumption that the length of the electrodes is infinitely long. In reality this assumption is not valid since electrodes are of finite length. Instead the electric field intensity within a 'parallel electrode configuration' is uniform at the center and decreases gradually at the periphery of the electrodes due to fringe effect.

The Figure 2.7 shows how the fringe effect neutralizes the uniformity of the electric field. The coloured regions in yellow, green and blue seen in Figure 2.7 clearly shows the deviation in the electric field within the chamber. The deviation within the chamber lowers the electric field which then lowers the efficiency of the PEF system [49].

To lower the fringe effect and the deviation of the field mainly two techniques can be used. Studies suggest electrodes with a thickness sufficiently larger than the gap between the electrodes and to increase the length of the electrodes beyond effective length. By applying one of the two techniques or a combination of the two the fringe effect can be reduced [50], [51].



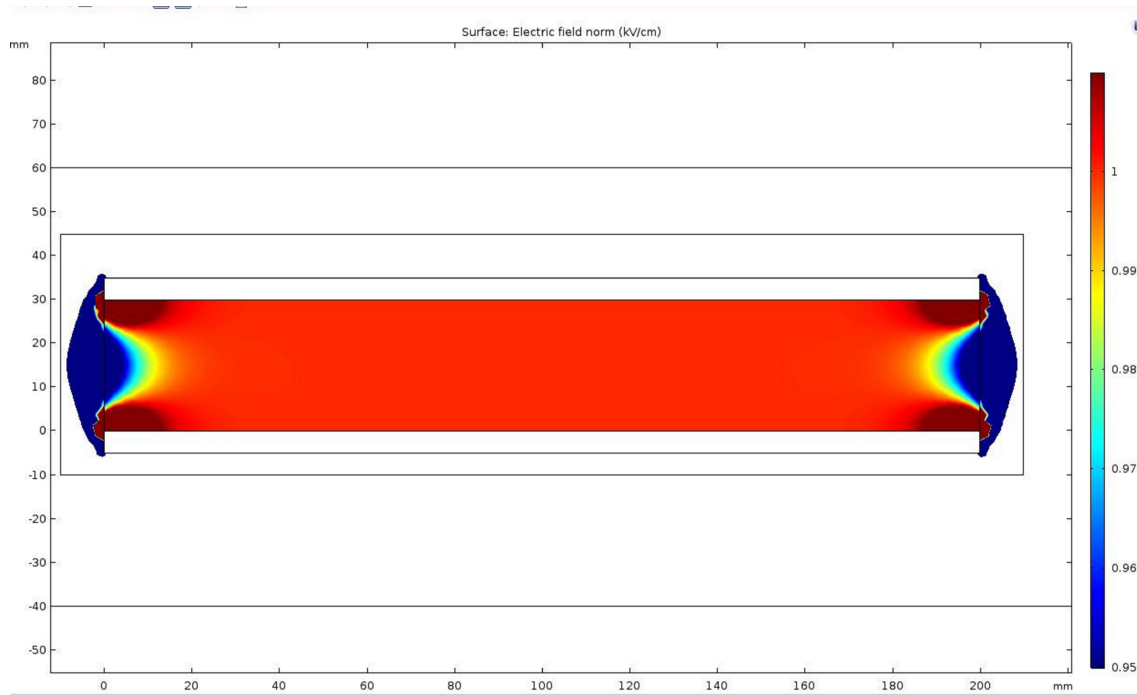

**Figure 2.7:** Heterogeneous distribution of the electric field due to fringe effect

## 2.9 Safety aspects of high voltage test equipment

For a high voltage test area, safety measures must be taken to prevent the possibility of getting in contact with live parts. For safety guidelines an excerpt from the IEEE Standard 510-1983 [52] can be used. The following points are recommended practices taken from the IEEE Standard:

- Precautions should be taken to prevent accidental contact of live terminals by personnel, either by shielding the live terminals or by providing barriers around the area.
- The circuit should include instrumentation for indicating the test voltages.
- High Voltage and high-power tests should be performed and supervised by qualified personnel.
- Appropriate warning signs, for example, DANGER – HIGH VOLTAGE, should be posted on or near the entrance gates.
- Devices which rely on a solid or solid/liquid dielectric for insulation should preferably be grounded and short-circuited when not in use.
- Any open circuited capacitive device should be short-circuited and grounded before being contacted by personnel.
- All objects at ground potential must be placed away from all exposed high voltage points at a minimum distance of 25.4 mm (1 inch) for every 7,500 Volts, e.g. 50 kV requires a spacing of at least 171 mm.

- Allow a creepage distance of 25.4 mm for every 7,500 Volts for insulators placed in contact with high voltage points.
- All high-voltage generating equipment should have a single obvious control to switch the equipment off under emergency conditions.
- During the operation, the entire area should be treated as a hazardous area. No one should enter the area before the voltage supply has been disconnected, and also protective railings shall be used as needed.
- Never take the automatic protective devices for granted, always maintain a sense of personal responsibility and caution.

### 2.9.1 Safety box

An option to prevent accessibility to live parts on a high voltage set-up is to place the test equipment in an enclosure. The materials of the safety box should include one insulating material that covers the inside of the chamber to insulate the outer surroundings from the high voltage that is applied to the test chamber. The safety box should also include one material with good conducting properties to work as a Faraday cage on the outer boundary.

For the enclosure to be safe the material it is made of need to be adapted for its purpose. The material needs to have a dielectric strength high enough to not break down by the voltage applied to the equipment. The dielectric strength of a material depends of factors such as the thickness of the material, the rate at which the applied field is increasing, the shape of the electrodes, and of the material that surrounds the insulator [53]. The dielectric strength is expressed as voltage per distance unit, for a certain material with a dielectric strength of  $x$  V/cm and a voltage of  $u$  V, the minimum thickness needed for the material to not break down is calculated by equation 2.22.

$$Thickness = \frac{uV}{xV/m} \quad (2.22)$$

A Faraday cage is a metal shield that functions as protection to block electric fields and electromagnetic waves. The cage can be designed by either a continuous cover or by a meshed one. How thick the shield needs to be depends on the application of the shield, where what frequencies are needed to be blocked dictate the thickness of the shield. The thickness of the shield need to be at least thicker than the skin depth of the frequencies that are to be blocked [54]. The skin depth in a material with the resistivity,  $\rho$ , for a frequency,  $f_0$ , is calculated by equation 2.23,

$$\delta = \sqrt{\frac{\rho}{\pi f_0 \mu_r \mu_0}} \quad (2.23)$$

where  $\delta$  is the skin depth and  $\mu_r$  and  $\mu_0$  are the relative magnetic permeability and the permeability of free space respectively [26].

Last but not least an enclosure for the test equipment need safe wire drawings through the wall of the enclosure. When passing through the grounded metal wall that the Faraday cage will act like, high electric fields might occur in the vicinity of the passage. To prevent breakdown caused by the high electric field, the passage needs to be done safely by reducing the high electric fields.

The most popular way of insulating conductors of high voltage through a grounded wall is by use of a bushing. A bushing is a hollow insulator that allows high voltage conductor to pass along its centre and connect at both ends to other equipment, mostly power source and the load. The most important task in the design of a bushing is to get the right dimensions that will be able to withstand the stress i.e electrical, thermal, and mechanical stress [55], [56].



# 3

## Methods and set up

This chapter presents the method and set-up that was used when simulating in COMSOL. The chapter also presents the pulse generator that is thought to be connected to the chamber for the future practical experiments.

### 3.1 Set up in COMSOL

In this section the boundary conditions and governing equations used in the COMSOL set-up are presented. The materials for each domain is also presented.

#### 3.1.1 Boundary conditions

The boundary conditions used in COMSOL are shown in table 3.1. The different sub-domains are the electrodes, the insulation, and the test object in between the electrodes.

**Table 3.1:** Boundary condition

<i>Boundary</i>	<i>Condition</i>
High voltage electrode	$V=U$
Grounded electrode	$V=0$
Insulator-electrode-test object	$n. J = 0$

#### 3.1.2 Governing equations

To model the test chamber governing equations were adapted from COMSOL Multiphysics, using the AC/DC module and electrostatic physics.

##### Electrostatics

The governing equations for electrostatic physics are based on charge conservation. The equation for the electric potential can be written as:

$$-\nabla \cdot (\sigma \nabla V - J) = 0 \quad (3.1)$$

where  $J$  is the current density [ $A/m^2$ ] and  $V$  is the electric potential. Equation 3.2 establishes the relationship between electric field and electric potential,

$$E = -\nabla V \quad (3.2)$$

where  $E$  is the electric field strength (V/m).

### 3.1.3 Materials

The table 3.2 shows the materials used in the model together with their most important parameters.

**Table 3.2:** Simulation Parameters

Domain	Material	Relative Permittivity	Conductivity [S/m]
Electrodes	Stainless steel	1	-
Insulator	Teflon	2.08	-
Test material	Carrot and water	-	0.026

## 3.2 Specifications of the pulse generator

The pulse generator that is thought to be used in the future project and therefore is the starting point of the thesis work is a Saligus 10 kW modulator. The modulator is constructed of a DCPS that converts the 3-phase voltage to a regulated DC voltage. This voltage then charges up the IGBT Modules to a voltage around 1000 V. The IGBTs are high-power solid-state switched and are controlled electronically by a trigger pulse. The modulator consists of a pulse transformer and a HV-load interface that are surrounded by transformer oil. The modulator has two outputs and the limitations of the modulator output can be seen in table 3.3. There is also a built-in protection in the modulator that will prevent the modulator to operate in certain settings. The settings that must not be exceeded can be seen in table 3.4.

**Table 3.3:** Limitations of generator output

Parameter	Min	Max	Unit
Load voltage set:	0	50	kV
Pulse width set ( $< 300 \Omega$ ):	2.2 (2.8)	10	$\mu$ s
Pulses to count:	0	32000	-
Prf out:	16	1000	Hz
Load res:	100	2500	$\Omega$

**Table 3.4:** Limitations in settings that the protection will prevent

Settings $>10$ kW average
Settings $>5$ MW peak
Settings $>0.2$ % duty

# 4

## Design of the batch chamber

This chapter presents the main result of this project; the design of the test chamber. In this chapter three different designs are presented as well as a comparison of the designs. The design include geometry (volume and dimensions of the chamber), choice of materials, and design of the electrodes and insulation. The chapter also includes the result of whether a lid is needed on the chamber.

### 4.1 Geometry and size of the chamber

The three different designs all have the same treatment volume, which as presented in the problem description was a requirement from RISE to have a volume of 3 dl, see 1.3. All three designs have the same treatment volume in the chamber where the press cake of carrot will be placed, but depending on the electrode and insulation design, presented later in the chapter, the outer dimensions of the chambers might differ. In this section the dimensions of the treatment volume will be presented, for the outer dimensions of each chamber, see table 4.1.

The dimensions of the chamber need to fit several requirements, as already mentioned the volume should be 3 dl. The requirements from RISE that affect the dimensions of the chamber is:

- Volume: 3 dl
- Longest allowed dimension: 20 cm
- Gap between electrodes: 3 cm

The pulse generator has a restriction of the load to be in the range of 100 - 2500  $\Omega$ . All the mentioned requirements need to be considered when the dimensions of the chamber are decided.

When designing the dimensions of the chamber to fit the range of the resistance required from the generator, the conductivity is a decisive parameter, see equation 2.3 in the theory section. Based on the collected values of the conductivity of carrot and the fact that the conductivity decreases when juice (water and nutrients) are extracted from the tissue, the value of press cake can be considered to be lower than the collected values for pure carrot. However, during the treatment the press cake will be inserted into water to create a larger contact area for the treatment, therefore the conductivity will be changed due to the water. With a conductivity

of  $0.5 \text{ mS/cm}$  for water, see table 2.3, the conductivity of the test object will be slightly increased. As an example, if the conductivity of press cake of carrot is  $0.2 \text{ mS/cm}$ , and the chamber being filled with 80 % press cake of carrot and 20 % water, the conductivity would be increased to a value of  $0.26 \text{ mS/cm}$ , calculated as

$$\sigma_{tot} = \sigma_{water} \cdot 0.2 + \sigma_{presscake} \cdot 0.8, \quad (4.1)$$

where  $\sigma_{tot}$  is the conductivity of the press cake of carrot mixed with water and  $\sigma_{water}$  and  $\sigma_{presscake}$  is the conductivity of water and press cake of carrot, respectively. If the chamber would have a higher content of water, the conductivity would be increased even further.

With a conductivity below  $0.3 \text{ mS/cm}$  for press cake of carrot, the dimensions of the chamber have been found through equation 2.3. The dimensions of the treatment volume have been chosen to:

- Gap distance: 3 cm
- Length: 20 cm
- Width: 5 cm

These dimensions give a volume of 3 dl and a resistance above 100  $\Omega$ .

## 4.2 Materials of the Chamber

All three designs of the chamber are made from the same materials as described in the COMSOL set-up in section 3.2. The material used for the electrodes is stainless steel, the insulator is made from Teflon (PTFE). Stainless steel has many advantages as a material where the main reason to choose stainless steel is its corrosion resistance. Other important properties of stainless steel for this project are for example:

- Ease of fabrication
- High strength
- Hygiene and ease of cleaning
- Long life cycle
- Recyclable [57].

Teflon is firstly used for its non-stick property as it is easy to clean the chamber when the insulator is made out of Teflon. Other properties of Teflon are:

- Chemically inert (not chemically reactive)
- Highly insoluble in most solvents
- Can be used in the range of  $-200^\circ \text{ C}$  and  $+260^\circ \text{ C}$
- High electrical resistance and dielectric strength ( $> 10^{18} \Omega \text{ cm}$  and  $60 \text{ MV/m}$  ( $1 \text{ MHz}$ )) [58]



### 4.3 Design of test chambers

In this section the three different designs of the chamber are presented. They all have the same dimensions for the treatment volume and all three consist of the same materials presented in the earlier section. The three chambers are based on the 'parallel electrodes configuration' which has the advantages of easy construction and large usable area with homogeneous field, see chapter 2.8.1.1. What separates them is the design of the electrodes as well as the design of the insulator.

The first design simply consists of two parallel electrodes where the entire volume in between the electrodes is used as the treatment zone. The electrodes are covered with insulation material on the outer side of the chamber, see Figure 4.1. The outer volume of design one is  $1040\text{cm}^3$ .

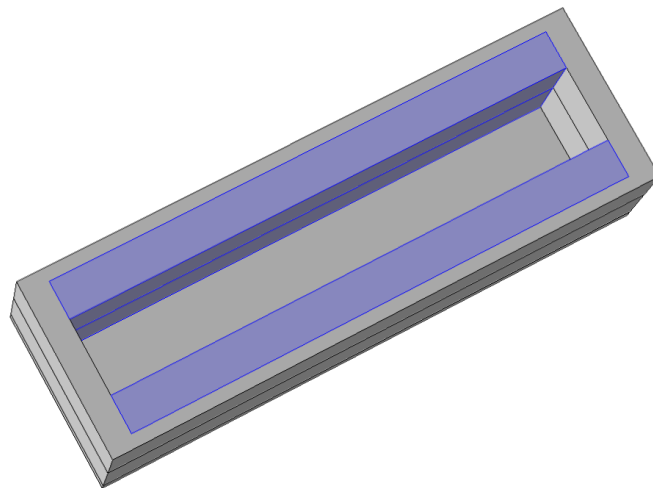

**Figure 4.1:** Chamber design option 1

In the second design the electrodes are inserted into the insulation material, hiding the edges of the electrodes from the treatment zone, see Figure 4.2. This gives a thicker layer of insulation at the edges of the electrodes. In the second design the entire volume in between the electrodes are not used as the treatment zone as some of the volume have been replaced with insulation. The treatment volume has the same size, 3 dl, instead the outer dimension of the chamber is increased compared to the design number one. The outer volume of the chamber is  $1800\text{cm}^3$ .

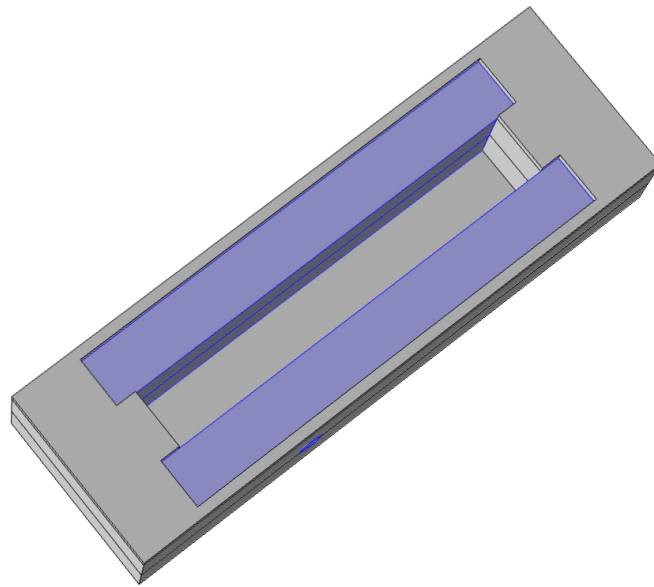

**Figure 4.2:** Chamber design option 2

The third design option of the chamber is presented in Figure 4.3. As in the second design the ends of the electrodes have been inserted into the insulation. What differs the second and the third option is that for the third design, the electrodes have not only been inserted into the insulation, the edges of the electrodes have also been rounded to minimize the sharp edges. The outer volume of the chamber is  $2187\text{cm}^3$ .

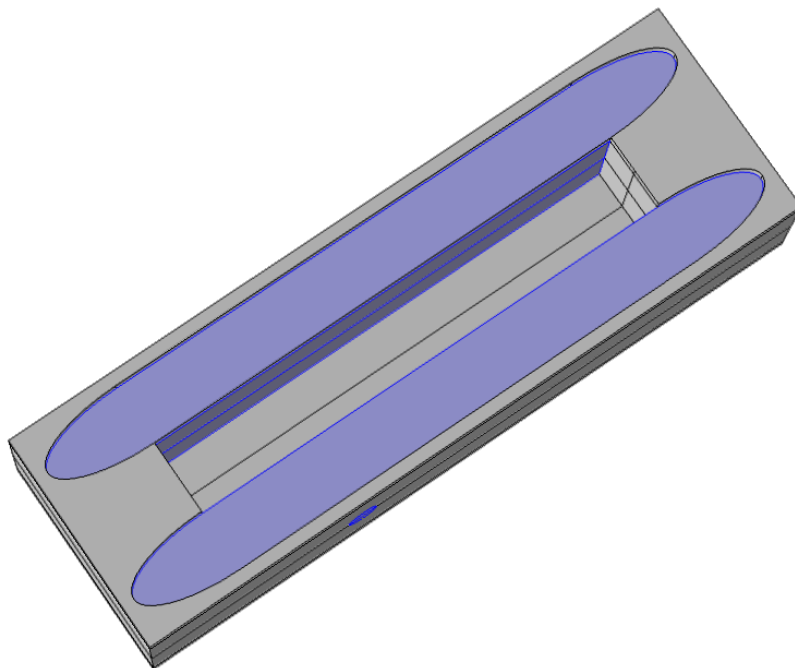

**Figure 4.3:** Chamber design option 3

To summarize the different designs that have been examined in this project, the

differences for each design are:

- Option 1: Simple parallel electrodes configuration
- Option 2: Parallel electrodes inserted into insulation
- Option 3: Rounded electrodes inserted into insulation

## 4.4 Design of electrodes

In this section the simulations to optimize the design of the electrodes are presented. The optimization includes the thickness of the electrodes, as well as the shape of the electrodes.

### 4.4.1 Electrode Thickness

In theory section 2.8.1.1 it states that the thickness of the electrodes contributes to a uniform distribution of the electric field within the chamber. Figure 4.4 shows the increase of the electric field by increasing the thickness of the electrode. The point in the chamber where the electric field is shown is at the periphery of the treatment volume, which is the region with the lowest electric field see point A in Figure 4.5.

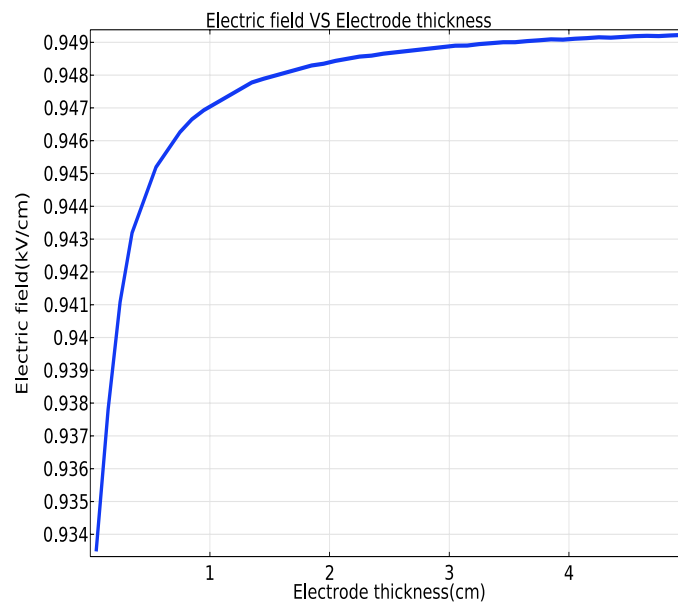

**Figure 4.4:** Effect of electrode thickness on the electric field distribution

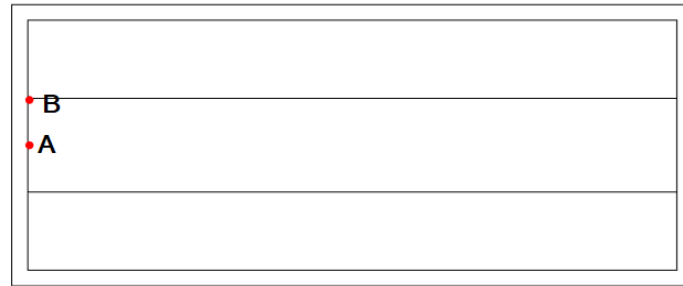

**Figure 4.5:** Reference points for the lowest, A, and highest, B, field in the chamber

From Figure 4.4 it can be seen that the electric field in point A increases with the thickness of the electrode. The aim is to have the same electric field trough-out the whole treatment volume, where  $1\text{ kV/cm}$  is the voltage applied to the electrodes. Considering keeping the outer dimensions of the chamber small, the thickness of the electrodes was chosen to the length of  $0.025\text{m}$ .

The main goal of increasing the thickness of the electrodes is to make sure that every point within the chamber experiences the required electric field intensity ( $1\text{ kV/cm}$  for this case). However according to Figure 4.4 even when the thickness of the electrode was increased to almost double the gap length, still the required field was not reached. The electrode thickness alone is not enough to achieve uniform distribution of electric field within the entire chamber, instead it only increases the effective volume to some extent.

#### 4.4.2 Electrode shape

In design 3 to minimize the enhanced electric field at the sharp edges of the electrode, the end parts of the electrode are changed to an elliptic shape of radius " $a$ " see Figure 4.6. A parametric sweep study of the radius " $a$ " was done where the electric field at the enhancement point B, see Figure 4.5, were studied. The graph of the enhanced field is shown in Figure 4.7. From the figure it is inferred that the enhanced field can be minimized to or very close to the actual applied electric field by increasing " $a$ ".

From the figure it can be seen that for any radius above  $0.02\text{m}$  the enhanced field is close to  $1.05\text{kV/cm}$ . To keep the outer volume of the chamber reasonably small and at the same time lower the enhancement of the field, a radius with the length of  $0.03\text{m}$  was chosen for the design.

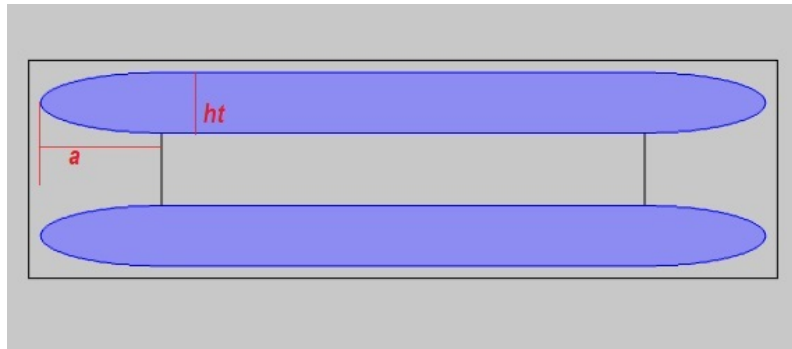

**Figure 4.6:** Rounded electrode chamber in 2D view

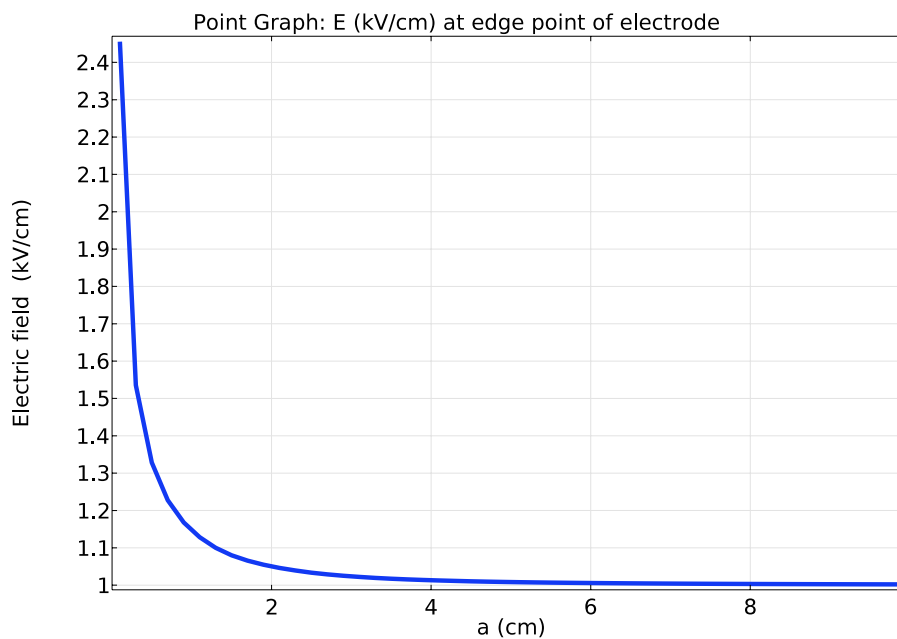

**Figure 4.7:** Parametric sweep of the radius "a"

## 4.5 Insulation

In this section the length of the insulation in between the electrodes is presented for design 2 and 3. The addition of insulation in between the electrodes was simulated to minimize the effect of the fringe effect inside the treatment chamber. The insulation can also be called a spacer, see Figure 4.8 for the position of the insulation/spacer. As the electrodes have different shapes for the two designs the lengths of the spacers are examined separately for the two designs. The electric field has been simulated for different lengths of the spacer, see Figure 4.9 and 4.10 for the spacer length for design 2 and design 3 respectively.

For design 2 it can be seen in Figure 4.9 that the electric field is close to the set value 1 kV/cm for a spacer length above 0.02 m. As for design 3 the same value is only reached for a spacer length above 0.06m. The graphs show that for design

#### 4. Design of the batch chamber

---

3 with the rounded electrodes a longer spacer is needed. In the designs, the spacer length for design 2 was chosen to 0.025m. The length of the spacer for design 3 was chosen to 0.03m.

The motivation for this design is to have the field enhancement points of the parallel plate electrodes inserted within the insulator materials to avoid possible discharge within the food materials. The design also minimizes heterogeneity distribution of electric field due to fringe effect.

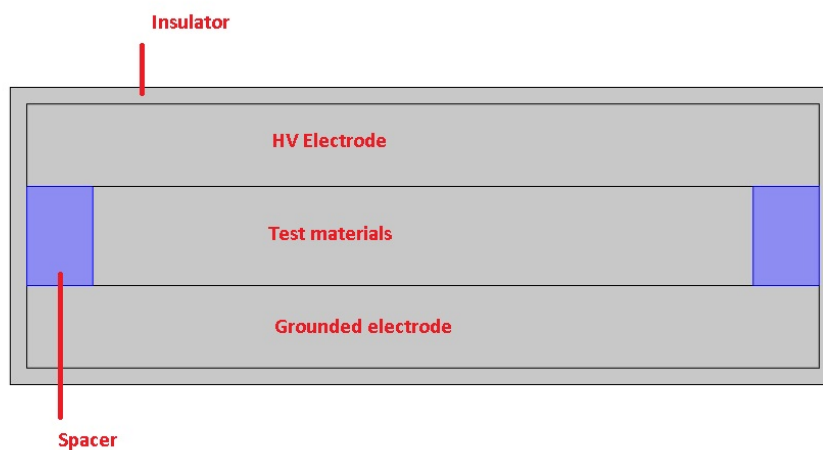

**Figure 4.8:** Position of the spacer from 2D View

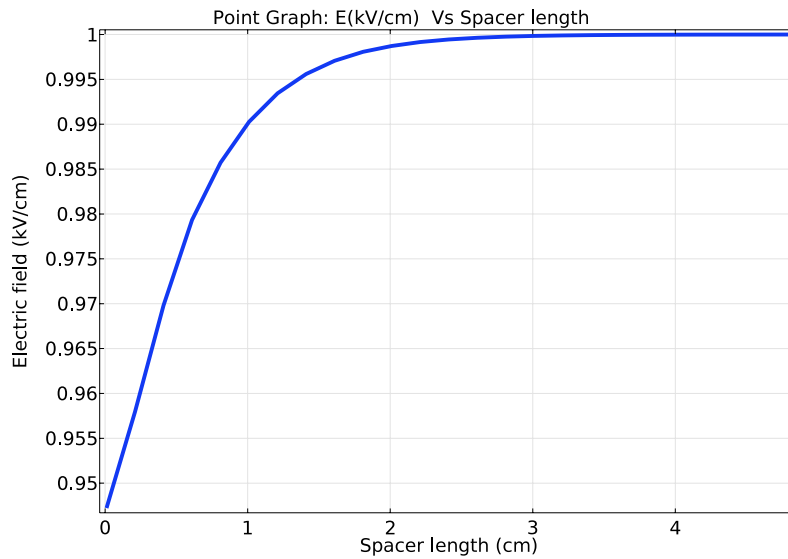

**Figure 4.9:** Spacer optimization for design 2

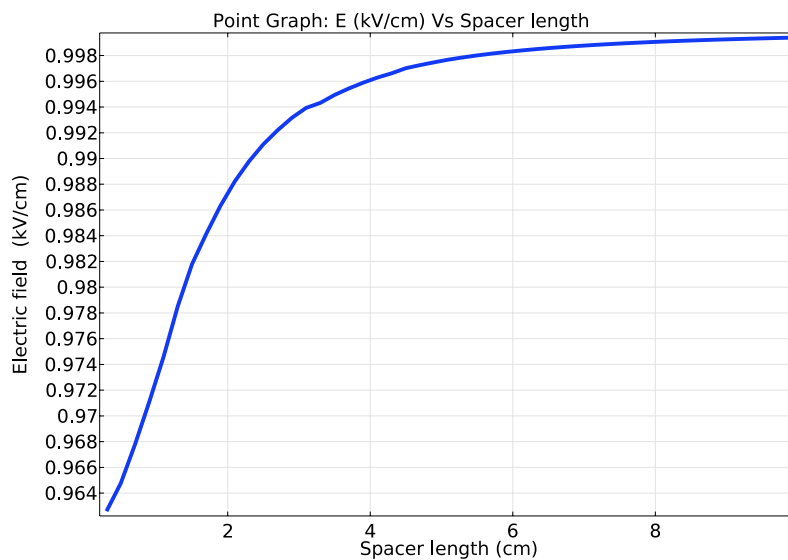

**Figure 4.10:** Spacer optimization for design 3

## 4.6 Enhancement of electric field

Enhanced electric field occurs at the sharp edges or points at the electrodes. Since the enhanced field could be higher than the set electric field, there is a possibility of partial breakdown within the food materials. For each design the highest enhanced field was observed, see table 4.1 for comparison of the different designs.

From table 4.11 it can be seen that for design one and two, the enhanced field is high, and it increases with the increase of voltage compared to the required field. For example an applied electric field of  $16\text{ kV/cm}$  would result in an enhanced field

## 4. Design of the batch chamber

---

close to  $28\text{kV/cm}$ . In the same figure, it can be seen that for design 3 there is no big difference between the required electric field and the enhanced field. The rounded design of the electrodes has reduced the enhancement of the electric field.

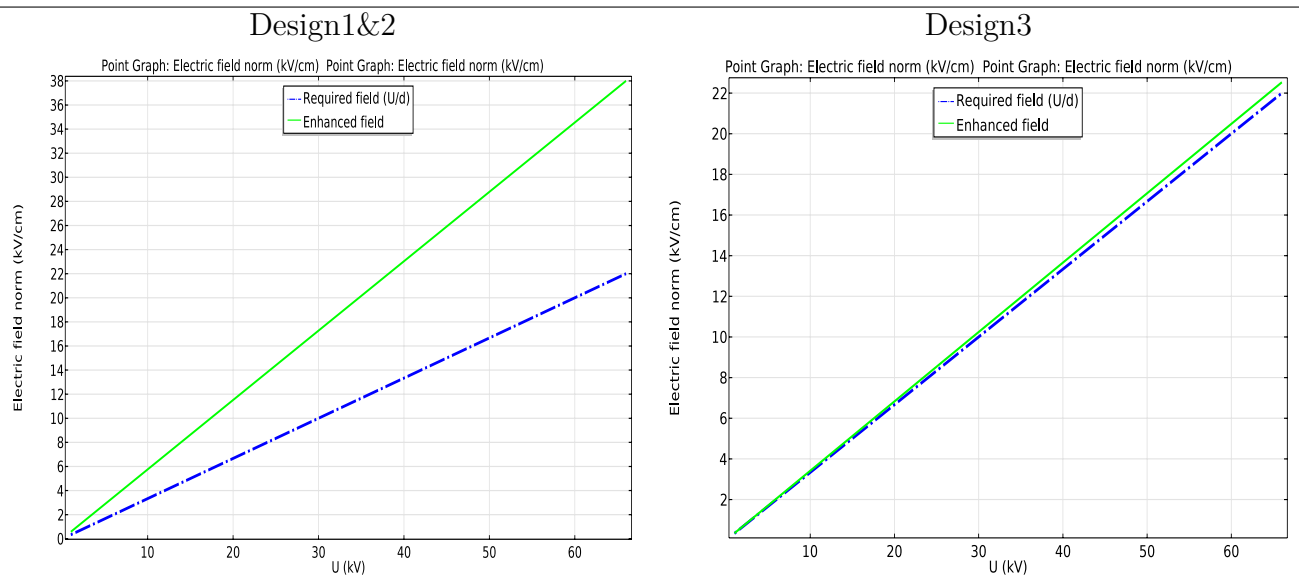
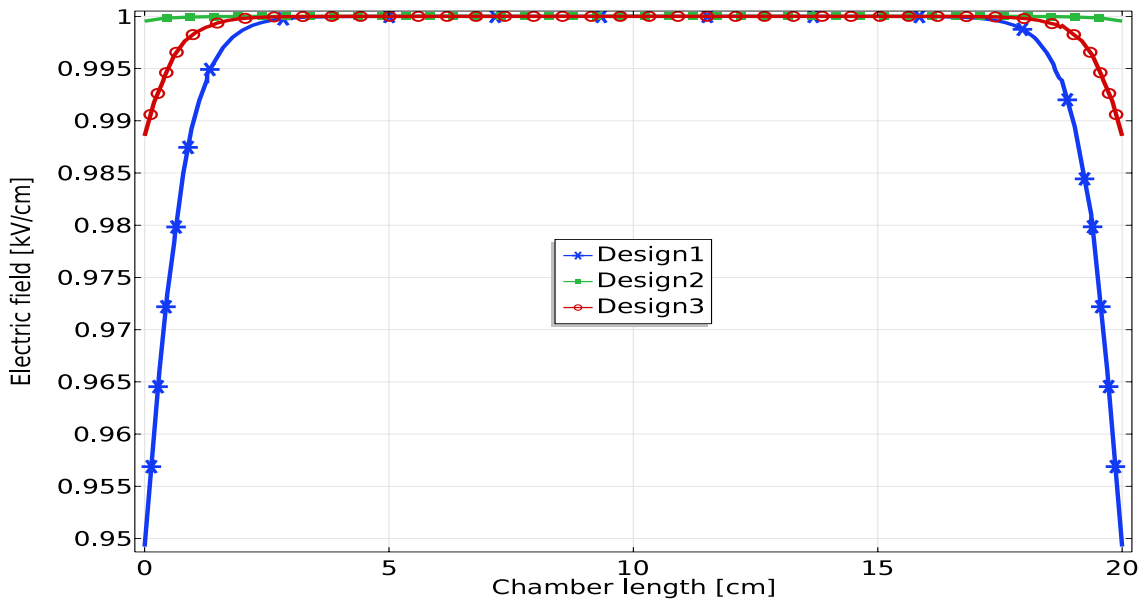

**Figure 4.11:** Comparison between the required electric field and enhanced field.

## 4.7 Comparison of the three designs

Figure 4.12 shows that design 1 has the smallest effective volume compared to the other two designs. This can be seen as the curve for design 1 only reaches the electric field strength of  $1\text{ kV/cm}$  for a length of  $140\text{ mm}$ . Both design 2 and design 3 have a longer area where the electric field is  $1\text{ kV/cm}$ . Design 2 and design 3 have higher effective volumes simply because both designs minimize the influence of fringe effect.





**Figure 4.12:** Comparison of all three designs

For comparison of all three designs, see table 4.1 where the length of the insulation, the effective volume and the highest enhanced field are presented among other parameters for the designs. The outer volume presented in the table is the full volume of the chamber including the electrodes and the insulator. The treatment volume for all three designs are  $300\text{cm}^3$  while the outer volume varies depending in the design options.

**Table 4.1:** Comparison of the three designs

	Design 1	Design 2	Design 3
Design of electrodes	Rectangular	Rectangular	Rounded
Length of insulation (spacer)	none	$2.5\text{cm}$	$3.0\text{cm}$
Effective volume	83 %	96 %	96 %
Treatment volume [ $\text{cm}^3$ ] (% of outer volume)	300 (28.3)	300 (16.6)	300 (13.7)
Outer volume [ $\text{cm}^3$ ]	1040	1800	2187
Highest enhanced field	$1.8E_{th}$	$1.90E_{th}$	$1.025E_{th}$

## 4.8 Running experiment without lid on the chamber

In the theory section 2.8 it is described that one of the concerns for PEF treatment is breakdown in the test material due to the presence of air bubbles inside the test object. When covering the chamber with a tight lid, bubbles may get trapped between the lid and the surface of the carrot, causing discharge. Therefore, a simulation was made to evaluate if the treatment is possible to run without an insulation-lid on top of the chamber, leaving one of the sides of the chamber (the one pointing upwards)

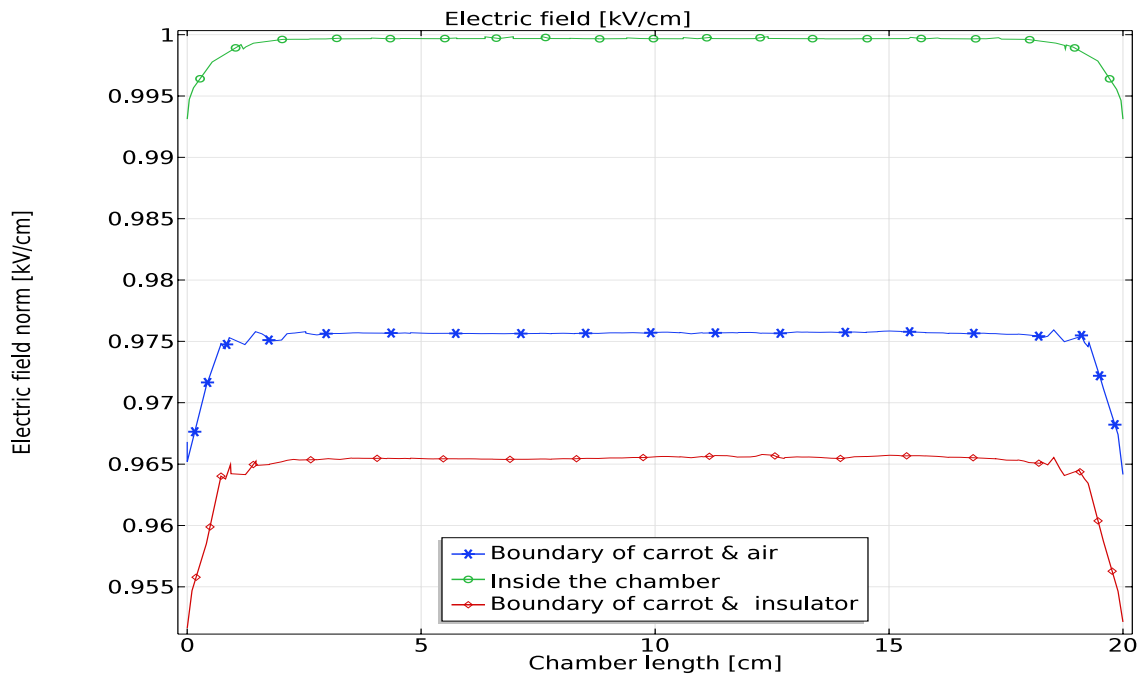

**Figure 4.13:** Electric field at the boundaries of the chamber without lid

without insulation from Teflon.

The result from the simulation to investigate the possibility of running the experiment without a lid is shown in Figure 4.13 where the electric field at the respective boundaries in the chamber is shown. As can be seen, the electric field at the boundary of air-carrot is 97% of the applied electric field. The boundary of air-carrot is on the top of the chamber, leaving the surface of the carrot in contact with the open air. For the experiment to be run without the lid, the electric strength must be low enough to not cause a breakdown in air.

With a breakdown voltage of air at 30kV/cm and a distance of 3 cm between the electrodes, the chamber could be supplied with a voltage of 90 kV without a lid. The breakdown voltage of air could however have a considerably lower value depending on for example electrode shape, moisture and pressure. With a breakdown voltage for air at 17kV/cm the maximum applied voltage without lid would instead be 51 kV. The maximum voltage that can be supplied by the generator is 50 kV, therefore the chamber connected to the generator can be used without a lid.

## 4.9 Final dimension

The final dimensions for design two is shown in the table 4.2. Figure 4.14 show the design of option number 2 and Figure 4.15 show the electric field inside the treatment volume.

**Table 4.2:** Dimensions for Design 2

Symbol	Description	Dimension
$r$	Distance between electrodes	3 <i>cm</i>
$l$	Length of treatment zone	20 <i>cm</i>
$t_e$	Electrode thickness	2.5 <i>cm</i>
$t_i$	Insulator thickness	0.5 <i>cm</i>
$d$	treatment zone depth	5 <i>cm</i>
$l_t$	outer length	27 <i>cm</i>
$d_t$	outer depth	8 <i>cm</i>
$h_t$	outer height	9 <i>cm</i>
$l_s$	Length of spacer	2.5 <i>cm</i>
$V_o$	treatment zone volume	300 <i>cm</i> <sup>3</sup>
$V_t$	outer volume	1800 <i>cm</i> <sup>3</sup>
$V_{eff}$	Effective volume	96%

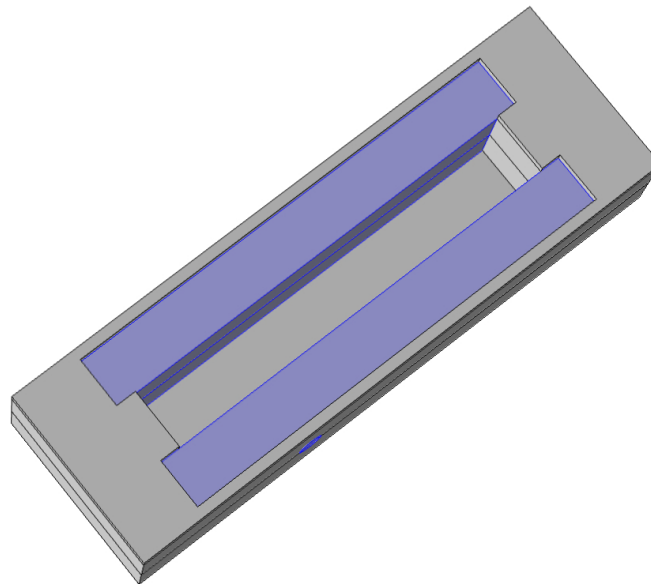
**Figure 4.14:** Chamber design option 2

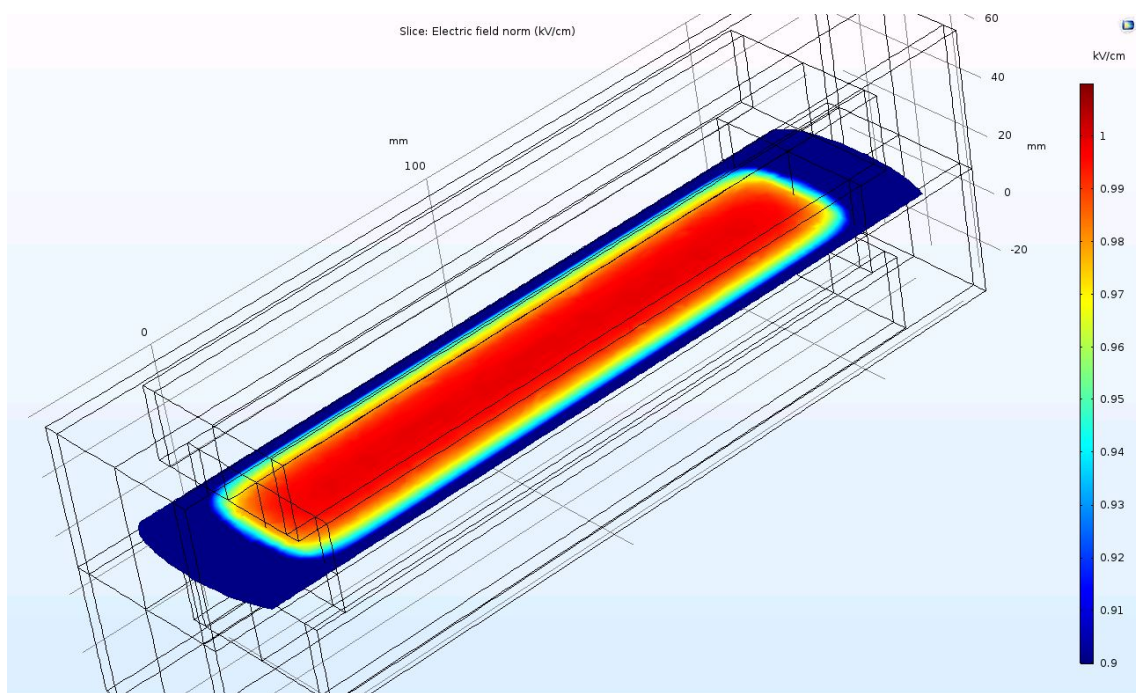

**Figure 4.15:** 3D view of Electric field inside treatment zone.

# 5

## Pulse characteristics

This chapter focuses on the parameters of the pulse. Since the project is only based on theoretical assumptions no specific values for PEF treatment on carrot will be presented. Instead this section will summarize the theory written in chapter 2.2 about the different parameters described there. The set-up for the future research with the PEF equipment can be based on this summary.

In the theory section, factors that define optimal pulse parameter values are described in order to receive an efficient PEF treatment. These are in summary:

- Low electric field, to not increase the temperature in the tissue.
- Long treatment time  $\tau_s$
- Short pulse width, to avoid temperature increase.
- As close to ideal square wave as possible.
- Bipolar pulse shape, for higher damage degree.
- The subsequent pulses should be spaced with long time in between, to increase the electroporation time.

Several different pulses can be used for the PEF treatment but according to the theory these are the factors to focus on. When conducting PEF research, various methods can be chosen. The PEF treatment can focus on applying a constant energy content for each treatment, the focus could also be to always apply the same electric field. If the goal is to apply the same energy to all treatments this could be done in many ways by varying the pulse parameters accordingly.

If the value of the voltage applied to the test object changes, there will be a different energy content for each pulse. To achieve the same energy for each treatment the other parameters must be adapted. When one parameter changes, the other parameters need to be changed as well, to keep the same energy content. The parameters that are most likely to be changed are the voltage applied from the generator, the length of the pulses, as well as the number of pulses. Table 5.1 shows examples of how the parameters can be changed to keep a constant value. Note that this is an example of how to keep the PEF energy constant, and that this is just one method for doing so. As mentioned in chapter 2.2.1 the electric field is the most important factor for PEF and therefore constant energy might not even be interesting to study for the case of press cake of carrot.

In table 5.1 the energy per pulse has been calculated from the energy formula containing the resistance, equation 2.8, and the total energy has been calculated by

**Table 5.1:** Examples of how to achieve the same total energy with different settings

Voltage [V]	Pulse length [ $\mu s$ ]	Energy/pulse [J]	Number of pulses	Total energy [J]
6000	3	1.08	1852	2000
6000	10	3.6	555.5	2000
12 000	10	14.4	138.8	2000

equation 2.10. As can be seen in table 5.1, if the pulse length is short the energy per pulse will be low and therefore the number of pulses needs to be large to reach the same energy as for a pulse with the same voltage but a with longer pulse. It can also be seen that if the voltage is doubled and the pulse length is kept constant, the number of pulses needed to keep a constant energy is only one fourth of what is needed for half the voltage.

# 6

## Practical design

This chapter presents the results regarding the practical design. The practical design includes the couplings needed to connect the chamber to the generator, and the design of the safety box that is required to ensure that no live parts are accessible.

### 6.1 Coupling of the set-up

An interlock is needed to secure the test set up, in such a way that it is impossible to run the generator, connected to the test chamber inside the safety box, without closing the lid of the safety box. For the circuit of the interlock, see Figure 6.1. The two switches in the interlock circuit can only be closed when the lid of the safety box is closed. With the use of a relay the interlock can be controlled by closing the lid without applying the same voltage that is fed to the generator to the circuit with the switches.

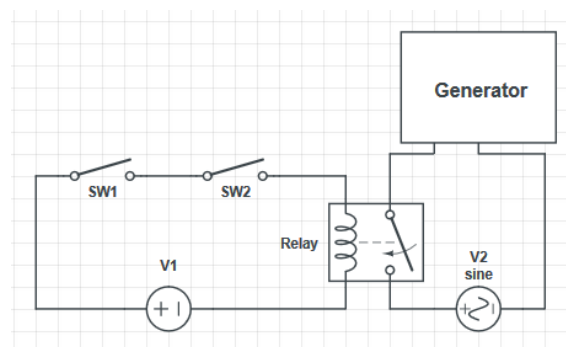

**Figure 6.1:** Circuit of the interlock

The full set up of the treatment system including the pulse generator, safety box, test chamber and interlock circuit can be seen in Figure 6.2.

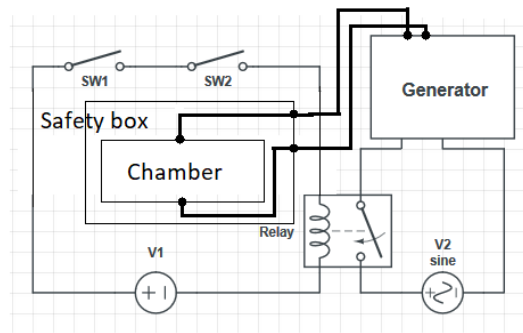

**Figure 6.2:** Set up of selected system with generator, safety box and test chamber

## 6.2 Safety box

The result that is presented in this section is based on a recommended minimum for the safety box. As mentioned in section 2.9.1 there is an option to solve the safety aspects of the test equipment by placing the test equipment in a closed box. In this project the following aspects have been studied for such a safety box:

- Size and geometry of the box
- Choice of material and thickness
- Carrying cables through the wall of the box in an effective way.

### 6.2.1 Size and geometry of the box

The size of the safety box should be large enough to fit the chamber, including the connectors and the wires inside. It may even be advisable to construct the safety box large enough to contain a chamber of a larger size, for the case that research activities at RISE would need a larger batch chamber. Based on the size of the proposed batch chamber, a safety box size as summarized in table 6.1 would be suggested.

**Table 6.1:** Dimension of chamber and safety box

Size of proposed chamber	0.25x0.09x0.08 m
Extra margin for larger chamber	0.1 m
Size of safety box	0.35x0.19x0.18 m



**Table 6.2:** Properties for materials under consideration for safety box [59]

	Stainless steal	Polypropylene, PP
Electric resistivity ( $\Omega.m$ )	$6.9 * 10^{-7}$	$10^{14} - 10^{16}$
Dielectric strength	-	30-40 kV/mm
Upper working temperature (C)	-	90-120

### 6.2.2 Choice of materials for the safety box

The choice of materials for the safety box has been done based on the materials RISE already has the experience to work with. As insulating material, the plastic polypropylene has been chosen and for the conducting material stainless steel is to be used. Both the materials have the advantage of being food graded, easy to clean and are affordable. For properties of the chosen materials, see table 6.2.

For calculation of the thickness of the insulator the theory from chapter 2.9.1 have been used. With a dielectric strength of 30-40 kV/mm for polypropylene and a highest possible voltage of 50 kV supplied by the generator, the shortest distance that is needed for the insulator can be calculated by equation 2.22 as

$$Thickness = \frac{50kV}{30kV/mm} = 1.6667mm, \quad (6.1)$$

where the thickness of the insulation should be the minimum of 1.6667 mm. From theory section 2.9 the safety standard suggests a safety margin of increased distance by a factor of 10. Leading to the insulator having a minimum distance of 16.667 mm.

### 6.2.3 Cables through the wall

As read in theory chapter 2.9.1 there is a need to use extra insulation around the cables when they are passed through grounded conducting walls. As the cables carried through the safety box could carry up to 50 kV a so called bushing would be needed. With a voltage up to 50 kV the insulator on the bushing would need to be of a large size. Instead of using the technique of bushings a shielded wire will be used. The shielded wire will be passed through the metallic wall. The grounded shield, surrounding the cable, will be connected through a connector to the grounded metallic cage. Thereby the cable is grounded with the conducting wall and can be passed through.

The practical design can be summarized by the following points:

- Interlock with two switches to ensure closed lid during active treatment
- The size of the safety box should at least be 0.35\*0.19\*0.18 m to fit the chamber including possible larger chambers used in the future
- The insulator made of polypropylene needs to be at least 1.6667 mm to prevent break-down, but the safety margin of 10 times thicker insulation gives a thickness of minimum 16.667 mm

## 6. Practical design

---

- The cables can safely be passed through the conducting wall by connecting the grounded shielding of the cable to the conducting wall, thus letting them have the same potential.

# 7

## Discussion

In this chapter a discussion of the results as well as an overall discussion of the project is presented. The discussion includes a discussion of the different chamber designs, the pulse shape for PEF treatment, the uncertainty of conductivity, and PEF chambers for other materials. The chapter also includes a discussion about the limitations of the work as well as the improvements that can be done and future works.

### 7.1 Design of chamber

As can be seen in chapter 4, three different designs have been simulated. Design 1 has the advantage that it is a design easy to manufacture with simple rectangular electrodes and the insulation covering the electrodes to form structure for the design. However, the design does not fulfill one of the requirements from RISE, namely that at least 95 % of the treatment volume should have the correct electric field value ( see chapter 1.3). Design 1 only provides an electric field where 83 % of the treatment volume is being treated with the applied electric field. This leaves design 1 to not be a good alternative for the PEF treatment.

Design 2 is, just as design 1, an easy design to build with rectangular electrodes. Here the electrodes have been inserted into the insulation to avoid enhanced fields inside the treatment volume. For design 2, 96 % of the treatment volume is being treated with the set electric field and therefore it fits the requirement from RISE to be used in the PEF treatment. One downside of design 2 is that because of the rectangular electrodes, and therefore sharp edges on the electrodes, there is still a high enhancement of the electric field. Since the edges of the electrodes are inserted into the insulation the enhanced field is not affecting the treatment volume. Instead the electric field is enhanced in the insulation. This might lead to a limitation of design 2. To avoid breakdown of the insulation, the applied electric field must be controlled below the breakdown voltage of Teflon, which is being used as the insulation in the design.

Design 3 has the same effective volume percentage as design 2, i.e. 96 % of the treatment volume is being treated with the set electric field. Compared to design 2 the third design has a more complicated design to build, as the electrodes are rounded. This complicates the design of both the electrodes as well as the insulation, as the insulation must be formed to fit with the rounded electrodes. Design 3

also has longer electrodes as the spacer is needed to be longer for the third design. The length of the electrodes leads to an increase of the outer dimensions. For design 3 only 13.7 % of the total volume can be used as the treatment volume, compared to design 2 where 16.6 % of the volume stands for the treatment volume. In that sense design 2 is the more effective design. Design 2 has shorter length of the electrodes, thus saving materials and is easier to build.

For all three designs the lengths of the spacer and the thickness of the electrodes have been selected to gain as high homogeneity as possible but still keep the dimensions of the chamber small to achieve economical use of the materials. The design should also be kept reasonably small for ease of working with it in the lab.

As mentioned for design 2 there is still a high enhancement in the insulation. Here design 3 have an advantage because of the rounded electrodes. The rounded electrodes lower the field enhancement and the applied voltage is not as critical as for design 2. Design 2 is the more optimal design regarding size and ease of construction, but if a high voltage would be applied, design 3 would have the advantage as the rounded electrodes decrease the enhancement of the field.

In chapter 4 (the design of chambers) it is stated that the chamber can be used without a lid on top of the chamber. This is because the electric field is not enhanced above the chamber and therefore no breakdown will appear in the air. What is important to mention is that this only applies for voltages below the breakdown voltage in air. For higher voltages a lid would be needed.

## 7.2 Pulse settings

As explained in chapter 5, the theoretical nature of this study makes it difficult to conclude any specific numbers or settings for the specific pulses that should be applied for PEF treatment on carrot. As mentioned, most of the parameters regarding the pulses vary a lot depending on the specific characteristics of the tissue. There are also several ways of conducting the research where one can focus on applying the same constant specific energy, or focus on the electric field value or pulse length. As there are several methods to conduct PEF treatment, the optimal characteristics of the applied pulses can only be found through practical experiments. Chapter 5 only presents guidelines on how to produce an optimal pulse. The chapter focuses on effective damage and to keep the temperature low in the tissue. Table (5.1) with different settings, all of them resulting in 2 kJ treatment, shows how the pulse parameters are related to each other and how they affect the specific energy. What is important to mention once again is that practical research might find that the energy level of 2 kJ is not appropriate for PEF treatment on carrot, the energy level is only chosen as an example. It might also be found that keeping a constant energy level is not of importance.

### 7.3 Uncertainty of conductivity

The conductivity of press cake from carrot has not been available during the project. Instead several values of the conductivity of carrot have been collected. Based on the fact that the conductivity decreases when juice and ions are extracted the conductivity of press cake can be assumed to be lower than the collected values for fresh carrot. As the pulse generator has a requirement of the load to be in the range of 100 - 2500  $\Omega$  the resistance needs to be above 100  $\Omega$ . If the conductivity of press cake would be higher than what has been estimated here, the resistance of the load might be too small. If the conductivity would lead to a resistance lower than 100  $\Omega$  the shape of the chamber would need to be altered. The first option to increase the resistance would be to increase the distance between the electrodes. A smaller contact area for the electrodes might also be needed to enable a higher resistance.

In coming experimental work, the press cake will probably be mixed with water before being placed in the chamber. Hence, in this study, conductivity has been calculated based upon an example of 80 % press cake and 20 % water. Depending on the texture of the press cake more water might be needed to assure a good contact between the tissue and the electrodes. This will also affect the resistance of the chamber. With ohmic losses caused by the current flowing through the tissue the temperature might increase in the tissue. With an increase in temperature the conductivity might increase as well.

### 7.4 Test chamber for other materials

This project has focused on the treatment of press cake made of carrot. Therefore, no properties for other materials have been investigated. If other materials would be of interest to treat with PEF there would in principle not be any problem to use the same chamber. Yet, if the conductivity would be much higher than the conductivity that has been accounted for here, the resistance of the load might turn out to be too low for the generator at RISE. Because of that, it may very well be that not all materials can be used in the chamber that has been designed in this project. Also, as the specific energy, electric field and pulse length depend on the properties of the tissue these parameters might be needed to be adapted for the new material, to achieve the most efficient treatment. Other requirements for the material is that it would have to be able to withstand high electric field, as well as that air bubbles must not be created inside the test object.

### 7.5 Limitations

The main limitation of this project is the fact that the project has only been conducted theoretically. The design has not been constructed or tested. With experimental measurements, the conductivity of press cake from carrot could have been obtained and specified with a more certain value. This would have strengthened the work leading to the design of the chamber, knowing that it is designed for the right

value of conductivity.

The simulations made in COMSOL are, of course, only simulations and differences from simulations and reality need to be accounted for. Other limitations in the work are the requirements stated by RISE and the requirements stated in the manual for the generator. Without the requirement of the distance between the electrodes to be 3 cm the resistance could have been increased by simply increasing the gap distance.

### 7.6 Improvements and Future Work

To achieve even more homogeneous electric field inside the treatment volume an insulator on top of the chamber in form of a lid could be used. With an insulator forming a lid on top of the test object the chamber would be symmetrical having the same structure both below and on top of the carrot tissue. This would increase the homogeneity of the field. In this project there was emphasis on avoiding air bubbles being formed in the test material. In future set-up, air bubbles might also be avoided e.g. by pressurizing the test material, preventing bubbles to form. In that case a lid could be used, optimizing the electric field a little bit further.

For future work the chamber will hopefully be built for the European project and be used for practical experiments. During the future project the chamber will be used to treat the press cake of carrot. During the process the needed level of electric field, lengths of pulses, and specific energy will be calibrated to fit the research. The optimal values that will be found are likely to differ from one case to another, depending on the purpose of the treatment and depending on what substance that should be extracted.

# 8

## Conclusion

In this chapter the conclusions made from this project is presented.

The main aim of this project was to design treatment chamber for the treatment of food. The chamber should meet some requirements as stated in the previous chapters.

All the three designs presented, design option 1 which is the easiest design to manufacture, and the most volume efficient does not meet the requirement of 95 % of the treatment volume being treated with the applied electric field, which is the most important requirement a chamber should meet. Therefore the design should not be considered in the future research project.

On the other hand comparing designs 2 and 3, which both have the same effective treatment volume of 96 %, design option 2 is the option suggested here to work further with. Design 2 is easier to construct than design 3, and it is also more volume efficient and is hence also the more economical option in terms of material usage.

For the pulse to be applied to the test chamber it can be concluded that no specific pulse characteristics can be selected as the most optimal set-up for the PEF treatment. This is because the pulse characteristics depends on the specific tissue being treated.

If a constant energy is wanted it can be achieved through several set-ups. If the applied voltage is for example lowered, the energy can be kept constant by either increasing the length of the pulses or by increasing the number of pulses. For the purpose of lowering the temperature increase, short pulses and low electric field should be applied.

The chamber can be used for other plant tissues, where the pulse characteristics might need to be changed for optimal treatment. By altering the geometry of the chamber the resistance could be increased,if need either by increasing the gap between the electrodes or by decreasing the contact area of the electrodes.





# Reference

- [1] M. E. Mohamed and A. H. A. Eissa, “Pulsed electric fields for food processing technology”, in *Structure and function of food engineering*, InTech, 2012.
- [2] V.-M. Humberto, O. Martin-Belloso, B.-L. Qin, F. J. Chang, M. M. Góngora-Nieto, G. V. Barbosa-Canovas, and B. G. Swanson, “Non-thermal food preservation: Pulsed electric fields”, *Trends in Food Science & Technology*, vol. 8, no. 5, pp. 151–157, 1997.
- [3] M. Dalvi-Isfahan, N. Hamdami, A. Le-Bail, and E. Xanthakis, “The principles of high voltage electric field and its application in food processing: A review”, *Food Research International*, vol. 89, pp. 48–62, 2016.
- [4] P. S. Brito, H. Canacsinh, and J. P. Mendes, “Comparison between monopolar and bipolar microsecond range pulsed electric fields in enhancement of apple juice extraction”, *IEEE Transactions on Plasma Science*, vol. 40, pp. 2348–2354, 10 Oct. 2012. DOI: [10.1109/TPS.2012.2209444](https://doi.org/10.1109/TPS.2012.2209444).
- [5] D. A. Eitelberg, J. van Vliet, and P. H. Verburg, “A review of global potentially available cropland estimates and their consequences for model-based assessments”, *Global Change Biology*, vol. 21, pp. 1236–1248, 2015. DOI: [10.1111/gcb.12733](https://doi.org/10.1111/gcb.12733).
- [6] C.-H. Lim, Y. Choi, M. Kim, S. W. Jeon, and W.-K. Lee, “Impact of deforestation on agro-environmental variables in cropland, north korea”, *Sustainability*, vol. 9, no. 8, 2017. DOI: <https://doi.org/10.3390/su9081354>.
- [7] D. C. Morton, R. S. DeFries, Y. E. Shimabukuro, L. O. Anderson, E. Arai, F. del Bon Espirito-Santo, R. Freitas, and J. Morissette, “Cropland expansion changes deforestation dynamics in the southern brazilian amazon”, *PNAS*, vol. 103, no. 39, pp. 14637–14641, 2006. DOI: <https://doi.org/10.1073/pnas.0606377103>.
- [8] T. Ponti, B. Rijk, and M. K. Ittersum, “The crop yield gap between organic and conventional agriculture”, *Agricultural Systems*, vol. 108, pp. 1–9, 2012. DOI: <https://doi.org/10.1016/j.agsy.2011.12.004>.
- [9] E. Vorobiev and N. Lebovka, “Enhanced extraction from solid foods and bio-suspensions by pulsed electrical energy”, *Food Engineering Reviews*, vol. 2, no. 2, pp. 95–108, 2010.
- [10] M. Micali, M. Fiorino, and S. Parisi, *The Chemistry of Thermal Food Processing Procedures*. Springer, Cham, 2016.
- [11] K. Nie, A. Micic-Vasovic, A. S. Henderson, M. Blank, R. Goodman, H. Tuncel, D. J. Panagopoulos, L. H. Margaritis, T. D. Xenos, I. N. Magras, M. A. Körpinar, and M. T. Kalkan, *Biological Effects of Electromagnetic Fields*. Springer, Berlin, Heidelberg, 2003, ch. Biological Effects of EMFs.

- [12] B. M. Novac, P. Sarkar, I. R. Smith, W. Whittow, and C. Greenwood, “An innovative and non-invasive technology for pef food processing”, *Pulsed Power Conference*, 2009. DOI: 10.1109/PPC.2009.5386214.
- [13] E. Puértolas, J. Raso, and G. Saldaña, *Pulsed Electric Field Treatment for Fruit and Vegetable Processing*. Springer International Publishing, 2016. DOI: 10.1007/978-3-319-26779-1\_181-1.
- [14] E. P. Spugnini and A. Baldi, *Electroporation in Laboratory and Clinical Investigations*. Nova Science Publishers, Inc., 2011.
- [15] C. Chen, S. Smye, M. Robinson, and J. Evans, “Membrane electroporation theories: A review”, *Medical and Biological Engineering and Computing*, vol. 44, pp. 5–14, 1-2 Mar. 2006. DOI: 10.1007/s11517-005-0020-2.
- [16] M. Sack and G. Müller, “Electrical design of electroporation reactors”, in *Optimization of Electrical and Electronic Equipment (OPTIM)*, 2010 12th International Conference on, IEEE, 2010, pp. 133–139. DOI: 10.1109/OPTIM.2010.5510560.
- [17] S. Mahnič-Kalamiza, E. Vorobiev, and D. Miklavčič, “Electroporation in food processing and biorefinery”, *The Journal of Membrane Biology*, vol. 247, pp. 1279–1304, 12 Dec. 2014. DOI: 10.1007/s00232-014-9737-x.
- [18] K. Huang and J. Wang, “Designs of pulsed electric fields treatment chambers for liquid foods pasteurization process: A review”, *Journal of Food Engineering*, vol. 95, no. 2, pp. 227–239, 2009.
- [19] F. D. Vito, “Application of pulsed electric field (pef) techniques in food processing”, PhD thesis, 2006. [Online]. Available: [https://www.google.se/url?sa=t&rct=j&q=&esrc=s&source=web&cd=2&cad=rja&uact=8&ved=2ahUKEwiEz8Tm2srZAhWrhKYKHeFoB3IQFjABegQIABA7&url=http%3A%2F%2Fwww.unisa.it%2Fsecure%2Fget%2Ffile%2F16.\\_tesi\\_francesca\\_de\\_vito.pdf%2Fid%2F1270&usq=A0vVaw35Z8RebKYVf5R-ubJeYQ2h](https://www.google.se/url?sa=t&rct=j&q=&esrc=s&source=web&cd=2&cad=rja&uact=8&ved=2ahUKEwiEz8Tm2srZAhWrhKYKHeFoB3IQFjABegQIABA7&url=http%3A%2F%2Fwww.unisa.it%2Fsecure%2Fget%2Ffile%2F16._tesi_francesca_de_vito.pdf%2Fid%2F1270&usq=A0vVaw35Z8RebKYVf5R-ubJeYQ2h).
- [20] M. Góngora-Nieto, D. Sepúlveda, P. Pedrow, G. Barbosa-Cánovas, and B. Swanson, “Food processing by pulsed electric fields: Treatment delivery, inactivation level, and regulatory aspects”, *LWT-Food Science and Technology*, vol. 35, no. 5, pp. 375–388, 2002.
- [21] J. Raso-Pueyo and V. Heinz, *Pulsed electric fields technology for the food industry: fundamentals and applications*. Springer Science & Business Media, 2010.
- [22] T. Kotnik, D. Miklavčič, and L. M. Mir, “Cell membrane electropermeabilization by symmetrical bipolar rectangular pulses: Part ii. reduced electrolytic contamination”, *Bioelectrochemistry*, vol. 54, no. 1, pp. 91–95, 2001.
- [23] T. Kotnik, L. M. Mir, K. Flisar, M. Puc, and D. Miklavčič, “Cell membrane electropermeabilization by symmetrical bipolar rectangular pulses: Part i. increased efficiency of permeabilization”, *Bioelectrochemistry*, vol. 54, no. 1, pp. 83–90, 2001.
- [24] F. Donsi, G. Ferrari, and G. Pataro, “Applications of pulsed electric field treatments for the enhancement of mass transfer from vegetable tissue”, *Food Engineering Reviews*, vol. 2, no. 2, pp. 109–130, 2010.
- [25] S. Asavasanti, W. Ristenpart, P. Stroeve, and D. M. Barrett, “Permeabilization of plant tissues by monopolar pulsed electric fields: Effect of frequency”,

- Journal of Food Science*, vol. 76, no. 1, E98–E111, 2011, ISSN: 1750-3841. DOI: 10.1111/j.1750-3841.2010.01940.x. [Online]. Available: <http://dx.doi.org/10.1111/j.1750-3841.2010.01940.x>.
- [26] C. Nordling and J. Österman, *Physics Handbook for science and engineering*. Newnes, 2006.
- [27] N. El Darra, N. Grimi, E. Vorobiev, N. Louka, and R. Maroun, “Extraction of polyphenols from red grape pomace assisted by pulsed ohmic heating”, *Food and Bioprocess Technology*, vol. 6, no. 5, pp. 1281–1289, 2013.
- [28] N. Grimi, N. I. Lebovka, E. Vorobiev, and J. Vaxelaire, “Effect of a pulsed electric field treatment on expression behavior and juice quality of chardonnay grape”, *Food Biophysics*, vol. 4, no. 3, pp. 191–198, 2009.
- [29] S. K. Sastry and S. Palaniappan, “Mathematical modeling and experimental studies on ohmic heating of liquid-particle mixtures in a static heater”, *Journal of Food Process Engineering*, vol. 15, no. 4, pp. 241–261, 1992.
- [30] K. Halden, A. De Alwis, and P. Fryer, “Changes in the electrical conductivity of foods during ohmic heating”, *International Journal of Food Science & Technology*, vol. 25, no. 1, pp. 9–25, 1990.
- [31] E. Vorobiev and N. Lebovka, *Electrotechnologies for extraction from food plants and biomaterials*. Springer, 2008, vol. 5996.
- [32] M. Sack and G. Mueller, “Scaled design of pef treatment reactors for electroporation-assisted extraction processes”, *Innovative Food Science Emerging Technologies*, vol. 37, no. Part C, pp. 400–406, Oct. 2016. DOI: <https://doi.org/10.1016/j.ifset.2016.09.005>.
- [33] O. Dietrich, A. Hubert, and S. Heiland, “Imaging cell size and permeability in biological tissue using the diffusion-time dependence of the apparent diffusion coefficient.”, *Physics in Medicine Biology*, vol. 59, no. 12, Jun. 2014. DOI: 10.1088/0031-9155/59/12/3081.
- [34] N. Lebovka, E. Vorobiev, and F. Chemat, *Enhancing Extraction Processes in the Food Industry*. CRC Press, 2016.
- [35] N. Lebovka, M. Bazhal, and E. Vorobiev, “Estimation of characteristic damage time of food materials in pulsed-electric fields”, *Journal of Food Engineering*, vol. 54, no. 4, pp. 337–346, 2002.
- [36] L. Barsotti, P. Merle, and J. C. Cheftel, “Food processing by pulsed electric fields. i. physical aspects”, *Food Reviews International*, vol. 15, pp. 163–180, 2 Nov. 2009. DOI: <https://doi.org/10.1080/87559129909541185>.
- [37] W.-C. WANG and S. K. SASTRY, “Changes in electrical conductivity of selected vegetables during multiple thermal treatments”, *Food process Engineering*, vol. 20, no. 6, pp. 499–516, 1997. DOI: <https://doi.org/10.1111/j.1745-4530.1997.tb00435.x>.
- [38] F. Marra, “Impact of freezing rate on electrical conductivity of produce”, *SpringerPlus*, vol. 2, p. 633, Nov. 2013.
- [39] M. Bazhal, N. Lebovka, and E. Vorobiev, “Optimisation of pulsed electric field strength for electroporation of vegetable tissues”, *Biosystems Engineering*, vol. 86, pp. 339–345, 3 Nov. 2003. DOI: 10.1016/S1537-5110(03)00139-9.

- [40] (). Ec/ph guide, [Online]. Available: [https://www.hydroponicsexpress.com.au/uploaded/files/client\\_added/EC-pH%20chart.pdf](https://www.hydroponicsexpress.com.au/uploaded/files/client_added/EC-pH%20chart.pdf) (visited on 03/21/2018).
- [41] H. Jaeger, M. Schulz, P. Lu, and D. Knorr, "Adjustment of milling, mash electroporation and pressing for the development of a pef assisted juice production in industrial scale", *Innovative Food Science and Emerging Technologies*, vol. 14, pp. 46–60, Apr. 2012. DOI: <https://doi.org/10.1016/j.ifset.2011.11.008>.
- [42] (). Water conductivity, [Online]. Available: <https://www.lenntech.com/applications/ultrapure/conductivity/water-conductivity.htm> (visited on 05/26/2018).
- [43] E. Kuffel, W. Zaengl, and J. Kuffel, *High Voltage Engineering Fundamentals (Second Edition)*. Elsevier Ltd, 2000.
- [44] M. Góngora-Nieto, P. Pedrow, B. Swanson, and G. Barbosa-Cánovas, "Impact of air bubbles in a dielectric liquid when subjected to high field strengths", *Innovative Food Science & Emerging Technologies*, vol. 4, no. 1, pp. 57–67, 2003.
- [45] B.-L. Qin, Q. Zhang, G. V. Barbosa-Canovas, B. G. Swanson, and P. D. Pedrow, "Inactivation of microorganisms by pulsed electric fields of different voltage waveforms", *IEEE Transactions on Dielectrics and Electrical Insulation*, vol. 1, no. 6, pp. 1047–1057, 1994.
- [46] G. V. Barbosa-Canovas, U. R. Pothakamury, M. M. Gongora-Nieto, and B. G. Swanson, *Preservation of foods with pulsed electric fields*. Academic Press, 1999.
- [47] S. Rodrigues and F. A. N. Fernandes, *Advances in fruit processing technologies*. CRC Press, 2012.
- [48] Z. Hong-Yan, W. De-Zhen, and W. Xiao-Gang, "Numerical studies of atmospheric pressure glow discharge controlled by a dielectric barrier between two coaxial electrodes", *Chinese Physics*, vol. 16, no. 4, p. 1089, 2007.
- [49] G. Donsi, G. Ferrari, and G. Pataro, "Inactivation kinetics of *saccharomyces cerevisiae* by pulsed electric fields in a batch treatment chamber: The effect of electric field unevenness and initial cell concentration", *Journal of food engineering*, vol. 78, no. 3, pp. 784–792, 2007.
- [50] J. Sun, "Fringe effect of electrical capacitance and resistance tomography sensors and its application in 3d imaging", 2014.
- [51] J. Sun and W. Yang, "Fringe effect of electrical capacitance and resistance tomography sensors", *Measurement Science and Technology*, vol. 24, no. 7, p. 074002, 2013.
- [52] (). Ieee recommended practices for safety in high-voltage high-power testing, [Online]. Available: <https://www.spellmanhv.com/-/media/en/Technical-Resources/Articles/IEEE-Recommended-Practices.pdf?la=en> (visited on 05/28/2018).
- [53] (). Dielectric strength of polymers, [Online]. Available: <http://polymerdatabase.com/polymer%20physics/Dielectric%20Strength.html> (visited on 05/28/2018).
- [54] (). Faraday cage, [Online]. Available: [https://en.wikipedia.org/wiki/Faraday\\_cage](https://en.wikipedia.org/wiki/Faraday_cage) (visited on 06/05/2018).

- 
- [55] S. Monga, R. Gorur, P. Hansen, and W. Massey, “Design optimization of high voltage bushing using electric field computations”, *IEEE Transactions on Dielectrics and electrical Insulation*, vol. 13, no. 6, 2006.
- [56] L. Jonsson and R. Johnansson, “High voltage bushings 100 years of technical advancement”, *ABB Review*, vol. 3, pp. 66–70, 2009.
- [57] (). Stainless steels - specifications, grades and properties, supplier data by aalco, [Online]. Available: <https://www.azom.com/article.aspx?ArticleID=2874> (visited on 05/22/2018).
- [58] (). The properties and advantages of ptfe, [Online]. Available: <https://www.fluorotec.com/blog/the-properties-and-advantages-of-polytetrafluoroethylene-ptfe/> (visited on 06/02/2018).
- [59] (). Polypropylene (pp) material properties, [Online]. Available: <http://www.goodfellow.com/E/Polypropylene.html> (visited on 05/21/2018).

