

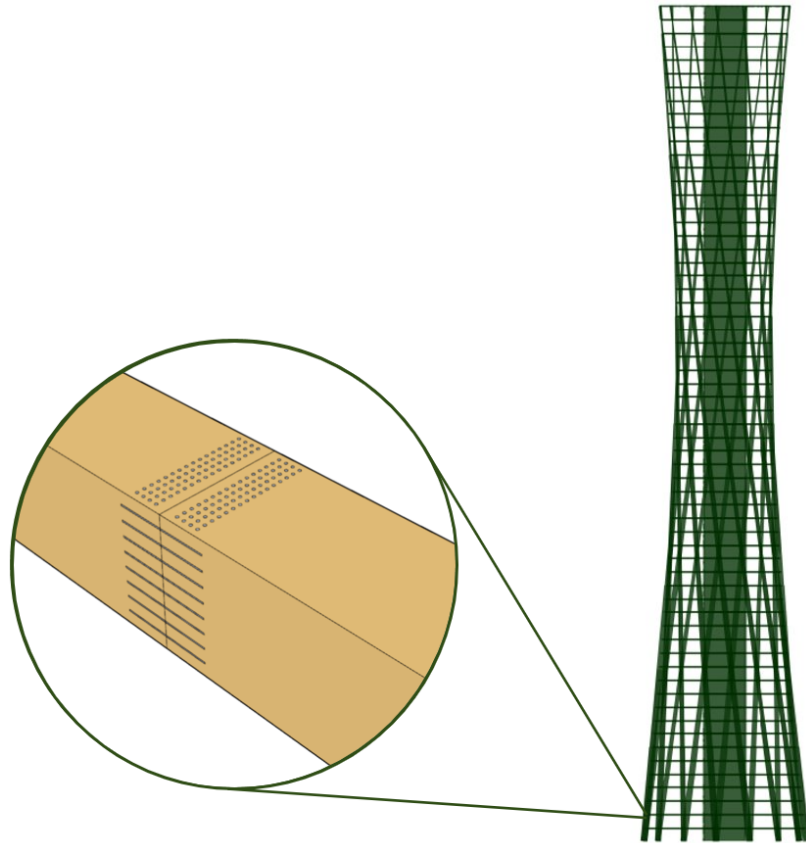

CHALMERS
UNIVERSITY OF TECHNOLOGY



The 200 m timber tower

A study of the connections in a tall timber structure

Master's thesis in Structural Engineering and Building Technology

ASTRID HEDEÅS

EMMA SKOGLUND

DEPARTMENT OF ARCHITECTURE AND CIVIL ENGINEERING

CHALMERS UNIVERSITY OF TECHNOLOGY

Gothenburg, Sweden 2022

www.chalmers.se

MASTER'S THESIS ACEX30

The 200 m timber tower

A study of the connections in a tall timber structure

ASTRID HEDEÅS
EMMA SKOGLUND



CHALMERS
UNIVERSITY OF TECHNOLOGY

Department of Architecture and Civil Engineering
Division of Structural Engineering
Research group for Lightweight Structures
CHALMERS UNIVERSITY OF TECHNOLOGY
Gothenburg, Sweden 2022

The 200 m timber tower
A study of the connections in a tall timber structure
ASTRID HEDEÅS
EMMA SKOGLUND

© ASTRID HEDEÅS & EMMA SKOGLUND, 2022.

Supervisors: Felicia Flink & Christopher Halldén, VBK
Examiner: Robert Jockwer, Chalmers University of Technology

Master's Thesis 2022
Department of Architecture and Civil Engineering
Division of Structural Engineering
Research group for Lightweight Structures
Chalmers University of Technology
SE-412 96 Gothenburg
Telephone +46 31 772 1000

Cover: Two timber beams in the 200 m timber tower connected with a slotted-in steel plate connection.

Typeset in L^AT_EX
Printed by Chalmers Reproservice
Gothenburg, Sweden 2022

The 200 m timber tower
A study of the connections in a tall timber structure
ASTRID HEDEÅS
EMMA SKOGLUND
Department of Architecture and Civil Engineering
Chalmers University of Technology

Abstract

Building tall has been a rising trend the latest years and the use of timber for tall structures is considerably increasing. With new construction methods, new challenges arises and timber has both advantages and disadvantages compared to other common building materials. One of the large challenges when constructing tall timber buildings is the connections between the load-bearing elements.

In this thesis, different types of timber connection designs were studied to see the structural behaviour in terms of load-bearing capacity in the ultimate limit state. The study was executed for the most critical joint that was located in the bottom of the 200 m tall timber building, where the largest normal force appeared. The slotted-in steel plate connection was chosen for further investigation of connection stiffness by performing FE-analyses.

Furthermore, a study of how the stiffness was affected by different parameters have been conducted. The analysed parameters were the number of dowels, the dowel dimensions, the number of slotted-in steel plates, the steel plate thicknesses and the distances between the steel plates. The results show that the parameter with the largest impact on the stiffness was the number of steel plates where an increased amount of plates lead to a larger stiffness. The dowel dimension and the number of dowels are dependent on each other and both these parameters had a slightly smaller influence on the stiffness compared to the number of plates. It was determined that a combination of a small dimension and a large amount of dowels gave a larger stiffness. Two parameters that appeared to have small effect on the global stiffness were the thickness of the steel plates and the distance between them.

Based on the stiffness investigation, eight new and improved connection proposals were designed and analysed. In order to identify the most optimized alternative the connections were graded with the help of a weighting matrix. The connection with the highest weighted grade was analysed in terms of deflection in the serviceability limit state to make sure that the requirement was fulfilled. The highest graded connection was chosen as the final design proposal for the connections in the 200 m timber tower.

Keywords: Deformation, Displacement, Failure modes, Slotted-in steel plates, Stiffness, Tall timber structure, Timber, Timber connection.

Acknowledgements

This thesis contains a study of the connections in the 200 m timber tower. The connection stiffness and deformation of the building have been analysed. The work has been conducted during the spring term of 2022. The project was carried out by initiation of VBK as a collaboration between the Lightweight Structures group at the Division of Structural Engineering at Chalmers University of Technology and VBK.

The work started off at home by reason of the covid-19 pandemic but due to lightened restrictions the work continued at VBK's office from beginning of February and forward. Computers and the needed softwares were provided by VBK during the whole project.

We want to give a special thank to our supervisors at VBK, Felicia Flink and Christopher Halldén, that have been very supportive and helpful during the work with this thesis. We also want to thank our examiner Robert Jockwer at Chalmers for his guidance and expertise during the project.

Astrid Hedeås & Emma Skoglund

Gothenburg, June 2022

List of Acronyms

Below is the list of acronyms that have been used throughout this thesis listed in alphabetical order:

CLT	Cross Laminated Timber
EWP	Engineered Wood Products
Glulam	Glued Laminated Timber
LTRs	Long Threaded Rods
LVL	Laminated Veneer Lumber
SLS	Serviceability Limit State
SSP	Stressed Skin Panels
ULS	Ultimate Limit State

Nomenclature

Below is the nomenclature of parameters and variables that have been used throughout this thesis.

Latin upper case letters

A	Area
$A_{net,t}$	Net cross-sectional area perpendicular to the grains
$A_{net,v}$	Net shear area parallel to the grains
F	Force
$F_{ax,Ed}$	Design value of withdrawal action
$F_{ax,Rd}$	Design value of withdrawal capacity
$F_{ax,Rk}$	Characteristic value of withdrawal capacity
$F_{ax,\alpha,Rk}$	Characteristic withdrawal capacity at an angle to the grains
$F_{bs,Rk}$	Characteristic value of block shear failure capacity
$F_{v,Ed}$	Design value of shear action
$F_{v,Rd}$	Design value of shear capacity
$F_{v,Rk}$	Characteristic value of shear capacity
K_{ser}	Slip modulus for one fastener in serviceability limit state
K_{tot}	Total slip modulus for a whole connection
K_u	Slip modulus for one fastener in ultimate limit state
$M_{y,Rk}$	Characteristic value of yield moment
$R_{ax,k}$	Characteristic value of withdrawal capacity
R_k	Characteristic value of load-bearing capacity
$R_{t,k}$	Characteristic value of load-bearing capacity in tension
U_{block}	Utilization ratio with regard to block shear failure
$U_{fastener}$	Utilization ratio with regard to failure of fastener

Latin lower case letters

a_1	Distance between fasteners parallel to the grains
a_2	Distance between fasteners perpendicular to the grains
a_3	Distance from fastener to end of beam
a_4	Distance from fastener to edge of beam
a_{\parallel}	Distance between fasteners parallel to the grains
a_{\perp}	Distance between fasteners perpendicular to the grains
d	Diameter of fastener
$f_{ax,k}$	Characteristic value of pointside withdrawal strength
$f_{c,0,k}$	Characteristic value of compressive strength parallel to the grains
$f_{c,90,k}$	Characteristic value of compressive strength perpendicular to the grains
f_h	Embedment strength
$f_{h,0,k}$	Characteristic value of embedment strength parallel to the grains
$f_{h,i,k}$	Characteristic value of embedment strength of member i
$f_{h,\alpha,k}$	Characteristic value of embedment strength with an angle to the grains
$f_{head,k}$	Characteristic value of headside pull-through strength
f_m,k	Characteristic value of bending strength
$f_{t,0,k}$	Characteristic value of tensile strength parallel to the grains
$f_{t,90,k}$	Characteristic value of tensile strength perpendicular to the grains
f_u	Characteristic value of tensile strength for fasteners
f_v,k	Characteristic value of shear strength
g	Permanent load
h	Height of the specimen
k	Stiffness
k_d	Dimension factor for panel
k_{ef}	Reduction factor for the effective number of fasteners
k_{mod}	Modification factor taking the effect on strength parameters of the duration of load and service class into account
k_1	Reduction factor for shear strength
k_{90}	Factor for calculating the characteristic embedment strength at an angle to the grain
l_{ef}	Effective embedment length

l_i	Length of glued-in part of rod
l_p	Length of the steel plate
n	Number of fasteners
n_b	Number of fasteners along the width of the plate
n_{ef}	Effective number of fasteners
n_l	Number of fasteners along the length of the plate
n_p	Number of plates
q	Variable load
q_k	Characteristic value of variable load
q_d	Design value of variable load
t	Thickness of specimen
t_{pen}	Penetration depth or length of threaded part
t_1	Distance between the edge of the beam and the first steel plate
t_2	Distance between the steel plates
u	Maximum horizontal displacement of the structure

Greek lower case letters

α	Angle
β	Ratio between the characteristic embedment strengths if two different members
γ	Angle between rod and grain
γ_M	Partial factor for material
κ_1	Factor that takes the climate class in account for calculations of load-bearing capacity for rods
ρ_k	Characteristic timber density
ρ_m	Mean timber density



Contents

List of Acronyms	ix
Nomenclature	xi
List of Figures	xix
List of Tables	xxi
1 Introduction	1
1.1 Background	1
1.2 Aim	2
1.3 Method	2
1.4 Limitations	3
2 Theoretical framework	5
2.1 Timber as structural material	5
2.1.1 Hardwood and softwood	6
2.1.2 Moisture	6
2.1.3 Temperature	6
2.1.4 Creep deformations	6
2.1.5 Environmental impact	7
2.2 Different types of timber	8
2.2.1 Sawn timber	8
2.2.2 Glued laminated timber	8
2.2.3 Cross-laminated timber	9
2.2.4 Laminated veneer lumber	10
2.3 Loads on tall buildings	10
2.3.1 Permanent loads	10
2.3.2 Imposed loads	10
2.3.3 Wind loads	11
2.3.4 Ultimate limit state, ULS	11
2.3.5 Serviceability limit state, SLS	11
2.4 Timber connections	11
2.4.1 Nails	11
2.4.2 Staples	12
2.4.3 Dowels	12
2.4.4 Bolts	12

2.4.5	Screws	13
2.4.6	Steel rods	13
2.4.7	Carpentry joints	14
2.4.8	Steel plates	15
2.5	Connections in other tall timber buildings	16
2.5.1	Mjøstårnet, Norway	16
2.5.2	Treet, Norway	17
2.5.3	Sara Cultural Centre, Sweden	17
2.5.4	HoHo, Austria	17
2.5.5	Brock Commons Tallwood House, Canada	17
2.6	Design of connections	17
2.6.1	Design value	18
2.6.2	Dowel action	18
2.6.3	Embedment strength	18
2.6.4	Yield moment	20
2.6.5	Axial load	21
2.6.6	Block shear failure	22
2.6.7	Failure modes timber-to-timber connections	23
2.6.8	Failure modes steel to timber connections	26
2.6.9	Capacity for glued-in rods	31
2.6.10	Capacity for long threaded rods	31
2.6.11	Deformation	32
2.6.12	Minimum distances	33
2.6.13	Effective number of fasteners	35
2.6.14	Combined loads	36
2.6.15	Stiffness	36
2.7	Robustness	37
3	Previous studies	39
3.1	Geometry	39
3.2	Dimensions	40
3.3	Displacements	40
4	Method	41
4.1	Normal forces	41
4.2	Design of connections, hand calculation	41
4.3	Analysis of connection stiffnesses	46
4.4	Optimization of connections	48
5	Connection analyses and results	51
5.1	Forces	51
5.2	Connection type	51
5.2.1	External plates	52
5.2.2	Rods	53
5.2.3	Slotted-in steel plate	54
5.2.4	Chosen connection type	57
5.3	Connection stiffness and displacement	57

5.4	Verification of stiffness	57
5.5	Effect on stiffness	58
5.5.1	Effect of changing stiffness	58
5.5.2	Effect of number of dowels	60
5.5.3	Effect of dowel dimension	62
5.5.4	Effect of number of steel plates	64
5.5.5	Effect of steel plate thickness	66
5.5.6	Effect of distance between steel plates	68
5.5.7	Important parameters to reach high stiffness in connections . .	70
5.6	Redesigned connections	71
5.7	Evaluation	73
5.7.1	Weighting matrix	74
5.7.2	Grading matrix	76
5.7.3	Amount of steel	76
5.7.4	Analysis in SLS	77
5.8	The final connection	79
6	Discussion	81
6.1	Connection design	81
6.2	Stiffness analysis	82
6.3	Final connection	83
6.4	Improvements and future studies	85
7	Conclusion	87
	Bibliography	88
A	Appendix	I
A.1	Hand calculations for a connection with slotted-in steel plates	II
A.2	Hand calculations for connection with external steel plates	XII
A.3	Hand calculations for connection with external timber plates	XVIII
A.4	Hand calculations for connection with glued-in rods	XXV
A.5	FEM-design code	XXIX

List of Figures

2.1	The grain directions in wood.	5
2.2	Effect of creep over time (Swedish Wood, 2016a).	7
2.3	Glued laminated timber with several lamellas glued together (Swedish Wood, 2016c).	8
2.4	Cross-laminated timber (Swedish Wood, 2016a).	9
2.5	Part of a laminated veneer lumber board (Swedish Wood, 2016a). . .	10
2.6	Round smooth nail (Swedish Wood, 2016a).	12
2.7	Dowel (Swedish Wood, 2016a).	12
2.8	Bolt with and without washer and nut (Swedish Wood, 2016a). . . .	13
2.9	Screws (Swedish Wood, 2016a).	13
2.10	Glued-in rods (Swedish Wood, 2016d).	14
2.11	Contact joint with supplementary fasteners (Swedish Wood, 2016a). .	15
2.12	Slotted-in steel plates (Swedish Wood, 2016d).	16
2.13	External steel plate (Swedish Wood, 2016d).	16
2.14	Dowel action (Swedish Wood, 2016a).	18
2.15	Predrilling, embedment strength (Swedish Wood, 2016a).	19
2.16	Block shear failure (Swedish Wood, 2016a).	23
2.17	Failure mode I (Swedish Wood, 2016a).	24
2.18	Failure mode II (Swedish Wood, 2016a).	25
2.19	Failure mode III (Swedish Wood, 2016a).	25
2.20	Failure modes double shear (Swedish Wood, 2016a).	26
2.21	Failure mode to Equation 2.30 (Swedish Wood, 2016a).	27
2.22	Failure mode to Equation 2.31 (Swedish Wood, 2016a).	27
2.23	Failure mode to Equation 2.32 (Swedish Wood, 2016a).	28
2.24	Minimum distances between fasteners a_1 , a_2 , a_3 and a_4	34
2.25	Minimum distances t_1 and t_2 (Swedish Wood, 2016d).	34
2.26	Minimum distances glued-in rods (Swedish Wood, 2016d).	35
3.1	The hyperboloid structure.	39
4.1	Slotted-in steel plate connection with the length and width of the plate explained.	44
4.2	Example if a connection modelled in FEM-design.	47
5.1	Connections A-E.	56
5.2	Displacement changes with varying stiffness.	59
5.3	Change of stiffness with varying number of dowels.	61

5.4	Change of stiffness with varying dowel dimensions.	63
5.5	Change of stiffness with varying number of plates.	66
5.6	Change of stiffness with varying plate thickness.	68
5.7	Change of stiffness with varying distance between plates.	70
5.8	The weighting matrix.	75
5.9	The grading matrix.	76
5.10	The steel amount was compared for 1.5 m of the beam.	77
5.11	Design of the final connection.	79
6.1	Example of a slotted-in steel joint with several connecting beams (Crocetti, 2016).	86

List of Tables

2.1	Characteristic strengths for structural timber C30 in MPa.	6
2.2	Minimum distances end/edge and spacing for bolts, in mm (Swedish Wood, 2016b).	33
2.3	Minimum distances end/edge and spacing for dowels, in mm (Swedish Wood, 2016b).	33
3.1	Truss and beam dimensions for the different floors.	40
3.2	Maximum horizontal displacements in SLS.	40
5.1	Truss dimensions and maximum normal forces for the different floors.	51
5.2	Properties of connections with external steel plates.	52
5.3	Properties of connections with external timber plates.	53
5.4	Properties of glued-in rod connections.	53
5.5	Properties of slotted-in steel plate connections A-E.	55
5.6	Stiffness and displacement for connections A-E.	57
5.7	Verification of stiffness for connection A.	58
5.8	Effect of changing the total stiffness of the connection. The initial values for connection C are marked with bold text.	59
5.9	Properties of connections with varying amount of dowels.	60
5.10	Stiffness and displacement for connections with varying amount of dowels.	61
5.11	Properties of connections with varying dowel dimensions.	62
5.12	Stiffness and displacement for connections with varying dowel dimensions.	63
5.13	Properties of connections with varying amount of plates.	64
5.14	Stiffness and displacement for connections with varying amount of plates.	65
5.15	Properties of connections with varying plate thickness.	67
5.16	Stiffness and displacement for connections with varying plate thickness.	67
5.17	Properties of connections with varying distance between plates. . . .	69
5.18	Stiffness and displacement for connections with varying distance between plates.	69
5.19	Properties of connections F-M.	72
5.20	Stiffness and displacement for connections F-M.	73
5.21	Amount of steel for connections F-M.	77
5.22	Stiffness and displacement for connection M in SLS.	77
5.23	Properties of the final connection.	79

1

Introduction

Building tall has been a rising trend the latest years, most often in concrete or steel, because of their structural properties, but they also have an apparent drawback, the environmental impact can often be relatively large. Due to the arising environmental issues better solutions are widely sought and therefore the amount of wood used, for both lower and taller structures, is considerably increasing. With new construction methods new challenges arises and timber has both advantages and disadvantages compared to other common building materials. As a consequence of this development more research about timber structures is needed and one of the large challenges when constructing tall timber buildings is the connections between the load-bearing elements.

1.1 Background

There is a long history of using timber as a building material, despite this it is today considered as an innovative way of building. Smaller houses have been constructed of timber for ages, but taller buildings have not been that common. Until the middle of the 1990s timber buildings taller than two floors were not allowed in Sweden (Swedish Wood, n.d.). Since then, the development has rapidly increased and today 15 % of the newly built apartment houses are constructed of timber, however there are not that many tall ones. According to CTBUH (2022) there are several categories defining a tall building but simplified it is described as 50 metres or taller. The tallest standing building made of timber is Mjøstornet in Norway with a height of 85 metres, a large difference compared to the world's tallest building Burj Khalifa with its 828 metres, almost ten times taller.

The majority of the global population lives in cities and the number is expected to increase in the nearby future (Xi et al., 2021). As cities are expanding rapidly there is a need of effective land use and an efficient way to use land is to construct tall buildings. Since the building sector is responsible for a large amount of global carbon emissions, sustainable building material and building processes are important (Dangel, 2021). Therefore, tall timber constructions are of high interest when planning for urbanised cities and needs to be thoroughly investigated.

Even though timber has many benefits there are also some structural challenges when designing and constructing tall timber buildings. Tall light-weight structures tend to be sensitive to wind loads and consequences like large horizontal movements can be difficult to evade (Taranath, 2012). Buildings should not only be designed

to fulfill the required load-bearing capacity but also to make sure that the environment is comfortable for people to stay in (Johansson et al., 2015). Therefore the limits for vibrations, springiness of floors and sway are important to consider. One component of the structure that affects these factors a lot is the connections between the load-carrying elements. It is therefore a critical point that closely have to be studied, especially in tall buildings. This topic will be further investigated in this thesis to see what type of connections that are suitable for large sized timber elements in a tall timber building.

1.2 Aim

This thesis will be the third part of the 200 m Timber Tower project, and the aim will involve the design of the connections based on the results from previous studies of the building. Furthermore, the aim is to investigate how the design of the connections impacts the structural behaviour on a global level in terms of load-carrying capacity, stiffness and deformations.

1.3 Method

The method of this project will include the following steps:

1. **Literature study**

Study of the previous parts of the project as well as theory and norms of wood as structural material, loads on tall buildings, timber connections, other tall timber buildings and the design process of timber connections.

2. **Previous models**

Study models of the proposed building made in previous investigations and find the maximum axial forces to be used for further calculations. Identify critical joints and their location.

3. **Connections**

Investigate different design suggestions for connections and perform preliminary designs of some proposals for the timber connections based on hand calculations.

4. **Displacement of joints**

Check of connection behaviour with regard to stiffness and displacement in the computer program FEM-design.

5. **Global stiffness**

Finite element study of the connections in Karamba3D to find the global stiffness and displacement of the building.

6. **Optimization**

Evaluation of which design parameters that has the largest influence on the global stiffness.

7. **Final design**

Compose a final design of the proposed connections based on the results from the study.

8. Conclusion

Make a conclusion of the connections impact on the structural behaviour of the building.

1.4 Limitations

The limitations set up for this study are:

- Fatigue in the connections will not be considered as the main focus and therefore not included in the calculations in this report.
- The connections will be designed with regard to axial force and will therefore be assumed to not take any moments.
- Calculations will not be performed for all connections in the building, the focus will be on the critical ones. Only connections for the largest truss dimension will be accounted for.
- Fire safety will not be regarded.

2

Theoretical framework

This section consists of general information needed to understand the further investigations. It includes the most essential information about the material wood, different timber connections and the design procedures of connections.

2.1 Timber as structural material

Timber is an anisotropic material which means that it has different material properties in different directions (Swedish Wood, 2016a). It is therefore important to be aware of the fiber direction when using timber for structural purposes. The three fiber directions are often called longitudinal, tangential and radial, for illustration of the directions see Figure 2.1. Different material properties, such as Young's modulus and Poisson's ratio, are defined for the different directions due to the varying strength.

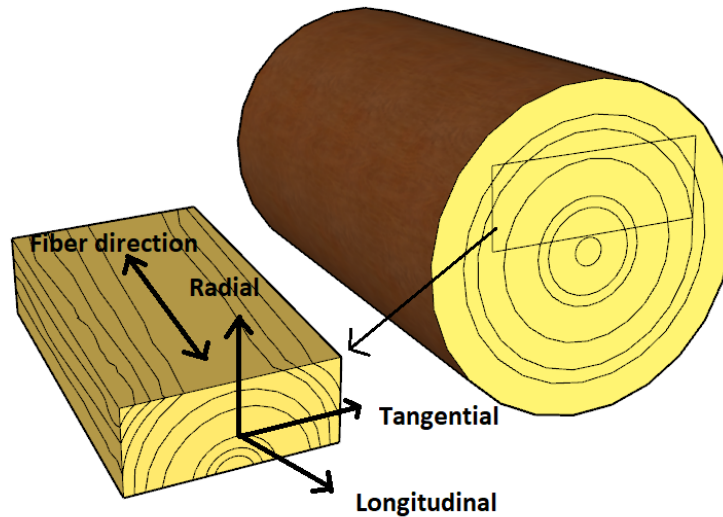

Figure 2.1: The grain directions in wood.

Timber is generally stronger parallel to the grains compared to the perpendicular direction but the strength is also dependent on the load, if it is tensile or compressive. An example of this is shown in Table 2.1 where the characteristic strengths in the

different directions for the structural timber class C30 are listed. These values clearly shows the considerable differences in strength for the different directions. The strongest direction is compression parallel to the grains and the weakest is tension perpendicular to the grains.

Table 2.1: Characteristic strengths for structural timber C30 in MPa.

$f_{t,0}$	$f_{t,90}$	$f_{c,0}$	$f_{c,90}$
19	0.4	24	2.7

2.1.1 Hardwood and softwood

There are two main groups of wood materials, hardwood produced from deciduous trees and softwood from conifers (Blaß and Sandhaas, 2017). Hardwood has an overall higher strength and density than softwood. Despite this, softwoods, especially fir and spruce, are more frequently used for structural purposes. One of the main reasons for this is that softwoods grow much faster than hardwoods and therefore softwood is commonly cheaper (Arnold Laver, 2022). Softwood is also easier and more forgiving to work with as it is softer. Although, in some situations hardwood is used in specific critical details to increase the capacity or the stiffness, for example a part of a cross-section can be exchanged for a part made of hardwood. It can also be used for some kinds of timber fasteners, creating a denser and stiffer connection.

2.1.2 Moisture

Wood is very sensitive to moisture and the amount of moisture in the wood is dependent on the relative humidity in the surrounding air (Swedish Wood, 2016a). Many of the structural properties of wood is strongly dependent on the moisture content. With large amounts of moisture a larger risk of creep deformations appear and both the stiffness and the strength of the wood decreases (Blaß and Sandhaas, 2017). Another effect that significantly increases with increased moisture is fungal decay which can lead to loss of wood strength.

2.1.3 Temperature

With increased surrounding temperature the strength and stiffness of wood is decreased (Swedish Wood, 2016a). At temperatures between -30 °C and 90 °C the effects of temperature changes on wood are small, but at temperatures above 95 °C the effects becomes larger. Since the changes usually occur under high surrounding temperatures the temperature effects are most often not included in the design of timber structures.

2.1.4 Creep deformations

Creep is a type of deformation that increases with time and is therefore highly important to consider when designing timber structures (Blaß and Sandhaas, 2017). When creep first appears the instantaneous deformation is large, the deformation

keeps increasing over time but not in the same pace as in the beginning, see Figure 2.2. If the load is removed the deformation can disappear and return to the initial value but most often a smaller deformation becomes permanent.

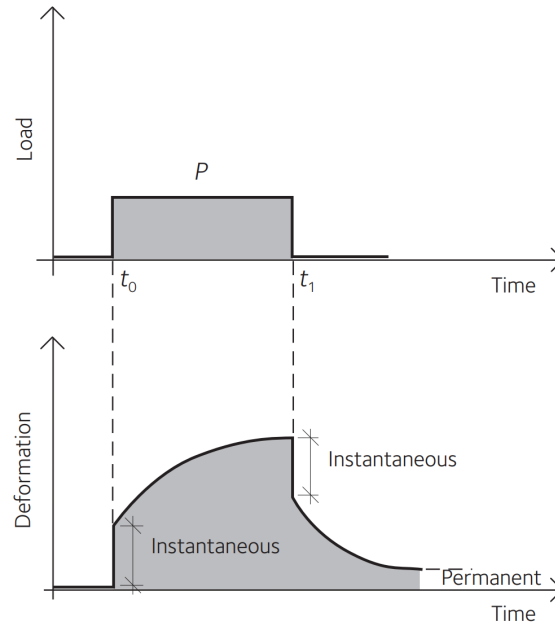

Figure 2.2: Effect of creep over time (Swedish Wood, 2016a).

How much creep that appears in a structure is dependent on moisture content, load duration, temperature and stress level. Creep is also dependent on the material and some wood products are exposed to creep in a larger extent than others. When accounting for creep in calculations it is done by adding the creep contribution to the total deformations.

2.1.5 Environmental impact

Today's society is facing major environmental challenges. When it comes to consumption of energy and natural resources the construction sector is one of the largest users (Zubizarreta et al., 2019). The use of structural materials is one of the contributing factors. Timber has clear benefits when it comes to environmental impact compared to other building materials such as concrete and steel. Timber is renewable and can often be produced locally which results in shorter transports. It is also regarded as a CO₂ neutral building material as wood absorbs CO₂ from the surroundings (Blaß and Sandhaas, 2017). This, in combination with the ongoing urbanisation, makes tall timber buildings a very good alternative towards more functional cities and a sustainable future.

2.2 Different types of timber

The available dimensions of regular sawn timber are limited by the size of trees, the maximum size produced in Sweden is 245 mm deep and 5500 mm long (Swedish Wood, 2016a). If a larger beam is required several smaller boards can be assembled with an adhesive to reach the desired dimensions, such products are called engineered wood products, EWP. Other benefits of creating new timber materials are better material properties than regular sawn timber, increased strength, less variations in the material and that waste material can be made use of.

2.2.1 Sawn timber

By sawing logs large structural members are produced (Swedish Wood, 2016a). The wood is then processed in a few steps before it can be used for constructions. Solid timber is divided into different strength classes from C14 up to D70, where the letter determines if it is softwood (C) or hardwood (D) and the number determines the bending strength $f_{m,k}$ in MPa.

As mentioned, the dimensions of sawn timber are not always sufficient enough, if so, other types of wood products can be used. For tall timber buildings large structural components are often required and therefore other wood products are more frequently used.

2.2.2 Glued laminated timber

One of the earliest EWPs on the market was glued laminated timber, glulam, that consists of lamellas glued together parallel to the grains creating a beam (Swedish Wood, 2016a), see Figure 2.3. When adhesive is distributed over the entire surface of the lamellas the connection is considered as rigid. One of the benefits with glulam and other EWPs is that weaknesses such as knots, piths or cracks in the wood are less prominent when several layers of the material are combined (Blaß and Sandhaas, 2017).

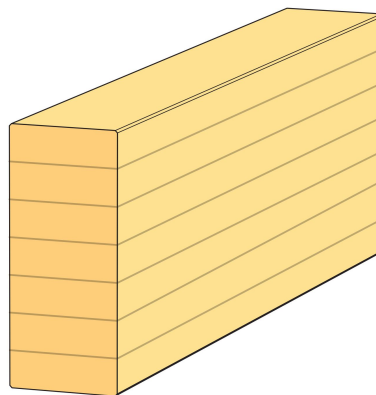

Figure 2.3: Glued laminated timber with several lamellas glued together (Swedish Wood, 2016c).

There are two types of glulam classes, homogeneous and combined (Swedish Wood, 2016a). When all the lamellas in the beam are of the same timber strength it is a homogeneous glulam beam. For a combined glulam beam a stronger timber class is used for the outer lamellas while the inner lamellas consists of weaker timber. The most common lamella thickness for Swedish glulam is 45 mm and glulam beams are produced with a width up to 215 mm. If a wider beam is required several glulam beams can be glued together to reach the desired width. The glulam strength classes are, just as the sawn timber, defined by their bending strength. For example, GL30h is a material of homogeneous glulam with $f_{m,k} = 30$ MPa. GL30c has the same bending strength but is made of combined glulam.

Glulam beams can be used for different purposes in a structure but they are especially sufficient for carrying bending stresses. In bending the largest compressive and tensile stresses occurs in the top and bottom lamellas and this is the purpose of producing combined glulam beams, with different timber strength classes in different lamella layers.

2.2.3 Cross-laminated timber

A newer innovation within the timber industry that considerably has increased in use the latest two decades is cross-laminated timber, CLT (Swedish Wood, 2016a). It is constructed by sawn timber glued together in layers with the grains perpendicular to the direction of the grains in the previous layer, see Figure 2.4. The number of layers varies depending on the area of use, but it is always an odd number since a better strength is reached when the grains of the outer layers are oriented in the same direction.

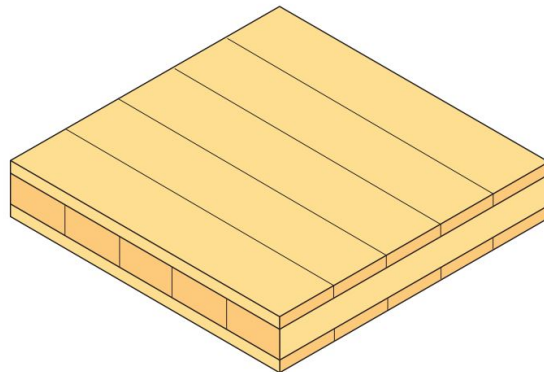

Figure 2.4: Cross-laminated timber (Swedish Wood, 2016a).

The structure of CLT makes it strong in both directions and suitable for carrying loads both parallel and perpendicular to the grains of the outer layers (Blaß and Sandhaas, 2017). Cross-laminated timber is often used for prefabricated structures such as walls or floors since it is easy to have them produced with insulation, windows and other building elements in the right place from the factory. Thus, transporting them to the building site and directly have them mounted in place becomes very time efficient.

2.2.4 Laminated veneer lumber

Veneers are 2-4 mm thin layers of wood and by gluing them together different types of EWPs can be created. One of the most common ones is showed in Figure 2.5 and it is called laminated veneer lumber, LVL, where the veneers create panels with dimensions up to 3x24 m (Swedish Wood, 2016a). With a thickness of 20-90 mm the LVL attains high reliability as well as low variability due to the distribution of the wood defects. The veneers are most often oriented with the same fiber direction for all the panels but the direction can also be varied between the different layers.

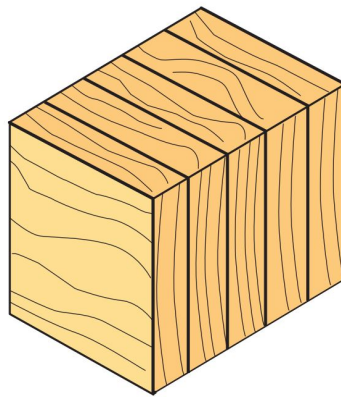

Figure 2.5: Part of a laminated veneer lumber board (Swedish Wood, 2016a).

2.3 Loads on tall buildings

There are specific rules to follow when applying loads during the design of a structure. Which loads to account for and the size of them are dependent on many things, for example the type of structure, the shape of it, what it will be used for and where it is geographically located. In this chapter the loads and load combinations that are relevant for tall timber structures are shortly described.

2.3.1 Permanent loads

The self-weight of the structure is considered as a permanent load (Swedish Institute of Standards (SIS), 2003). The weight of all structural parts are included in the self-weight. Timber is a light-weight material and therefore has a lower self-weight than for example concrete but due to the size of this building the structural members will have large dimensions and hence also a larger self-weight.

2.3.2 Imposed loads

The imposed loads include the temporary or changeable loads in the building, for example furniture and people (Al-Emrani et al., 2013). There are standard values for imposed loads that are defined depending on the type of building. They are most often defined per square metre of the floor area of the building.

2.3.3 Wind loads

For tall buildings the wind loads most often is one of the largest challenges to handle. The taller the building, the larger the loads become. Large horizontal loads can lead to horizontal movements of the structure which can cause discomfort of the residents (Swedish Institute of Standards (SIS), 2003). The wind load is most often considered as a variable and distributed load.

2.3.4 Ultimate limit state, ULS

The ultimate limit state is the state when the structure is on the exact limit of collapse (Al-Emrani et al., 2013). This load case is often used for design of load-bearing components. The different loads that the structure is subjected to are multiplied with safety factors depending on the type of load. The design load is calculated according to Equations 6.10a and 6.10b in SS-EN 1990 (Swedish Institute of Standards (SIS), 2002).

2.3.5 Serviceability limit state, SLS

If the serviceability limit state is exceeded the structure will lose its function, it will not longer fulfill the conditions it should during usage (Al-Emrani et al., 2013). The serviceability criteria includes the function of the load-bearing elements at normal use, the comfort of the people in the building as well as the aesthetics of the building. There are several load combinations used in SLS and these can be found in Section 6.5.3 in SS-EN 1990 (Swedish Institute of Standards (SIS), 2002).

2.4 Timber connections

The suitable connection is an important part in design of timber construction, especially considering the fact that connections in timber structures often are weaker than the connecting structural members (Blaß and Sandhaas, 2017). In the following chapter, some of the most commonly used connection types in timber structures are described.

2.4.1 Nails

A nail is a dowel type fastener which is commonly used in trusses and diaphragms (Blaß and Sandhaas, 2017). This fastener is one of the most used fastener in timber structures and therefore offered in many forms and sizes. Round smooth shank tail nails, see Figure 2.6, and nails with squared cross-section are most frequently used. Nails are offered in standardised dimensions in a range between 2-8 mm in diameter and 40-200 mm in length. In order to avoid timber splitting, predrilling of holes can be used and this will also help the nails to penetrate timber with high density. A joint of nails consists of a minimum of two nails.



Figure 2.6: Round smooth nail (Swedish Wood, 2016a).

If timber has a density larger than $500\text{kg}/\text{m}^3$ or the nail has a diameter larger than 6 mm, predrilling is necessary. The embedment strength increases with predrilling which means that the capacity when the nails is laterally loaded increases. The need for spacing between nails and to the edge decreases with predrilling which can enable for a more solid joint.

2.4.2 Staples

Staples resembles nails in a load-bearing way, although the quality of the steel is often higher for staples than for nails (Blaß and Sandhaas, 2017). This means that the yield moment is higher for staples. Another aspect to consider while using staples is the angle between the staple crown and the grain direction of the wood. It can be estimated that one staple is equal to two nails with the same diameter if the angle between the crown and grain is minimum 30° . The load-bearing capacity of the joint is 70 % lower if the angle is below 30° .

2.4.3 Dowels

A dowel is a steel fastener with cylindrical shape, often smooth although in some cases rugged (Swedish Wood, 2016a), see Figure 2.7. Dowels have a round cross-section and do not have a head in comparison with, for example, nails. Dowels are offered in diameters between 6-30 mm. Dowels are simple to arrange although predrilling is necessary (Blaß and Sandhaas, 2017).



Figure 2.7: Dowel (Swedish Wood, 2016a).

2.4.4 Bolts

Bolts resemble dowels although this kind of connection involves a head and often a nut to establish a tight connection (Swedish Wood, 2016a), see Figure 2.8. The material is most commonly steel and the shank is smooth near the head and threaded in the end where the nut is fastened (Blaß and Sandhaas, 2017). Furthermore, bolts normally have washers between the nut/head and the wood. The diameter of the washer should be three times the diameter of the bolt and should have full contact with the timber. Bolts sometimes requires retightening if the moisture content changes.

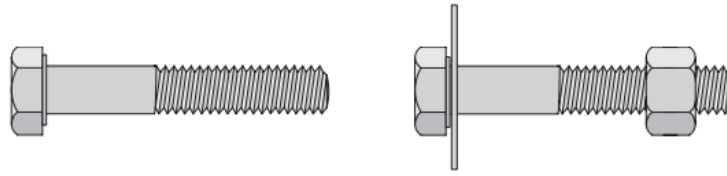

Figure 2.8: Bolt with and without washer and nut (Swedish Wood, 2016a).

2.4.5 Screws

Screws can be fully or partially threaded where the remaining part of the shank is smooth (Blaß and Sandhaas, 2017). Self-tapping screws do not require predrilling and are offered in dimensions up to 1.5 metre long and with a thread diameter of 14 mm (external diameter). Another type of screw is one with a shape pursuant to DIN 7998 which requires predrilling if the diameter is larger or equal to 8 mm. Three different examples of screws are shown in Figure 2.9. Nonetheless, these screws has become less common since the self-tapping screws were introduced.

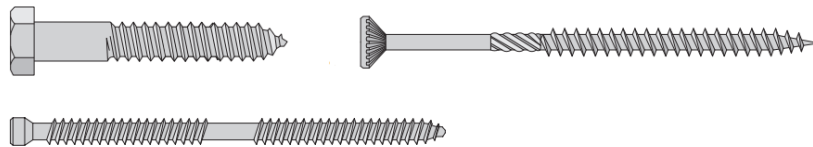

Figure 2.9: Screws (Swedish Wood, 2016a).

2.4.6 Steel rods

Glued-in rods are commonly used in timber constructions with glulam or LVL and could be used both as a joint or reinforcement of timber (Blaß and Sandhaas, 2017), see Figure 2.10. Rods can be used as reinforcement in order to avoid cracking by tensile stresses perpendicular to the grain in beams that are curved or notched. The rods can also transfer loads to the foundation or portal frame and are especially rigid when it comes to axial loads. This connection is advantageous when it comes to resistance to fire since the steel is surrounded by timber.

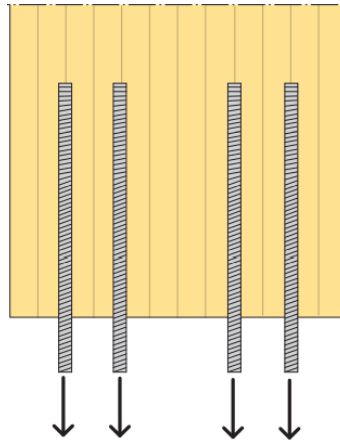

Figure 2.10: Glued-in rods (Swedish Wood, 2016d).

Glued-in rods are often steel rods placed into a predrilled hole with epoxy adhesive, although other material of the rod and other types of adhesives are used as well (Cepelka, 2017). High pull-out strength and high stiffness can be accomplished with high strength adhesive. An important aspect to consider though is the brittle behaviour of the adhesive which can accelerate in a radical collapse in a group of rods. Due to this, the ductile pull out behaviour is valuable and can be acquired by the plastic deformation of the fastener. A problem with this type of connection is the assembling of the rod into the timber and that the success of the grouting cannot be analysed by vision. This process is bounded to take place in a controlled environment with experienced staff and quality control.

Glued connections in general are highly dependent on a controlled environment, since it is sensitive to moisture and temperature, and should thus only be produced in factory and not at the building site (Swedish Wood, 2016a). There is inadequate information about design rules of glued connections in Eurocode and the supplied equations have been conceived by massive testing.

Long threaded rods, LTRs, are high-strength wire rods that initially were used to reinforce glued laminated timber in order to increase the capacity for shear and tensile stresses (Cepelka, 2017). Nowadays, LTRs are used as moment resisting connection in timber structures. The high strength steel is rolled which gives high tensile capacity and resistance to torque.

2.4.7 Carpentry joints

A carpentry joint, also called contact joint, is a connection between two or more members that are linked by the shape of the members (Blaß and Sandhaas, 2017). For example, a cut can be made in one of the members that suits the shape of the end of the second piece, in compression this will make a joint. In order to secure this connection or help transmitting the load, a supplementary fastener can be used, either in wood or metal, see Figure 2.11. Examples of carpentry joints are step joints, mortise and tenon joints along with dovetail joint.

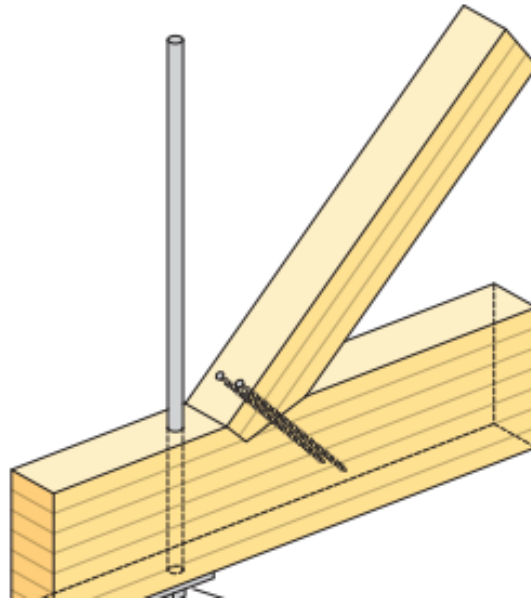

Figure 2.11: Contact joint with supplementary fasteners (Swedish Wood, 2016a).

2.4.8 Steel plates

A common type of steel-to-timber connection is a steel plate connected to timber with some kind of metal fastener (Swedish Wood, 2016a). Steel plates can be arranged inside the timber member, so called slotted-in steel plates, see Figure 2.12, or on the external side of the timber see Figure 2.13. For slotted-in connections, gaps in the timber beam are manufactured where the steel plates are inserted. Predrilled holes for dowels are made both in timber and the steel plates in order to secure the connection. In a situation of fire, steel reaches high temperature fast and hence loses its strength before timber. Therefore, slotted-in connections are preferable since the steel plates are covered by timber and protected from the heat, in comparison with external steel plates for example. This connection is frequently used in trusses in order to transfer axial- and shear forces and in some constellations carry bending moment as well (Cepelka, 2017). To be able to transfer forces and also cover the connection from moisture, the void between the end faces of the two members can be filled with acrylic mortar.

Due to the demands on spacing and distances some connections tend to have large areas which may lead to a need for larger timber members (Cepelka, 2017). To achieve a smooth stress distribution and thereby a ductile behaviour, several thin plates and small dowels could be used. The risk of splitting is higher if shrinkage cracks appear. The load-carrying capacity is reduced by stresses due to moisture which is elevated with enlarged distances between joints. The steel plates are available in standardised measurements with thickness 5, 6, 8, 10, 12, 15 and 20 mm although the thickness should be at least $0.3 \cdot d$, where d is the diameter of the fastener (Swedish Wood, 2016c).

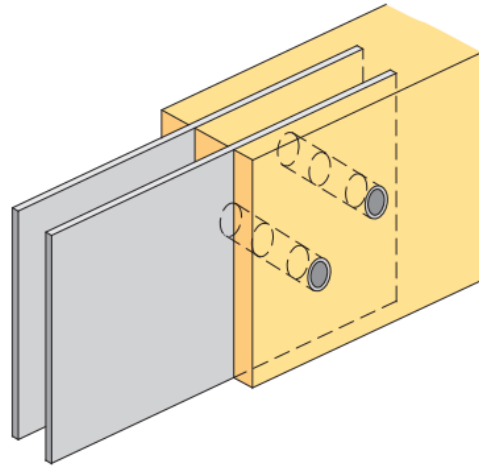

Figure 2.12: Slotted-in steel plates (Swedish Wood, 2016d).

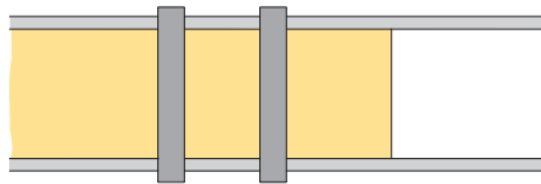

Figure 2.13: External steel plate (Swedish Wood, 2016d).

2.5 Connections in other tall timber buildings

The number of tall timber buildings is increasing in the world and some of the currently tallest ones are mentioned below together with their structural system and the connection types used.

2.5.1 Mjøstårnet, Norway

Mjøstårnet is the currently tallest standing timber building in the world measuring 85 metres (Moelven, 2022). The structural system mainly consists of glulam trusses and beams together with CLT walls (Abrahamsen, 2017). All the connections between glulam components in the building are slotted-in steel plates fastened with dowels.

2.5.2 Treet, Norway

The previously tallest timber building in Norway is the 49 metres high Treet built in 2015. Structurally it has many similarities with Mjøstårnet such as the glulam truss system as well as the slotted-in steel connections (Abrahamsen and Malo, 2014). The dowels used in the connection are, according to norweigan standards, 12 mm combined with 8 mm steel plates. These dimensions are very common when slotted-in steel plates are used as connection in Scandinavia.

2.5.3 Sara Cultural Centre, Sweden

The tallest timber building in Sweden is located in Skellefteå and was completed in 2021, it is the 75 metres high Sara Cultural Centre. The culture centre constitutes the lower part of the building and it is constructed of a combination of glulam and CLT and the higher part is a hotel made of prefabricated CLT modules with two CLT cores (Landel et al., 2021). To stabilise the building and decrease the effects from wind loads the CLT slabs on the 19th and 20th floor have been replaced by 300 mm concrete slabs. The modules in the high part of the building are connected with steel plates and screws, holding the tall structure together (ITB Berlin, 2021).

2.5.4 HoHo, Austria

HoHo in Vienna is a group of five structures where the tallest one measures 84 metres. It is constructed as a composite structure with a combination of wood and concrete with CLT-concrete slabs and glulam columns supplemented with concrete edge beams (Salvadori, 2021). For the connection between slab and edge beam steel rods fixed with concrete grout are used. The same method with steel rod and concrete grout is also used to fix the concrete edge beam to the glulam columns.

2.5.5 Brock Commons Tallwood House, Canada

Brock Commons Tallwood House is an 18-storey and 53 metres tall student residential building situated on the campus of University of British Columbia in Vancouver (Canadian Wood Council, 2016). The structural system consists of two concrete cores, a concrete podium as ground level, glulam columns and CLT slab panels. Different connections are used between different elements but one of the most frequently used is a round steel hollow section with steel plates connected to the top and bottom of each column with 16 mm threaded rods. On the bottom column the CLT panels are supported and connected to the steel plate with similar rods.

2.6 Design of connections

The design of joints is crucial in any structural system and timber constructions are no exception (Blaß and Sandhaas, 2017). Due to the complexity of joints several aspects have to be considered during the design process and different steps in the procedure can be found in this chapter.

2.6.1 Design value

The different equations for strength capacities mentioned in this chapter is often calculated as a characteristic value. To be able to use this value for design, the characteristic strength has to be converted to a design value. The characteristic value is reduced by a factor k_{mod} , which takes load duration and moisture into account, and γ_M , which is a partial factor for material properties (Swedish Wood, 2016a). For timber, the equation 2.1 can be used to calculate the design value from the characteristic value (Swedish Wood, 2016b).

$$F_d = k_{mod} \cdot \frac{f_k}{\gamma_M} \quad (2.1)$$

where

F_d = design value

f_k = characteristic value

k_{mod} = modification factor for duration of load and moisture

γ_M = partial factor for material

2.6.2 Dowel action

To explain dowel action, the dowel can be described as a beam placed in an angle to the force direction, often perpendicular (Swedish Wood, 2016a). When the dowel experience load, this will establish a pressure on the enclosing timber member, so called embedding pressure which acts like a distributed load on the beam. Depending on the slenderness of the dowel, it can bend and thereby create a plastic hinge. Due to this, tensile action can arise in the dowel, along with shear action. The behaviour can be seen in Figure 2.14. By using other dowel type fasteners, the tension action can increase. Example of this kind of dowels are anchoring bolts, mounted screws in a angle to the force direction or a dowel or screw with rough surface.

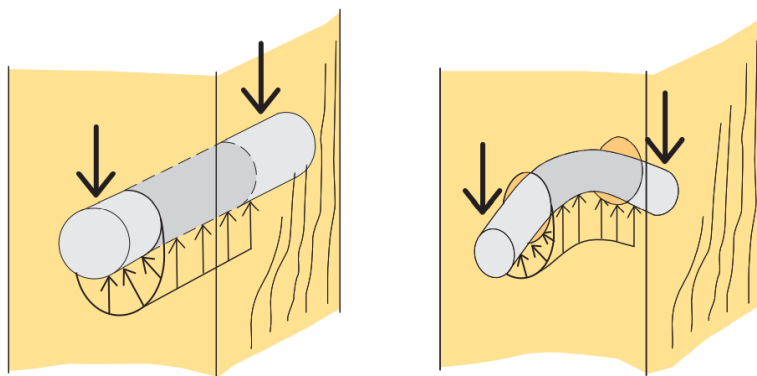

Figure 2.14: Dowel action (Swedish Wood, 2016a).

2.6.3 Embedment strength

The embedment strength of a connection is the maximum strength that the timber surrounding the fastener can resist without being crushed (Swedish Wood, 2016a).

The embedment strength is influenced by a number of aspects. Higher timber density, smaller diameter of the fastener and low moisture content gives a higher embedment strength. When it comes to the angle between load and direction of the grain, compression parallel to the grains yields higher embedment strength than perpendicular to the grains. Furthermore, the arrangement of reinforcement impacts the embedment strength.

If reinforcement is placed in tension perpendicular to the grains it will increase the strength in this direction, which will reduce the risk of a crack initiation i.e the embedment strength.

Besides the factors mentioned above, predrilling will affect the embedment strength since this influences the fibers around the fastener. In a predrilled hole, compression parallel to the grain will transfer most of the load. Although, if there is no predrilling, the load will be transferred in both compression parallel and perpendicular to the grain, see Figure 2.15.

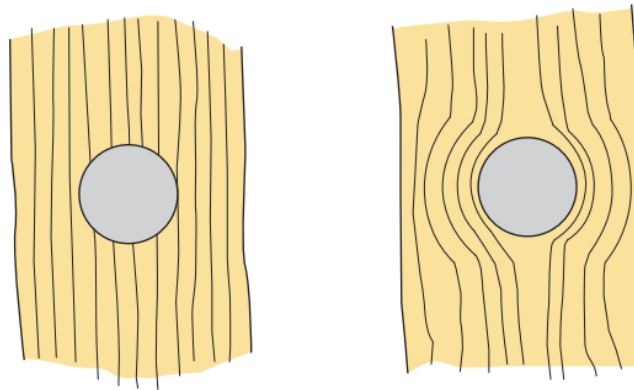

Figure 2.15: Predrilling, embedment strength (Swedish Wood, 2016a).

The embedment strength is described differently if the timber is predrilled or not, corresponding to the following equations 2.2 and 2.3.

Non-predrilled:

$$f_{h,0,k} = 0.082\rho_k d^{-0.3} \quad d \leq 8mm \quad (2.2)$$

Predrilled:

$$f_{h,0,k} = 0.082(1 - 0.01d)\rho_k \quad \text{all fasteners} \quad (2.3)$$

where

$f_{h,0,k}$ [N/mm^2] = embedding strength

d [mm] = diameter

ρ_k [kg/m^2] = characteristic density.

These equations applies for all fasteners although they have to be modified for bolts if there is an angle between the load and the grain direction. This angle has a larger impact for bolts than for nails and the equation has to be reduced by applying Hankinson's formula:

$$f_{h,\alpha,k} = \frac{f_{h,0,k}}{k_{90} \cdot \sin^2\alpha + \cos^2\alpha} \quad (2.4)$$

$$k_{90} = 1.35 + 0.015d \quad (\text{for softwood})$$

Another way to find the embedment strength is through an embedment test where the maximum stress is achieved (Blaß and Sandhaas, 2017). This strength is not purely a material property, rather connected to the system of how the fastener and timber collaborate. The first step of the test is to find the force F that results in a 5 mm deformation. This force is then divided by the projected area of joint on the timber to find the embedment strength.

$$f_h = \frac{F}{d \cdot t} \quad (2.5)$$

where

d = diameter of the fastener

t = thickness of the specimen

2.6.4 Yield moment

The yield moment $M_{y,k}$ is the moment that is required to create a plastic hinge in the dowel (Swedish Wood, 2016a). The characteristic value is calculated according to Equation 2.7 to 2.6:

for all fastener with $d > 8$ mm:

$$M_{y,Rk} = 0.3f_u d^{2.6} \quad [Nmm] \quad (2.6)$$

for nails:

$$M_{y,Rk} = \frac{f_u}{600} 180d^{2.6} \quad [Nmm] \quad (2.7)$$

for square and grooved nails:

$$M_{y,Rk} = \frac{f_u}{600} 270d^{2.6} \quad [Nmm] \quad (2.8)$$

These equations are based on test results although values for yield moment can also be collected from the supplier.

2.6.5 Axial load

An axial load on the fasteners can either be a pull out force or a compressive force, i.e in the axis of the fastener (Blaß and Sandhaas, 2017). There is a couple of failure mechanisms that can happen due to a large axial load. One of them is a withdrawal failure f_{ax} which happens if the fastener is being pulled out and the connection is no longer intact. If there is a large compressive force, the head of the fastener could be pushed through the timber causing head pull-through failure, f_{head} . A third failure mode that should be checked is the tensile failure. Other failure modes are buckling failure and block shear failure.

In order to calculate the withdrawal capacity the parameters f_{ax} and f_{head} is needed (Swedish Wood, 2016a). f_{ax} is the coarseness of the surface around the nail and f_{head} is the anchorage capacity of the nail. According to Eurocode 5 these can be resolved by tests but equation 2.9 and 2.10 are empirical formulas that can be used to find these capacities.

$$f_{ax,k} = 20 \cdot 10^{-6} \rho_k^2 \quad (2.9)$$

$$f_{head,k} = 70 \cdot 10^{-6} \rho_k^2 \quad (2.10)$$

The withdrawal capacity can further be calculated according to the equation 2.11 to 2.13 and differs depending on the type of fasteners.

Smooth nails:

$$F_{ax,Rk} = \min \left\{ \begin{array}{l} f_{ax,k} \cdot d \cdot t_{pen} \\ f_{ax,k} \cdot d \cdot t \cdot f_{head} \cdot d_h^2 \end{array} \right. \quad (2.11)$$

Other than smooth nails:

$$F_{ax,Rk} = \min \left\{ \begin{array}{l} f_{ax,k} \cdot d \cdot t_{pen} \\ f_{head} \cdot d_h^2 \end{array} \right. \quad (2.12)$$

Bolts:

$$F_{ax,washer,Rk} = 3f_{c,90,k}A_{washer} \quad (2.13)$$

where

$f_{ax,k}$ = characteristic withdrawal strength

d_h = diameter of the nail head

A_{washer} = area of the washer

t_{pen} = penetration depth

In some fasteners, the washer is replaced by a full steel plate and the equation has to be adjusted. An area of a circle with diameter D should be used instead of A_{washer} .

$$D = \min \begin{cases} 12t_{steel} \\ 4d \end{cases} \quad (2.14)$$

where

t_{steel} = the thickness of the steel plate
 d = the diameter of the bolt.

Screws:

$$F_{ax,\alpha,Rk} = \frac{n^{0.9} \cdot f_{ax,k} \cdot d \cdot l_{ef} \cdot k_d}{1.2 \cos \alpha^2 + \sin \alpha^2} \quad (2.15)$$

where the withdrawal strength is

$$f_{ax,k} = 0.52 \cdot d^{-0.5} \cdot l_{ef}^{-0.1} \cdot \rho_k^{0.8} \quad (2.16)$$

where

α = angle between screw and grain

$k_d = \min(\frac{d}{8}; 1)$

l_{ef} [mm] = the length of the threaded part embedded in wood

ρ_k [kg/m²] = characteristic density

2.6.6 Block shear failure

In connections with more than one fastener, block shear failure has to be considered (Swedish Wood, 2016d), see Figure 2.16. Equation 2.17 determines the resistance.

$$F_{bs,Rk} = \max \begin{cases} 1.5 \cdot A_{net,t} \cdot f_{t,0,k} \\ 0.7 \cdot A_{net,v} \cdot f_{v,k} \end{cases} \quad (2.17)$$

where

$$A_{net,t} = \sum a_{\perp,i} \cdot \sum t_j \quad (2.18)$$

$$A_{net,v} = \sum a_{\parallel,i} \cdot \sum t_j \quad (2.19)$$

where

$a_{\perp,i}$ = distance between the fasteners perpendicular to the grain

$a_{\parallel,i}$ = distance between the fastener parallel to the grain

t_j = the thickness of the timber between the steel plates.

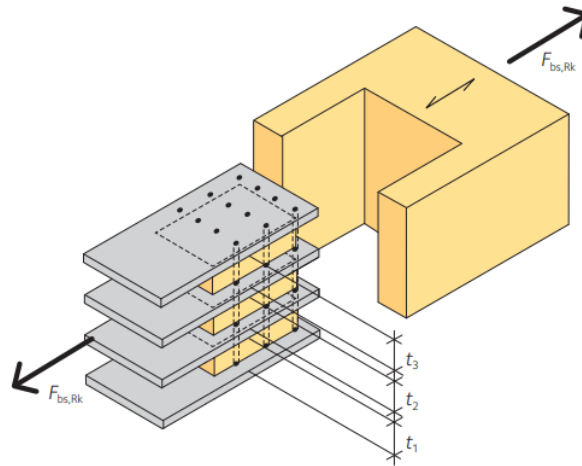

Figure 2.16: Block shear failure (Swedish Wood, 2016a).

2.6.7 Failure modes timber-to-timber connections

Shear failure in the connection depends on the embedding strength, yield moment and thickness of timber members which can result in different kinds of failure modes (Swedish Wood, 2016a). These failure modes are listed in Eurocode 5, Chapter 8 and are divided in groups depending on the number of shear planes and the type of connection, for example timber-to-timber joints or steel to timber joints.

The failure mode approach is called the Johansen theory since he was the first to develop models for the load-carrying capacity for dowelled joints (Swedish Wood, 2016a). He found that different failure modes developed various number of plastic hinges in the dowel. Failure mode I does not have a plastic hinge (only failure in timber), failure mode II develops one hinge and failure mode III creates two plastic hinges. The equations can be seen below. The lowest of these strengths should be used for design.

Failure mode I, single shear

The failure is in the surrounding timber, a result of the embedding pressure, see Figure 2.17. The failure mode is therefore calculated in accordance with the embedding strength as:

a)

$$F_{v,Rk} = f_{h,1,k} t_1 d \quad (2.20)$$

b)

$$F_{v,Rk} = f_{h,2,k} t_2 d \quad (2.21)$$

c)

$$F_{v,Rk} = \frac{f_{h,1,k} t_1 d}{1 + \beta} \left(\sqrt{\beta + 2\beta^2 \left(1 + \frac{t_2}{t_1} + \left(\frac{t_2}{t_1} \right)^2 \right) + \beta^3 \left(\frac{t_2}{t_1} \right)^2} - \beta \left(1 + \frac{t_2}{t_1} \right) \right) + \frac{F_{ax,Rk}}{4} \quad (2.22)$$

where

- $f_{h,1,k}$ = embedding strength for the thinner timber member
- $f_{h,2,k}$ = embedding strength for the thicker timber member
- t_1 = thickness of the thinner timber member
- t_2 = thickness of the thicker timber member
- d = dimension of the dowel
- $\beta = \frac{f_{h,2,k}}{f_{h,1,k}}$ which takes different species of wood into account
- $F_{ax,Rk}$ = anchorage capacity

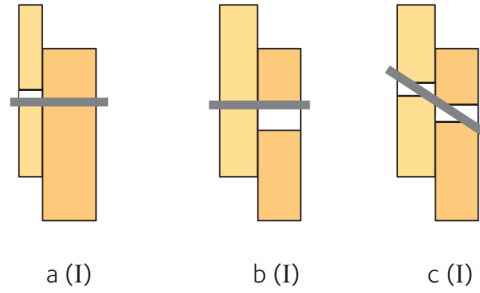

Figure 2.17: Failure mode I (Swedish Wood, 2016a).

Failure mode II, single shear

In this failure mode, the dowel will curve inside the timber and therefore create a plastic hinge, see Figure 2.18. The strength can be calculated as equation 2.23 and 2.24:

d)

$$F_{v,Rk} = 1.05 \frac{f_{h,1,k} t_1 d}{2 + \beta} \left(\sqrt{2\beta(1 + \beta) + \frac{4\beta(2 + \beta) M_{y,R,k}}{f_{h,1,k} d t_1^2}} - \beta \right) + \frac{F_{ax,Rk}}{4} \quad (2.23)$$

e)

$$F_{v,Rk} = 1.05 \frac{f_{h,1,k} t_1 d}{1 + 2\beta} \left(\sqrt{2\beta^2(1 + \beta) + \frac{4\beta(1 + 2\beta) M_{y,R,k}}{f_{h,1,k} d t_1^2}} - \beta \right) + \frac{F_{ax,Rk}}{4} \quad (2.24)$$

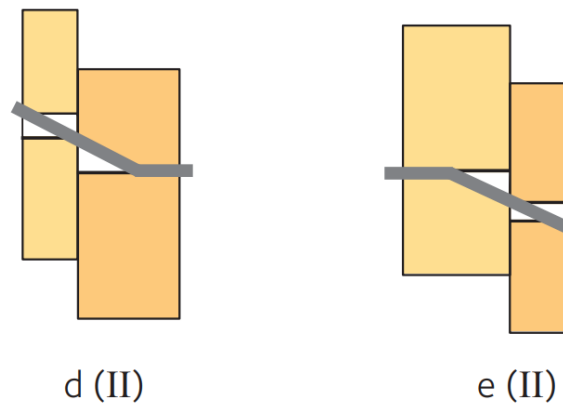

Figure 2.18: Failure mode II (Swedish Wood, 2016a).

Failure mode III, single shear

In failure mode III, two plastic hinges will happen as the dowel will bend in both timber members, see Figure 2.19. This mode is the most advantageous when it comes to ductility.

f)

$$F_{v,R,k} = 1.15 \sqrt{\frac{2\beta}{1+\beta}} \sqrt{2M_{y,r,k} f_{h,1,k} d} + \frac{F_{ax,Rk}}{4} \quad (2.25)$$

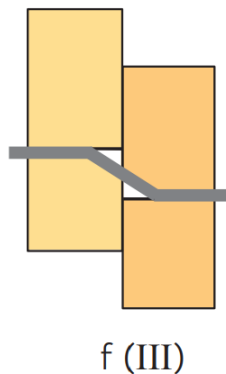

Figure 2.19: Failure mode III (Swedish Wood, 2016a).

Failure modes, double shear

For double shear timber-to-timber connections, failure modes are developed almost in the same way as the failure modes for single shear although the rotation of the dowel is hindered since the load is symmetrical (Swedish Wood, 2016a). The failure modes can be seen in Figure 2.20. The equations for the failure modes for double shear can be seen below.

g)
$$F_{v,Rk} = 0.4f_{h,k}t_1d \quad (2.26)$$

h)
$$F_{v,Rk} = 0.5f_{h,2,k}t_2d \quad (2.27)$$

j)
$$F_{v,Rk} = 1.05\frac{f_{h,1,k}t_1d}{2+\beta} \left(\sqrt{2\beta(1+2\beta) + \frac{4\beta(2+\beta)M_{y,Rk}}{f_{h,1,k}dt_1^2}} - \beta \right) + \frac{F_{ax,Rk}}{4} \quad (2.28)$$

k)
$$F_{v,Rk} = 1.15\sqrt{\frac{2\beta}{1+\beta}}\sqrt{2M_{y,Rk}f_{h,1,k}d} + \frac{F_{ax,Rk}}{4} \quad (2.29)$$

where
 $M_{y,Rk}$ = yield moment

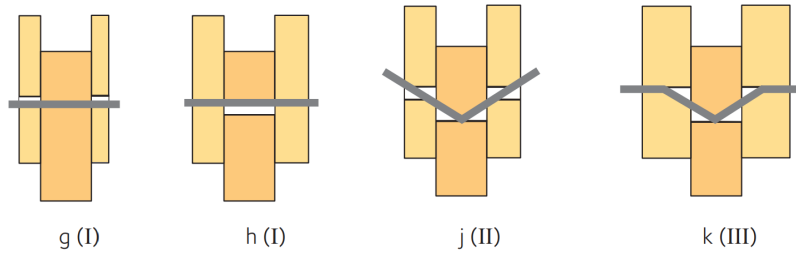

Figure 2.20: Failure modes double shear (Swedish Wood, 2016a).

2.6.8 Failure modes steel to timber connections

When using a steel-to-timber connection, the plastic hinge almost always appear at the intersection between the steel and the timber (Swedish Wood, 2016a). This results in a higher capacity than a timber-to-timber connection. In order for the plastic hinge to appear, the condition below should be fulfilled.

$$t_{steel} \geq d \Rightarrow \text{fixed support}$$

or

$$t_{steel} \leq 0.5d \Rightarrow \text{pinned support}$$

This means that, in order to arrange a fixed support for the development of a plastic hinge, the thickness of the steel plate has to be larger than or equal to the diameter of the fastener. Furthermore, the connection is pinned if the steel plate has a thickness less than or equal to half the diameter of the fastener. In this case, there will not be a plastic hinge although the dowel will rotate in the hole anyway. The resistance will increase if a plastic hinge develops.

Slotted-in steel plates

The resistance capacity is obtained in the same way as for the timber-to-timber connection although the position of the plastic hinge is prescribed to the intersection of the steel and timber. Also, there is no requirement of the steel plate thickness, the plastic hinge will form irrespective of the thickness. Although, the thickness of the steel plate needs to be enough to provide for the embedding strength. The resistance can be described by Equation 2.30 - 2.32 with the associated Figures 2.21 - 2.23:

$$F_{v,Rk} = f_{h,k} t_1 d \quad (2.30)$$

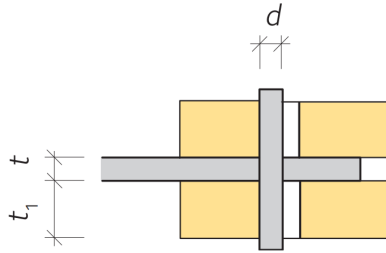

Figure 2.21: Failure mode to Equation 2.30 (Swedish Wood, 2016a).

$$F_{v,Rk} = f_{h,k} t_1 d \left(\sqrt{2 + \frac{4M_{y,Rk}}{f_{h,1,k}}} - 1 \right) + \frac{F_{ax,Rk}}{4} \quad (2.31)$$

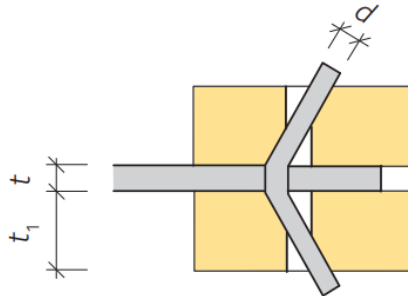

Figure 2.22: Failure mode to Equation 2.31 (Swedish Wood, 2016a).

$$F_{v,Rk} = 2.3 \sqrt{M_{y,Rk} f_{h,k} d} + \frac{F_{ax,Rk}}{4} \quad (2.32)$$

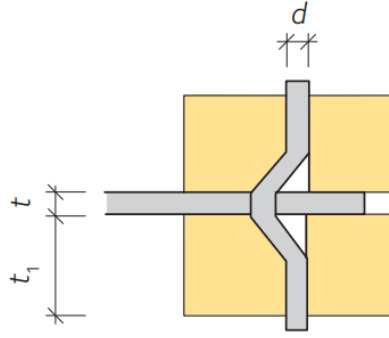

Figure 2.23: Failure mode to Equation 2.32 (Swedish Wood, 2016a).

Several slotted-in steel plates

Using several slotted-in steel plates in a timber connection instead of a single plate could increase the capacity of the connection (Swedish Wood, 2016d). It is however important to check the resistance to failure modes according to the following condition:

The distance between the steel plate and the edge of the timber, t_1 should fulfill

$$t_1 > \sqrt{2} \cdot \sqrt{\frac{M_{y,k}}{f_{h,k} \cdot d}} \quad (2.33)$$

The distance between the steel plates, t_2 should fulfill

$$t_2 > 1.15 \cdot 4 \cdot \sqrt{\frac{M_{y,k}}{f_{h,k} \cdot d}} \quad (2.34)$$

The load-bearing capacity is divided into two parts:

$$R_k = R_{k,centre} + R_{k,lateral} \quad (2.35)$$

where $R_{k,centre}$ and $R_{k,lateral}$ for different number of plates can be seen in Equations 2.36-2.43.

Two slotted-in steel plates

For two slotted-in steel plates, following equations could be used for capacity.

$$R_{k,centre} = 2 \cdot 1.15 \cdot \sqrt{2} \cdot \sqrt{2 \cdot M_{y,Rk} \cdot f_{h,k} \cdot d} \quad (2.36)$$

$$R_{k,lateral} = 2 \cdot \begin{cases} f_{h,k} \cdot d \cdot t_1 \cdot \left(\sqrt{2 + \frac{4 \cdot M_{y,Rk}}{f_{h,k} \cdot d \cdot t_1^2}} - 1 \right) & \text{if } \sqrt{2} \cdot \sqrt{\frac{M_{y,k}}{f_{h,k} \cdot d}} < t_1 \leq 1.15 \cdot 4 \cdot \sqrt{\frac{M_{y,k}}{f_{h,k} \cdot d}} \\ 1.15 \cdot \sqrt{2} \cdot \sqrt{2 \cdot M_{y,Rk} \cdot f_{h,k} \cdot d} & \text{if } t_1 \geq 1.15 \cdot 4 \cdot \sqrt{\frac{M_{y,k}}{f_{h,k} \cdot d}} \end{cases} \quad (2.37)$$

Three slotted-in steel plates

$$R_{k,centre} = 2 \cdot (2 \cdot 1.15 \cdot \sqrt{2} \cdot \sqrt{2 \cdot M_{y,Rk} \cdot f_{h,k} \cdot d}) \quad (2.38)$$

$$R_{k,lateral} = 2 \cdot \begin{cases} f_{h,k} \cdot d \cdot t_1 \cdot \left(\sqrt{2 + \frac{4 \cdot M_{y,Rk}}{f_{h,k} \cdot d \cdot t_1^2}} - 1 \right) & \text{if } \sqrt{2} \cdot \sqrt{\frac{M_{y,k}}{f_{h,k} \cdot d}} < t_1 \leq 1.15 \cdot 4 \cdot \sqrt{\frac{M_{y,k}}{f_{h,k} \cdot d}} \\ 1.15 \cdot \sqrt{2} \cdot \sqrt{2 \cdot M_{y,Rk} \cdot f_{h,k} \cdot d} & \text{if } t_1 \geq 1.15 \cdot 4 \cdot \sqrt{\frac{M_{y,k}}{f_{h,k} \cdot d}} \end{cases} \quad (2.39)$$

Four slotted-in steel plates

$$R_{k,centre} = 3 \cdot (2 \cdot 1.15 \cdot \sqrt{2} \cdot \sqrt{2 \cdot M_{y,Rk} \cdot f_{h,k} \cdot d}) \quad (2.40)$$

$$R_{k,lateral} = 2 \cdot \begin{cases} f_{h,k} \cdot d \cdot t_1 \cdot \left(\sqrt{2 + \frac{4 \cdot M_{y,Rk}}{f_{h,k} \cdot d \cdot t_1^2}} - 1 \right) & \text{if } \sqrt{2} \cdot \sqrt{\frac{M_{y,k}}{f_{h,k} \cdot d}} < t_1 \leq 1.15 \cdot 4 \cdot \sqrt{\frac{M_{y,k}}{f_{h,k} \cdot d}} \\ 1.15 \cdot \sqrt{2} \cdot \sqrt{2 \cdot M_{y,Rk} \cdot f_{h,k} \cdot d} & \text{if } t_1 \geq 1.15 \cdot 4 \cdot \sqrt{\frac{M_{y,k}}{f_{h,k} \cdot d}} \end{cases} \quad (2.41)$$

Five slotted-in steel plates

$$R_{k,centre} = 4 \cdot (2 \cdot 1.15 \cdot \sqrt{2} \cdot \sqrt{2 \cdot M_{y,Rk} \cdot f_{h,k} \cdot d}) \quad (2.42)$$

$$R_{k,lateral} = 2 \cdot \begin{cases} f_{h,k} \cdot d \cdot t_1 \cdot \left(\sqrt{2 + \frac{4 \cdot M_{y,Rk}}{f_{h,k} \cdot d \cdot t_1^2}} - 1 \right) & \text{if } \sqrt{2} \cdot \sqrt{\frac{M_{y,k}}{f_{h,k} \cdot d}} < t_1 \leq 1.15 \cdot 4 \cdot \sqrt{\frac{M_{y,k}}{f_{h,k} \cdot d}} \\ 1.15 \cdot \sqrt{2} \cdot \sqrt{2 \cdot M_{y,Rk} \cdot f_{h,k} \cdot d} & \text{if } t_1 \geq 1.15 \cdot 4 \cdot \sqrt{\frac{M_{y,k}}{f_{h,k} \cdot d}} \end{cases} \quad (2.43)$$

External steel plates

Instead of inserting steel plates into the timber, the plates can be placed externally on the sides of the timber members (Swedish Wood, 2016a). If a steel plate is placed with nails on one side, this creates a single shear plane. If there is steel plates on both sides, dowels can go through the entire timber member which construct a double shear plane. The expressions differ depending on the number of shear planes and the thickness of the steel plate.

Capacity for single shear steel-to-timber joint, $t \geq d$.

$$F_{v,Rk} = f_{h,k}t_1d \quad (2.44)$$

$$F_{v,Rk} = f_{h,k}t_1d \left(\sqrt{2 + \frac{4M_{y,Rk}}{f_{h,k}dt_1^2}} - 1 \right) + \frac{F_{ax,Rk}}{4} \quad (2.45)$$

$$F_{v,Rk} = 2.3\sqrt{M_{y,Rk}f_{h,k}d} + \frac{F_{ax,Rk}}{4} \quad (2.46)$$

Capacity for single shear steel-to-timber, $t \leq 0.5d$

$$F_{v,Rk} = 0.4f_{h,k}t_1d \quad (2.47)$$

$$F_{v,Rk} = 1.15\sqrt{2M_{y,Rk}f_{h,k}d} + \frac{F_{ax,Rk}}{4} \quad (2.48)$$

Capacity for a double shear steel-to-timber joint, per shear plane, $t \geq d$

$$F_{v,Rk} = 0.5f_{h,2,k}t_2d \quad (2.49)$$

$$F_{v,Rk} = 2.3\sqrt{M_{y,Rk}f_{h,k}d} + \frac{F_{ax,Rk}}{4} \quad (2.50)$$

Capacity for double shear steel-to-timber joint, per shear plane, $t \leq 0.5d$

$$F_{v,Rk} = 0.5f_{h,2,k}t_2d \quad (2.51)$$

$$F_{v,Rk} = 1.15\sqrt{2M_{y,Rk}f_{h,2,k}d} + \frac{F_{ax,Rk}}{4} \quad (2.52)$$

2.6.9 Capacity for glued-in rods

For glued-in rods, the load-bearing capacity in tension for the rods and the withdrawal capacity for the timber can be calculated by the following equations 2.53 - 2.6.9, according to the Swedish approval 1396/78, issued by SP, Swedish Technical Research Institutes (Swedish Wood, 2016d).

Load-bearing capacity for rods in tension, characteristic value:

$$R_{t,k,rod} = 0.6 \cdot f_{ub} \cdot A_s \quad (2.53)$$

Load-bearing capacity for rods in tension, design value:

$$R_{t,d,rod} = R_{t,k,rod} \cdot (1/1.2) \quad (2.54)$$

Withdrawal capacity timber, characteristic value:

$$R_{t,k,timber} = \pi \cdot (d + 1mm) \cdot l_i \cdot f_{ax,k} \cdot k_1 \cdot \kappa_1 \quad (2.55)$$

Withdrawal capacity timber, design value:

$$R_{t,d,timber} = R_{t,k,timber} \cdot \frac{k_{mod}}{\gamma_M} \quad (2.56)$$

where

f_{ub} = tensile strength

$f_{ax,k}$ = 5.5 MPa

l_i = length of glued-in part of the rod

A_s = Cross-sectional area of the rods

d = diameter of the rod

$\kappa_1 = \begin{cases} 1 & \text{f\"or climate class 1} \\ 0.85 & \text{f\"or climate class 2} \end{cases}$

$k_1 = \begin{cases} 0.55 & \text{for M10} \\ 0.59 & \text{for M12} \\ 0.64 & \text{for M16} \\ 0.69 & \text{for M20} \end{cases}$

2.6.10 Capacity for long threaded rods

In general, there are two main producers of these LTRs that are commonly used; SFS Intec and SPAX (Cepelka, 2017). Since Eurocode 5 is lacking design rules for long threaded bolts, technical approvals from the producers are provided.

SFS Intec (WB system):

$$R_{ax,k} = f_{ax,k} l_{ef} d \quad (2.57)$$

$$f_{ax,k} = 0.52 d^{-0.5} l_{ef}^{-0.1} \rho_k^{0.8} \quad (2.58)$$

SPAX

$$R_{ax,k} = f_{ax,k} l_{ef} d \left(\frac{\rho_k}{380} \right)^{0.8} \quad (2.59)$$

$$f_{ax,k} = 10.2 \quad N/mm^2 \quad (2.60)$$

where

- $R_{ax,k}$ [N] = characteristic withdrawal capacity
- $f_{ax,k}$ [N] = characteristic withdrawal strength
- ρ_k [kg/m³] = timber density (characteristic value)
- d [mm] = outer diameter of the LTRs
- l_{ef} [mm] = effective embedment length of the rods.

According to (Cepelka, 2017), none of these equations involves the angle between rod and grain γ , however the following condition needs to be fulfilled

$$45^\circ \leq \gamma \leq 90^\circ \quad (2.61)$$

and

$$4d \leq l_{ef} \leq 1000mm \quad (2.62)$$

2.6.11 Deformation

The local analysis of joint behaviour is an important aspects of the design process, in combination with global behaviour (Blaß and Sandhaas, 2017). The joint behaviour affects deformations which can be investigated through tests of different connections. These tests show that metal fasteners such as nails, bolts and punched metal fasteners are more prone to deform than for example rigid glued. Although, a glued joint fails at a low deformation whereas nails combat comparatively high deformation without failure. The ability of tolerating larger deformations entails a warning signal long before failure and occasionally redistribution of stresses due to plastic deformation or creep. This behaviour in combination with embedment strength of the surrounding timber makes the elastic-plastic ductile behaviour of the laterally loaded dowel joints. In order to achieve this, minimum spacings and distances between edge and joint is obligatory and assures that no brittle failure can take place.

2.6.12 Minimum distances

In order for the design equations to be accurate, minimum lengths are required for spacing and end/edge distances (Blaß and Sandhaas, 2017). The minimum values differ depending on the type of connection and are described below.

Fasteners

For fasteners, the minimum distances for bolts and dowels can be found in Table 2.2 and Table 2.3 (Swedish Wood, 2016a). An explanation of the different distances can be seen in Figure 2.24. Minimum distances for nails have not been listed since bolts and dowels are more relevant for this case. These distances have been conceived by tests and experiences and differs depending on, among others, which fasteners that are included (Blaß and Sandhaas, 2017). These spaces distinguishes between the direction parallel and perpendicular to the grains. The distance a_1 parallel to the grain decides the effective number of fasteners. If this distance is inadequate, this can lead to splitting in the grain along the row of fasteners. In the other direction, perpendicular to the grain, spacing a_2 is compulsory although this will not affect splitting. The distance to edge/end has to be considered to avoid premature splitting. It is necessary to distinguish between a loaded and unloaded edge since a loaded edge required larger distance.

Table 2.2: Minimum distances end/edge and spacing for bolts, in mm (Swedish Wood, 2016b).

Distance	Angle	Minimum distance
a_1 (parallel to grain)	$0^\circ \leq \alpha \leq 360^\circ$	$(4 + \cos \alpha) \cdot d$
a_2 (perpendicular to grain)	$0^\circ \leq \alpha \leq 360^\circ$	$4 \cdot d$
$a_{3,t}$ (loaded end)	$-90^\circ \leq \alpha \leq 90^\circ$	$\max(7 \cdot d; 80\text{mm})$
$a_{3,c}$ (unloaded end)	$90^\circ \leq \alpha < 150^\circ$	$(1 + 6 \cdot \sin \alpha) \cdot d$
	$150^\circ \leq \alpha < 210^\circ$	$4 \cdot d$
	$210^\circ \leq \alpha \leq 270^\circ$	$(1 + 6 \sin \alpha) \cdot d$
$a_{4,t}$ (loaded edge)	$0^\circ \leq \alpha \leq 180^\circ$	$\max[(2 + 2 \cdot \sin \alpha) \cdot d; 3 \cdot d]$
$a_{4,c}$ (unloaded edge)	$180^\circ \leq \alpha \leq 360^\circ$	$3 \cdot d$

Table 2.3: Minimum distances end/edge and spacing for dowels, in mm (Swedish Wood, 2016b).

Distance	Angle	Minimum distance
a_1 (parallel to grain)	$0^\circ \leq \alpha \leq 360^\circ$	$(3 + 2 \cdot \cos \alpha) \cdot d$
a_2 (perpendicular to grain)	$0^\circ \leq \alpha \leq 360^\circ$	$3 \cdot d$
$a_{3,t}$ (loaded end)	$-90^\circ \leq \alpha \leq 90^\circ$	$\max(7 \cdot d; 80\text{mm})$
$a_{3,c}$ (unloaded end)	$90^\circ \leq \alpha < 150^\circ$	$a_{3,t} \cdot \sin \alpha $
	$150^\circ \leq \alpha < 210^\circ$	$\max(3.5 \cdot d; 40\text{mm})$
	$210^\circ \leq \alpha \leq 270^\circ$	$a_{3,t} \cdot \sin \alpha $
$a_{4,t}$ (loaded edge)	$0^\circ \leq \alpha \leq 180^\circ$	$\max[(2 + 2 \cdot \sin \alpha) \cdot d; 3 \cdot d]$
$a_{4,c}$ (unloaded edge)	$180^\circ \leq \alpha \leq 360^\circ$	$3 \cdot d$

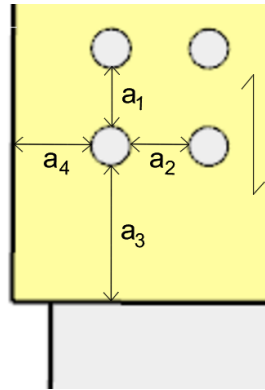

Figure 2.24: Minimum distances between fasteners a_1 , a_2 , a_3 and a_4 .

Steel plates

For slotted-in steel plates, minimum distances between steel plates and between the edge and steel plate are also required in order to use the Johansen theory (Swedish Wood, 2016d). The distance between the edge and the first steel plate is called t_1 and the spacing between the steel plates is called t_2 . The requirements can be seen in Equation 2.63 and 2.64 and a description of the distances can be seen in Figure 2.25.

$$t_1 > \sqrt{2} \cdot \sqrt{\frac{M_{y,k}}{f_{h,k} \cdot d}} \quad (2.63)$$

$$t_2 \geq 1.15 \cdot 4 \cdot \sqrt{\frac{M_{y,k}}{f_{h,k} \cdot d}} \quad (2.64)$$

$M_{y,k}$ = yield moment, characteristic value $f_{h,k}$ = embedment strength, characteristic value d = diameter of the dowel

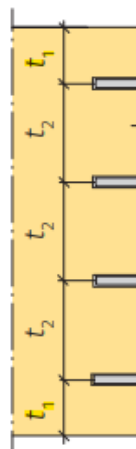

Figure 2.25: Minimum distances t_1 and t_2 (Swedish Wood, 2016d).

Rods

For glued-in rods, minimum spacing and minimum distances to edge is recommended according to Equations 2.65 and 2.66 (Swedish Wood, 2016d). The distances a_1 and a_2 can be seen in Figure 2.26.

$$a_1 = 4 \cdot d \quad \text{for spacing between rods} \quad (2.65)$$

$$a_2 = 2.5 \cdot d \quad \text{for spacing between rods} \quad (2.66)$$

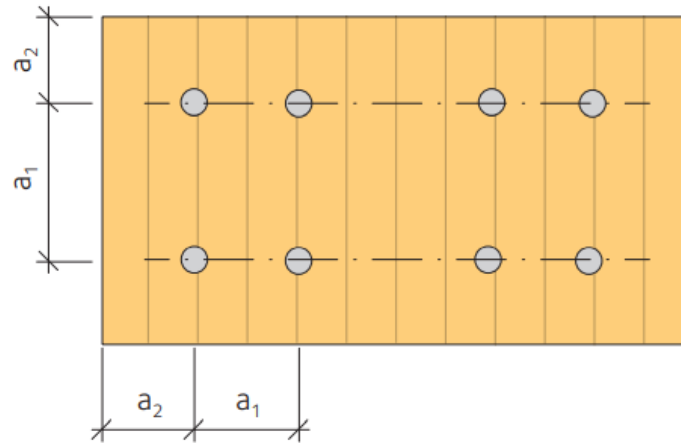

Figure 2.26: Minimum distances glued-in rods (Swedish Wood, 2016d).

2.6.13 Effective number of fasteners

For a connection where fasteners are arranged in a row parallel to the grain, the group effect has to be considered (Swedish Wood, 2016a). Therefore, effective number of nails, n_{ef} , has to be calculated and used for further calculations. If the spacing between nails is larger or equal to $14 \cdot d$, there is no group effect. The formulas for n_{ef} can be seen in equation 2.67 and 2.68:

For nail, staples and screws $d \leq 6mm$

$$n_{ef} = n^{k_{ef}} \quad (2.67)$$

where

n = number of fasteners

$k_{ef} = 1$ if $a_1 \geq 14 \cdot d$

$k_{ef} = 0.85$ if $a_1 = 10 \cdot d$

$k_{ef} = 0.7$ if $a_1 = 7 \cdot d$

For bolts, dowels and screws $d \geq 6mm$

$$n_{ef} = \min \left\{ n, n^{0.9 \sqrt[4]{\frac{a_1}{13 \cdot d}}} \right\} \quad (2.68)$$

where
 a_1 = spacing parallel to the grain

2.6.14 Combined loads

In some cases, both shear and axial load acts on the joint and the interaction between the two needs to be considered, according to equations 2.69 and 2.70 (Swedish Wood, 2016a).

For smooth nails:

$$\frac{F_{ax,Ed}}{F_{ax,Rd}} + \frac{F_{v,Ed}}{F_{v,Rd}} \leq 1 \quad (2.69)$$

For other types of nails and screws

$$\left(\frac{F_{ax,Ed}}{F_{ax,Rd}} \right)^2 + \left(\frac{F_{v,Ed}}{F_{v,Rd}} \right)^2 \leq 1 \quad (2.70)$$

where $F_{v,Rk}$ is described in Sections 2.6.7 and 2.6.8.

2.6.15 Stiffness

Stiffness in a timber structure is affected by a number of parameters and has to be considered in different ways. For example, the timber itself has a stiffness parameter described by the elastic modulus (Swedish Wood, 2016a). There are different elastic modulus depending on the type of timber, type of analysis and the load direction (Swedish Wood, 2016b). The type of timber could for example be structural timber, glulam or LVL and the direction is either perpendicular or parallel to the grains. Further, the elastic modulus differ depending on the type of analysis and is related to the variability of the elastic modulus where the $E_{0,05}$ (the fifth percentile) is for capacity analysis and E_{mean} (the mean value) is for deformation calculation. Another aspect affecting the stiffness of the timber is the moisture content, where lower content means higher stiffness. The relation between moisture content and stiffness can be described as linearly decreasing, until the fibre saturation point is reached, where there is almost no difference in stiffness although decreasing moisture content.

The elastic modulus is also affecting the bending stiffness which has large influence on the load-bearing capacity (Blaß and Sandhaas, 2017). This stiffness restrains the beam to bend around its major axis, often the vertical plane, but is also important to ensure stiffness in the horizontal plane to reduce the risk for lateral torsional buckling. The bending stiffness can be increased by reinforcement in parts of the timber that experience compression (Swedish Wood, 2016a).

A mechanical connection between structural members often implies semi-rigidity which leads to relative displacements between the members (Blaß and Sandhaas, 2017). This means that the Bernoulli hypothesis plane sections remains plane is no longer valid, which in turn means that the Euler-Bernoulli beam theory can not be enforced. This impacts the overall displacement of the member and has to be considered as it can impact the global deformation.

To account for the semi-rigidity of the timber joint, the slip modulus K_{ser} should be studied (Blaß and Sandhaas, 2017). K_{ser} is the slip modulus for joints with mechanical fasteners in service limit state and relies on the diameter and type of connection as well as the density of the timber. K_u is the slip modulus for the ultimate limit state that is used to decide the effective bending stiffness in connections with mechanical fasteners.

In the serviceability limit state, the slip modulus K_{ser} is calculated to equation 2.71 (Swedish Wood, 2016a):

$$K_{ser} = \begin{cases} \rho_m^{1.5} d / 23 & \text{(bolts, dowels, screws and predrilled nails)} \\ \rho_m^{1.5} d^{0.8} / 30 & \text{(non predrilled nails)} \end{cases} \quad (2.71)$$

where

$$\begin{aligned} \rho_m [kg/m^3] &= \text{mean density of wood} \\ d [mm] &= \text{diameter of the fastener} \end{aligned}$$

For the ultimate limit state, the slip modulus is then determined as equation 2.72

$$K_u = \frac{2}{3} K_{ser} \quad (2.72)$$

2.7 Robustness

Structural robustness is defined as the ability to resist unforeseen loads to cause large damages or collapses (Voulpiotis, 2022). If an important load-bearing element is damaged and no longer capable of carrying the load it is designed for it is a necessity that the surrounding elements can handle the load redistribution and have ability to carry the load to avoid a total or partial collapse of the structure. Studies can be made by removing different load-bearing elements in the structural models and investigate how the capacity is affected (Huber et al., 2018). There are several methods to prevent collapses due to unexpected loads and some of the possible ones are shortly described below:

- The redundancy should be sufficient to allow for a load transfer in case of failure of an element. If collapse can be avoided even in case of failure of a critical component the structure is redundant and has a sufficient way of transferring the loads to different load paths.
- Structural continuity is an efficient way of increasing the robustness of a building. This can be provided by establishing ties, both horizontal and vertical,

that connects different structural units. The purpose of using ties is to create continuous load paths and to limit the displacements.

- The alternative load path analysis (ALPA) is a way of investigating how the loads are absorbed in other paths when failure occurs. By studying this the design can be adjusted until the desired load path is achieved.
- Ductility means that a material can have plastic behaviour before failure. The deformation that occurs during ductile behaviour is preferred to brittle failure since they become an indication before collapse. Therefore a higher ductility also can lead to an increased robustness.
- There are some specific mechanisms capable of redistributing loads to avoid collapse in case of local failure. The mechanisms mostly depend on the plasticity of the material or geometric conditions.
- Robustness can also be attained by compartmentalisation which means that the structure is divided in different independent structures that should be robust by themselves and therefore also creates a robust construction.
- To make a key element design is another method which means that some structural elements are appointed as key elements with the purpose to resist high loads by being overdesigned. This is to decrease the vulnerability of the structure since the key elements are the ones most likely to be exposed for such type of loads.

3

Previous studies

In this chapter some of the results from previous parts of The 200 m timber tower project will be presented. The most relevant results for this study are the final geometry, its dimensions and the total displacements for the structure.

3.1 Geometry

The main purpose of previously years master thesis projects was to find the optimal geometry for the structure. This was done by testing many different structural designs to find one that fulfills all the structural requirements well. The majority of the structural analysis was done using Grasshopper and relevant plug-ins.

The study gave that the most optimal geometry in terms of structural efficiency, dynamic performance, use of material and rental area was a hyperboloid with a turning structure, see Figure 3.1. The hyperboloid consists of a squared core surrounded by a diagrid truss system tied together by horizontal beams positioned in circles around the structure.

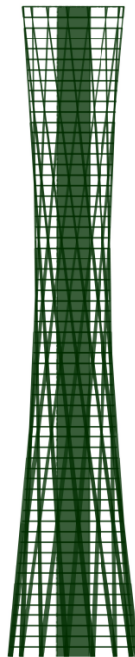

Figure 3.1: The hyperboloid structure.

3.2 Dimensions

The core of the building is constructed of cross-laminated timber panels of the strength C30. Both the trusses and the beams have a squared cross-section made of glulam strength GL30h. Different forces will appear on different heights in the building and therefore different dimensions of the diagrid trusses will be used on different levels of the building. The largest forces and therefore also the largest truss dimensions will emerge in the bottom floors. The dimensions will then be decreased going upwards since the forces decrease with the height of the building. Table 3.1 shows the truss dimensions divided in five different groups dependent on the floor level. The horizontal beams will however have the same cross-section throughout the whole building with the dimensions of 250x250 mm.

Table 3.1: Truss and beam dimensions for the different floors.

Floor	Truss dimension [mm]	Beam dimension [mm]
1-10	850x850	250x250
11-31	700x700	
32-43	550x550	
44-52	400x400	
53-62	250x250	

3.3 Displacements

The maximum horizontal displacements of the final geometry of the building were analysed for both fixed and pinned connections. Fixed means that the components are rigid in all directions, both translational and rotational, and pinned means that they are translationally rigid but free to move rotationally. The displacement analysis was made with the characteristic load combination in the serviceability limit state and the results are presented in Table 3.2.

Table 3.2: Maximum horizontal displacements in SLS.

	Maximum displacement [mm]
Fixed joints	170.1
Pinned joints	203.3

It was stated that the connections will be somewhere inbetween fixed and pinned and that none of the results therefore represents the real behaviour. Thus, the real displacement will probably be between 170.1 mm and 203.3 mm, which is below the comfort criteria of 400 mm.

4

Method

This chapter involves a description of the method used for the analyses in this thesis. The procedures of extracting of the normal forces, hand calculation of the connection, analysis of stiffness and optimization of the connection are described.

4.1 Normal forces

As mentioned, five different truss dimensions were used in the geometry from previous studies. The dimensions of the beams were decreasing with the height since the applied forces were decreasing. The floor levels were therefore divided into five groups depending on the beam sizes, see Table 3.1. Although, since the parameters affecting the stiffness and the connection for the most critical joint were investigated in this study, only one beam dimension was of interest. The largest beam receives largest forces and was therefore considered as the most critical joint and the maximum normal force was therefore needed for this beam. Nevertheless, maximum normal forces were extracted for each of the five different dimensions of the beam in order to see the difference along the height of the building.

The Grasshopper model of the proposed geometry which were established in the previous part was used for finding the maximum normal forces used in this study. The first step was to add a module for extracting node forces, which presented a list of the normal forces. From this list, forces for the elements within each group of floor levels could be extracted and the maximum force from this group of elements was found. In this way, maximum normal force for each beam dimension and the locations in the building could be found.

In this study, normal forces were found both for ULS and SLS load combination. For both combinations, the self-weight was included in the permanent load whereas the imposed load and the wind load were counted as variable loads. The imposed load for this building was set to 3 kN/m^2 since this building is assumed to be an office building.

4.2 Design of connections, hand calculation

Hand calculations were made for slotted-in steel plates, external steel plates, external timber plates and glued-in rods.

The first step of designing the slotted-in steel connections was hand calculations made in PTC Mathcad, see Appendix A.1. The calculations were made general in order to easily vary different parameters such as dimensions of the beam, thickness of the steel plate, number of steel plates, timber thicknesses, number of fasteners, diameter of the fastener and arrangement of the fasteners. This was an iterative process, where a number of combinations of these parameters were tested in order to analyse which parameters that affected the capacity the most and also get the most suitable connection.

The load-bearing capacity of the connection was calculated by the failure modes in Section 2.6.8. In Swedish Wood (2016d) detailed equations for designs with up to five slotted-in steel plates are listed. Based on these equations, a general equation for multiple steel plates could be created. The calculations described in (Swedish Wood, 2016d) are divided into two parts, one for the external shear planes, $R_{k,lateral}$ and one for the internal shear planes, $R_{k,centre}$. The number of external shear planes are always two since these are the outer shear planes on the outer steel plates. The number of internal shear planes on the other hand depends on the number of steel plates. Each steel plate has two shear planes, where the two outer plates has one internal and one external shear plane each and the inner steel plates has two internal shear planes each. The number of internal shear planes are the number of steel plates minus one, times two. A general equation for the failure modes can therefore be calculated as Equation 4.1 - 4.3. The calculation of the capacity gave a characteristic value which then were converted to a design value according to the Equation 2.1.

$$R_{k,centre} = (n_p - 1) \cdot (2 \cdot 1.15 \cdot \sqrt{2} \cdot \sqrt{2 \cdot M_{y,Rk} \cdot f_{h,k} \cdot d}) \quad (4.1)$$

where

n_p = number of steel plates

$$R_{k,lateral} = 2 \cdot \begin{cases} f_{h,k} \cdot d \cdot t_1 \cdot \left(\sqrt{2 + \frac{4 \cdot M_{y,Rk}}{f_{h,k} \cdot d \cdot t_1^2}} - 1 \right) & \text{if } \sqrt{2} \cdot \sqrt{\frac{M_{y,k}}{f_{h,k} \cdot d}} < t_1 \leq 1.15 \cdot 4 \cdot \sqrt{\frac{M_{y,k}}{f_{h,k} \cdot d}} \\ 1.15 \cdot \sqrt{2} \cdot \sqrt{2 \cdot M_{y,Rk} \cdot f_{h,k} \cdot d} & \text{if } t_1 \geq 1.15 \cdot 4 \cdot \sqrt{\frac{M_{y,k}}{f_{h,k} \cdot d}} \end{cases} \quad (4.2)$$

$$R_{v,k} = R_{k,centre} + R_{k,lateral} \quad (4.3)$$

In order for these equations to be accurate, requirements of the timber member thickness have to be fulfilled. To achieve the minimum distances between the outer plates and the edge, t_1 , requirement in Equation 2.63 should be used. Additionally, the requirement for spacing between plates, t_2 , which can be found in in Equation 2.64, should be fulfilled.

For the designs where the maximum number of steel plates were not used, t_1 was set to fulfill the minimum requirement and t_2 was calculated to get the steel plates evenly distributed over the beam, see equation 4.4. Afterwards, t_2 was controlled by the requirement in Equation 2.64 to ensure that the minimum value was fulfilled.

$$t_2 = \frac{b_t - 2 \cdot t_1 - t \cdot n_p}{n_p - 1} \quad (4.4)$$

where

t = thickness of steel plate t_1 = distance to edge

t_2 = distance between steel plates

t_b = beam thickness

n_p = number of plates

In order to calculate the capacity of the connection, several checks were done. The axial load was calculated according to the equations in Section 2.6.5 and the calculation for the yield moment of the fastener was made pursuant to Section 2.6.4 and Equation 2.6. The risk of block shear failure was checked by the Equations in Section 2.6.6.

The type of fastener was chosen to be bolts, since this gives the largest distances, specially relevant for a_2 . Although, in the continuation the fasteners will be referred to as dowels since they are of dowel-type fastener and dowel is a common name to describe fasteners such as nails, steel dowels and bolts (Swedish Wood, 2016a). However, it is important to notice that there is a difference between the calculations for bolts and regular dowels, namely the risk of rope effect which has to be considered for bolts but not for dowels. The spacing between the fasteners and distances between fasteners and end/edge were calculated according to Table 2.2. However, the distance to edge, a_4 , was adjusted to the width of the beam so that the same distance was used at both edges in order to have symmetry in the connection. The calculated distance a_4 was then checked to fulfill the minimum requirement according to the Table 2.2. The number of fasteners was calculated by the effective number of fasteners, n_{ef} , according to the Equation 2.68.

It is preferable to have as short steel plate as possible to minimize the amount of steel in the connection and also to make sure that it is not longer than the timber. The width of the beam should therefore be as utilized as possible. For explanation of length and width, see Figure 4.1. Hence, the maximum amount of fasteners was most often placed in the width of the plate in order to have minimum number of rows of fasteners along the length of the plate. Although in some cases, the number of maximum fasteners in the width was relatively high and the number of rows thereby got very small, the fasteners were distributed more evenly instead of using the full width.

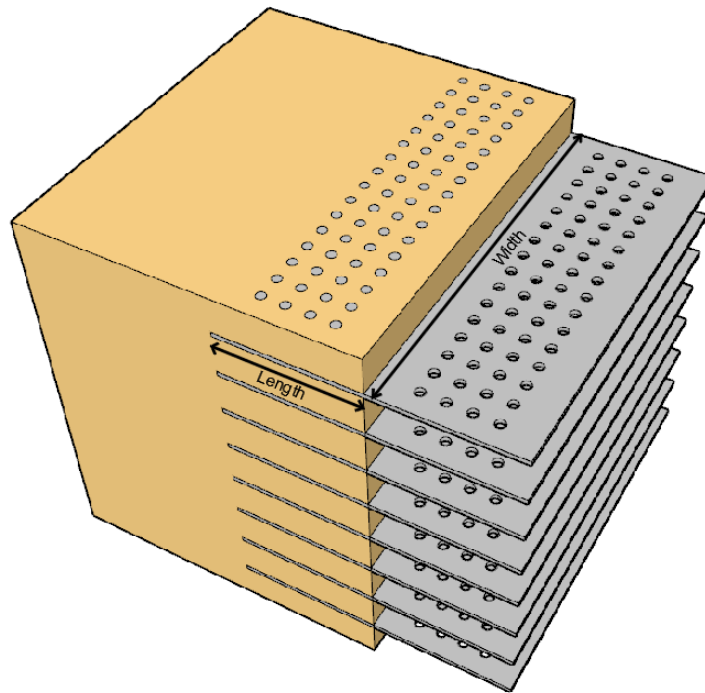

Figure 4.1: Slotted-in steel plate connection with the length and width of the plate explained.

In order to determine the capacity and compare the designs, the utilization ratio for resistance to failure modes and the block shear failure was presented in the calculations. The utilization ratio is a quota between the applied load and the capacity (Al-Emrani et al., 2013). This gives a percentage that represents the efficiency of the design, in this case the design of the connection. If the capacity of the connection is lower than the applied load, the utilization ratio gives a value above 100% and if the capacity of the connection is larger than the applied load a value between 0% and 100% is given. A utilization ratio just below 100% is often optimal since this means that the connection is almost fully utilized. For residential buildings, a utilization above 90% is often requested (Al-Emrani et al., 2013).

To find the total stiffness of a connection with slotted-in steel plates, the individual stiffness of every dowel, K_{ser} , was calculated using Equation 2.71. K_{ser} is the slip modulus in SLS load combination and since most of the analysis was made in ULS, the final slip modulus K_u was also calculated, according to Equation 2.72. This was later used as input in the FE-analysis described in Section 4.3.

In order to further evaluate and analyse the designs of the connection, five different alternatives for the largest beam were chosen for the next step, FE-analysis in FEM-design. The five designs differ in number of plates, number of fasteners, thickness of steel plate and length of the plate. After the first FE-analysis was made, relations between different parameters and stiffness were studied and lastly redesigned connections were made in order to optimize the stiffness. This was an iterative process to find which parameters that would increase the stiffness. For a more detailed explanation of this, see Chapter 4.4.

For the redesigned connections, the amount of steel was calculated for every connection in order to do a comparison. For example, one connection might have high stiffness but uses more steel than the other designs and this aspect was regarded in the evaluation process. The steel amount was found by calculating the volume of the steel plates and the volume of the dowels used in the connections. The volume of the timber member in the connection was calculated by subtracting the volume of the steel from the volume of an intact timber beam with length 1.5 m.

To do a verification of the method for calculating the stiffness determined in this study, a comparison with the stiffness of a continuous beam was done. Two beams that are connected with a joint would most probably have lower stiffness than a continuous beam with the same length as the two beams together. The verification was done for connection type A, the first designed connection. The stiffness of the continuous beam was calculated as Equation 4.5

$$K_{beam} = \frac{E \cdot A_c}{l_b} \quad (4.5)$$

where

K_{beam} = stiffness for the continuous beam

E = elastic modulus of the timber

A_c = area of the intact timber cross-section of the beam

l_b = length of the beam

For the stiffness of the beam including the connection, the elements were calculated as a serial coupling where one part is the stiffness of the connection and one part is the stiffness of rest of the timber beam.

$$\frac{1}{K_{bc}} = \frac{1}{K_{tot}} + \frac{1}{\frac{E \cdot A_c}{l_{bc}}} \quad (4.6)$$

$$l_{bc} = l_b - l_c \quad (4.7)$$

where

K_{bc} = total stiffness for the beam with connection

K_{tot} = stiffness for the connection

l_{bc} = length of the beam without the connection

l_c = length of the connection

To do the comparison, a quota between the stiffness for a continuous beam and the stiffness for the beam with the connection was given. This quota should be below 100%, since this means that the continuous beam has higher stiffness, and preferable not close to 0% since this means that the stiffness of the connection is very low. Besides from this, it is hard to know exactly which range of ratio that should be assumed to be accepted and should be discussed. This is a simple verification to get an indication if this method of determining the stiffness is reasonable or not. Furthermore, a better verification of the stiffness should be done if this method should be used for calculation of an exact value of the connection stiffness. Although in this

study, the calculated stiffnesses are compared with each other to see the behaviour and the variation in stiffness, not to get an exact value. Therefore, this verification were assumed to be sufficient for this thesis.

Besides from the slotted-in steel plate connections, hand calculations of connections with external steel plates and external timber plates were made, see Appendix A.2 and A.3. The hand calculations were made almost similar to the ones for slotted-in steel plates although the equations for the resistance to failure modes were different. For external steel plates, the equations under External steel plates in Section 2.6.8 were used and for external timber plates were the equations under Failure modes, double shear in Section 2.6.7 applied. Due to insufficient capacity, further analysis were not conducted with these connections.

Furthermore, hand calculations for connections with glued-in rods were conducted, see Appendix A.4. For this design, the equations in Section 2.6.9 were used to calculate the load-bearing capacity for rods in tension and also the withdrawal capacity of the timber. The minimum distances were also calculated together with a check that the required amount of rods can take place in the timber member.

Although the load-bearing capacity of the glued-in rods were sufficient, this type of connection was not further analysed due to a couple of reasons. There are lacking information about glued-in rods and it is especially hard to find instructions on how to calculate the stiffness. This topic is still under research and there is yet some uncertainties on how to do this. Also, there is more thorough research on slotted-in steel connections and more information about the stiffness. Moreover, slotted-in steel plates are known to be used in tall buildings, for example in the worlds tallest timber structure, Mjøstårnet (Abrahamsen, 2017). Additionally, slotted-in steel connection have more parameters that can be varied and therefore assumed to be more suitable for investigation on how to increase the stiffness of a building. Slotted-in steel plates was therefore chosen for the next step of the analysis.

4.3 Analysis of connection stiffnesses

A number of FE-analyses were made in the program FEM-design in order to investigate the stiffness of the different alternatives of the slotted-in steel plate connection, see Appendix A.5. The FE-model was simplified to only one timber plate and one connecting steel plate, instead of modelling the entire connection with several slotted-in steel plates. Furthermore, the plates were not modelled above each other, like the actual connection, since this can cause problems with incorrect rotational stiffness. To avoid this obstacle, both plates were modelled side by side, with point connections between, see Figure 4.2. This was assumed to be accurate since the point connection in FEM-design does not consider the placement of the points, only the stiffness between the points. Every point connection represents one dowel, both in placement and stiffness. For almost all designs, the analyses were made with ULS load combination and the stiffness for the point connection was thus set to the calculated stiffness K_u , slip modulus in ULS.

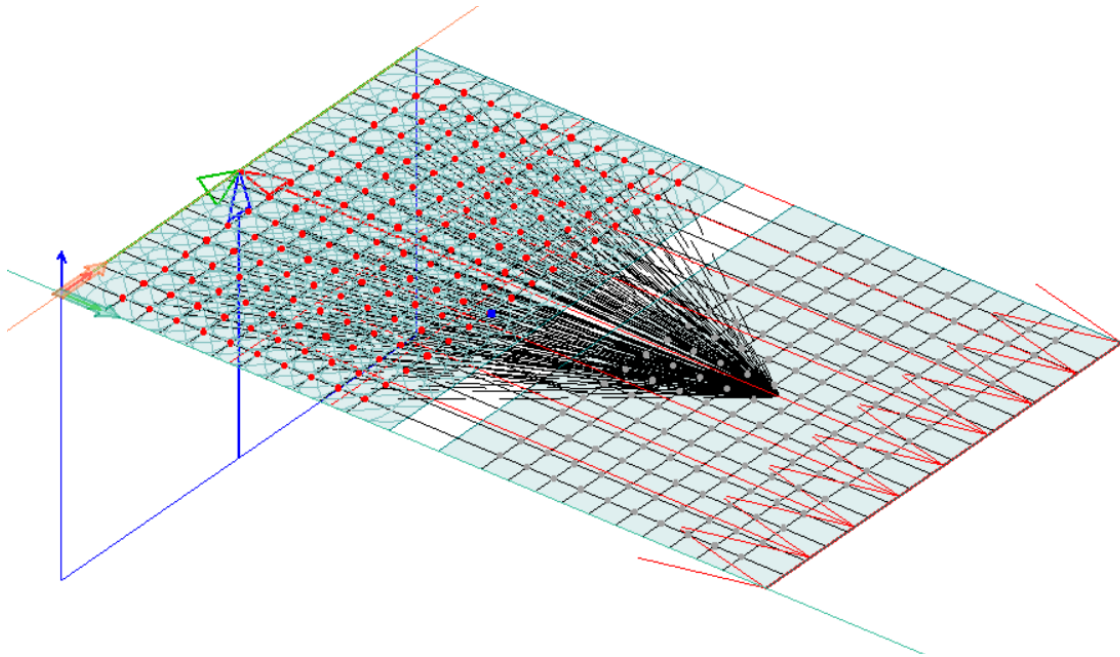

Figure 4.2: Example if a connection modelled in FEM-design.

Both the steel plate and the timber beam were modelled as plane plates with the dimensions according to the designed steel plate. This means that only a part of the timber beam was modelled in the program which was considered accurate since the connection stiffness is not dependent on the length of the timber beam. A line-support was placed at the end of the timber plate as simply supported and represents the rest of the beam. Two analyses were made for each design, one where the timber had thickness t_1 , i.e the distance between the steel plate and the edge, and one where the timber member had thickness t_2 , the distance between the steel plates. The reason for this was to be able to sum up the stiffnesses for the different parts to get the stiffness for the entire connection.

Furthermore, a line load was placed at the end of the steel plate, in tension, parallel to the direction of the plate, see the red arrows in Figure 4.2. The applied load was adjusted depending on the number of steel plates, since the model only considers one steel plate. So if the entire connection consisted of two steel plates, the applied load is divided by two. The settings for the load combination was ultimate limit state.

The maximum deformation of the model was extracted from the analysis and the stiffness for this part of the connection was then calculated due to the Equation 4.8:

$$F = k \cdot x \quad (4.8)$$

where

F = force [N]

k = stiffness [N/mm]

x = deformation [mm]

The total stiffness for one steel plate connected to one timber plate could in that way be calculated. Since all the studied connections have more than one slotted-in steel plate, the stiffness for the entire connection was summed up by adding the stiffnesses from the different parts, according to Equation 4.9.

$$K_{tot} = 2 \cdot k_1 + (n_p - 2) \cdot k_2 \quad (4.9)$$

where

K_{tot} = total stiffness for the entire connection

k_1 = stiffness for one steel plate and one timber member with thickness t_1

k_2 = stiffness for one steel plate and one timber member with thickness t_2

n_p = number of steel plates

When finding the displacement in a structure the serviceability limit state is most often considered. In this case though, the ultimate limit state is used for comparison of connections stiffnesses. The reason for this is that the ULS was used previously in the analysis and also because the main purpose of calculating the deflections and stiffnesses was the comparison between different designs of connections. It will therefore be hard to fulfill the often used deflection limit for tall buildings of $H/500$ since that limit is used for SLS.

Calculations of the deformation were however conducted with SLS load combination for the final design in order to ensure that this design fulfills the requirement. To find the deflection in SLS load combination, the same procedure as for ULS load combination was used although some changes were applied. The maximum normal force for SLS load combination found from the Grasshopper model was used and the settings in FEM-design for load combination were changed from Ultimate limit state to Serviceability - characteristic limit state and k_{def} was therefore set to two. Additionally, K_{ser} was used for the connection stiffness instead of K_u since K_{ser} is the slip modulus for SLS.

The total stiffness of the connection was introduced in the Grasshopper model of the whole building where a maximum displacement could be determined for the different connection types. In previous studies, the joints in the Grasshopper model were set to fixed or pinned. To change the stiffness, a joint-module was added. The joint-module made it possible to change both the translational and rotational stiffness to a chosen number instead of fully fixed or zero. The translational stiffness for each joint was therefore set to the total stiffness calculated from the FE-model and hand calculations and the rotational stiffness was set to zero. The maximum deformation of the building could then be collected from the model.

4.4 Optimization of connections

The first five alternatives of the slotted-in steel connection were designed to reach the resistance to failure modes and block shear failure. However, the analysis of the connections in FEM-design and Grasshopper gave relatively low stiffnesses and high displacements. The connections were therefore redesigned in order to get a

connection with higher stiffness. Accordingly, the parameters affecting the stiffness were investigated to get an understanding about which improvements that should be done to the design in order to increase the stiffness. The following parameters and their effect on the stiffness were studied as well as the stiffness effect on displacement:

- Effect of number of dowels
- Effect of dowel dimension
- Effect of number of steel plates
- Effect of steel plate thickness
- Effect of distance between steel plates

Tables and graphs were established for each of the above mentioned analysis and can be seen in Section 5.5.

The relation between the total displacement and the connection stiffness was studied to see the behaviour and get an estimation of how high stiffness that was requested. The stiffness of one of the connections was used as an initial value and this value was then decreased and increased between 25-300 % to see the variations in displacement. The analysis was done in the Grasshopper model where the translational stiffness was changed in the Joint-module in the same way as in the first analyses. The result was collected in a table and plotted as a graph to see the behaviour and possible convergence, i.e a value where an increased stiffness does not decrease the displacement noticeably.

The effect of number of dowels was also considered. This was done by studying the same connection and keeping the other parameters constant except the rows of fasteners, which were increased one row at the time. The number of fastener along the width of the connection was kept constant as well as the number of plates, distances, thickness of steel plate and the dimension of dowel. The length of the connection was extended with one row at the time. The study was done in FEM-design as previously described in Section 4.3. This gave a displacement for the model and the stiffness for the entire connection could then be calculated.

The dowel dimension's effect on the stiffness was studied too. Dimensions between 10-28 mm were tested. When changing the dimension of the dowel, the number of dowels is automatically changed since the needed amount of dowels is dependent on the size. The number of dowels was therefore set to the minimum value for each dimension to fulfill the capacity. The number of plates was kept constant to four and the thicknesses t_1 and t_2 were also kept constant for all the studies except for the model with dowel dimension 28 mm since this required larger t_2 . The fact that several parameters had to be changed could make it difficult to analyse the affect of changing the dowel dimension. The analyses were conducted in FEM-design where the model were changed for each dowel dimension.

Furthermore, an analysis of the effect of number of steel plates was done. The thickness of the steel plate, the dowel dimension and the number of fasteners was kept constant and the number of plates and timber thicknesses varied. The analyses were tested with three, four, five, six and seven steel plates since these are the only

numbers that fulfilled the requirement of timber thicknesses for dowel dimension 16 mm.

The influence of the thickness of the steel plates was also investigated. The connection type was kept constant and the steel thickness and the timber thickness were changed, since the timber thicknesses are dependent on the steel thickness due to constant beam thickness. The steel thickness tested varied between 8-20 mm.

Lastly, the effect of changing the timber thicknesses, i.e spacing between steel plates and distance between edge and steel plate, was evaluated. Both the distances were increased and decreased to see how this affects the stiffness.

These analyses resulted in a better understanding of what parameters that should be changed to increase the stiffness of the connection. As a result of this, eight new and improved connections was designed and further analysed. The same procedures in hand calculations, FEM-design and Grasshopper were done as before to analyse the new connections.

In order to choose one suitable connection from the eight improved designs, a weighting matrix and a grading matrix were developed. A challenge with choosing one suitable connection from the improved connections was that the different designs have different advantages and it was difficult to compare and prioritise them. Consequently, a grading matrix with an associated weighting matrix were constructed to be able to choose. In a weighting matrix, the included parameters were weighted against each other to get the parameters in a ranked order and see which parameters that are most important. This resulted in a weighting factor for every parameter which are values describing how important the parameters are in comparison to each other. These weighting factors are then used in the grading matrix. The alternative designs are given a grade between 1-5 in each category. The grades are then multiplied with the weighting factor from the weighting matrix before being summed up to get total points for every design. In this way, a final design could be determined which have high grades in the categories that were weighted as the most important and therefore is optimal for this structure.

5

Connection analyses and results

In this chapter the results from the different performed analyses are described. Also, some conclusions about the results and how they affected the further investigations and choices are presented.

5.1 Forces

The maximum forces extracted from the Grasshopper model for the five different beam dimensions are shown in Table 5.1. The maximum force was found at the bottom floor of the building and the force is thereafter decreasing with the height of the building. The SLS force was only used for a deformation check and was therefore only reviewed for the first floor, where the maximum value occurs.

Table 5.1: Truss dimensions and maximum normal forces for the different floors.

Floor	Truss dimension [mm]	Maximum force ULS [kN]	Maximum force SLS [kN]
1	850x850	5129	4873
11	700x700	3860	
32	550x550	1714	
44	400x400	759	
53	250x250	364	

The design of the connections will be performed for the worst scenario, which will appear where the largest force acts in the structure. To be sure that the worst case have been accounted for the same maximum force have been assumed both for tension and compression, a conservative simplification.

5.2 Connection type

Calculations and analyses have been performed for connections with external steel plates, external timber plates, glued-in rods and slotted-in steel plates. The results of the analyses are presented in this chapter. An evaluation was made in order to choose one of these four alternatives for further investigations.

5.2.1 External plates

Calculations have been performed for connections with external steel and external timber plates. For both the connection types a number of designs were tested with varying plate thickness and varying dowel dimension. The results can be seen in Tables 5.2 and 5.3.

Table 5.2: Properties of connections with external steel plates.

t [mm]	d [mm]	t_t [mm]	b_t [mm]	l_p [mm]	$n_{b,max}$	$n_{l,max}$	n	U_{fast} [%]
10	10	850	850	1625	27	30	810	153.7
10	16	850	850	1625	16	18	288	233.7
10	20	850	850	1625	13	14	182	273.0
10	24	850	850	1625	10	11	110	325.8
10	28	850	850	1625	9	9	81	337.6
20	10	850	850	1625	27	30	810	153.7
20	16	850	850	1625	16	18	288	182.4
20	20	850	850	1625	13	14	182	193.0
20	24	850	850	1625	10	11	110	255.3
20	28	850	850	1625	9	9	81	286.7

where

t = thickness of the steel plate

d = diameter of the fastener

t_t = thickness of the timber beam

b_t = width of the timber beam

l_p = length of the plate

$n_{b,max}$ = maximum number of fasteners along the width of the plate

$n_{l,max}$ = maximum number of fasteners along the length

n = total number of fasteners

U_{fast} = utilization ratio with regard to shear failure of the fastener

As can be seen in Table 5.2, none of the designs with external steel plates has a utilization ratio under 100 %, which means that the capacities of the connections are lower than the applied load and are therefore insufficient. These designs used the maximum number of dowels in both the width and the length of the plate, which are limited by the requirements of distances between fasteners and between fasteners and end or edge. This means that the maximum number of dowels that could fit in the steel plate was used for the calculations and the capacity was still not enough. Due to this, further analyses of this type of connection were not conducted.

The result in Table 5.3 clearly shows that a connection with external timber plates was not an alternative for this structure since the utilization ratio was much higher than 100 %. Larger timber thickness increases the capacity for almost all the designs, except for the design with dowel dimension 10 mm where it is constant. The reason for this can be that different failure modes appear for the different designs.

Table 5.3: Properties of connections with external timber plates.

t [mm]	d [mm]	t_t [mm]	b_t [mm]	l_p [mm]	$n_{b,max}$	$n_{l,max}$	n	U_{fast} [%]
20	10	850	850	1625	27	30	810	334.5
20	16	850	850	1625	16	18	288	514.0
20	20	850	850	1625	13	14	182	666.3
20	24	850	850	1625	10	11	110	944.0
20	28	850	850	1625	9	9	81	1136.8
40	10	850	850	1625	27	30	810	283.8
40	16	850	850	1625	16	18	288	383.2
40	20	850	850	1625	13	14	182	417.5
40	24	850	850	1625	10	11	110	503.7
40	28	850	850	1625	9	9	81	568.4

One problem with these connections were that the number of fasteners needed to fulfill the capacity could not take place in the plate, the area of the plate was too small. Even if the length of the plate was set to half the timber beam, the required number of fasteners could still not fit and additionally, other problems may arise with such a long plate. Practically, it is the maximum length of the plate since a longer plate would meet the plate for the next joint.

Other conclusions can be made from the results. For example, the utilization ratios are increasing with increased dimension of the dowel. This means that the capacity is decreasing with larger dowel dimensions. Also, a larger dimension of the dowel implies larger distances which also affects the capacity of the connection. Furthermore, the number of fasteners that can fit on the plate is not dependent on the thickness of the plate, only the dimension of the dowel. The capacity is clearly increasing with the thickness of the plate, since the utilization ratios are lower for thicker plates.

5.2.2 Rods

Calculations for glued-in rods were done for different dimensions of the rod. As can be seen in Table 5.4, the load-bearing capacity of the rods and the withdrawal strength in the timber were both sufficient to resist the applied load. It can also be seen that the withdrawal strength in the timber was the most critical failure mode.

Table 5.4: Properties of glued-in rod connections.

d [mm]	t_t [mm]	b_t [mm]	l_i [mm]	n_b	n_l	n	U_{rod} [%]	U_{timber} [%]
10	850	850	450	5	6	30	24.2	99.9
12	850	850	450	5	5	25	25.7	94.6
16	850	850	450	5	4	20	24.9	83.4
20	850	850	450	4	4	16	24.2	78.2

where

d = diameter of the fastener

t_t = thickness of the timber beam

- b_t = width of the timber beam
- l_i = length of glued-in part of the rod
- n_b = number of fasteners along the width of the plate
- n_l = number of fasteners along the length of the plate
- n = total number of fasteners
- U_{rod} = utilization ratio with regard to the capacity of the rod
- U_{timber} = utilization ratio with regard to the withdrawal capacity of the timber

The calculation was performed with entire rows and columns of rods, which in some cases lead to more rods than needed. For instance, the design with dowel dimension 16 mm needed 13 rods to fulfill the capacity. Although, since full rows were used, the distribution was $4 \cdot 4$ which is 16 dowels. The utilization ratio was therefore lower than if the minimum amount of fastener was used.

As already mentioned, this connection was not further analysed because of a number of reasons, for example the complexity in calculating the stiffness for glued-in rods and the variation of parameters in the slotted-in steel plate connection. More on this in Section 4.2.

5.2.3 Slotted-in steel plate

Out of the many different versions of the slotted-in steel plate connection that were developed five of them, from now on called connection A, B, C, D and E, were chosen for further analyses. The properties of the different connection versions are presented in Table 5.5 and Figure 5.1. It can be seen that all the alternatives have been designed to not exceed a utilization of 100 %, thus the amount of fasteners have been chosen to a number that reaches the highest possible utilization ratio. For all the cases, the fastener failure turned out to be more critical than the block shear failure.

The number of fasteners along the width of the steel plate has been set to the maximum number possible with the given minimum spacing and edge distances. Consequently the number of fasteners along the width of the plate is dependent on the dowel diameter since the edge distance is dependent on the diameter, see Table 2.3. The number of fasteners along the length of the plate has been chosen to the minimum number that fulfills the required load-bearing capacity.

The number of slotted-in steel plates is limited by the minimum values of t_1 and t_2 , described in Section 2.6.12. Since these are dependent on the dowel diameter the maximum number of plates will vary with changed dowel dimensions.

Table 5.5: Properties of slotted-in steel plate connections A-E.

	t [mm]	d [mm]	t_1 [mm]	t_2 [mm]	n_p	n_b	n_l	n	l_p [mm]	U_{block} [%]	U_{fast} [%]
A	10	10	24	78	10	11	5	55	360	44.7	98.4
B	10	16	36	118	7	12	3	36	384	43.0	92.2
C	10	24	200	210	3	8	5	40	816	42.6	97.6
D	20	24	200	195	3	8	5	40	816	42.4	97.6
E	10	24	150	170	4	8	4	32	696	43.1	91.7

where

t = thickness of the steel plate

d = diameter of the fastener

t_1 = distance from the steel plate to the edge of the beam

t_2 = distance between the steel plates

n_p = number of steel plates

n_b = number of fasteners along the width of the plate

n_l = number of fasteners along the length of the plate

n = total number of fasteners

l_p = length of the plate

U_{block} = utilization ratio with regard to block shear failure

U_{fast} = utilization ratio with regard to shear failure of the fastener

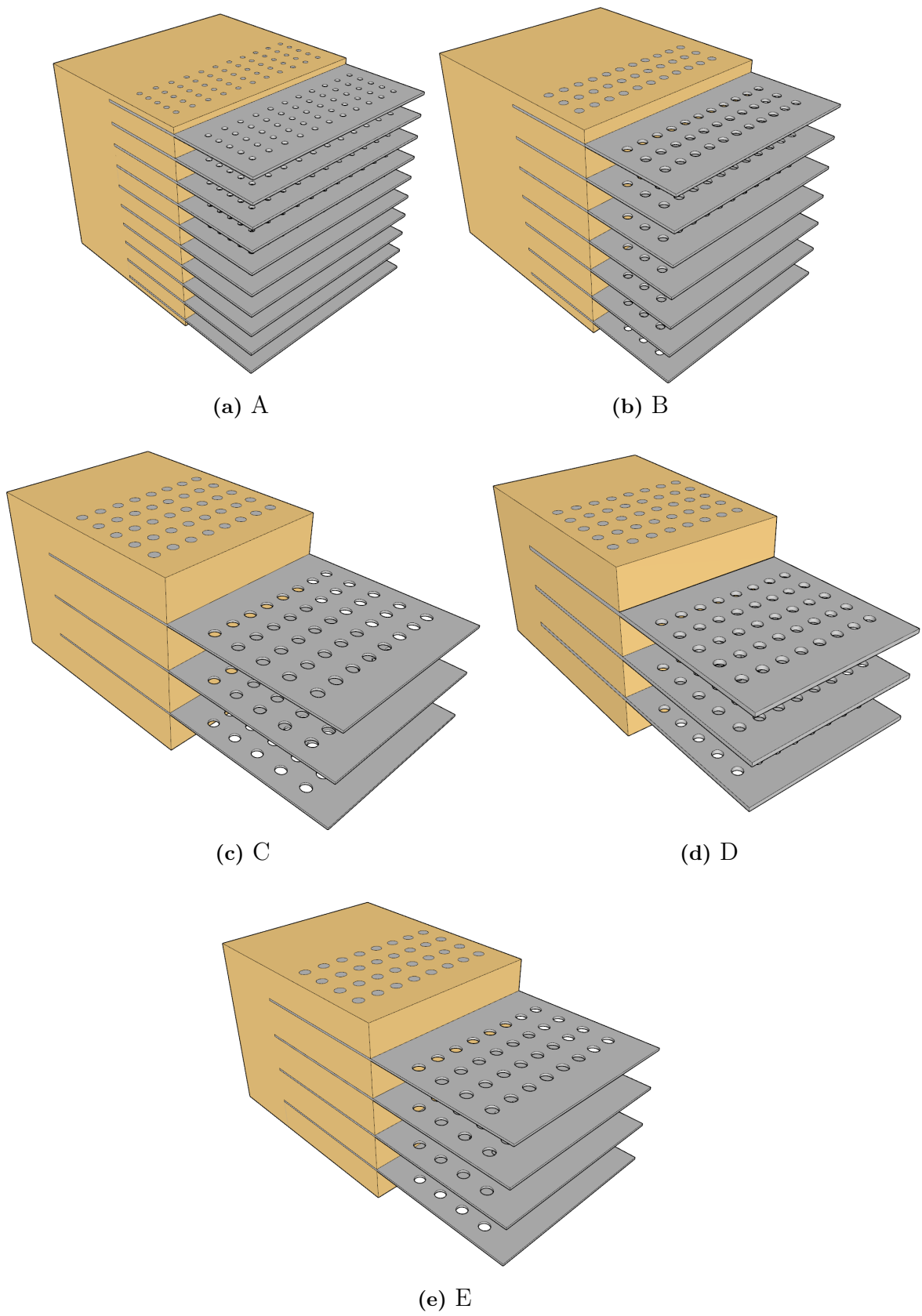

Figure 5.1: Connections A-E.

5.2.4 Chosen connection type

The result showed that the external steel plate and external timber plate have insufficient capacity and were therefore not qualified for further investigations. Both glued-in rods and slotted-in steel plates showed sufficient load-bearing capacity but when comparing these two alternatives, the slotted-in steel plate connection was assumed to be more appropriate for a stiffness study and was therefore chosen for further analyses.

5.3 Connection stiffness and displacement

In Table 5.6 stiffnesses and maximum displacement of the building for connections A-E are presented, calculated according to Section 4.3. It is clear that the displacements are very dependent of the connection stiffnesses as a higher total slip modulus gives smaller total deflections and vice versa.

Table 5.6: Stiffness and displacement for connections A-E.

	K_u [kN/m]	n	K_{tot} [kN/m]	u [mm]
A	6096	55	3251000	468.9
B	9754	36	2415000	522.1
C	14630	40	1603000	612.2
D	14630	40	1686000	600.1
E	14630	32	1778000	587.6

where

K_u = slip modulus for one fastener in ULS

n = total number of fasteners

K_{tot} = total slip modulus for the whole connection

u = maximum total displacement

K_u is dependent on the timber density and the diameter of the fastener and since C, D and E have the same dowel dimension the value for K_u also is the same. The other differences of the connections (plate thickness, number of plates and number of fasteners) makes the total slip modulus K_{tot} vary and therefore also results in different displacements for the structure.

5.4 Verification of stiffness

To check that the calculated stiffnesses are reasonable a simple verification was made. The stiffness of a beam with a slotted-in steel plate connection was compared with the stiffness of a continuous beam, see description in Section 4.2. The verification was done on a beam with connection A and the results of the verification are presented in Table 5.7. The difference between the calculated stiffnesses in Table 5.7 and the previously calculated stiffnesses for connection A-E, in Table 5.6, is that K_{beam} and

K_{bc} takes a whole beam into account while K_{tot} only considers a part of the beam with the length of the connection.

Table 5.7: Verification of stiffness for connection A.

K_{beam} [kN/m]	K_{bc} [kN/m]	ratio
2512000	1511000	0.602

where

K_{beam} = stiffness for the continuous beam
 K_{bc} = stiffness for the beam with connection
 ratio = ratio between the two stiffnesses

The results shows that the stiffness of the continuous beam is higher than the stiffness of the beam with connection A and that is considered as a reasonable result. The stiffness of the beam with connection is about 60 % of the stiffness of the continuous beam.

5.5 Effect on stiffness

Some studies were conducted regarding how the total stiffness of the connection is affected by different parameters to see what changes that influences the stiffness the most. This could help in the process of prioritising what improvements to implement to reach a higher connection stiffness and smaller displacements of the structure.

Generally, a connection with small amounts of steel was aimed for. The reason why less steel should be used is that steel is not only more expensive than timber but also has a larger environmental impact (Ramboll, 2022). The amount of steel should therefore be considered when investigating different connections. The amount of steel in one connection might not change that much between the different versions but due to the size of this building and the large number of connections the total amount of steel in the building will increase a lot if the connection contains much steel.

5.5.1 Effect of changing stiffness

An analyse was performed to investigate how the displacements were affected by the connection stiffness. As a starting point and initial value the total stiffness for connection C of 1603000 kN/m was used. It is marked as 100 % in Table 5.8 and the stiffness was both increased and decreased compared to this value to see how large the changes of the displacements became. The stiffness was changed between 25 % and 300 % of the initial value. The displacement changes in percent compared to the initial value are also presented in Table 5.8. The connection stiffness versus displacement of the structure is plotted in Figure 5.2.

Table 5.8: Effect of changing the total stiffness of the connection. The initial values for connection C are marked with bold text.

K_{tot} [kN/m]	% of initial K_{tot}	u [mm]	% of initial u
400750	25	1020.5	167
801500	50	804.7	131
1202250	75	686.8	112
1603000	100	612.2	100
2003750	125	560.7	92
2404500	150	523.0	85
2805250	175	494.1	81
3206000	200	471.2	77
3606750	225	452.7	74
4007500	250	437.4	71
4809000	300	413.5	68

where

K_{tot} = total slip modulus for the whole connection

u = maximum total displacement

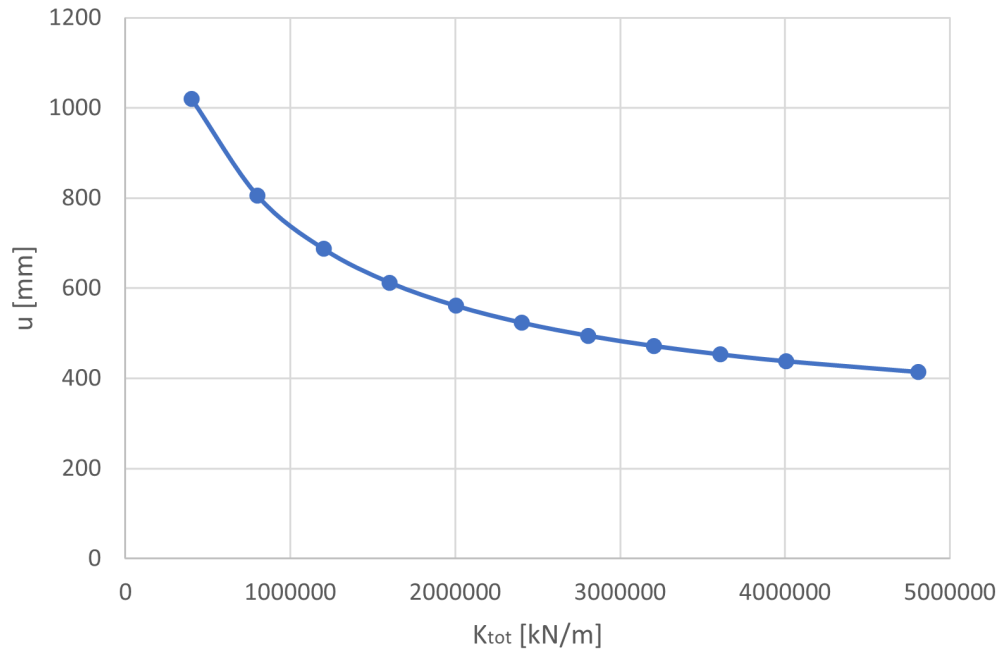
**Figure 5.2:** Displacement changes with varying stiffness.

In Figure 5.2 it becomes visible how the displacements changes with a varying stiffness. The larger the stiffness is the smaller the inclination of the curve becomes which means that the change of deflection decreases with larger stiffness. As a decreasing inclination of the curve was observed it could be stated that there, at some point, most likely not will be necessary to aim for a stiffer connection. When

the curve flattened it means that the deflection was no longer affected to the same extent. The conclusion was that a connection stiffness between 3000000-3500000 kN/m seems reasonable to aim for. Of course a higher stiffness is not negative but it will not give same decrease of deflection as earlier.

5.5.2 Effect of number of dowels

By changing the number of dowels in a slotted-in steel plate connection the effect on the stiffness of the connection was studied. The connection was changed by increasing and decreasing the number of fasteners along the length of the plate. The number of fasteners along the width of the plate was kept constant to the maximum value allowed with regard to the minimum distance between the dowels. This was done to make sure that the plate length is as small as possible as a connection with small amounts of steel was aimed for. Table 5.9 shows the properties for the analysed connection versions.

Table 5.9: Properties of connections with varying amount of dowels.

t [mm]	d [mm]	t_1 [mm]	t_2 [mm]	n_p	n_b	n_l	n	l_p [mm]	U_{block} [%]	U_{fast} [%]
10	24	150	170	4	8	4	32	696	41.4	91.7
10	24	150	170	4	8	5	40	816	41.4	75.1
10	24	150	170	4	8	6	48	936	41.4	63.7
10	24	150	170	4	8	7	56	1056	41.4	55.4
10	24	150	170	4	8	8	64	1176	41.4	49.2
10	24	150	170	4	8	9	72	1296	41.4	44.2
10	24	150	170	4	8	10	80	1416	41.4	40.2

where

t = thickness of the steel plate

d = diameter of the fastener

t_1 = distance from the steel plate to the edge of the beam

t_2 = distance between the steel plates

n_p = number of steel plates

n_b = number of fasteners along the width of the plate

n_l = number of fasteners along the length of the plate

n = total number of fasteners

l_p = length of the plate

U_{block} = utilization ratio with regard to block shear failure

U_{fast} = utilization ratio with regard to shear failure of the fastener

When the number of rows are increased by adding dowels it leads to an increased plate length. The steel plate length is limited by the beam length of 3.25 metres. This means that the plate can not be longer than approximately 1.5 metres to be able to fit in the beam. Preferably the plate will be shorter than that to decrease the amount of steel used in the connection.

Based on these new versions with varying amount of fasteners the stiffnesses were compared and the results are presented in Table 5.10 and Figure 5.3. To easier

be able to make a comparison of which parameters that has larger effect on the connection stiffness quotas between the stiffnesses of the different connection versions were calculated and are stated as *difference* in Table 5.10. The first connection is referred to as 1.000 and the quotas for the following connections were calculated by comparing the stiffness of the studied connection to the stiffness of the first connection.

Table 5.10: Stiffness and displacement for connections with varying amount of dowels.

K_u [kN/m]	n	K_{tot} [kN/m]	difference	u [mm]
14630	32	1778000	1.000	587.6
14630	40	2097000	1.179	550.9
14630	48	2365000	1.330	526.2
14630	56	2581000	1.452	509.3
14630	64	2752000	1.548	497.5
14630	72	2889000	1.625	488.9
14630	80	2982000	1.677	483.4

where

K_u = slip modulus for one fastener in ULS

n = total number of fasteners

K_{tot} = total slip modulus for the whole connection

u = maximum total displacement

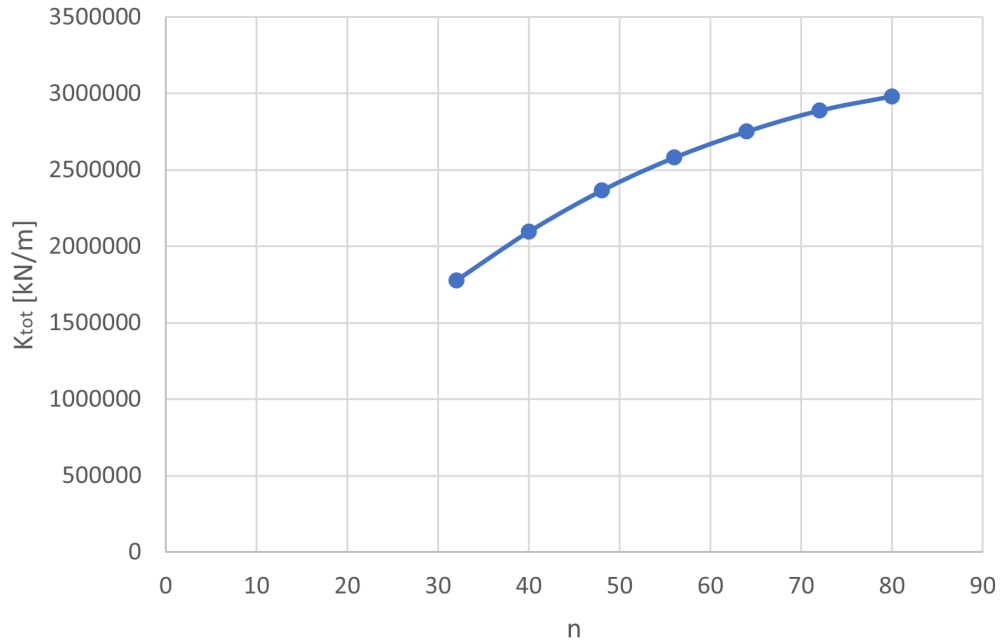

Figure 5.3: Change of stiffness with varying number of dowels.

K_u did not change for the different versions since they all had the same dimension of the dowels. The total stiffness K_{tot} was though, as expected, increased with the number of fasteners. As Table 5.10 shows, the stiffness increased with 67.7 % when the number of dowels were changed from 32 to 80, i.e. an increment of 48 dowels.

The increase of stiffness is largest in the beginning, for smaller n , to later diminish the more fasteners that are inserted. This means that the increase from 32 to 40 dowels have a larger effect on the stiffness than the increase from 72 to 80 dowels, even though both of them imply an increment of 8 dowels.

5.5.3 Effect of dowel dimension

There are many different dowel dimensions available. When studying how the dowel dimension affects the stiffness six different dimensions between 10 and 28 mm were chosen, see Table 5.11.

Table 5.11: Properties of connections with varying dowel dimensions.

t [mm]	d [mm]	t_1 [mm]	t_2 [mm]	n_p	n_b	n_l	n	l_p [mm]	U_{block} [%]	U_{fast} [%]
10	10	150	170	4	20	7	140	460	41.4	96.1
10	12	150	170	4	17	6	102	468	41.4	94.6
10	16	150	170	4	12	5	60	544	41.4	96.3
10	20	150	170	4	10	4	40	580	41.4	96.8
10	24	150	170	4	8	4	32	696	41.4	91.7
10	28	114	194	4	7	4	28	812	41.4	85.9

where

t = thickness of the steel plate

d = diameter of the fastener

t_1 = distance from the steel plate to the edge of the beam

t_2 = distance between the steel plates

n_p = number of steel plates

n_b = number of fasteners along the width of the plate

n_l = number of fasteners along the length of the plate

n = total number of fasteners

l_p = length of the plate

U_{block} = utilization ratio with regard to block shear failure

U_{fast} = utilization ratio with regard to shear failure of the fastener

Since the amount of dowels is very dependent on the dimensions of them it was decided that the number would be set to the minimum possible that still could resist the load. This means that the total number of fasteners varied a lot between the different connection versions. The relevance of the comparison might decrease because of this, since more than just one parameter was changed. Although, it was considered the best option since it would be very hard to find an amount that would be possible to use for all dowel dimensions, it would neither be realistic nor able to resist the applied load. This makes the utilization ratio of the fasteners for all connection versions quite high.

Another exception from the determined constant connection properties for this study was that the distances between the outer plates and the edges as well as the distance between the plates had to be modified for the last version of the connection. This, because the plate distances are dependent on the fastener dimension. For the 28 mm dowels the distance between the plates, that previously was set to 170 mm, turned out to be smaller than the minimum allowed value, it was therefore adjusted to fulfill the requirements.

The results from the stiffness analysis are presented in Table 5.12 and Figure 5.4.

Table 5.12: Stiffness and displacement for connections with varying dowel dimensions.

K_u [kN/m]	n	d [mm]	K_{tot} [kN/m]	difference	u [mm]
6096	140	10	3038000	1.000	480.2
7316	102	12	2479000	0.816	517.0
9754	60	16	2191000	0.721	541.7
12190	40	20	1884000	0.620	574.4
14630	32	24	1778000	0.586	587.6
17070	28	28	1765000	0.581	587.4

where

K_u = slip modulus for one fastener in ULS

n = total number of fasteners

d = diameter of the fastener

K_{tot} = total slip modulus for the whole connection

u = maximum total displacement

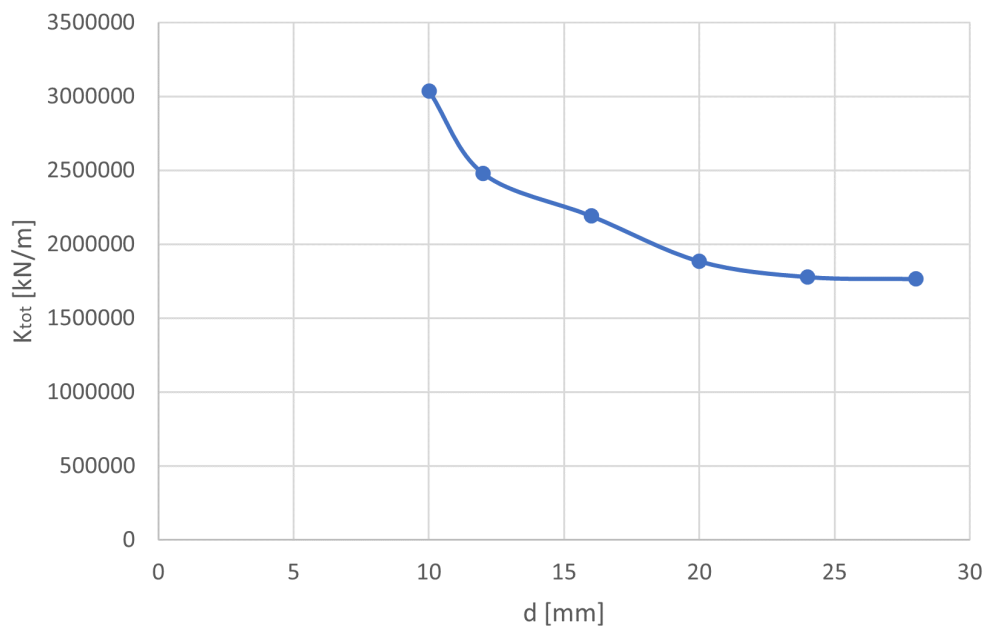

Figure 5.4: Change of stiffness with varying dowel dimensions.

For smaller dowel dimensions a quite significant decrease of stiffness can be seen between the points in Figure 5.4. For larger dimensions the change of stiffness is not as considerable and the curve is clearly flattened. Increasing the dowel dimension to larger than 20 mm could therefore be considered unnecessary because the effect on the stiffness is thereafter relatively small.

This investigation shows that increasing the dowel diameter leads to a decreased stiffness, which means that smaller dowel dimensions are preferable with regard to the stiffness. A result of using smaller dowel dimensions is that the amount of dowels will increase. Therefore, a balance between the amount of dowels and the dimension of them needs to be found. Too many dowels may not be reasonable and will also make it more complicated when it comes to production.

Some unexpected results can be identified in Figure 5.4. For a dowel of 16 mm the stiffness seems to be a bit higher than expected when looking at the graph, at that point it deviates from the expected curve shape. Between 24 mm and 28 mm there was an unpredicted increase of stiffness. A reason for these two unexpected results could be that the amount of fasteners has been adjusted to be able to carry the loads. The different versions are therefore not completely identical in terms of other properties than the dowel dimension. The changing amount of dowels can make the comparison a bit less accurate. Despite this, the conclusion that the stiffness decreases with an increasing dowel dimensions can be considered relevant.

5.5.4 Effect of number of steel plates

The number of slotted-in steel plates in the connection is as mentioned limited by the minimum spacing between the plate and the edge, t_1 , as well as the minimum spacing between the plates, t_2 . As both t_1 and t_2 are dependent on the dowel dimensions the maximum number of plates varies with the dowel dimension. This study was performed with 16 mm dowels and that gives a maximum of seven steel plates. The starting value was decided to be three and the number of plates was therefore varied between three and seven. For all connection properties, see Table 5.13.

Table 5.13: Properties of connections with varying amount of plates.

t [mm]	d [mm]	t_1 [mm]	t_2 [mm]	n_p	n_b	n_l	n	l_p [mm]	U_{block} [%]	U_{fast} [%]
10	16	200	210	3	12	7	84	704	40.9	94.8
10	16	150	170	4	12	7	84	704	41.4	71.1
10	16	130	135	5	12	7	84	704	41.9	56.9
10	16	100	118	6	12	7	84	704	42.4	48.4
10	16	48	114	7	12	7	84	704	43.0	42.9

where

t = thickness of the steel plate

d = diameter of the fastener

t_1 = distance from the steel plate to the edge of the beam

t_2 = distance between the steel plates

n_p = number of steel plates

$$\begin{aligned}
n_b &= \text{number of fasteners along the width of the plate} \\
n_l &= \text{number of fasteners along the length of the plate} \\
n &= \text{total number of fasteners} \\
l_p &= \text{length of the plate} \\
U_{block} &= \text{utilization ratio with regard to block shear failure} \\
U_{fast} &= \text{utilization ratio with regard to shear failure of the fastener}
\end{aligned}$$

When studying how the stiffness was affected by the number of steel plates the other connection parameters were kept constant. This means that the utilization of the fasteners was lower for the connections with larger number of plates than for the connections with smaller number of plates because fewer dowels were needed when additional plates were inserted. The number of fasteners were chosen to make sure that all the connection versions fulfilled the load-bearing requirement and was thereafter kept constant for all the connection versions to be able to make a fair comparison of how the stiffness was affected by the amount of steel plates.

The calculated stiffnesses and deformations for the connections with different amount of steel plates are presented in Table 5.14 and Figure 5.5.

Table 5.14: Stiffness and displacement for connections with varying amount of plates.

K_u [kN/m]	n	n_p	K_{tot} [kN/m]	difference	u [mm]
9754	84	3	2130000	1.000	547.6
9754	84	3	2784000	1.307	485.4
9754	84	3	3416000	1.604	461.0
9754	84	3	4015000	1.885	437.7
9754	84	3	4506000	2.115	421.6

where

$$\begin{aligned}
K_u &= \text{slip modulus for one fastener in ULS} \\
n &= \text{total number of fasteners} \\
n_p &= \text{number of steel plates} \\
K_{tot} &= \text{total slip modulus for the whole connection} \\
u &= \text{maximum total displacement}
\end{aligned}$$

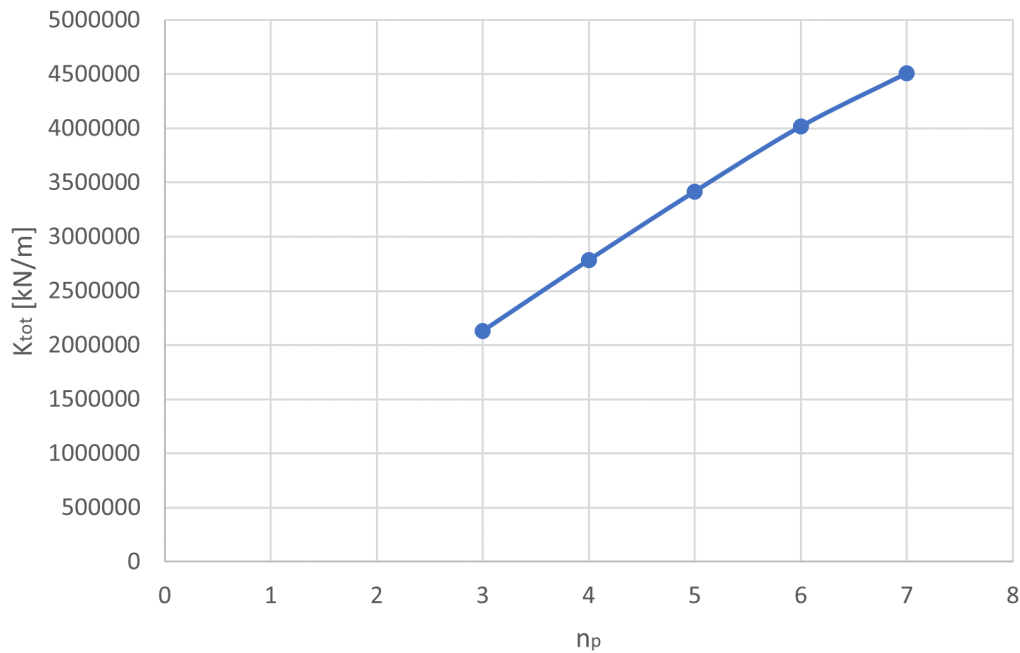

Figure 5.5: Change of stiffness with varying number of plates.

When comparing the connection with three plates with the one with seven plates the total stiffness of the connection was increased by about 112 %. It was therefore obvious that there was a distinct increase of stiffness when adding plates to the connection. This also influenced the total deflection a lot where large differences was observed between the five studied versions. It was therefore concluded to be more sufficient to have a larger number of steel plates and thus smaller distances for t_1 and t_2 .

From Figure 5.5 a linear relationship between n_p and K_{tot} was determined and it was assumed that the total stiffness had a constant linear increase with an increased amount of steel plates.

5.5.5 Effect of steel plate thickness

To see how the thickness of the slotted-in steel plates affects the stiffness of the structure the connection was modelled with five different plate thicknesses. The investigated connection contains four steel plates and when their thickness was changed it affected the distances between the plates. The modified versions with new thicknesses are presented in Table 5.15.

Table 5.15: Properties of connections with varying plate thickness.

t [mm]	d [mm]	t_1 [mm]	t_2 [mm]	n_p	n_b	n_l	n	l_p [mm]	U_{block} [%]	U_{fast} [%]
8	24	150	172.7	4	8	8	64	1176	41.0	49.2
10	24	150	170	4	8	8	64	1176	41.4	49.2
12	24	150	167.3	4	8	8	64	1176	41.8	49.2
15	24	150	163.3	4	8	8	64	1176	42.4	49.2
20	24	150	156.7	4	8	8	64	1176	43.5	49.2

where

t = thickness of the steel plate

d = diameter of the fastener

t_1 = distance from the steel plate to the edge of the beam

t_2 = distance between the steel plates

n_p = number of steel plates

n_b = number of fasteners along the width of the plate

n_l = number of fasteners along the length of the plate

n = total number of fasteners

l_p = length of the plate

U_{block} = utilization ratio with regard to block shear failure

U_{fast} = utilization ratio with regard to shear failure of the fastener

In Table 5.16 and Figure 5.6 the results from the investigation of how the stiffness is affected by the plate thickness are presented.

Table 5.16: Stiffness and displacement for connections with varying plate thickness.

K_u [kN/m]	n	t	K_{tot} [kN/m]	difference	u [mm]
14630	64	8	2651000	1.000	504.4
14630	64	10	2752000	1.038	497.5
14630	64	12	2823000	1.065	492.9
14630	64	15	2869000	1.082	490.1
14630	64	20	2970000	1.120	484.0

where

K_u = slip modulus for one fastener in ULS

n = total number of fasteners

t = thickness of the steel plates

K_{tot} = total slip modulus for the whole connection

u = maximum total displacement

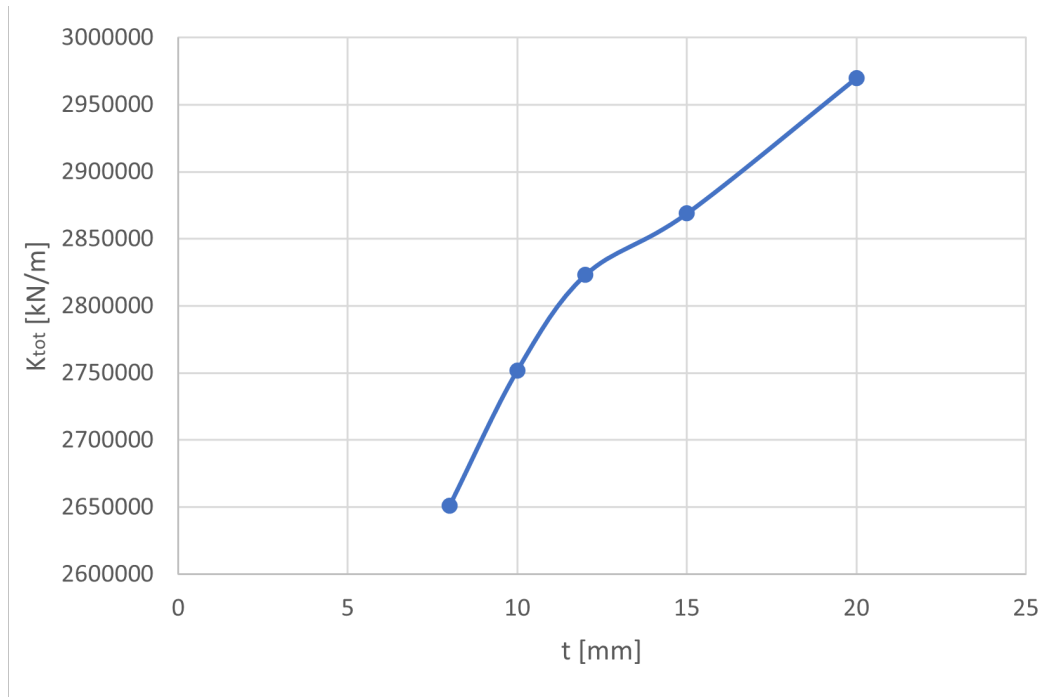

Figure 5.6: Change of stiffness with varying plate thickness.

The stiffness of the connection was increased with an increased plate thickness. As Table 5.16 demonstrates the change was between 3.8 to 12.0 %, which is relatively small compared to other adjustments. It can be concluded that increasing the steel plate thickness is a relatively ineffective approach to stiffen the connection.

The curve in Figure 5.6 has a quite unpredictable shape where the inclination is high in the beginning, then seems to wane in the middle to later increase again between the two last points. There is not an obvious reason for this but it could depend on the relatively small range on the y-axis due to the small changes of stiffness.

5.5.6 Effect of distance between steel plates

The distance between the outer steel plates and the edge of the beam as well as the distance between the steel plates can be varied as long as the minimum values according to Equation 2.63 and 2.64 are fulfilled. Since the beam has a definite thickness of 850 mm an increased value of t_1 results in a decreased value of t_2 and vice versa. To have a larger range of distances to choose from a connection with three plates was chosen for this study. Five different combinations that all fulfilled the minimum requirements are presented in Table 5.17.

Table 5.17: Properties of connections with varying distance between plates.

t [mm]	d [mm]	t_1 [mm]	t_2 [mm]	n_p	n_b	n_l	n	l_p [mm]	U_{block} [%]	U_{fast} [%]
10	24	160	250	3	8	5	40	816	40.9	99.5
10	24	180	230	3	8	5	40	816	40.9	97.6
10	24	200	210	3	8	5	40	816	40.9	97.6
10	24	220	190	3	8	5	40	816	40.9	97.6
10	24	240	170	3	8	5	40	816	40.9	97.6

where

t = thickness of the steel plate

d = diameter of the fastener

t_1 = distance from the steel plate to the edge of the beam

t_2 = distance between the steel plates

n_p = number of steel plates

n_b = number of fasteners along the width of the plate

n_l = number of fasteners along the length of the plate

n = total number of fasteners

l_p = length of the plate

U_{block} = utilization ratio with regard to block shear failure

U_{fast} = utilization ratio with regard to shear failure of the fastener

Table 5.18 and Figure 5.7 presents the stiffness and deformation results with varying distances between the slotted-in steel plates in the connection.

Table 5.18: Stiffness and displacement for connections with varying distance between plates.

K_u [kN/m]	n	t_1	t_2	K_{tot} [kN/m]	difference	u [mm]
14630	40	160	250	1590000	1.000	614.2
14630	40	180	230	1598000	1.005	613.0
14630	40	200	210	1603000	1.008	612.2
14630	40	220	190	1606000	1.010	611.8
14630	40	240	170	1607000	1.011	611.6

where

K_u = slip modulus for one fastener in ULS

n = total number of fasteners

t_1 = distance from the steel plate to the edge of the beam

t_2 = distance between the steel plates

K_{tot} = total slip modulus for the whole connection

u = maximum total displacement

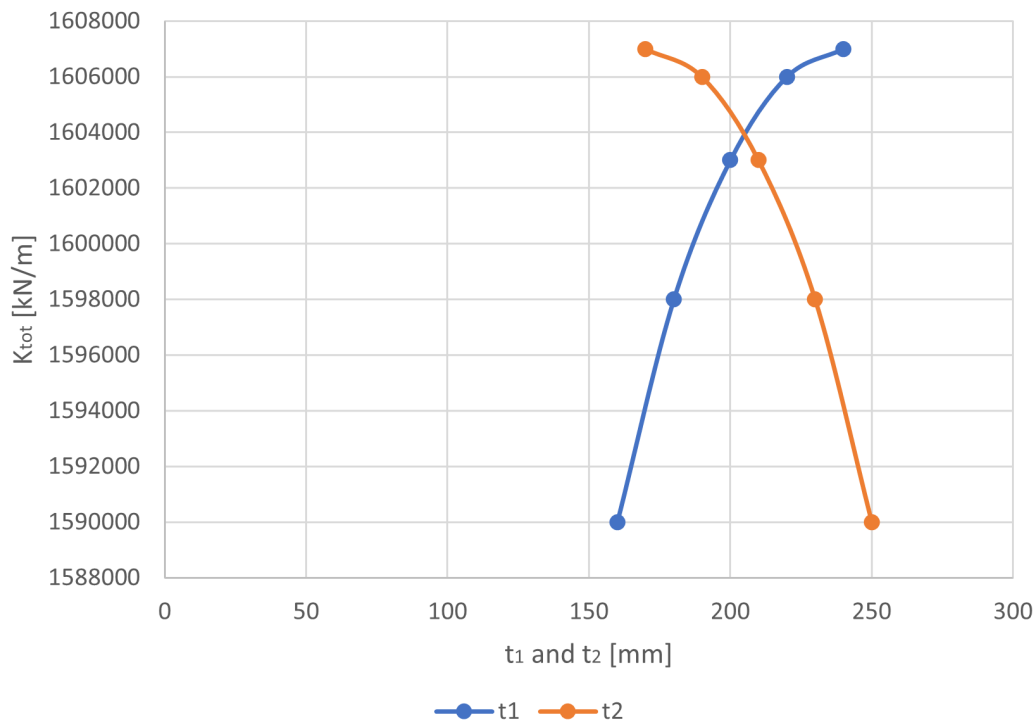

Figure 5.7: Change of stiffness with varying distance between plates.

These changes gave very small differences of the total stiffness with just over 1 % change between the first and the last version in Table 5.18. Even though the differences were very small having the plates closer together appeared to be slightly more beneficial. Although, the placement of the steel plates barely affected the stiffness at all and can therefore be chosen to a number that seems appropriate for the number of plates as long as it fulfills the requirements for the minimum values.

As can be seen in Figure 5.7 the two curves for t_1 and t_2 are symmetrical. As mentioned they are dependent of each other so when t_1 increases t_2 will decrease and vice versa. The inclination of the curves is larger for lower t_1 and higher t_2 . This means that the change of stiffness is larger when the plates are wider apart and closer to the edges. The inclination then decreases as the plates are moved closer together.

5.5.7 Important parameters to reach high stiffness in connections

By studying different properties' effect on the total stiffness some conclusions about improvements of the connections can be made. Some of the studied properties can be adjusted infinitely while some have limitations, the comparison can therefore in some cases be slightly misleading but it gives an indication of the most important parameters.

It was previously stated that there might not be necessary to have a larger stiffness than 3500000 kN/m. The reason for this was that larger stiffnesses did not have as much effect on the deflection compared to smaller stiffnesses. This can be further investigated during the design and improvements of new connections to find a final stiffness that satisfies the requirements.

In the performed analyses it became very apparent that the property that affected the stiffness the most was the number of slotted-in steel plates. An efficient improvement with regard to stiffness can therefore be to increase the amount of steel plates. Two parameters that appeared to have small impact on the global stiffness were the thickness of the slotted-in steel plates and the distance between them. Since the plate thickness had small effect on the stiffness a thinner plate should be aimed for to decrease the steel amount in the connection. The distance between the plates can be chosen to what seems appropriate with other aspects in consideration. For example, choosing a distance that is the most beneficial to achieve the maximum capacity per fastener or to decrease the risk of block shear failure. The dowel dimension and the number of dowels are often strongly connected and both these parameters turned out to have a somewhat large influence on the stiffness. To sum up, the most efficient ways to reach a higher stiffness of a slotted-in steel plate connection is to use a large number of steel plates and a small dimension of the fasteners, and thereby also increasing the amount of fasteners.

5.6 Redesigned connections

When the maximum displacements of the structure for the different connections were studied it was clear that all of the studied connections gave very large displacements which indicates that the connection stiffness eventually is too low. The analysis was made in ULS which means that the SLS displacement requirement most probably will be hard to fulfill. However, some new connections were designed to see the effect of a stiffer connections and they were designed based on the results from previous studies of what affects the stiffness the most. The new connections are called connections F-M and the properties of them are presented in Table 5.19.

The new connection proposals are designed with different aspects taken into account. Some thoughts on how they were chosen are presented below:

- **F:** The stiffness study results showed that smaller dowel dimensions lead to larger stiffness. In the previous designs A-E 12 mm dowels were not included in the study. As 12 mm is considered as a smaller dowel it was used for connection F with the total number of dowels chosen to a larger number than the minimum with regard to the load-bearing capacity, to hopefully reach a decent stiffness.
- **G:** Connection G had many similarities with F but with an increased amount of dowel rows along the length of the plate. This, to see how the stiffness changed with more dowels and if it would be needed with a larger amount to reach the desired stiffness.

- **H:** For connection H the dowel dimension was increased to 16 mm to analyse which dimension was most suitable for the connection. That also lead to a decreased amount of dowels. Otherwise it had similar properties as the two previous ones.
- **I:** As mentioned it was of interest to compare what amount of dowels that was needed and therefore another 16 mm connection with four steel plates was chosen as an alternative. Connection I had four more dowel rows along the length of the plate compared to H.
- **J:** A connection with a larger dowel dimension was developed as connection J with the purpose to see its potential. J had similarities to connection E but with an increased amount of dowels to see the effect on the connection stiffness.
- **K:** The results from the stiffness analysis clearly showed that an increased number of steel plates lead to an increased total stiffness. A connection with 16 mm dowels and six slotted-in steel plates was therefore developed. Due to the large number of steel plates it also had fewer dowels than most of the other connections. Despite this, the dowel amount was not chosen to the smallest possible but picked to hopefully give a larger stiffness. The number of dowels along the width of the plate was also chosen to a smaller number than what is possible to fit to get a more evenly distributed placement of the dowels.
- **L:** Connection L was also a connection with a larger amount of steel plates but with 12 mm dowels, which was smaller than K, to see which combination was most favourable for the connection stiffness.
- **M:** In order to find a sufficient relation between the dowel dimensions and the number of plates connection M was chosen to have 10 mm dowels and eight slotted-in steel plates.

Table 5.19: Properties of connections F-M.

	t [mm]	d [mm]	t_1 [mm]	t_2 [mm]	n_p	n_b	n_l	n	l_p [mm]	U_{block} [%]	U_{fast} [%]
F	10	12	150	170	4	17	8	136	588	41.4	73.0
G	10	12	150	170	4	17	12	204	828	41.4	50.7
H	10	16	150	170	4	12	8	96	784	41.4	63.1
I	10	16	150	170	4	12	12	144	1104	41.4	43.8
J	10	24	150	170	4	8	8	64	1176	41.4	49.2
K	10	16	100	118	6	12	5	60	544	42.4	65.5
L	10	12	48	114	7	14	4	56	348	43.0	99.0
M	10	10	82	86.6	8	16	4	64	310	43.5	99.4

where

t = thickness of the steel plate

d = diameter of the fastener

t_1 = distance from the steel plate to the edge of the beam

t_2 = distance between the steel plates

n_p = number of steel plates

n_b = number of fasteners along the width of the plate

n_l = number of fasteners along the length of the plate

n = total number of fasteners

l_p = length of the plate

U_{block} = utilization ratio with regard to block shear failure

U_{fast} = utilization ratio with regard to shear failure of the fastener

The new connection types were also analysed with regard to stiffness and maximum displacement in the same way as the previous ones. The results in Table 5.20 show that these connection designs have significantly lower utilization ratios for both dowel failure and block shear failure than connections A-E but most of them are clearly stiffer and therefore also leads to smaller horizontal movements. These can be alternative connection designs if the previous ones are not stiff enough.

Table 5.20: Stiffness and displacement for connections F-M.

	K_u [kN/m]	n	K_{tot} [kN/m]	u [mm]
F	7316	136	3352000	464.028
G	7316	204	4122000	433.462
H	9754	96	3019000	481.244
I	9754	144	3243000	469.337
J	14630	64	2756000	497.724
K	9754	60	3200000	471.515
L	7316	56	2764000	496.717
M	6096	64	3101000	476.719

where

K_u = slip modulus for one fastener in ULS

n = total number of fasteners

K_{tot} = total slip modulus for the whole connection

u = maximum total displacement

5.7 Evaluation

Many different versions of the slotted-in steel connection have been designed to find one that is optimal in terms of both load-bearing capacity and stiffness. To make a final decision of which one is most suitable for the 200 m timber tower a final evaluation was performed on the redesigned connections.

The first step of the evaluation was to develop a weighting matrix with different criteria based on what is considered important parameters for the connection. The criteria was chosen based on the previously made study. Every criteria was weighted against the others to finally receive a weighting factor that tells how important the criterion is compared to the others. The connections F-M were given a grade between one and five in every criteria and the connection with the highest weighted grade was chosen as the final connection.

5.7.1 Weighting matrix

The eight different criteria in the weighting matrix are:

1. **Number of dowels**

The amount of dowels in the connection. It is considered beneficial with a connection with fewer dowels than one with several due to that less steel is most often needed when the amount is low. It is also easier producing a connection with a smaller number of dowels since less holes needs to be created in both the steel plate and the timber beam and less dowels needs to be mounted in place during production.

2. **Dowel dimension**

There are many different dowel dimensions available, a connection with smaller dimensions gets higher grades in this criterion based on the previous results that connections with smaller dimensions perform better when it comes to stiffness. This criterion is also closely connected to the previous one since the number of dowels is dependent on the dowel dimension.

3. **Number of plates**

Changing the number of plates in the connection appeared to give a major change of the connection stiffness. It was therefore decided that a high grade would be given to the connections with several steel plates. A disadvantage of this could be that increasing the amount of steel plate could also lead to an increased amount of steel in the connection which might be negative. This is something that should be taken into account when making the final decision of the connection type.

4. **Plate thickness**

The thickness of the plates in the connection also affects the total amount of steel in the connection but it could also be determined that the plate thickness has a very small impact on the total stiffness. It was therefore decided that the steel amount was a more important factor and that connections with thinner steel plates would get higher grades than connections with thicker steel plates.

5. **Distance between plates**

Changing the distance between the steel plates in the connection had overall small effects on the total stiffness but it could still be observed that smaller t_2 lead to larger stiffness. Connections with smaller distances therefore got higher grades in this category.

6. **Length of steel plate**

The length of the steel plate is entirely dependent on the number of fasteners and therefore also the dimension of them. The combination of these two is deciding the plate length but some combinations of amount and dimension are more efficient than others. To decrease the amount of steel in the connection a shorter plate was aimed for.

7. **Utilization ratio**

The utilization ratio criteria refers to the block shear capacity and the shear capacity of the fasteners. Since the utilization of block shear is very similar for all the connections the utilization of the fasteners has mostly been considered for this grading. A larger utilization ratio means that the shear action is closer

to the shear capacity and that the connection is more efficiently used. Larger utilization ratios therefore leads to higher grades.

8. Stiffness

When redesigning the connections a larger stiffness was aimed for and therefore the connections with the highest stiffnesses gets the highest grades.

The intention with the weighting matrix is to determine the importance of the eight criteria relative to the others. The criteria were therefore weighted against each other in the matrix. If the first criterion is considered more important than the second the first receives a score of 3 and the second a score of 1. If two criteria are considered equally important they both get a score of 2. The total score for each criterion is summarized and thereafter divided by the total score to get the weighting factor for each criterion. The results of the weighting are shown in the weighting matrix in Figure 5.8.

	Evaluation criteria	1.	2.	3.	4.	5.	6.	7.	8.	Total score	Weighting factor	Placing
1.	Number of dowels		1	1	3	3	2	3	1	14	0,13	4
2.	Dowel dimensions	3		1	3	3	3	3	1	17	0,15	3
3.	Number of plates	3	3		3	3	3	3	1	19	0,17	2
4.	Plate thickness	1	1	1		3	1	2	1	10	0,09	6
5.	Distance between plates	1	1	1	1		1	1	1	7	0,06	8
6.	Length of steel plate	2	1	1	3	3		3	1	14	0,13	4
7.	Utilization ratio	1	1	1	2	3	1		1	10	0,09	6
8.	Stiffness	3	3	3	3	3	3	3		21	0,19	1
Total										112	1,00	

Figure 5.8: The weighting matrix.

During the weighting many of the decisions were based on the previous results showing what parameters that has the largest effect on the stiffness. As the aim of the new designs was to reach a higher stiffness the stiffness criteria was weighted as the most important with a weighting factor of 0.19. The optimization study showed that the amount of plates had a large effect on the stiffness and it was therefore given high scores in the weighting. Furthermore, the dowel dimension turned out to have larger effect on the stiffness than many of the other criteria and was therefore assigned the third largest weighting factor. The parameters that appeared to be less important for the stiffness, such as the distance between the plates and the plate thickness, ended up with smaller weighting factors. The utilization ratio is important as it shows the load-bearing capacity but because the intention with the new designs was an increased stiffness it was ranked relatively low in the weighting. Both the number of dowels and the length of the plate are quite important factors regarding the steel amount in the connection but since both of them are very dependent on

other parameters, such as the dowel dimension, they got a placing somewhere in the middle.

5.7.2 Grading matrix

As mentioned the connections F-M were given grades between 1-5 in the eight categories where 5 means that the connection has very good properties in that category and 1 means the opposite. To get the final weighted grade for the connections the grade for every criteria was multiplied with the weighting factor from the weighting matrix and then summarized. The grading matrix is shown in Figure 5.9.

During the grading the connections were compared with each other in the eight categories to determine how the grades would be distributed.

	Evaluation criteria	F	G	H	I	J	K	L	M
1.	Number of dowels	2	1	4	2	5	5	5	5
2.	Dowel dimensions	4	4	3	3	1	3	4	5
3.	Number of plates	3	3	3	3	3	4	5	5
4.	Plate thickness	4	4	4	4	4	4	4	4
5.	Distance between plates	3	3	3	3	3	4	5	5
6.	Length of steel plate	4	2	3	1	1	4	5	5
7.	Utilization ratio	4	3	3	2	2	3	5	5
8.	Stiffness	3	5	3	3	2	3	2	3
	Weighted grade	3,33	3,24	3,21	2,63	2,51	3,70	4,20	4,54

Figure 5.9: The grading matrix.

The connection that got the highest weighted grade was connection M. As Figure 5.9 shows it got the highest score in many of the categories and therefore also a high weighted grade. Some of the benefits with M are that it has many slotted-in steel plates which also generates small distances between the plates, it has small dowels which according to Section 5.5.3 gives a higher stiffness and the utilization ratio of the fasteners is very high. Connection M has been optimized in many of the criteria and is therefore very suitable for this purpose.

5.7.3 Amount of steel

Before the final selection of the optimal connection was made an analysis of the amount of steel used in every connection performed. Since the steel amount was included in some of the categories in the grading, the connection with the highest grade should have a relatively small amount of steel and this analysis was done as a verification of that. To make a fair comparison between the different connections it was decided that the amount of steel in 1.5 metres of the beam, see Figure 5.10, would be calculated as a ratio in percent.

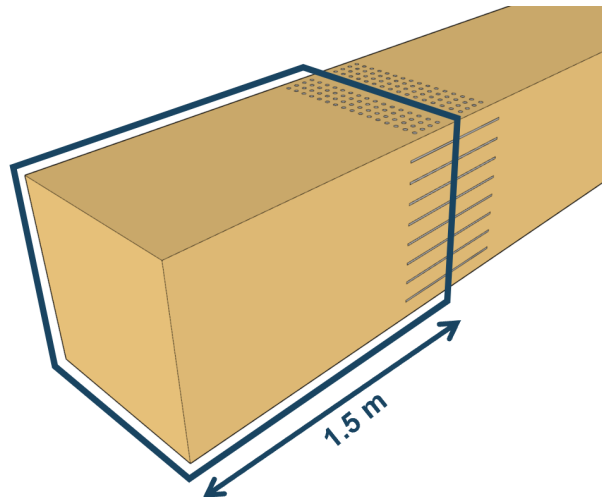

Figure 5.10: The steel amount was compared for 1.5 m of the beam.

In Table 5.21 the results are presented. The steel volume includes the total volume of all the plates and dowels in one half of the connection, i.e. the part of the connection in one of the beams in the joint, also marked within the blue lines in Figure 5.10. The steel ratio shows the amount of steel in 1.5 metres of the beam in percent.

Table 5.21: Amount of steel for connections F-M.

	F	G	H	I	J	K	L	M
Steel volume [m^3]	0.033	0.048	0.043	0.062	0.065	0.038	0.026	0.025
Steel ratio [%]	3.15	4.61	4.14	6.08	6.34	3.63	2.47	2.40

From these results it can be concluded that connection M both got the highest grade in the grading matrix and contains the least amount of steel. As predicted the grading matrix resulted in a connection with lower amount of steel than many of the other connections.

5.7.4 Analysis in SLS

As a last check of the connection an investigation of the maximum displacement in SLS was performed for connection M. The intention with this analysis was to compare the deflection with the limit of $H/500$ set up for SLS deformations. The maximum normal force in SLS of 4873 kN was used for the SLS analysis. The results of the SLS analysis are presented in Table 5.22. The limit of $H/500$ equals 400 mm for a 200 m tall building. Hence, the result of 287 mm deflection fulfills the requirement.

Table 5.22: Stiffness and displacement for connection M in SLS.

K_{ser} [kN/m]	$K_{tot,SLS}$ [kN/m]	u_{SLS} [mm]
7316	4552000	287.3

where

K_{ser} = slip modulus for one fastener in SLS

$K_{tot,SLS}$ = total slip modulus for the whole connection in SLS

u_{SLS} = maximum total horizontal displacement in SLS

5.8 The final connection

Based on the grading matrix connection M was the most suitable connection for the purpose. Apart from that it was the connection of the final suggestions that contained the least steel amount and it also fulfilled the deformation requirements in SLS. Connection M was therefore chosen as the final connection for the bottom floors of the 200 m timber tower. The properties of the final connection are presented in Table 5.23 and Figure 5.11.

Table 5.23: Properties of the final connection.

Thickness of steel plates, t [mm]	10
Diameter of dowels, d [mm]	10
Distance from edge to plate, t_1 [mm]	82
Distance between plates, t_2 [mm]	86.6
Number of plates, n_p	8
Number of dowels along the width, n_b	16
Number of dowels along the length, n_l	4
Total number of dowels, n	64
Length of steel plate, l_p [mm]	310
Utilization ratio block shear, U_{block} [%]	43.5
Utilization ratio fastener shear, U_{fast} [%]	99.4
Slip modulus per dowel in ULS, K_u [kN/m]	6096
Slip modulus per dowel in SLS, K_{ser} [kN/m]	7316
Connection stiffness in ULS, K_{tot} [kN/m]	3101000
Connection stiffness in SLS, $K_{tot,SLS}$ [kN/m]	4552000
Maximum global displacement in ULS, u [mm]	476.7
Maximum global displacement in SLS, u_{SLS} [mm]	287.3

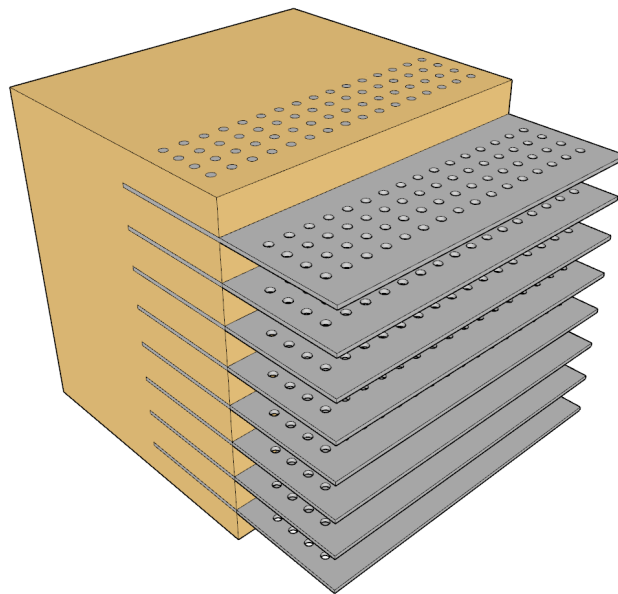

Figure 5.11: Design of the final connection.

6

Discussion

To sum up this study the results, simplifications and unsolved problem are analysed to draw some final conclusions. The connections and the stiffness of them are further discussed to evaluate the results of the thesis.

6.1 Connection design

In the early stage of this study, four different types of connections were investigated, external steel plates, external timber plates, glued-in rods and slotted-in steel plates. A conclusion of these calculations is that connections with external plates are not suitable for joints in the 200 m timber tower since two plates are not sufficient for resisting such large forces. Connections with slotted-in steel plates on the other hand are suitable. These connections can be varied and adjusted in many ways to suit the beam and to reach the required capacity. In addition, it is possible to connect more than two beams which makes this connection type applicable for more complicated connections than described in this study, for further reading see Section 6.4. Glued-in rods connections can be an alternative for resisting large forces although these were not studied thoroughly in this study. Even though Eurocode is not including any design rules regarding glued-in rods yet, there are significant research and testing of these connections. It is therefore reasonable to expect that these types of joints will be more common in the future. One disadvantage with all glued connections is the need for a controlled environment which limits the production to factories only (Swedish Wood, 2016a).

For almost all the studied connections throughout this thesis the shear failure of the fasteners turned out to be more crucial than the block shear failure. The block shear failure utilization ratio never exceeded 45 % and was therefore not critical for any of the suggested connections. The utilization ratio of shear failure of the fasteners varies a lot depending on the connection. To fully take advantage of the used materials a high utilization ratio is to aim for but in the search for a stiff connection the utilization ratio was sometimes downgraded to other criteria. The final connection M, which is described in 5.8, was accomplished to reach both a high stiffness and a high utilization ratio. This is a validation that the connection has been optimized in terms of both load-bearing capacity and stiffness.

The maximum force appears in the bottom of the building and it is thereafter decreased with the height of the building. A quite noticeable decrease can be observed with a maximum force at floor 1 of 5129 kN and a force at floor 53 of 364 kN, not

even a tenth of the maximum force at the bottom floor. It was therefore assumed that due to the large axial forces the connection design most probably will be much more critical in the bottom of the building than higher up. This is why the focus of the design of the connections was decided to be on the first floor.

An aspect that has not been the main focus during this study, but definitely is an important aspect when designing connections, is the production and mounting of the connections. A large amount of dowels means that many holes need to be predrilled, both in the steel plates and in the timber. Assembly of a connection with many dowels will also be more time consuming compared to one with fewer dowels. It is therefore not realistic to have a connection with several hundred fasteners, even though it probably would be a very stiff connection. Out of the eight redesigned connections, three of them had more than 100 dowels, which is considered as a relatively large amount. The number of fasteners was considered during the weighting, as few dowels gave a higher grade in the grading matrix. This was partly due to the steel amount in the connection but also with the production of the connection in mind.

The purpose of the first connection designs A-E was to examine five connections with different properties to be able to make a first overview of which properties that were the most beneficial for the stiffness, see Section 5.2.3. Properties like dowel dimension and number of plates were chosen to get a variation of connections and they were all designed to reach a high utilization ratio. Already from the first five connections it was clear that connection A, with many steel plates and small dowels, had a significantly larger stiffness than the others, a result that later was confirmed in the stiffness analysis. Connection B had lower stiffness than A but still higher than the other ones, this was probably also because of the larger number of plates. Hence, a hint of the results was showed already in the first analysis.

6.2 Stiffness analysis

An important aspect to consider when reading this study is that the values for the calculated stiffnesses should not be taken as exact values for the connections. These values were mostly used in order to analyse the affecting parameters and to compare different design of connections. Even though a simple verification was conducted, a more thorough verification has to be completed, preferable including practical tests in a laboratory in order to use the exact numbers of the stiffness for other purposes.

The analysis of how the maximum displacement of the building was affected by the stiffness can be seen in Section 5.5.1. The conclusion was drawn that it would probably not be necessary to aim for a stiffness above 3500000 kN/m as the displacement thereafter was not changed in the same extent. The final connection landed on a stiffness of 3101000 kN/m and that turned out to be sufficient enough. Consequently, the assumption turned out to be correct and a higher stiffness was not needed for this building. It can be determined that the stiffness versus displacement analysis gave a reasonable result that was applicable on the further analyses.

When investigating how the stiffness was affected by the dowel dimension it was concluded that a smaller dowel dimension leads to a higher stiffness. However, this might be misleading as a smaller dowel dimension also means a larger amount of dowels. It can therefore be difficult to determine if it is the dimension or the amount of dowels that has the largest effect on the stiffness. In the study it was chosen that the number of dowels would be adjusted based on the dimension, minimum spacing and the utilization ratio. It could be interesting to perform a study of how the stiffness would be affected when the number of dowels was kept constant and only varying the dowel dimension. Such a connection could be difficult to design though, because many factors are dependent on the dowel dimension and it would be complicated to fit the same amount of dowels for a dimension of 24 mm as for 10 mm. The minimum distances between the dowels are affected where larger dowels requires a larger spacing, which makes it difficult to find an amount that is appropriate for many different dimensions. Hence, analysing how the dimension of the fastener affects the stiffness is complex and it can be complicated to determine if it is the dimension or the amount that has the largest influence, but it can be established that the combination of a smaller dimension and a higher amount is beneficial for the stiffness.

6.3 Final connection

The redesigned connection suggestions F-M were formed based on the previous investigations. However, only eight out of infinitely many connection designs were studied. It may therefore exist connections and other combinations of properties that are even more optimized. The final connection M is although considered optimized enough as it received high scores in a majority of the criteria and also fulfills the other design requirements.

The final connection was chosen with the help of a weighting matrix where different criteria were set up and compared against each other to decide the order of importance of the criteria. The weighting was partly based on the results from previous investigations but also on the opinions of the authors. The same applies for the grading matrix where both analyses and personal opinions decided which properties that would get high grades. Therefore, the outcomes does not show a right or wrong answer, just the results of what is considered important aspects and valuable properties in the design of connection.

The redesign of the connections was performed based on the results from the optimization of stiffness study. Different parameters were changed with the purpose to reach an increased stiffness. The achieved stiffnesses in Table 5.20 varies between 2700000-4100000 kN/m, a quite large range. If the evaluation would be based only on the stiffness, connection G would have been chosen as the final proposal. Although, since the choice was made with the help of a weighting matrix, where several aspects are considered, connection M was the final proposal. Among the eight redesigns, connection M had an average stiffness and a grade 3 for the stiffness in the grading matrix. Despite this, it got the highest weighted grade because of

the other advantageous properties of M. Even though the stiffness of M was not the highest it turned out to be sufficient enough and that in combination with the other benefits made it very suitable as the final connection.

Regarding the investigation of the amount of steel in the redesigned connections it was made as a comparison to make sure that the chosen alternative did not have a particularly large amount of steel, in comparison to the other alternatives. Connection M turned out to contain the least amount of steel of the evaluated connections. It was early in the study expressed that a small amount of steel would be aimed for due to costs and environmental impact. If the final connection had not fulfilled that criterion, the evaluation should probably have been reviewed one more time to attain a connection with less steel.

When fixed joints were applied for the entire building it resulted in a maximum deformation of 170 mm. The joint stiffness was then changed from fixed to the stiffness determined for the final connection M. This change resulted in an increment of the deformation from 170 mm to 287 mm. This means that the change in stiffness increases the deformation with 117 mm which corresponds to +68.8 %.

The requirement $H/500$ is often used for deformation with SLS load combination. If the deformation is determined with fixed connections, this requirement should be increased in order to account for the additional deformation due to lower connection stiffness.

The total deformation for the 200 m timber tower is restricted to 400 mm, see Equation 6.1.

$$\frac{H}{500} = \frac{200}{500} = 0.40 \text{ m} = 400 \text{ mm} \quad (6.1)$$

The deformation when using fixed connection should therefore be controlled according to Equation 6.2.

$$U = 400/1.688 = 236.9 \text{ mm} \quad (6.2)$$

This means that if the deformation determined with fixed connections is lower than 236.9 mm, this corresponds to a deformation lower than 400 mm with the stiffness for connection M and meets thus the deformation requirements of $H/500$.

A new deformation requirement could be concluded for deformations calculated with fixed joints, this would then take the extra deformation due to lower stiffness into account. The requirement can be calculated as Equation 6.3

$$\frac{H}{500 \cdot 1.688} = \frac{H}{844} \quad (6.3)$$

A suitable requirement for the model with fixed connections could therefore be $\frac{H}{850}$.

A limitation in this study is that the connection designed for the largest beam has been used for all joints in the building, this may give inaccurate results when analysing the total displacement in the Grasshopper model. Even though the dimension of the beams decreases with the height of the building, the same connection stiffness was applied for all the connections in the building. The connection designed for the largest beam is probably stiffer than the connections that should be used for the smaller beams. This could imply that the applied stiffness was larger than it would have and therefore results in a lower deformation.

The FE-study in FEM-design could be elaborated and one improvement that could be done is to include the holes for the dowels in both the timber and the steel plate. In the model used in this study, both the steel plate and timber plate were solid, i.e. no holes, and this probably makes the connection stiffer than it actually is. Partly because drilled holes mean less material but also because the stress distribution could be affected. It would be interesting to see how this change would affect the deformation and the stiffness. One problem with this improvement could be where to place the point connections. In the models used for this study, a point connection is placed in the center of the calculated position of every dowel and is assembled between the two faces of materials. If there was a hole for each dowel this would mean that there would be no surfaces to establish the point connection between.

6.4 Improvements and future studies

In regard to load-bearing capacity, stiffness and displacement of connections loaded with axial loads the requirements are fulfilled. However, more aspects concerning the connections, such as dynamic loads and fatigue, needs to be studied for the final design. Further, loads in directions other than parallel to the beam, i.e. axial load, has to be considered. Not only can the connections be further investigated, but also the tall timber structure in general. Fire resistance, foundation and robustness are examples of studies that needs to be performed to reach a final design.

Another suggestion for further studies could be design of more complicated connections. This study exclusively includes analyses of connections between two beams in the same direction. In a building like the 200 m timber tower there are most certainly joints with more than two beams connecting. Furthermore, the connecting beams could have varying angles. Designing these kinds of connections could be a suggestion for further studies. The slotted-in connection could be a proposal for these connections as well, although the shape of the steel plate must be designed to cover all the connecting beams, for an illustration of an example see Figure 6.1.

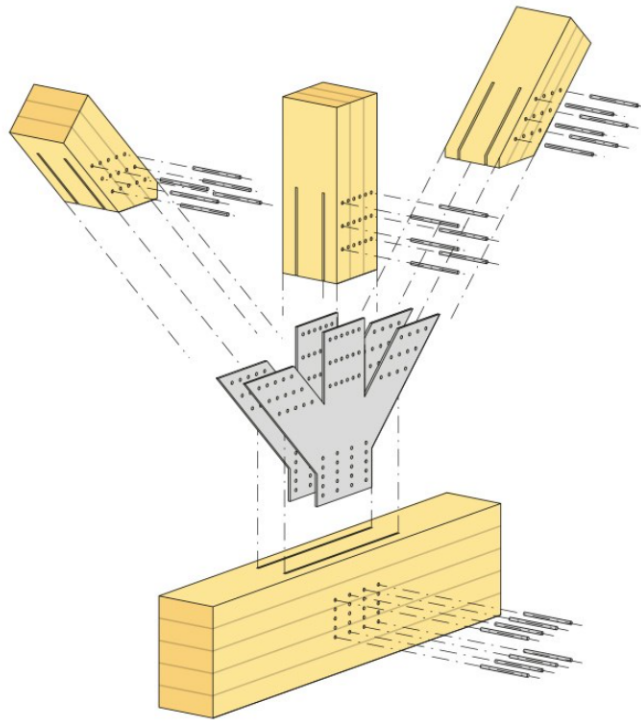

Figure 6.1: Example of a slotted-in steel joint with several connecting beams (Croce, 2016).

7

Conclusion

The work of investigating the possibilities of building a 200 m tall timber tower has now been made in three parts, first studying the design and geometry of the structure and now analysing the connections between load-bearing elements. So far, it has been concluded that it would be possible to build the tower and to find suitable connections that are capable of carrying the loads, although further investigation has to be conducted for the final design.

A conclusion of this study is that the slotted-in steel plate connections are appropriate alternatives for the joints in a 200 m tall timber building. They can be varied and adjusted in many different ways to be made suitable for the specific case. It is possible to reach a high stiffness with this type of connections which is of large significance for tall structures since the stiffness has considerable influence on the deformation of the building.

By studying different parameters' effect on the stiffness it can be concluded that the number of steel plates in the slotted-in steel plate connection has the largest impact on the stiffness. Stiffer connections are achieved when a larger amount of steel plates are used. The amount and the dimension of the dowels are also important factors and the combination of small dowels and a large amount appeared to be the most beneficial for the connection stiffness.

Based on the performed investigations a proposal for the final connection have been made. With a combination of many steel plates, small dowels dimension, large utilization ratio and a small amount of steel, the final connection had many of the desired properties. According to the investigated parameters in this study the connection fulfills the requirements but to make a final determination about the possibility to build the 200 m timber tower more aspects need to be studied.

Bibliography

- Abrahamsen, R. (2017). *Mjøstårnet - Construction of an 81 m tall timber building*. Conference proceedings of Internationales Holzbau-Forum IHF 2017.
- Abrahamsen, R., & Malo, K. A. (2014). *Structural design and assembly of "Treet" - a 14-storey timber residential building in Norway*. Conference proceedings of World Conference on Timber Engineering 2014.
- Al-Emrani, M., Engström, B., Johansson, M., & Johansson, P. (2013). *Bärande konstruktioner del 1*. Chalmers tekniska högskola.
- Arnold Laver. (2022). *Hardwood vs Softwood: What's the Difference?* <https://www.laver.co.uk/blog/hardwood-vs-softwood-whats-the-difference/>
- Blaß, H. J., & Sandhaas, C. (2017). *Timber Engineering Principles for design*. KIT Scientific Publishing.
- Canadian Wood Council. (2016). *Factsheet: Brock Commons Storyboards: Design, Compliance and Performance*. https://www.naturallywood.com/wp-content/uploads/brock-commons-storyboards_factsheet_naturallywood.pdf
- Cepelka, M. (2017). *Splicing of Large Glued Laminated Timber Elements by Use of Long Threaded Rods* (Doctoral dissertation). Norwegian University of Science and Technology.
- Crocetti, R. (2016). Förband som klarar stora laster. *Trä!*, (4), 28–29.
- Dangel, U. (2021). *Timber in the city: Integrating low-carbon construction practices into the architectural curriculum*. World Conference on Timber Engineering (WCTE).
- Huber, J. A. J., Ekevad, M., Girhammar, U. A., & Berg, S. (2018). *Structural Robustness and Timber Buildings - a review*. Wood Material Science & Engineering. <https://doi.org/10.1080/17480272.2018.1446052>
- ITB Berlin. (2021). *Skelleftea, sweden's new "must visit" destination*. <https://news.itb.com/regional-spotlight/europe/skelleftea-destination/>
- Johansson, M., Linderholt, A., Bolmsvik, Å., Jarnerö, K., Olsson, J., & Reynolds, T. (2015). *Building higher with light-weight timber structures – the effect of wind induced vibrations*. Conference proceedings of Internoise 2015.
- Landel, P., Johansson, M., & Linderholt, A. (2021). *Comparative study of wind-induced accelerations in tall timber buildings according to four methods*. Conference proceedings of World Conference on Timber Engineering 2021.
- Moelven. (2022). *Mjøstårnet*. <https://www.moelven.com/mjostarnet/>
- Ramboll. (2022). *Varför bygga i trä?* <https://c.ramboll.com/sv-se/varfor-bygga-i-tra>

- Salvadori, V. (2021). *Multi-storey timber-based buildings: An international survey of case-studies with five or more storeys over the last twenty years*. Technische Universität Wien.
- Swedish Institute of Standards (SIS). (2002). *SS-EN 1990: Grundläggande dimensionering för bärverk*.
- Swedish Institute of Standards (SIS). (2003). *SS-EN 1991: Laster på bärverk*.
- Swedish Wood. (2016a). *Design of timber structures Volume 1*. Swedish Forest Industries Federation.
- Swedish Wood. (2016b). *Design of timber structures Volume 2*. Swedish Forest Industries Federation.
- Swedish Wood. (2016c). *Limträhandboken Del 1*. Swedish Forest Industries Federation.
- Swedish Wood. (2016d). *Limträhandboken Del 3*. Swedish Forest Industries Federation.
- Swedish Wood. (n.d.). *Trä är ett hållbart byggmaterial*. <https://www.svenskttra.se/hallbarhet/tra-och-hallbarhet/tra-ar-ett-hallbart-byggmaterial>
- Taranath, B. S. (2012). *Structural Analysis and Design of Tall Buildings*. Taylor Francis Group.
- Voulpiotis, K. (2022). *Robustness of Tall Timber Buildings*. ETH Zürich.
- Xi, C., Ren, C., Wang, J., Feng, Z., & Cao, S.-J. (2021). *Impacts of urban-scale building height diversity on urban climates: A case study of Nanjing, China*. Energy and Buildings. <https://doi.org/10.1016/j.enbuild.2021.111350>
- Zubizarreta, M., Cuadrado, J., Orbe, A., & García, H. (2019). *Modeling the environmental sustainability of timber structures: A case study*. Elsevier Inc. <https://doi.org/10.1016/j.eiar.2019.106286>

A

Appendix

A.1 Hand calculations for a connection with slotted-in steel plates

Slotted-in steel plate

Controls are marked with blue

Utilisation ratios are marked with green

Variables marked with yellow depends on the connection and are changed depending on the design

$$F := 5129 \text{ kN}$$

maximum normal force from Grasshopper

Steel geometry

Steel plate

$$t := 10 \text{ mm}$$

$$b := 850 \text{ mm}$$

$$h := 1300 \text{ mm}$$

Bolts

$$d := 10 \text{ mm}$$

$$d_{ul} := \frac{d}{mm} = 10$$

Control := $\begin{cases} \text{if } t > 0.3 \cdot d \\ \quad \text{"ok"} \\ \text{else} \\ \quad \text{"increase thickness of steel or reduce diameter of fastener"} \end{cases} = \text{"ok"}$

Material properties

Steel

$$f_{yk} := 460 \text{ MPa}$$

$$\gamma_M := 1.0$$

$$f_{yd} := \frac{f_{yk}}{\gamma_M} = 460 \text{ MPa}$$

Glulam GL30h

$$\rho_k := 490 \frac{\text{kg}}{\text{m}^3}$$

$$\rho_{k,ul} := 490$$

$$f_{c,90k} := 2.5 \text{ MPa}$$

$$\rho_{mean,1} := 480 \frac{\text{kg}}{\text{m}^3}$$

$$\rho_{mean,2} := 480 \frac{\text{kg}}{\text{m}^3}$$

Fastener strength

$$f_u := 800 \text{ MPa}$$

Fastener strength class 8.8

Embedment strength

$$M_{y.Rk} := \frac{f_u}{600} \cdot 180 \cdot d^{2.6} \cdot \text{mm}^{0.4} = 95.546 \text{ N} \cdot \text{m}$$

$$f_{h.k} := 0.082 \cdot (1 - 0.01 d_{ul}) \cdot \rho_{k.ul} = 36.162 \quad f_{h.k} := f_{h.k} \cdot \text{MPa} = 36.162 \text{ MPa}$$

Timber geometry

Glulam GL30h

$$b_t := 850 \text{ mm}$$

Geometry hyperboloid

Cross-section of beams

250 x 250 mm

Cross-section of trusses

Floor 1-7: 850 x 850 mm

$$t_1 := \sqrt{2} \cdot \sqrt{\frac{M_{y.Rk}}{f_{h.k} \cdot d}} + 0.1 \text{ mm} = 23.088 \text{ mm}$$

Minimum distance to edge

$$t_1 := 82 \text{ mm}$$

Chosen distance to edge

$$n_p := 8$$

Number of plates

$$t_2 := \frac{b_t - 2 \cdot t_1 - t \cdot n_p}{n_p - 1} = 86.571 \text{ mm}$$

Distance between plates

t_1 and t_2 controlled to fulfill the minimum requirements

$$\text{Control} := \begin{cases} \text{if } t_1 > \sqrt{2} \cdot \sqrt{\frac{M_{y.Rk}}{f_{h.k} \cdot d}} \\ \quad \parallel \text{ "ok" } \\ \text{else} \\ \quad \parallel \text{ "minimum value for } t_1 \text{ not fulfilled, reduce number of plates" } \end{cases} = \text{ "ok" }$$

$$\text{Control} := \begin{cases} \text{if } t_2 > 1.15 \cdot 4 \cdot \sqrt{\frac{M_{y.Rk}}{f_{h.k} \cdot d}} \\ \quad \parallel \text{ "ok" } \\ \text{else} \\ \quad \parallel \text{ "minimum value for } t_2 \text{ not fulfilled, reduce number of plates" } \end{cases} = \text{ "ok" }$$

Withdrawal capacity

$$D_{washer} := \min(12 \cdot t, 4 \cdot d) = 0.04 \text{ m}$$

$$A_{washer} := \pi \cdot \frac{(D_{washer}^2 - d^2)}{4} = (1.178 \cdot 10^3) \text{ mm}^2$$

$$F_{ax.washer} := 3 \cdot A_{washer} \cdot f_{c.90k} = 8.836 \text{ kN} \quad \text{for bolts}$$

Shear capacity, characteristic value

$$F_{v.Rk.lateral} := \begin{cases} \text{if } n_p = 1 \\ \quad \parallel 0 \text{ kN} \\ \text{else} \\ \quad \text{if } \sqrt{2} \cdot \sqrt{\frac{M_{y.Rk}}{f_{h.k} \cdot d}} < t_1 \leq 1.15 \cdot 4 \cdot \sqrt{\frac{M_{y.Rk}}{f_{h.k} \cdot d}} \\ \quad \parallel 2 \cdot f_{h.k} \cdot d \cdot t_1 \cdot \left(\sqrt{2 + \frac{4 \cdot M_{y.Rk}}{f_{h.k} \cdot d \cdot t_1^2}} - 1 \right) \\ \quad \text{if } t_1 \geq 1.15 \cdot 4 \cdot \sqrt{\frac{M_{y.Rk}}{f_{h.k} \cdot d}} \\ \quad \parallel 2 \cdot 1.15 \cdot \sqrt{2} \cdot \sqrt{2 M_{y.Rk} \cdot f_{h.k} \cdot d} \end{cases} = 27.039 \text{ kN}$$

$$F_{v.Rk.centre} := \begin{cases} \text{if } n_p = 1 \\ \quad \parallel 0 \\ \text{if } n_p = 2 \\ \quad \parallel 2 \cdot 1.15 \cdot \sqrt{2} \cdot \sqrt{2 M_{y.Rk} \cdot f_{h.k} \cdot d} \\ \text{if } n_p = 3 \\ \quad \parallel 2 \cdot 2 \cdot 1.15 \cdot \sqrt{2} \cdot \sqrt{2 M_{y.Rk} \cdot f_{h.k} \cdot d} \\ \text{if } n_p = 4 \\ \quad \parallel 3 \cdot 2 \cdot 1.15 \cdot \sqrt{2} \cdot \sqrt{2 M_{y.Rk} \cdot f_{h.k} \cdot d} \\ \text{if } n_p = 5 \\ \quad \parallel 4 \cdot 2 \cdot 1.15 \cdot \sqrt{2} \cdot \sqrt{2 M_{y.Rk} \cdot f_{h.k} \cdot d} \\ \text{if } n_p = 7 \\ \quad \parallel 6 \cdot 2 \cdot 1.15 \cdot \sqrt{2} \cdot \sqrt{2 M_{y.Rk} \cdot f_{h.k} \cdot d} \\ \text{if } n_p = 8 \\ \quad \parallel 7 \cdot 2 \cdot 1.15 \cdot \sqrt{2} \cdot \sqrt{2 M_{y.Rk} \cdot f_{h.k} \cdot d} \\ \text{if } n_p = 10 \end{cases} = (1.893 \cdot 10^5) \text{ N}$$

$$F_{v.Rk} := \begin{cases} \left\| \left\| 9 \cdot 2 \cdot 1.15 \cdot \sqrt{2} \cdot \sqrt{2} M_{y.Rk} \cdot f_{h.k} \cdot d \right\| \right\| & \text{if } n_p = 1 \\ \left\| \left\| 2 \cdot 1.15 \cdot \sqrt{2} \cdot \sqrt{2} M_{y.Rk} \cdot f_{h.k} \cdot d \right\| \right\| & \\ F_{v.Rk.lateral} + F_{v.Rk.centre} & \text{else} \end{cases} = 216.312 \text{ kN}$$

Shear capacity, design value

$$\gamma_M := 1.3$$

Timber connections

$$k_{mod} := 0.65$$

Load duration class M,
service class 3

$$F_{Rd} := \frac{k_{mod} \cdot F_{v.Rk}}{\gamma_M} = 108.156 \text{ kN}$$

Connection layout

$$fastener := \text{"bolts"}$$

Choose either "bolts" or
"dowels"

$$\alpha := 0 \text{ deg}$$

Angle of fastener

$$end := \text{"loaded"}$$

"loaded" or "unloaded"

$$edge := \text{"loaded"}$$

"loaded" or "unloaded"

$$a_1 := \begin{cases} \left\| \left\| \begin{array}{l} \text{if } fastener = \text{"bolts"} \\ (4 + |\cos(\alpha)|) \cdot d \end{array} \right\| \right\| = 0.05 \text{ m} \\ \left\| \left\| \begin{array}{l} \text{if } fastener = \text{"dowels"} \\ (3 + 2 |\cos(\alpha)|) \cdot d \end{array} \right\| \right\| \end{cases}$$

Minimum spacing parallel
to grain

$$a_1 := 0.15 \text{ m}$$

Chosen spacing parallel
to grain, if not minimum
value is used

$$a_2 := \begin{cases} \left\| \left\| \begin{array}{l} \text{if } fastener = \text{"bolts"} \\ 4 \cdot d \end{array} \right\| \right\| = 0.04 \text{ m} \\ \left\| \left\| \begin{array}{l} \text{if } fastener = \text{"dowels"} \\ 3 \cdot d \end{array} \right\| \right\| \end{cases}$$

Minimum spacing
perpendicular to grain

$$a_2 := 0.05 \text{ m}$$

Chosen spacing
perpendicular to grain, if
not minimum value is used

$$a_3 := \begin{cases} \text{if } fastener = \text{"bolts"} \\ \quad \text{if } end = \text{"loaded"} \\ \quad \quad \max(7 \cdot d, 80 \text{ mm}) \\ \quad \text{if } end = \text{"unloaded"} \\ \quad \quad \text{if } 90 \text{ deg} \leq \alpha < 150 \text{ deg} \\ \quad \quad \quad (1 + 6 \sin(\alpha)) \cdot d \\ \quad \quad \text{if } 150 \text{ deg} \leq \alpha < 210 \text{ deg} \\ \quad \quad \quad 4 \cdot d \\ \quad \quad \text{if } 210 \text{ deg} \leq \alpha \leq 270 \text{ deg} \\ \quad \quad \quad (1 + 6 |\sin(\alpha)|) \cdot d \\ \text{if } fastener = \text{"dowels"} \\ \quad \text{if } end = \text{"loaded"} \\ \quad \quad \max(7 \cdot d, 80 \text{ mm}) \\ \quad \text{if } end = \text{"unloaded"} \\ \quad \quad \text{if } 90 \text{ deg} \leq \alpha < 150 \text{ deg} \\ \quad \quad \quad \max(7 \cdot d, 80 \text{ mm}) |\sin(\alpha)| \\ \quad \quad \text{if } 150 \text{ deg} \leq \alpha < 210 \text{ deg} \\ \quad \quad \quad \max(3.5 \cdot d, 40 \text{ mm}) \\ \quad \quad \text{if } 210 \text{ deg} \leq \alpha \leq 270 \text{ deg} \\ \quad \quad \quad \max(7 \cdot d, 80 \text{ mm}) |\sin(\alpha)| \\ \quad \quad \text{if } 0 \text{ deg} \leq \alpha < 90 \text{ deg} \\ \quad \quad \quad \text{"invalid } \alpha \text{"} \\ \quad \quad \text{if } 270 \text{ deg} < \alpha \leq 360 \text{ deg} \\ \quad \quad \quad \text{"invalid } \alpha \text{"} \end{cases} = 0.08 \text{ m}$$

Minimum spacing to end

-90 deg < alpha < 90 deg means loaded end

$$a_3 := 0.1 \text{ m}$$

Chosen spacing to end, if not minimum value is used

$$a_{4.min} := \begin{cases} \text{if } edge = \text{"loaded"} \\ \quad \max((2 + 2 \cdot \sin(\alpha)) \cdot d, 3 \cdot d) \\ \text{if } edge = \text{"unloaded"} \\ \quad 3 \cdot d \end{cases} = 0.03 \text{ m}$$

Minimum spacing to edge

$$n_b := \frac{b - 2 \cdot a_{4.min}}{a_2} + 1 = 16.8$$

Maximum number of fastener along the width to full minimum spacing

$$n_{b,max} := \text{trunc}(n_b) = 16$$

Maximum allowable number of fastener along the width

$$n_b := 16$$

Chosen number fastener along the width

$$a_4 := \frac{b - (n_b - 1) \cdot a_2}{2} = 0.05 \text{ m}$$

Chosen spacing to edge, if not minimum value is used

$$\text{Control} := \begin{cases} \text{if } a_4 > a_{4,min} \\ \quad \text{"ok"} \\ \text{else} \\ \quad \text{"not ok"} \end{cases} = \text{"ok"}$$

Rope effect

$$n_h := 0$$

Starting value for calculation of number of fasteners in one row

$$n_h^{0.9} \cdot \sqrt[4]{\frac{7 \cdot d}{13 \cdot d}} = \frac{F_{tension}}{F_{Rd} \cdot n_b}$$

$$n_h := \left(\frac{F}{F_{Rd} \cdot n_b \cdot \sqrt[4]{\frac{7 \cdot d}{13 \cdot d}}} \right)^{\frac{1}{0.9}} = 3.972$$

$$n_h := \text{trunc}(n_h) + 1 = 4$$

$$n_{tot} := n_h \cdot n_b = 64$$

Total number of dowels

$$l_p := a_3 + (n_h - 1) \cdot a_1 + a_3 = 0.31 \text{ m}$$

Length of the steel plate

$$\text{Control} := \begin{cases} \text{if } l_p < h \\ \quad \text{"ok"} \\ \text{else} \\ \quad \text{"not ok"} \end{cases} = \text{"ok"}$$

Block shear failure

$$f_{t.0.k} := 24 \text{ MPa}$$

tensile strength parallel to the grain

$$f_{v.k} := 3.5 \text{ MPa}$$

shear strength

$$A_{net.v} := n_h \cdot a_1 \cdot ((n_p - 1) \cdot t_2 + 2 \cdot t_1) = 0.154 \text{ m}^2$$

Net area of the end

$$A_{net.t} := ((n_b - 1) \cdot a_2 + 2 \cdot a_4) \cdot ((n_p - 1) \cdot t_2 + 2 \cdot t_1) = 0.655 \text{ m}^2$$

Net area of the sides

$$1.5 \cdot A_{net.t} \cdot f_{t.0.k} = (2.356 \cdot 10^4) \text{ kN}$$

$$0.7 \cdot A_{net.v} \cdot f_{v.k} = 377.3 \text{ kN}$$

$$F_{bs.Rk} := \max(1.5 \cdot A_{net.t} \cdot f_{t.0.k}, 0.7 \cdot A_{net.v} \cdot f_{v.k}) = (2.356 \cdot 10^4) \text{ kN}$$

$$F_{bs.Rd} := F_{bs.Rk} \cdot \frac{k_{mod}}{\gamma_M} = (1.178 \cdot 10^4) \text{ kN}$$

Block shear resistance, design value

$$\text{Control} := \left\| \begin{array}{l} \text{if } F_{bs.Rd} > F \\ \quad \left\| \begin{array}{l} \text{"ok"} \\ \text{if } F_{bs.Rd} < F \\ \quad \left\| \begin{array}{l} \text{"not ok"} \end{array} \right. \end{array} \right. \end{array} \right\| = \text{"ok"}$$

$$n_h \cdot n_b \cdot F_{Rd} = (6.922 \cdot 10^3) \text{ kN}$$

$$F = (5.129 \cdot 10^3) \text{ kN}$$

$$\text{Control} := \left\| \begin{array}{l} \text{if } n_h^{0.9} \cdot \sqrt[4]{\frac{7 \cdot d}{13 \cdot d}} \cdot n_b \cdot F_{Rd} > F \\ \quad \left\| \begin{array}{l} \text{"ok"} \\ \text{if } n_h^{0.9} \cdot \sqrt[4]{\frac{7 \cdot d}{13 \cdot d}} \cdot n_b \cdot F_{Rd} < F \\ \quad \left\| \begin{array}{l} \text{"not ok"} \end{array} \right. \end{array} \right. \end{array} \right\| = \text{"ok"}$$

Utilization ratio

$$\frac{F}{F_{bs.Rd}} = 0.435$$

$$\frac{F}{n_h^{0.9} \cdot \sqrt[4]{\frac{7 \cdot d}{13 \cdot d} \cdot n_b \cdot F_{Rd}}} = 0.994$$

Slip modulus

$$\rho_m := \sqrt{\rho_{mean.1} \cdot \rho_{mean.2}} = 480 \frac{kg}{m^3}$$

Mean density

$$K_{ser} := \frac{2 \cdot \left(\frac{\rho_m}{\frac{kg}{m^3}} \right)^{1.5} \cdot \frac{d}{mm}}{23} = 9.145 \cdot 10^3$$

Slip modulus, SLS

$$K_{ser} := K_{ser} \frac{N}{mm} = (9.145 \cdot 10^3) \frac{kN}{m}$$

$$K_u := \frac{2}{3} K_{ser} = (6.096 \cdot 10^3) \frac{kN}{m}$$

Slip modulus ULS

Stiffness

For timber thickness t1

For timber thickness t2

$$t_1 = 82 \text{ mm}$$

$$t_2 = 86.571 \text{ mm}$$

timber thickness

$$x_1 := 1.6576 \text{ mm}$$

$$x_2 := 1.6528 \text{ mm}$$

displacement of the connection, from analysis in FEM-design

$$F_p := \frac{F}{n_p} = 641.125 \text{ kN}$$

$$F_p := \frac{F}{n_p} = 641.125 \text{ kN}$$

Force in one plate

$$k_1 := \frac{F_p}{x_1} = (3.868 \cdot 10^5) \frac{\text{kN}}{\text{m}}$$

$$k_2 := \frac{F_p}{x_2} = (3.879 \cdot 10^5) \frac{\text{kN}}{\text{m}}$$

Stiffness for one steel plate + one timber plate

Total stiffness

$$k_{tot} := \begin{cases} \text{if } n_p = 1 \\ \quad \parallel \\ \quad \parallel k_1 \\ \quad \parallel \\ \text{else} \\ \quad \parallel \\ \quad \parallel k_1 \cdot 2 + (n_p - 2) \cdot k_2 \\ \quad \parallel \end{cases} = (3.101 \cdot 10^6) \frac{\text{kN}}{\text{m}}$$

Total stiffness for the entire connection

Amount of steel

$$V_{plate} := n_p \cdot t \cdot b_t \cdot l_p = 0.021 \text{ m}^3$$

Volume of the plates

$$V_{dowels} := \pi \cdot \frac{d^2}{4} \cdot b_t \cdot n_{tot} = 0.004 \text{ m}^3$$

Volume of the dowels

$$V_{tot} := V_{plate} + V_{dowels} = 0.025 \text{ m}^3$$

Total volume

$$l_{ref} := 1.5 \text{ m}$$

Reference length

$$V_{timber} := b_t^2 \cdot l_{ref} - V_{tot} = 1.058 \text{ m}^3$$

Volume of the timber without the steel

$$\frac{V_{tot}}{V_{timber}} = 0.02395$$

Ratio steel and timber

A.2 Hand calculations for connection with external steel plates

External steel plates

Controls are marked with blue

Utilisation ratios are marked with green

Variables marked with yellow depends on the connection and are changed depending on the design

$$F := 5129 \text{ kN}$$

maximum normal force from Grasshopper

Geometry

Steel plate

$$t := 10 \text{ mm}$$

$$b := 850 \text{ mm}$$

$$h := \frac{3250}{2} \text{ mm} = 1.625 \text{ m}$$

$$t_1 := \frac{b_t - t}{2} = 424.995 \text{ m}$$

Glulam GL30h

$$b_t := 850 \text{ m}$$

$$t_2 := b_t = 850 \text{ m}$$

Largest dimensions of beam according to 2021

Maximum length of the steel plate

Bolts

$$d := 10 \text{ mm}$$

$$d_{ul} := \frac{d}{mm} = 10$$

Control := $\left\{ \begin{array}{l} \text{if } t > 0.3 \cdot d \\ \quad \left\{ \begin{array}{l} \text{"ok"} \\ \text{else} \\ \text{"increase thickness of steel or reduce diameter of fastener"} \end{array} \right. \\ \end{array} \right. = \text{"ok"}$

Material properties

Steel

$$f_{yk} := 460 \text{ MPa}$$

$$\gamma_M := 1.0$$

$$f_{yd} := \frac{f_{yk}}{\gamma_M} = 460 \text{ MPa}$$

Glulam GL30h

$$\rho_k := 490 \frac{\text{kg}}{\text{m}^3}$$

$$\rho_{k,ul} := 490$$

$$f_{c,90k} := 2.5 \text{ MPa}$$

Fastener strength

$$f_u := 800 \text{ MPa}$$

Fastener strength class 8.8

Embedment strength

$$M_{y.Rk} := \frac{f_u}{600} \cdot 180 \cdot d^{2.6} \cdot \text{mm}^{0.4} = 95.546 \text{ N} \cdot \text{m}$$

$$f_{h.k} := 0.082 \cdot (1 - 0.01 d_{ul}) \cdot \rho_{k.ul} = 36.162 \quad f_{h.k} := f_{h.k} \cdot \text{MPa} = 36.162 \text{ MPa}$$

Withdrawal capacity

$$D_{washer} := \min(12 \cdot t, 4 \cdot d) = 0.04 \text{ m}$$

$$A_{washer} := \pi \cdot \frac{(D_{washer}^2 - d^2)}{4} = (1.178 \cdot 10^3) \text{ mm}^2$$

$$F_{ax.washer} := 3 \cdot A_{washer} \cdot f_{c.90k} = 8.836 \text{ kN}$$

Shear capacity, characteristic value

Joint := "single"

Choose either "single" or "double"

$$F_{v.Rk.1} := 0.5 f_{h.k} \cdot t_2 \cdot d = (1.537 \cdot 10^5) \text{ kN}$$

$$F_{v.Rk.2} := \left\{ \begin{array}{l} \text{if } t \leq 0.5 d \\ \left\| \begin{array}{l} 1.15 \cdot \sqrt{2 M_{y.Rk} \cdot f_{h.k} \cdot d} \\ \text{if } t \geq d \\ \left\| \begin{array}{l} 2.3 \cdot \sqrt{M_{y.Rk} \cdot f_{h.k} \cdot d} \\ \text{if } 0.5 \cdot d < t < d \\ \left\| \begin{array}{l} 1.15 \cdot \sqrt{2 \cdot M_{y.Rk} \cdot f_{h.k} \cdot d} \\ + \left(\frac{2.3 \cdot \sqrt{M_{y.Rk} \cdot f_{h.k} \cdot d} - 1.15 \cdot \sqrt{2 \cdot M_{y.Rk} \cdot f_{h.k} \cdot d}}{d - 0.5 \cdot d} \right) \cdot (t - 0.5 \cdot d) \end{array} \right. \end{array} \right. \end{array} \right. \right. = 13.519 \text{ kN}$$

Rope effect

$fastener := \text{"dowels"}$

Choose either "bolts" or "dowels"

$$p_{fastener} := \begin{cases} \text{if } fastener = \text{"bolts"} \\ \quad \parallel 0.25 \\ \text{if } fastener = \text{"dowels"} \\ \quad \parallel 0 \end{cases} = 0$$

$$F_{ax.2} := \min\left(\frac{F_{ax.washer}}{4}, F_{v.Rk.2} \cdot p_{fastener}\right) = 0 \text{ kN}$$

$$F_{v.Rk.2} := F_{v.Rk.2} + F_{ax.2} = 13.519 \text{ kN}$$

$$F_{v.Rk} := \min(F_{v.Rk.1}, F_{v.Rk.2}) = 13.519 \text{ kN}$$

Shear capacity, design value

$$\gamma_M := 1.3$$

Timber connections

$$k_{mod} := 0.65$$

Load duration class M,
service class 3

$$F_{Rd} := \frac{k_{mod} \cdot F_{v.Rk}}{\gamma_M} = 6.76 \text{ kN}$$

Connection layout

$\alpha := 0 \text{ deg}$

angle of fastener

$end := \text{"loaded"}$

loaded or unloaded

$edge := \text{"loaded"}$

$$a_1 := \begin{cases} \text{if } fastener = \text{"bolts"} \\ \quad \parallel (4 + |\cos(\alpha)|) \cdot d \\ \text{if } fastener = \text{"dowels"} \\ \quad \parallel (3 + 2 |\cos(\alpha)|) \cdot d \end{cases} = 0.05 \text{ m}$$

Minimum spacing parallel to
grain

$$a_2 := \begin{cases} \text{if } fastener = \text{"bolts"} \\ \quad \parallel 4 \cdot d \\ \text{if } fastener = \text{"dowels"} \\ \quad \parallel 3 \cdot d \end{cases} = 0.03 \text{ m}$$

Minimum spacing
perpendicular to grain

$$a_3 := \begin{cases} \text{if } fastener = \text{"bolts"} & \\ \quad \text{if } end = \text{"loaded"} & \\ \quad \quad \max(7 \cdot d, 80 \text{ mm}) & \\ \quad \text{if } end = \text{"unloaded"} & \\ \quad \quad \text{if } 90 \text{ deg} \leq \alpha < 150 \text{ deg} & \\ \quad \quad \quad (1 + 6 \sin(\alpha)) \cdot d & \\ \quad \quad \text{if } 150 \text{ deg} \leq \alpha < 210 \text{ deg} & \\ \quad \quad \quad 4 \cdot d & \\ \quad \quad \text{if } 210 \text{ deg} \leq \alpha \leq 270 \text{ deg} & \\ \quad \quad \quad (1 + 6 |\sin(\alpha)|) \cdot d & \\ \text{if } fastener = \text{"dowels"} & \\ \quad \text{if } end = \text{"loaded"} & \\ \quad \quad \max(7 \cdot d, 80 \text{ mm}) & \\ \quad \text{if } end = \text{"unloaded"} & \\ \quad \quad \text{if } 90 \text{ deg} \leq \alpha < 150 \text{ deg} & \\ \quad \quad \quad \max(7 \cdot d, 80 \text{ mm}) |\sin(\alpha)| & \\ \quad \quad \text{if } 150 \text{ deg} \leq \alpha < 210 \text{ deg} & \\ \quad \quad \quad \max(3.5 \cdot d, 40 \text{ mm}) & \\ \quad \quad \text{if } 210 \text{ deg} \leq \alpha \leq 270 \text{ deg} & \\ \quad \quad \quad \max(7 \cdot d, 80 \text{ mm}) |\sin(\alpha)| & \\ \quad \quad \text{if } 0 \text{ deg} \leq \alpha < 90 \text{ deg} & \\ \quad \quad \quad \text{"invalid } \alpha & \\ \quad \quad \text{if } 270 \text{ deg} < \alpha \leq 360 \text{ deg} & \\ \quad \quad \quad \text{"invalid } \alpha & \end{cases} = 0.08 \text{ m}$$

Minimum spacing to end

-90 deg < alpha < 90 deg means loaded end

$$a_4 := \begin{cases} \text{if } edge = \text{"loaded"} & \\ \quad \max((2 + 2 \cdot \sin(\alpha)) \cdot d, 3 \cdot d) & \\ \text{if } edge = \text{"unloaded"} & \\ \quad 3 \cdot d & \end{cases} = 0.03 \text{ m}$$

Minimum spacing to edge

$$n_b := \frac{b - 2 \cdot a_4}{a_2} + 1 = 27.333$$

Maximum number of fastener along the width to fulfill minimum spacing

$$n_b := \text{trunc}(n_b) = 27$$

Chosen number of fastener along the width

$$n_h := 0$$

$$n_h^{0.9} \cdot \sqrt[4]{\frac{7 \cdot d}{13 \cdot d}} = \frac{F_{tension}}{F_{Rd} \cdot n_{row}}$$

Starting value for calculation of number of fasteners along the height

$$n_h := \left(\frac{F}{F_{Rd} \cdot n_b \cdot \sqrt[4]{\frac{7 \cdot d}{13 \cdot d}}} \right)^{\frac{1}{0.9}} = 48.349$$

$$n_h := \text{trunc}(n_h) + 1 = 49$$

$$n_{tot} := n_h \cdot n_b = 1.323 \cdot 10^3$$

Number of needed fasteners to reach the capacity

$$l_c := a_3 + (n_h - 1) \cdot a_1 + a_3 = 2.56 \text{ m}$$

$$n_{h,max} := \frac{h - 2 \cdot a_3}{a_1} + 1 = 30.3$$

$$n_{h,max} := \text{trunc}(n_{h,max}) = 30$$

Maximum number of fasteners along the length of the steel plate

$$\text{Control} := \begin{cases} \text{if } a_3 + (n_h - 1) \cdot a_1 + a_3 < h \\ \quad \text{"ok"} \\ \text{else} \\ \quad \text{"not ok"} \end{cases} = \text{"not ok"}$$

Control if the needed amount of fasteners can take place in the steel plate

$$\text{Control} := \begin{cases} \text{if } n_{h,max} \cdot n_b \cdot F_{Rd} > F \\ \quad \text{"ok"} \\ \text{if } n_{h,max} \cdot n_b \cdot F_{Rd} < F \\ \quad \text{"not ok"} \end{cases} = \text{"ok"}$$

$$\frac{F}{n_{h,max}^{0.9} \cdot \sqrt[4]{\frac{7 \cdot d}{13 \cdot d}} \cdot n_b \cdot F_{Rd}} = 1.537$$

Utilization ratio when using the maximum number of fasteners that can fit in the steel plate

A.3 Hand calculations for connection with external timber plates

External timber plates

Controls are marked with blue

Utilisation ratios are marked with green

Variables marked with yellow depends on the connection and are changed depending on the design

$$F := 5129 \text{ kN}$$

maximum normal force from Grasshopper

Geometry

Timber plate

$$t_1 := 40 \text{ mm}$$

$$t_2 := 850 \text{ mm}$$

$$b := 850 \text{ mm}$$

$$h := 1625 \text{ mm}$$

Largest dimensions of beam according to part 2

Bolts

$$d := 10 \text{ mm}$$

$$d_{ul} := \frac{d}{mm} = 10$$

Material properties

Timber 1

Timber 2

Glulam GL30h

Glulam GL30h

$$\rho_{k.1} := 490 \frac{\text{kg}}{\text{m}^3}$$

$$\rho_{k.1.ul} := 490$$

$$\rho_{k.2} := 490 \frac{\text{kg}}{\text{m}^3}$$

$$\rho_{k.2.ul} := 490$$

$$f_{c.90k} := 2.5 \text{ MPa}$$

$$f_{c.90k} := 2.5 \text{ MPa}$$

Fastener strength

$$f_u := 800 \text{ MPa}$$

Fastener strength class 8.8

Embedment strength

$$M_{y.Rk} := \frac{f_u}{600} \cdot 180 \cdot d^{2.6} \cdot \text{mm}^{0.4} = 95.546 \text{ N} \cdot \text{m}$$

$$f_{h.1.k} := 0.082 \cdot (1 - 0.01 d_{ul}) \cdot \rho_{k.1.ul} = 36.162 \quad f_{h.1.k} := f_{h.1.k} \cdot \text{MPa} = 36.162 \text{ MPa}$$

$$f_{h.2.k} := 0.082 \cdot (1 - 0.01 d_{ul}) \cdot \rho_{k.2.ul} = 36.162 \quad f_{h.2.k} := f_{h.2.k} \cdot \text{MPa} = 36.162 \text{ MPa}$$

$$\beta := \frac{f_{h.2.k}}{f_{h.1.k}} = 1$$

Withdrawal capacity

$$D_{washer} := \min(12 \cdot t_1, 4 \cdot d) = 0.04 \text{ m}$$

$$A_{washer} := \pi \cdot \frac{(D_{washer}^2 - d^2)}{4} = (1.178 \cdot 10^3) \text{ mm}^2$$

$$F_{ax.washer} := 3 \cdot A_{washer} \cdot f_{c.90k} = 8.836 \text{ kN}$$

Shear capacity, characteristic value

Joint := "double"

Choose either "single" or "double"

$$F_{v.Rk.1} := f_{h.1.k} \cdot t_1 \cdot d = 14.465 \text{ kN}$$

$$F_{v.Rk.2} := \begin{cases} \text{if Joint = "single"} & = 153.689 \text{ kN} \\ \left\| \begin{array}{l} f_{h.2.k} \cdot t_2 \cdot d \\ \text{if Joint = "double"} \\ 0.5 f_{h.2.k} \cdot t_2 \cdot d \end{array} \right\| \end{cases}$$

$$F_{v.Rk.3} := \begin{cases} \text{if Joint = "single"} & = 7.319 \text{ kN} \\ \left\| \begin{array}{l} \frac{f_{h.1.k} \cdot t_1 \cdot d}{1 + \beta} \cdot \left(\sqrt{\beta + 2 \cdot \beta^2 \left(1 + \frac{t_2}{t_1} + \left(\frac{t_2}{t_1} \right)^2} \right) + \beta^3 \cdot \left(\frac{t_2}{t_1} \right)^2} - \beta \cdot \left(1 + \frac{t_2}{t_1} \right) \right) \\ \text{if Joint = "double"} \\ 1.05 \frac{f_{h.1.k} \cdot t_1 \cdot d}{2 + \beta} \cdot \left(\sqrt{2 \cdot \beta \cdot (1 + \beta) + \frac{4 \beta \cdot (2 + \beta) M_{y.Rk}}{f_{h.1.k} \cdot d \cdot t_1^2}} - \beta \right) \end{array} \right\| \end{cases}$$

$$F_{v.Rk.4} := \begin{cases} \text{if Joint = "single"} & = 9.56 \text{ kN} \\ \left\| \begin{array}{l} 1.05 \frac{f_{h.1.k} \cdot t_1 \cdot d}{2 + \beta} \cdot \left(\sqrt{2 \cdot \beta \cdot (1 + \beta) + \frac{4 \beta \cdot (2 + \beta) M_{y.Rk}}{f_{h.1.k} \cdot d \cdot t_1^2}} - \beta \right) \end{array} \right\| \end{cases}$$

$$\begin{cases} \text{if } Joint = \text{"double"} \\ 1.15 \cdot \sqrt{\frac{2\beta}{1+\beta}} \cdot \sqrt{2 \cdot M_{y.Rk} \cdot f_{h.1.k} \cdot d} \end{cases}$$

$$F_{v.Rk.5} := \begin{cases} \text{if } Joint = \text{"single"} \\ 1.05 \frac{f_{h.1.k} \cdot t_2 \cdot d}{1+2\beta} \cdot \left(\sqrt{2 \cdot \beta^2 \cdot (1+\beta) + \frac{4\beta \cdot (1+\beta) M_{y.Rk}}{f_{h.1.k} \cdot d \cdot t_2^2}} - \beta \right) \\ \text{if } Joint = \text{"double"} \\ 0 \text{ kN} \end{cases} = 0 \text{ kN}$$

$$F_{v.Rk.6} := \begin{cases} \text{if } Joint = \text{"single"} \\ 1.15 \cdot \sqrt{\frac{2\beta}{1+\beta}} \cdot \sqrt{2 \cdot M_{y.Rk} \cdot f_{h.1.k} \cdot d} \\ \text{if } Joint = \text{"double"} \\ 0 \text{ kN} \end{cases}$$

Rope effect

fastener := "bolts"

Choose either "bolts" or "dowels"

$$p_{fastener} := \begin{cases} \text{if } fastener = \text{"bolts"} \\ 0.25 \\ \text{if } fastener = \text{"dowels"} \\ 0 \end{cases} = 0.25$$

$$F_{ax.3} := \min \left(\frac{F_{ax.washer}}{4}, F_{v.Rk.3} \cdot p_{fastener} \right) = 1.83 \text{ kN}$$

$$F_{ax.4} := \min \left(\frac{F_{ax.washer}}{4}, F_{v.Rk.4} \cdot p_{fastener} \right) = 2.209 \text{ kN}$$

$$F_{ax.5} := \min \left(\frac{F_{ax.washer}}{4}, F_{v.Rk.5} \cdot p_{fastener} \right) = 0 \text{ kN}$$

$$F_{ax.6} := \min \left(\frac{F_{ax.washer}}{4}, F_{v.Rk.6} \cdot p_{fastener} \right) = 0 \text{ kN}$$

$$F_{v.Rk.3} := F_{v.Rk.3} + F_{ax.3} = 9.149 \text{ kN}$$

$$F_{v.Rk.4} := F_{v.Rk.4} + F_{ax.4} = 11.769 \text{ kN}$$

$$F_{v.Rk.5} := F_{v.Rk.5} + F_{ax.5} = 0 \text{ kN}$$

$$F_{v.Rk.6} := F_{v.Rk.6} + F_{ax.6} = 0 \text{ kN}$$

$$F_{v.Rk} := \begin{cases} \text{if } Joint = \text{"single"} \\ \quad \left\| \min(F_{v.Rk.1}, F_{v.Rk.2}, F_{v.Rk.3}, F_{v.Rk.4}, F_{v.Rk.5}, F_{v.Rk.6}) \right\| \\ \text{if } Joint = \text{"double"} \\ \quad \left\| \min(F_{v.Rk.1}, F_{v.Rk.2}, F_{v.Rk.3}, F_{v.Rk.4}) \right\| \end{cases} = 9.149 \text{ kN}$$

Shear capacity, design value

$$\gamma_M := 1.3$$

Timber connections

$$k_{mod} := 0.65$$

Load duration class M,
service class 3

$$F_{Rd} := \frac{k_{mod} \cdot F_{v.Rk}}{\gamma_M} = 4.575 \text{ kN}$$

Connection layout

$$\alpha := 0 \text{ deg}$$

angle of fastener

$$end := \text{"loaded"}$$

loaded or unloaded

$$edge := \text{"loaded"}$$

$$a_1 := \begin{cases} \text{if } fastener = \text{"bolts"} \\ \quad \left\| (4 + |\cos(\alpha)|) \cdot d \right\| \\ \text{if } fastener = \text{"dowels"} \\ \quad \left\| (3 + 2 |\cos(\alpha)|) \cdot d \right\| \end{cases} = 0.05 \text{ m}$$

Minimum spacing parallel to
grain

$$a_2 := \begin{cases} \text{if } fastener = \text{"bolts"} \\ \quad \left\| 4 \cdot d \right\| \\ \text{if } fastener = \text{"dowels"} \\ \quad \left\| 3 \cdot d \right\| \end{cases} = 0.04 \text{ m}$$

Minimum spacing
perpendicular to grain

$$a_3 := \begin{cases} \text{if } fastener = \text{"bolts"} \\ \quad \left\| \begin{cases} \text{if } end = \text{"loaded"} \\ \quad \left\| \max(7 \cdot d, 80 \text{ mm}) \right\| \\ \text{if } end = \text{"unloaded"} \\ \quad \left\| \begin{cases} \text{if } 90 \text{ deg} \leq \alpha < 150 \text{ deg} \\ \quad \left\| (1 + 6 \sin(\alpha)) \cdot d \right\| \\ \text{if } 150 \text{ deg} \leq \alpha < 210 \text{ deg} \\ \quad \left\| 4 \cdot d \right\| \\ \text{if } 210 \text{ deg} \leq \alpha \leq 270 \text{ deg} \\ \quad \left\| (1 + 6 |\sin(\alpha)|) \cdot d \right\| \end{cases} \right\| \end{cases} \right\| \end{cases} = 0.08 \text{ m}$$

Minimum spacing to end

-90 deg < alpha < 90 deg
means loaded end

```

if fastener = "dowels"
  if end = "loaded"
    || max(7 · d, 80 mm)
  if end = "unloaded"
    if 90 deg ≤ α < 150 deg
      || max(7 · d, 80 mm) |sin(α)|
    if 150 deg ≤ α < 210 deg
      || max(3.5 · d, 40 mm)
    if 210 deg ≤ α ≤ 270 deg
      || max(7 · d, 80 mm) |sin(α)|
    if 0 deg ≤ α < 90 deg
      || "invalid α"
    if 270 deg < α ≤ 360 deg
      || "invalid α"

```

$$a_4 := \begin{cases} \text{if } edge = \text{"loaded"} \\ \quad || \max((2 + 2 \cdot \sin(\alpha)) \cdot d, 3 \cdot d) \\ \text{if } edge = \text{"unloaded"} \\ \quad || 3 \cdot d \end{cases} = 0.03 \text{ m} \quad \text{Minimum spacing to edge}$$

$$n_b := \frac{b - 2 \cdot a_4}{a_2} + 1 = 20.75 \quad \text{Maximum number of rows to full minimum spacing}$$

$$n_b := \text{trunc}(n_b) = 20 \quad \text{Chosen number of rows}$$

$$n := 0 \quad \text{Starting value for calculation of number of fasteners in one row}$$

$$n_b^{0.9} \cdot \sqrt[4]{\frac{7 \cdot d}{13 \cdot d}} = \frac{F_{tension}}{F_{Rd} \cdot n_{row}}$$

$$n_h := \left(\frac{F}{F_{Rd} \cdot n_b \cdot \sqrt[4]{\frac{7 \cdot d}{13 \cdot d}}} \right)^{\frac{1}{0.9}} = 104.142$$

$$n_h := \text{trunc}(n_h) + 1 = 105$$

$$n_{tot} := n_h \cdot n_b = 2.1 \cdot 10^3 \quad \text{Number of needed fasteners to reach the capacity}$$

$$l_c := a_3 + (n_h - 1) \cdot a_1 + a_3 = 5.36 \text{ m}$$

$$n_{h.max} := \frac{h - 2 \cdot a_3}{a_1} + 1 = 30.3$$

$$n_{h.max} := \text{trunc}(n_{h.max}) = 30$$

Maximum number of fasteners along the length of the steel plate

$$\text{Control} := \begin{cases} \text{if } a_3 + (n_h - 1) \cdot a_1 + a_3 < h \\ \quad \text{"ok"} \\ \text{else} \\ \quad \text{"not ok"} \end{cases} = \text{"not ok"}$$

Control if the needed amount of fasteners can take place in the steel plate

$$\text{Control} := \begin{cases} \text{if } n_h \cdot n_b \cdot F_{Rd} > F \\ \quad \text{"ok"} \\ \text{if } n_h \cdot n_b \cdot F_{Rd} < F \\ \quad \text{"not ok"} \end{cases} = \text{"ok"}$$

$$\frac{F}{n_{h.max}^{0.9} \cdot \sqrt[4]{\frac{7 \cdot d}{13 \cdot d} \cdot n_b \cdot F_{Rd}}} = 3.065$$

Utilization ratio when using the maximum number of fasteners that can fit in the steel plate

A.4 Hand calculations for connection with glued-in rods

Glued-in rods

Controls are marked with blue

Utilisation ratios are marked with green

Variables marked with yellow depends on the connection and are changed depending on the design

$$F := 5129 \text{ kN}$$

maximum normal force from Grasshopper

Geometry

$$d := 20 \text{ mm}$$

$$s := \text{"M20"}$$

$$\text{climate} := 1$$

$$b := 850 \text{ mm}$$

$$h := 850 \text{ mm}$$

Material properties

$$f_u := 800 \text{ MPa}$$

$$A_s := \pi \cdot \frac{d^2}{4} = 314.159 \text{ mm}^2$$

$$n_{\text{rods}} := 13$$

$$\gamma_M := 1.3$$

for timber connections

$$k_{\text{mod}} := 0.65$$

Load duration class M,
service class 3

Capacity

Load-bearing capacity for rods in tension, characteristic value

$$F_{v.Rk.rod} := 0.6 \cdot f_u \cdot A_s \cdot n_{rods} = (1.96 \cdot 10^3) \text{ kN}$$

$$k_1 := \begin{cases} \text{if } s = \text{"M10"} & = 0.69 \\ & \parallel 0.55 \\ \text{if } s = \text{"M12"} & \\ & \parallel 0.59 \\ \text{if } s = \text{"M16"} & \\ & \parallel 0.64 \\ \text{if } s = \text{"M20"} & \\ & \parallel 0.69 \end{cases}$$

$$\kappa_1 := \begin{cases} \text{if } climate = 1 & = 1 \\ & \parallel 1 \\ \text{if } climate = 2 & \\ & \parallel 0.85 \end{cases}$$

$$f_{ax.k} := 40 \text{ MPa}$$

$$l_i := 450 \text{ mm}$$

Withdrawal capacity timber, characteristic value

$$F_{v.Rk.timber} := \pi \cdot (d + 1 \text{ mm}) \cdot l_i \cdot f_{ax.k} \cdot k_1 \cdot \kappa_1 = 819.39 \text{ kN}$$

Load-bearing capacity for rods in tension, design value

$$F_{v.Rd.rod} := n_{rods} \cdot F_{v.Rk.rod} \cdot \left(\frac{1}{1.2} \right) = (2.124 \cdot 10^4) \text{ kN}$$

Withdrawal capacity timber, design value

$$F_{v.Rd.timber} := F_{v.Rk.timber} \cdot \left(\frac{k_{mod}}{\gamma_M} \right) = 409.695 \text{ kN}$$

Connection layout

$$a_1 := 4 \cdot d = 0.08 \text{ m}$$

Min distance between rods

$$a_2 := 2.5 d = 0.05 \text{ m}$$

Min distance to edge

$$n_{b,max} := \frac{b - 2 \cdot a_2}{a_1} = 9.375$$

$$n_{b,max} := \text{trunc}(n_{b,max}) = 9$$

$$n_b := 4$$

$$n_h := \frac{n_{rods}}{n_b} = 3.25$$

$$n_h := \text{trunc}(n_h) + 1 = 4$$

$$n_{tot} := n_h \cdot n_b = 16$$

$$\text{Control} := \left\| \begin{array}{l} \text{if } F_{v.Rd.rod} > F \\ \quad \text{"ok"} \\ \text{if } F_{v.Rd.rod} < F \\ \quad \text{"not ok"} \end{array} \right\| = \text{"ok"}$$

Utilization ratio

$$\frac{F}{n_{tot} \cdot F_{v.Rd.timber}} = 0.782$$

$$\text{Control} := \left\| \begin{array}{l} \text{if } F_{v.Rd.timber} > \frac{F}{n_{tot}} \\ \quad \text{"ok"} \\ \text{if } F_{v.Rd.timber} < \frac{F}{n_{tot}} \\ \quad \text{"not ok"} \end{array} \right\| = \text{"ok"}$$

$$\frac{F}{F_{v.Rd.rod}} = 0.242$$

$$\text{Control} := \left\| \begin{array}{l} \text{if } (n_h - 1) \cdot a_1 + 2 \cdot a_2 \leq b \\ \quad \text{"ok"} \\ \text{if } (n_h - 1) \cdot a_1 + 2 \cdot a_2 \geq b \\ \quad \text{"not ok"} \end{array} \right\| = \text{"ok"}$$

$$\text{Control} := \left\| \begin{array}{l} \text{if } (n_b - 1) \cdot a_1 + 2 \cdot a_2 \leq h \\ \quad \text{"ok"} \\ \text{if } (n_b - 1) \cdot a_1 + 2 \cdot a_2 \geq h \\ \quad \text{"not ok"} \end{array} \right\| = \text{"ok"}$$

A.5 FEM-design code

The code for the FEM-design model of connection M is attached in this Appendix. The models of the other connections were designed in a similar way as this one.

```

<?xml version="1.0" encoding="UTF-8"?>
<!-- (c) StruSoft 2012-2021, http://www.strusoft.com -->
<database struxml_version="01.00.000" source_software="FEM-Design 21.00.001"
start_time="1970-01-01T00:00:00.000" end_time="2022-05-23T14:17:27.000"
guid="94a4fac5-d7ce-477f-8a89-a27407ded94b"
convertid="00000000-0000-0000-0000-000000000000" standard="EC" country="S"
xmlns="urn:strusoft">
  <entities>
    <slab name="P.1" guid="f351b208-6473-48ab-a938-c35a0a129cfa"
last_change="2022-05-23T14:17:27.000" action="added" type="plate">
      <slab_part guid="62bc4092-16e5-4861-8105-16a5b61c4c7d"
last_change="2022-05-23T14:17:27.000" action="added" name="P.1.1"
complex_material="99915fcb-e324-4e94-90bb-082b32a698f0" alignment="center"
align_offset="0" ortho_alfa="0" ortho_ratio="1">
        <contour>
          <edge type="line">
            <point x="0" y="0"
z="0"></point>
            <point x="0.31" y="0"
z="0"></point>
            <normal x="0" y="1"
z="0"></normal>
          </edge>
          <edge type="line">
            <point x="0.31" y="0"
z="0"></point>
            <point x="0.31" y="0.85"
z="0"></point>
            <normal x="-1" y="0"
z="0"></normal>
          </edge>
          <edge type="line">
            <point x="0.31" y="0.85"
z="0"></point>
            <point x="0" y="0.85"
z="0"></point>
            <normal x="0" y="-1"
z="0"></normal>
          </edge>
          <edge type="line">
            <point x="0" y="0.85"
z="0"></point>
            <point x="0" y="0"
z="0"></point>
            <normal x="1" y="0"
z="0"></normal>
          </edge>
        </contour>
        <thickness x="0" y="0" z="0"
val="0.086571"></thickness>
        <local_pos x="0.155" y="0.425"
z="0"></local_pos>
        <local_x x="1" y="0" z="0"></local_x>
        <local_y x="0" y="1" z="0"></local_y>

```

```

                <end></end>
            </slab_part>
        <end></end>
    </slab>
    <slab name="P.2" guid="24715490-7dbe-4697-8e16-ada243c42241"
last_change="2022-05-23T14:12:03.000" action="added" type="plate">
        <slab_part guid="80c55b4e-d9db-4f38-96e5-e10e1b4f29e4"
last_change="2022-05-23T14:12:03.000" action="added" name="P.2.1"
complex_material="60f80ee8-264c-4963-8bc2-2895cdd41db9" alignment="center"
align_offset="0" ortho_alfa="0" ortho_ratio="1">
            <contour>
                <edge type="line">
                    <point x="0.522080289525547"
y="0" z="0"></point>
                    <point x="0.832080289525547"
y="0" z="0"></point>
                    <normal x="0" y="1"
z="0"></normal>
                </edge>
                <edge type="line">
                    <point x="0.832080289525547"
y="0" z="0"></point>
                    <point x="0.832080289525547"
y="0.85" z="0"></point>
                    <normal x="-1" y="0"
z="0"></normal>
                </edge>
                <edge type="line">
                    <point x="0.832080289525547"
y="0.85" z="0"></point>
                    <point x="0.522080289525547"
y="0.85" z="0"></point>
                    <normal x="0" y="-1"
z="0"></normal>
                </edge>
                <edge type="line">
                    <point x="0.522080289525547"
y="0.85" z="0"></point>
                    <point x="0.522080289525547"
y="0" z="0"></point>
                    <normal x="1" y="0"
z="0"></normal>
                </edge>
            </contour>
            <thickness x="0.522080289525547" y="0" z="0"
val="0.01"></thickness>
            <local_pos x="0.677080289525547" y="0.425"
z="0"></local_pos>
            <local_x x="1" y="0" z="0"></local_x>
            <local_y x="0" y="1" z="0"></local_y>
        <end></end>
    </slab_part>
<end></end>
</slab>

```

```

        <loads>
            <line_load
load_case="1e2eb130-4acf-482c-888a-26dfba017808"
guid="52bdf754-c416-4652-88b3-be16a96c0220"
last_change="2022-05-23T14:14:24.000" action="added" load_dir="constant"
load_projection="false" load_type="force">
                <edge type="line">
                    <point x="0.832080289525547" y="0"
z="0"></point>
                    <point x="0.832080289525547" y="0.85"
z="0"></point>
                    <normal x="-1" y="0" z="0"></normal>
                </edge>
                <direction x="1" y="0" z="0"></direction>
                <normal x="0" y="0" z="1"></normal>
                <load x="0.832080289525547" y="0" z="0"
val="641.125"></load>
                <load x="0.832080289525547" y="0.85" z="0"
val="641.125"></load>
            </line_load>
            <load_case type="static" duration_class="medium-term"
guid="1e2eb130-4acf-482c-888a-26dfba017808"
last_change="2022-04-20T06:05:07.000" action="added" name="g"></load_case>
            <load_combination
guid="f730031f-f5af-47cd-8ecd-55519e953d80"
last_change="2022-04-20T06:05:18.000" action="added" name="Load"
type="ultimate_ordinary">
                <load_case
guid="1e2eb130-4acf-482c-888a-26dfba017808" gamma="1"></load_case>
            </load_combination>
        </loads>
        <supports>
            <line_support
guid="f44a6d3e-d170-41b7-8749-77c1f8bcf8d3"
last_change="2022-05-23T14:13:56.000" action="added" name="S.1">
                <group>
                    <local_x x="0" y="0" z="1"></local_x>
                    <local_y x="-1" y="0" z="0"></local_y>
                    <rigidity>
                        <motions x_neg="10000000"
x_pos="10000000" y_neg="10000000" y_pos="10000000" z_neg="10000000"
z_pos="10000000"></motions>
                        <rotations x_neg="0" x_pos="0"
y_neg="0" y_pos="0" z_neg="0" z_pos="0"></rotations>
                    </rigidity>
                </group>
                <edge type="line">
                    <point x="0" y="0" z="0"></point>
                    <point x="0" y="0.85" z="0"></point>
                    <normal x="-1" y="0" z="0"></normal>
                </edge>
                <normal x="0" y="0" z="1"></normal>
            </line_support>
        </supports>

```



```

    <advanced-fem>
      <connected_points
guid="2fd4a636-3388-4490-9074-75be9f56ad41"
last_change="2022-05-23T14:17:27.000" action="added" name="CP.1" interface="0">
  <point x="0.08" y="0.8" z="0"></point>
  <point x="0.602080289525547" y="0.8"
z="0"></point>
  <local_x x="1" y="0" z="0"></local_x>
  <local_y x="0" y="1" z="0"></local_y>
  <rigidity>
    <motions x_neg="6096" x_pos="6096"
y_neg="6096" y_pos="6096" z_neg="6096" z_pos="6096"></motions>
    <rotations x_neg="0" x_pos="0" y_neg="0"
y_pos="0" z_neg="0" z_pos="0"></rotations>
  </rigidity>
  <ref
guid="80c55b4e-d9db-4f38-96e5-e10e1b4f29e4"></ref>
  <ref
guid="62bc4092-16e5-4861-8105-16a5b61c4c7d"></ref>
  </connected_points>
  <connected_points
guid="cdb1d3eb-5bdf-4064-93c5-d0abae8cfef"
last_change="2022-05-23T14:17:27.000" action="added" name="CP.2" interface="0">
  <point x="0.13" y="0.8" z="0"></point>
  <point x="0.652080289525547" y="0.8"
z="0"></point>
  <local_x x="1" y="0" z="0"></local_x>
  <local_y x="0" y="1" z="0"></local_y>
  <rigidity>
    <motions x_neg="6096" x_pos="6096"
y_neg="6096" y_pos="6096" z_neg="6096" z_pos="6096"></motions>
    <rotations x_neg="0" x_pos="0" y_neg="0"
y_pos="0" z_neg="0" z_pos="0"></rotations>
  </rigidity>
  <ref
guid="80c55b4e-d9db-4f38-96e5-e10e1b4f29e4"></ref>
  <ref
guid="62bc4092-16e5-4861-8105-16a5b61c4c7d"></ref>
  </connected_points>
  <connected_points
guid="f2a3eda0-4fd0-415a-ad2c-73d430b00493"
last_change="2022-05-23T14:17:27.000" action="added" name="CP.3" interface="0">
  <point x="0.18" y="0.8" z="0"></point>
  <point x="0.702080289525547" y="0.8"
z="0"></point>
  <local_x x="1" y="0" z="0"></local_x>
  <local_y x="0" y="1" z="0"></local_y>
  <rigidity>
    <motions x_neg="6096" x_pos="6096"
y_neg="6096" y_pos="6096" z_neg="6096" z_pos="6096"></motions>
    <rotations x_neg="0" x_pos="0" y_neg="0"
y_pos="0" z_neg="0" z_pos="0"></rotations>
  </rigidity>
  <ref

```

```

guid="80c55b4e-d9db-4f38-96e5-e10e1b4f29e4"></ref>
  <ref
guid="62bc4092-16e5-4861-8105-16a5b61c4c7d"></ref>
  </connected_points>
  <connected_points
guid="305e8313-8437-475c-863e-0a29b8a09297"
last_change="2022-05-23T14:17:27.000" action="added" name="CP.4" interface="0">
  <point x="0.23" y="0.8" z="0"></point>
  <point x="0.752080289525547" y="0.8"
z="0"></point>
  <local_x x="1" y="0" z="0"></local_x>
  <local_y x="0" y="1" z="0"></local_y>
  <rigidity>
    <motions x_neg="6096" x_pos="6096"
y_neg="6096" y_pos="6096" z_neg="6096" z_pos="6096"></motions>
    <rotations x_neg="0" x_pos="0" y_neg="0"
y_pos="0" z_neg="0" z_pos="0"></rotations>
  </rigidity>
  <ref
guid="80c55b4e-d9db-4f38-96e5-e10e1b4f29e4"></ref>
  <ref
guid="62bc4092-16e5-4861-8105-16a5b61c4c7d"></ref>
  </connected_points>
  <connected_points
guid="528d0b25-9867-468f-a5ee-653f8e0cfb85"
last_change="2022-05-23T14:17:27.000" action="added" name="CP.5" interface="0">
  <point x="0.08" y="0.75" z="0"></point>
  <point x="0.602080289525547" y="0.75"
z="0"></point>
  <local_x x="1" y="0" z="0"></local_x>
  <local_y x="0" y="1" z="0"></local_y>
  <rigidity>
    <motions x_neg="6096" x_pos="6096"
y_neg="6096" y_pos="6096" z_neg="6096" z_pos="6096"></motions>
    <rotations x_neg="0" x_pos="0" y_neg="0"
y_pos="0" z_neg="0" z_pos="0"></rotations>
  </rigidity>
  <ref
guid="80c55b4e-d9db-4f38-96e5-e10e1b4f29e4"></ref>
  <ref
guid="62bc4092-16e5-4861-8105-16a5b61c4c7d"></ref>
  </connected_points>
  <connected_points
guid="89d125b6-8113-40fc-819a-80ab9b8c7315"
last_change="2022-05-23T14:17:27.000" action="added" name="CP.6" interface="0">
  <point x="0.13" y="0.75" z="0"></point>
  <point x="0.652080289525547" y="0.75"
z="0"></point>
  <local_x x="1" y="0" z="0"></local_x>
  <local_y x="0" y="1" z="0"></local_y>
  <rigidity>
    <motions x_neg="6096" x_pos="6096"
y_neg="6096" y_pos="6096" z_neg="6096" z_pos="6096"></motions>
    <rotations x_neg="0" x_pos="0" y_neg="0"

```

```

y_pos="0" z_neg="0" z_pos="0"></rotations>
      </rigidity>
      <ref
guid="80c55b4e-d9db-4f38-96e5-e10e1b4f29e4"></ref>
      <ref
guid="62bc4092-16e5-4861-8105-16a5b61c4c7d"></ref>
      </connected_points>
      <connected_points
guid="32c32c3f-06a7-4884-9e33-e6cd7c3c4950"
last_change="2022-05-23T14:17:27.000" action="added" name="CP.7" interface="0">
      <point x="0.18" y="0.75" z="0"></point>
      <point x="0.702080289525547" y="0.75"
z="0"></point>
      <local_x x="1" y="0" z="0"></local_x>
      <local_y x="0" y="1" z="0"></local_y>
      <rigidity>
      <motions x_neg="6096" x_pos="6096"
y_neg="6096" y_pos="6096" z_neg="6096" z_pos="6096"></motions>
      <rotations x_neg="0" x_pos="0" y_neg="0"
y_pos="0" z_neg="0" z_pos="0"></rotations>
      </rigidity>
      <ref
guid="80c55b4e-d9db-4f38-96e5-e10e1b4f29e4"></ref>
      <ref
guid="62bc4092-16e5-4861-8105-16a5b61c4c7d"></ref>
      </connected_points>
      <connected_points
guid="46f6e1bd-d9a6-4944-9964-2ed4aa3f5343"
last_change="2022-05-23T14:17:27.000" action="added" name="CP.8" interface="0">
      <point x="0.23" y="0.75" z="0"></point>
      <point x="0.752080289525547" y="0.75"
z="0"></point>
      <local_x x="1" y="0" z="0"></local_x>
      <local_y x="0" y="1" z="0"></local_y>
      <rigidity>
      <motions x_neg="6096" x_pos="6096"
y_neg="6096" y_pos="6096" z_neg="6096" z_pos="6096"></motions>
      <rotations x_neg="0" x_pos="0" y_neg="0"
y_pos="0" z_neg="0" z_pos="0"></rotations>
      </rigidity>
      <ref
guid="80c55b4e-d9db-4f38-96e5-e10e1b4f29e4"></ref>
      <ref
guid="62bc4092-16e5-4861-8105-16a5b61c4c7d"></ref>
      </connected_points>
      <connected_points
guid="89b8b178-92aa-4797-afd5-72bf79cc0c49"
last_change="2022-05-23T14:17:27.000" action="added" name="CP.9" interface="0">
      <point x="0.08" y="0.7" z="0"></point>
      <point x="0.602080289525547" y="0.7"
z="0"></point>
      <local_x x="1" y="0" z="0"></local_x>
      <local_y x="0" y="1" z="0"></local_y>
      <rigidity>

```

```

        <motions x_neg="6096" x_pos="6096"
y_neg="6096" y_pos="6096" z_neg="6096" z_pos="6096"></motions>
        <rotations x_neg="0" x_pos="0" y_neg="0"
y_pos="0" z_neg="0" z_pos="0"></rotations>
        </rigidity>
        <ref
guid="80c55b4e-d9db-4f38-96e5-e10e1b4f29e4"></ref>
        <ref
guid="62bc4092-16e5-4861-8105-16a5b61c4c7d"></ref>
        </connected_points>
        <connected_points
guid="27871fa9-dd41-46af-aebc-ed2f3133b874"
last_change="2022-05-23T14:17:27.000" action="added" name="CP.10" interface="0">
        <point x="0.13" y="0.7" z="0"></point>
        <point x="0.652080289525547" y="0.7"
z="0"></point>
        <local_x x="1" y="0" z="0"></local_x>
        <local_y x="0" y="1" z="0"></local_y>
        <rigidity>
        <motions x_neg="6096" x_pos="6096"
y_neg="6096" y_pos="6096" z_neg="6096" z_pos="6096"></motions>
        <rotations x_neg="0" x_pos="0" y_neg="0"
y_pos="0" z_neg="0" z_pos="0"></rotations>
        </rigidity>
        <ref
guid="80c55b4e-d9db-4f38-96e5-e10e1b4f29e4"></ref>
        <ref
guid="62bc4092-16e5-4861-8105-16a5b61c4c7d"></ref>
        </connected_points>
        <connected_points
guid="8194a08d-559e-44d8-87a8-9dfa4ce8248e"
last_change="2022-05-23T14:17:27.000" action="added" name="CP.11" interface="0">
        <point x="0.18" y="0.7" z="0"></point>
        <point x="0.702080289525547" y="0.7"
z="0"></point>
        <local_x x="1" y="0" z="0"></local_x>
        <local_y x="0" y="1" z="0"></local_y>
        <rigidity>
        <motions x_neg="6096" x_pos="6096"
y_neg="6096" y_pos="6096" z_neg="6096" z_pos="6096"></motions>
        <rotations x_neg="0" x_pos="0" y_neg="0"
y_pos="0" z_neg="0" z_pos="0"></rotations>
        </rigidity>
        <ref
guid="80c55b4e-d9db-4f38-96e5-e10e1b4f29e4"></ref>
        <ref
guid="62bc4092-16e5-4861-8105-16a5b61c4c7d"></ref>
        </connected_points>
        <connected_points
guid="6bddbebc-2407-479d-8e70-e16ff02d0aa3"
last_change="2022-05-23T14:17:27.000" action="added" name="CP.12" interface="0">
        <point x="0.23" y="0.7" z="0"></point>
        <point x="0.752080289525547" y="0.7"
z="0"></point>

```

```
<local_x x="1" y="0" z="0"></local_x>
<local_y x="0" y="1" z="0"></local_y>
<rigidity>
  <motions x_neg="6096" x_pos="6096"
y_neg="6096" y_pos="6096" z_neg="6096" z_pos="6096"></motions>
  <rotations x_neg="0" x_pos="0" y_neg="0"
y_pos="0" z_neg="0" z_pos="0"></rotations>
</rigidity>
<ref
guid="80c55b4e-d9db-4f38-96e5-e10e1b4f29e4"></ref>
<ref
guid="62bc4092-16e5-4861-8105-16a5b61c4c7d"></ref>
</connected_points>
<connected_points
guid="7be1a61f-6b5a-462c-aa80-686b91e81699"
last_change="2022-05-23T14:17:27.000" action="added" name="CP.13" interface="0">
  <point x="0.08" y="0.65" z="0"></point>
  <point x="0.602080289525547" y="0.65"
z="0"></point>
  <local_x x="1" y="0" z="0"></local_x>
  <local_y x="0" y="1" z="0"></local_y>
  <rigidity>
    <motions x_neg="6096" x_pos="6096"
y_neg="6096" y_pos="6096" z_neg="6096" z_pos="6096"></motions>
    <rotations x_neg="0" x_pos="0" y_neg="0"
y_pos="0" z_neg="0" z_pos="0"></rotations>
  </rigidity>
  <ref
guid="80c55b4e-d9db-4f38-96e5-e10e1b4f29e4"></ref>
  <ref
guid="62bc4092-16e5-4861-8105-16a5b61c4c7d"></ref>
  </connected_points>
  <connected_points
guid="38045618-28a5-4660-ab08-03cf55bb0ff9"
last_change="2022-05-23T14:17:27.000" action="added" name="CP.14" interface="0">
  <point x="0.13" y="0.65" z="0"></point>
  <point x="0.652080289525547" y="0.65"
z="0"></point>
  <local_x x="1" y="0" z="0"></local_x>
  <local_y x="0" y="1" z="0"></local_y>
  <rigidity>
    <motions x_neg="6096" x_pos="6096"
y_neg="6096" y_pos="6096" z_neg="6096" z_pos="6096"></motions>
    <rotations x_neg="0" x_pos="0" y_neg="0"
y_pos="0" z_neg="0" z_pos="0"></rotations>
  </rigidity>
  <ref
guid="80c55b4e-d9db-4f38-96e5-e10e1b4f29e4"></ref>
  <ref
guid="62bc4092-16e5-4861-8105-16a5b61c4c7d"></ref>
  </connected_points>
  <connected_points
guid="110c048f-fe56-4ebd-b455-5cc015f7f476"
last_change="2022-05-23T14:17:27.000" action="added" name="CP.15" interface="0">
```

```
<point x="0.18" y="0.65" z="0"></point>
<point x="0.702080289525547" y="0.65"
z="0"></point>
<local_x x="1" y="0" z="0"></local_x>
<local_y x="0" y="1" z="0"></local_y>
<rigidity>
  <motions x_neg="6096" x_pos="6096"
y_neg="6096" y_pos="6096" z_neg="6096" z_pos="6096"></motions>
  <rotations x_neg="0" x_pos="0" y_neg="0"
y_pos="0" z_neg="0" z_pos="0"></rotations>
</rigidity>
<ref
guid="80c55b4e-d9db-4f38-96e5-e10e1b4f29e4"></ref>
<ref
guid="62bc4092-16e5-4861-8105-16a5b61c4c7d"></ref>
</connected_points>
<connected_points
guid="d0bb382d-70ec-4f78-b497-13a57ae213a9"
last_change="2022-05-23T14:17:27.000" action="added" name="CP.16" interface="0">
  <point x="0.23" y="0.65" z="0"></point>
  <point x="0.752080289525547" y="0.65"
z="0"></point>
  <local_x x="1" y="0" z="0"></local_x>
  <local_y x="0" y="1" z="0"></local_y>
  <rigidity>
    <motions x_neg="6096" x_pos="6096"
y_neg="6096" y_pos="6096" z_neg="6096" z_pos="6096"></motions>
    <rotations x_neg="0" x_pos="0" y_neg="0"
y_pos="0" z_neg="0" z_pos="0"></rotations>
  </rigidity>
  <ref
guid="80c55b4e-d9db-4f38-96e5-e10e1b4f29e4"></ref>
  <ref
guid="62bc4092-16e5-4861-8105-16a5b61c4c7d"></ref>
  </connected_points>
  <connected_points
guid="6fa68bd5-7da0-4405-b2dd-15dac735c446"
last_change="2022-05-23T14:17:27.000" action="added" name="CP.17" interface="0">
    <point x="0.08" y="0.6" z="0"></point>
    <point x="0.602080289525547" y="0.6"
z="0"></point>
    <local_x x="1" y="0" z="0"></local_x>
    <local_y x="0" y="1" z="0"></local_y>
    <rigidity>
      <motions x_neg="6096" x_pos="6096"
y_neg="6096" y_pos="6096" z_neg="6096" z_pos="6096"></motions>
      <rotations x_neg="0" x_pos="0" y_neg="0"
y_pos="0" z_neg="0" z_pos="0"></rotations>
    </rigidity>
    <ref
guid="80c55b4e-d9db-4f38-96e5-e10e1b4f29e4"></ref>
    <ref
guid="62bc4092-16e5-4861-8105-16a5b61c4c7d"></ref>
    </connected_points>
```

```

        <connected_points
guid="87ecf123-abb2-4022-8c3a-5e3ac6b16499"
last_change="2022-05-23T14:17:27.000" action="added" name="CP.18" interface="0">
    <point x="0.13" y="0.6" z="0"></point>
    <point x="0.652080289525547" y="0.6"
z="0"></point>
        <local_x x="1" y="0" z="0"></local_x>
        <local_y x="0" y="1" z="0"></local_y>
        <rigidity>
            <motions x_neg="6096" x_pos="6096"
y_neg="6096" y_pos="6096" z_neg="6096" z_pos="6096"></motions>
            <rotations x_neg="0" x_pos="0" y_neg="0"
y_pos="0" z_neg="0" z_pos="0"></rotations>
        </rigidity>
        <ref
guid="80c55b4e-d9db-4f38-96e5-e10e1b4f29e4"></ref>
        <ref
guid="62bc4092-16e5-4861-8105-16a5b61c4c7d"></ref>
    </connected_points>
    <connected_points
guid="4f325886-0325-4085-ae6c-3a952400a7de"
last_change="2022-05-23T14:17:27.000" action="added" name="CP.19" interface="0">
    <point x="0.18" y="0.6" z="0"></point>
    <point x="0.702080289525547" y="0.6"
z="0"></point>
        <local_x x="1" y="0" z="0"></local_x>
        <local_y x="0" y="1" z="0"></local_y>
        <rigidity>
            <motions x_neg="6096" x_pos="6096"
y_neg="6096" y_pos="6096" z_neg="6096" z_pos="6096"></motions>
            <rotations x_neg="0" x_pos="0" y_neg="0"
y_pos="0" z_neg="0" z_pos="0"></rotations>
        </rigidity>
        <ref
guid="80c55b4e-d9db-4f38-96e5-e10e1b4f29e4"></ref>
        <ref
guid="62bc4092-16e5-4861-8105-16a5b61c4c7d"></ref>
    </connected_points>
    <connected_points
guid="8e5809ce-1fcf-4b1c-91ec-a25474398b66"
last_change="2022-05-23T14:17:27.000" action="added" name="CP.20" interface="0">
    <point x="0.23" y="0.6" z="0"></point>
    <point x="0.752080289525547" y="0.6"
z="0"></point>
        <local_x x="1" y="0" z="0"></local_x>
        <local_y x="0" y="1" z="0"></local_y>
        <rigidity>
            <motions x_neg="6096" x_pos="6096"
y_neg="6096" y_pos="6096" z_neg="6096" z_pos="6096"></motions>
            <rotations x_neg="0" x_pos="0" y_neg="0"
y_pos="0" z_neg="0" z_pos="0"></rotations>
        </rigidity>
        <ref
guid="80c55b4e-d9db-4f38-96e5-e10e1b4f29e4"></ref>

```

```

        <ref
guid="62bc4092-16e5-4861-8105-16a5b61c4c7d"></ref>
        </connected_points>
        <connected_points
guid="2149a435-974d-48d3-8e14-785758ae95bc"
last_change="2022-05-23T14:17:27.000" action="added" name="CP.21" interface="0">
        <point x="0.08" y="0.55" z="0"></point>
        <point x="0.602080289525547" y="0.55"
z="0"></point>
        <local_x x="1" y="0" z="0"></local_x>
        <local_y x="0" y="1" z="0"></local_y>
        <rigidity>
                <motions x_neg="6096" x_pos="6096"
y_neg="6096" y_pos="6096" z_neg="6096" z_pos="6096"></motions>
                <rotations x_neg="0" x_pos="0" y_neg="0"
y_pos="0" z_neg="0" z_pos="0"></rotations>
        </rigidity>
        <ref
guid="80c55b4e-d9db-4f38-96e5-e10e1b4f29e4"></ref>
        <ref
guid="62bc4092-16e5-4861-8105-16a5b61c4c7d"></ref>
        </connected_points>
        <connected_points
guid="a3c7b300-e51e-4545-8d36-5b1fd7f47219"
last_change="2022-05-23T14:17:27.000" action="added" name="CP.22" interface="0">
        <point x="0.13" y="0.55" z="0"></point>
        <point x="0.652080289525547" y="0.55"
z="0"></point>
        <local_x x="1" y="0" z="0"></local_x>
        <local_y x="0" y="1" z="0"></local_y>
        <rigidity>
                <motions x_neg="6096" x_pos="6096"
y_neg="6096" y_pos="6096" z_neg="6096" z_pos="6096"></motions>
                <rotations x_neg="0" x_pos="0" y_neg="0"
y_pos="0" z_neg="0" z_pos="0"></rotations>
        </rigidity>
        <ref
guid="80c55b4e-d9db-4f38-96e5-e10e1b4f29e4"></ref>
        <ref
guid="62bc4092-16e5-4861-8105-16a5b61c4c7d"></ref>
        </connected_points>
        <connected_points
guid="91f686ef-d30f-4c41-b349-183ff3cc2863"
last_change="2022-05-23T14:17:27.000" action="added" name="CP.23" interface="0">
        <point x="0.18" y="0.55" z="0"></point>
        <point x="0.702080289525547" y="0.55"
z="0"></point>
        <local_x x="1" y="0" z="0"></local_x>
        <local_y x="0" y="1" z="0"></local_y>
        <rigidity>
                <motions x_neg="6096" x_pos="6096"
y_neg="6096" y_pos="6096" z_neg="6096" z_pos="6096"></motions>
                <rotations x_neg="0" x_pos="0" y_neg="0"
y_pos="0" z_neg="0" z_pos="0"></rotations>

```



```

        </rigidity>
        <ref
guid="80c55b4e-d9db-4f38-96e5-e10e1b4f29e4"></ref>
        <ref
guid="62bc4092-16e5-4861-8105-16a5b61c4c7d"></ref>
        </connected_points>
        <connected_points
guid="941244e8-4e3a-4c33-a682-015d2b8a02cd"
last_change="2022-05-23T14:17:27.000" action="added" name="CP.24" interface="0">
        <point x="0.23" y="0.55" z="0"></point>
        <point x="0.752080289525547" y="0.55"
z="0"></point>
        <local_x x="1" y="0" z="0"></local_x>
        <local_y x="0" y="1" z="0"></local_y>
        <rigidity>
                <motions x_neg="6096" x_pos="6096"
y_neg="6096" y_pos="6096" z_neg="6096" z_pos="6096"></motions>
                <rotations x_neg="0" x_pos="0" y_neg="0"
y_pos="0" z_neg="0" z_pos="0"></rotations>
        </rigidity>
        <ref
guid="80c55b4e-d9db-4f38-96e5-e10e1b4f29e4"></ref>
        <ref
guid="62bc4092-16e5-4861-8105-16a5b61c4c7d"></ref>
        </connected_points>
        <connected_points
guid="2b65effb-ba1d-46aa-b2f4-b787e67071ac"
last_change="2022-05-23T14:17:27.000" action="added" name="CP.25" interface="0">
        <point x="0.08" y="0.5" z="0"></point>
        <point x="0.602080289525547" y="0.5"
z="0"></point>
        <local_x x="1" y="0" z="0"></local_x>
        <local_y x="0" y="1" z="0"></local_y>
        <rigidity>
                <motions x_neg="6096" x_pos="6096"
y_neg="6096" y_pos="6096" z_neg="6096" z_pos="6096"></motions>
                <rotations x_neg="0" x_pos="0" y_neg="0"
y_pos="0" z_neg="0" z_pos="0"></rotations>
        </rigidity>
        <ref
guid="80c55b4e-d9db-4f38-96e5-e10e1b4f29e4"></ref>
        <ref
guid="62bc4092-16e5-4861-8105-16a5b61c4c7d"></ref>
        </connected_points>
        <connected_points
guid="0629bc89-2200-4f0c-a3a2-8a5a183e2366"
last_change="2022-05-23T14:17:27.000" action="added" name="CP.26" interface="0">
        <point x="0.13" y="0.5" z="0"></point>
        <point x="0.652080289525547" y="0.5"
z="0"></point>
        <local_x x="1" y="0" z="0"></local_x>
        <local_y x="0" y="1" z="0"></local_y>
        <rigidity>
                <motions x_neg="6096" x_pos="6096"

```

```

y_neg="6096" y_pos="6096" z_neg="6096" z_pos="6096"></motions>
      <rotations x_neg="0" x_pos="0" y_neg="0"
y_pos="0" z_neg="0" z_pos="0"></rotations>
      </rigidity>
      <ref
guid="80c55b4e-d9db-4f38-96e5-e10e1b4f29e4"></ref>
      <ref
guid="62bc4092-16e5-4861-8105-16a5b61c4c7d"></ref>
      </connected_points>
      <connected_points
guid="2a8fbb25-c389-4770-96a9-69da1eac8612"
last_change="2022-05-23T14:17:27.000" action="added" name="CP.27" interface="0">
      <point x="0.18" y="0.5" z="0"></point>
      <point x="0.702080289525547" y="0.5"
z="0"></point>
      <local_x x="1" y="0" z="0"></local_x>
      <local_y x="0" y="1" z="0"></local_y>
      <rigidity>
      <motions x_neg="6096" x_pos="6096"
y_neg="6096" y_pos="6096" z_neg="6096" z_pos="6096"></motions>
      <rotations x_neg="0" x_pos="0" y_neg="0"
y_pos="0" z_neg="0" z_pos="0"></rotations>
      </rigidity>
      <ref
guid="80c55b4e-d9db-4f38-96e5-e10e1b4f29e4"></ref>
      <ref
guid="62bc4092-16e5-4861-8105-16a5b61c4c7d"></ref>
      </connected_points>
      <connected_points
guid="55577b88-0b53-4dbf-af7b-cfef19584ea"
last_change="2022-05-23T14:17:27.000" action="added" name="CP.28" interface="0">
      <point x="0.23" y="0.5" z="0"></point>
      <point x="0.752080289525547" y="0.5"
z="0"></point>
      <local_x x="1" y="0" z="0"></local_x>
      <local_y x="0" y="1" z="0"></local_y>
      <rigidity>
      <motions x_neg="6096" x_pos="6096"
y_neg="6096" y_pos="6096" z_neg="6096" z_pos="6096"></motions>
      <rotations x_neg="0" x_pos="0" y_neg="0"
y_pos="0" z_neg="0" z_pos="0"></rotations>
      </rigidity>
      <ref
guid="80c55b4e-d9db-4f38-96e5-e10e1b4f29e4"></ref>
      <ref
guid="62bc4092-16e5-4861-8105-16a5b61c4c7d"></ref>
      </connected_points>
      <connected_points
guid="77b0e050-4f86-4bc1-a675-87dea2c752ad"
last_change="2022-05-23T14:17:27.000" action="added" name="CP.29" interface="0">
      <point x="0.08" y="0.45" z="0"></point>
      <point x="0.602080289525547" y="0.45"
z="0"></point>
      <local_x x="1" y="0" z="0"></local_x>

```

```
        <local_y x="0" y="1" z="0"></local_y>
        <rigidity>
            <motions x_neg="6096" x_pos="6096"
y_neg="6096" y_pos="6096" z_neg="6096" z_pos="6096"></motions>
            <rotations x_neg="0" x_pos="0" y_neg="0"
y_pos="0" z_neg="0" z_pos="0"></rotations>
        </rigidity>
        <ref
guid="80c55b4e-d9db-4f38-96e5-e10e1b4f29e4"></ref>
        <ref
guid="62bc4092-16e5-4861-8105-16a5b61c4c7d"></ref>
        </connected_points>
        <connected_points
guid="a1b75a4d-7ca7-4278-89d6-bbf2a5b2c6a5"
last_change="2022-05-23T14:17:27.000" action="added" name="CP.30" interface="0">
            <point x="0.13" y="0.45" z="0"></point>
            <point x="0.652080289525547" y="0.45"
z="0"></point>
            <local_x x="1" y="0" z="0"></local_x>
            <local_y x="0" y="1" z="0"></local_y>
            <rigidity>
                <motions x_neg="6096" x_pos="6096"
y_neg="6096" y_pos="6096" z_neg="6096" z_pos="6096"></motions>
                <rotations x_neg="0" x_pos="0" y_neg="0"
y_pos="0" z_neg="0" z_pos="0"></rotations>
            </rigidity>
            <ref
guid="80c55b4e-d9db-4f38-96e5-e10e1b4f29e4"></ref>
            <ref
guid="62bc4092-16e5-4861-8105-16a5b61c4c7d"></ref>
            </connected_points>
            <connected_points
guid="91011edb-4f05-449c-8798-82337f04c8a4"
last_change="2022-05-23T14:17:27.000" action="added" name="CP.31" interface="0">
                <point x="0.18" y="0.45" z="0"></point>
                <point x="0.702080289525547" y="0.45"
z="0"></point>
                <local_x x="1" y="0" z="0"></local_x>
                <local_y x="0" y="1" z="0"></local_y>
                <rigidity>
                    <motions x_neg="6096" x_pos="6096"
y_neg="6096" y_pos="6096" z_neg="6096" z_pos="6096"></motions>
                    <rotations x_neg="0" x_pos="0" y_neg="0"
y_pos="0" z_neg="0" z_pos="0"></rotations>
                </rigidity>
                <ref
guid="80c55b4e-d9db-4f38-96e5-e10e1b4f29e4"></ref>
                <ref
guid="62bc4092-16e5-4861-8105-16a5b61c4c7d"></ref>
                </connected_points>
                <connected_points
guid="84ea9439-b930-44a8-9baa-902f80bc9456"
last_change="2022-05-23T14:17:27.000" action="added" name="CP.32" interface="0">
                    <point x="0.23" y="0.45" z="0"></point>
```

```
z="0"></point>
    <point x="0.752080289525547" y="0.45"
    <local_x x="1" y="0" z="0"></local_x>
    <local_y x="0" y="1" z="0"></local_y>
    <rigidity>
        <motions x_neg="6096" x_pos="6096"
y_neg="6096" y_pos="6096" z_neg="6096" z_pos="6096"></motions>
        <rotations x_neg="0" x_pos="0" y_neg="0"
y_pos="0" z_neg="0" z_pos="0"></rotations>
    </rigidity>
    <ref
guid="80c55b4e-d9db-4f38-96e5-e10e1b4f29e4"></ref>
    <ref
guid="62bc4092-16e5-4861-8105-16a5b61c4c7d"></ref>
    </connected_points>
    <connected_points
guid="66a60d33-cf7e-41d0-9660-260bf8a0e8db"
last_change="2022-05-23T14:17:27.000" action="added" name="CP.33" interface="0">
    <point x="0.08" y="0.4" z="0"></point>
    <point x="0.602080289525547" y="0.4"
z="0"></point>
    <local_x x="1" y="0" z="0"></local_x>
    <local_y x="0" y="1" z="0"></local_y>
    <rigidity>
        <motions x_neg="6096" x_pos="6096"
y_neg="6096" y_pos="6096" z_neg="6096" z_pos="6096"></motions>
        <rotations x_neg="0" x_pos="0" y_neg="0"
y_pos="0" z_neg="0" z_pos="0"></rotations>
    </rigidity>
    <ref
guid="80c55b4e-d9db-4f38-96e5-e10e1b4f29e4"></ref>
    <ref
guid="62bc4092-16e5-4861-8105-16a5b61c4c7d"></ref>
    </connected_points>
    <connected_points
guid="6fde07ae-b0da-422e-aa9c-1179ca3d5641"
last_change="2022-05-23T14:17:27.000" action="added" name="CP.34" interface="0">
    <point x="0.13" y="0.4" z="0"></point>
    <point x="0.652080289525547" y="0.4"
z="0"></point>
    <local_x x="1" y="0" z="0"></local_x>
    <local_y x="0" y="1" z="0"></local_y>
    <rigidity>
        <motions x_neg="6096" x_pos="6096"
y_neg="6096" y_pos="6096" z_neg="6096" z_pos="6096"></motions>
        <rotations x_neg="0" x_pos="0" y_neg="0"
y_pos="0" z_neg="0" z_pos="0"></rotations>
    </rigidity>
    <ref
guid="80c55b4e-d9db-4f38-96e5-e10e1b4f29e4"></ref>
    <ref
guid="62bc4092-16e5-4861-8105-16a5b61c4c7d"></ref>
    </connected_points>
    <connected_points
```

```

guid="f139a873-4ba0-412c-9add-6a217d0d2dc8"
last_change="2022-05-23T14:17:27.000" action="added" name="CP.35" interface="0">
  <point x="0.18" y="0.4" z="0"></point>
  <point x="0.702080289525547" y="0.4"
z="0"></point>
  <local_x x="1" y="0" z="0"></local_x>
  <local_y x="0" y="1" z="0"></local_y>
  <rigidity>
    <motions x_neg="6096" x_pos="6096"
y_neg="6096" y_pos="6096" z_neg="6096" z_pos="6096"></motions>
    <rotations x_neg="0" x_pos="0" y_neg="0"
y_pos="0" z_neg="0" z_pos="0"></rotations>
  </rigidity>
  <ref
guid="80c55b4e-d9db-4f38-96e5-e10e1b4f29e4"></ref>
  <ref
guid="62bc4092-16e5-4861-8105-16a5b61c4c7d"></ref>
  </connected_points>
  <connected_points
guid="d3d7b0cf-9506-445e-8e43-7a589f2e0a07"
last_change="2022-05-23T14:17:27.000" action="added" name="CP.36" interface="0">
  <point x="0.23" y="0.4" z="0"></point>
  <point x="0.752080289525547" y="0.4"
z="0"></point>
  <local_x x="1" y="0" z="0"></local_x>
  <local_y x="0" y="1" z="0"></local_y>
  <rigidity>
    <motions x_neg="6096" x_pos="6096"
y_neg="6096" y_pos="6096" z_neg="6096" z_pos="6096"></motions>
    <rotations x_neg="0" x_pos="0" y_neg="0"
y_pos="0" z_neg="0" z_pos="0"></rotations>
  </rigidity>
  <ref
guid="80c55b4e-d9db-4f38-96e5-e10e1b4f29e4"></ref>
  <ref
guid="62bc4092-16e5-4861-8105-16a5b61c4c7d"></ref>
  </connected_points>
  <connected_points
guid="3ba978ae-9fae-4863-af36-6f5a068d83e8"
last_change="2022-05-23T14:17:27.000" action="added" name="CP.37" interface="0">
  <point x="0.08" y="0.35" z="0"></point>
  <point x="0.602080289525547" y="0.35"
z="0"></point>
  <local_x x="1" y="0" z="0"></local_x>
  <local_y x="0" y="1" z="0"></local_y>
  <rigidity>
    <motions x_neg="6096" x_pos="6096"
y_neg="6096" y_pos="6096" z_neg="6096" z_pos="6096"></motions>
    <rotations x_neg="0" x_pos="0" y_neg="0"
y_pos="0" z_neg="0" z_pos="0"></rotations>
  </rigidity>
  <ref
guid="80c55b4e-d9db-4f38-96e5-e10e1b4f29e4"></ref>
  <ref

```

```

guid="62bc4092-16e5-4861-8105-16a5b61c4c7d"></ref>
  </connected_points>
  <connected_points
guid="836d592f-3584-4f8c-9655-07b9197ee2b0"
last_change="2022-05-23T14:17:27.000" action="added" name="CP.38" interface="0">
  <point x="0.13" y="0.35" z="0"></point>
  <point x="0.652080289525547" y="0.35"
z="0"></point>
  <local_x x="1" y="0" z="0"></local_x>
  <local_y x="0" y="1" z="0"></local_y>
  <rigidity>
    <motions x_neg="6096" x_pos="6096"
y_neg="6096" y_pos="6096" z_neg="6096" z_pos="6096"></motions>
    <rotations x_neg="0" x_pos="0" y_neg="0"
y_pos="0" z_neg="0" z_pos="0"></rotations>
  </rigidity>
  <ref
guid="80c55b4e-d9db-4f38-96e5-e10e1b4f29e4"></ref>
  <ref
guid="62bc4092-16e5-4861-8105-16a5b61c4c7d"></ref>
  </connected_points>
  <connected_points
guid="c3c48fde-734a-4784-a1e4-10389a533752"
last_change="2022-05-23T14:17:27.000" action="added" name="CP.39" interface="0">
  <point x="0.18" y="0.35" z="0"></point>
  <point x="0.702080289525547" y="0.35"
z="0"></point>
  <local_x x="1" y="0" z="0"></local_x>
  <local_y x="0" y="1" z="0"></local_y>
  <rigidity>
    <motions x_neg="6096" x_pos="6096"
y_neg="6096" y_pos="6096" z_neg="6096" z_pos="6096"></motions>
    <rotations x_neg="0" x_pos="0" y_neg="0"
y_pos="0" z_neg="0" z_pos="0"></rotations>
  </rigidity>
  <ref
guid="80c55b4e-d9db-4f38-96e5-e10e1b4f29e4"></ref>
  <ref
guid="62bc4092-16e5-4861-8105-16a5b61c4c7d"></ref>
  </connected_points>
  <connected_points
guid="4a8ccf15-b97f-4669-a773-7aae455cafec"
last_change="2022-05-23T14:17:27.000" action="added" name="CP.40" interface="0">
  <point x="0.23" y="0.35" z="0"></point>
  <point x="0.752080289525547" y="0.35"
z="0"></point>
  <local_x x="1" y="0" z="0"></local_x>
  <local_y x="0" y="1" z="0"></local_y>
  <rigidity>
    <motions x_neg="6096" x_pos="6096"
y_neg="6096" y_pos="6096" z_neg="6096" z_pos="6096"></motions>
    <rotations x_neg="0" x_pos="0" y_neg="0"
y_pos="0" z_neg="0" z_pos="0"></rotations>
  </rigidity>

```

```

                                <ref
guid="80c55b4e-d9db-4f38-96e5-e10e1b4f29e4"></ref>
                                <ref
guid="62bc4092-16e5-4861-8105-16a5b61c4c7d"></ref>
                                </connected_points>
                                <connected_points
guid="d24e10e0-4a90-4e6d-a9c0-3c8a53d7c0f6"
last_change="2022-05-23T14:17:27.000" action="added" name="CP.41" interface="0">
                                <point x="0.08" y="0.3" z="0"></point>
                                <point x="0.602080289525547" y="0.3"
z="0"></point>
                                <local_x x="1" y="0" z="0"></local_x>
                                <local_y x="0" y="1" z="0"></local_y>
                                <rigidity>
                                        <motions x_neg="6096" x_pos="6096"
y_neg="6096" y_pos="6096" z_neg="6096" z_pos="6096"></motions>
                                        <rotations x_neg="0" x_pos="0" y_neg="0"
y_pos="0" z_neg="0" z_pos="0"></rotations>
                                </rigidity>
                                <ref
guid="80c55b4e-d9db-4f38-96e5-e10e1b4f29e4"></ref>
                                <ref
guid="62bc4092-16e5-4861-8105-16a5b61c4c7d"></ref>
                                </connected_points>
                                <connected_points
guid="d82d0df5-f313-479d-a1b6-808edc5d8a47"
last_change="2022-05-23T14:17:27.000" action="added" name="CP.42" interface="0">
                                <point x="0.13" y="0.3" z="0"></point>
                                <point x="0.652080289525547" y="0.3"
z="0"></point>
                                <local_x x="1" y="0" z="0"></local_x>
                                <local_y x="0" y="1" z="0"></local_y>
                                <rigidity>
                                        <motions x_neg="6096" x_pos="6096"
y_neg="6096" y_pos="6096" z_neg="6096" z_pos="6096"></motions>
                                        <rotations x_neg="0" x_pos="0" y_neg="0"
y_pos="0" z_neg="0" z_pos="0"></rotations>
                                </rigidity>
                                <ref
guid="80c55b4e-d9db-4f38-96e5-e10e1b4f29e4"></ref>
                                <ref
guid="62bc4092-16e5-4861-8105-16a5b61c4c7d"></ref>
                                </connected_points>
                                <connected_points
guid="d4ab687e-4506-427f-86c0-4fca74b7fad5"
last_change="2022-05-23T14:17:27.000" action="added" name="CP.43" interface="0">
                                <point x="0.18" y="0.3" z="0"></point>
                                <point x="0.702080289525547" y="0.3"
z="0"></point>
                                <local_x x="1" y="0" z="0"></local_x>
                                <local_y x="0" y="1" z="0"></local_y>
                                <rigidity>
                                        <motions x_neg="6096" x_pos="6096"
y_neg="6096" y_pos="6096" z_neg="6096" z_pos="6096"></motions>

```

```

        <rotations x_neg="0" x_pos="0" y_neg="0"
y_pos="0" z_neg="0" z_pos="0"></rotations>
        </rigidity>
        <ref
guid="80c55b4e-d9db-4f38-96e5-e10e1b4f29e4"></ref>
        <ref
guid="62bc4092-16e5-4861-8105-16a5b61c4c7d"></ref>
        </connected_points>
        <connected_points
guid="867fb1d1-2a6e-4a11-8465-939cbec0c7d5"
last_change="2022-05-23T14:17:27.000" action="added" name="CP.44" interface="0">
        <point x="0.23" y="0.3" z="0"></point>
        <point x="0.752080289525547" y="0.3"
z="0"></point>
        <local_x x="1" y="0" z="0"></local_x>
        <local_y x="0" y="1" z="0"></local_y>
        <rigidity>
        <motions x_neg="6096" x_pos="6096"
y_neg="6096" y_pos="6096" z_neg="6096" z_pos="6096"></motions>
        <rotations x_neg="0" x_pos="0" y_neg="0"
y_pos="0" z_neg="0" z_pos="0"></rotations>
        </rigidity>
        <ref
guid="80c55b4e-d9db-4f38-96e5-e10e1b4f29e4"></ref>
        <ref
guid="62bc4092-16e5-4861-8105-16a5b61c4c7d"></ref>
        </connected_points>
        <connected_points
guid="a195ddcd-11d8-4f81-bb80-0a9205befa35"
last_change="2022-05-23T14:17:27.000" action="added" name="CP.45" interface="0">
        <point x="0.08" y="0.25" z="0"></point>
        <point x="0.602080289525547" y="0.25"
z="0"></point>
        <local_x x="1" y="0" z="0"></local_x>
        <local_y x="0" y="1" z="0"></local_y>
        <rigidity>
        <motions x_neg="6096" x_pos="6096"
y_neg="6096" y_pos="6096" z_neg="6096" z_pos="6096"></motions>
        <rotations x_neg="0" x_pos="0" y_neg="0"
y_pos="0" z_neg="0" z_pos="0"></rotations>
        </rigidity>
        <ref
guid="80c55b4e-d9db-4f38-96e5-e10e1b4f29e4"></ref>
        <ref
guid="62bc4092-16e5-4861-8105-16a5b61c4c7d"></ref>
        </connected_points>
        <connected_points
guid="f6515433-f245-4b32-b8ad-f07adcb95680"
last_change="2022-05-23T14:17:27.000" action="added" name="CP.46" interface="0">
        <point x="0.13" y="0.25" z="0"></point>
        <point x="0.652080289525547" y="0.25"
z="0"></point>
        <local_x x="1" y="0" z="0"></local_x>
        <local_y x="0" y="1" z="0"></local_y>

```



```
        <rigidity>
            <motions x_neg="6096" x_pos="6096"
y_neg="6096" y_pos="6096" z_neg="6096" z_pos="6096"></motions>
            <rotations x_neg="0" x_pos="0" y_neg="0"
y_pos="0" z_neg="0" z_pos="0"></rotations>
        </rigidity>
        <ref
guid="80c55b4e-d9db-4f38-96e5-e10e1b4f29e4"></ref>
        <ref
guid="62bc4092-16e5-4861-8105-16a5b61c4c7d"></ref>
        </connected_points>
        <connected_points
guid="4c41ab9e-fbbe-4f13-b8cd-5ec1a2c6d32d"
last_change="2022-05-23T14:17:27.000" action="added" name="CP.47" interface="0">
            <point x="0.18" y="0.25" z="0"></point>
            <point x="0.702080289525547" y="0.25"
z="0"></point>
            <local_x x="1" y="0" z="0"></local_x>
            <local_y x="0" y="1" z="0"></local_y>
        <rigidity>
            <motions x_neg="6096" x_pos="6096"
y_neg="6096" y_pos="6096" z_neg="6096" z_pos="6096"></motions>
            <rotations x_neg="0" x_pos="0" y_neg="0"
y_pos="0" z_neg="0" z_pos="0"></rotations>
        </rigidity>
        <ref
guid="80c55b4e-d9db-4f38-96e5-e10e1b4f29e4"></ref>
        <ref
guid="62bc4092-16e5-4861-8105-16a5b61c4c7d"></ref>
        </connected_points>
        <connected_points
guid="6b873eb2-279c-4b75-a8d0-7cff02f44bf9"
last_change="2022-05-23T14:17:27.000" action="added" name="CP.48" interface="0">
            <point x="0.23" y="0.25" z="0"></point>
            <point x="0.752080289525547" y="0.25"
z="0"></point>
            <local_x x="1" y="0" z="0"></local_x>
            <local_y x="0" y="1" z="0"></local_y>
        <rigidity>
            <motions x_neg="6096" x_pos="6096"
y_neg="6096" y_pos="6096" z_neg="6096" z_pos="6096"></motions>
            <rotations x_neg="0" x_pos="0" y_neg="0"
y_pos="0" z_neg="0" z_pos="0"></rotations>
        </rigidity>
        <ref
guid="80c55b4e-d9db-4f38-96e5-e10e1b4f29e4"></ref>
        <ref
guid="62bc4092-16e5-4861-8105-16a5b61c4c7d"></ref>
        </connected_points>
        <connected_points
guid="1a5cc6eb-4319-44b4-9cce-14571aedc097"
last_change="2022-05-23T14:17:27.000" action="added" name="CP.49" interface="0">
            <point x="0.08" y="0.2" z="0"></point>
            <point x="0.602080289525547" y="0.2"
```

```

z="0"></point>
    <local_x x="1" y="0" z="0"></local_x>
    <local_y x="0" y="1" z="0"></local_y>
    <rigidity>
        <motions x_neg="6096" x_pos="6096"
y_neg="6096" y_pos="6096" z_neg="6096" z_pos="6096"></motions>
        <rotations x_neg="0" x_pos="0" y_neg="0"
y_pos="0" z_neg="0" z_pos="0"></rotations>
    </rigidity>
    <ref
guid="80c55b4e-d9db-4f38-96e5-e10e1b4f29e4"></ref>
    <ref
guid="62bc4092-16e5-4861-8105-16a5b61c4c7d"></ref>
    </connected_points>
    <connected_points
guid="4ad9dde7-384b-4b92-b409-a5d4ed5d90ba"
last_change="2022-05-23T14:17:27.000" action="added" name="CP.50" interface="0">
    <point x="0.13" y="0.2" z="0"></point>
    <point x="0.652080289525547" y="0.2"
z="0"></point>
    <local_x x="1" y="0" z="0"></local_x>
    <local_y x="0" y="1" z="0"></local_y>
    <rigidity>
        <motions x_neg="6096" x_pos="6096"
y_neg="6096" y_pos="6096" z_neg="6096" z_pos="6096"></motions>
        <rotations x_neg="0" x_pos="0" y_neg="0"
y_pos="0" z_neg="0" z_pos="0"></rotations>
    </rigidity>
    <ref
guid="80c55b4e-d9db-4f38-96e5-e10e1b4f29e4"></ref>
    <ref
guid="62bc4092-16e5-4861-8105-16a5b61c4c7d"></ref>
    </connected_points>
    <connected_points
guid="6ad4391b-ee57-448f-a35e-8eb16141d7f2"
last_change="2022-05-23T14:17:27.000" action="added" name="CP.51" interface="0">
    <point x="0.18" y="0.2" z="0"></point>
    <point x="0.702080289525547" y="0.2"
z="0"></point>
    <local_x x="1" y="0" z="0"></local_x>
    <local_y x="0" y="1" z="0"></local_y>
    <rigidity>
        <motions x_neg="6096" x_pos="6096"
y_neg="6096" y_pos="6096" z_neg="6096" z_pos="6096"></motions>
        <rotations x_neg="0" x_pos="0" y_neg="0"
y_pos="0" z_neg="0" z_pos="0"></rotations>
    </rigidity>
    <ref
guid="80c55b4e-d9db-4f38-96e5-e10e1b4f29e4"></ref>
    <ref
guid="62bc4092-16e5-4861-8105-16a5b61c4c7d"></ref>
    </connected_points>
    <connected_points
guid="8210fff5-d9c6-4c70-8708-ae7529e2684e"

```

```
last_change="2022-05-23T14:17:27.000" action="added" name="CP.52" interface="0">
  <point x="0.23" y="0.2" z="0"></point>
  <point x="0.752080289525547" y="0.2"
z="0"></point>
  <local_x x="1" y="0" z="0"></local_x>
  <local_y x="0" y="1" z="0"></local_y>
  <rigidity>
    <motions x_neg="6096" x_pos="6096"
y_neg="6096" y_pos="6096" z_neg="6096" z_pos="6096"></motions>
    <rotations x_neg="0" x_pos="0" y_neg="0"
y_pos="0" z_neg="0" z_pos="0"></rotations>
  </rigidity>
  <ref
guid="80c55b4e-d9db-4f38-96e5-e10e1b4f29e4"></ref>
  <ref
guid="62bc4092-16e5-4861-8105-16a5b61c4c7d"></ref>
</connected_points>
<connected_points
guid="e8e73af3-76f1-4b74-9974-4bdf8a958969"
last_change="2022-05-23T14:17:27.000" action="added" name="CP.53" interface="0">
  <point x="0.08" y="0.15" z="0"></point>
  <point x="0.602080289525547" y="0.15"
z="0"></point>
  <local_x x="1" y="0" z="0"></local_x>
  <local_y x="0" y="1" z="0"></local_y>
  <rigidity>
    <motions x_neg="6096" x_pos="6096"
y_neg="6096" y_pos="6096" z_neg="6096" z_pos="6096"></motions>
    <rotations x_neg="0" x_pos="0" y_neg="0"
y_pos="0" z_neg="0" z_pos="0"></rotations>
  </rigidity>
  <ref
guid="80c55b4e-d9db-4f38-96e5-e10e1b4f29e4"></ref>
  <ref
guid="62bc4092-16e5-4861-8105-16a5b61c4c7d"></ref>
</connected_points>
<connected_points
guid="6d6f7e18-0e2f-4739-818c-9fa38bfd5093"
last_change="2022-05-23T14:17:27.000" action="added" name="CP.54" interface="0">
  <point x="0.13" y="0.15" z="0"></point>
  <point x="0.652080289525547" y="0.15"
z="0"></point>
  <local_x x="1" y="0" z="0"></local_x>
  <local_y x="0" y="1" z="0"></local_y>
  <rigidity>
    <motions x_neg="6096" x_pos="6096"
y_neg="6096" y_pos="6096" z_neg="6096" z_pos="6096"></motions>
    <rotations x_neg="0" x_pos="0" y_neg="0"
y_pos="0" z_neg="0" z_pos="0"></rotations>
  </rigidity>
  <ref
guid="80c55b4e-d9db-4f38-96e5-e10e1b4f29e4"></ref>
  <ref
guid="62bc4092-16e5-4861-8105-16a5b61c4c7d"></ref>
```

```
        </connected_points>
        <connected_points
guid="6687ae6e-91a0-4375-a0b1-05a2d1016e22"
last_change="2022-05-23T14:17:27.000" action="added" name="CP.55" interface="0">
    <point x="0.18" y="0.15" z="0"></point>
    <point x="0.702080289525547" y="0.15"
z="0"></point>
    <local_x x="1" y="0" z="0"></local_x>
    <local_y x="0" y="1" z="0"></local_y>
    <rigidity>
        <motions x_neg="6096" x_pos="6096"
y_neg="6096" y_pos="6096" z_neg="6096" z_pos="6096"></motions>
        <rotations x_neg="0" x_pos="0" y_neg="0"
y_pos="0" z_neg="0" z_pos="0"></rotations>
    </rigidity>
    <ref
guid="80c55b4e-d9db-4f38-96e5-e10e1b4f29e4"></ref>
    <ref
guid="62bc4092-16e5-4861-8105-16a5b61c4c7d"></ref>
    </connected_points>
    <connected_points
guid="c5f62d8c-0cfe-45e1-81af-078081f3e79a"
last_change="2022-05-23T14:17:27.000" action="added" name="CP.56" interface="0">
    <point x="0.23" y="0.15" z="0"></point>
    <point x="0.752080289525547" y="0.15"
z="0"></point>
    <local_x x="1" y="0" z="0"></local_x>
    <local_y x="0" y="1" z="0"></local_y>
    <rigidity>
        <motions x_neg="6096" x_pos="6096"
y_neg="6096" y_pos="6096" z_neg="6096" z_pos="6096"></motions>
        <rotations x_neg="0" x_pos="0" y_neg="0"
y_pos="0" z_neg="0" z_pos="0"></rotations>
    </rigidity>
    <ref
guid="80c55b4e-d9db-4f38-96e5-e10e1b4f29e4"></ref>
    <ref
guid="62bc4092-16e5-4861-8105-16a5b61c4c7d"></ref>
    </connected_points>
    <connected_points
guid="35443f63-b388-41e9-8ea1-f6535ee735bb"
last_change="2022-05-23T14:17:27.000" action="added" name="CP.57" interface="0">
    <point x="0.08" y="0.1" z="0"></point>
    <point x="0.602080289525547" y="0.1"
z="0"></point>
    <local_x x="1" y="0" z="0"></local_x>
    <local_y x="0" y="1" z="0"></local_y>
    <rigidity>
        <motions x_neg="6096" x_pos="6096"
y_neg="6096" y_pos="6096" z_neg="6096" z_pos="6096"></motions>
        <rotations x_neg="0" x_pos="0" y_neg="0"
y_pos="0" z_neg="0" z_pos="0"></rotations>
    </rigidity>
    <ref
```

```

guid="80c55b4e-d9db-4f38-96e5-e10e1b4f29e4"></ref>
  <ref
guid="62bc4092-16e5-4861-8105-16a5b61c4c7d"></ref>
  </connected_points>
  <connected_points
guid="e4708370-1cda-4241-81fa-7e9829daabbc"
last_change="2022-05-23T14:17:27.000" action="added" name="CP.58" interface="0">
  <point x="0.13" y="0.1" z="0"></point>
  <point x="0.652080289525547" y="0.1"
z="0"></point>
  <local_x x="1" y="0" z="0"></local_x>
  <local_y x="0" y="1" z="0"></local_y>
  <rigidity>
    <motions x_neg="6096" x_pos="6096"
y_neg="6096" y_pos="6096" z_neg="6096" z_pos="6096"></motions>
    <rotations x_neg="0" x_pos="0" y_neg="0"
y_pos="0" z_neg="0" z_pos="0"></rotations>
  </rigidity>
  <ref
guid="80c55b4e-d9db-4f38-96e5-e10e1b4f29e4"></ref>
  <ref
guid="62bc4092-16e5-4861-8105-16a5b61c4c7d"></ref>
  </connected_points>
  <connected_points
guid="d09e7a9c-b3ea-46ba-aa7b-d5817bbef062"
last_change="2022-05-23T14:17:27.000" action="added" name="CP.59" interface="0">
  <point x="0.18" y="0.1" z="0"></point>
  <point x="0.702080289525547" y="0.1"
z="0"></point>
  <local_x x="1" y="0" z="0"></local_x>
  <local_y x="0" y="1" z="0"></local_y>
  <rigidity>
    <motions x_neg="6096" x_pos="6096"
y_neg="6096" y_pos="6096" z_neg="6096" z_pos="6096"></motions>
    <rotations x_neg="0" x_pos="0" y_neg="0"
y_pos="0" z_neg="0" z_pos="0"></rotations>
  </rigidity>
  <ref
guid="80c55b4e-d9db-4f38-96e5-e10e1b4f29e4"></ref>
  <ref
guid="62bc4092-16e5-4861-8105-16a5b61c4c7d"></ref>
  </connected_points>
  <connected_points
guid="4f9fadd7-275f-44ab-a614-921a35343ed8"
last_change="2022-05-23T14:17:27.000" action="added" name="CP.60" interface="0">
  <point x="0.23" y="0.1" z="0"></point>
  <point x="0.752080289525547" y="0.1"
z="0"></point>
  <local_x x="1" y="0" z="0"></local_x>
  <local_y x="0" y="1" z="0"></local_y>
  <rigidity>
    <motions x_neg="6096" x_pos="6096"
y_neg="6096" y_pos="6096" z_neg="6096" z_pos="6096"></motions>
    <rotations x_neg="0" x_pos="0" y_neg="0"

```

```

y_pos="0" z_neg="0" z_pos="0"></rotations>
      </rigidity>
      <ref
guid="80c55b4e-d9db-4f38-96e5-e10e1b4f29e4"></ref>
      <ref
guid="62bc4092-16e5-4861-8105-16a5b61c4c7d"></ref>
      </connected_points>
      <connected_points
guid="5e8ca42d-7944-4298-9960-57ed28606e92"
last_change="2022-05-23T14:17:27.000" action="added" name="CP.61" interface="0">
      <point x="0.08" y="0.05" z="0"></point>
      <point x="0.602080289525547" y="0.05"
z="0"></point>
      <local_x x="1" y="0" z="0"></local_x>
      <local_y x="0" y="1" z="0"></local_y>
      <rigidity>
      <motions x_neg="6096" x_pos="6096"
y_neg="6096" y_pos="6096" z_neg="6096" z_pos="6096"></motions>
      <rotations x_neg="0" x_pos="0" y_neg="0"
y_pos="0" z_neg="0" z_pos="0"></rotations>
      </rigidity>
      <ref
guid="80c55b4e-d9db-4f38-96e5-e10e1b4f29e4"></ref>
      <ref
guid="62bc4092-16e5-4861-8105-16a5b61c4c7d"></ref>
      </connected_points>
      <connected_points
guid="07516d30-9018-4fce-8631-d31153e9b7fa"
last_change="2022-05-23T14:17:27.000" action="added" name="CP.62" interface="0">
      <point x="0.13" y="0.05" z="0"></point>
      <point x="0.652080289525547" y="0.05"
z="0"></point>
      <local_x x="1" y="0" z="0"></local_x>
      <local_y x="0" y="1" z="0"></local_y>
      <rigidity>
      <motions x_neg="6096" x_pos="6096"
y_neg="6096" y_pos="6096" z_neg="6096" z_pos="6096"></motions>
      <rotations x_neg="0" x_pos="0" y_neg="0"
y_pos="0" z_neg="0" z_pos="0"></rotations>
      </rigidity>
      <ref
guid="80c55b4e-d9db-4f38-96e5-e10e1b4f29e4"></ref>
      <ref
guid="62bc4092-16e5-4861-8105-16a5b61c4c7d"></ref>
      </connected_points>
      <connected_points
guid="d6cca1dd-0a1a-496d-98c5-735ce966d5e0"
last_change="2022-05-23T14:17:27.000" action="added" name="CP.63" interface="0">
      <point x="0.18" y="0.05" z="0"></point>
      <point x="0.702080289525547" y="0.05"
z="0"></point>
      <local_x x="1" y="0" z="0"></local_x>
      <local_y x="0" y="1" z="0"></local_y>
      <rigidity>

```

```

        <motions x_neg="6096" x_pos="6096"
y_neg="6096" y_pos="6096" z_neg="6096" z_pos="6096"></motions>
        <rotations x_neg="0" x_pos="0" y_neg="0"
y_pos="0" z_neg="0" z_pos="0"></rotations>
    </rigidity>
    <ref
guid="80c55b4e-d9db-4f38-96e5-e10e1b4f29e4"></ref>
    <ref
guid="62bc4092-16e5-4861-8105-16a5b61c4c7d"></ref>
    </connected_points>
    <connected_points
guid="3f0fdcac-9bd0-49ec-9c43-6af7e08dcf46"
last_change="2022-05-23T14:17:27.000" action="added" name="CP.64" interface="0">
    <point x="0.23" y="0.05" z="0"></point>
    <point x="0.752080289525547" y="0.05"
z="0"></point>
    <local_x x="1" y="0" z="0"></local_x>
    <local_y x="0" y="1" z="0"></local_y>
    <rigidity>
        <motions x_neg="6096" x_pos="6096"
y_neg="6096" y_pos="6096" z_neg="6096" z_pos="6096"></motions>
        <rotations x_neg="0" x_pos="0" y_neg="0"
y_pos="0" z_neg="0" z_pos="0"></rotations>
    </rigidity>
    <ref
guid="80c55b4e-d9db-4f38-96e5-e10e1b4f29e4"></ref>
    <ref
guid="62bc4092-16e5-4861-8105-16a5b61c4c7d"></ref>
    </connected_points>
</advanced-fem>
</entities>
<materials>
    <material guid="99915fcb-e324-4e94-90bb-082b32a698f0"
last_change="2021-01-07T14:54:44.000" action="added" standard="EC" country="S"
name="GL 30h">
        <timber mass="0.48" E_0="13600000" E_1="300000"
E_2="300000" nu_0="0" nu_1="0" nu_2="0" alfa_0="0" alfa_1="0" alfa_2="0"
G_0="650000" G_1="650000" G_2="650000" type="1" quality="0" Fmk0="30" Fmk90="30"
Ft0k="24" Ft90k="0.5" Fc0k="30" Fc90k="2.5" Fvk="3.5" E0mean="13600"
E90mean="300" E0comp="13700" E90comp="460" Gmean="650" E005="11300" G005="540"
Rhok="430" Rhomean="480" gammaM_0="1.3" gammaM_1="1" ksys="1" k_cr="0.67"
service_class="2" kdefU="0" kdefSq="2" kdefSf="2" kdefSc="2"
gammaMfi="1"></timber>
    </material>
    <material guid="60f80ee8-264c-4963-8bc2-2895cdd41db9"
last_change="2022-04-20T05:43:35.000" action="added" standard="EC" country="S"
name="S 460">
        <steel mass="7.85" E_0="210000000" E_1="210000000"
E_2="210000000" nu_0="0.3" nu_1="0.3" nu_2="0.3" alfa_0="0.000012"
alfa_1="0.000012" alfa_2="0.000012" G_0="80769230.7692308"
G_1="80769230.7692308" G_2="80769230.7692308" Fyk16="460" Fyk40="460"
Fyk63="430" Fyk80="430" Fyk100="430" Fyk150="430" Fyk200="430" Fyk250="430"
Fyk400="430" Fuk3="540" Fuk40="540" Fuk100="540" Fuk150="540" Fuk250="540"
Fuk400="540" gammaM0_0="1" gammaM0_1="1" gammaM1_0="1" gammaM1_1="1"

```

```

gammaM2_0="1.2" gammaM2_1="1" gammaM5_0="1" gammaM5_1="1" Ek="210000"
Ed_0="210000" Ed_1="210000" nu="0.3" G="80769" alfa="0.000012"></steel>
  </material>
</materials>
<geometry>
  <curve type="line">
    <point x="0" y="0.05" z="0"></point>
    <point x="0.31" y="0.05" z="0"></point>
    <normal x="0" y="1" z="0"></normal>
    <style layer="0"></style>
  </curve>
  <curve type="line">
    <point x="0" y="0.1" z="0"></point>
    <point x="0.31" y="0.1" z="0"></point>
    <normal x="0" y="1" z="0"></normal>
    <style layer="0"></style>
  </curve>
  <curve type="line">
    <point x="0" y="0.15" z="0"></point>
    <point x="0.31" y="0.15" z="0"></point>
    <normal x="0" y="1" z="0"></normal>
    <style layer="0"></style>
  </curve>
  <curve type="line">
    <point x="0" y="0.2" z="0"></point>
    <point x="0.31" y="0.2" z="0"></point>
    <normal x="0" y="1" z="0"></normal>
    <style layer="0"></style>
  </curve>
  <curve type="line">
    <point x="0" y="0.25" z="0"></point>
    <point x="0.31" y="0.25" z="0"></point>
    <normal x="0" y="1" z="0"></normal>
    <style layer="0"></style>
  </curve>
  <curve type="line">
    <point x="0" y="0.3" z="0"></point>
    <point x="0.31" y="0.3" z="0"></point>
    <normal x="0" y="1" z="0"></normal>
    <style layer="0"></style>
  </curve>
  <curve type="line">
    <point x="0" y="0.35" z="0"></point>
    <point x="0.31" y="0.35" z="0"></point>
    <normal x="0" y="1" z="0"></normal>
    <style layer="0"></style>
  </curve>
  <curve type="line">
    <point x="0" y="0.4" z="0"></point>
    <point x="0.31" y="0.4" z="0"></point>
    <normal x="0" y="1" z="0"></normal>
    <style layer="0"></style>
  </curve>
  <curve type="line">

```



```

    <point x="0" y="0.45" z="0"></point>
    <point x="0.31" y="0.45" z="0"></point>
    <normal x="0" y="1" z="0"></normal>
    <style layer="0"></style>
</curve>
<curve type="line">
    <point x="0" y="0.5" z="0"></point>
    <point x="0.31" y="0.5" z="0"></point>
    <normal x="0" y="1" z="0"></normal>
    <style layer="0"></style>
</curve>
<curve type="line">
    <point x="0" y="0.55" z="0"></point>
    <point x="0.31" y="0.55" z="0"></point>
    <normal x="0" y="1" z="0"></normal>
    <style layer="0"></style>
</curve>
<curve type="line">
    <point x="0" y="0.6" z="0"></point>
    <point x="0.31" y="0.6" z="0"></point>
    <normal x="0" y="1" z="0"></normal>
    <style layer="0"></style>
</curve>
<curve type="line">
    <point x="0" y="0.65" z="0"></point>
    <point x="0.31" y="0.65" z="0"></point>
    <normal x="0" y="1" z="0"></normal>
    <style layer="0"></style>
</curve>
<curve type="line">
    <point x="0" y="0.7" z="0"></point>
    <point x="0.31" y="0.7" z="0"></point>
    <normal x="0" y="1" z="0"></normal>
    <style layer="0"></style>
</curve>
<curve type="line">
    <point x="0" y="0.75" z="0"></point>
    <point x="0.31" y="0.75" z="0"></point>
    <normal x="0" y="1" z="0"></normal>
    <style layer="0"></style>
</curve>
<curve type="line">
    <point x="0" y="0.8" z="0"></point>
    <point x="0.31" y="0.8" z="0"></point>
    <normal x="0" y="1" z="0"></normal>
    <style layer="0"></style>
</curve>
<curve type="line">
    <point x="0.08" y="0" z="0"></point>
    <point x="0.08" y="0.85" z="0"></point>
    <normal x="-1" y="0" z="0"></normal>
    <style layer="0"></style>
</curve>
<curve type="line">

```

```

        <point x="0.13" y="0" z="0"></point>
        <point x="0.13" y="0.85" z="0"></point>
        <normal x="-1" y="0" z="0"></normal>
        <style layer="0"></style>
    </curve>
    <curve type="line">
        <point x="0.18" y="0" z="0"></point>
        <point x="0.18" y="0.85" z="0"></point>
        <normal x="-1" y="0" z="0"></normal>
        <style layer="0"></style>
    </curve>
    <curve type="line">
        <point x="0.23" y="0" z="0"></point>
        <point x="0.23" y="0.85" z="0"></point>
        <normal x="-1" y="0" z="0"></normal>
        <style layer="0"></style>
    </curve>
    <curve type="line">
        <point x="0.522080289525547" y="0.05" z="0"></point>
        <point x="0.832080289525547" y="0.05" z="0"></point>
        <normal x="0" y="1" z="0"></normal>
        <style layer="0"></style>
    </curve>
    <curve type="line">
        <point x="0.522080289525547" y="0.1" z="0"></point>
        <point x="0.832080289525547" y="0.1" z="0"></point>
        <normal x="0" y="1" z="0"></normal>
        <style layer="0"></style>
    </curve>
    <curve type="line">
        <point x="0.522080289525547" y="0.15" z="0"></point>
        <point x="0.832080289525547" y="0.15" z="0"></point>
        <normal x="0" y="1" z="0"></normal>
        <style layer="0"></style>
    </curve>
    <curve type="line">
        <point x="0.522080289525547" y="0.2" z="0"></point>
        <point x="0.832080289525547" y="0.2" z="0"></point>
        <normal x="0" y="1" z="0"></normal>
        <style layer="0"></style>
    </curve>
    <curve type="line">
        <point x="0.522080289525547" y="0.25" z="0"></point>
        <point x="0.832080289525547" y="0.25" z="0"></point>
        <normal x="0" y="1" z="0"></normal>
        <style layer="0"></style>
    </curve>
    <curve type="line">
        <point x="0.522080289525547" y="0.3" z="0"></point>
        <point x="0.832080289525547" y="0.3" z="0"></point>
        <normal x="0" y="1" z="0"></normal>
        <style layer="0"></style>
    </curve>
    <curve type="line">

```



```

        <point x="0.522080289525547" y="0.8" z="0"></point>
        <point x="0.832080289525547" y="0.8" z="0"></point>
        <normal x="0" y="1" z="0"></normal>
        <style layer="0"></style>
    </curve>
    <curve type="line">
        <point x="0.602080289525547" y="0" z="0"></point>
        <point x="0.602080289525547" y="0.85" z="0"></point>
        <normal x="-1" y="0" z="0"></normal>
        <style layer="0"></style>
    </curve>
    <curve type="line">
        <point x="0.652080289525547" y="0" z="0"></point>
        <point x="0.652080289525547" y="0.85" z="0"></point>
        <normal x="-1" y="0" z="0"></normal>
        <style layer="0"></style>
    </curve>
    <curve type="line">
        <point x="0.702080289525547" y="0" z="0"></point>
        <point x="0.702080289525547" y="0.85" z="0"></point>
        <normal x="-1" y="0" z="0"></normal>
        <style layer="0"></style>
    </curve>
    <curve type="line">
        <point x="0.752080289525547" y="0" z="0"></point>
        <point x="0.752080289525547" y="0.85" z="0"></point>
        <normal x="-1" y="0" z="0"></normal>
        <style layer="0"></style>
    </curve>
    <line_type name="CONTINUOUS"></line_type>
    <layer name="0" colour="000000" hidden="false"
protected="false"></layer>
</geometry>
<end></end>
</database>

```

DEPARTMENT OF ARCHITECTURE AND CIVIL ENGINEERING
CHALMERS UNIVERSITY OF TECHNOLOGY
Gothenburg, Sweden
www.chalmers.se



CHALMERS
UNIVERSITY OF TECHNOLOGY