

CHALMERS



LOW ORDER APPROXIMATIONS OF CONTINUOUSLY STIRRED BIOFILM REACTORS WITH MONOD KINETICS

ELIN GÖRANSSON

Control and Automation Laboratory

Department of Signals and Systems

CHALMERS UNIVERSITY OF TECHNOLOGY

Göteborg, Sweden

EX001/2004

Abstract

Design of controllers and optimization of plants using biofilm reactors often require dynamic models and efficient methods of simulation. Continuously stirred biofilm reactors (CSBRs) are useful model units in modeling of a variety of different biofilm reactors. Often the reaction kinetics in the biofilm is described by a Monod expression. Using standard modeling assumptions the equations describing the fast dynamics of a CSBR will then, for each substrate, be one nonlinear partial differential equation coupled with one linear ordinary differential equation. Here it is shown how a few nonlinear ordinary differential equations, which may be solved with standard integration methods, can be used as a close approximation.

The approximations are derived using two common MWR methods, the Galerkin method and the orthogonal collocation method. Uniqueness and convergence properties are discussed. The stationary approximations can either be used as they are or to generate initial values for iterative methods to find solutions to more complicated models used, for example, in studies of the long term dynamics.

Simulations of steps, impulses and random input responses using the approximations are compared to high accuracy simulations using the finite element method. The simulations show that a second order state space model is enough to describe the system for biofilms and reactors with low reaction rates and where the bulk volume is large compared to the liquid volume in the biofilm. A sixth order approximation, with a maximum error of 0.5%, should however be sufficient in almost all applications. The orthogonal collocation method turns out to have some advantages compared to the Galerkin method. It is easy to expand to higher orders, the errors are somewhat smaller, and the model expressions are simpler. Further, it is investigated how a liquid boundary layer on the biofilm surface affects the accuracy of the approximations. Simulations imply that the errors, compared to the FEM simulations, are smaller when this boundary layer is considered in the model. Finally, a collocation method where the collocation points are not chosen to be roots of orthogonal polynomials is shown to be less accurate than the standard orthogonal collocation method, where the collocation points are the roots of Legendre polynomials.

Sammanfattning

Regulatordesign och optimering av anläggningar med biofilmreaktorer kräver ofta dynamiska modeller och effektiva simuleringsmetoder. En kontinuerligt omrörd biofilmreaktor (CSBR) är en användbar modellenhet vid modellering av många olika typer av biofilmsreaktorer. Reaktionskinetiken i biofilmen beskrivs ofta av ett Monoduttryck. Om man använder standardantaganden i modelleringen kommer ekvationerna som beskriver den snabba dynamiken hos en CSBR vara en olinjär partiell differentialekvation kopplad med en linjär ordinär differentialekvation. I den här rapporten visas det hur ett fåtal olinjära ordinära differentialekvationer, som kan lösas med vanliga integrationsmetoder, kan användas som en bra approximation.

Approximationerna tas fram med hjälp av två vanliga viktade residual-metoder (MWR): Galerkin och ortogonal kollokation. Entydighet och konvergens diskuteras i ett kapitel. De stationära lösningarna kan antingen användas som de är eller för att generera startvärden till iterativa metoder för att hitta lösningar till mer komplicerade modeller, som t.ex. beskriver den långsamma dynamiken.

Steg- och impulssvar samt svar på stokastiska insignaler har simulerats för approximationerna och jämförts med simuleringar där finita elementmetoden använts. Simuleringarna visar att en andra ordningens tillståndsmodell är tillräcklig för att beskriva systemet för biofilmer och reaktorer med låga reaktionshastigheter och där bulkvolymen är stor jämfört med volymen av vätskan i biofilmen. En sjätte ordningens approximation däremot, med ett maximalt fel på 0.5%, bör vara tillräcklig i nästan alla tillämpningar. Ortogonal kollokation visar sig ha en del fördelar jämfört med Galerkinmetoden. Den är lätt att utvidga till högre ordning, felet är något mindre och uttrycken i modellen är enklare. Vidare undersöks det hur en vätskefilm utanpå biofilmen påverkar approximationernas noggrannhet. Simuleringar antyder att felet, jämfört med finita elementlösningen, är mindre när den här vätskefilmen tas med i modellen. Slutligen visas att en kollokationsmetod där kollokationspunkterna inte väljs som rötter till ortogonala polynom ger större fel än den ortogonala kollokationen där kollokationspunkterna är rötter till legendrepolynom.

Contents

1	INTRODUCTION	1
2	NOTATION	4
3	MODELING	7
4	MODEL APPROXIMATION	9
4.1	The Galerkin Method	9
4.1.1	Steady State Model	11
4.2	The Orthogonal Collocation Method	12
4.2.1	Steady State Model	14
4.3	The Subdomain Method	15
4.4	Diffusion Layer on the Biofilm Surface	16
5	MODEL PROPERTIES	18
5.1	Uniqueness	18
5.1.1	The Galerkin Method	19
5.1.2	The Orthogonal Collocation Method	19
5.2	Convergence	20

5.2.1	The Orthogonal Collocation Method	20
6	SIMULATION	22
6.1	Parameter Choices	22
6.2	Error Estimation	23
6.3	FEM Simulation	23
6.4	Steady State Models	24
6.5	Dynamic Models	28
6.5.1	Step Response	28
6.5.2	Impulse Response	34
6.5.3	Random Influent Concentration	38
6.5.4	Non-orthogonal Collocation	43
6.5.5	Diffusion Layer on the Biofilm Surface	44
7	CONCLUSION	46
	APPENDIX	51
A	Parameters	51
B	Pseudoanalytical solution by Sáez and Rittmann	54
C	Tables of Approximation Errors	56
D	Figures	80

Chapter 1

INTRODUCTION

A biofilm can be characterized as an organic matrix consisting of a complex community of bacteria, algae, fungi and protozoa embedded in organic polymers. In fixed biofilm reactors the biofilm is attached to substrata that, generally, are impermeable. Substrates diffuse from the bulk liquid into the biofilm where the bacteria carry out the desired transformations of the substrates. Depending on what kind of biofilm reactor, the biofilm substrata may be suspended carrier material or fixed packing media that can be either structured or random. Typical examples of fixed biofilm reactors are: biological fluidized beds, biofilters of different kinds, moving bed reactors, rotating biological contactors, and trickling filters. Reactors of this kind have attained increased attention, particularly in drinking water and wastewater treatment due to the ability to withhold bacterial populations having low growth rates, and new materials that give high specific capacities. [Rittmann and McCarty (1980); Wik (1999a)]

The dynamics of biofilm reactors can be divided into slow modes and fast modes. The fast dynamics are mainly caused by the reactor hydraulics and diffusive mass transfer in the biofilm, while the slow dynamics are caused by the growth and decay of the organisms in the biofilm. These dynamic modes are generally separated by several orders of magnitude since it, generally, takes days for the fauna to change while the fast transients settle in less than an hour. Thus, the slow transients can often be ignored when only the fast dynamics are studied (Kissel *et al.* 1984).

Most of the reported dynamic modeling and work on biofilm reactors have been focused on the slow biofilm dynamics, which have effects on the operation of the plants over longer periods of time [Andersson *et al.* (1994); Boller *et al.* (1997)]. However, there are several reasons to investigate, to model and to analyze the fast dynamics also. First of all, in the daily operation of a plant using biofilm reactors the fast dynamics often have to be taken into consideration to optimize the operation, and to guarantee stable control systems. The fast dynamics also play an important role for the reactor efficiency when the substrate load varies quickly (Rittmann

1985). Further, since physically based models of the fast dynamics are in many ways simplifications of more complex models of the slow dynamics, important model parameters are the same [Kissel *et al.* (1984); Gujer and Wanner (1990); Wik and Breitholtz (1996)]. Hence, parameter identification from experimental data, using models of the fast dynamics, can be a way of acquiring information about the slow dynamics as well.

A continuously stirred biofilm reactor (CSBR) can be defined as an ideally stirred tank reactor, where the reactions take place in a biofilm attached to impermeable substrata (Wik and Breitholtz 1998). The interactions between the bulk liquid and the biofilm is illustrated in Figure 1.1. The reaction kinetics in the biofilm is generally nonlinear. Using standard modeling assumptions the equations describing the fast dynamics of a CSBR will then, for each substrate, be one nonlinear partial differential equation (PDE) coupled with one linear ordinary differential equation (ODE) for the mixing in the bulk. Wik and Breitholtz (1998) studied the case when the reaction rate can be assumed to depend linearly on the substrate concentration and derived a method that closely approximate the input/output of the linear PDE and the linear ODE with two linear ODEs. A comparison with other methods showed that the Galerkin method (Finlayson 1972) was almost as good and also resulted in close approximations with only two or three ODEs.

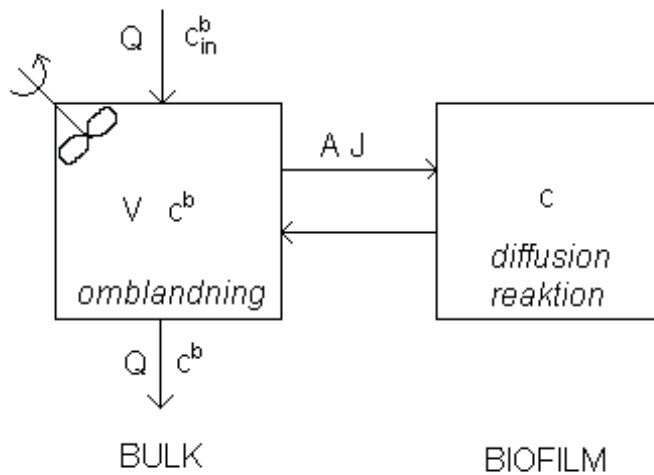

Figure 1.1: *Illustration of a CSBR.*

The most common kinetics for biological substrate uptake is the Monod expression

$$r = \mu_m \frac{X}{Y} \frac{c}{c + K_s}, \quad (1.1)$$

where μ_m is the maximum growth rate, X is the bacterial concentration, Y is the yield coefficient, K_s is a saturation coefficient and c is the substrate concentration.

We see that the Monod expression is only mildly nonlinear in the substrate concentration. Both at low concentrations ($c \ll K_s$) and high concentrations ($c \gg K_s$) the rate is approximately linear. It is therefore reasonable to believe that also for this case it should be possible to use only a few ODEs to approximate the system. Here, it is shown, indeed, how a few nonlinear ordinary differential equations, which may be solved with standard integration methods, can be used as a close approximation. The Residue method by Wik and Breitholtz (1998) requires linear systems and hence, we use the Galerkin method and the orthogonal collocation method which are two standard types of MWR approximations. Approximations achieved with these methods are compared with simulations using the finite element method (FEM). The simulations have been carried out for step responses, impulse responses and responses to random influent concentrations. These comparisons show that there are considerable variations between different types of biofilm reactors and substances. Especially the gain error is quite large for some parameters, but for other parameters the approximations are very accurate, making it possible to have only a second order state space model to approximate the system.

Further, for the second and third order orthogonal collocation method and for the second order Galerkin method it is shown that there is a unique steady state in a domain containing the domain where we expect the solution to be. This stationary solution can be found by solving one single equation. For the second order orthogonal collocation method it is shown that the solution converges to zero for zero influent concentration if the initial solution is physically acceptable. The stationary approximations can either be used as they are or to generate initial values for the dynamic approximation or iterative methods to find stationary solutions of more complicated models used in, for example, simulations of the slow bacterial dynamics. A comparison with the pseudo analytical steady-state solution by Sáez and Rittmann (1992), which appears to be fairly widespread today, shows that the stationary approximation presented here is comparable to the pseudoanalytical one for some parameter values but less accurate for others. However, the methods proposed here also have the advantage of being directly compatible with the dynamic approximations.

It still remains to compare the results from the simplified models to data from experiments. Previous comparisons between data from variations around an operating point as well as trace substance pulse response experiments and simulations with the linear approximations have shown good agreement [Wik and Breitholtz (1998); Wik (1999b)]. The nonlinear approximation can be used for comparison to data from responses to, for example, large step increases in ammonium load.

Chapter 2

NOTATION

Abbreviations

CSBR	continuously stirred biofilm reactor
FEM	finite element method
HRT	hydraulic retention time (d^{-1})
MWR	method of weighted residuals
ODE	ordinary differential equation
PDE	partial differential equation

Capital Letters

A	biofilm area (m^2)
D	diffusion coefficient ($\text{m}^2 \text{d}^{-1}$)
J	substrate flux ($\text{gm}^{-2}\text{d}^{-1}$, mole $\text{m}^{-2}\text{d}^{-1}$)
K_s	saturation coefficient (g m^{-3} , mole m^{-3})
L	biofilm thickness (m)
L_w	liquid film thickness (m)
P_n	Legendre polynomial of order n
T	scaled characteristic time
Q	volumetric flow rate ($\text{m}^3 \text{d}^{-1}$)
V	bulk volume (m^3)
ΔV	water displacement
X	bacterial concentration (gCOD m^{-3})
Y	yield coefficient (gCOD g^{-1})

Small Letters

a	specific surface area (m^{-1})
b	specific decay or maintenance and respiration coefficient (d^{-1})
c	concentration of dissolved component (g m^{-3} , mole m^{-3})
e	error
f	fractional decrease in substrate flux due to the biofilm being shallow instead of deep
f_D	$= D/D^b$ factor describing the relation between the diffusion coefficient in the bulk and in the biofilm
f_L	$= L_w/L$ factor describing the relation between the thickness of the liquid boundary layer and the biofilm thickness
h	mixing height (m)
m	number of state space variables that are used to describe the biofilm in a state space model giving a total state space model of order $m + 1$
p	parameter combination number or product coefficient in factor f expression
q_A	hydraulic load (m^2d^{-1})
q	exponential coefficient in factor f expression
r	reaction rate ($\text{g m}^{-3}\text{d}^{-1}$, $\text{mole m}^{-3}\text{d}^{-1}$)
t	time (d)
x	state space variable

Greek Letters

α	$= L^2\mu_m X/(K_sDY)$ non-dimensional biofilm constant
γ	$= AD/(QL)$ non-dimensional coefficient for substrate flux into biofilm
ϵ	void fraction (m^3m^{-3})
λ	$= D/(L^2\epsilon)$ time-scaling coefficient (d^{-1}) or Lagrange multiplier
μ_m	maximum growth rate (d^{-1})
ν	stoichiometric coefficient
ρ	degree of filling (m^3m^{-3})
ξ	distance from substratum (m)
τ	$= VD/(QL^2\epsilon)$ non-dimensional time constant

Subscripts

<i>deep</i>	deep biofilm
<i>in</i>	influent
<i>rel</i>	relative

Superscripts

b bulk

Diacritical marks

$\hat{}$ approximation or estimate
 $\bar{}$ steady-state
 $\tilde{}$ unscaled
 $*$ scaled

Chapter 3

MODELING

We model a CSBR as a continuously stirred tank with bulk volume V through which there is a flow Q of bulk liquid. The influent concentration is \tilde{c}_{in}^b and the effluent concentration, which equals that in the CSBR, is \tilde{c}^b . The substrate diffuses without transfer resistance into a biofilm where the reactions take place. For the biofilm, the following assumptions are made:

- The substrate concentration (\tilde{c}) in the biofilm is continuous in time (\tilde{t}) and space ($\tilde{\xi}$)
- The void fraction (ϵ) in the biofilm, the substrate diffusion coefficient (D), and the thickness of the biofilm are constant.
- The biofilm is homogeneous.
- The transport of substrates inside the biofilm obeys Fick's law of diffusion in one dimension.

With these assumptions a dimensionless mass-balance over the bulk gives

$$\tau \frac{d}{dt} c^b = c_{in}^b - c^b - \gamma \left. \frac{\partial c}{\partial \xi} \right|_{\xi=1}, \quad (3.1)$$

where the concentration has been scaled as $c^b = \tilde{c}^b/K_s$ and $c = \tilde{c}/K_s$, $\tau = VD/(QL^2\epsilon)$, $\gamma = AD/(QL)$, and space and time are scaled as $\xi = \tilde{\xi}/L$ and $t = \lambda\tilde{t}$, where $\lambda = D/(L^2\epsilon)$. Here, A is the total area of biofilm in the CSBR, and L denotes the value of $\tilde{\xi}$ at the biofilm surface.

The CSBR modeling approach does not require any particular shape of the biofilm substrata or carriers. The model approximations by Wik and Breitholtz (1998) were derived for planar, cylindrical and spherical biofilm substrata, though there were no

significant differences between the methods. For reasons of simplicity, we consider only planar biofilms here. Assuming Monod kinetics according to Eq. (1.1), a mass balance inside the biofilm then gives

$$\frac{\partial c}{\partial t} = \frac{\partial^2 c}{\partial \xi^2} - \alpha \frac{c}{c+1}, \quad 0 < \xi < 1, \quad (3.2)$$

where $\alpha = L^2 \mu_m X / (K_s D Y)$. The boundary conditions are

$$\frac{\partial c}{\partial \xi} = 0, \quad \xi = 0 \quad \text{and} \quad c = c^b, \quad \xi = 1. \quad (3.3)$$

The most straightforward solution of Eqs. (3.1) and (3.2) is to discretize both equations in time and approximate the space derivative in Eq. (3.2) with finite differences, for example. However, this requires a fine discretization of the biofilm due to the large spatial variations of the substrate concentration inside the biofilm.

Chapter 4

MODEL APPROXIMATION

4.1 The Galerkin Method

In the investigation by Wik and Breitholtz (1998) it was shown that the Galerkin method, using Legendre polynomials (Finlayson 1972), could be used to derive low order approximations when the kinetics depended linearly on the substrate concentration. Applying the Galerkin method to the case of Monod kinetics results in similar expressions.

First, we extend the mass balance (3.2) to $-1 < \xi < 1$. The boundary conditions (3.3) then imply that the solution must be symmetric around $\xi = 0$. Hence, we approximate the concentration inside the biofilm with the trial function

$$\hat{c}(t, \xi) = \sum_{k=0}^m x_k(t) P_{2k}(\xi), \quad (4.1)$$

where P_{2k} are Legendre polynomials of order $2k$ (symmetric), orthogonal on $-1 \leq \xi \leq 1$ and normed such that $P_{2k}(1) = 1$. The approximate bulk concentration we get by using this approximation in Eq. (3.1) is denoted \hat{c}^b . Forcing the approximations to satisfy the boundary condition $\hat{c}(1, t) = \hat{c}^b$, setting the weighted residuals of Eq. (3.2) to zero, i.e. setting

$$\int_{-1}^1 P_{2n} \left(\frac{\partial c}{\partial t} - \frac{\partial^2 c}{\partial \xi^2} + \alpha \frac{c}{c+1} \right) d\xi = 0, \quad n = 0, 1, \dots, m, \quad (4.2)$$

and inserting the approximation \hat{c} into Eqs. (3.1) and (4.2) give

$$\sum_{k=0}^m x_k = \hat{c}^b \quad (4.3)$$

$$0 = \sum_{k=0}^m \left\{ (P_{2n}, P_{2k}) \frac{d}{dt} x_k - x_k \left(P_{2n}, \frac{d^2 P_{2k}}{d\xi^2} \right) \right\} + \alpha \left(P_{2n}, \frac{\sum_{k=0}^m x_k P_{2k}}{1 + \sum_{k=0}^m x_k P_{2k}} \right) \quad (4.4)$$

$n = 0, 1, \dots, m$

$$\tau \frac{d}{dt} \hat{c}^b = c_{in}^b - \hat{c}^b - \gamma \sum_{k=0}^m x_k \frac{dP_{2k}}{d\xi} \Big|_{\xi=1} \quad (4.5)$$

where $(u, v) = \int_{-1}^1 uvd\xi$. The fact that

$$(P_{2k}, P_{2n}) = \begin{cases} 0, & k \neq n \\ \frac{2}{4n+1}, & k = n \end{cases}$$

$$\left(P_{2n}, \frac{d^2 P_{2k}}{d\xi^2} \right) = 0 \quad \forall n \geq k$$

simplifies the calculations. To achieve a state space model we may use the first algebraic equation (4.3) to eliminate one differential equation, i.e., either (4.5) or one of (4.4).

It is in the last term of Eq. (4.4) that the nonlinearities are introduced in the approximation. Unfortunately, that term becomes quite cumbersome as m becomes large. However, when $m = 1$ the expressions are quite simple and the approximate state space model of a CSBR can be formulated as

$$\frac{d}{dt} x_0 = \begin{cases} 3(\hat{c}^b - x_0) - \alpha \left(1 - \frac{1}{1.5(\hat{c}^b - x_0)\sqrt{g}} \tan^{-1} \sqrt{\frac{1}{g}} \right) & \text{if } g \geq 0 \\ 3(\hat{c}^b - x_0) - \alpha \left(1 - \frac{0.5}{1.5(\hat{c}^b - x_0)\sqrt{-g}} \ln \left| \frac{1 - \sqrt{-g}}{1 + \sqrt{-g}} \right| \right) & \text{if } g < 0 \end{cases} \quad (4.6)$$

$$\frac{d}{dt} \hat{c}^b = \frac{1}{\tau} (c_{in}^b - (1 + 3\gamma)\hat{c}^b + 3\gamma x_0) \quad (4.7)$$

where

$$g = \frac{1 + 1.5x_0 - 0.5\hat{c}^b}{1.5(\hat{c}^b - x_0)}. \quad (4.8)$$

When g is in the interval $(-1, 0)$ the integral in the last term of Eq. (4.4) contains a singularity. However the integral can be calculated as

$$(u, v) = \int_{-1}^1 uvd\xi = 2 \int_0^1 uvd\xi = \lim_{\epsilon \rightarrow 0} \left(2 \int_0^{s-\epsilon} uvd\xi + 2 \int_{s+\epsilon}^1 uvd\xi \right) \quad (4.9)$$

where s is the value of ξ which gives the singularity. This results in the above expressions for \dot{x}_0 .

The approximation of the concentration in the biofilm is

$$\hat{c}(\xi, t) = x_0(t) + (1.5\xi^2 - 0.5)(\hat{c}^b(t) - x_0(t)).$$

Also when $m = 2$ it is possible to find an analytical expression for the last term of Eq. (4.4). In this case the state space model can be formulated as

$$\frac{d}{dt}x_0 = 10(\hat{c}^b - x_0) - 7x_1 - \alpha\left(1 - \frac{1}{g_3}\left(\phi\left(\frac{g_1 - g_3}{2g_2}\right) + \phi\left(\frac{g_1 + g_3}{2g_2}\right)\right)\right) \quad (4.10)$$

$$\frac{d}{dt}x_1 = 35(\hat{c}^b - x_0 - x_1) + \frac{5\alpha}{2g_3}\left(\psi\left(\frac{g_1 + g_3}{2g_2}\right) - \psi\left(\frac{g_1 - g_3}{2g_2}\right)\right) \quad (4.11)$$

$$\frac{d}{dt}\hat{c}^b = \frac{1}{\tau}(c_{in}^b - (1 + 10\gamma)\hat{c}^b + 10\gamma x_0 + 7\gamma x_1) \quad (4.12)$$

where

$$\phi(z) = \begin{cases} \frac{0.5}{\sqrt{-z}} \ln \left| \frac{1-\sqrt{-z}}{1+\sqrt{-z}} \right| & \text{if } z < 0 \text{ and } Im(z) = 0 \\ \frac{1}{\sqrt{z}} \tan^{-1} \frac{1}{\sqrt{z}} & \text{else} \end{cases} \quad (4.13)$$

$$\psi(z) = \begin{cases} 1.5\sqrt{-z} \ln \left| \frac{1-\sqrt{-z}}{1+\sqrt{-z}} \right| - \phi(z) & \text{if } z < 0 \text{ and } Im(z) = 0 \\ 3\sqrt{z} \tan^{-1} \frac{1}{\sqrt{z}} - \phi(z) & \text{else} \end{cases} \quad (4.14)$$

and

$$g_0 = 1 + 0.625x_0 - 0.875x_1 + 0.375\hat{c}^b \quad (4.15)$$

$$g_1 = 5.25x_1 - 3.75(\hat{c}^b - x_0) \quad (4.16)$$

$$g_2 = 4.375(\hat{c}^b - x_0 - x_1) \quad (4.17)$$

$$g_3 = \sqrt{g_1^2 - 4g_0g_2}. \quad (4.18)$$

Again, the integral may contain a singularity, but if it is calculated according to Eq. (4.9) we get the above expressions for ϕ and ψ .

The approximation of the concentration in the biofilm is

$$\hat{c}(\xi, t) = x_0(t) + (1.5\xi^2 - 0.5)x_1(t) + (4.375\xi^4 - 3.75\xi^2 + 0.375)(\hat{c}^b(t) - x_0(t) - x_1(t)).$$

4.1.1 Steady State Model

For the stationary solution the following should hold.

$$\begin{aligned} 0 &\leq \hat{c}(0) = 1.5x_0 - 0.5\hat{c}^b \\ 0 &\leq \left. \frac{d\hat{c}}{d\xi} \right|_{\xi=1} = 3(\hat{c}^b - x_0) \end{aligned}$$

Eq. (4.8) then gives that $g > 0$. This means that we can use the first row of Eq. (4.6) containing the *arctan* expression to determine the steady state. By setting the time derivatives in Eqs. (4.6) and (4.7) to zero we can determine the stationary solution corresponding to an influent concentration \bar{c}_{in}^b for the second order state space model ($m = 1$). If we use $y = (\bar{c}_{in}^b - \bar{c}^b)/2\gamma$, the steady state is given by

$$f(y) = 2y - \alpha \left(1 - \frac{1}{y} \sqrt{\frac{y}{h(y)}} \tan^{-1} \sqrt{\frac{y}{h(y)}} \right) = 0, \quad (4.19)$$

where $h(y) = 1 + \bar{c}_{in}^b - (1 + 2\gamma)y$. After solving this equation with a Newton Raphson method, for example, the stationary bulk concentration and the concentration in the biofilm follows from

$$\bar{c}^b = \bar{c}_{in}^b - 2\gamma y \quad (4.20)$$

$$\bar{c}(\xi) = \bar{c}_{in}^b - (1 + 2\gamma)y + \xi^2 y. \quad (4.21)$$

4.2 The Orthogonal Collocation Method

One of the drawbacks of the Galerkin method in this case is the difficulty to formulate simple expressions for the last term of Eq. (4.4) when m becomes large. This problem is avoided when the orthogonal collocation method is used since the residual is evaluated at discrete points and not over the whole interval. Villadsen and Michelsen (1978) showed that for the general nonlinear case, the optimal collocation method is the same as the Galerkin method where the integrals are evaluated by optimal quadrature formulas. In our case this means that for $m > 2$, where we have no analytical expression for the integrals of the Galerkin method, there is no need to use quadrature to evaluate the integrals since the orthogonal collocation method will then give the same or better results.

As in the Galerkin method we first extend the mass balance (3.2) to $-1 < \xi < 1$. To force the solution to be symmetric around $\xi = 0$ we also use the same trial function as earlier.

$$\hat{c}(t, \xi) = \sum_{k=0}^m x_k(t) P_{2k}(\xi) \quad (4.22)$$

The boundary condition and the equation for the approximative bulk concentration is the same as for the Galerkin method. Setting the residuals to zero at $m + 1$ collocation points ξ_j gives the following equations.

$$0 = \sum_{k=0}^m \left\{ P_{2k}(\xi_j) \frac{d}{dt} x_k - x_k \frac{d^2 P_{2k}}{d\xi^2} \Big|_{\xi=\xi_j} \right\} + \alpha \frac{\sum_{k=0}^m x_k P_{2k}(\xi_j)}{1 + \sum_{k=0}^m x_k P_{2k}(\xi_j)} \quad (4.23)$$

$j = 1, 2, \dots, m + 1$

The algebraic equation (4.3) is used to eliminate one differential equation. This means that we only need m collocation points. These m collocation points are

taken as the positive roots of the Legendre polynomial P_{2m} . The resulting state space model can then be written as follows:

$$\begin{aligned} \sum_{k=0}^{m-1} \frac{d}{dt} x_k P_{2k}(\xi_j) &= \sum_{k=0}^{m-1} x_k \left(\frac{d^2 P_{2k}}{d\xi^2} - \frac{d^2 P_{2m}}{d\xi^2} \right) \Big|_{\xi=\xi_j} + \\ &+ \hat{c}^b \frac{d^2 P_{2m}}{d\xi^2} \Big|_{\xi=\xi_j} - \alpha \left(\frac{\sum_{k=0}^{m-1} x_k P_{2k}(\xi_j)}{1 + \sum_{k=0}^{m-1} x_k P_{2k}(\xi_j)} \right) \\ & \quad j = 1, 2, \dots, m \end{aligned} \quad (4.24)$$

$$\begin{aligned} \frac{d}{dt} \hat{c}^b &= \frac{1}{\tau} (c_{in}^b - \hat{c}^b) \\ &- \frac{\gamma}{\tau} \left(\sum_{k=0}^{m-1} x_k \left(\frac{dP_{2k}}{d\xi} - \frac{dP_{2m}}{d\xi} \right) \Big|_{\xi=1} + \hat{c}^b \frac{dP_{2m}}{d\xi} \Big|_{\xi=1} \right) \end{aligned} \quad (4.25)$$

Below, the state space model is given in matrix notation.

$$\begin{aligned} \begin{bmatrix} & & 0 \\ & \tilde{M} & \vdots \\ & & 0 \\ 0 & \dots & 0 & 1 \end{bmatrix} \begin{bmatrix} \dot{x}_0 \\ \vdots \\ \dot{x}_{m-1} \\ \dot{\hat{c}}^b \end{bmatrix} &= \begin{bmatrix} \bar{A} - \tilde{A}1_m & \tilde{A} \\ -\frac{\gamma}{\tau}(\Gamma - \Phi 1_m) & -\frac{1}{\tau}(1 + \gamma\Phi) \end{bmatrix} \begin{bmatrix} x_0 \\ \vdots \\ x_{m-1} \\ \hat{c}^b \end{bmatrix} + \\ &+ \begin{bmatrix} 0 \\ \vdots \\ 0 \\ \frac{1}{\tau} \end{bmatrix} c_{in}^b + \begin{bmatrix} \tilde{\varphi} \\ 0 \end{bmatrix} \end{aligned} \quad (4.26)$$

where

$$\begin{aligned} \tilde{M}_{ij} &= P_{2(j-1)}(\xi_i) & i = 1, \dots, m \quad j = 1, \dots, m \\ \bar{A}_{ij} &= \frac{d^2 P_{2(j-1)}}{d\xi^2} \Big|_{\xi_i} & i = 1, \dots, m \quad j = 1, \dots, m \\ \tilde{A}_i &= \frac{d^2 P_{2m}}{d\xi^2} \Big|_{\xi_i} & i = 1, \dots, m \\ \Gamma_j &= \frac{dP_{2(j-1)}}{d\xi} \Big|_{\xi=1} & j = 1, \dots, m \\ \Phi &= \frac{dP_{2m}}{d\xi} \Big|_{\xi=1} \\ \tilde{\varphi}_i(x) &= \alpha \left(-1 + \frac{1}{1 + \sum_{k=0}^{m-1} x_k P_{2k}(\xi_i)} \right) & i = 1, \dots, m \end{aligned}$$

and 1_m is the vector with m elements that equals one.

When $m = 1$ the state space model can be written as

$$\begin{aligned} \frac{d}{dt} x_0 &= 3(\hat{c}^b - x_0) - \frac{\alpha x_0}{1 + x_0} \\ \frac{d}{dt} \hat{c}^b &= \frac{1}{\tau} (c_{in}^b - (1 + 3\gamma)\hat{c}^b + 3\gamma x_0). \end{aligned}$$

Expanding to $m = 2$ the state space model can be written as follows.

$$\begin{aligned}\frac{d}{dt}x_0 &= 10(\hat{c}^b - x_0) - 7x_1 + \alpha \left(-1 + \frac{0.6521}{1 + x_0 - 0.3266x_1} + \frac{0.3479}{1 + x_0 + 0.6123x_1} \right) \\ \frac{d}{dt}x_1 &= 35(\hat{c}^b - x_0 - x_1) + \alpha \left(-\frac{1.0652}{1 + x_0 - 0.3266x_1} + \frac{1.0652}{1 + x_0 + 0.6123x_1} \right) \\ \frac{d}{dt}\hat{c}^b &= \frac{1}{\tau}(c_{in}^b - (1 + 10\gamma)\hat{c}^b + 10\gamma x_0 + 7\gamma x_1).\end{aligned}$$

4.2.1 Steady State Model

The steady state solution for the orthogonal collocation method is determined by setting the derivatives of Eq. (4.24) and (4.25) to zero. If we use $y = (\bar{c}_{in}^b - \hat{c}^b)/2\gamma$ the steady state for $m = 1$ is given by

$$f(y) = 2y - \alpha \left(1 - \frac{3}{3(1 + c_{in}^b) - 2(1 + 3\gamma)y} \right) = 0. \quad (4.27)$$

The stationary bulk concentration and the concentration in the biofilm follows from

$$\bar{c}^b = \bar{c}_{in}^b - 2\gamma y \quad (4.28)$$

$$\bar{c}(\xi) = \bar{c}_{in}^b - (1 + 2\gamma)y + \xi^2 y. \quad (4.29)$$

With $y = (c_{in}^b - \hat{c}^b)/10\gamma$ the steady state for $m = 2$ is given by

$$\begin{aligned}f(y) &= (y - 0.3g(y)) \frac{d^2 P_4}{d\xi^2} \Big|_{\xi=\xi_2} + 3g(y) \\ &\quad - \alpha \left(1 - \frac{1}{1 + c_{in}^b - (1 + 10\gamma)y + (P_2(\xi_2) - 0.7)g(y)} \right)\end{aligned}$$

where

$$\begin{aligned}g(y) &= \frac{-b(y) \pm \sqrt{b^2(y) - 4ac(y)}}{2a} \\ a &= \left(3 - 0.3 \frac{d^2 P_4}{d\xi^2} \Big|_{\xi=\xi_1} \right) (P_2(\xi_1) - 0.7) \\ b(y) &= \left(3 - 0.3 \frac{d^2 P_4}{d\xi^2} \Big|_{\xi=\xi_1} \right) (1 + c_{in}^b - (1 + 10\gamma)y) + \\ &\quad + \left(\frac{d^2 P_4}{d\xi^2} \Big|_{\xi=\xi_1} y - \alpha \right) (P_2(\xi_1) - 0.7) \\ c(y) &= \left(\frac{d^2 P_4}{d\xi^2} \Big|_{\xi=\xi_1} y - \alpha \right) (1 + c_{in}^b - (1 + 10\gamma)y) + \alpha.\end{aligned}$$

The stationary bulk concentration and the biofilm concentration then follows from

$$\bar{c}^b = c_{in}^b - 10\gamma y \quad (4.30)$$

$$\bar{c}(\xi) = c_{in}^b - (1 + 10\gamma)y - 0.7g(y) + P_2(\xi)g(y) + P_4(\xi)(y - 0.3g(y)). \quad (4.31)$$

4.3 The Subdomain Method

An advantage of the subdomain method is that the mass balances are automatically satisfied on each subdomain. This follows from the fact that the weight function is equal to one on each subdomain. The residual is simply the mass balance at one point. Integrating the residual (the mass balance at one point) over the interval and setting the integral to zero then clearly makes the mass balance satisfied on that interval. We start with the same trial function as before.

$$\hat{c}(t, \xi) = \sum_{k=0}^m x_k(t)P_{2k}(\xi) \quad (4.32)$$

This gives the same boundary conditions and the same bulk concentration equation as earlier.

Dividing the whole domain into subdomains (ξ_i, ξ_{i+1}) and setting the integral of the residual over the these intervals to zero result in the following equations.

$$0 = \sum_{k=0}^m \left\{ \frac{d}{dt} x_k \int_{\xi_j}^{\xi_{j+1}} P_{2k} d\xi - x_k \int_{\xi_j}^{\xi_{j+1}} \frac{d^2 P_{2k}}{d\xi^2} d\xi \right\} + \dots$$

$$+ \alpha \left(\xi_{j+1} - \xi_j - \int_{\xi_j}^{\xi_{j+1}} \frac{d\xi}{1 + \sum_{k=0}^m x_k P_{2k}} \right)$$

$$j = 0, 1, \dots, m \quad (4.33)$$

Eliminating x_m using the boundary condition makes it possible to reduce the number of subdomains by one. Hence, $j = 0, 1, \dots, m - 1$. Naturally $\xi_0 = 0$ and $\xi_{m-1} = 1$.

As for the Galerkin method, finding an analytical solution of the last integral in Eq. (4.33) becomes quite difficult when m becomes large. However, for $m = 1$ it turns out that the Subdomain method gives exactly the same approximation as the Galerkin method. Also for $m = 2$ the Subdomain approximation shows a close resemblance to the Galerkin approximation. Because of this, the Subdomain approximation will not be analysed further.

4.4 Diffusion Layer on the Biofilm Surface

The model that we have derived and used for the approximations does not take into account the effects of a boundary layer on the surface of the biofilm. It has been shown that the thickness of the boundary layer decrease with increased flow velocities over the biofilm. This improves the mass transfer into the biofilm, which means that it is advantageous to design and operate biofilm reactors under conditions such that the effect of the boundary layer can be ignored (Wik 1999a). Hence, the assumption that the resistance in the diffusion layer can be neglected is appropriate in many cases.

However, if a boundary layer of depth L_w has developed, the boundary condition at the biofilm surface can be written

$$-D \frac{\partial \tilde{c}}{\partial \tilde{\xi}} \Big|_{\tilde{\xi}=L} = -\frac{D^b}{L_w} (c^b(\tilde{t}) - \tilde{c}(L, \tilde{t})), \quad (4.34)$$

where D^b is the diffusion coefficient in the bulk, D is the molecular diffusion coefficient in the biofilm and L is the biofilm thickness. Multiplying both sides of (4.34) by L_w and letting L_w tend to zero, we see that we get the same boundary condition as before.

For the approximations this boundary condition becomes

$$\sum_{k=0}^m x_k \frac{dP_{2k}}{d\xi} \Big|_{\xi=1} = \frac{D^b L}{D L_w} \left(\hat{c}^b - \sum_{k=0}^m x_k \right) = \frac{1}{f_D f_L} \left(\hat{c}^b - \sum_{k=0}^m x_k \right), \quad (4.35)$$

where the variables are scaled as in Eqs. (3.1) and (3.2). This algebraic equation can be used instead of (4.3) to eliminate one differential equation.

A state space model for the second order Galerkin approximation ($m = 1$) can then be written as follows:

$$\frac{d}{dt} x_0 = \begin{cases} 3 \left(\frac{\hat{c}^b - x_0}{3f_D f_L + 1} \right) - \alpha \left(1 - \frac{3f_D f_L + 1}{1.5(\hat{c}^b - x_0)\sqrt{g}} \tan^{-1} \sqrt{\frac{1}{g}} \right) & \text{if } g \geq 0 \\ 3 \left(\frac{\hat{c}^b - x_0}{3f_D f_L + 1} \right) - \alpha \left(1 - \frac{3f_D f_L + 1}{3(\hat{c}^b - x_0)\sqrt{-g}} \ln \left| \frac{1 - \sqrt{-g}}{1 + \sqrt{-g}} \right| \right) & \text{if } g < 0 \end{cases} \quad (4.36)$$

$$\frac{d}{dt} \hat{c}^b = \frac{1}{\tau} (c_{in}^b - \hat{c}^b - 3\gamma \left(\frac{\hat{c}^b - x_0}{3f_D f_L + 1} \right)), \quad (4.37)$$

where

$$g = \frac{(1 + x_0)(3f_D f_L + 1) - 0.5(\hat{c}^b - x_0)}{1.5(\hat{c}^b - x_0)}. \quad (4.38)$$

When $m = 2$ the state space model is

$$\frac{d}{dt}x_0 = 10 \left(\frac{\hat{c}^b - x_0 - x_1 - 3f_D f_L x_1}{10f_D f_L + 1} \right) + 3x_1 - \alpha \left(1 - \frac{1}{g_3} \left(\phi\left(\frac{g_1 - g_3}{2g_2}\right) + \phi\left(\frac{g_1 + g_3}{2g_2}\right) \right) \right) \quad (4.39)$$

$$\frac{d}{dt}x_1 = 35 \left(\frac{\hat{c}^b - x_0 - x_1 - 3f_D f_L x_1}{10f_D f_L + 1} \right) + \frac{5\alpha}{2g_3} \left(\psi\left(\frac{g_1 + g_3}{2g_2}\right) - \psi\left(\frac{g_1 - g_3}{2g_2}\right) \right) \quad (4.40)$$

$$\frac{d}{dt}\hat{c}^b = \frac{1}{\tau} (\hat{c}_{in}^b - \hat{c}^b - \gamma (10 \left(\frac{\hat{c}^b - x_0 - x_1 - 3f_D f_L x_1}{10f_D f_L + 1} \right) + 3x_1)) \quad (4.41)$$

where

$$\phi(z) = \begin{cases} \frac{0.5}{\sqrt{-z}} \ln \left| \frac{1 - \sqrt{-z}}{1 + \sqrt{-z}} \right| & \text{if } z < 0 \text{ and } Im(z) = 0 \\ \frac{1}{\sqrt{z}} \tan^{-1} \frac{1}{\sqrt{z}} & \text{else} \end{cases} \quad (4.42)$$

$$\psi(z) = \begin{cases} 1.5\sqrt{-z} \ln \left| \frac{1 - \sqrt{-z}}{1 + \sqrt{-z}} \right| - \phi(z) & \text{if } z < 0 \text{ and } Im(z) = 0 \\ 3\sqrt{z} \tan^{-1} \frac{1}{\sqrt{z}} - \phi(z) & \text{else} \end{cases} \quad (4.43)$$

and

$$g_0 = 1 + x_0 - 0.5x_1 + 0.375 \left(\frac{\hat{c}^b - x_0 - x_1 - 3f_D f_L x_1}{10f_D f_L + 1} \right) \quad (4.44)$$

$$g_1 = 1.5x_1 - 3.75 \left(\frac{\hat{c}^b - x_0 - x_1 - 3f_D f_L x_1}{10f_D f_L + 1} \right) \quad (4.45)$$

$$g_2 = 4.375 \left(\frac{\hat{c}^b - x_0 - x_1 - 3f_D f_L x_1}{10f_D f_L + 1} \right) \quad (4.46)$$

$$g_3 = \sqrt{g_1^2 - 4g_0g_2}. \quad (4.47)$$

Finally, the orthogonal collocation method results in the following approximation.

$$\begin{aligned} \sum_{k=0}^{m-1} \frac{d}{dt} x_k P_{2k}(\xi_j) &= \sum_{k=0}^{m-1} x_k \left\{ \frac{d^2 P_{2k}}{d\xi^2} \Big|_{\xi=\xi_j} - \left(\frac{f_D f_L \frac{dP_{2k}}{d\xi} \Big|_{\xi=1} + 1}{f_D f_L \frac{dP_{2m}}{d\xi} \Big|_{\xi=1} + 1} \right) \frac{d^2 P_{2m}}{d\xi^2} \Big|_{\xi=\xi_j} \right\} + \\ &+ \hat{c}^b \left(\frac{1}{f_D f_L \frac{dP_{2m}}{d\xi} \Big|_{\xi=1} + 1} \right) \frac{d^2 P_{2m}}{d\xi^2} \Big|_{\xi=\xi_j} \\ &- \alpha \left(\frac{\sum_{k=0}^{m-1} x_k P_{2k}(\xi_j)}{1 + \sum_{k=0}^{m-1} x_k P_{2k}(\xi_j)} \right) \quad j = 1, 2, \dots, m \quad (4.48) \end{aligned}$$

$$\begin{aligned} \frac{d}{dt} \hat{c}^b &= \frac{1}{\tau} (\hat{c}_{in}^b - \hat{c}^b) + \frac{\gamma}{\tau} \hat{c}^b \left(\frac{1}{f_D f_L \frac{dP_{2m}}{d\xi} \Big|_{\xi=1} + 1} \right) \frac{dP_{2m}}{d\xi} \Big|_{\xi=1} - \\ &\frac{\gamma}{\tau} \sum_{k=0}^{m-1} x_k \left\{ \frac{dP_{2k}}{d\xi} \Big|_{\xi=1} - \left(\frac{f_D f_L \frac{dP_{2k}}{d\xi} \Big|_{\xi=1} + 1}{f_D f_L \frac{dP_{2m}}{d\xi} \Big|_{\xi=1} + 1} \right) \frac{dP_{2m}}{d\xi} \Big|_{\xi=1} \right\} \quad (4.49) \end{aligned}$$

Chapter 5

MODEL PROPERTIES

Two properties of the approximate model are particularly important. From experience we have no reason to believe that a biofilm reactor fed with constant substrate concentration at a constant flow would become unstable, i.e., the effluent concentration should also be constant. Neither have we any reason to believe that this constant effluent concentration would not be the same independently of prior influent conditions. Mathematically, these properties are the uniqueness and the stability of the systems equilibrium points. In the following two sections these properties of the proposed model approximations will be discussed.

5.1 Uniqueness

Finding the solution of the steady state model is easier if we know in which interval the solution is expected to be. For the second order steady state approximations ($m = 1$) the following should hold.

$$0 \leq \hat{c}^b \leq c_{in}^b \quad (5.1)$$

$$0 \leq \hat{c}(0) = 1.5x_0 - 0.5\hat{c}^b \quad (5.2)$$

$$0 \leq \left. \frac{d\hat{c}}{d\xi} \right|_{\xi=1} = 3(\hat{c}^b - x_0) \quad (5.3)$$

In steady state, $x_0 = \hat{c}^b + (\hat{c}^b - c_{in}^b)/3\gamma$. This is true for both the Galerkin method and the orthogonal collocation method. Together with the statements above this gives the interval

$$c_{in}^b/(1 + 2\gamma) \leq \hat{c}^b \leq c_{in}^b$$

for the solution. We will show that there is a unique steady state solution to the approximations in this interval for $m = 1$.

5.1.1 The Galerkin Method

A general problem with nonlinear systems like the ones presented here is the possibility of multiple steady states. However, for the Galerkin method when $m = 1$ it can be shown that there is a unique stationary solution to (4.19) in the interval $(c_{in}^b - 2\gamma)/(1 + 2\gamma) < \bar{c}^b < c_{in}^b$. Notice that this interval is larger than the expected interval for the solution.

It is easily shown that g is positive in the interval, which means that we should use the first row of Eq. (4.6) containing the *arctan* expression in the investigation. From Eq. (4.20) we see that the interval translates into $0 < y < (1 + c_{in}^b)/(1 + 2\gamma)$. Investigating Eq. (4.19) on the end points of this interval, we have

$$\lim_{y \rightarrow 0} f(y) = -\alpha \frac{c_{in}^b}{1 + c_{in}^b} < 0$$

since $g(y) > 0$ and $\lim_{\delta \rightarrow 0} \tan^{-1} \delta = \delta$. Further, we have

$$f(y) \rightarrow \infty \quad \text{when} \quad y \rightarrow \frac{1 + c_{in}^b}{1 + 2\gamma}.$$

Since $f(y)$ is a continuous function on the interval there exists at least one solution to Eq. (4.19). If $f(y)$ is also a monotonically increasing function on the interval, the solution is unique.

With $a = (1 + c_{in}^b)$, $b = 1 + 2\gamma$ and $z = y/(a - by)$, we have $a > 1$, $b > 1$ and that z increase monotonically with y from 0 to ∞ as y goes from 0 to a/b . Let

$$m(z) = \frac{a}{\alpha}(f(y) + \alpha - 2y) = (1 + bz) \frac{\tan^{-1} \sqrt{z}}{\sqrt{z}}.$$

We then have

$$\frac{d}{dz} m(z) = \underbrace{\frac{b}{2\sqrt{z}} \tan^{-1} \sqrt{z}}_{>0} + \underbrace{\frac{1}{2z}}_{>0} \left(\underbrace{\frac{1 + bz}{1 + z}}_{>1} - \underbrace{\frac{\tan^{-1} \sqrt{z}}{\sqrt{z}}}_{<1} \right) > 0 \quad \forall z > 0.$$

i.e., $m(z)$ increases monotonically with z . Hence, $f(y)$ increases monotonically with y on the interval $0 < y < a/b$ and the steady state solution (4.20) and (4.21) is unique.

5.1.2 The Orthogonal Collocation Method

For the orthogonal collocation method with $m = 1$ it can be shown that there is a unique steady state solution to (4.27) in the interval $(c_{in}^b - 3\gamma)/(1 + 3\gamma) < \bar{c}^b < c_{in}^b$. Again, this interval is larger than the expected one.

According to Eq. (4.28) this interval translates into $0 < y < 3(1 + c_{in}^b)/(2(1 + 3\gamma))$. We have

$$\lim_{y \rightarrow 0} f(y) = -\alpha \frac{c_{in}^b}{1 + c_{in}^b} < 0$$

and

$$f(y) \rightarrow \infty \quad \text{when} \quad y \rightarrow \frac{3(1 + c_{in}^b)}{2(1 + 3\gamma)}.$$

Since $f(y)$ is a continuous function on the interval there exists at least one solution to Eq. (4.19).

$$\frac{d}{dy} f(y) = 2 + 3\alpha \left(\frac{2(1 + 3\gamma)}{(3(1 + c_{in}^b) - 2(1 + 3\gamma)y)^2} \right) > 0$$

The derivative of $f(y)$ is strictly positive which means that the function is monotonically increasing on the interval and hence the solution is unique.

5.2 Convergence

It is difficult to show stability for nonlinear systems, but for the orthogonal collocation approximation with $m = 1$ it is possible to show that the solution converges to $x_0 = c^b = 0$ if the initial solution is in the domain $D \equiv \{x_0, c^b : x_0 > 0, c^b > 0\}$ when $c_{in}^b = 0$. It is reasonable to restrict the states to be in this domain, since it corresponds to all concentrations being positive.

5.2.1 The Orthogonal Collocation Method

First we will show that all solutions that start in D remain in D for small enough timesteps. As $\Delta t \rightarrow 0$ we have

$$\begin{aligned} x_0(t + \Delta t) &= \dot{x}_0 \Delta t + x_0(t) = 3c^b(t) \Delta t + x_0(t)(1 - 3\Delta t) - \frac{\alpha x_0(t)}{1 + x_0(t)} \Delta t \\ &\geq 3c^b(t) \Delta t + x_0(t)(1 - (3 + \alpha)\Delta t) \\ &\Rightarrow x_0(t + \Delta t) \geq 0 \quad \text{since} \quad \Delta t \rightarrow 0 \end{aligned}$$

$$\begin{aligned} c^b(t + \Delta t) &= \dot{c}^b \Delta t + c^b(t) = \frac{3\gamma}{\tau} x_0(t) \Delta t + c^b(t) \left(1 - \frac{1}{\tau} (1 + 3\gamma) \Delta t\right) \\ &\Rightarrow c^b(t + \Delta t) \geq 0 \quad \text{since} \quad \Delta t \rightarrow 0 \end{aligned}$$

Hence, the solution will remain in the domain D .

Now we will show that there is a function V such that $V \geq 0 \quad \forall (x_0, c^b) \in D$, where equality only holds when $x_0 = 0$ and $c^b = 0$.

$$V = c^b + \frac{\gamma}{\tau} x_0$$

Further $\dot{V} \leq 0 \quad \forall (x_0, c^b) \in D$. Again, equality only holds for $x_0 = 0$ and $c^b = 0$.

$$\dot{V} = \dot{c}^b + \frac{\gamma}{\tau} \dot{x}_0 = -\frac{c^b}{\tau} - \alpha \frac{\gamma}{\tau} \underbrace{\left(1 - \frac{1}{1+x_0}\right)}_{\leq 1} \leq 0$$

The existence of a function V with the above properties, together with the fact that all solutions $x \in D$ remain in D gives that for any initial solution in D , the solution will converge to the steady state $x_0 = 0, c^b = 0$.

A phase plane analysis confirms that the solution will converge to zero, when the both x_0 and \hat{c}^b in the initial solution is positive (see Figure 5.1).

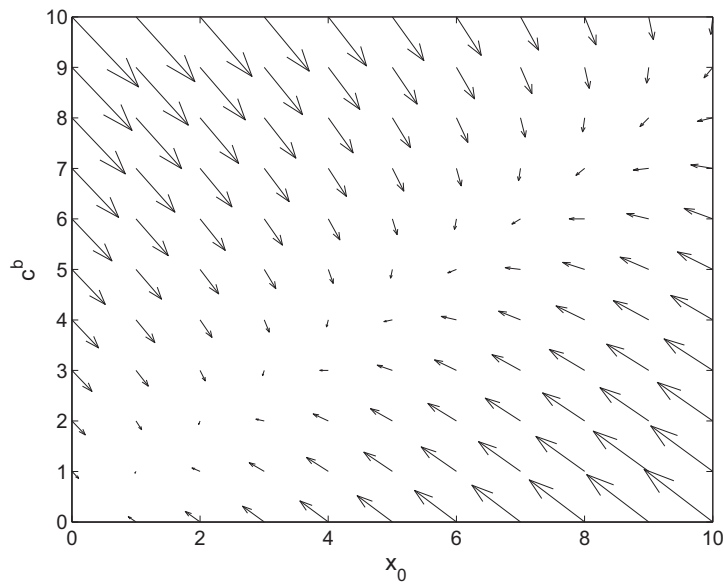

Figure 5.1: Phase plane plot showing the convergence of a solution to zero.

Chapter 6

SIMULATION

6.1 Parameter Choices

The simulations were carried out for a number of different combinations of parameters α , γ and τ/γ . The values for these parameters were chosen as the typical values for some different biofilms and reactors.

The three types of biofilms considered were:

- Aerobic growth of autotrophs
- Aerobic growth of heterotrophs
- Anoxic growth of heterotrophs

Two types of biofilm reactors were considered. These were:

- High rate trickling filters
- Moving bed bioreactors

Typical values of parameters describing these biofilms and reactors can be found in Appendix A.

Dynamic simulations were run for all combinations of $\alpha = 0.003, 0.03, 1, 30, 300$; $\gamma = 0.1, 0.33, 1, 3, 10$; and $\tau/\gamma = 0.02, 0.1, 1, 10, 50$. These combinations gave a total of 125 simulations covering typical cases for all the considered biofilms and reactors.

The parameter combination given by the i_α^{th} α -value, the i_γ^{th} γ -value and the $i_{\tau/\gamma}^{th}$ value of τ/γ has the number

$$p = 25(i_\alpha - 1) + 5(i_\gamma - 1) + i_{\tau/\gamma}. \quad (6.1)$$

6.2 Error Estimation

To estimate the approximation error the MWR approximation and a FEM solution was compared. For the dynamic simulations the error was calculated as

$$e_{rel} = \frac{\int_0^{5T} |c_{FEM}^b - \hat{c}^b| dt}{\int_0^{5T} c_{FEM}^b dt} \quad (6.2)$$

where c_{FEM}^b is the FEM solution, \hat{c}^b is the MWR solution and T is the scaled characteristic time ($\tilde{T} = (V + \epsilon AL)/Q \Rightarrow T = \tau + \gamma$). The integrals were evaluated by quadrature using the MATLAB function *quad*.

As a measure of accuracy of the steady state simulations, the relative error was calculated according to

$$e_{rel} = \frac{|\hat{c}^b - c_{FEM}^b|}{c_{FEM}^b}. \quad (6.3)$$

Since the FEM solution is also an approximation, although more accurate, small errors have to be regarded as negligible.

6.3 FEM Simulation

The FEM simulation was carried out in FEMLAB. It is rather straight-forward to state the coefficients of the PDE. To be able to solve the ODE however, it has to be given in weak form. The term containing the concentration gradient at the biofilm surface should not be given explicitly. That term will be added automatically when the problem is given in weak form and the PDE and ODE are coupled through the boundary condition $c(1) = c^b$. Since we use the weak form this condition is translated into $\lambda_{test}(c^b - c(1)) + \lambda(c_{test}^b - c_{test}(1))$ where λ is the Lagrange multiplier. The Neumann condition becomes $\nabla c = \lambda$ when we use a Dirichlet boundary condition $c(1) = c^b$. The term λc_{test}^b will be added to the ODE since it contains c_{test}^b . As a result we get ∇c at $\xi = 1$ as a term in the ODE. (Comsol 2003)

For the FEM solver the absolute tolerance was set to 10^{-5} and the relative tolerance to $\tau 10^{-4}$ when $\tau < 1$ and 10^{-4} else. The reason for having τ as a factor in the

relative tolerance is that the initial value of c^b for an impulse response is $1/\tau$. Hence for low values of τ the initial value of c^b is high and a low relative tolerance does not guarantee a small absolute error. The number of node points were 305, and the node points were closer to each other near $\xi = 1$. This was done by initializing a mesh by setting the maximum general element size to $1/120$, the maximum element size near the vertex $\xi = 1$ to $1/4000$ and the mesh growth rate to 1.3. Then the mesh was refined once. The rest of the solver settings had their default values.

The accuracy of the numerical results from the FEM calculations was verified by decreasing the number of node points to half and increasing the absolute and relative tolerance to 10^{-4} and 10^{-3} (or $\tau 10^{-3}$) respectively, for some parameter combinations. This had negligible effects on the numerical results. As an example, the error according to Eq. (6.2) between the FEM solution calculated with these conditions and the FEM solution used in comparison with the approximations was less than 0.001% for a unit step response when $\alpha = 300$, $\gamma = 3$ and $\tau/\gamma = 10$.

In steady state, the ODE can be eliminated and the PDE can be solved using the MATLAB toolbox FEMLAB in a quite straightforward manner. The calculations are fast compared to the dynamic simulations and the error tolerances can be set to rather low values. The iterative tolerance for the FEM solution was then set to $1e^{-8}$.

6.4 Steady State Models

The stationary approximations can either be used as they are or to generate initial values for the dynamic approximations or iterative methods to find stationary solutions of more complicated models used in, for example, simulation of the slow bacterial dynamics. A comparison with the pseudo analytical steady-state solution by Sáez and Rittmann (1992), which appears to be fairly widespread today, shows that the stationary approximations presented here are more accurate for $\alpha \leq 1$, but far less accurate at high values of α , c.f. 6.1. On the other hand, the methods proposed here also has the advantage of being compatible with the dynamic approximation.

The steady state solutions of the different approximations were compared to the steady state solutions of the FEM method. The stationary solution was calculated for $c_{in}^b = 0.1, 1, 10$ and the values of α and γ presented above. The value of τ does not affect the steady state. The parameter combination with the i^{th} value of α and the j^{th} value of γ got the number $p = 5(i_\alpha - 1) + i_\gamma$.

To find the steady state of the second order approximations ($m=1$), the equations derived in sections 4.1.1 and 4.2.1 were solved for y using the MATLAB function *fsolve*. The FEM solution was then used to get a starting guess for the iteration,

i.e. $y_0 = (c_{in}^b - c_{FEM}^b)/(2\gamma)$ (or in some cases $y_0 = 0.9(c_{in}^b - c_{FEM}^b)/(2\gamma)$). For some parameter combinations this starting guess made the solution converge to a steady state that gave a negative bulk concentration. In these cases $y_0 = 0$ was used as the starting guess instead. For higher order approximations the time derivatives in the state space models were set to zero and the solution of the equations was found using *fsolve* with zero as the starting guess for all states. The tolerance was set to the same value as for the FEM solution, i.e. $1e^{-8}$. The calculated errors are listed in Appendix C for all simulated parameters and approximations.

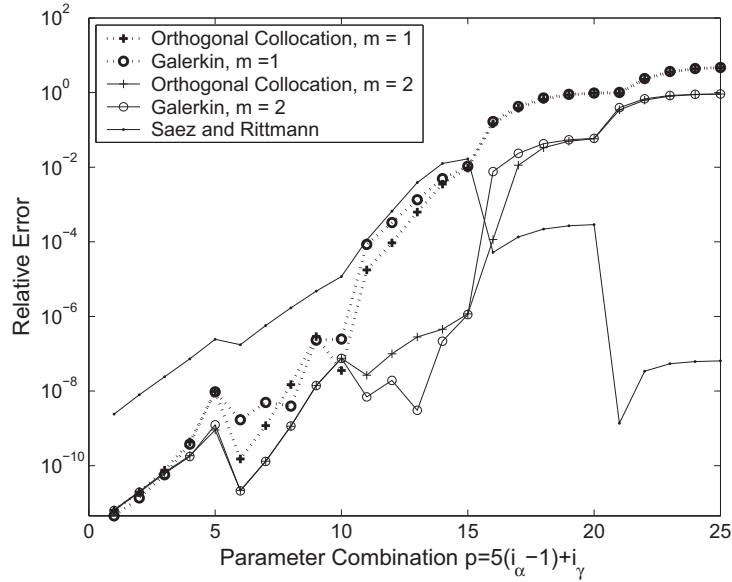

Figure 6.1: Comparison between Sáez & Rittmann and the MWR approximations for $c_{in}^b = 1$.

Figure 6.1 shows the relative error for the second and third order approximations. The simulations showed a significant error for $\alpha > 1$. When $m = 2$ it is nearly 100% for $\alpha = 300$, and when $m = 1$ it is almost 500% for this value of α ! When $\alpha = 30$ the error is more reasonable, but it is still more than 5% for the highest value of γ . It is no surprise that the error increases with α since this is a factor in the nonlinear term in the biofilm equation. A high value of α simply means that the nonlinearity gets more significant. This obviously makes it harder to find a satisfying low order approximation for the model. Increasing γ also increased the relative error for a given α . The parameter dependency for the orthogonal collocation method when $c_{in}^b = 1$ is illustrated in Figure 6.2 with a contour plot. The points at which data is available are marked by a cross. The dependency on α and γ was similar for the Galerkin approximation as can be seen in Appendix D, Figure D.1.

For $\alpha > 1$ the orthogonal collocation method was slightly better than the Galerkin method. For $\alpha = 1$ the Galerkin method was the better one for the third order approximations while the orthogonal collocation method was better for the second order approximations. It is also for this α -value that we see the biggest difference

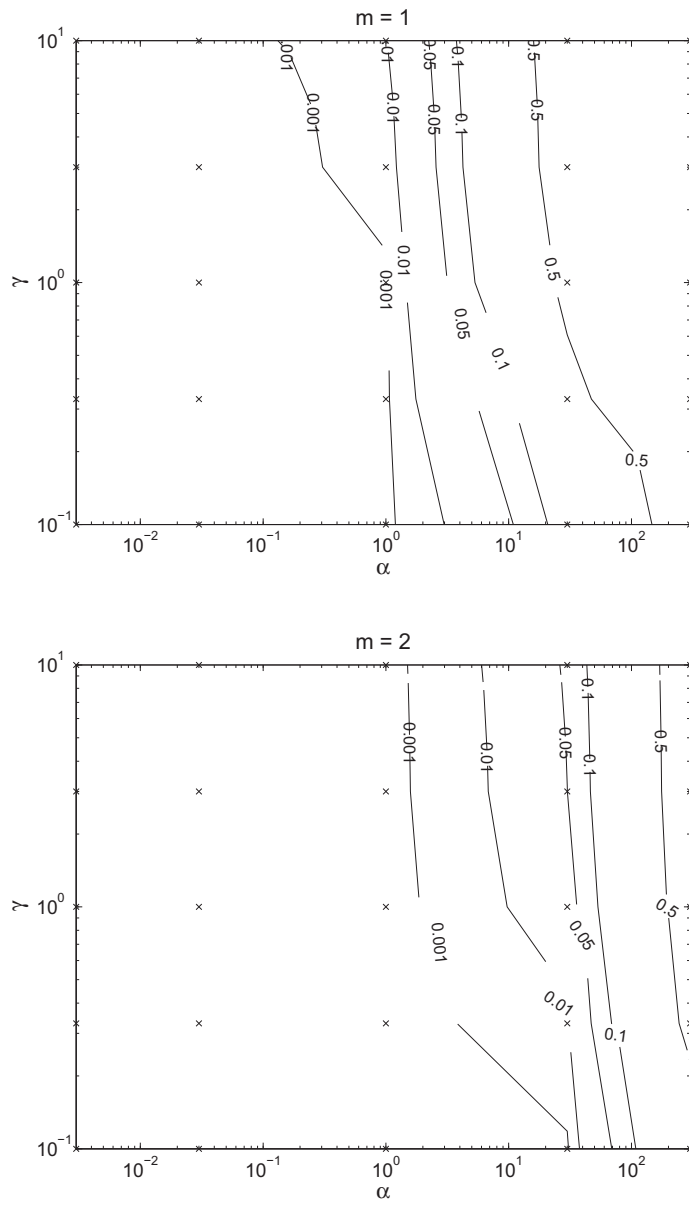

Figure 6.2: *Steady-state error of the orthogonal collocation method when $c_{in}^b = 1$.*

between the different order approximations ($m = 1$ and $m = 2$). For $\alpha < 1$ the error was negligible for both the Galerkin and orthogonal collocation method with $e_{rel} < 10^{-6}$.

Figure 6.3 shows the dependency on the influent concentration for the orthogonal collocation method. The errors decrease when c_{in}^b is increased. The influent concentration dependency for $m = 1$ and for the Galerkin method are similar (see Appendix D, Figures D.2 and D.3).

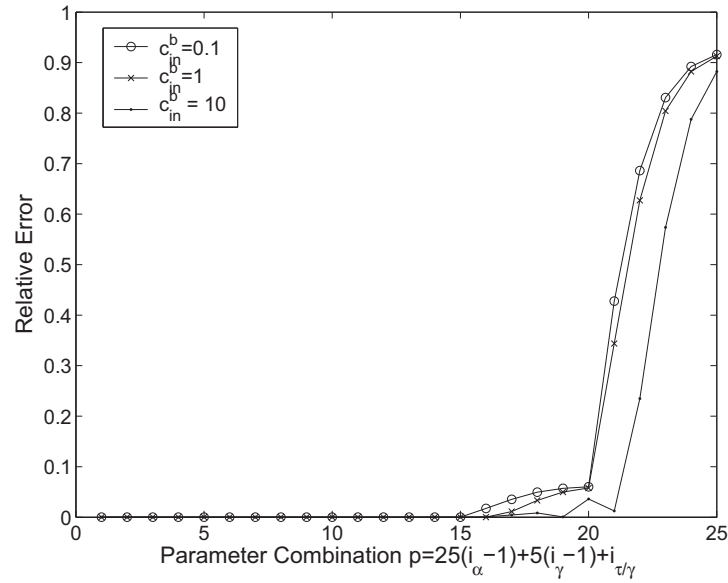

Figure 6.3: *Influent concentration dependency for the orthogonal collocation method ($m = 2$).*

The solution by Sáez and Rittmann is described in Appendix B. It is extremely accurate for the highest simulated values of α . However when $\alpha \leq 1$ the Galerkin and orthogonal collocation approximations gave better results (see Figure 6.1).

Naturally, higher order approximations by the orthogonal collocation method gave smaller errors than the second and third order approximations (see Figure 6.4). However, it takes a seventh order approximation to have the maximum error less than 0.1%, and a sixth order approximation to have a maximum error less than 1%. For $\alpha = 30$ it is more worthwhile to extend the state space model to a higher order. The maximum error for this value of α when $m = 2$ is 0.0578 while for $m = 3$ it is only 0.0014.

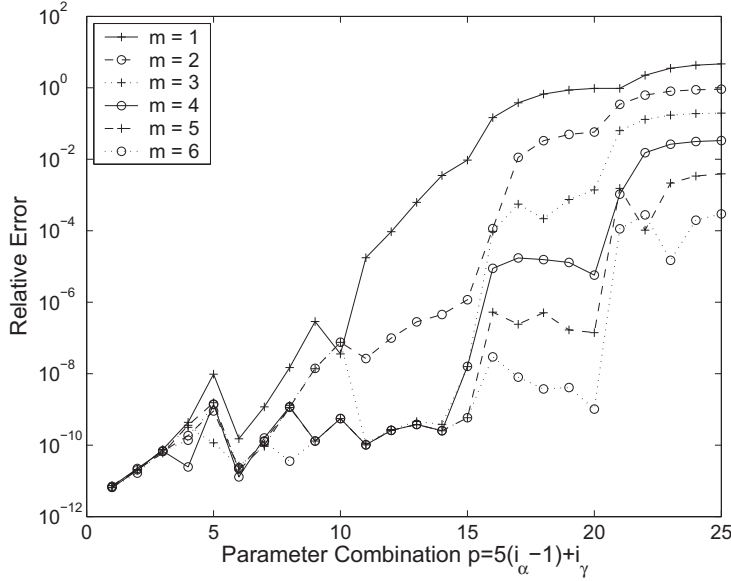

Figure 6.4: *Steady-state error for the orthogonal collocation approximation of different orders.*

6.5 Dynamic Models

The simulations of the approximations were carried out in MATLAB, using one of the built in ODE solvers for stiff differential equations (*ode23s*). The error tolerances were set to the same values as for the FEM simulation. Each parameter combination was given a number $p = 25(i_\alpha - 1) + 5(i_\gamma - 1) + i_{\tau/\gamma}$. The resulting errors are listed in Appendix C for the simulated parameters and the different approximations.

The computation times for the simulations using the approximations are quite small. For example, the simulation time for a simple step response is about a second. This should be compared to the time for the FEM simulation that was about ten minutes on the same computer.

6.5.1 Step Response

Figure 6.5 shows the relative error according to Eq. (6.2) from the step responses for the third order Galerkin approximation and the orthogonal collocation approximation. The results from both approximations are similar. For $\alpha \leq 1$ the Galerkin approximation is slightly better, but the errors of both methods are small and the difference is a consequence of the accuracy of the numerical solution. For $\alpha > 1$ the orthogonal collocation approximation is the better one, and since the errors are higher the difference is more important to consider.

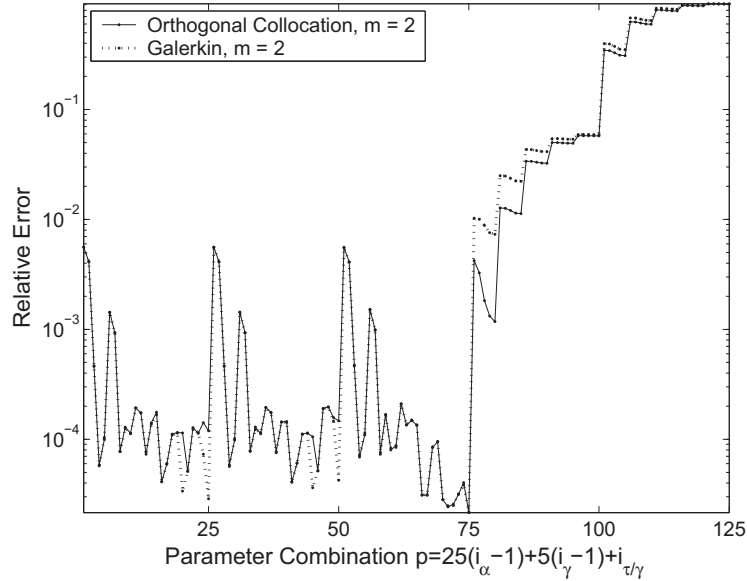

Figure 6.5: *Relative error for unit step responses.*

The large errors for $\alpha > 1$ are expected since the steady state errors are huge for these α -values, and a high value of α implies a more nonlinear model. However, when $\alpha \leq 1$ the error is never more than 1%. If we also require τ not to be less than 0.1, the error is less than 0.1%. Much smaller errors cannot be expected with the tolerances used. Simulations with low values of τ will give larger errors than simulations with high values. The reason is that when τ is small the biofilm concentration has more influence on the bulk concentration and it is in the biofilm that the nonlinearities occur. Figure 6.6 shows how the error depends on the parameters for the orthogonal collocation method. The contour lines in the plots should not be regarded as exact, since the data points are few, but they can be seen as an illustration on how the error changes when the parameters are changed. For example it can be seen that the error increases with γ . It should be kept in mind that the value of γ is different in each plot and hence the same value of τ/γ in two different plots does not correspond to the same value of τ . The points at which data is available are marked by a cross.

The second order approximations are of course not as accurate as the higher order approximations. Especially when $\alpha \geq 1$ the difference is noticeable. For lower values of α the second order approximations are satisfactory for most applications. For larger α the errors are above what can be regarded as a limit for when the approximations are sufficiently accurate, but so is the case for the higher order approximations as well. Again, the lowest values of τ causes large errors. When $\alpha \leq 1$ and $\tau > 0.1$ the maximum error is 1.1%. If we apply the stronger requirements that $\alpha < 1$ and $\tau > 0.33$ the maximum error is 0.1%. Figure 6.7 shows the difference between the orthogonal collocation approximation with $m = 1$ and $m = 2$. There is almost no difference between the Galerkin approximation and the orthogonal collocation approximation when $m = 1$. A plot showing the error of the second

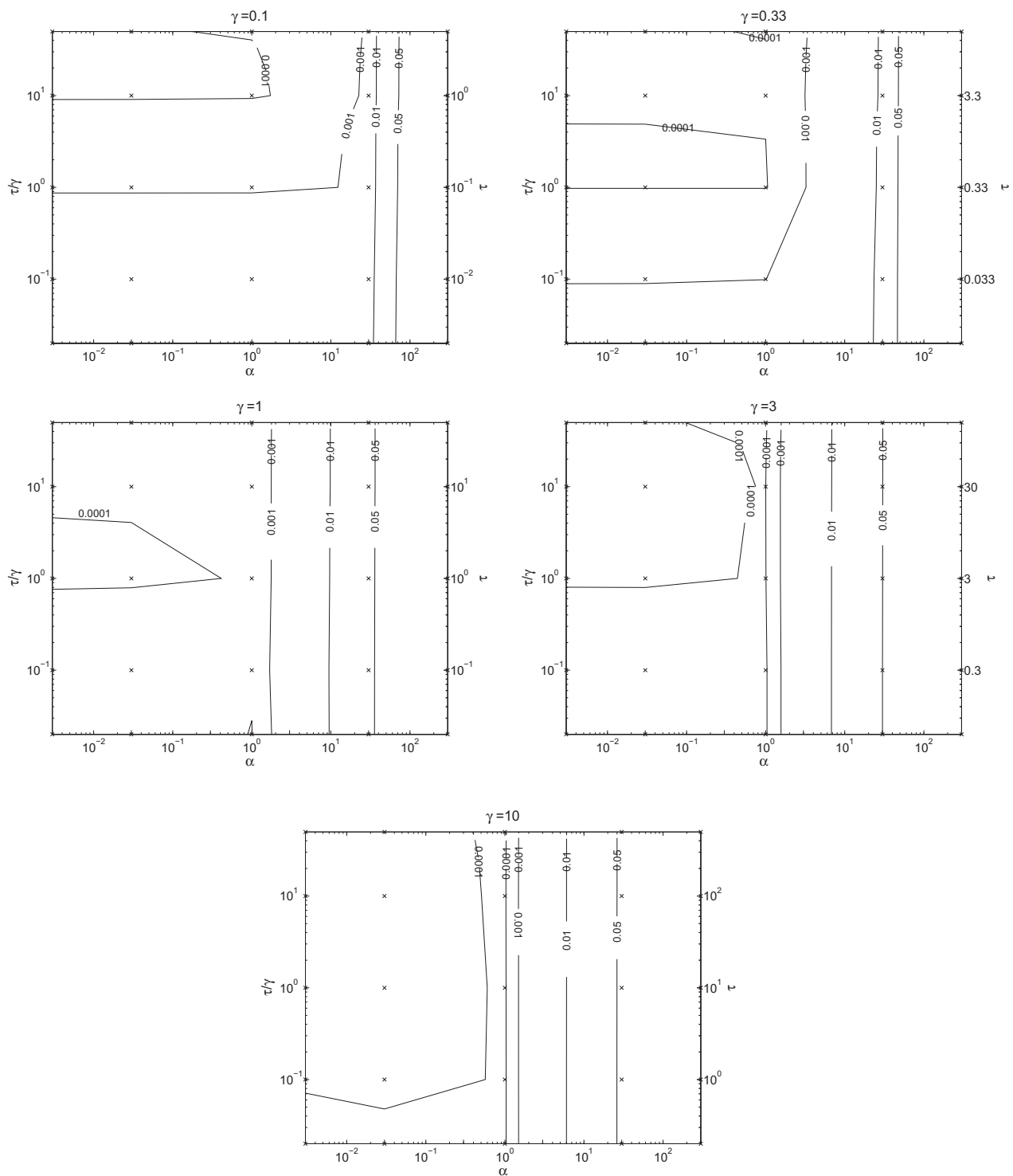

Figure 6.6: Contour plots showing the parameter dependency of the relative error for a step response using the third order orthogonal collocation method.

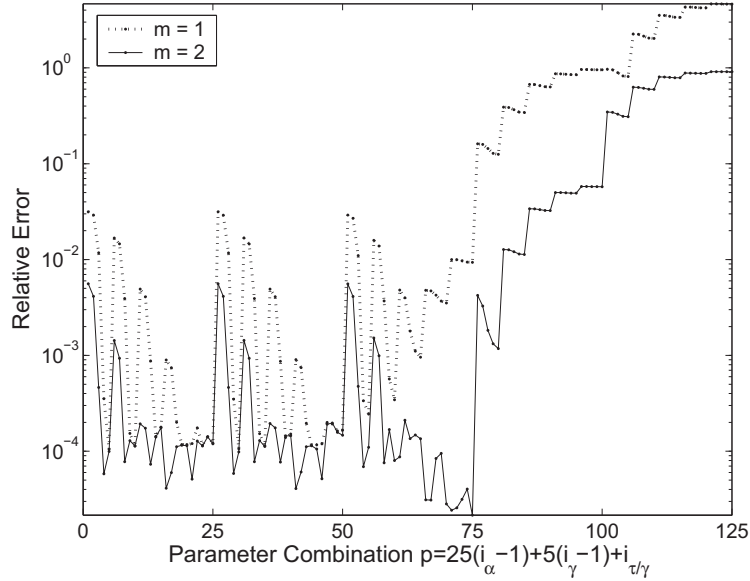

Figure 6.7: *Relative error of the orthogonal collocation method for unit step responses.*

order Galerkin approximation can be found in Appendix D (Figure D.4).

Errors of the higher order orthogonal collocation approximations are shown in Appendix D (Figure D.5). The difference between the different order approximations is particularly significant when $\alpha \geq 1$. When $m = 1$ and $\alpha = 300$ the average error is over 300% while for $m = 6$ and the same value of α the average error is less than 0.02%.

The large errors for high values of α may be a consequence of the approximation gain being inaccurate, but the dynamic behaviour may still be satisfying. To be able to evaluate the dynamic behaviour without the influence of the gain error, the step responses were divided by the steady state concentration at $c_{in}^b = 1$, and a new error was calculated. The results from the simulations where the response is divided by the steady state concentration show that the approximations describe the dynamic behaviour of the system quite well. For $m = 2$, the maximum relative error is 0.032 for the Galerkin method and 0.026 for the orthogonal collocation method. For most parameter combinations the error is significantly smaller. The corresponding numbers for the second order approximation is 0.083 for the Galerkin method and 0.078 for the orthogonal collocation method. Although the maximum error is larger for the Galerkin method, it is difficult to decide which of the Galerkin method and the orthogonal collocation method that is the overall better one. The results are similar for most parameter combinations. See Figure 6.8 for a comparison when $m = 2$. Figure D.6 in Appendix D shows the difference between the Galerkin method and the orthogonal collocation method when $m = 1$. Figure D.7 in the same appendix shows the relative error for the higher order orthogonal collocation

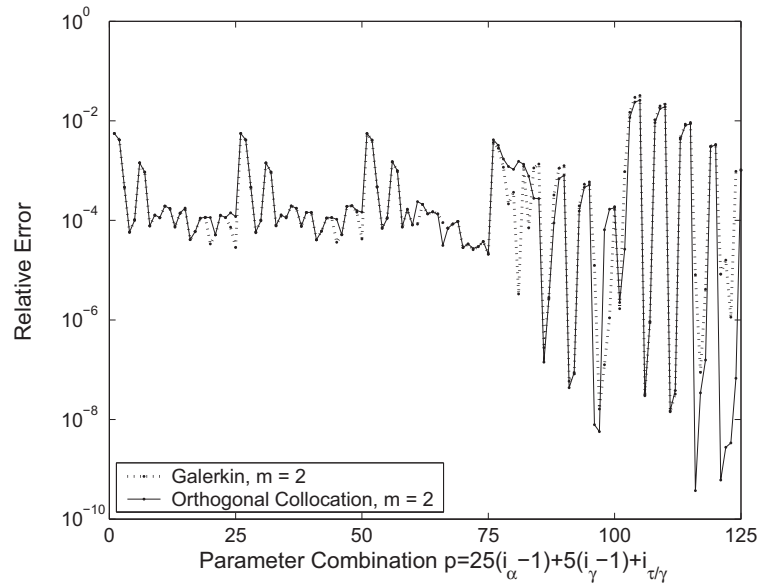

Figure 6.8: Comparison between the Galerkin method and the orthogonal collocation method for unit step responses divided by the stationary gain.

approximations.

Although the gain error is eliminated by dividing the step response with the steady state solution we can see that the largest errors occur when $\alpha = 300$. Except for when $\alpha = 300$ the error is below 1% for all parameter values and both methods. The dependency on τ is somewhat less clear. It seems as when τ/γ and γ are small the error is considerably larger than for high values of the parameters. This means that a low value of τ gives large errors as expected, but when $\alpha = 300$ the situation seems to be reversed. The error is then increasing with τ . Figure 6.9 gives a rough illustration of how the error depends on the different parameters for the orthogonal collocation method in this case. In each figure γ is constant.

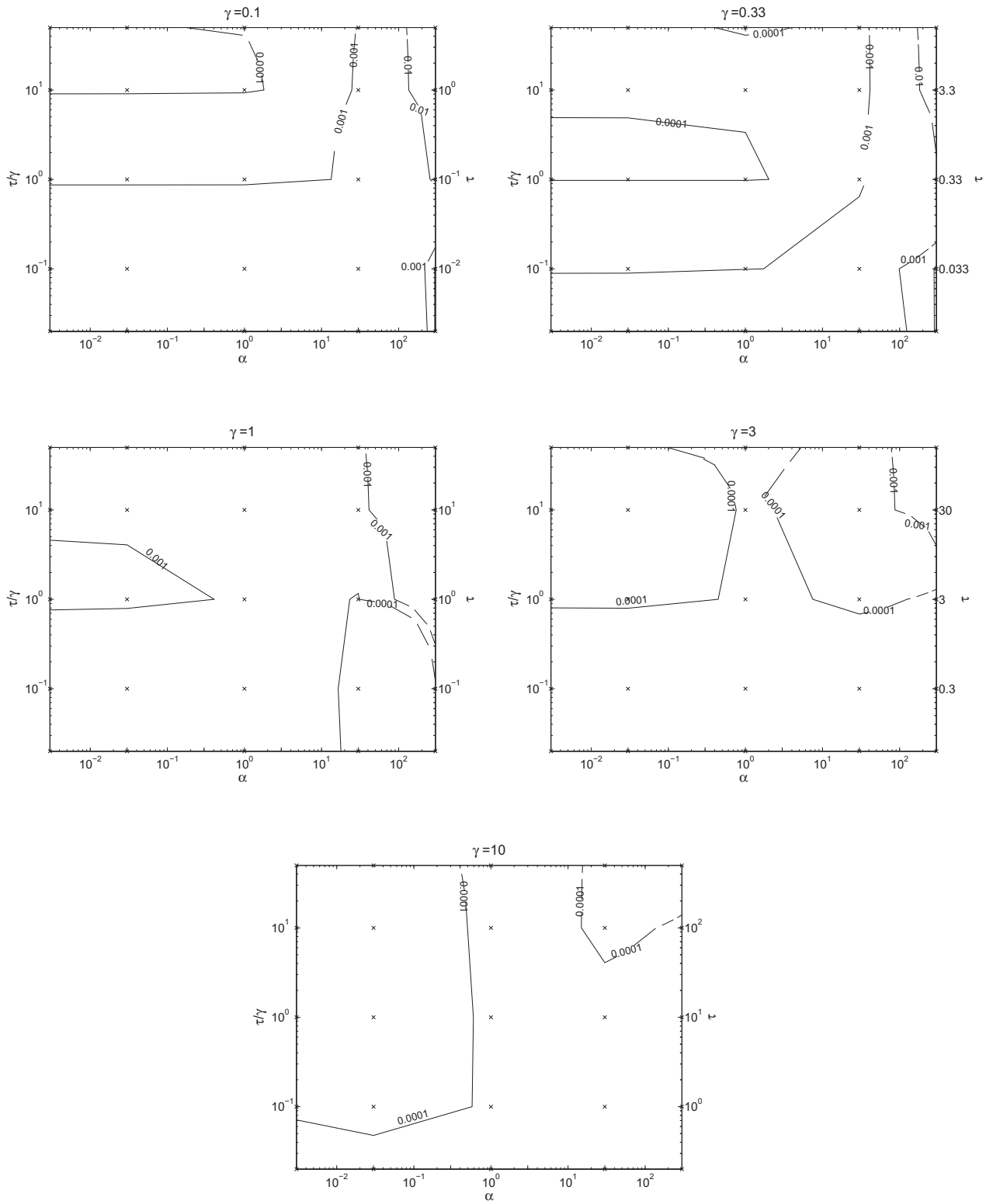

Figure 6.9: Contour plots showing the parameter dependency of the relative error for the third order orthogonal collocation method applied to a step response divided by the stationary concentration.

6.5.2 Impulse Response

The impulse response of a single-input linear state-space model

$$\begin{aligned}\frac{d}{dt}x &= Ax + Bu & x(0) &= 0 \\ y &= Cx\end{aligned}$$

is equivalent to the following unforced response with initial state B .

$$\begin{aligned}\frac{d}{dt}x &= Ax & x(0) &= B \\ y &= Cx\end{aligned}$$

(MathWorks 2002)

The same is true for non-linear systems on the form

$$\begin{aligned}\frac{d}{dt}x &= f(x) + Bu \\ y &= Cx,\end{aligned}$$

where $f(0)$ is limited, which is easily shown by integrating from 0 to t , setting $u = \delta(t)$.

Impulse responses of the approximations were simulated for the parameters chosen above and the errors were estimated by Eq. (6.2). The calculated errors are listed in Appendix C. For some parameter combinations the error of the Galerkin method became enormous as seen in Figure 6.10. The impulse responses for these parameter combinations show that the bulk concentration does not converge to zero but to a large negative value. This value also turns out to be a solution to the steady state model. Hence, the Galerkin approximation has more than one steady state solution for a zero influent concentration and the impulse response simulations show that the physical solution is not globally stable. Depending on the initial conditions the concentration converges to different steady state solutions. The divergence can arise either from the model itself or from the numerical solver. However, decreasing the length of the time step size does not seem to affect the solution.

The initial condition for impulse responses, $x(0) = B$, corresponds to negative concentrations in the biofilm. For $m = 1$

$$\hat{c}(\xi, 0) = x_0(0) + (1.5\xi^2 - 0.5)(\hat{c}^b(0) - x_0(0)) = (1.5\xi^2 - 0.5)\frac{1}{\tau}.$$

For $m = 2$ the minimum concentration when $g_1 < 0$ and $-g_1 < 2g_2$ as in this case, is given by

$$\begin{aligned}c\left(\sqrt{\frac{-g_1}{2g_2}}\right) &= g_0 - 1 - \frac{g_1^2}{4g_2} = \{\text{impulse initial condition}\} = \\ &= 0.375\frac{1}{\tau} - \frac{(3.75\frac{1}{\tau})^2}{17.5\frac{1}{\tau}} \approx -0.428\frac{1}{\tau}.\end{aligned}$$

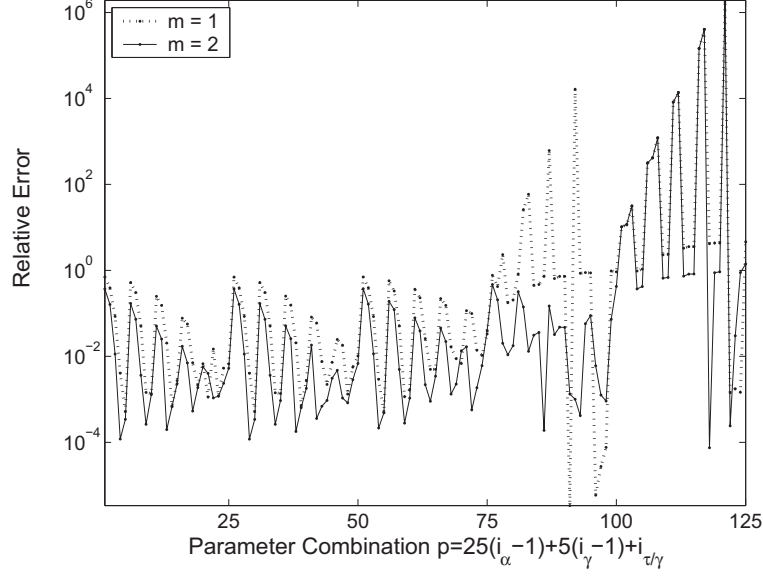

Figure 6.10: *Impulse response error of the Galerkin method.*

Obviously these are non-physical initial conditions. It is important that dynamic solutions that start in the physically acceptable domain remain in that domain. Impulse responses are less important to analyse since they start with a non-physical concentration profile in the biofilm. The problem is that we do not know if this divergence occurs for physical solutions as well.

Some things can be seen however from the impulse simulations. The divergence only occurs for $\alpha > 1$. The dependency on τ is also strong. The solution converges to the wrong steady state only for small τ . By simulation it is shown that the limit is $\tau = 0.5$ when $m = 1$ and $\tau = 3/7$ for $m = 2$. For $m = 1$ this limit corresponds exactly to the limit where $g < 0$ in Eq. (4.8) for impulse initial conditions.

$$\begin{aligned}
 g &= \frac{1 + 1.5x_0 - 0.5\hat{c}^b}{1.5(\hat{c}^b - x_0)} = \{\text{impulse initial condition}\} = \\
 &= \frac{1 - 0.5(1/\tau)}{1.5(1/\tau)} < 0 \Rightarrow \tau < 0.5.
 \end{aligned}$$

For $m = 2$ the limit corresponds to the limit where g_3 in Eq.(4.18) is real, i.e. $g_3^2 > 0$, for impulse initial conditions.

$$\begin{aligned}
 g_3^2 &= g_1^2 - 4g_0g_2 = \{\text{impulse initial condition}\} = \\
 &= \left(-3.75\frac{1}{\tau}\right)^2 - 17.5\left(1 + 0.375\frac{1}{\tau}\right)\left(\frac{1}{\tau}\right) > 0 \Rightarrow \tau < 3/7.
 \end{aligned}$$

In this case $(g_1 - g_3)/(2g_2) < 0$. The conclusion is that the divergence arises when the integral in the last term of Eq. (4.4) contains a singularity. For $m = 1$ this happens when $-1 < g < 0$ and for $m = 2$ when $-1 < (g_1 - g_3)/(2g_2) < 0$ or $-1 < (g_1 + g_3)/(2g_2) < 0$.

The impulse responses for the orthogonal collocation approximation always converge to zero. The error, however, is considerable when α is large or τ is small also for this approximation. For parameter combinations where $\alpha \leq 1$ and $\tau > 0.1$ the maximum error when $m = 2$ is less than 2%. See Figure 6.11 and Figure 6.12. The difference between the second and third order approximations when simulating impulse responses can also be seen in Figure 6.11. As for step responses the largest differences occur for $\alpha > 1$ and for low values of τ , in other words, where the errors are large. The maximum error for the second order approximation is 4.302 compared to 0.877 for the third order approximation. Higher order approximations give better results, but the maximum error is still as high as 0.0596 when $m = 6$ (see Figure D.8 in Appendix D).

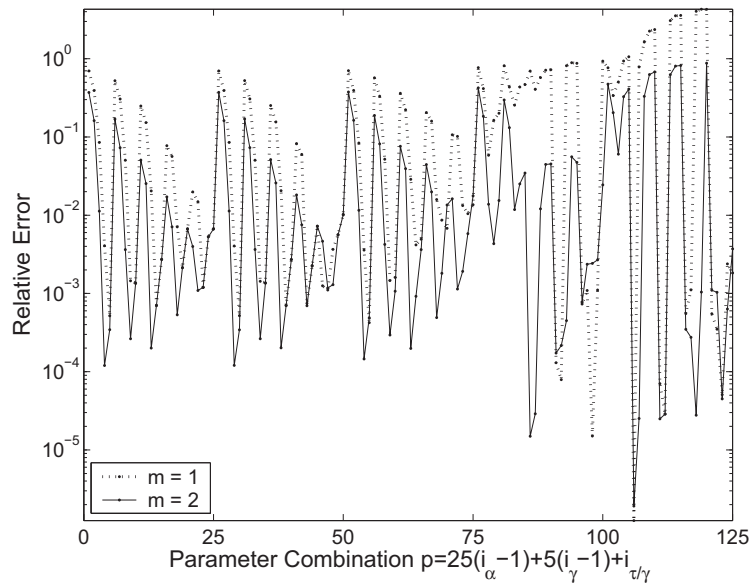

Figure 6.11: *Impulse response error of the orthogonal collocation method.*

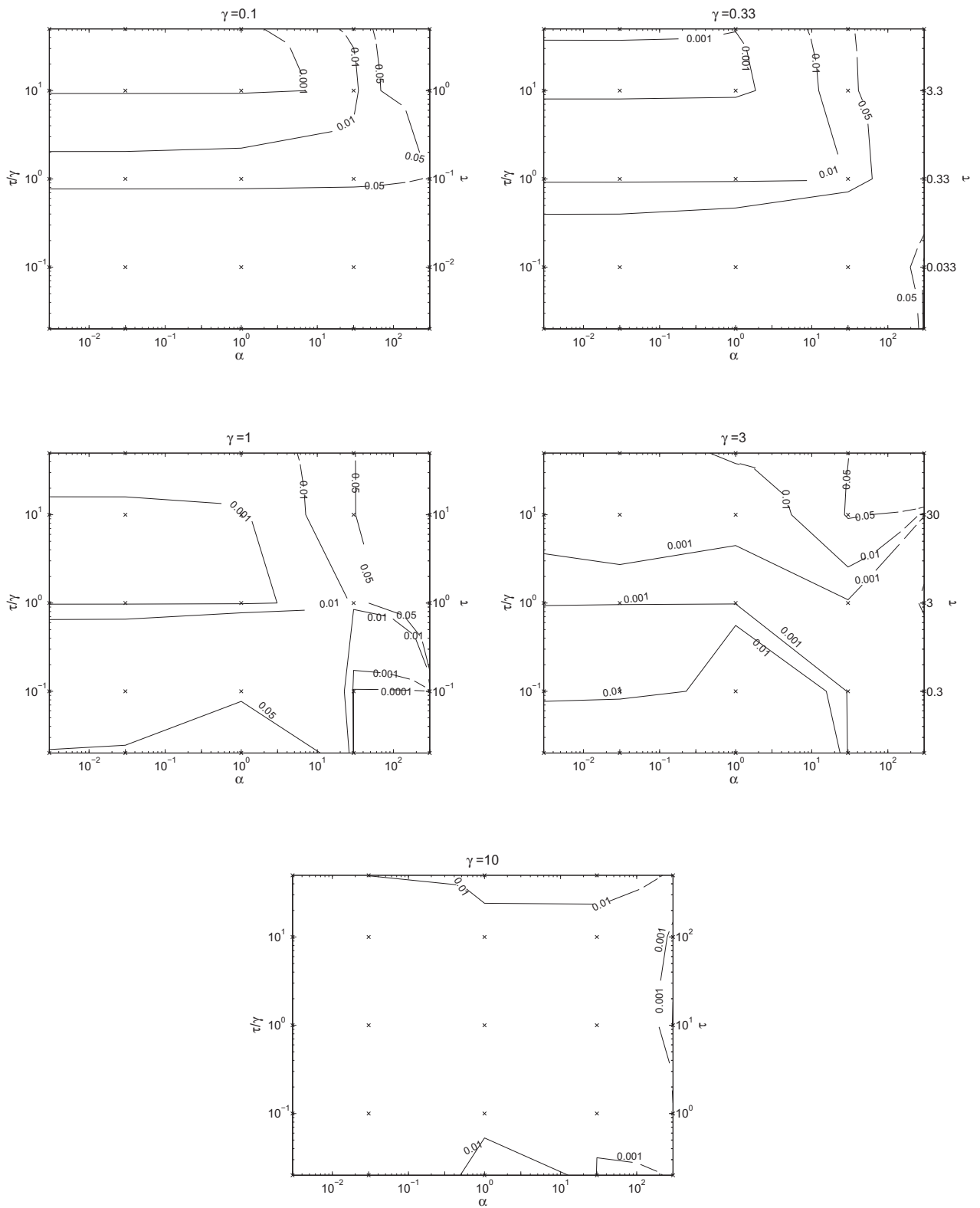

Figure 6.12: Contour plots showing the parameter dependency of the relative error for impulse responses using the third order orthogonal collocation method.

6.5.3 Random Influent Concentration

To evaluate how the system responds to an arbitrary input the response to a low pass filtered random signal was simulated. The random signal was generated as a vector with 1001 elements which were normally distributed with mean 0, and standard deviation $\sigma = 1$, using the MATLAB function *randn*. The signal was run through a first order low pass filter with cutoff frequency $\omega = 10/(\tau_0 + \gamma_0)$ rad/s. The values of τ_0 and γ_0 were chosen in the middle of the intervals of the simulated parameter values, i.e. $\tau_0 = 1$ and $\gamma_0 = 1$. The filter was implemented as a transfer function $G = 1/(1 + s/\omega)$ and the output was generated using the MATLAB function $y_f = \text{lsim}(G, y, t)$, where G is the transfer function, y is the vector of random elements and $t = [0.00 \ 0.01 \ \dots \ 5(\tau_0 + \gamma_0)]$ specifies the time samples used in the simulation. The signal $(t, 1 + y_f)$, which has no negative elements, was used as the input to the system when $\tau = 1$ and $\gamma = 1$. The random signal is shown in Figure 6.13. For other parameter combinations the input was scaled by the characteristic time of the system, $T = \tau + \gamma$, i.e. the same vector y_f was used, but the vector containing the time samples was scaled, such that $t_{scaled} = [0.00 \ 5T/1000 \ \dots \ 5T]$.

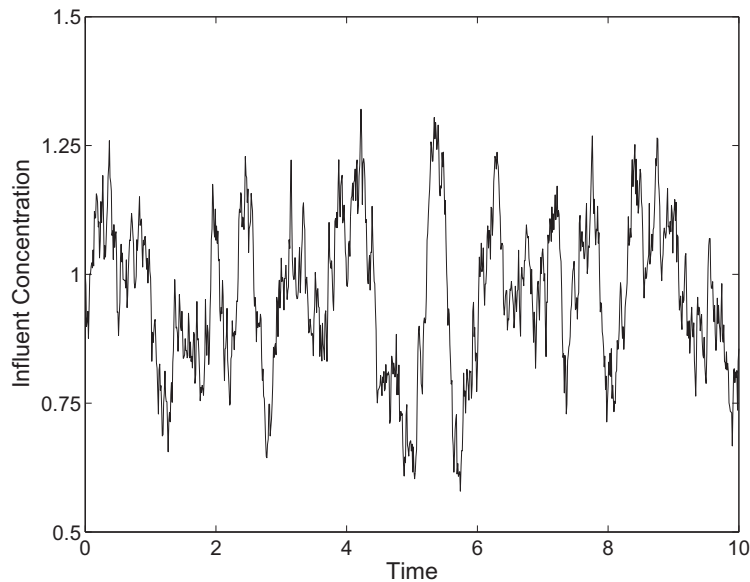

Figure 6.13: *Random input concentration used in simulations.*

Responses of the approximations to this random input, when the initial value was the steady state solution to $c_{in}^b = 1$, were simulated for the parameters chosen in section 6.1 and the error was estimated by Eq. (6.2). The calculated errors are listed in Appendix C. Figure 6.14 shows the relative error for the Galerkin approximation and the orthogonal collocation approximation when $m = 2$. The plot very much resembles that for a step response (see Figure 6.5). The large errors occur for the same parameter combinations and as for the step response the difference between

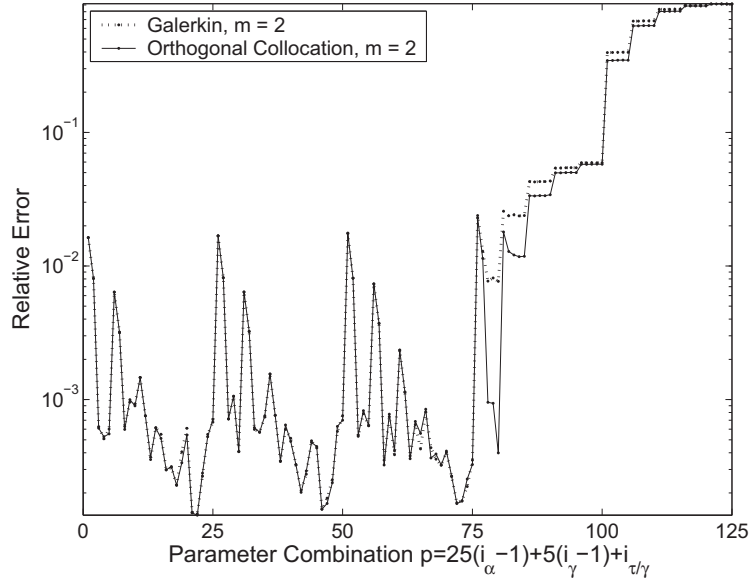

Figure 6.14: *Relative error for the responses to a random input.*

the two methods is minor. Again, the orthogonal collocation method is the better one, where the errors are significant. The difference to the step response is that the errors are up to 30 times larger though for cases when the error is small. This is however mainly not the case for the parameter combinations that give the largest errors, but for the ones that give rather small errors anyway. Figure 6.15 show contour plots of how the error depends on the parameters.

The simulations also show the same relationship between second and third order approximations as for the step response. The biggest differences occur where the errors are large. When $m = 1$ the maximum error for the orthogonal collocation method is 4.671. When $m = 2$ the maximum error is 0.914 (see Figure 6.16). Also for the higher order approximations the largest differences occur where the errors are significant. The error decreases most with an increase in approximation order when $\alpha > 1$. Already for a fifth order approximation the maximum error is less than 5%, which would be accurate enough in many applications considering that the uncertainty in some parameter values may sometimes be up to 50%. The maximum error of the sixth order approximation is as low as 0.5%. Higher accuracy than that should hardly ever be needed. Plots for the Galerkin method and the higher order orthogonal collocation approximations are found in Appendix D (Figure D.9 and D.10).

It is interesting to see that the Galerkin method seems to give no problem of divergence or instability as was the case for the impulse response. This supports the theory that the instabilities that occurred for the impulse response arose because we started with a solution that implied negative concentrations in the biofilm.

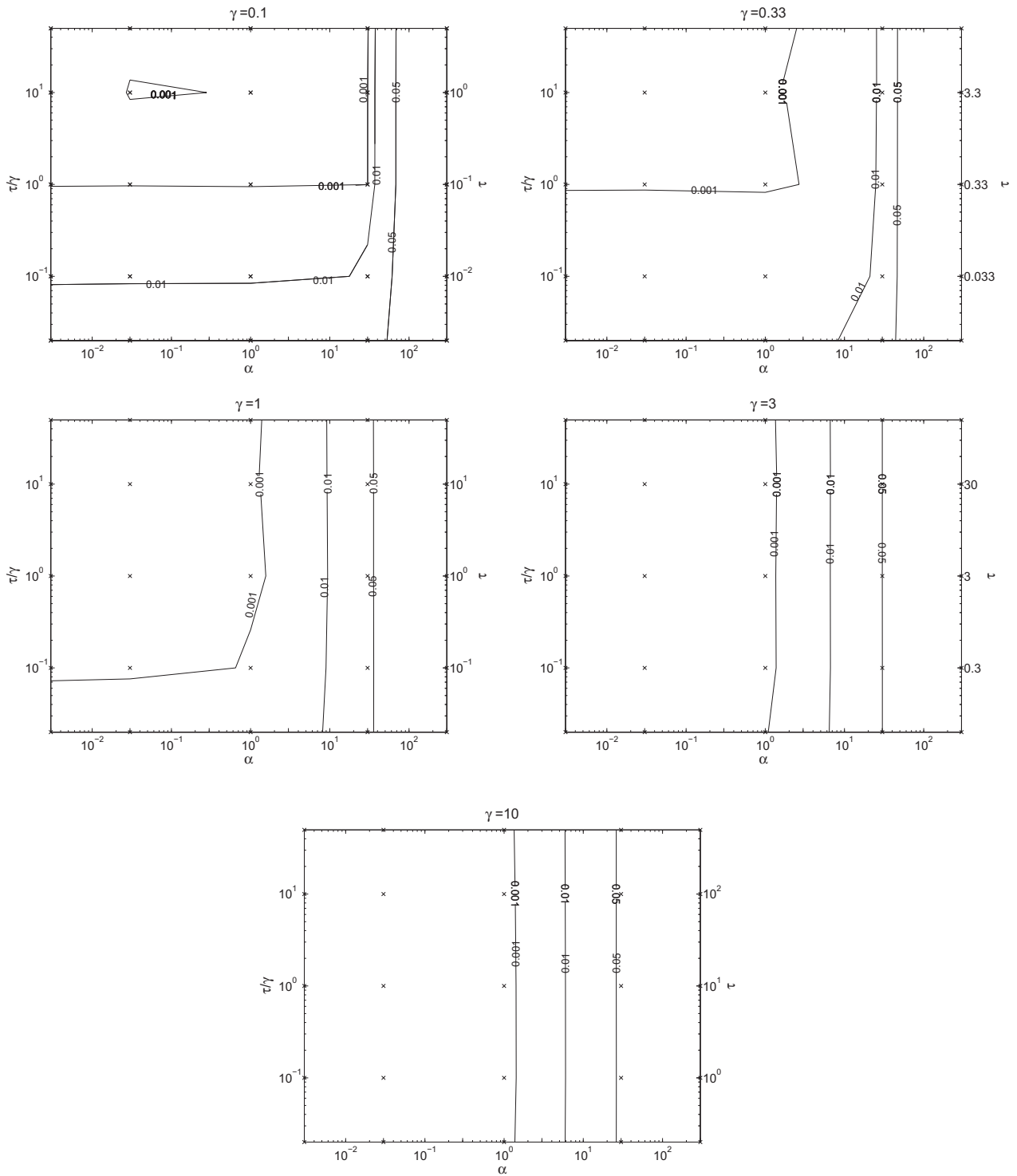

Figure 6.15: Contour plots showing the parameter dependency of the relative error for a random input response using the third order orthogonal collocation method.

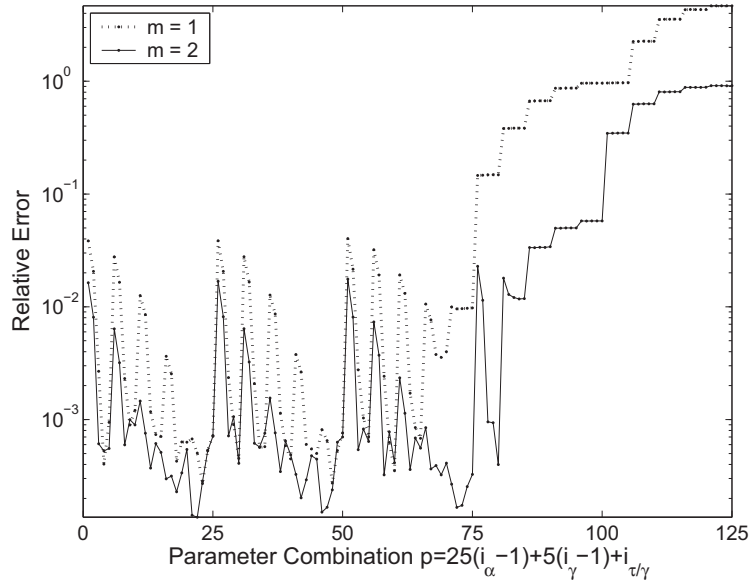

Figure 6.16: *Relative error of the orthogonal collocation method for responses to the random input.*

As already discussed for the step response results, the large errors for high values of α may be a consequence of the approximation gain being inaccurate, while the dynamic behaviour still is satisfying. To be able to evaluate the dynamic behaviour without the influence of the gain error, the responses from the random input were divided by the steady state concentration, and a new error was calculated. The resulting errors can be seen in Figure 6.17. Again, the resemblance to the step responses is striking. The maximum errors are almost the same, 0.028 and 0.029 for the orthogonal collocation approximation and the Galerkin approximation respectively. Figures D.11 and D.12 in Appendix D shows the errors for the second order approximations of the Galerkin method and the orthogonal collocation method and the higher order orthogonal collocation approximations.

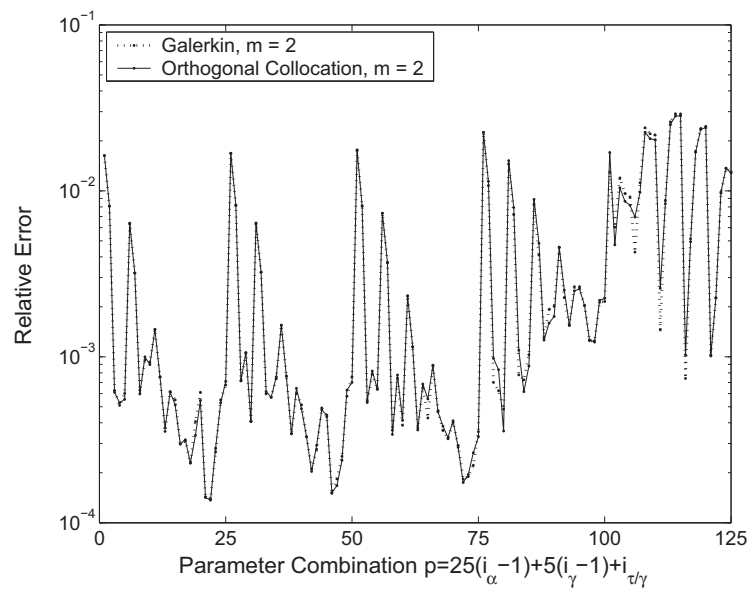

Figure 6.17: *Relative error of the orthogonal collocation method for responses to a random input where the response has been divided by the steady state solution.*

6.5.4 Non-orthogonal Collocation

When the roots of orthogonal polynomials are used as the m collocation points, the collocation method gives exactly the same approximation as the Galerkin method if the integrals have been evaluated by optimal m -point quadrature (Villadsen and Michelsen 1978). This is one reason why the roots of orthogonal polynomials are often used as collocation points. Several comparisons with other MWR methods for different problems have shown that the orthogonal collocation approximation often is the most accurate and reliable collocation method [Finlayson (1972); Villadsen and Michelsen (1978)]. In most of the studied cases however, the purpose is to find an approximation of a single differential equation. In this case we have two coupled equations and we are mainly interested in the bulk concentration which is affected by the biofilm concentrations only by the concentration gradient at the biofilm surface. Hence, it is not obvious that the roots of orthogonal polynomials will be the best choice of collocation points.

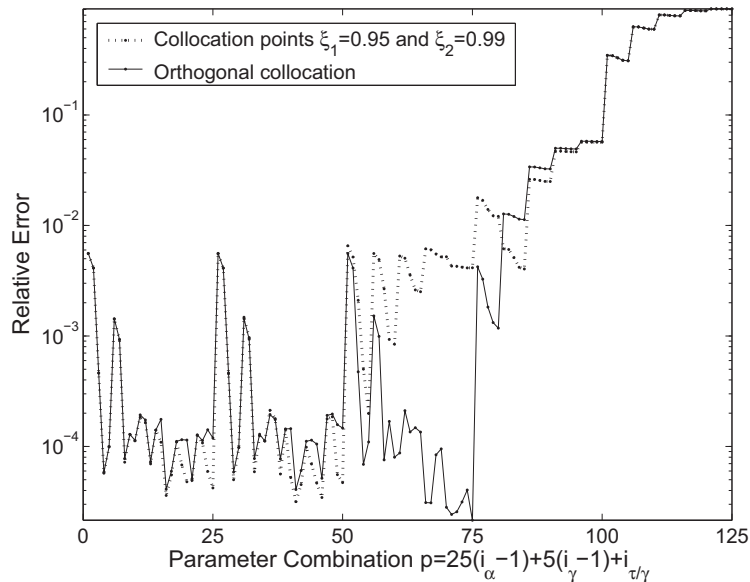

Figure 6.18: *Comparison between the collocation method with collocation points near the biofilm surface and the orthogonal collocation method.*

The second order approximation ($m = 1$) is not depending on the choice of collocation points. For higher order approximations the choice of collocation points may make a significant difference. A possibility is that the concentration gradient at the biofilm surface is best approximated by having collocation points near that surface. This was tested by simulating step responses for $m = 2$ with collocation points $\xi_1 = 0.95$ and $\xi_2 = 0.99$. The orthogonal collocation method ($\xi_1 \approx 0.34$ and $\xi_2 \approx 0.86$) gave significantly better results, especially for $\alpha = 1$, as can be seen in Figure 6.18.

The combination of one collocation point near the surface $\xi_2 = 0.99$ and one in the middle of the biofilm $\xi = 0.5$ gave the result shown in Figure 6.19. Again, the orthogonal collocation method is shown to be better.

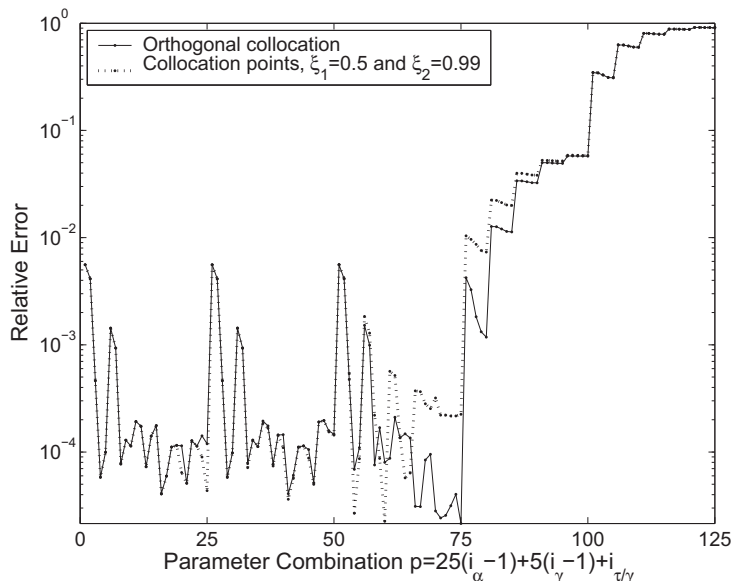

Figure 6.19: Comparison between the orthogonal collocation method and the collocation method with one collocation point near the biofilm surface and one in the middle of the biofilm.

6.5.5 Diffusion Layer on the Biofilm Surface

The simulations that have been analysed so far do not take into account the effects of a boundary layer on the surface of the biofilm. If a boundary layer has developed the boundary condition of the model becomes a Neumann condition instead of a Dirichlet condition and the resulting approximations become somewhat modified (see section 4.4). It is not obvious how this affect the accuracy of the approximations compared to the FEM solution. To get some idea about this, a step response simulation was carried out for two different parameter combinations. In these simulations the models that takes the effect of a liquid boundary layer into account have been used.

The FEM simulation was run in FEMLAB as before. Once again we had to use weak form to solve the system of equations. This time however, the boundary condition was given as a Neumann condition. Unlike the Dirichlet boundary condition this does not result in a term containing the concentration gradient at the surface in the ODE, so this term had to be given explicitly. Except for this change the calculations

were carried out with the same settings as before.

The thickness of the liquid layer, L_w , was supposed to be around half of the total bulk thickness V/A . In Appendix A typical parameter values for some different reactor types are given. For a high rate trickling filter with aerobic growth of autotrophs the bulk thickness is typically equal to the biofilm thickness, $V/A = L$. Hence for this reactor with the assumption about L_w , we have $f_L = L_w/L = 0.5$. The factor $f_D = 0.8$ can also be found in Appendix A. The values of α , γ and τ were chosen among those that have been used in the previous simulations and that are close to the typical values for a high rate trickling filter with aerobic growth of autotrophs. The following parameter combinations were chosen: $p = 53$ where $\alpha = 1$, $\gamma = 0.1$ and $\tau = 0.1$, and $p = 58$ where $\alpha = 1$, $\gamma = 0.33$ and $\tau = 0.33$.

In Table 6.1 the errors for the chosen parameter combinations are shown together with the errors calculated when the effect of the boundary layer was ignored, $L_w = 0$. The result is unambiguous. The errors are at least halved when the effect of the boundary layer is considered. Hence, it is likely that the results derived in the previous sections can be applied in cases where a liquid boundary layer has developed.

Table 6.1: *Influence of a Liquid Boundary Layer on the Relative Error of a Step Response*

	<i>Orthogonal Collocation</i>		<i>Galerkin</i>	
	$m = 1$	$m = 2$	$m = 1$	$m = 2$
$p = 53$				
$L_w = 0.5L$	0.0032	9.30E-05	0.0031	8.96E-05
$L_w = 0$	0.0110	4.75E-04	0.0104	4.62E-04
$p = 58$				
$L_w = 0.5L$	0.0017	3.80E-05	0.0016	3.69E-05
$L_w = 0$	0.0037	7.57E-05	0.0033	7.31E-05

Chapter 7

CONCLUSION

Two different approximations describing the fast dynamics of continuously stirred biofilm reactors have been derived. Standard assumptions have been made for the biofilm and Monod kinetics are used to describe the reaction rate. The approximations have been derived using two common MWR methods, the Galerkin method and the orthogonal collocation method. To evaluate the approximations they were compared to a solution by the FEM method.

For the second and third order orthogonal collocation method and for the second order Galerkin method it has been shown that there is a unique steady state in a domain containing the domain where we expect the solution to be. This stationary solution can be found by solving one single equation. For the second order orthogonal collocation method it has been shown that for zero influent concentration the solution converge to zero concentrations if the initial solution is physically acceptable.

A comparison with the pseudoanalytical steady state solution by Sáez and Rittmann (1992) shows that the approximations derived here are more accurate for $\alpha \leq 1$ but less accurate for higher values of α . However, the approximations derived here has the advantage of being compatible with the dynamic solution.

Simulations of step responses, impulse responses and responses to a random influent concentration show that a second order state space model is enough to describe systems with low reaction rates and large bulk volume compared to the biofilm liquid volume. This means that the PDE and the ODE is replaced by only two ODEs. However, for high α -values (high reaction rates) or low values of τ (bulk volume small compared to biofilm liquid volume) the second order approximations are not accurate enough. For high values of α it is mainly the stationary gain that is unaccurate.

A third order state space model is naturally better than the lower order models,

but it shows the same dependency on the parameters. For high values of α and low values of τ the error grows very large. Which order approximation one should use is, of course, a matter of how accurate one needs the solution to be. Appendix C contains tables with errors for all the simulated parameter combinations and inputs. In these tables the error for a specific parameter combination can be looked up and then it can be decided if, for example, the second order approximation is good enough. The results from the step response and the random input are very similar and the difference is mainly that the errors of the step response are somewhat lower. While the maximum error of the seventh order approximation for the random input response is only 0.2%, it is as high as 6% for the impulse response. However, since the impulse initial conditions in the approximations imply negative concentrations in the biofilm, there are reasons to question the results from the simulated responses, or at least not put too much weight on the exact numbers. Hence, the results from the random input response should be the best guideline. For the fifth order orthogonal collocation approximation the maximum error of the random input response is less than 5%, which would be accurate enough in many cases. The maximum error of the sixth order approximation is as low as 0.5% and an approximation of that order should be sufficient in almost any application.

If $\alpha \gg 1$ the stationary gain error may be very large (several hundred per cent). If this is the case, and a low order approximation is desired, it is probably best to calculate the steady state solution for the actual operating point by some other method, e.g. the pseudoanalytical solution by Sáez and Rittmann (1992) and correct the state space model by this stationary solution. The linearized model around that operating point can then be used in calculations. Simulations of step responses and random input responses divided by the stationary gain give a maximum error of about 3% for the third order approximations and 8% for the second order approximations.

Appendix A lists typical values of the parameters for different types of reactors and biofilms. For reactors with aerobic growth of autotrophs, $\alpha < 1$ and $\tau > 0.1$, meaning that the high values of α and very low values of τ will not occur for this kind of biofilm. Hence, one conclusion is that the low order approximations are fine for reactors with aerobic growth of autotrophs. If the reactor is a moving bed bio reactor $\tau > 100$ by which the conclusion can be drawn that for this kind of reactor the approximations are really good.

The simulations show almost no difference in accuracy between the Galerkin and the orthogonal collocation approximations. The orthogonal collocation method however seems to be slightly better, and also has the advantage of being very easy to expand to higher orders. Moreover, the orthogonal collocation method, unlike the Galerkin method, gives simple state space model expressions where the same expression is true for all state values. Finally, the Galerkin approximation has shown some instability tendencies, admittedly only when the initial solution implied negative concentrations, but this may still be a problem. This problem has not been observed for the orthogonal collocation method. To sum up, the orthogonal collocation approxima-

tion has some minor advantages compared to the Galerkin approximation, but any of them could be used for the right parameter combinations.

Simulations were also carried out to compare the orthogonal collocation method with a collocation method using other collocation points. This comparison showed that the orthogonal collocation method in most cases was the better one. Finally, the influence of a liquid boundary layer on the surface of the biofilm was studied. The evaluation clearly showed that the approximations where this boundary layer was taken into account was better compared to a FEM solution than the approximations where the boundary layer had been ignored.

Bibliography

- Andersson, B., Aspegren, H., Parker, D. S. and Lutz, M. P. (1994). High rate nitrifying trickling filters. *Wat. Sci. Tech.*, **29**(10-11), 47–52.
- Boller, M., Tschui, M. and Gujer, W. (1997). Effects on transient nutrient concentrations in tertiary biofilm reactors. *Wat. Sci. Tech.*, **36**(1), 101–109.
- Comsol (2003). mail contact, FEMLAB Applications support.
- Finlayson, B. A. (1972). *The Method of Weighted Residuals and Variational Principles*. Academic Press, New York.
- Gujer, W. and Boller, M. (1986). Design of a nitrifying tertiary trickling filter based on theoretical concepts. *Wat. Res.*, **20**(11), 1353–1362.
- Gujer, W. and Wanner, O. (1990). Modelling mixed population biofilms. In: *Biofilms*, W. G. Characklis and K. C. Marshall (Eds.). Wiley, New York. pp 397–443.
- Kissel, J. C., McCarty, P.L. and Street, R. L. (1984). Numerical simulation of mixed culture biofilm. *J. Environ. Eng.*, **110**(2), 393–411.
- MathWorks (2002). *MATLAB Control System Toolbox, Reference*. The MathWorks Inc.. 3 Apple Hill Drive, Natick, MA, USA.
- Rittmann, B. E. (1985). The effect of load fluctuations on the effluent concentration produced by fixed-film reactors. *Wat. Sci. Tech.*, **17**, 45–52.
- Rittmann, B. E. and McCarty, P. L. (1980). Model of steady-state-biofilm kinetics. *Biotechnol. Bioeng.*, **22**, 2343–2357.
- Sáez, P. B. and Rittmann, B. E. (1992). Accurate pseudoanalytical solution for steady-state biofilms. *Biotechnol. Bioeng.*, **39**, 790–793.
- Villadsen, J. and Michelsen, M. L. (1978). *Solution of Differential Equation Models by Polynomial Approximation*. Prentice-Hall. Englewood Cliffs, New Jersey.
- Wik, T. (1999a). On modeling the dynamics of fixed biofilm reactors - with focus on nitrifying trickling filters. PhD thesis. Chalmers University of Technology. SE-412 96 Göteborg, Sweden. ISBN 91-7197-797-X.

- Wik, T. (1999*b*). Rational transfer function models for nitrifying trickling filters. *Wat. Sci. Tech.*, **39**(4), 121–128.
- Wik, T. and Breitholtz, C. (1996). Steady-state solution of a two-species biofilm problem. *Biotechnol. Bioeng.*, **50**(6), 675–686.
- Wik, T. and Breitholtz, C. (1998). Rational transfer function models for biofilm reactors. *AIChE J.*, **44**(12), 2647–2657.

Appendix A

Parameters

To calculate the values of α the following relations were used.

$$\alpha = (-\nu) \frac{L^2 \mu_m X}{K_s D Y},$$

where $D = f_D D^b$ and ν is the stoichiometric coefficient. In steady-state the mass flux into the biofilm can be written as (Gujer and Boller 1986)

$$J = \sqrt{\frac{2DX\mu_m}{Y} (c^b - c(0) - K_s \ln \left(\frac{K_s + c^b}{K_s + c(0)} \right))}.$$

If the amount of bacteria is large $c(0) \approx 0$. For $\nu = -1$, α can then be estimated as

$$\alpha = \frac{J_{max}^2 L^2}{2D^2 K_s (c^b \ln(1 - c^b/K_s))},$$

where c^b is the bulk concentration at which J_{max} occurs. α for the other substrates is given by

$$\alpha_j = (-\nu_j) \frac{K_s D}{K_{s,j} D_j} \alpha.$$

The parameters γ and τ varies with different types of reactors. The following relations were used to calculate estimates of their values.

Trickling Filters:

$$\begin{aligned} \gamma &= \frac{AD}{QL} = \frac{hD}{q_A L} \\ \tau &= \frac{V}{AL\epsilon} \gamma = \frac{L^b}{L\epsilon} \gamma \end{aligned}$$

where h is the mixing height, q_A is the hydraulic load and $L_b = V/A$.

Moving Beds:

$$\gamma = \frac{AD}{QL} = \frac{a}{1/\rho - \Delta V - aL} HRT \frac{D}{L}$$

$$\tau = \frac{V}{AL\epsilon} \gamma = \frac{1/\rho - \Delta V - aL}{aL\epsilon} \gamma$$

where a is the specific surface area of the carriers, ρ is the degree of filling, ΔV is the water displacement and $HRT = V/Q$ is the hydraulic retention time.

The following tables list values of the parameters needed to calculate α, γ and τ . The first table gives values that are needed to calculate stoichiometric coefficients and diffusion constants for different substrates.

Table A.1: *Constant Parameters*

Y_A	gCOD/gN	0.24
Y_{NO}	gCOD/gN	0.04
Y_H	gCOD/gCOD	0.6
$f_D = D/D^b$		0.8

Table A.2: *Biofilm Parameters*

		<i>Aerobic growth autotrophs</i>				<i>Aerobic growth heterotrophs</i>		<i>Anoxic growth heterotrophs</i>	
		NH ₄	O ₂	Alk	NO ₂	COD	O ₂	COD	NO _x
K	g/m ³	1.00	0.50	0.50	0.40	20.00	0.40	20.00	0.50
D^b	cm ² /d	1.48	1.74	0.91	1.33	0.83	1.74	0.83	1.33
D	cm ² /d	1.18	1.39	0.73	1.06	0.66	1.39	0.66	1.06
J_{max}	g/(m ² d)	1.50			1.0	15.00		12.0	
c^b	g/m ³	20			1.0	100.0		100.0	
$-\nu$		1.00	4.33	0.14	1.00	1.00	0.40	1.00	0.14

Table A.3: *Reactor Parameters*

		<i>Aerobic growth autotrophs</i>	<i>Aerobic growth heterotrophs</i>	<i>Anoxic growth heterotrophs</i>
<i>High Rate Trickling Filters</i>				
ϵ	m ³ /m ³	0.50	0.60	0.60
L	mm	0.30	2.00	2.00
$L^b = \frac{V}{A}$	mm	0.30	0.30	0.30
q_A	m/d	0.80	0.80	0.80
h	m	0.50	0.50	0.50
<i>Moving Bed Bioreactors</i>				
$HRT = \frac{V}{Q}$	d	0.02	0.02	0.02
a	m ² /m ³	500	300	300
ρ	m ³ /m ³	0.70	0.70	0.70
ΔV	m ³ /m ³	0.18	0.18	0.18
L	mm	0.10	1.50	1.50
ϵ	m ³ /m ³	0.50	0.65	0.65

Table A.4: *Model Parameters*

	<i>Aerobic growth autotrophs</i>				<i>Aerobic growth heterotrophs</i>		<i>Anoxic growth heterotrophs</i>	
	NH ₄	O ₂	Alk	NO ₂	COD	O ₂	COD	NO _X
<i>High Rate Trickling Filters</i>								
α	0.12	0.87	0.06	0.33	28	272	18	64
γ	0.25	0.29	0.15	0.22	0.14	0.29	0.14	0.22
τ	0.49	0.58	0.30	0.44	0.03	0.07	0.03	0.06
$\frac{\tau}{\gamma}$	2.00	2.00	2.00	2.00	0.25	0.25	0.25	0.25
<i>Moving Bed Bioreactors</i>								
α	0.01	0.10	0.006	0.04	16	153	10	36
γ	10	12	6	9	0.35	0.73	0.35	0.56
τ	493	580	303	443	0.95	1.98	0.95	1.52
$\frac{\tau}{\gamma}$	48	48	48	48	2.7	2.7	2.7	2.7

Appendix B

Pseudoanalytical solution by Sáez and Rittmann

The accurate pseudoanalytical solution proposed by Sáez and Rittmann (1992) is based on the following equations where J^* is the scaled actual flux of substrate into the biofilm and J_{deep}^* is the scaled flux into a deep biofilm. c_{min}^b is the scaled minimum bulk substrate concentration that can support a steady-state biofilm.

$$J^* = f J_{deep}^* \quad (\text{B.1})$$

$$J_{deep}^* = \sqrt{2(c^b - \ln(1 + c^b))} \quad (\text{B.2})$$

$$f = \tanh \left[p \left(\frac{c^b}{c_{min}^b} - 1 \right)^q \right], \quad (\text{B.3})$$

where

$$\begin{aligned} p &= 1.5557 - 0.4117 \tanh(\ln(c_{min}^b)) \\ q &= 0.5035 - 0.0257 \tanh(\ln(c_{min}^b)). \end{aligned}$$

The flux is scaled as $J^* = \tilde{J}L/(K_s D \sqrt{\alpha})$ where $\tilde{\cdot}$ denotes an unscaled variable. The concentration is scaled as usual ($c^b = \tilde{c}^b/K_s$).

c_{min}^b depends on the maintenance-respiration coefficient b .

$$c_{min}^b = \frac{b}{\mu_m - b} \quad (\text{B.4})$$

The parameter b is not explicitly implemented in the approximations developed here, but the steady-state biofilm thickness L is a function of b .

$$L = \frac{\tilde{J}Y}{bX} \quad (\text{B.5})$$

From Eq. (3.1) we get that

$$\tilde{J} = D \frac{d\tilde{c}}{d\xi} \Big|_{\tilde{\xi}=L} = \frac{Q}{A} (\tilde{c}_{in}^b - \tilde{c}^b) = \frac{QK_s}{A} (c_{in}^b - c^b). \quad (\text{B.6})$$

Combining the above equation and Eq. (B.5) we get an expression for b that can be used in (B.4) to calculate c_{min}^b for a given c^b .

$$b = \frac{QK_s}{A}(c_{in}^b - c^b) \frac{Y}{LX} = \frac{\mu_m}{\alpha\gamma}(c_{in}^b - c^b)$$

$$c_{min}^b = \frac{\frac{\mu_m}{\alpha\gamma}(c_{in}^b - c^b)}{\mu_m - \frac{\mu_m}{\alpha\gamma}(c_{in}^b - c^b)} = \frac{c_{in}^b - c^b}{\alpha\gamma - (c_{in}^b - c^b)}$$

Now that we have an expression for c_{min}^b we can calculate p, q, f and J^* from Eqns. (B.1)-(B.3). For the steady-state bulk concentration this flux, when unscaled, should be the same as the flux calculated from Eq.(B.6). This way c^b can be found in an iterative manner.

Expressed in terms of α and γ the problem is to find the zero of the function

$$f(c^b) = c_{in}^b - c^b - \gamma\sqrt{\alpha}J^*,$$

where J^* is calculated from Eqns. (B.1)-(B.3).

Appendix C

Tables of Approximation Errors

The tables in this appendix lists the relative errors calculated for all simulated parameters, inputs and the different approximations.

The different approximations are the second and third order Galerkin approximations and the second to seventh order orthogonal collocation approximations. They are all derived in Chapter 4.

Errors have been calculated for steady state solutions as well as step responses, impulse responses and responses to random inputs. For the step responses and random input responses the solution has also been divided by the steady state solution before the error has been calculated.

Simulations were carried out for five different values of each of the parameters α , γ and τ/γ . All combinations of

$$\begin{aligned}\alpha &= 0.003, 0.03, 1, 30, 300; \\ \gamma &= 0.1, 0.33, 1, 3, 10; \\ \tau/\gamma &= 0.02, 0.1, 1, 10, 50\end{aligned}$$

gave a total of 125 parameter combinations. Each combination were assigned a number p . The combination of the i_α^{th} α -value, the i_γ^{th} γ -value and the $i_{\tau/\gamma}^{th}$ value of τ/γ got the number $p = 25(i_\alpha - 1) + 5(i_\gamma - 1) + i_{\tau/\gamma}$.

For the steady-state solutions the value of τ has no importance. Hence, only 25 parameter combinations were used. Here, the combination $p = 5(i_\alpha - 1) + i_\gamma$ consisted of the i_α^{th} α -value and the i_γ^{th} γ -value.

Steady State

Table C.1: *Orthogonal Collocation (m=1) - Steady State*

$c_{in}^b = 0.1$		$c_{in}^b = 1$		$c_{in}^b = 10$	
p	Error	p	Error	p	Error
1	2.6913E-11	1	6.3925E-12	1	5.6657E-12
2	8.9638E-11	2	1.9751E-11	2	1.7201E-11
3	2.5016E-10	3	7.5653E-11	3	5.9999E-11
4	2.6993E-10	4	4.3421E-10	4	1.8244E-10
5	1.4355E-08	5	9.7072E-09	5	6.2979E-10
6	3.2702E-08	6	1.5097E-10	6	9.5242E-12
7	1.0634E-07	7	1.1809E-09	7	3.2701E-11
8	2.9924E-07	8	1.4851E-08	8	1.2066E-10
9	4.7654E-07	9	2.8912E-07	9	8.5862E-10
10	9.0335E-06	10	3.5624E-08	10	2.0561E-08
11	0.0007549	11	1.7609E-05	11	1.3623E-07
12	0.0022782	12	9.4089E-05	12	4.8271E-07
13	0.0054376	13	0.00062369	13	1.8079E-06
14	0.0097176	14	0.0035252	14	1.0615E-05
15	0.013184	15	0.0095102	15	0.00029296
16	0.20722	16	0.14624	16	0.0042083
17	0.46674	17	0.38083	17	0.033701
18	0.73049	18	0.66827	18	0.25869
19	0.89517	19	0.86624	19	0.61762
20	0.97148	20	0.96161	20	0.86735
21	1.0903	21	0.96321	21	0.42993
22	2.3772	22	2.2544	22	1.4223
23	3.6065	23	3.5363	23	2.9259
24	4.3405	24	4.311	24	4.0297
25	4.6728	25	4.6631	25	4.5677

Table C.2: *Orthogonal Collocation (m=2) - Steady State*

$c_{in}^b = 0.1$		$c_{in}^b = 1$		$c_{in}^b = 10$	
p	Error	p	Error	p	Error
1	6.6173E-12	1	6.5822E-12	1	4.8965E-12
2	2.1595E-11	2	2.034E-11	2	1.7622E-11
3	8.5206E-11	3	6.662E-11	3	6.1758E-11
4	6.8526E-10	4	1.8528E-10	4	1.7825E-10
5	1.5784E-08	5	9.058E-10	5	5.7872E-10
6	3.3016E-10	6	2.1657E-11	6	5.605E-12
7	2.2985E-09	7	1.3142E-10	7	1.4462E-11
8	2.4388E-08	8	1.1409E-09	8	5.3644E-11
9	3.3828E-07	9	1.4042E-08	9	1.6828E-10
10	4.0287E-10	10	7.5839E-08	10	1.62E-09
11	3.3288E-08	11	2.6532E-08	11	2.7905E-10
12	7.6272E-09	12	9.9475E-08	12	2.1988E-09
13	4.6618E-07	13	2.8212E-07	13	7.879E-12
14	2.0915E-06	14	4.534E-07	14	1.1014E-08
15	3.913E-06	15	1.1706E-06	15	1.1528E-07
16	0.01748	16	0.00011501	16	0.00073696
17	0.035278	17	0.011274	17	0.0043542
18	0.04959	18	0.033275	18	0.0084758
19	0.057031	19	0.049818	19	0.00067402
20	0.060157	20	0.057755	20	0.036119
21	0.42796	21	0.34395	21	0.012336
22	0.68608	22	0.62731	22	0.23481
23	0.83072	23	0.80412	23	0.57371
24	0.89222	24	0.88229	24	0.78762
25	0.91592	25	0.91281	25	0.8822

Table C.3: *Orthogonal Collocation ($m=3-6, c_{in}^b=1$) - Steady State*

$m = 3$		$m = 4$		$m = 5$		$m = 6$	
p	Error	p	Error	p	Error	p	Error
1	6.58E-12	1	7.01E-12	1	7.38E-12	1	6.60E-12
2	2.05E-11	2	2.23E-11	2	2.05E-11	2	1.64E-11
3	7.32E-11	3	6.86E-11	3	5.99E-11	3	6.88E-11
4	3.16E-10	4	2.45E-11	4	3.59E-10	4	1.38E-10
5	1.16E-10	5	1.41E-09	5	1.54E-09	5	1.36E-09
6	2.62E-11	6	1.29E-11	6	2.01E-11	6	2.37E-11
7	9.23E-11	7	1.59E-10	7	1.00E-10	7	1.25E-10
8	1.30E-09	8	1.19E-09	8	1.13E-09	8	3.56E-11
9	1.38E-08	9	1.30E-10	9	1.30E-10	9	1.30E-10
10	7.55E-08	10	5.53E-10	10	5.53E-10	10	5.53E-10
11	1.10E-10	11	1.02E-10	11	1.02E-10	11	1.02E-10
12	2.75E-10	12	2.59E-10	12	2.59E-10	12	2.59E-10
13	4.59E-10	13	3.78E-10	13	3.78E-10	13	3.78E-10
14	3.82E-10	14	2.53E-10	14	2.52E-10	14	2.53E-10
15	1.58E-08	15	1.60E-08	15	5.85E-10	15	5.85E-10
16	9.60E-05	16	8.87E-06	16	5.27E-07	16	2.95E-08
17	0.00055767	17	1.73E-05	17	2.41E-07	17	7.99E-09
18	0.00021726	18	1.56E-05	18	5.05E-07	18	3.74E-09
19	0.00075201	19	1.30E-05	19	1.68E-07	19	4.09E-09
20	0.0013902	20	5.72E-06	20	1.41E-07	20	1.02E-09
21	0.063523	21	0.0010599	21	0.0015386	21	0.00011304
22	0.13104	22	0.015272	22	0.00010417	22	0.00027878
23	0.17206	23	0.026315	23	0.0021655	23	1.48E-05
24	0.18958	24	0.031372	24	0.0033976	24	0.00019775
25	0.19631	25	0.033357	25	0.0039079	25	0.00029554

Table C.4: *Galerkin (m=1) - Steady State*

$c_{in}^b = 0.1$		$c_{in}^b = 1$		$c_{in}^b = 10$	
p	Error	p	Error	p	Error
1	3.0591E-11	1	4.5361E-12	1	5.6619E-12
2	1.0177E-10	2	1.3622E-11	2	1.7189E-11
3	2.8681E-10	3	5.7064E-11	3	5.9962E-11
4	3.7902E-10	4	3.7830E-10	4	1.8233E-10
5	1.4001E-08	5	9.5189E-09	5	6.2942E-10
6	3.6294E-08	6	1.7063E-09	6	5.8256E-12
7	1.1809E-07	7	4.9684E-09	7	2.0463E-11
8	3.3390E-07	8	3.9604E-09	8	8.3385E-11
9	5.7277E-07	9	2.3113E-07	9	7.4454E-10
10	8.7854E-06	10	2.4799E-07	10	2.0154E-08
11	0.00081656	11	8.5362E-05	11	1.6111E-08
12	0.0024378	12	0.0003278	12	5.8499E-08
13	0.005706	13	0.0013393	13	2.3621E-07
14	0.0099709	14	0.0049222	14	1.788E-06
15	0.013313	15	0.010588	15	0.00019681
16	0.21042	16	0.16742	16	0.024185
17	0.47262	17	0.42483	17	0.12195
18	0.73604	18	0.7164	18	0.42651
19	0.8982	19	0.89492	19	0.79304
20	0.97259	20	0.97253	20	0.95992
21	1.0972	21	1.01	21	0.52206
22	2.3934	22	2.382	22	1.7574
23	3.6233	23	3.6885	23	3.6225
24	4.3499	24	4.4023	24	4.6837
25	4.6763	25	4.6978	25	4.8791

Table C.5: *Galerkin (m=2) - Steady State*

$c_{in}^b = 0.1$		$c_{in}^b = 1$		$c_{in}^b = 10$	
p	Error	p	Error	p	Error
1	6.6024E-12	1	6.2512E-12	1	5.6628E-12
2	2.0443E-11	2	1.9343E-11	2	1.7206E-11
3	8.4772E-11	3	6.1963E-11	3	6.0012E-11
4	7.1315E-10	4	1.7592E-10	4	1.8403E-10
5	1.5839E-08	5	1.2479E-09	5	6.0879E-10
6	3.2913E-10	6	2.1105E-11	6	5.873E-12
7	2.3053E-09	7	1.2954E-10	7	1.8999E-11
8	2.4397E-08	8	1.1602E-09	8	5.1842E-11
9	3.3814E-07	9	1.4055E-08	9	1.6315E-10
10	4.2416E-06	10	7.5286E-08	10	1.0661E-09
11	1.3137E-07	11	6.9587E-09	11	5.6551E-12
12	4.5348E-07	12	1.9344E-08	12	8.1174E-12
13	1.3562E-06	13	3.0376E-09	13	1.025E-10
14	3.0689E-06	14	2.1667E-07	14	8.771E-09
15	4.4688E-06	15	1.1192E-06	15	1.878E-07
16	0.019118	16	0.0076388	16	0.0004336
17	0.037082	17	0.023568	17	0.00016917
18	0.050683	18	0.042706	18	0.00076397
19	0.057496	19	0.054242	19	0.02535
20	0.06031	20	0.059265	20	0.048985
21	0.43461	21	0.39559	21	0.14376
22	0.69212	22	0.68128	22	0.46563
23	0.83387	23	0.83437	23	0.78212
24	0.89347	24	0.8946	24	0.89532
25	0.91632	25	0.91678	25	0.92035

Step Response

Table C.6: *Orthogonal Collocation (m=1) - Step Response*

p	Error	p	Error	p	Error	p	Error	p	Error
1	0.031527	26	0.031465	51	0.029122	76	0.16136	101	0.96537
2	0.029109	27	0.029052	52	0.026922	77	0.1589	102	0.95494
3	0.011746	28	0.011728	53	0.011	78	0.1442	103	0.89102
4	0.00035282	29	0.00034917	54	0.00033602	79	0.12817	104	0.82336
5	0.00010489	30	0.00010596	55	0.00024429	80	0.1252	105	0.81121
6	0.016758	31	0.016744	56	0.015878	81	0.38963	106	2.2531
7	0.014567	32	0.014557	57	0.013821	82	0.38628	107	2.2367
8	0.003922	33	0.0039164	58	0.0036947	83	0.36657	108	2.1414
9	0.00015365	34	0.00015268	59	0.00056672	84	0.34576	109	2.0438
10	0.00011305	35	0.00011407	60	0.00034391	85	0.342	110	2.0265
11	0.004915	36	0.0049186	61	0.0047996	86	0.67197	111	3.5343
12	0.0040883	37	0.0040932	62	0.0039897	87	0.66915	112	3.5215
13	0.00087507	38	0.00086728	63	0.0017963	88	0.65282	113	3.4477
14	0.00014278	39	0.00013913	64	0.0011067	89	0.63606	114	3.3734
15	0.00017858	40	0.00015114	65	0.00095851	90	0.63309	115	3.3603
16	0.00089682	41	0.00090331	66	0.0047825	91	0.86753	116	4.3102
17	0.00074249	42	0.00074569	67	0.0047121	92	0.8661	117	4.3036
18	0.00020039	43	0.00019595	68	0.0042557	93	0.85771	118	4.2678
19	0.00011737	44	0.00011563	69	0.0036897	94	0.84926	119	4.2319
20	0.00011729	45	0.00011667	70	0.0035164	95	0.84778	120	4.2257
21	0.00012004	46	0.00011964	71	0.0099976	96	0.96192	121	4.6631
22	0.00017545	47	0.00019989	72	0.0099722	97	0.96152	122	4.6611
23	0.00011534	48	0.0001925	73	0.0096959	98	0.9585	123	4.6481
24	0.00014172	49	0.00016317	74	0.0094092	99	0.95551	124	4.6357
25	0.00012112	50	0.00016592	75	0.0093415	100	0.955	125	4.6335

Table C.7: *Orthogonal Collocation (m=2) - Step Response*

p	Error	p	Error	p	Error	p	Error	p	Error
1	0.0055869	26	0.0055866	51	0.0055739	76	0.0042285	101	0.34628
2	0.0041255	27	0.0041254	52	0.004118	77	0.0032689	102	0.34371
3	0.00046326	28	0.00046323	53	0.00047469	78	0.0018267	103	0.32832
4	5.82E-05	29	5.8667E-05	54	6.8976E-05	79	0.0013212	104	0.31198
5	9.9423E-05	30	9.8254E-05	55	0.00010981	80	0.0011777	105	0.30902
6	0.0014302	31	0.0014337	56	0.00152	81	0.012715	106	0.62799
7	0.00093221	32	0.00093395	57	0.00099136	82	0.01263	107	0.62572
8	7.7713E-05	33	7.7824E-05	58	7.5699E-05	83	0.012055	108	0.61236
9	0.00012893	34	0.00012913	59	0.0001686	84	0.011424	109	0.59872
10	0.00011372	35	0.00011222	60	8.0034E-05	85	0.011307	110	0.59632
11	0.00019314	36	0.00019454	61	8.7412E-05	86	0.033872	111	0.8043
12	0.00017404	37	0.00017513	62	0.00021091	87	0.033787	112	0.80314
13	7.3065E-05	38	7.7125E-05	63	0.0001354	88	0.033192	113	0.79636
14	0.00014071	39	0.00014417	64	0.00014793	89	0.032563	114	0.78954
15	0.00017611	40	0.00014513	65	0.00013503	90	0.03245	115	0.78834
16	4.1115E-05	41	4.0782E-05	66	3.1084E-05	91	0.049997	116	0.88232
17	5.9759E-05	42	6.0641E-05	67	3.0959E-05	92	0.049976	117	0.88189
18	0.00011134	43	0.00011155	68	8.4162E-05	93	0.049657	118	0.87924
19	0.00011529	44	0.00011407	69	9.5092E-05	94	0.049339	119	0.8766
20	0.00011429	45	0.00010535	70	2.8151E-05	95	0.049282	120	0.87616
21	5.1186E-05	46	5.1571E-05	71	2.4264E-05	96	0.057781	121	0.91281
22	0.0001276	47	0.00019121	72	2.5658E-05	97	0.05779	122	0.91274
23	0.00011336	48	0.00019687	73	3.1507E-05	98	0.057687	123	0.91185
24	0.00014163	49	0.00015761	74	4.0354E-05	99	0.057579	124	0.91103
25	0.00011948	50	0.0001468	75	2.1542E-05	100	0.057565	125	0.91088

Table C.8: *Orthogonal Collocation (m=3) - Step Response*

p	Error	p	Error	p	Error	p	Error	p	Error
1	1.22E-03	26	0.0012204	51	0.0012283	76	0.00019818	101	0.064711
2	6.42E-04	27	0.00064215	52	0.00064744	77	0.0007153	102	0.064381
3	2.65E-05	28	2.65E-05	53	2.88E-05	78	0.0001264	103	0.062388
4	5.63E-05	29	5.66E-05	54	7.37E-05	79	4.35E-05	104	0.060276
5	9.47E-05	30	0.00010412	55	0.00010837	80	7.02E-05	105	0.05989
6	3.50E-05	31	3.51E-05	56	0.00024692	81	0.00054406	106	0.13144
7	9.25E-05	32	9.26E-05	57	5.63E-05	82	0.00055535	107	0.13112
8	4.05E-05	33	4.06E-05	58	3.90E-05	83	0.00052275	108	0.1292
9	1.27E-04	34	0.00012674	59	0.00017264	84	0.00046295	109	0.12725
10	1.06E-04	35	0.00011088	60	8.55E-05	85	0.0004577	110	0.12691
11	3.44E-05	36	3.46E-05	61	3.33E-05	86	0.00021372	111	0.17218
12	3.90E-05	37	3.90E-05	62	3.36E-05	87	0.00021191	112	0.17201
13	7.29E-05	38	7.41E-05	63	0.00013687	88	0.00020474	113	0.17107
14	1.33E-04	39	0.00013102	64	0.00015239	89	0.00020639	114	0.1701
15	1.77E-04	40	0.00013425	65	0.00013537	90	0.00020142	115	0.16993
16	4.13E-05	41	4.07E-05	66	3.09E-05	91	0.00074472	116	0.18961
17	5.98E-05	42	5.91E-05	67	3.11E-05	92	0.00074539	117	0.18955
18	0.00010864	43	0.00011048	68	8.49E-05	93	0.00076716	118	0.18922
19	0.00010736	44	0.00010501	69	9.43E-05	94	0.00077289	119	0.18883
20	0.00011335	45	9.98E-05	70	2.69E-05	95	0.00077037	120	0.18878
21	5.07E-05	46	5.12E-05	71	2.39E-05	96	0.0013762	121	0.19633
22	0.00012469	47	0.00019165	72	2.53E-05	97	0.0013839	122	0.19632
23	8.92E-05	48	0.00015523	73	3.01E-05	98	0.0013959	123	0.1962
24	0.00013694	49	0.00014775	74	3.91E-05	99	0.0013989	124	0.19609
25	0.00011411	50	0.00015193	75	2.07E-05	100	0.0014046	125	0.19606

Table C.9: *Orthogonal Collocation (m=4) - Step Response*

p	Error	p	Error	p	Error	p	Error	p	Error
1	2.70E-05	26	2.71E-05	51	2.88E-05	76	0.00037009	101	0.0010425
2	5.21E-05	27	5.21E-05	52	5.33E-05	77	4.48E-05	102	0.0010604
3	2.65E-05	28	2.65E-05	53	2.73E-05	78	3.45E-05	103	0.0015055
4	5.56E-05	29	5.61E-05	54	7.51E-05	79	8.34E-05	104	0.0016544
5	9.72E-05	30	7.62E-05	55	0.00011347	80	4.88E-05	105	0.0016606
6	2.74E-05	31	2.74E-05	56	2.79E-05	81	2.36E-05	106	0.015259
7	2.97E-05	32	2.97E-05	57	2.99E-05	82	2.69E-05	107	0.01535
8	4.03E-05	33	4.02E-05	58	3.89E-05	83	3.55E-05	108	0.015198
9	1.19E-04	34	0.00012108	59	0.00016505	84	5.48E-05	109	0.01503
10	1.01E-04	35	0.00011271	60	7.69E-05	85	4.97E-05	110	0.015004
11	3.50E-05	36	3.51E-05	61	3.28E-05	86	1.56E-05	111	0.026297
12	3.98E-05	37	3.98E-05	62	3.31E-05	87	1.44E-05	112	0.026316
13	7.25E-05	38	7.31E-05	63	0.00013673	88	3.70E-05	113	0.026218
14	1.37E-04	39	0.00013844	64	0.00015185	89	3.08E-05	114	0.026085
15	1.73E-04	40	0.00012097	65	0.00013601	90	2.98E-05	115	0.02606
16	4.09E-05	41	4.06E-05	66	3.08E-05	91	1.27E-05	116	0.03134
17	5.91E-05	42	5.95E-05	67	3.10E-05	92	1.27E-05	117	0.031345
18	9.12E-05	43	9.18E-05	68	8.57E-05	93	1.42E-05	118	0.031332
19	0.00010963	44	9.31E-05	69	9.58E-05	94	3.50E-05	119	0.031281
20	0.00011311	45	9.70E-05	70	2.90E-05	95	3.54E-05	120	0.031281
21	5.13E-05	46	5.16E-05	71	2.38E-05	96	5.59E-06	121	0.033321
22	0.00012603	47	0.00018917	72	2.42E-05	97	5.59E-06	122	0.033322
23	8.37E-05	48	0.0001697	73	3.11E-05	98	5.78E-06	123	0.033348
24	0.00011355	49	0.00014426	74	3.72E-05	99	6.32E-06	124	0.033341
25	0.00011036	50	0.00015303	75	2.10E-05	100	2.54E-05	125	0.033328

Table C.10: *Orthogonal Collocation (m=5) - Step Response*

p	Error	p	Error	p	Error	p	Error	p	Error
1	1.25E-05	26	1.25E-05	51	1.26E-05	76	9.04E-06	101	0.0015115
2	1.44E-05	27	1.44E-05	52	1.44E-05	77	1.01E-05	102	0.0015204
3	2.62E-05	28	2.60E-05	53	2.69E-05	78	2.47E-05	103	0.0014172
4	5.87E-05	29	5.85E-05	54	6.79E-05	79	7.09E-05	104	0.0013144
5	9.04E-05	30	7.45E-05	55	0.00011762	80	4.14E-05	105	0.001297
6	2.66E-05	31	2.66E-05	56	2.71E-05	81	6.55E-06	106	0.00010211
7	2.98E-05	32	2.97E-05	57	3.01E-05	82	9.62E-06	107	0.00010326
8	3.89E-05	33	3.88E-05	58	3.83E-05	83	2.25E-05	108	0.00010928
9	1.16E-04	34	0.00011996	59	0.00016948	84	3.80E-05	109	0.00013323
10	9.59E-05	35	0.00010015	60	8.07E-05	85	4.02E-05	110	0.0001395
11	3.50E-05	36	3.51E-05	61	3.28E-05	86	7.37E-07	111	0.0021209
12	4.00E-05	37	4.00E-05	62	3.35E-05	87	2.60E-06	112	0.0021225
13	3.37E-05	38	6.74E-05	63	0.00013495	88	2.77E-05	113	0.002174
14	1.13E-04	39	0.00012189	64	0.00014148	89	2.33E-05	114	0.0021643
15	1.71E-04	40	0.00013382	65	0.00013476	90	2.37E-05	115	0.0021616
16	4.13E-05	41	4.07E-05	66	3.09E-05	91	2.28E-07	116	0.0033627
17	5.97E-05	42	6.05E-05	67	3.11E-05	92	2.34E-07	117	0.0033632
18	9.42E-05	43	3.52E-05	68	8.48E-05	93	4.78E-06	118	0.0033894
19	0.00010258	44	8.99E-05	69	9.11E-05	94	2.84E-05	119	0.0034034
20	0.00011577	45	0.00010477	70	3.00E-05	95	2.87E-05	120	0.0034108
21	5.02E-05	46	5.16E-05	71	2.48E-05	96	1.42E-07	121	0.0038675
22	0.00012686	47	0.00018855	72	2.43E-05	97	1.45E-07	122	0.0038672
23	5.12E-05	48	0.00010371	73	3.04E-05	98	2.09E-07	123	0.0038897
24	0.00012387	49	0.00012849	74	3.72E-05	99	9.03E-07	124	0.0039229
25	0.0001163	50	0.00014759	75	2.12E-05	100	2.00E-05	125	0.003912

Table C.11: *Orthogonal Collocation (m=6) - Step Response*

p	Error	p	Error	p	Error	p	Error	p	Error
1	1.58E-05	26	1.58E-05	51	1.59E-05	76	1.04E-05	101	0.00011024
2	1.89E-05	27	1.89E-05	52	1.91E-05	77	1.40E-05	102	0.0001107
3	2.60E-05	28	2.61E-05	53	2.70E-05	78	2.46E-05	103	0.00010044
4	4.33E-05	29	5.22E-05	54	7.18E-05	79	7.50E-05	104	7.78E-05
5	9.52E-05	30	8.59E-05	55	0.00012543	80	4.09E-05	105	7.71E-05
6	2.67E-05	31	2.68E-05	56	2.74E-05	81	6.27E-06	106	0.00027332
7	2.97E-05	32	2.97E-05	57	2.99E-05	82	9.65E-06	107	0.00027487
8	4.03E-05	33	4.02E-05	58	3.88E-05	83	2.19E-05	108	0.00026961
9	1.15E-04	34	0.00011034	59	0.00017193	84	4.01E-05	109	0.00025265
10	7.59E-05	35	9.22E-05	60	8.63E-05	85	3.86E-05	110	0.00025707
11	3.45E-05	36	3.46E-05	61	3.36E-05	86	1.81E-07	111	1.46E-05
12	3.73E-05	37	3.69E-05	62	3.38E-05	87	2.24E-06	112	1.46E-05
13	6.44E-05	38	7.28E-05	63	0.00013494	88	2.79E-05	113	1.53E-05
14	1.13E-04	39	0.00012352	64	0.0001533	89	2.44E-05	114	2.16E-05
15	1.72E-04	40	0.00014487	65	0.00013424	90	2.34E-05	115	3.20E-05
16	4.09E-05	41	4.06E-05	66	3.03E-05	91	6.00E-08	116	0.00019364
17	4.25E-05	42	5.83E-05	67	3.09E-05	92	8.16E-08	117	0.00019364
18	4.33E-05	43	6.37E-05	68	8.46E-05	93	4.74E-06	118	0.00019409
19	8.14E-05	44	8.91E-05	69	9.53E-05	94	2.79E-05	119	0.00019178
20	0.00010343	45	9.66E-05	70	2.80E-05	95	2.87E-05	120	0.00022196
21	4.97E-05	46	5.08E-05	71	2.38E-05	96	2.54E-08	121	0.00034059
22	0.00012611	47	0.00010837	72	2.45E-05	97	1.47E-09	122	0.00028892
23	2.33E-05	48	0.00015551	73	3.10E-05	98	2.10E-07	123	0.00028927
24	9.28E-05	49	0.00011387	74	3.80E-05	99	8.11E-07	124	0.00029867
25	0.00011604	50	0.00013562	75	2.13E-05	100	6.31E-07	125	0.00032632

Table C.12: *Galerkin* ($m=1$) - *Step Response*

p	Error	p	Error	p	Error	p	Error	p	Error
1	0.031524	26	0.031426	51	0.02793	76	0.18199	101	1.0118
2	0.029106	27	0.029016	52	0.025778	77	0.17912	102	1.0001
3	0.011744	28	0.011707	53	0.010373	78	0.16227	103	0.93059
4	0.00035275	29	0.00034848	54	0.00049755	79	0.14401	104	0.85667
5	0.00010305	30	0.00010254	55	0.00031806	80	0.14065	105	0.84344
6	0.016754	31	0.016706	56	0.014452	81	0.43315	106	2.38
7	0.014564	32	0.014522	57	0.012566	82	0.42921	107	2.3616
8	0.0039209	33	0.0039052	58	0.0033287	83	0.40617	108	2.2546
9	0.00015288	34	0.00015038	59	0.00083405	84	0.38185	109	2.145
10	0.00011312	35	0.00011537	60	0.00055859	85	0.37745	110	2.1256
11	0.0049133	36	0.0049	61	0.0048033	86	0.71987	111	3.6861
12	0.0040868	37	0.004078	62	0.0041486	87	0.7167	112	3.6721
13	0.00087472	38	0.00086214	63	0.002719	88	0.69838	113	3.5911
14	0.00014165	39	0.00014099	64	0.0017584	89	0.67957	114	3.5094
15	0.00017871	40	0.00015115	65	0.0015803	90	0.67624	115	3.495
16	0.00089623	41	0.00089714	66	0.0063059	91	0.89615	116	4.4014
17	0.00074202	42	0.00074046	67	0.0062081	92	0.89464	117	4.3946
18	0.00020043	43	0.00019644	68	0.0056218	93	0.88575	118	4.357
19	0.00011695	44	0.00011529	69	0.0049635	94	0.8768	119	4.3193
20	0.00011737	45	0.00011665	70	0.0047775	95	0.87523	120	4.3128
21	0.00012004	46	0.00011943	71	0.011078	96	0.97284	121	4.6977
22	0.00017555	47	0.00020115	72	0.011048	97	0.97243	122	4.6957
23	0.00011543	48	0.00019417	73	0.010751	98	0.96934	123	4.6825
24	0.00014161	49	0.00016475	74	0.010449	99	0.96629	124	4.6698
25	0.00012112	50	0.00016633	75	0.010379	100	0.96576	125	4.6676

Table C.13: *Galerkin* ($m=2$) - *Step Response*

p	Error	p	Error	p	Error	p	Error	p	Error
1	0.0055867	26	0.0055849	51	0.005528	76	0.010265	101	0.39754
2	0.0041253	27	0.0041237	52	0.0040775	77	0.010035	102	0.3943
3	0.00046297	28	0.00046274	53	0.00046237	78	0.0088168	103	0.37495
4	5.7348E-05	29	5.6593E-05	54	7.133E-05	79	0.007578	104	0.35433
5	0.00010424	30	0.00010171	55	0.0001141	80	0.0073152	105	0.3506
6	0.0014302	31	0.0014325	56	0.0015059	81	0.025011	106	0.68179
7	0.00093212	32	0.00093371	57	0.00098101	82	0.02481	107	0.67915
8	7.7208E-05	33	7.7891E-05	58	7.309E-05	83	0.023639	108	0.66366
9	0.00012543	34	0.00012245	59	0.00016545	84	0.022415	109	0.64782
10	0.00011225	35	0.00011517	60	8.2918E-05	85	0.022186	110	0.64503
11	0.00019316	36	0.00019451	61	8.4342E-05	86	0.043275	111	0.83451
12	0.00017394	37	0.00017505	62	0.00020815	87	0.043155	112	0.83326
13	7.6801E-05	38	7.5515E-05	63	0.00013498	88	0.042368	113	0.82601
14	0.00013744	39	0.00014342	64	0.00014987	89	0.041546	114	0.8187
15	0.00016693	40	0.00014207	65	0.00013476	90	0.0414	115	0.81741
16	4.1098E-05	41	4.0867E-05	66	3.106E-05	91	0.054416	116	0.89462
17	6.0004E-05	42	6.0646E-05	67	3.1419E-05	92	0.05439	117	0.89418
18	0.00010916	43	0.00011137	68	8.4788E-05	93	0.054037	118	0.89146
19	0.00011391	44	0.00011339	69	9.5122E-05	94	0.053686	119	0.88876
20	3.3783E-05	45	3.629E-05	70	2.8313E-05	95	0.053623	120	0.8883
21	5.1154E-05	46	5.1567E-05	71	2.4741E-05	96	0.059286	121	0.91679
22	0.00012517	47	0.00018914	72	2.5023E-05	97	0.059299	122	0.9167
23	0.00011491	48	0.00019651	73	3.1805E-05	98	0.059192	123	0.91581
24	7.3015E-05	49	0.00014657	74	3.8514E-05	99	0.05908	124	0.91503
25	2.878E-05	50	4.2344E-05	75	2.1571E-05	100	0.059067	125	0.91484

Table C.14: *Orthogonal Collocation ($m=1$) - Step Response Divided by Stationary Solution*

p	Error	p	Error	p	Error	p	Error	p	Error
1	3.15E-02	26	0.031465	51	0.029134	76	0.013197	101	2.52E-06
2	2.91E-02	27	0.029052	52	0.026934	77	0.011041	102	0.0043626
3	1.17E-02	28	0.011728	53	0.01101	78	0.0018866	103	0.036771
4	3.53E-04	29	0.00034917	54	0.00032299	79	0.015764	104	0.071237
5	1.05E-04	30	0.00010596	55	0.00022668	80	0.018354	105	0.077421
6	1.68E-02	31	0.016744	56	0.015961	81	0.0063639	106	3.15E-08
7	1.46E-02	32	0.014557	57	0.013903	82	0.0039599	107	0.0054613
8	3.92E-03	33	0.0039164	58	0.0037569	83	0.010329	108	0.034746
9	1.54E-04	34	0.00015268	59	0.00047258	84	0.025402	109	0.064744
10	1.13E-04	35	0.00011407	60	0.00024987	85	0.028127	110	0.070046
11	4.92E-03	36	0.004918	61	0.0048796	86	4.30E-07	111	1.31E-08
12	4.09E-03	37	0.0040932	62	0.0040334	87	0.00062128	112	4.10E-08
13	8.75E-04	38	0.00086728	63	0.0011704	88	0.009259	113	0.019511
14	1.43E-04	39	0.00013913	64	0.00048289	89	0.019306	114	0.03591
15	1.79E-04	40	0.00015114	65	0.00033464	90	0.021083	115	0.038785
16	8.97E-04	41	0.00090331	66	0.0012533	91	8.57E-08	116	1.52E-09
17	7.42E-04	42	0.00074569	67	0.0011831	92	7.95E-08	117	3.07E-08
18	2.00E-04	43	0.00019595	68	0.00072885	93	0.0045734	118	0.0081275
19	1.17E-04	44	0.00011563	69	0.00016374	94	0.0091041	119	0.014892
20	0.00011729	45	0.00011667	70	7.59E-05	95	0.0098977	120	0.016067
21	1.20E-04	46	0.00011964	71	0.0004835	96	7.33E-09	121	1.76E-07
22	0.00017545	47	0.00019989	72	0.00045748	97	6.47E-09	122	1.61E-07
23	1.15E-04	48	0.00019251	73	0.00018482	98	3.48E-08	123	1.49E-07
24	1.42E-04	49	0.0001632	74	0.00011334	99	0.0031117	124	0.0048361
25	0.00012112	50	0.00016592	75	0.00016893	100	0.003372	125	0.0052319

Table C.15: *Orthogonal Collocation ($m=2$) - Step Response Divided by Stationary Solution*

p	Error	p	Error	p	Error	p	Error	p	Error
1	5.59E-03	26	0.0055866	51	0.0055739	76	0.0041657	101	2.24E-06
2	4.13E-03	27	0.0041254	52	0.0041179	77	0.0032226	102	2.64E-05
3	4.63E-04	28	0.00046323	53	0.00047468	78	0.0017115	103	0.011629
4	5.82E-05	29	5.87E-05	54	6.89E-05	79	0.0012061	104	0.02379
5	9.94E-05	30	9.83E-05	55	0.00010978	80	0.0010619	105	0.025996
6	1.43E-03	31	0.0014327	56	0.0015157	81	0.0015352	106	3.01E-08
7	9.32E-04	32	0.00093395	57	0.00099127	82	0.0013419	107	9.03E-07
8	7.77E-05	33	7.78E-05	58	7.56E-05	83	0.00077317	108	0.009187
9	1.29E-04	34	0.00012913	59	0.0001685	84	0.00027722	109	0.017567
10	1.14E-04	35	0.00011222	60	8.03E-05	85	0.00027499	110	0.019045
11	1.93E-04	36	0.00019454	61	0.00023837	86	1.42E-07	111	1.49E-08
12	1.74E-04	37	0.00017514	62	0.00021064	87	2.67E-06	112	3.83E-08
13	7.31E-05	38	7.71E-05	63	0.00013644	88	8.89E-05	113	0.0042983
14	1.41E-04	39	0.00014417	64	0.0001477	89	0.00069073	114	0.0080805
15	1.76E-04	40	0.00014514	65	0.00013472	90	0.0008006	115	0.0087446
16	4.11E-05	41	4.08E-05	66	3.14E-05	91	4.36E-08	116	3.73E-10
17	5.98E-05	42	6.07E-05	67	6.95E-05	92	8.82E-08	117	3.43E-08
18	1.11E-04	43	0.00011156	68	8.44E-05	93	0.0001541	118	1.56E-07
19	1.15E-04	44	0.00011409	69	9.54E-05	94	0.00045993	119	0.0030198
20	0.00011429	45	0.00010536	70	2.84E-05	95	0.00051333	120	0.0032644
21	5.12E-05	46	5.16E-05	71	3.37E-05	96	7.87E-09	121	6.07E-10
22	0.0001276	47	0.00019128	72	2.73E-05	97	5.70E-09	122	2.76E-09
23	1.13E-04	48	0.00019695	73	2.96E-05	98	6.48E-05	123	3.39E-09
24	1.42E-04	49	0.00015768	74	3.77E-05	99	0.00016777	124	6.75E-08
25	0.00011948	50	0.00014688	75	2.10E-05	100	0.00017981	125	0.0010109

Table C.16: *Orthogonal Collocation (m=3) - Step Response Divided by Stationary Solution*

p	Error	p	Error	p	Error	p	Error	p	Error
1	1.22E-03	26	0.0012204	51	0.0012283	76	0.00082726	101	1.38E-06
2	6.42E-04	27	0.00064215	52	0.00064744	77	0.00066227	102	0.00080648
3	2.65E-05	28	2.65E-05	53	2.88E-05	78	3.31E-05	103	0.0010675
4	5.63E-05	29	5.66E-05	54	7.37E-05	79	6.43E-05	104	0.0030527
5	9.47E-05	30	0.00010412	55	0.00010837	80	2.93E-05	105	0.0034164
6	3.50E-05	31	3.51E-05	56	0.00024692	81	6.73E-06	106	3.51E-08
7	9.25E-05	32	9.26E-05	57	0.00012058	82	6.21E-06	107	9.34E-07
8	4.05E-05	33	4.06E-05	58	3.90E-05	83	5.37E-05	108	0.0016304
9	1.27E-04	34	0.00012674	59	0.00017264	84	9.88E-05	109	0.0033565
10	1.06E-04	35	0.00011088	60	8.55E-05	85	0.00010212	110	0.0036538
11	3.44E-05	36	3.46E-05	61	3.33E-05	86	3.72E-07	111	9.20E-09
12	3.90E-05	37	3.90E-05	62	3.36E-05	87	2.04E-06	112	3.93E-08
13	7.29E-05	38	7.41E-05	63	0.00013512	88	4.96E-05	113	0.00084544
14	1.33E-04	39	0.00013103	64	0.00015235	89	5.01E-05	114	0.0016724
15	1.77E-04	40	0.00013425	65	0.00013532	90	4.78E-05	115	0.0018189
16	4.14E-05	41	4.08E-05	66	3.09E-05	91	8.77E-08	116	4.38E-10
17	5.98E-05	42	5.91E-05	67	3.16E-05	92	6.34E-08	117	3.02E-08
18	1.09E-04	43	0.00011049	68	8.50E-05	93	1.66E-05	118	2.04E-07
19	1.07E-04	44	0.00010503	69	9.44E-05	94	2.48E-05	119	0.00062885
20	0.00011335	45	9.99E-05	70	2.75E-05	95	2.59E-05	120	0.00068252
21	5.07E-05	46	5.13E-05	71	2.34E-05	96	2.36E-08	121	1.14E-09
22	0.00012469	47	0.00018931	72	2.62E-05	97	4.21E-09	122	8.30E-08
23	8.92E-05	48	0.00015549	73	2.96E-05	98	9.44E-08	123	3.50E-08
24	1.37E-04	49	0.00014769	74	3.81E-05	99	1.19E-05	124	0.00018219
25	0.00011411	50	0.000152	75	2.08E-05	100	1.69E-05	125	0.00021003

Table C.17: *Orthogonal Collocation (m=4) - Step Response Divided by Stationary Solution*

p	Error	p	Error	p	Error	p	Error	p	Error
1	2.70E-05	26	2.71E-05	51	2.88E-05	76	0.0003618	101	8.72E-07
2	5.21E-05	27	5.21E-05	52	4.90E-05	77	3.68E-05	102	1.32E-05
3	2.65E-05	28	2.65E-05	53	2.73E-05	78	2.57E-05	103	0.0004468
4	5.56E-05	29	5.61E-05	54	7.51E-05	79	7.45E-05	104	0.0005815
5	9.72E-05	30	7.62E-05	55	0.00011347	80	3.99E-05	105	0.00060131
6	2.74E-05	31	2.74E-05	56	2.79E-05	81	6.77E-06	106	3.10E-08
7	2.97E-05	32	2.97E-05	57	2.99E-05	82	1.06E-05	107	9.70E-07
8	4.03E-05	33	4.02E-05	58	3.89E-05	83	1.97E-05	108	7.91E-05
9	1.19E-04	34	0.00012108	59	0.00016505	84	3.77E-05	109	0.00024298
10	1.01E-04	35	0.00011271	60	7.69E-05	85	3.68E-05	110	0.00026439
11	3.50E-05	36	3.51E-05	61	3.28E-05	86	3.94E-07	111	1.24E-08
12	3.98E-05	37	3.98E-05	62	3.31E-05	87	2.30E-06	112	3.91E-08
13	7.25E-05	38	7.37E-05	63	0.00013625	88	2.63E-05	113	1.22E-06
14	1.37E-04	39	0.00013845	64	0.00015127	89	2.47E-05	114	0.00022609
15	1.73E-04	40	0.00012098	65	0.00013598	90	2.30E-05	115	0.00025023
16	4.09E-05	41	4.06E-05	66	3.10E-05	91	4.21E-08	116	4.64E-10
17	5.91E-05	42	5.95E-05	67	3.24E-05	92	8.79E-08	117	3.59E-08
18	9.12E-05	43	9.18E-05	68	8.52E-05	93	1.41E-05	118	1.37E-07
19	1.10E-04	44	9.31E-05	69	9.58E-05	94	2.63E-05	119	9.00E-05
20	0.00011311	45	9.70E-05	70	2.89E-05	95	2.77E-05	120	9.85E-05
21	5.13E-05	46	5.16E-05	71	2.36E-05	96	1.08E-08	121	5.17E-10
22	0.00012603	47	0.00018917	72	2.59E-05	97	1.16E-08	122	1.79E-09
23	8.37E-05	48	0.0001697	73	2.97E-05	98	7.73E-06	123	5.88E-08
24	1.14E-04	49	0.00014356	74	3.76E-05	99	1.42E-05	124	1.29E-07
25	0.00011036	50	0.00015304	75	2.10E-05	100	2.16E-05	125	3.23E-05

Table C.18: *Orthogonal Collocation (m=5) - Step Response Divided by Stationary Solution*

p	Error	p	Error	p	Error	p	Error	p	Error
1	1.25E-05	26	1.25E-05	51	1.26E-05	76	9.13E-06	101	1.04E-06
2	1.44E-05	27	1.44E-05	52	1.44E-05	77	1.04E-05	102	4.71E-07
3	2.62E-05	28	2.60E-05	53	2.69E-05	78	2.51E-05	103	0.00012778
4	5.87E-05	29	5.85E-05	54	6.79E-05	79	7.19E-05	104	0.00023403
5	9.04E-05	30	7.45E-05	55	0.00011762	80	4.12E-05	105	0.00024807
6	2.66E-05	31	2.66E-05	56	2.71E-05	81	6.54E-06	106	2.44E-08
7	2.98E-05	32	2.97E-05	57	3.01E-05	82	9.64E-06	107	9.16E-07
8	3.89E-05	33	3.88E-05	58	3.83E-05	83	2.25E-05	108	4.87E-05
9	1.16E-04	34	0.00011996	59	0.00016948	84	3.75E-05	109	6.75E-05
10	9.59E-05	35	0.00010015	60	8.07E-05	85	4.06E-05	110	7.65E-05
11	3.50E-05	36	3.51E-05	61	3.28E-05	86	3.61E-07	111	1.59E-08
12	4.00E-05	37	4.00E-05	62	3.35E-05	87	2.13E-06	112	3.64E-08
13	3.37E-05	38	6.74E-05	63	0.00013621	88	2.73E-05	113	7.63E-07
14	1.13E-04	39	0.00012189	64	0.000143	89	2.36E-05	114	9.40E-06
15	1.71E-04	40	0.00013382	65	0.00013462	90	2.35E-05	115	1.15E-05
16	4.13E-05	41	4.07E-05	66	3.09E-05	91	9.64E-08	116	3.07E-09
17	5.97E-05	42	6.05E-05	67	3.20E-05	92	1.02E-07	117	2.87E-08
18	9.42E-05	43	3.52E-05	68	8.51E-05	93	1.45E-05	118	1.80E-07
19	1.03E-04	44	8.99E-05	69	9.10E-05	94	2.77E-05	119	1.19E-05
20	0.00011577	45	0.00010477	70	3.00E-05	95	2.76E-05	120	2.01E-05
21	5.02E-05	46	5.16E-05	71	2.36E-05	96	6.00E-09	121	1.69E-07
22	0.00012686	47	0.00018855	72	2.61E-05	97	9.70E-09	122	1.79E-06
23	5.12E-05	48	0.00010368	73	2.96E-05	98	1.15E-07	123	5.15E-08
24	1.24E-04	49	0.00012857	74	3.74E-05	99	1.43E-05	124	9.05E-08
25	0.0001163	50	0.00014758	75	2.10E-05	100	2.14E-05	125	1.54E-07

Table C.19: *Orthogonal Collocation (m=6) - Step Response Divided by Stationary Solution*

p	Error	p	Error	p	Error	p	Error	p	Error
1	1.58E-05	26	1.58E-05	51	1.59E-05	76	1.04E-05	101	1.07E-06
2	1.89E-05	27	1.89E-05	52	1.91E-05	77	1.40E-05	102	1.29E-06
3	2.60E-05	28	2.61E-05	53	2.70E-05	78	2.45E-05	103	1.43E-05
4	4.33E-05	29	5.22E-05	54	7.18E-05	79	7.50E-05	104	4.24E-05
5	9.52E-05	30	8.59E-05	55	0.00012543	80	4.06E-05	105	4.04E-05
6	2.67E-05	31	2.68E-05	56	2.74E-05	81	6.27E-06	106	4.18E-08
7	2.97E-05	32	2.97E-05	57	2.99E-05	82	9.65E-06	107	9.64E-07
8	4.03E-05	33	4.02E-05	58	3.88E-05	83	2.19E-05	108	1.99E-05
9	1.15E-04	34	0.00011034	59	0.00017232	84	4.01E-05	109	3.14E-05
10	7.59E-05	35	9.22E-05	60	8.64E-05	85	3.85E-05	110	4.10E-05
11	3.45E-05	36	3.46E-05	61	3.36E-05	86	1.80E-07	111	8.13E-09
12	3.73E-05	37	3.69E-05	62	3.38E-05	87	2.24E-06	112	2.48E-08
13	6.44E-05	38	7.28E-05	63	0.00013566	88	2.79E-05	113	7.78E-07
14	1.13E-04	39	0.00012349	64	0.00015405	89	2.44E-05	114	2.12E-05
15	1.72E-04	40	0.00014487	65	0.00013434	90	2.29E-05	115	2.08E-05
16	4.09E-05	41	4.06E-05	66	3.07E-05	91	5.73E-08	116	5.60E-10
17	4.25E-05	42	5.83E-05	67	3.26E-05	92	7.88E-08	117	3.68E-08
18	4.33E-05	43	6.37E-05	68	8.45E-05	93	1.39E-05	118	1.41E-07
19	8.14E-05	44	8.91E-05	69	9.62E-05	94	2.61E-05	119	1.97E-05
20	0.00010343	45	9.66E-05	70	2.83E-05	95	2.76E-05	120	2.90E-05
21	4.97E-05	46	5.08E-05	71	2.34E-05	96	2.52E-08	121	4.53E-05
22	0.00012611	47	0.00010826	72	2.58E-05	97	1.26E-09	122	8.60E-06
23	2.33E-05	48	0.00015551	73	2.94E-05	98	7.48E-06	123	1.06E-06
24	9.28E-05	49	0.00011463	74	3.75E-05	99	1.43E-05	124	8.48E-06
25	0.00011604	50	0.00013562	75	2.11E-05	100	2.14E-05	125	6.24E-05

Table C.20: *Galerkin (m=1) - Step Response Divided by Stationary Solution*

p	Error	p	Error	p	Error	p	Error	p	Error
1	3.15E-02	26	0.031426	51	0.027989	76	0.012482	101	2.50E-06
2	2.91E-02	27	0.029016	52	0.025835	77	0.010021	102	0.0049503
3	1.17E-02	28	0.011707	53	0.010424	78	0.0044112	103	0.039512
4	3.53E-04	29	0.00034848	54	0.00041215	79	0.020047	104	0.076287
5	1.03E-04	30	0.00010254	55	0.00023268	80	0.022925	105	0.082869
6	1.68E-02	31	0.016706	56	0.01468	81	0.0058397	106	3.76E-08
7	1.46E-02	32	0.014522	57	0.012759	82	0.0030953	107	0.0060434
8	3.92E-03	33	0.0039052	58	0.0033575	83	0.0131	108	0.037672
9	1.53E-04	34	0.00015038	59	0.00050609	84	0.030164	109	0.070095
10	1.13E-04	35	0.00011537	60	0.00023072	85	0.033251	110	0.075824
11	4.91E-03	36	0.0049	61	0.0042754	86	3.26E-07	111	8.93E-09
12	4.09E-03	37	0.004078	62	0.0035133	87	2.22E-06	112	6.29E-08
13	8.75E-04	38	0.00086214	63	0.0013771	88	0.010502	113	0.020778
14	1.42E-04	39	0.00014099	64	0.00041776	89	0.021459	114	0.03821
15	1.79E-04	40	0.00015115	65	0.00024449	90	0.0234	115	0.041266
16	8.96E-04	41	0.0008969	66	0.0013772	91	6.89E-08	116	1.02E-09
17	7.42E-04	42	0.00074046	67	0.0012799	92	5.67E-08	117	3.79E-08
18	2.00E-04	43	0.00019644	68	0.00069699	93	0.0048412	118	0.0083893
19	1.17E-04	44	0.00011529	69	9.86E-05	94	0.009566	119	0.015367
20	0.00011737	45	0.00011665	70	0.00015658	95	0.010395	120	0.016579
21	1.20E-04	46	0.00011943	71	0.00048542	96	7.90E-09	121	4.29E-06
22	0.00017555	47	0.00020115	72	0.00045529	97	5.26E-09	122	6.17E-09
23	1.15E-04	48	0.00019407	73	0.00016189	98	1.26E-07	123	2.79E-07
24	1.42E-04	49	0.00016475	74	0.00014773	99	0.0031661	124	0.0048903
25	0.00012112	50	0.00016635	75	0.00020868	100	0.0034299	125	0.005291

Table C.21: *Galerkin (m=2) - Step Response Divided by Stationary Solution*

p	Error	p	Error	p	Error	p	Error	p	Error
1	5.59E-03	26	0.0055849	51	0.005528	76	0.003665	101	1.68E-06
2	4.13E-03	27	0.0041237	52	0.0040775	77	0.0028132	102	0.00095557
3	4.63E-04	28	0.00046274	53	0.00046236	78	0.0011692	103	0.014794
4	5.73E-05	29	5.66E-05	54	7.13E-05	79	0.00021446	104	0.029563
5	1.04E-04	30	0.00010171	55	0.00011409	80	0.00036622	105	0.032241
6	1.43E-03	31	0.0014325	56	0.0015042	81	3.33E-06	106	3.18E-08
7	9.32E-04	32	0.00093371	57	0.000981	82	0.0012142	107	9.30E-07
8	7.72E-05	33	7.79E-05	58	7.31E-05	83	7.07E-05	108	0.010478
9	1.25E-04	34	0.00012245	59	0.0001643	84	0.0011296	109	0.019898
10	1.12E-04	35	0.00011517	60	8.25E-05	85	0.001351	110	0.02156
11	1.93E-04	36	0.00019451	61	8.43E-05	86	2.78E-07	111	1.44E-08
12	1.74E-04	37	0.00017505	62	0.00020921	87	2.85E-06	112	3.24E-08
13	7.68E-05	38	7.55E-05	63	0.00013447	88	0.00032258	113	0.0045561
14	1.37E-04	39	0.00014342	64	0.00014987	89	0.0011127	114	0.008543
15	1.67E-04	40	0.00014207	65	0.00013479	90	0.0012536	115	0.0092438
16	4.11E-05	41	4.09E-05	66	9.01E-05	91	5.89E-08	116	8.10E-06
17	6.00E-05	42	6.07E-05	67	6.88E-05	92	8.25E-08	117	8.83E-08
18	1.09E-04	43	0.00011139	68	8.50E-05	93	0.000196	118	4.15E-06
19	1.14E-04	44	0.0001134	69	9.53E-05	94	0.00053105	119	0.0030842
20	3.38E-05	45	3.63E-05	70	2.84E-05	95	0.00059002	120	0.0033394
21	5.12E-05	46	5.16E-05	71	3.33E-05	96	1.25E-05	121	8.33E-06
22	0.00012517	47	0.00018921	72	2.59E-05	97	1.62E-08	122	1.59E-05
23	1.15E-04	48	0.00019659	73	2.98E-05	98	1.26E-07	123	1.14E-06
24	7.30E-05	49	0.00014665	74	3.76E-05	99	1.10E-06	124	0.00096374
25	2.88E-05	50	4.24E-05	75	2.10E-05	100	0.00018795	125	0.0010372

Impulse Response

Table C.22: *Orthogonal Collocation (m=1) - Impulse Response*

p	Error	p	Error	p	Error	p	Error	p	Error
1	0.6993	26	0.69945	51	0.70473	76	0.76952	101	0.7653
2	0.39183	27	0.39189	52	0.394	77	0.41524	102	0.33835
3	0.085211	28	0.085169	53	0.083744	78	0.058418	103	0.50501
4	0.0040779	29	0.0040423	54	0.0035886	79	0.16317	104	0.93654
5	0.00051826	30	0.00052111	55	0.00042349	80	0.20099	105	1.0608
6	0.52319	31	0.52459	56	0.57043	81	0.81281	106	1.2519E-06
7	0.306	32	0.30676	57	0.33162	82	0.43584	107	0.78635
8	0.050422	33	0.050475	58	0.051899	83	0.25523	108	1.6358
9	0.0014493	34	0.0014311	59	0.0014681	84	0.4346	109	2.2581
10	0.0013638	35	0.0013697	60	0.0016008	85	0.46673	110	2.3615
11	0.2487	36	0.25239	61	0.36105	86	0.69576	111	7.0455E-05
12	0.15298	37	0.15527	62	0.2229	87	0.40743	112	2.8814E-05
13	0.020402	38	0.020612	63	0.028721	88	0.57349	113	3.0709
14	0.00070593	39	0.00070484	64	0.0041709	89	0.7139	114	3.5409
15	0.0027362	40	0.0027143	65	0.0049423	90	0.72438	115	3.5771
16	0.077519	41	0.082032	66	0.20544	91	0.00013036	116	0.0005533
17	0.056399	42	0.059783	67	0.15962	92	7.9215E-05	117	0.0011116
18	0.0071063	43	0.00074859	68	0.015851	93	0.81567	118	4.0441
19	0.0021384	44	0.0022366	69	0.008649	94	0.88902	119	4.3017
20	0.0067403	45	0.0072604	70	0.0068002	95	0.87471	120	4.2759
21	0.019866	46	0.0012538	71	0.10654	96	0.00073263	121	0.00054986
22	0.014886	47	0.0011052	72	0.10169	97	0.0010927	122	0.00034949
23	0.0011981	48	0.0036559	73	0.013285	98	1.5079E-05	123	5.0812E-05
24	0.0053219	49	0.0056439	74	0.010455	99	0.0011081	124	0.0023844
25	0.0067205	50	0.010226	75	0.013637	100	0.93235	125	0.0018285

Table C.23: *Orthogonal Collocation (m=2) - Impulse Response*

p	Error	p	Error	p	Error	p	Error	p	Error
1	0.37131	26	0.37142	51	0.37536	76	0.42394	101	0.4743
2	0.16178	27	0.16183	52	0.16369	77	0.184	102	0.20433
3	0.011289	28	0.011297	53	0.011557	78	0.013814	103	0.060288
4	0.00012007	29	0.0001205	54	0.00014533	79	0.0043311	104	0.32685
5	0.0003436	30	0.00034252	55	0.00048907	80	0.015403	105	0.40984
6	0.16951	31	0.17007	56	0.18846	81	0.29731	106	1.9152E-06
7	0.072861	32	0.073123	57	0.081722	82	0.13173	107	2.5218E-05
8	0.0036301	33	0.0036494	58	0.0042308	83	0.011797	108	0.33085
9	0.00026333	34	0.00026335	59	0.00029442	84	0.025081	109	0.62816
10	0.0013428	35	0.0013485	60	0.0010677	85	0.034625	110	0.67852
11	0.050595	36	0.051437	61	0.076148	86	1.4967E-05	111	2.4984E-05
12	0.025405	37	0.02586	62	0.03934	87	2.8983E-05	112	2.87E-05
13	0.00020018	38	0.00020142	63	0.00019832	88	0.012067	113	0.62497
14	0.0006978	39	0.00069953	64	0.0009189	89	0.044564	114	0.80546
15	0.0027184	40	0.0027185	65	0.0036281	90	0.045216	115	0.81926
16	0.017136	41	0.018172	66	0.044477	91	0.00017295	116	0.00034742
17	0.0070937	42	0.0075466	67	0.019831	92	0.00021609	117	0.00027488
18	0.00053417	43	0.00069684	68	0.00049159	93	0.00044954	118	2.7736E-05
19	0.0021318	44	0.0022755	69	0.0018078	94	0.05574	119	0.0010415
20	0.0066438	45	0.0072262	70	0.013518	95	0.04734	120	0.87662
21	0.0039938	46	0.0046412	71	0.016185	96	0.00076949	121	0.0010989
22	0.0010913	47	0.0011748	72	0.0011402	97	0.0023663	122	0.0010346
23	0.0011968	48	0.0012927	73	0.0019147	98	0.0024195	123	4.485E-05
24	0.0052727	49	0.0055866	74	0.0058233	99	0.0026854	124	0.00063272
25	0.0066889	50	0.01008	75	0.017688	100	0.024393	125	0.003715

Table C.24: *Orthogonal Collocation (m=3) - Impulse Response*

p	Error	p	Error	p	Error	p	Error	p	Error
1	1.77E-01	26	0.18308	51	0.18523	76	0.20713	101	0.24476
2	5.56E-02	27	0.055573	52	0.056272	77	0.065209	102	0.080018
3	1.71E-03	28	0.0017109	53	0.0017527	78	0.0024204	103	0.010445
4	1.13E-04	29	0.00011291	54	0.00013398	79	0.00027786	104	0.05494
5	3.43E-04	30	0.00034073	55	0.00049373	80	0.00025583	105	0.10037
6	5.65E-02	31	0.056668	56	0.062724	81	0.1029	106	2.82E-06
7	1.85E-02	32	0.018571	57	0.020757	82	0.035975	107	8.89E-06
8	1.06E-04	33	0.00010672	58	0.00013228	83	0.00052444	108	0.021795
9	2.53E-04	34	0.00025695	59	0.00029534	84	0.00047664	109	0.13071
10	1.33E-03	35	0.0013508	60	0.0010748	85	0.00070882	110	0.15703
11	1.82E-02	36	0.018523	61	0.027189	86	2.24E-05	111	2.06E-05
12	2.06E-04	37	0.00020856	62	0.00021206	87	1.85E-05	112	3.36E-05
13	1.95E-04	38	0.00019323	63	0.00021631	88	0.0005662	113	0.08865
14	7.00E-04	39	0.00070746	64	0.00094914	89	0.00034629	114	0.17247
15	2.70E-03	40	0.0026529	65	0.0035602	90	0.003652	115	0.17811
16	1.02E-03	41	0.0010215	66	0.010231	91	0.00010921	116	0.00022056
17	4.37E-04	42	0.00042664	67	0.00032552	92	0.00024139	117	0.00047732
18	5.35E-04	43	0.00065857	68	0.00047853	93	0.00027015	118	4.55E-05
19	2.17E-03	44	0.0022462	69	0.0017954	94	0.0031268	119	0.00089853
20	0.0065892	45	0.007212	70	0.013586	95	0.015182	120	0.1894
21	1.34E-03	46	0.0014337	71	0.0011846	96	0.00065995	121	0.00082605
22	0.0011081	47	0.0011681	72	0.000991	97	0.0020796	122	0.0031089
23	1.18E-03	48	0.0012813	73	0.0019791	98	0.0017907	123	0.0029067
24	5.16E-03	49	0.0054687	74	0.010105	99	0.004948	124	0.01262
25	0.0066291	50	0.01033	75	0.017782	100	0.0077711	125	0.034834

Table C.25: *Orthogonal Collocation (m=4) - Impulse Response*

p	Error	p	Error	p	Error	p	Error	p	Error
1	8.17E-02	26	0.15823	51	0.099766	76	0.10694	101	0.11819
2	1.89E-02	27	0.018884	52	0.0191	77	0.022485	102	0.028242
3	3.95E-04	28	0.0003957	53	0.0004037	78	0.00051178	103	0.002491
4	1.12E-04	29	0.00011234	54	0.00013264	79	0.00018492	104	0.0041377
5	3.42E-04	30	0.00033654	55	0.00048459	80	0.00040385	105	0.013888
6	2.24E-02	31	0.022428	56	0.024721	81	0.040756	106	6.31E-06
7	3.65E-04	32	0.00036534	57	0.00038271	82	0.0099043	107	3.27E-06
8	7.76E-05	33	7.81E-05	58	9.52E-05	83	0.0001277	108	0.0047109
9	2.59E-04	34	0.00025836	59	0.0002988	84	0.00049549	109	0.015547
10	1.34E-03	35	0.0013487	60	0.0010677	85	0.0013286	110	0.025657
11	6.77E-03	36	0.006874	61	0.0014933	86	1.38E-05	111	2.86E-05
12	1.73E-03	37	0.0017548	62	0.00022478	87	1.75E-05	112	7.79E-05
13	1.96E-04	38	0.00019509	63	0.00021055	88	0.00023863	113	4.48E-05
14	7.04E-04	39	0.00070155	64	0.00091709	89	0.0010185	114	0.026363
15	2.71E-03	40	0.0026996	65	0.0036634	90	0.0050356	115	0.00060319
16	1.73E-03	41	0.0017782	66	0.0026695	91	0.00015592	116	0.0001372
17	4.39E-04	42	0.00042914	67	0.00030599	92	0.0002072	117	0.00046513
18	5.02E-04	43	0.00068548	68	0.00047585	93	0.00049391	118	0.0001214
19	2.16E-03	44	0.002233	69	0.0025311	94	0.0046002	119	0.0010807
20	0.0066534	45	0.0072276	70	0.01346	95	0.016478	120	0.032838
21	1.39E-03	46	0.001334	71	0.0011189	96	0.00079552	121	0.00057286
22	0.0010905	47	0.0011617	72	0.0010231	97	0.0022142	122	0.0020603
23	1.15E-03	48	0.0012641	73	0.0021655	98	0.0025636	123	0.0035282
24	5.21E-03	49	0.005436	74	0.0058882	99	0.0043962	124	4.00E-05
25	0.0065212	50	0.010628	75	0.034776	100	0.017175	125	0.026856

Table C.26: *Orthogonal Collocation (m=5) - Impulse Response*

p	Error	p	Error	p	Error	p	Error	p	Error
1	3.69E-02	26	0.036932	51	0.057747	76	0.059863	101	0.063201
2	6.06E-03	27	0.0060636	52	0.006118	77	0.0074124	102	0.010957
3	4.16E-05	28	4.16E-05	53	4.23E-05	78	4.38E-05	103	0.00074082
4	1.12E-04	29	0.00011142	54	0.00013143	79	0.00019037	104	0.00093144
5	3.34E-04	30	0.00033836	55	0.00049268	80	0.00040737	105	0.00040173
6	1.18E-02	31	0.011852	56	0.012992	81	0.021678	106	3.82E-06
7	1.55E-04	32	0.00015477	57	0.00015266	82	4.22E-05	107	1.85E-06
8	7.62E-05	33	7.79E-05	58	9.57E-05	83	0.00010478	108	3.66E-05
9	2.61E-04	34	0.00025605	59	0.00029677	84	0.00046719	109	0.00056329
10	1.35E-03	35	0.0013547	60	0.00087002	85	0.0012075	110	0.0025094
11	1.87E-03	36	0.0018944	61	0.0024058	86	2.35E-05	111	6.25E-05
12	2.42E-04	37	0.00024348	62	0.00024896	87	2.55E-05	112	2.44E-05
13	1.84E-04	38	0.00020002	63	0.00020501	88	0.00025444	113	6.00E-05
14	7.07E-04	39	0.00073198	64	0.00087857	89	0.0010015	114	0.0021502
15	2.66E-03	40	0.0026384	65	0.003169	90	0.0047757	115	0.0019252
16	1.08E-03	41	0.0010862	66	0.00090968	91	9.49E-05	116	0.00025679
17	4.33E-04	42	0.00044697	67	0.00032022	92	0.00043847	117	0.00064786
18	5.08E-04	43	0.0006496	68	0.00047514	93	0.0010489	118	1.86E-05
19	2.17E-03	44	0.0022179	69	0.0021775	94	0.00461	119	0.0020994
20	0.0066341	45	0.0070326	70	0.011562	95	0.020546	120	0.018025
21	1.41E-03	46	0.0013411	71	0.0011073	96	0.00079665	121	0.00095323
22	0.0011038	47	0.0011826	72	0.00097069	97	0.0022587	122	0.0027162
23	1.10E-03	48	0.0010563	73	0.0019781	98	0.000721	123	3.60E-06
24	5.22E-03	49	0.0055344	74	0.017528	99	0.0088715	124	0.011252
25	0.0069142	50	0.010436	75	0.050389	100	0.020716	125	0.030607

Table C.27: *Orthogonal Collocation (m=6) - Impulse Response*

p	Error	p	Error	p	Error	p	Error	p	Error
1	1.86E-02	26	0.018602	51	0.038793	76	0.039526	101	0.040632
2	2.52E-03	27	0.0025158	52	0.0025301	77	0.0031112	102	0.0047115
3	4.37E-05	28	4.37E-05	53	4.45E-05	78	5.07E-05	103	0.00013357
4	1.12E-04	29	0.00011313	54	0.00013115	79	0.00018532	104	0.00020811
5	3.35E-04	30	0.00034291	55	0.00049353	80	0.00041566	105	0.0006672
6	6.35E-04	31	0.0059472	56	0.0058552	81	0.010212	106	3.92E-06
7	1.73E-04	32	0.00017304	57	0.00017844	82	3.59E-05	107	4.48E-06
8	7.82E-05	33	7.92E-05	58	9.43E-05	83	0.00010495	108	0.00012137
9	2.64E-04	34	0.00026288	59	0.00028107	84	0.00047705	109	0.00071155
10	1.36E-03	35	0.0013408	60	0.00086065	85	0.0012436	110	0.002406
11	1.49E-03	36	0.0015096	61	0.001834	86	2.11E-05	111	2.87E-05
12	2.42E-04	37	0.00024352	62	0.00025008	87	2.14E-05	112	2.87E-05
13	1.89E-04	38	0.00019084	63	0.00021465	88	0.00027515	113	0.00028023
14	7.01E-04	39	0.00070424	64	0.00093274	89	0.0010369	114	0.00098911
15	2.70E-03	40	0.002651	65	0.0033147	90	0.0048246	115	0.0052521
16	1.10E-03	41	0.0011099	66	0.00095301	91	0.00018492	116	0.00021076
17	4.32E-04	42	0.00044297	67	0.00031952	92	0.00010171	117	0.00046021
18	4.95E-04	43	0.00062742	68	0.00047117	93	0.00045723	118	0.00019838
19	2.14E-03	44	0.0022805	69	0.0023509	94	0.0043515	119	0.0012198
20	0.0065846	45	0.0070762	70	0.013684	95	0.018039	120	0.01149
21	1.39E-03	46	0.0013329	71	0.0011406	96	0.0010189	121	0.0013683
22	0.0010983	47	0.0011818	72	0.0009879	97	0.0021564	122	0.0019606
23	9.81E-04	48	0.0010661	73	0.0020065	98	0.00047521	123	0.0049144
24	5.74E-03	49	0.0057442	74	0.010294	99	0.0046002	124	0.0073136
25	0.0065582	50	0.011171	75	0.043105	100	0.00075702	125	0.059615

Table C.28: *Galerkin (m=1) - Impulse Response*

p	Error	p	Error	p	Error	p	Error	p	Error
1	0.6993	26	0.69946	51	0.70501	76	0.77035	101	10.326
2	0.39183	27	0.3919	52	0.3943	77	0.42111	102	11.427
3	0.085213	28	0.085187	53	0.084395	78	2.3238	103	31.137
4	0.0040776	29	0.004035	54	0.0029365	79	0.17807	104	0.96844
5	0.00051796	30	0.00051821	55	0.00050051	80	0.20507	105	1.0699
6	0.52319	31	0.52461	56	0.57109	81	0.82283	106	313.78
7	0.306	32	0.30677	57	0.33191	82	25.955	107	413.3
8	0.050424	33	0.050497	58	0.051564	83	58.941	108	1215.8
9	0.0014488	34	0.0014263	59	0.0011513	84	0.45001	109	2.302
10	0.0013638	35	0.0013693	60	0.0016939	85	0.47015	110	2.3714
11	0.24869	36	0.25234	61	0.3625	86	0.73605	111	8192.6
12	0.15297	37	0.15514	62	0.23099	87	615.17	112	13790
13	0.020409	38	0.020679	63	0.02578	88	0.64685	113	3.2971
14	0.00070591	39	0.0007048	64	0.0050016	89	0.72391	114	3.5736
15	0.0027362	40	0.0027142	65	0.0049925	90	0.72634	115	3.5843
16	0.07749	41	0.081821	66	0.22116	91	3.3934E-06	116	1.4499e+005
17	0.056403	42	0.059965	67	0.15305	92	16418	117	4.0408e+005
18	0.0071069	43	0.0076032	68	0.0165	93	0.85615	118	4.179
19	0.0021383	44	0.0022341	69	0.0088353	94	0.89352	119	4.3174
20	0.0067392	45	0.0072603	70	0.0068096	95	0.87549	120	4.3299
21	0.0011332	46	0.024801	71	0.11549	96	5.8964E-06	121	1.9088e+006
22	0.014858	47	0.018195	72	0.099181	97	2.7499E-05	122	0.0014326
23	0.001194	48	0.0013307	73	0.013931	98	7.6602E-05	123	0.0017741
24	0.0053221	49	0.0056437	74	0.010538	99	0.9658	124	0.001461
25	0.0067204	50	0.010226	75	0.033147	100	0.92485	125	4.6042

Table C.29: *Galerkin (m=2) - Impulse Response*

p	Error	p	Error	p	Error	p	Error	p	Error
1	0.37131	26	0.37144	51	0.37597	76	0.47071	101	10.365
2	0.16178	27	0.16185	52	0.16429	77	0.20645	102	11.837
3	0.011289	28	0.01129	53	0.011447	78	0.020103	103	31.963
4	0.00011989	29	0.00011871	54	0.00021611	79	0.010882	104	0.37184
5	0.00034357	30	0.00034245	55	0.00048547	80	0.017719	105	0.42205
6	0.16952	31	0.17013	56	0.19043	81	0.32062	106	314.22
7	0.072861	32	0.07313	57	0.12258	82	0.14107	107	415.59
8	0.0036281	33	0.0036308	58	0.0049582	83	0.013087	108	1217.2
9	0.00026324	34	0.00026247	59	0.00028067	84	0.031172	109	0.66081
10	0.0012939	35	0.00093691	60	0.0010679	85	0.036128	110	0.68629
11	0.050575	36	0.05124	61	0.078806	86	0.00018963	111	8196.2
12	0.025406	37	0.025863	62	0.03911	87	0.14863	112	13799
13	0.0001979	38	0.0001787	63	0.0021934	88	0.032203	113	0.7346
14	0.00067362	39	0.00064357	64	0.00090403	89	0.047868	114	0.82131
15	0.0023189	40	0.0018074	65	0.0034621	90	0.047322	115	0.8251
16	0.017143	41	0.018245	66	0.045745	91	0.0013229	116	1.45e+005
17	0.0070637	42	0.00036013	67	0.02212	92	0.0010055	117	4.0407e+005
18	0.00053361	43	0.00068927	68	0.0013256	93	0.00041905	118	7.4986E-05
19	0.0018713	44	0.00094455	69	0.0022647	94	0.057636	119	0.88761
20	0.0057193	45	0.0031113	70	0.013499	95	0.088888	120	0.92449
21	0.0040052	46	0.0047509	71	0.016686	96	0.0060367	121	1.9087e+006
22	0.0010815	47	0.0010765	72	0.00057103	97	0.0012572	122	0.00024222
23	0.0011911	48	0.0008321	73	0.0018604	98	0.00091268	123	0.030151
24	0.0023571	49	0.0028508	74	0.0060804	99	0.07285	124	0.89065
25	0.0053013	50	0.0068315	75	0.040095	100	0.42455	125	1.4102

Random Input Response

Table C.30: *Orthogonal Collocation (m=1) - Random Input Response*

p	Error	p	Error	p	Error	p	Error	p	Error
1	0.038446	26	0.038516	51	0.040299	76	0.14628	101	0.96391
2	0.020621	27	0.020622	52	0.021527	77	0.14684	102	0.96733
3	0.002679	28	0.0023562	53	0.0027629	78	0.14786	103	0.96872
4	0.000403	29	0.00090223	54	0.0010334	79	0.14837	104	0.97016
5	0.000944	30	0.00045221	55	0.0007026	80	0.14801	105	0.96957
6	0.027631	31	0.02776	56	0.032108	81	0.38127	106	2.2526
7	0.016515	32	0.016597	57	0.019161	82	0.38235	107	2.2569
8	0.002313	33	0.0020889	58	0.0024221	83	0.3843	108	2.2663
9	0.000894	34	0.00056629	59	0.00062762	84	0.3837	109	2.2645
10	0.001207	35	0.00057548	60	0.00035218	85	0.38374	110	2.2649
11	0.012568	36	0.012711	61	0.019183	86	0.66843	111	3.5296
12	0.008526	37	0.0086402	62	0.013147	87	0.66968	112	3.5418
13	0.001174	38	0.0011409	63	0.0017154	88	0.67173	113	3.5505
14	0.000735	39	0.00058673	64	0.00084995	89	0.67164	114	3.5535
15	0.000708	40	0.00044782	65	0.00068144	90	0.6724	115	3.5532
16	0.003638	41	0.003773	66	0.010577	91	0.86707	116	4.3117
17	0.002545	42	0.0026444	67	0.0076528	92	0.86543	117	4.3266
18	0.000428	43	0.00060243	68	0.0037789	93	0.86861	118	4.3203
19	0.000633	44	0.00054827	69	0.0035636	94	0.8695	119	4.3252
20	0.000629	45	0.00050087	70	0.0039935	95	0.86941	120	4.3262
21	0.000673	46	0.0008142	71	0.0099375	96	0.9611	121	4.6684
22	0.000504	47	0.00065113	72	0.0095771	97	0.96156	122	4.6671
23	0.000271	48	0.00027363	73	0.0096409	98	0.96241	123	4.6663
24	0.000535	49	0.00053137	74	0.0097	99	0.96327	124	4.6706
25	0.000721	50	0.0007625	75	0.0097705	100	0.96313	125	4.6682

Table C.31: *Orthogonal Collocation (m=2) - Random Input Response*

p	Error	p	Error	p	Error	p	Error	p	Error
1	0.016325	26	0.016822	51	0.017598	76	0.022852	101	0.34513
2	0.008073	27	0.0081683	52	0.0081051	77	0.011408	102	0.34592
3	0.000611	28	0.00071648	53	0.00054082	78	0.00095326	103	0.34708
4	0.000527	29	0.0010601	54	0.00082529	79	0.00093846	104	0.34745
5	0.000554	30	0.00040847	55	0.00063894	80	0.00039879	105	0.3471
6	0.006371	31	0.0063897	56	0.0073494	81	0.017952	106	0.62655
7	0.003194	32	0.0032376	57	0.0037187	82	0.012847	107	0.62803
8	0.000597	33	0.00061692	58	0.00032356	83	0.012093	108	0.63065
9	0.000998	34	0.00057016	59	0.00077666	84	0.011734	109	0.63062
10	0.000897	35	0.00075662	60	0.00041364	85	0.011811	110	0.63057
11	0.001461	36	0.0015517	61	0.0023469	86	0.033553	111	0.80461
12	0.000756	37	0.00076136	62	0.0011374	87	0.033418	112	0.80355
13	0.000371	38	0.00034584	63	0.00036087	88	0.033661	113	0.80624
14	0.000613	39	0.0006462	64	0.00068626	89	0.033581	114	0.80711
15	0.000512	40	0.00048622	65	0.00055779	90	0.034136	115	0.80721
16	0.000298	41	0.0003264	66	0.00084703	91	0.049781	116	0.8827
17	0.000315	42	0.00020212	67	0.00036537	92	0.049823	117	0.88306
18	0.000229	43	0.00029236	68	0.00039155	93	0.050044	118	0.8831
19	0.000336	44	0.0004782	69	0.00032335	94	0.050068	119	0.8834
20	0.000544	45	0.00044551	70	0.00041149	95	0.050015	120	0.88386
21	0.000142	46	0.00015113	71	0.00026734	96	0.057802	121	0.91379
22	0.000136	47	0.0001669	72	0.00016635	97	0.057616	122	0.91428
23	0.000282	48	0.00023828	73	0.00017342	98	0.057736	123	0.91261
24	0.000527	49	0.00063004	74	0.00025441	99	0.057811	124	0.91071
25	0.000709	50	0.0007008	75	0.00032627	100	0.057808	125	0.91276

Table C.32: *Orthogonal Collocation (m=3) - Random Input Response*

p	Error	p	Error	p	Error	p	Error	p	Error
1	0.005756	26	0.0057174	51	0.0060281	76	0.0086579	101	0.064185
2	0.002254	27	0.002247	52	0.0023759	77	0.0031174	102	0.064889
3	0.000273	28	0.00051223	53	0.00040757	78	0.00044638	103	0.064977
4	0.000544	29	0.00096218	54	0.00073456	79	0.00061578	104	0.065135
5	0.000568	30	0.00041161	55	0.00057209	80	0.00051586	105	0.064792
6	0.001369	31	0.00078583	56	0.0011186	81	0.0033273	106	0.13177
7	0.000353	32	0.00041947	57	0.00048394	82	0.0012443	107	0.13136
8	0.000581	33	0.00059723	58	0.0003499	83	0.00040868	108	0.13208
9	0.000962	34	0.00054061	59	0.00064981	84	0.00072791	109	0.13221
10	0.000970	35	0.00072783	60	0.00042184	85	0.0007594	110	0.13206
11	0.000255	36	0.00025892	61	0.00043176	86	0.0014474	111	0.17215
12	0.000150	37	0.00013949	62	0.00021304	87	0.00062861	112	0.17116
13	0.000339	38	0.00032283	63	0.0003697	88	0.00029784	113	0.17242
14	0.000607	39	0.00055147	64	0.00058697	89	0.00045401	114	0.1728
15	0.000547	40	0.00044011	65	0.00049749	90	0.00038569	115	0.17275
16	0.000091	41	0.0001201	66	0.0001154	91	0.00096163	116	0.18961
17	0.000278	42	0.00015019	67	0.00011614	92	0.00073687	117	0.18869
18	0.000221	43	0.00028598	68	0.00031865	93	0.00083478	118	0.18977
19	0.000365	44	0.00048607	69	0.00031637	94	0.0008908	119	0.18982
20	0.000593	45	0.00045451	70	0.00041206	95	0.001004	120	0.18989
21	0.000141	46	0.00014525	71	8.17E-05	96	0.0013623	121	0.19774
22	0.000139	47	0.00017042	72	0.0001033	97	0.001334	122	0.19654
23	0.000264	48	0.00023951	73	0.00018209	98	0.001477	123	0.19567
24	0.000535	49	0.00063947	74	0.00023866	99	0.0018506	124	0.19601
25	0.000542	50	0.00076318	75	0.00035702	100	0.0018786	125	0.19612

Table C.33: *Orthogonal Collocation (m=4) - Random Input Response*

p	Error	p	Error	p	Error	p	Error	p	Error
1	0.001583	26	0.0011707	51	0.0012577	76	0.0023212	101	0.004688
2	0.000443	27	0.000437	52	0.00042493	77	0.00069445	102	0.0022482
3	0.000297	28	0.00047959	53	0.00038388	78	0.00041097	103	0.0014824
4	0.000456	29	0.00099168	54	0.00072474	79	0.00056922	104	0.0017085
5	0.000602	30	0.00038738	55	0.00057766	80	0.00043879	105	0.0013782
6	0.000340	31	0.0004165	56	0.00041914	81	0.00089582	106	0.015145
7	0.000156	32	0.00017576	57	0.00015927	82	0.00020332	107	0.015635
8	0.000518	33	0.00057862	58	0.00031247	83	0.00030269	108	0.015615
9	0.001009	34	0.00054374	59	0.0006088	84	0.00029527	109	0.015572
10	0.000979	35	0.00076502	60	0.00038824	85	0.00049924	110	0.015509
11	0.000085	36	0.0001278	61	0.00011809	86	0.00026477	111	0.02636
12	0.000121	37	0.00012573	62	0.00014373	87	0.00018159	112	0.026628
13	0.000319	38	0.00031573	63	0.00041113	88	0.00027787	113	0.026427
14	0.000622	39	0.00056433	64	0.00061164	89	0.00038841	114	0.026554
15	0.000521	40	0.00042256	65	0.00050316	90	0.0004237	115	0.026602
16	0.000079	41	0.00011765	66	8.85E-05	91	0.00012774	116	0.031297
17	0.000286	42	0.00013866	67	0.00011584	92	0.0002027	117	0.031664
18	0.000211	43	0.00029338	68	0.00033062	93	0.00039799	118	0.031114
19	0.000383	44	0.00046591	69	0.00031012	94	0.00052867	119	0.031379
20	0.000596	45	0.00041571	70	0.00046542	95	0.00071424	120	0.031423
21	0.000145	46	0.00014952	71	7.84E-05	96	0.00028785	121	0.033618
22	0.000136	47	0.00017747	72	0.00010574	97	0.00047649	122	0.033619
23	0.000262	48	0.00024341	73	0.00017715	98	0.00079125	123	0.03355
24	0.000519	49	0.00061741	74	0.00024962	99	0.0012933	124	0.033459
25	0.000781	50	0.00073868	75	0.00036229	100	0.001317	125	0.033102

Table C.34: *Orthogonal Collocation (m=5) - Random Input Response*

p	Error	p	Error	p	Error	p	Error	p	Error
1	0.000545	26	0.00073207	51	0.00060797	76	0.00101	101	0.0022234
2	0.000108	27	0.00021043	52	0.00015263	77	0.0002879	102	0.0016539
3	0.000302	28	0.00048136	53	0.0003842	78	0.00034715	103	0.0014884
4	0.000490	29	0.00091109	54	0.00069622	79	0.00057627	104	0.0014574
5	0.000584	30	0.0003874	55	0.00058694	80	0.0004778	105	0.0016757
6	0.000131	31	0.00019526	56	0.00011932	81	0.00027234	106	0.00086937
7	0.000130	32	0.00016215	57	0.00014583	82	0.00014379	107	0.0003452
8	0.000595	33	0.00062172	58	0.00037139	83	0.00031443	108	0.00033311
9	0.000928	34	0.00052446	59	0.00065756	84	0.00034736	109	0.00033806
10	0.001039	35	0.00071973	60	0.00033276	85	0.00047258	110	0.00055764
11	0.000089	36	0.0001084	61	9.91E-05	86	8.10E-05	111	0.0021688
12	0.000121	37	0.00010782	62	0.00011123	87	0.00011755	112	0.0022214
13	0.000367	38	0.0003245	63	0.00040564	88	0.00031327	113	0.0020666
14	0.000610	39	0.00058169	64	0.00060603	89	0.00038625	114	0.0022048
15	0.000534	40	0.00045324	65	0.00049843	90	0.00038805	115	0.0022425
16	0.000076	41	0.00011749	66	8.41E-05	91	0.00021639	116	0.003306
17	0.000287	42	0.00014618	67	0.00010589	92	0.00016254	117	0.0034244
18	0.000221	43	0.00031643	68	0.00036794	93	0.00033935	118	0.0034313
19	0.000363	44	0.00049481	69	0.00033586	94	0.00054181	119	0.0032136
20	0.000534	45	0.00044719	70	0.00043357	95	0.00075882	120	0.0035679
21	0.000140	46	0.00014834	71	8.15E-05	96	0.00026491	121	0.0038422
22	0.000143	47	0.0001767	72	9.88E-05	97	0.00048694	122	0.0040662
23	0.000246	48	0.00023454	73	0.00016159	98	0.00082954	123	0.0036392
24	0.000527	49	0.00061182	74	0.00024707	99	0.0012749	124	0.0042794
25	0.000680	50	0.00071074	75	0.00033145	100	0.0012744	125	0.0041638

Table C.35: *Orthogonal Collocation (m=6) - Random Input Response*

p	Error	p	Error	p	Error	p	Error	p	Error
1	0.000260	26	0.0002387	51	0.00025162	76	0.00038033	101	0.00051823
2	0.000127	27	0.00019574	52	0.0001373	77	0.00022757	102	0.00023263
3	0.000304	28	0.00047404	53	0.00038963	78	0.00035155	103	0.00025702
4	0.000523	29	0.0009081	54	0.0006896	79	0.00055789	104	0.00034584
5	0.000614	30	0.00041051	55	0.00054414	80	0.00041682	105	0.0004674
6	0.000082	31	0.00012845	56	4.91E-05	81	0.00016543	106	0.0003793
7	0.000134	32	0.00015758	57	0.00016742	82	0.00012024	107	0.0002935
8	0.000521	33	0.00059276	58	0.00032622	83	0.00031749	108	0.00050898
9	0.000973	34	0.00053124	59	0.00068408	84	0.00033367	109	0.00050456
10	0.001001	35	0.00073994	60	0.00033103	85	0.00054554	110	0.00065126
11	0.000094	36	0.0001056	61	0.00010401	86	0.00010688	111	0.00015324
12	0.000124	37	0.00011106	62	0.00011538	87	0.00010814	112	0.00026438
13	0.000366	38	0.00031722	63	0.00038088	88	0.00030476	113	0.00043286
14	0.000612	39	0.00055393	64	0.00064357	89	0.00039317	114	0.00059942
15	0.000538	40	0.00044139	65	0.00048473	90	0.00042071	115	0.00059889
16	0.000082	41	0.000117	66	8.36E-05	91	0.0001551	116	0.0003567
17	0.000273	42	0.00014963	67	0.00010685	92	0.00018236	117	0.00040029
18	0.000223	43	0.0002895	68	0.00033641	93	0.00035292	118	0.00078454
19	0.000360	44	0.00049045	69	0.00028533	94	0.00055149	119	0.0010818
20	0.000583	45	0.0004504	70	0.0004265	95	0.00071253	120	0.0011983
21	0.000143	46	0.00014368	71	7.64E-05	96	0.00028295	121	0.00081841
22	0.000138	47	0.00017684	72	0.00010968	97	0.00039572	122	0.00085228
23	0.000270	48	0.00023613	73	0.00018731	98	0.00076278	123	0.0017553
24	0.000529	49	0.00065531	74	0.00024795	99	0.0011669	124	0.0020446
25	0.000695	50	0.00069576	75	0.00035025	100	0.00127	125	0.0021269

Table C.36: *Galerkin (m=1) - Random Input Response*

p	Error	p	Error	p	Error	p	Error	p	Error
1	0.038446	26	0.038512	51	0.040297	76	0.16848	101	1.0132
2	0.020617	27	0.020597	52	0.021529	77	0.16791	102	1.0132
3	0.002648	28	0.0023583	53	0.0027393	78	0.16863	103	1.0148
4	0.000525	29	0.00091784	54	0.00081682	79	0.16934	104	1.0164
5	0.000577	30	0.00048004	55	0.00062886	80	0.16915	105	1.0159
6	0.027631	31	0.027761	56	0.032073	81	0.42467	106	2.3819
7	0.016516	32	0.016596	57	0.019012	82	0.42585	107	2.382
8	0.002267	33	0.002092	58	0.0024671	83	0.42741	108	2.3914
9	0.001129	34	0.00065381	59	0.0010891	84	0.42684	109	2.3894
10	0.001072	35	0.00084532	60	0.00055643	85	0.42713	110	2.3892
11	0.012568	36	0.012711	61	0.01914	86	0.71572	111	3.6787
12	0.008612	37	0.0086401	62	0.013005	87	0.71697	112	3.6909
13	0.001177	38	0.0011467	63	0.0019714	88	0.71888	113	3.6996
14	0.000840	39	0.00074417	64	0.0013133	89	0.71852	114	3.7025
15	0.000738	40	0.00055642	65	0.0010939	90	0.71925	115	3.7029
16	0.003638	41	0.0037731	66	0.011057	91	0.89532	116	4.3848
17	0.002547	42	0.0027945	67	0.0082249	92	0.89503	117	4.4165
18	0.000393	43	0.00054746	68	0.0051924	93	0.89673	118	4.4101
19	0.000502	44	0.00056073	69	0.0049522	94	0.89751	119	4.4146
20	0.000630	45	0.00046083	70	0.0053748	95	0.89759	120	4.4158
21	0.000674	46	0.00081281	71	0.010866	96	0.97181	121	4.7025
22	0.000498	47	0.00065402	72	0.010614	97	0.97224	122	4.7011
23	0.000358	48	0.00027615	73	0.010695	98	0.97319	123	4.7002
24	0.000728	49	0.0007093	74	0.010722	99	0.97396	124	4.7046
25	0.000832	50	0.00099239	75	0.010824	100	0.9739	125	4.7021

Table C.37: *Galerkin (m=2) - Random Input Response*

p	Error	p	Error	p	Error	p	Error	p	Error
1	0.016324	26	0.016822	51	0.017597	76	0.023866	101	0.39604
2	0.008073	27	0.0081663	52	0.0081032	77	0.012903	102	0.39677
3	0.000627	28	0.00071719	53	0.00053021	78	0.0076979	103	0.39768
4	0.000509	29	0.0010558	54	0.00078548	79	0.0081326	104	0.39795
5	0.000601	30	0.00040741	55	0.00063648	80	0.0076734	105	0.39743
6	0.006370	31	0.0063896	56	0.0073477	81	0.02572	106	0.68114
7	0.003195	32	0.0032375	57	0.0037172	82	0.023764	107	0.68091
8	0.000630	33	0.00059782	58	0.0003517	83	0.024179	108	0.68354
9	0.000956	34	0.00057018	59	0.00074337	84	0.023713	109	0.68332
10	0.000927	35	0.0007393	60	0.00038678	85	0.023844	110	0.68329
11	0.001461	36	0.0015521	61	0.0023443	86	0.042868	111	0.83445
12	0.000756	37	0.0007632	62	0.0011353	87	0.042623	112	0.83315
13	0.000355	38	0.00034416	63	0.00037863	88	0.042902	113	0.83555
14	0.000617	39	0.00059872	64	0.00064995	89	0.042861	114	0.83677
15	0.000550	40	0.00051363	65	0.00042752	90	0.043295	115	0.83673
16	0.000298	41	0.00032503	66	0.0008092	91	0.054152	116	0.89481
17	0.000311	42	0.00020896	67	0.00043596	92	0.054164	117	0.89511
18	0.000229	43	0.0002765	68	0.00035801	93	0.054374	118	0.89518
19	0.000407	44	0.0004915	69	0.00032333	94	0.054458	119	0.89565
20	0.000609	45	0.0004344	70	0.00040231	95	0.054371	120	0.89594
21	0.000143	46	0.00015084	71	0.00026555	96	0.059289	121	0.91769
22	0.000140	47	0.0001828	72	0.00016877	97	0.059177	122	0.918
23	0.000267	48	0.00025091	73	0.00017495	98	0.059314	123	0.91654
24	0.000549	49	0.00057833	74	0.0002234	99	0.059174	124	0.9175
25	0.000677	50	0.00075749	75	0.00035206	100	0.059314	125	0.91664

Table C.38: *Orthogonal Collocation ($m=1$) - Random Input Response Divided by Stationary Solution*

p	Error	p	Error	p	Error	p	Error	p	Error
1	0.038446	26	0.038513	51	0.040296	76	0.040792	101	0.0092367
2	0.020621	27	0.020622	52	0.021521	77	0.016202	102	0.0203
3	0.002679	28	0.0023562	53	0.0027591	78	0.0020992	103	0.022968
4	0.000403	29	0.00090223	54	0.0010308	79	0.0031797	104	0.017808
5	0.000944	30	0.00045221	55	0.00071106	80	0.0032751	105	0.016831
6	0.027631	31	0.02776	56	0.032095	81	0.0355	106	0.0079351
7	0.016515	32	0.016598	57	0.019164	82	0.012652	107	0.037475
8	0.002313	33	0.0020889	58	0.0023188	83	0.0091173	108	0.05041
9	0.000894	34	0.00056649	59	0.00060363	84	0.0091911	109	0.042446
10	0.001207	35	0.0005756	60	0.00037845	85	0.0092744	110	0.041362
11	0.012568	36	0.01271	61	0.019163	86	0.021902	111	0.0094139
12	0.008526	37	0.0086402	62	0.01298	87	0.0043939	112	0.033799
13	0.001174	38	0.0011411	63	0.0016543	88	0.020843	113	0.064555
14	0.000735	39	0.00058691	64	0.0006289	89	0.02107	114	0.06551
15	0.000708	40	0.00044778	65	0.00067429	90	0.020779	115	0.065002
16	0.003638	41	0.0037731	66	0.010288	91	0.011895	116	0.0060371
17	0.002545	42	0.0026455	67	0.0071708	92	0.0023025	117	0.023145
18	0.000428	43	0.00060305	68	0.0011265	93	0.024954	118	0.055338
19	0.000633	44	0.0005483	69	0.00034085	94	0.029652	119	0.066641
20	0.000629	45	0.00050088	70	0.00055061	95	0.029816	120	0.067513
21	0.000673	46	0.00082827	71	0.0053881	96	0.0055392	121	0.0025309
22	0.000504	47	0.00065144	72	0.0039384	97	0.0016199	122	0.011795
23	0.000271	48	0.0002734	73	0.00072557	98	0.016827	123	0.033842
24	0.000535	49	0.00053089	74	0.00049796	99	0.024242	124	0.045311
25	0.000721	50	0.00076244	75	0.00051124	100	0.025512	125	0.034723

Table C.39: *Orthogonal Collocation ($m=2$) - Random Input Response Divided by Stationary Solution*

p	Error	p	Error	p	Error	p	Error	p	Error
1	0.016325	26	0.016822	51	0.017609	76	0.022459	101	0.017029
2	0.008073	27	0.0081683	52	0.0081051	77	0.011406	102	0.0047244
3	0.000611	28	0.00071648	53	0.00054083	78	0.00097779	103	0.010406
4	0.000527	29	0.0010601	54	0.00081975	79	0.00083593	104	0.0086528
5	0.000554	30	0.00040914	55	0.00063934	80	0.00035688	105	0.0081842
6	0.006371	31	0.0063897	56	0.0073296	81	0.015206	106	0.0069557
7	0.003194	32	0.0032376	57	0.0036915	82	0.0079309	107	0.0097966
8	0.000597	33	0.00061692	58	0.0003405	83	0.0010946	108	0.022537
9	0.000998	34	0.00057016	59	0.00077654	84	0.0006158	109	0.020622
10	0.000897	35	0.00075662	60	0.00041329	85	0.00087925	110	0.020328
11	0.001461	36	0.0015481	61	0.0023232	86	0.0088866	111	0.002586
12	0.000756	37	0.00076136	62	0.0011487	87	0.0048356	112	0.0083577
13	0.000371	38	0.00034308	63	0.00036201	88	0.0012607	113	0.025162
14	0.000613	39	0.00064629	64	0.00068545	89	0.001595	114	0.028251
15	0.000512	40	0.0004862	65	0.00055741	90	0.0017494	115	0.028313
16	0.000298	41	0.00032919	66	0.00088942	91	0.0045839	116	0.010271
17	0.000316	42	0.0002036	67	0.00046477	92	0.0025238	117	0.0049336
18	0.000229	43	0.0002928	68	0.00038173	93	0.0015397	118	0.017076
19	0.000336	44	0.00047804	69	0.00032617	94	0.002495	119	0.023403
20	0.000544	45	0.00044563	70	0.00041171	95	0.0025635	120	0.024109
21	0.000142	46	0.00015208	71	0.00028471	96	0.0020333	121	0.0010225
22	0.000137	47	0.00016724	72	0.00017475	97	0.0012652	122	0.0022569
23	0.000282	48	0.00023755	73	0.00019521	98	0.0012255	123	0.0098411
24	0.000527	49	0.00063004	74	0.00026415	99	0.0021878	124	0.013642
25	0.000709	50	0.00070083	75	0.00032916	100	0.0022462	125	0.01281

Table C.40: *Orthogonal Collocation ($m=3$) - Random Input Response Divided by Stationary Solution*

p	Error	p	Error	p	Error	p	Error	p	Error
1	0.005756	26	0.0057174	51	0.0059981	76	0.0084383	101	0.012423
2	0.002254	27	0.002247	52	0.0023782	77	0.0031872	102	0.0048261
3	0.000273	28	0.00051223	53	0.00040757	78	0.00041709	103	0.0024862
4	0.000544	29	0.00096218	54	0.00073243	79	0.00065318	104	0.0024124
5	0.000568	30	0.00041161	55	0.00057293	80	0.00049375	105	0.0021621
6	0.001369	31	0.00078583	56	0.0011168	81	0.0031152	106	0.0065635
7	0.000353	32	0.00041947	57	0.00047773	82	0.0012108	107	0.0028379
8	0.000581	33	0.00059723	58	0.00034622	83	0.00028992	108	0.0058046
9	0.000962	34	0.00054061	59	0.00065393	84	0.00029534	109	0.0057653
10	0.000970	35	0.00072783	60	0.00042209	85	0.00047141	110	0.0057205
11	0.000255	36	0.00025892	61	0.00042125	86	0.0016922	111	0.0029547
12	0.000150	37	0.00013949	62	0.0001963	87	0.00051784	112	0.001612
13	0.000339	38	0.00032283	63	0.00036788	88	0.00022731	113	0.0062552
14	0.000607	39	0.00055147	64	0.00058723	89	0.00034903	114	0.0077449
15	0.000547	40	0.00044011	65	0.00049712	90	0.00048326	115	0.0077335
16	0.000091	41	0.0001201	66	0.00012675	91	0.00061839	116	0.001331
17	0.000278	42	0.00015113	67	0.00012196	92	0.00030269	117	0.00078704
18	0.000221	43	0.00028632	68	0.0003278	93	0.00038331	118	0.0040981
19	0.000365	44	0.00048611	69	0.00031642	94	0.00056121	119	0.0058444
20	0.000593	45	0.00045438	70	0.00041342	95	0.00077373	120	0.0060681
21	0.000141	46	0.00014659	71	7.38E-05	96	0.00038438	121	0.00115
22	0.000139	47	0.00016507	72	9.68E-05	97	0.00044797	122	0.00098896
23	0.000264	48	0.00024032	73	0.00019657	98	0.00091998	123	0.0025439
24	0.000535	49	0.00063799	74	0.00024508	99	0.00136	124	0.0037146
25	0.000542	50	0.0007633	75	0.0003579	100	0.0014048	125	0.0032807

Table C.41: *Orthogonal Collocation ($m=4$) - Random Input Response Divided by Stationary Solution*

p	Error	p	Error	p	Error	p	Error	p	Error
1	0.001583	26	0.0011707	51	0.0012578	76	0.0022945	101	0.004896
2	0.000443	27	0.000437	52	0.00042493	77	0.00072393	102	0.0019187
3	0.000297	28	0.00047959	53	0.00038388	78	0.00041047	103	0.00066605
4	0.000456	29	0.00099168	54	0.00072474	79	0.00056948	104	0.00072206
5	0.000602	30	0.00038738	55	0.00058154	80	0.00044334	105	0.00051007
6	0.000340	31	0.0004165	56	0.00041915	81	0.00091068	106	0.00271
7	0.000156	32	0.00017576	57	0.00015365	82	0.0002364	107	0.0015202
8	0.000518	33	0.00057862	58	0.00030972	83	0.00037167	108	0.00095204
9	0.001009	34	0.00054439	59	0.00061144	84	0.00030886	109	0.001024
10	0.000979	35	0.00076502	60	0.0003869	85	0.00051422	110	0.0010908
11	0.000085	36	0.0001278	61	0.00010797	86	0.00027905	111	0.0010559
12	0.000121	37	0.00012573	62	0.00013155	87	0.00013806	112	0.0007406
13	0.000319	38	0.00031624	63	0.00039475	88	0.00024634	113	0.0010822
14	0.000622	39	0.00056432	64	0.00065781	89	0.00037836	114	0.0014392
15	0.000521	40	0.00042246	65	0.0005033	90	0.00044256	115	0.0014718
16	0.000079	41	0.00011752	66	8.70E-05	91	0.00012962	116	0.00061253
17	0.000284	42	0.00013846	67	0.00011751	92	0.00019214	117	0.00052365
18	0.000211	43	0.00029543	68	0.00033291	93	0.00038113	118	0.0010476
19	0.000383	44	0.00046592	69	0.00031073	94	0.00055248	119	0.0015854
20	0.000596	45	0.00041571	70	0.00046553	95	0.00072195	120	0.0015836
21	0.000145	46	0.00014802	71	7.14E-05	96	0.00032624	121	0.0010527
22	0.000136	47	0.00017565	72	9.73E-05	97	0.00043874	122	0.00103
23	0.000263	48	0.00024446	73	0.00018041	98	0.00089392	123	0.0016371
24	0.000519	49	0.0006173	74	0.00025956	99	0.0012882	124	0.0021746
25	0.000781	50	0.00073867	75	0.00036515	100	0.0013808	125	0.0017255

Table C.42: *Orthogonal Collocation ($m=5$) - Random Input Response Divided by Stationary Solution*

p	Error	p	Error	p	Error	p	Error	p	Error
1	0.000545	26	0.00073207	51	0.00064311	76	0.00093392	101	0.0014768
2	0.000108	27	0.00021043	52	0.00015263	77	0.00027962	102	0.0003382
3	0.000302	28	0.00048136	53	0.00038301	78	0.00034704	103	0.00025545
4	0.000490	29	0.00091109	54	0.00069622	79	0.00057629	104	0.00031616
5	0.000584	30	0.0003874	55	0.00058694	80	0.00047564	105	0.00039592
6	0.000131	31	0.00019526	56	0.00011932	81	0.0002489	106	0.00066447
7	0.000130	32	0.00016215	57	0.00014428	82	0.00012445	107	0.00027089
8	0.000595	33	0.00062172	58	0.00037057	83	0.00030177	108	0.00031615
9	0.000928	34	0.00052446	59	0.00065815	84	0.00034554	109	0.00035831
10	0.001039	35	0.00071973	60	0.00033234	85	0.00047612	110	0.00053967
11	0.000089	36	0.0001084	61	0.00010354	86	8.46E-05	111	0.00031035
12	0.000121	37	0.00010688	62	0.00011903	87	0.00010452	112	0.00030217
13	0.000367	38	0.0003245	63	0.00039822	88	0.00025005	113	0.00044815
14	0.000610	39	0.00058169	64	0.00060549	89	0.00038065	114	0.00068083
15	0.000534	40	0.00045325	65	0.00049747	90	0.00042218	115	0.00069
16	0.000076	41	0.00011748	66	8.52E-05	91	0.00013955	116	0.00028638
17	0.000290	42	0.00014735	67	0.00010568	92	0.00018736	117	0.00042814
18	0.000221	43	0.00031653	68	0.00036216	93	0.0003817	118	0.0010022
19	0.000363	44	0.00049497	69	0.00032765	94	0.00054248	119	0.0011965
20	0.000534	45	0.0004472	70	0.00043519	95	0.00074622	120	0.001204
21	0.000140	46	0.00015144	71	8.36E-05	96	0.00032642	121	0.0010245
22	0.000143	47	0.00017704	72	0.00010254	97	0.00043322	122	0.0010082
23	0.000247	48	0.00023438	73	0.00017973	98	0.00089025	123	0.00169
24	0.000527	49	0.00060543	74	0.00024827	99	0.0013204	124	0.0022187
25	0.000680	50	0.00071061	75	0.00033214	100	0.0014663	125	0.0020148

Table C.43: *Orthogonal Collocation ($m=6$) - Random Input Response Divided by Stationary Solution*

p	Error	p	Error	p	Error	p	Error	p	Error
1	0.000260	26	0.0002387	51	0.00025163	76	0.00038029	101	0.00049916
2	0.000127	27	0.00019574	52	0.0001373	77	0.00020748	102	0.00017269
3	0.000304	28	0.00047404	53	0.00038963	78	0.00035158	103	0.00026416
4	0.000523	29	0.0009081	54	0.00068875	79	0.00056331	104	0.00040362
5	0.000614	30	0.00041073	55	0.00054414	80	0.00041618	105	0.00042958
6	0.000082	31	0.00012845	56	4.91E-05	81	0.00013449	106	0.00017156
7	0.000134	32	0.00015758	57	0.00016741	82	0.0001242	107	0.000137
8	0.000521	33	0.00059276	58	0.00031846	83	0.00031684	108	0.00023272
9	0.000973	34	0.00053124	59	0.00068364	84	0.00034163	109	0.00038179
10	0.001001	35	0.00073994	60	0.00033017	85	0.00053816	110	0.00053494
11	0.000094	36	0.0001056	61	0.00010168	86	7.96E-05	111	0.00013895
12	0.000124	37	0.00011106	62	0.00011764	87	9.34E-05	112	0.00027633
13	0.000366	38	0.00031679	63	0.00037023	88	0.00023342	113	0.00045437
14	0.000612	39	0.00055393	64	0.00064183	89	0.00039428	114	0.00061362
15	0.000538	40	0.00044137	65	0.00048122	90	0.00044579	115	0.00063567
16	0.000082	41	0.000117	66	8.25E-05	91	0.00013071	116	0.00027559
17	0.000273	42	0.00014917	67	0.00010585	92	0.00017982	117	0.00042612
18	0.000223	43	0.00028988	68	0.00034377	93	0.00038812	118	0.0010388
19	0.000360	44	0.00049026	69	0.00028419	94	0.00054379	119	0.0011949
20	0.000583	45	0.00045043	70	0.00042745	95	0.00071779	120	0.0012079
21	0.000143	46	0.00014451	71	7.26E-05	96	0.00033565	121	0.0010299
22	0.000138	47	0.00017653	72	0.00010567	97	0.00042907	122	0.0010124
23	0.000270	48	0.0002361	73	0.00020345	98	0.0009066	123	0.0017219
24	0.000529	49	0.00065544	74	0.00024665	99	0.0012697	124	0.0021494
25	0.000695	50	0.00069577	75	0.00035194	100	0.0012347	125	0.0020331

Table C.44: *Galerkin (m=1) - Random Input Response Divided by Stationary Solution*

p	Error	p	Error	p	Error	p	Error	p	Error
1	0.038446	26	0.038512	51	0.040289	76	0.037785	101	0.0072345
2	0.020617	27	0.020597	52	0.021508	77	0.016011	102	0.021741
3	0.002648	28	0.0023583	53	0.0027198	78	0.0023376	103	0.023778
4	0.000525	29	0.00091784	54	0.00082121	79	0.0034402	104	0.018198
5	0.000577	30	0.00048004	55	0.00059646	80	0.0035502	105	0.017428
6	0.027631	31	0.027761	56	0.032074	81	0.032416	106	0.0091112
7	0.016516	32	0.016596	57	0.019145	82	0.0096084	107	0.03976
8	0.002267	33	0.002092	58	0.0023898	83	0.010432	108	0.051981
9	0.001129	34	0.00065322	59	0.00080191	84	0.010056	109	0.043678
10	0.001072	35	0.00084532	60	0.00046967	85	0.010054	110	0.04248
11	0.012568	36	0.01271	61	0.019124	86	0.019735	111	0.010537
12	0.008612	37	0.0086417	62	0.012949	87	0.0019539	112	0.035522
13	0.001177	38	0.0011467	63	0.0016386	88	0.022216	113	0.065956
14	0.000840	39	0.00074351	64	0.00057652	89	0.022302	114	0.06686
15	0.000738	40	0.00055641	65	0.00052136	90	0.021968	115	0.066325
16	0.003638	41	0.0037731	66	0.010218	91	0.011129	116	0.0065556
17	0.002547	42	0.0027953	67	0.0071287	92	0.0023831	117	0.023801
18	0.000394	43	0.00054743	68	0.0011155	93	0.025852	118	0.056334
19	0.000502	44	0.00056077	69	0.00032679	94	0.030344	119	0.067518
20	0.000630	45	0.00046085	70	0.00051753	95	0.030524	120	0.068403
21	0.000674	46	0.00081785	71	0.0053471	96	0.0054082	121	0.0025726
22	0.000498	47	0.00065073	72	0.0038644	97	0.0015986	122	0.011924
23	0.000358	48	0.00027601	73	0.00067714	98	0.017054	123	0.034067
24	0.000728	49	0.00070916	74	0.00053294	99	0.024531	124	0.045509
25	0.000832	50	0.0009924	75	0.00054958	100	0.025752	125	0.034896

Table C.45: *Galerkin (m=2) - Random Input Response Divided by Stationary Solution*

p	Error	p	Error	p	Error	p	Error	p	Error
1	0.016324	26	0.016822	51	0.017608	76	0.022493	101	0.012989
2	0.008073	27	0.0081663	52	0.0081032	77	0.010732	102	0.0060422
3	0.000627	28	0.00071719	53	0.00053021	78	0.00070057	103	0.01195
4	0.000509	29	0.0010558	54	0.0007858	79	0.00062438	104	0.0096451
5	0.000601	30	0.00040741	55	0.00063631	80	0.00048378	105	0.0091897
6	0.006370	31	0.0063896	56	0.0073279	81	0.014524	106	0.0042743
7	0.003195	32	0.0032375	57	0.0036893	82	0.0071771	107	0.011188
8	0.000630	33	0.00059782	58	0.00036087	83	0.00077811	108	0.024008
9	0.000956	34	0.00057018	59	0.00074378	84	0.00072632	109	0.022084
10	0.000927	35	0.0007393	60	0.00038659	85	0.0010267	110	0.021684
11	0.001461	36	0.0015485	61	0.0023296	86	0.0083215	111	0.0014534
12	0.000756	37	0.00076533	62	0.0011474	87	0.0040977	112	0.0087752
13	0.000355	38	0.00034464	63	0.00037391	88	0.0013029	113	0.026044
14	0.000617	39	0.00059904	64	0.00065136	89	0.0019283	114	0.0291
15	0.000550	40	0.0005136	65	0.00042771	90	0.0020145	115	0.029083
16	0.000298	41	0.00033007	66	0.00088652	91	0.0045459	116	0.0007413
17	0.000311	42	0.00021091	67	0.00047371	92	0.0022773	117	0.0051374
18	0.000229	43	0.0002764	68	0.00035921	93	0.0015601	118	0.01732
19	0.000407	44	0.00049156	69	0.00032029	94	0.0026438	119	0.023703
20	0.000609	45	0.00043437	70	0.00040207	95	0.0026369	120	0.024454
21	0.000143	46	0.00015044	71	0.00029169	96	0.0020377	121	0.0010112
22	0.000139	47	0.00018338	72	0.00018325	97	0.00125	122	0.0022684
23	0.000267	48	0.00025115	73	0.00018957	98	0.001247	123	0.0096795
24	0.000549	49	0.00057797	74	0.00022183	99	0.0021297	124	0.013689
25	0.000677	50	0.00075762	75	0.00035337	100	0.0021554	125	0.013022

Appendix D

Figures

Steady State

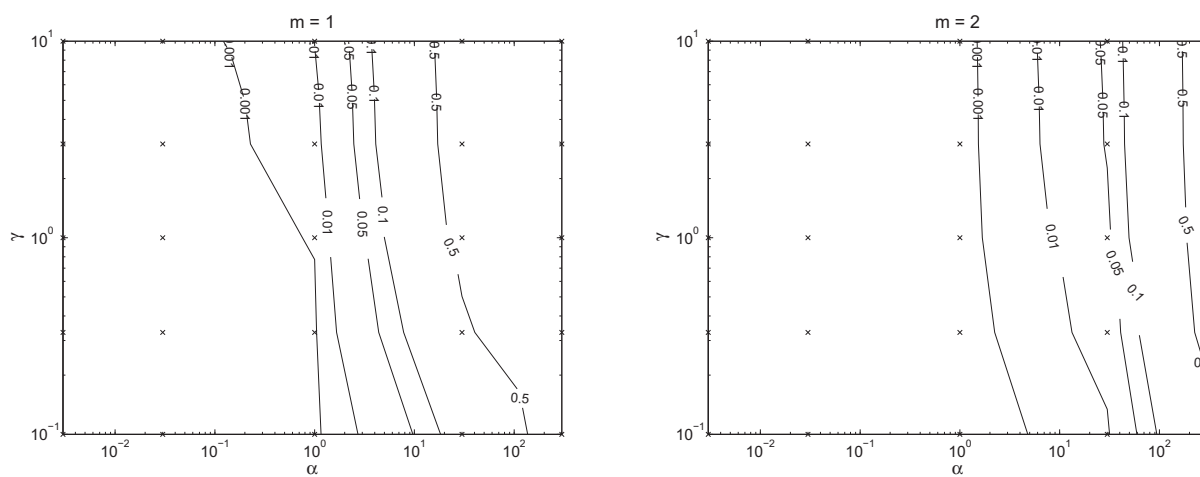

Figure D.1: *Steady-state error of the Galerkin method when $c_{in}^b = 1$.*

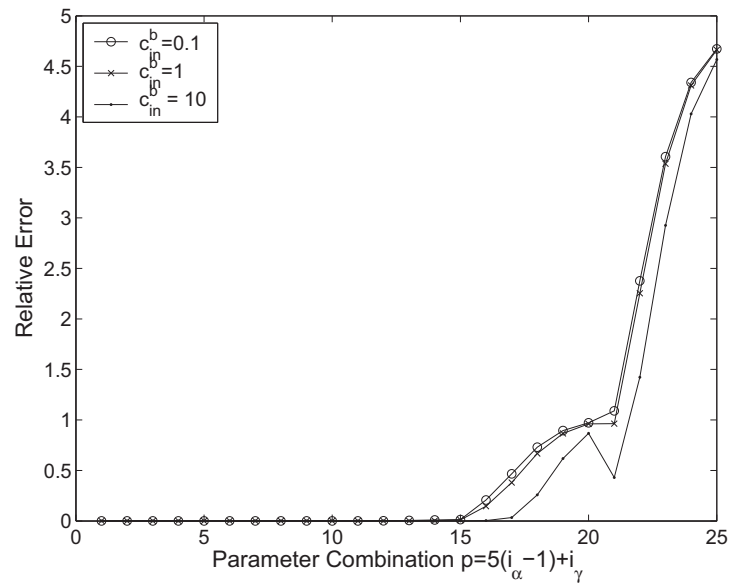

Figure D.2: *Influent concentration dependency for the orthogonal collocation method when $m = 1$.*

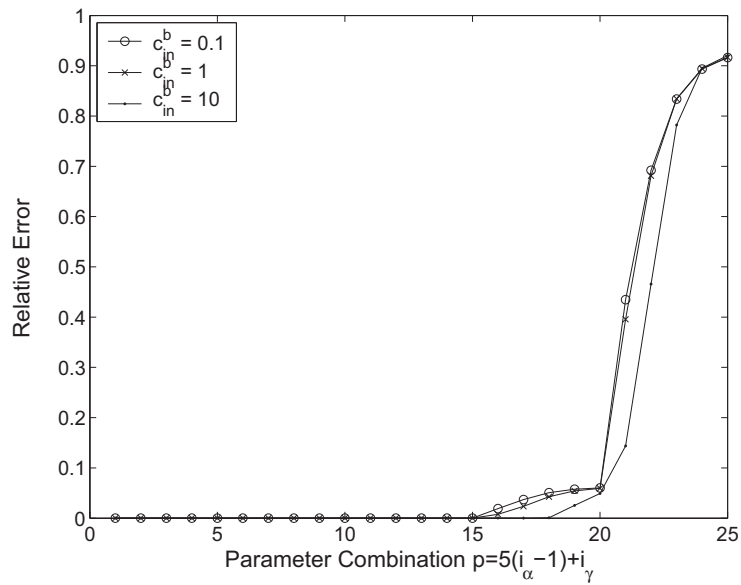

Figure D.3: *Influent concentration dependency for the Galerkin method when $m = 2$.*

Step Response

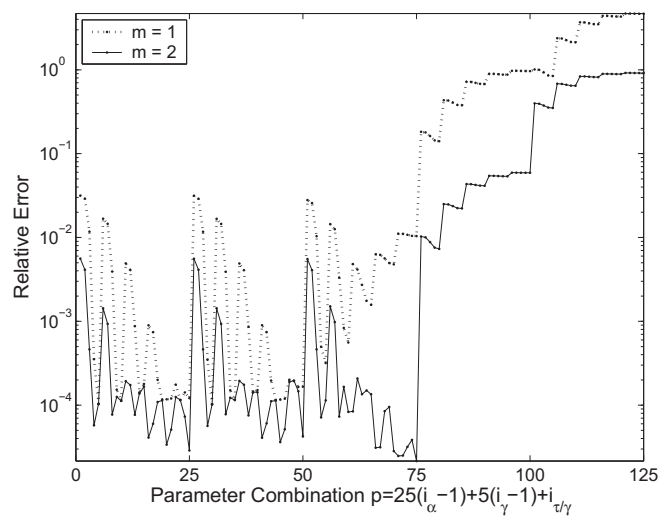

Figure D.4: *Relative error of the Galerkin method for a unit step response.*

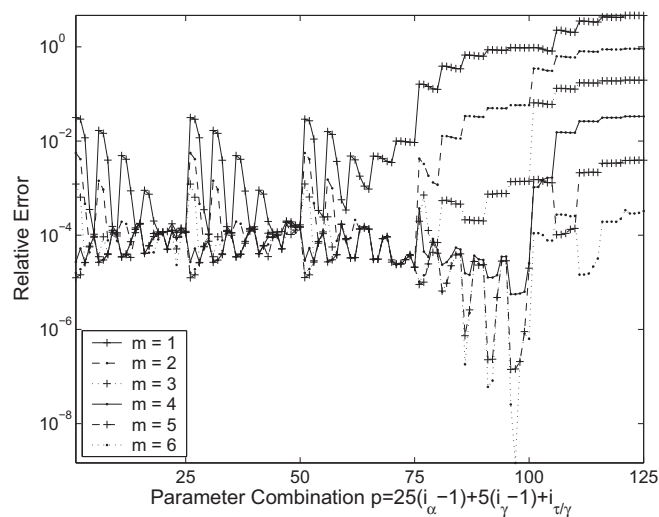

Figure D.5: *Relative error of the orthogonal collocation method for a unit step response.*

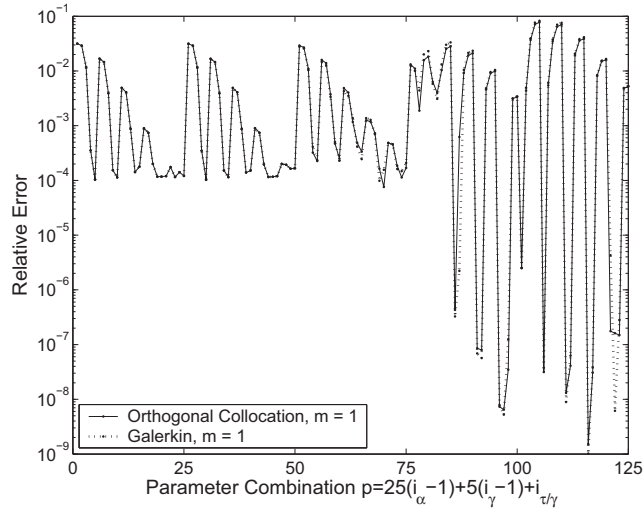

Figure D.6: *Relative error of the second order approximations for a unit step response divided by the stationary gain.*

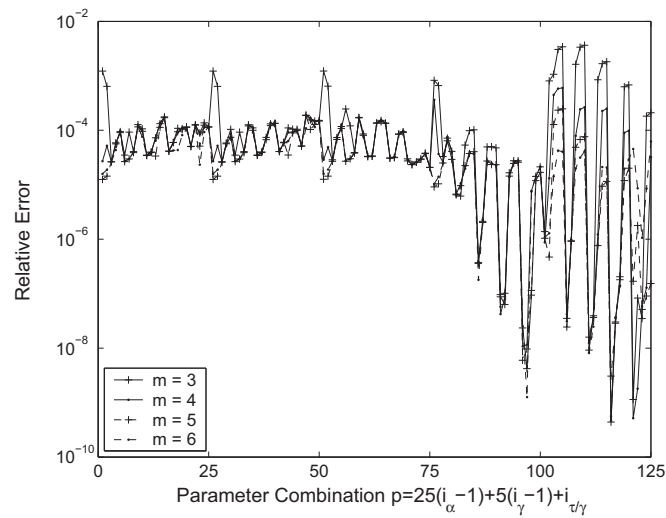

Figure D.7: *Relative error for a unit step response divided by the stationary gain.*

Impulse Response

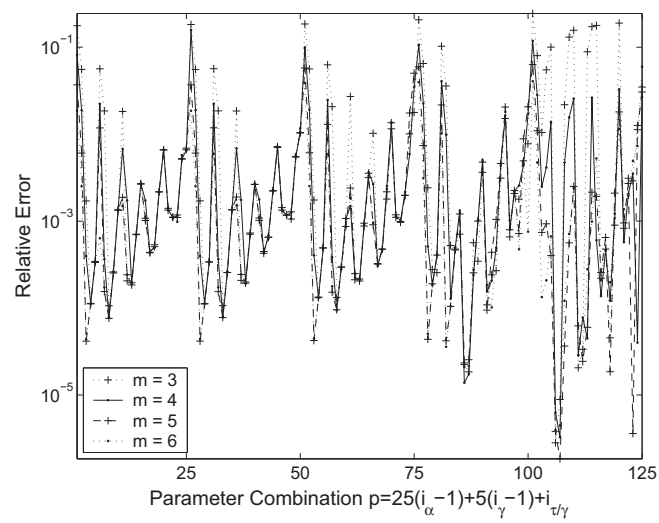

Figure D.8: *Relative error of the higher order orthogonal collocation approximations for an impulse response.*

Random Influent Concentration

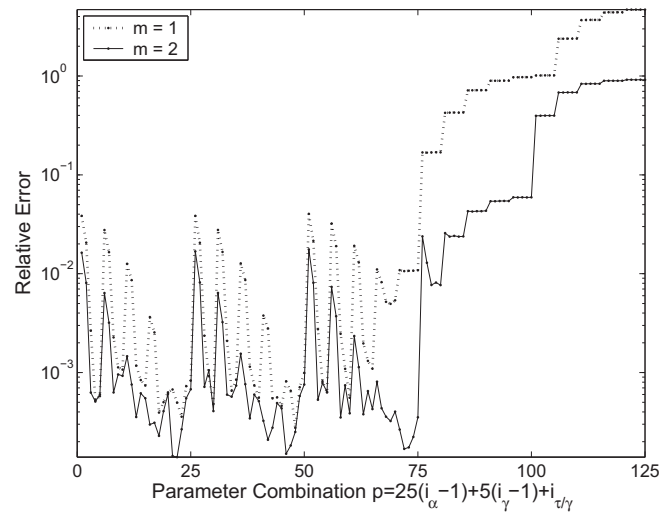

Figure D.9: *Relative error of the Galerkin method for a random input response.*

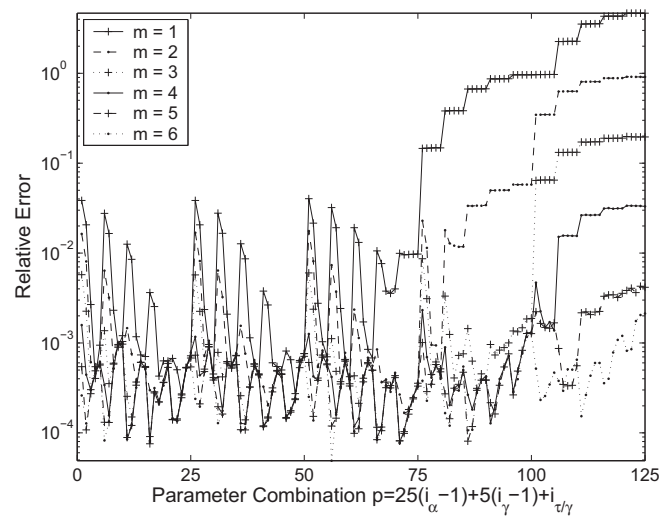

Figure D.10: *Relative error of the orthogonal collocation method for a random input response.*

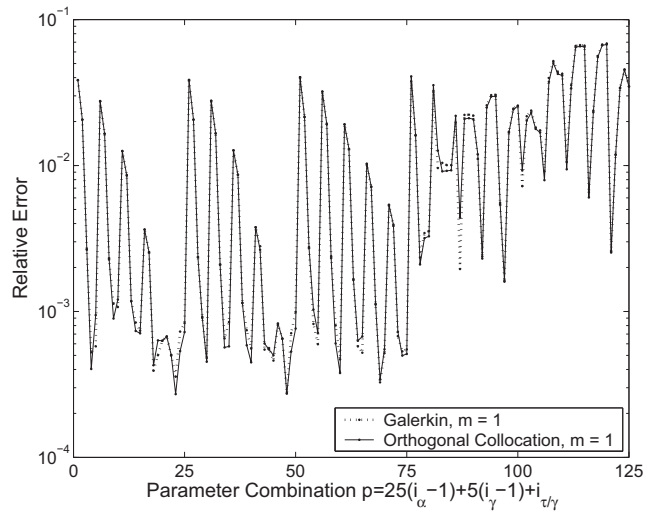

Figure D.11: *Relative error of the second order approximations for a random input response divided by the stationary solution.*

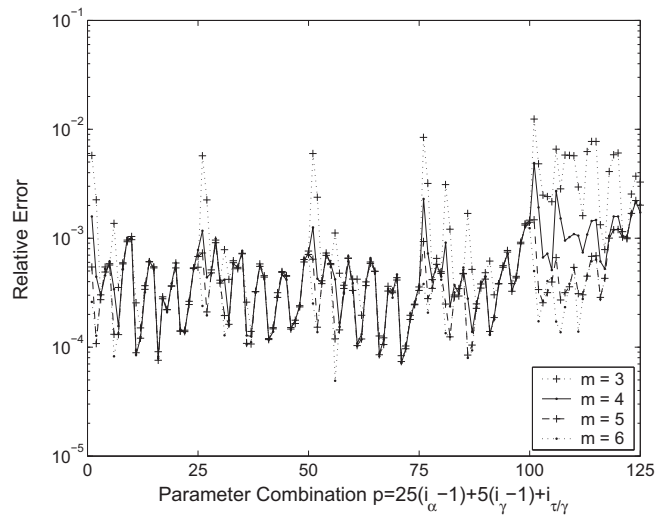

Figure D.12: *Relative error of the orthogonal collocation approximations for a random input response divided by the stationary solution.*