

# CHALMERS



## Concept development of field analysis equipment for mining and exploration application

*Master's thesis in the Master Degree Programme Product Development*

VASUPOL KUNAVUTI

Department of Product and Production Development  
*Division of Product Development*  
CHALMERS UNIVERSITY OF TECHNOLOGY  
Göteborg, Sweden, 2012

# Concept development of field analysis equipment for mining and exploration application

Master's thesis in the Master Degree Programme Product Development

VASUPOL KUNAVUTI

Department of Product and Production Development  
CHALMERS UNIVERSITY OF TECHNOLOGY  
Göteborg, Sweden, 2012

Concept development of field analysis equipment for mining and  
exploration application  
Master's thesis in the Master Degree Programme Product Development  
VASUPOL KUNAVUTI

© VASUPOL KUNAVUTI, 2012.

Department of Product and Production Development  
Chalmers University of Technology  
SE-412 96 Göteborg  
Sweden  
Telephone + 46 (0)31-772 1000

Göteborg, Sweden 2012



## **Preface**

This report is part of the thesis of the Master program Product development at Chalmers University of Technology in Gothenburg. The thesis has been formulated over six months, from September 2011 to April 2012. My advisor and examiner has been Professor Hans L. Johannesson.

During the formulation of this thesis, I received valuable assistance and information that has been critical in the successful completion of it. I would like to take this opportunity to thank all the people who have contributed in the different aspects of this thesis. Special thanks must be given to Mikael Arthursson and Annelie Blomdahl - supervisors and mentors at the company; Niklas Arthursson - product designer at the company and Efrain Calderon - development engineer at the company.

Also thanks to Hans L. Johannesson - advisor and examiner at Chalmers University of Technology, who guided me throughout the entire process.

Vasupol Kunavuti

Concept development of field analysis equipment for mining and exploration application  
Master's thesis in the Master Degree Programme Product Development

VASUPOL KUNAVUTI

Department of Product and Production Development  
Chalmers University of Technology

## **Abstract**

The problems with the exploration process within the mining industry are high investment and high risks because it takes a very long time and a lot of money to perform the analysis of the rock sample. With the developed equipment, the process will be shortened, thus benefitting the mining and exploration companies who are the potential customers.

The aim of this thesis is to create a feasible and production ready concept of equipment for performing field analysis of rock samples in mining and exploration application.

During the course of this thesis work, a product development process has been used. This process involves identifying requirements specifications, functional analysis, concept generation, concept evaluation and concept refinement.

The new product is a newly developed instrument that was improved from the first prototype. Mainly, the new feature of the machine is that it can scan multiple samples in a standard core box. The design emphasis of the instrument was on operability, usability, safety, transportability, environment and compact ability. The aim of the final design was to arrange the components in order to save space and weight, while maintaining the functionality and quality of the analysis. The three-dimensional CAD model prototype was created by using a computer-aided design program. The design was based on the final concept. The special focuses have been on the new feature of the instrument such as the loading and unloading of the core box. It is important that the final design is feasible for production, as the aim is to turn the concept into a fully functioning product. The result of the thesis provides the solutions that analyses multiple samples in a standard core box. The instrument can withstand the rough and tough environment, and the exploration process can be performed faster and more accurately.

Keywords: Mining, Exploration, rock analysis, core sample, core box

## Contents

<b>Preface</b> .....	i
<b>Abstract</b> .....	ii
<b>1. Introduction</b> .....	1
1.1 Background.....	1
1.3 Purpose.....	2
1.4 Objective .....	2
1.5 Scope .....	2
<b>2. Thesis Process</b> .....	3
2.1 Pre-Study phase .....	3
2.2 Research and conceptual analyses phase .....	3
2.3 Development phase .....	4
2.4 Refinement and deliverables phase.....	4
<b>3. Theoretical Framework</b> .....	5
3.1 Functional analysis .....	5
3.2 Relations diagram.....	5
3.3 Concept table .....	6
3.4 Concept Evaluation .....	6
3.5 Failure mode and effects analysis .....	7
3.6 Prototyping.....	8
<b>4. Concept development</b> .....	9
4.1 The existing prototype .....	9
4.2 Requirements specification.....	10
4.3 Functional analysis .....	12
4.4 Concept generation.....	12
4.6 Outcome concept.....	21
<b>5. Refinement</b> .....	24
5.1 Refinement of requirements specification .....	24
5.2 Refinement of the concept .....	25
<b>6. Result</b> .....	27
6.1 Final Design .....	27
6.2 Limitations.....	31
<b>7. Discussion</b> .....	32
7.1 Thesis process and Theoretical framework.....	32
7.2 Result.....	32

<b>8. Recommendation</b> .....	34
<b>9. Conclusion</b> .....	35
<b>10. References</b> .....	36
Appendix A: Planning report .....	37
Appendix B: Requirements specification .....	41
Appendix C: Functional analysis.....	47
Appendix D: Relations diagram .....	49
Appendix E: Concept table .....	50
Appendix F: Elimination matrix .....	53
Appendix G: Kesselring matrix .....	57
Appendix H: FMEA worksheet.....	60



# 1. Introduction

This chapter introduces the thesis which includes the proposal, objective and scope. In addition, the current situation of the market within the exploration and mining industry and the motivation of this thesis are also discussed.

## 1.1 Background

The mining and exploration industry is growing every year. In Sweden alone, a lot of new projects are moving towards production. In the upcoming year, the newly established mines are scheduled to start production and existing mines are expanding their production. For example, Dannemora iron ore mine north of Stockholm is planning to start production in 2012. The Northland resource in the north outside Pajala, on the border to Finland, is scheduled to expand their production to five million ton in 2013. Figure 1.1 (Value of exploration in Sweden 1982-2010) shows that in 2010 investments in exploration rose to 675 million SEK. The number of exploration permits rose by 40% in the first quarter of 2011 and 192 permits were granted up until September 2011, while another 50 are being processed at the Mine Inspectorate in Luleå. 323 Exploration permits have been granted extensions and a further 95 decisions are pending. (Tomas From, 2011)

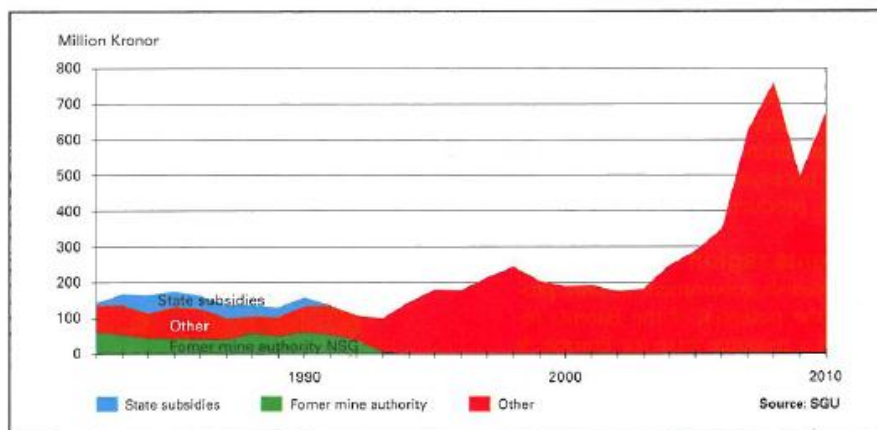


Figure 1.1: Value of exploration in Sweden 1982-2010 (million SEK, current price) (Tomas From, 2011)

In order to find the economically feasible mineral resources, the exploration drilling process is associated with high investment and major risk. Currently, mining and exploration companies use a portable XRF analyzer and geologist's judgment to select the core samples from several drill holes reaching hundreds of meters below the ground and send those samples to laboratories for accurate analysis. Figure 1.2 illustrates the exploration process. This process takes a lot of time and is very costly. In view of the information mentioned above, it is a great opportunity for the company to develop an instrument that can analyze rock core samples right at the mine and exploration site. With this new instrument, the process will be shortened since, the instrument can produce the scanned result on-site more accurate and repeatable than the delivered results by the portable XRF analyzer. The samples no longer need to be selected because the developed machine can analyze the entire sample from the drill hole.

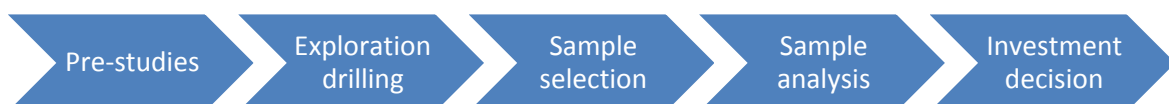


Figure1.2: The exploration process

The company decided to produce a single core scanner to reduce the complexity of the prototype. The next product will be an improvement on the design and function of the first prototype and will be produced in the future, based on the final concepts of this thesis.

### **1.3 Purpose**

The aim of this thesis is to generate feasible concepts of X-ray equipment based on the first prototype for performing field analysis of rock samples in mining and exploration applications. The developed equipment will be capable of analyzing multiple samples in a standard core box.

### **1.4 Objective**

The objective is to develop and redesign the current prototype equipment with emphasis on the following aspects:

- Operability, the developed equipment should be able to analyze more rock samples than the existing prototype.
- Usability, the machine should be easy to use according to ergonomics.
- Safety, it should be safe to operate.
- Transportation, the instrument should be easy to transport.
- Environment, the equipment should be able to operate in the rough and tough environment.
- Design, the instrument should be relatively small and light weight.

The intended outcomes of the thesis are the concepts' solutions for the following functions: loading and unloading the core box, movement of X-ray components and core box, transport solution, maintenance, environment, components layout, safety and outer design.

### **1.5 Scope**

Within its parameters, the thesis focuses on developing a concept of field analysis equipment. The thesis does not include programming of PLC or control software, operating software, user interface software and no physical product. This thesis does not go deep into the subsystem. However, it does make suggestions on specific components' layout and requirements. The developed equipment will be presented with CAD models. The thesis is planned to take 6 months to deliver the expected outcome.

Following areas will be developed during this thesis:

- Construction of the list of requirements specification
- Generate, evaluate and select the concepts of loading and unloading sample, movement of samples and components, maintenance and transportation
- Designing the layout of the instrument
- Designing the cover
- Create a CAD model and drawing

## 2. Thesis Process

The thesis follows the product development process, namely:

- Pre-study phase - organizing and structuring how the project will flow.
- Research and conceptual analyses phase - to study the current prototype in order to identify the problem and specify the requirement.
- Development phase - to generate, evaluate and select the concepts.
- Refinement and deliverables phase - finalizing the concept, writing the report and thesis presentation. (Masters Programme in Product Development, 2010)

### 2.1 Pre-Study phase

In the Pre-study phase, it is important to clearly state the purpose and scope of the thesis and to make agreements with the company at the beginning of the thesis. After starting the thesis, a meeting with the company was arranged. The main discussion was about the objective of the thesis and what is expected as a result. A misunderstanding of the goal and expected result can cause drawbacks to the thesis. The thesis description was formulated in order to briefly describe the topic. The description includes the background, purpose, objective, scope, stakeholders, method, time schedule and deliverables. This document was used to register the thesis.

The meeting between the examiner and the company was set up to discuss the confidentiality agreement of the thesis outcome. A planning report was written and used as a guideline for the thesis. The report contains the same topics as in the thesis description but with more information and detail such as the introduction of the company, the background of the first prototype, scope of the thesis as defined by the specifications of the company and a Gantt chart which shows the activities related to timeframes during the thesis. This chart is used as a constant reference. It defines the duration of each product development phase as well as the schedule of each stage gate and task. (See the planning report in Appendix A). The requirements of the new instrument were specified not only based on the requirements specification of the first prototype, but also based on some new requirements due to the new functions, new components and more specific target level.

### 2.2 Research and conceptual analyses phase

Product development is a methodical thinking process based on the knowledge and creative reasoning which was applied to this project. In order to gain the knowledge about the product to be developed, the research and conceptual analyses phase is the most important process. This phase is about market understanding, customer needs and specification requirements. (Masters Programme in Product Development, 2010)

The market research was accomplished by the company to explore the performance of the product in the market, the competitor companies that produce rock sample scanning equipment and potential customers from within the mining and exploration industry.

The first prototype was designed based on the idea from the Product development project. A good way to understand the concepts of the existing prototype is to study the product development project report including the market analysis, customer needs, requirements specification, the components and the idea behind the concept in order to develop the concept of the new instrument. The issue that was kept in mind during this process is that

some part of the report was not updated and needs to be improved. The next step was to study the sub systems and components of the existing prototype and create component structures to show the whole system of the machine. The manual of the sub components helps identify the requirements of the sub system. A process flow model was made to illustrate the input process and output of the existing prototype.

### **2.3 Development phase**

The Development phase begins with identifying the function and problem. The function mapping was done to show interference between the functions and to find the most effective and affected functions. The next step is to generate the concepts. The ideas were established and sketched to visualize the instrument. A brainstorming session with the company's representatives was set up to help develop the idea and to discuss alternative solutions. The concept table was used to present ideas and solutions of the whole system. The concepts were narrowed down by using evaluation methods such as Elimination matrices, the evaluations based on Go/No-Go screening and the Kesselring matrices. The Elimination matrices helped to eliminate unfeasible ideas. The evaluations based on Go/No-Go screening were used to screen the concepts. Finally the Kesselring matrices were used to select the promising ideas by applying rated criteria that were selected from the requirements after the discussion with the company's representatives.

The outcome concept is the result from using evaluation methods. It contains the solution of each function that suited the product. It is however possible that during the product development process the requirements might have changed or some solution might not be able to be applied to the equipment. The outcome concepts need to be refined in the next phase.

### **2.4 Refinement and deliverables phase**

In this phase, the outcome ideas were refined and finalized by assuring that the idea solutions are feasible and working well together. After establishing the final concept it is important to create a prototype of the product. The prototype is a visual representation of the concept. A CAD model was created by using the Autodesk inventor program. It is the best way to design the machine because if the concept is not feasible, or too complex to be accomplished in practice, the change of design can be made within the program. Finally, the report has been finished and presented.

### 3. Theoretical Framework

The method and tool that were used in the thesis including functional analysis, relations diagram, concept table, concept evaluation, failure mode and effects analysis and prototyping will be described in this chapter.

#### 3.1 Functional analysis

Functional analysis is the analysis of the system in terms of its purpose. It involves the description of the main function and sub-functions of the system. Two functional analysis methods were applied in the thesis, namely, Process flow model and Function means tree.

##### 3.1.1 Process flow model

The main purpose of a process flow model is to decompose the primary function into sub-functions. The flows regarding material, energy and information between the sub-functions are described. The method focuses on input operands, output operands and transforming function. Figure 3.1 illustrates the process flow model. This method was used in the thesis to define the flow of the analyzing process of the developed product in order to improve the desired function and design the new function. (Ullman, 1944)

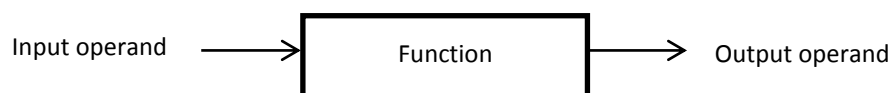


Figure 3.1: Process flow model

##### 3.1.2 Function-means tree

Function mean tree is an approach to capturing the functional requirements and decompose them in a hierarchical structure. It decomposes the sub-functions and sub-solutions, starting from the primary function. The purpose of this method is to define the interaction between the functional domain and physical domains. The tool consists of two types of nodes; functions - what needs to be done and means - how those can be done. This approach can also be a tool for idea generation. Figure 3.2 illustrates a function-means tree. Function-means tree was used in the thesis to provide an understanding of the relationship between functions and the components. (Ullman, 1944)

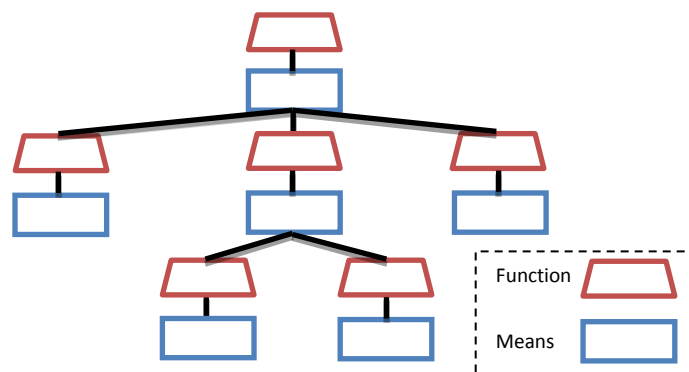


Figure 3.2: Function-means tree

#### 3.2 Relations diagram

The relations diagram also known as interrelationship diagram is used to identify cause and affect relationships between different issues. The relation diagram is created by identifying factors that are involved in the problem; draw an arrow from the greater influence (the cause)

to the lesser influence (the one influenced). The factor with the most outgoing arrows will be the driver or causal factor and the factor with the most incoming arrows will be an outcome or result. This tool was used in the thesis to organize the functions of the instrument. It identifies causal factors and help to decide which function to focus on. (Charantimath, 2009)

### 3.3 Concept table

The use of the concept table (see Table 3.1) was developed for this specific thesis. The concept table was used for two purposes, to collect the overall solutions in one table and to show the promising solutions that were evaluated from various methods. The alternative solutions were indicated by color code. The different colors mean that the solutions were excluded by different evaluation methods. The total amounts of possible solutions are massive and the functions of the developed product have unique characteristic, some can affect the complexity of the overall system, and some have individual properties, which can be influenced from other functions. To simplify the process, the sub-solutions have been evaluated and selected from each function before starting to combine the solution. The potential performance of a solution combination was synthesized to support the decision.

**Table 3.1: Concept table**

Function/ Sub-system \ Solution	1	2	3	...	m
F 1	S1.1	S1.2	S1.3	...	S1.m
F 2	S2.1	S2.2	S2.3	...	S2.m
F 3	S3.1	S3.2	S3.3	...	S3.m
:	:	:	:	:	:
F n	Sm.1	Sn.2	Sn.3	...	Sn.m

### 3.4 Concept Evaluation

Concept evaluation is the process of evaluating and selecting the potential concepts from the idea generation stage. The aim is to narrow down the amount of concepts and decide which concepts have the highest possibility for becoming an actual product. The concept evaluation methods were used in the thesis, including the Elimination matrix, the evaluation based on Go/No-Go screening and the Kesselring matrix.

#### 3.4.1 Elimination matrix

The Elimination matrix is a filter for the concepts. The evaluation is based on feasibility judgment. An idea will be excluded if it fails to fulfill one of the following criteria: solving the main problem, fulfilling the demands of the requirement list, realizable in principle, reasonably cost effective and safe. Each solution will be judged against the criteria. The result can be: Yes (+), No (-), Lack of information (?), or Check requirement list (!). And the decision for each solution can be: Pursue solution (+), Eliminate solution (-), Collect information (?), or Check requirement list for changes (!). In the thesis, this method was used to eliminate obviously disqualified solutions. It is a quick step before concept screening and concept scoring. Table 3.2 shows the Elimination matrix. (Pahl, Wallace, & Blessing, 2007)

Table 3.2 Elimination matrix

Solution	Selection Criteria					Remarks	Decision
	A	B	C	D	E		
S1							
S2							
:							
Sn							

### 3.4.2 Evaluation based on Go/No-Go screening

After that the concepts have passed the Elimination matrix, they will be evaluated against the criteria defined by the requirements specifications. The questions that generate from the requirements need to be answered with either Go, or No-Go. This method was modified to make it more suitable for the thesis. Instead of using the matrix, the evaluation was carried out in the meeting between the stakeholders. The discussion stemmed from which requirements should be selected to create the criteria preceding the screening process. (Ullman, 1944)

### 3.4.3 Kesselring matrix

A Kesselring matrix as shown in Table 3.3 is a concept scoring method. It is used to analyze potential concepts and finally selecting the final concept. The processes of the Kesselring approach are:

- Choose the criteria based on requirements.
- Determine the weight factors.
- Assign the grades for fulfillment of the selection criteria.
- Calculate the concept scores.

The final concept is selected from the best total score. The Kesselring matrix was applied in the thesis to evaluate and select the final solution of an individual function. The selection criteria and weight factors were carefully considered by the stakeholders. Each solution was assigned a numerical value corresponding to the level of fulfillment of the selection criteria. (Ulrich & Eppinger, 2008)

Table 3.3 Kesselring matrix

Evaluation criteria	Weight (W)	Concept 1		Concept 2		Concept m	
		Value (V <sub>1</sub> )	WV <sub>1</sub>	Value (V <sub>2</sub> )	WV <sub>2</sub>	Value (V <sub>m</sub> )	WV <sub>m</sub>
A	W <sub>1</sub>	V <sub>1A</sub>	W <sub>1</sub> V <sub>1A</sub>	V <sub>2A</sub>	W <sub>1</sub> V <sub>2A</sub>	V <sub>mA</sub>	W <sub>1</sub> V <sub>mA</sub>
B	W <sub>2</sub>	V <sub>1B</sub>	W <sub>2</sub> V <sub>1B</sub>	V <sub>2B</sub>	W <sub>2</sub> V <sub>2B</sub>	V <sub>mB</sub>	W <sub>2</sub> V <sub>mB</sub>
C	W <sub>3</sub>	V <sub>1C</sub>	W <sub>3</sub> V <sub>1C</sub>	V <sub>2C</sub>	W <sub>3</sub> V <sub>2C</sub>	V <sub>mC</sub>	W <sub>3</sub> V <sub>mC</sub>
:	:	:	:	:	:	:	:
n	W <sub>n</sub>	V <sub>1n</sub>	W <sub>n</sub> V <sub>1n</sub>	V <sub>2n</sub>	W <sub>n</sub> V <sub>2n</sub>	V <sub>mn</sub>	W <sub>n</sub> V <sub>mn</sub>
	∑W		∑ WV <sub>1</sub>		∑ WV <sub>2</sub>		∑ WV <sub>m</sub>

### 3.5 Failure mode and effects analysis

The Failure mode and effects analysis (FMEA) is a technique for identifying failure potential and its consequences and the methods to reduce the chance of failure occurring. FMEA is used

as a design evaluation tool and as a design aide. A failure can be a mechanical failure, based on any chance that the component, assembly, or system fails to perform its intended function. Table 3.4 illustrates the FMEA worksheet. It contains four indicators - Potential failure, Potential effects of failure, Potential cause and Current controls. Also there are three ratings - Severity, Occurrence and Detection. (Otto & Wood, 2001)

Severity relates to the seriousness of a potential effect of failure on a scale from 1 – 10. 1 implies no effect and 10, implies a very high and hazardous effect. The failure may result from the product becoming inoperative or unsafe and could result in possible injury. Occurrence is the probability of failure based on potential cause(s), over the lifespan of the product. This is indicated on a scale of 1 - 10, where 1 implies failure unlikely and 10 implies failure is almost inevitable. Detection relates to the possibility that current controls will detect the potential failure before sending the product to the customer. Finally, a Risk Priority Number (RPN) is calculated from these values. (Otto & Wood, 2001)

**Table 3.4: FMEA Worksheet**

Function	Potential Failure mode	Potential Effects of Failure	Severity (S)	Potential Cause(s)	Occurrence (O)	Current controls	Detection (D)	Risk priority number (RPN)

**3.6 Prototyping**

Prototyping is the process of developing an approximation of the product. It provides an efficient and effective method to modify and improve the product through the testing and iterative revision. In the thesis, three-dimensional computer modeling (3D CAD) was chosen to produce the 3D computer aided design models of the actual product. Within the thesis, the 3D CAD model was used for four purposes. Firstly learning, the prototype is used as a learning tool. The designed part can be adjusted as many times as it is required until the result is satisfactory. The estimation can be made to test the outcome and generate discussion for further development. Secondly communication, the prototype shows the visual of the product. It not only enhances the communication with the customer and investor, but also the manufacturing process as well. The three-dimensional CAD model is much easier to understand than a sketch or drawing. Thirdly integration, the 3D CAD model can demonstrate the assembly of the product to ensure that the components and sub-systems fit together as designed. Finally as milestones, if the prototype fulfills the requirements, this can be used as a yardstick at various stages of production to ensure that each stage of the development of the product goes well and will perform as expected. (Ulrich & Eppinger, 2008)



## 4. Concept development

This chapter describes the background of the first prototype, identifies the problem and lists the functions that needed to be improved. The product development process is also outlined in this chapter starting with establishing the required specifications, functional analysis, concept generation of the different functions, evaluation and outcome concept.

### 4.1 The existing prototype

The instrument's project stemmed from the product development project. The purpose of the project was "To help the company realize their vision of rationalizing the prospecting process and to design a concept for a basis for further development." (Braggsjö, Halonen, Johansson, Krpo, Sernevi, & Smajic, 2010). The project includes market analysis that was conducted around four main areas: politics, economics and social issues, technology in prospecting, possible market segments and competitors and their solutions. The final concept of the project was called Mobile Automated-Drill Core Analytical Technique (MADCAT) which combined the concepts of different sub-functions, namely, chassis, user interface, analyzing, core-handling, environmental protection and positioning of components. (Braggsjö, Halonen, Johansson, Krpo, Sernevi, & Smajic, 2010)

The company decided to produce a single core scanner instead of a core box scanner to reduce complexity of the system. The final concept of the development project differs from the prototype in the following aspects; the number of input samples, sub-system and components because at that time the development team hadn't gained the knowledge about the components and sub systems yet and there existed a lot of unclear information and uncertainty. Furthermore, the technology was nonexistent or not well known yet. The choices the development team made for the final concept was the best solution for the situation at that time.

The existing prototype is a single core scanner. It can only analyze rock samples that are smaller than 0.5 meters at one time. The instrument uses an X-ray fluorescence (XRF) technique for the analyzing process. XRF is a non-destructive analytical technique used to analyze rocks, minerals, sediments and fluids. According to Beckhoff, Kanngießner, Langhoff, Wedell and Wolff, the XRF principle can be explained as follows. When the inner electron is excited by photons in the X-ray, the atoms becomes unstable and an outer electron moves from a higher energy level to fill the gap of the missing inner electron. During the process, energy is emitted due to the energy difference between the two shells. The released spectrum reveals a number of characteristic peaks that can be used to detect the identification of the elements that exist in the sample.

During the study phase, the component structure was created to make an understanding of the entire components. The main sub- systems of the prototype are power system, motor system, X-ray system, cooling system, controlling system or PLC, chassis and user interface. The aim of studying the sub systems and its components is to find an answer to these questions. "What are the functions of the components?" and "Why does the instrument need it?" These questions are addressed by studying the manual of each component and then making a components list by categorizing the components into sub systems and listing the important requirements and specifications of each sub system. In addition, a list of pros and cons of each component has been made. Some components might not be suitable for the next

product, such as a high voltage generator with improved technologies, a smaller model with higher power is available and also a laser sensor that can be useful for the developed product was found since producing the first prototype. The cooling system of the prototype is huge and it would probably be better to change it in the developed product of which equipment size is a crucial requirement. The purpose of the instrument is to analyze rock sample which in the prototype case is only a single core at a time, but the next machine is aiming to analyze multiple samples in a standard core box. Figure 4.1 displays the single core scanner.



Figure 4.1: The first prototype

#### 4.2 Requirements specification

The requirements are based on the requirements of the existing prototype and the requirements of its sub systems and components. The problem is that the requirements of the existing prototype has not been updated and are unclear because of its lack of detail, hard to measure and the limit values are not appropriate. The requirements list of the developed instrument was formulated with additional information and the knowledge gained from the prototype. Furthermore the requirements of the new function of the instrument were added into the requirement list.

The big difference between the existing prototype and the new machine is that instead of a single core scanner, the new one can scan multiple samples in a standard core box (See Figure 4.2), which means that the developed equipment is a lot more complex than the existing prototype. It has new functions, such as loading and unloading the core box and the movement of the X-ray components. Another issue is the company wants the new instrument to be compact by putting every component inside the machine and it must be easy to transport. Hence, the new design is suitable to be used at the drill site.



Figure 4.2: The standard core box

For the new product, the new requirements were added and some of the target levels were changed in order to support the new functions and components of the instrument. After discussions with the company, the first draft of the required specifications was created. The requirements were not complete because some of the values were unknown and some requirements needed to be discussed further in the next phase of the development process. For example, the performance of the

instrument such as the analytical speed and analysis accuracy depend on the type of material that the user is looking for. The different settings of the searched material can change the speed of the analytical process. Also some requirements are vague and hard to interpret. Another issue that is significant for the instrument is safety with regards to radiation. For this, both Swedish and EU legislations need to be studied so that it can be implemented effectively.

The list of requirements consists of the type of requirement, either demand or wish, the requirement statement, target level, validation and evaluation/verification. Table 4.1 shows the examples requirements that have high priorities for the design criteria. The full required specifications can be found in appendix B.

**Table 4.1: The requirements**

Requirement	Description
Samples should not move during the analyze process	If the samples move during the analyzing process, it will affect the quality of the result. The user can check the position of the sample from the photo.
Sound level	The instrument should not have a sound level more than 90dB as this is limited by work place regulation. The sound level can be measured by using a dB meter.
Operations manual	The machine should have a user's manual to help the user understand how to set up and execute the processes.
Calibration system	To help calibrate the instrument in order to get the best accurate result. The system should detect the position of the sample.
Internal storage	The instrument should have an internal memory used for recoding the result, position and photo of the sample.
Easy data transfer with authorization lock	A security system that allows only an authorized person to get access to the data.
Ergonomic	The working process should consistent with the regulation AFS 1998:1 Belastningsergonomi
Machine reliability	The reliability rate should be within 96% of operating time to fulfill the customer's expectation.
The analyzing process should not affect the sample	The sample before and after the analysis should be in the same state.
Machine protection	During transportation it is important that the machine is suitably protected as the sensitive components could get damaged.
Portability	It is essential that the machine can be transported to the work site.
Rock sample (core box)	The machine should be able to input a standard core box and scan the rock samples in both cylinder and half cylinder form, either small or large iron core.
Environment	Protection from the environment in terms of inside temperature, humidity and water that leak from the core box. Figure 4.3 shows the environment of drill site.

Safety	The system should shut down the machine automatically when the hatch is open or the emergency stop button is activated to prevent exposure to radiation. The instrument should have warning indicators such as a warning lamp integrated and visible from 360 degrees around the instrument.
Radiation standard	This must be in accordance with the Swedish Radiation Safety Authority's rules regarding usage of industrial equipment that contains closed radiation sources and X-ray tubes. (Swedish Radiation Safety Authority, SSMFS 2008:4)



Figure 4.3: The illustration of drill site. On the left, the drilling machine. To the right, the stack of core boxes.

### 4.3 Functional analysis

The functional analysis was conducted at the beginning of the development process in order to identify the primary function and the sub-functions of the instrument. The analysis was based on the study of the existing machine's function. By improving the desired functions and adding the new functions that correspond to the requirements, the functions of the developed machine were established. Two functional analysis methods were used in the thesis; the process flow model and the function-mean tree. Both methods are useful for decomposing the main function into sub-functions. The process flow model gives a good understanding of the flow of operands, including material, energy, signal and information, while the function-mean tree explains the relationship between the functional domain and physical domain. The primary function of the new instrument is to analyze rock samples. This can be broken down into sub-functions: load the core box, detect the core box, move the core box, move the analysis equipment, analyze the samples and unload the core box. The process flow model and function-mean tree can be found in Appendix C.

### 4.4 Concept generation

From the study of the first prototype, the problems and the functions needed to be improved were identified. The main functions are load core box, detect core box, move core box, move X-ray components, analyze sample and unload core box. The next step is to select the design aspects.

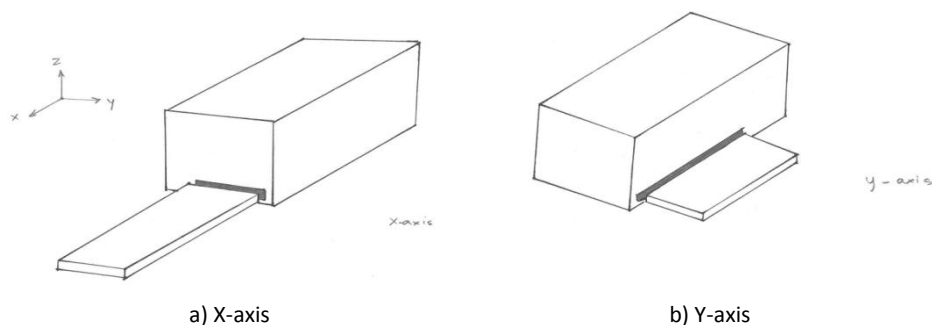
Regarding to the main functions and the requirements of the instrument, the aspects, considered to be designed, are loading and unloading the core box, movement of the X-ray and core box, transport solution, maintenance, environment, components layout, safety and

outer design. Mapping the aspects by listing them according to functions and then using the relation diagram to illustrate how these aspects affect each other was found to be most effective. The aspect that has an arrow coming out, has the greater influence (the cause), on the other hand the aspect that has the arrow coming in is influenced. The relations diagram (See Appendix D) shows that the most influencing design point is the loading and unloading of the core box and the aspect that is affected the most by other functions is components layout. From this point the concept generation was started by following the order from the diagram, beginning with the aspect that is not affected by the others, then finding solutions for the problems that are more complex and caused by the design points that have already been solved.

#### 4.4.1 Loading and unloading the core box

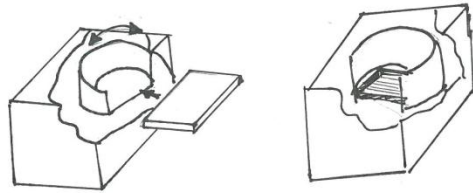
According to the relations diagram loading and unloading samples affect other aspects the most. It influences the function of the movement of the X-ray tube and core box, control of the inside temperature and component layout. The idea generation process was started from this aspect and the result of this aspect can change the direction and outcome of the solution of the other aspects.

The loading and unloading the core box is a function of how to handle the core box, how to import the core box inside the instrument and how to export it after finished scanning. The function is divided into two sub functions which are direction and method. The solution for the direction of loading and unloading samples is limited by the location of the working site. Since the purpose of the product is for field use, the only directions that are possible for the solution are in X-axis or Y-axis (See figure 4.4). In contrast the methods of loading and unloading are more flexible.

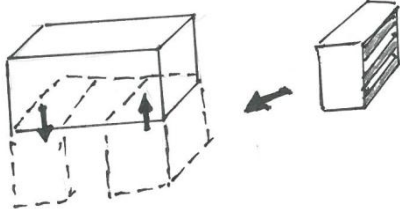


**Figure 4.4 a)-b): the direction of loading and unloading sample**

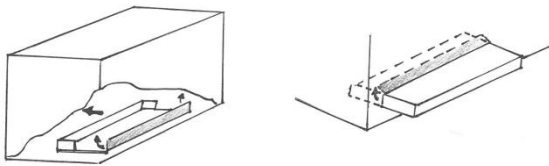
In the beginning of the idea generation process, the outcome of the method of feeding the core box were vague and without detail. There were only some ideas of how to open and close the hatch. The issues about which side of the core box should be loaded and if the core box should be loaded or unloaded from the same door were still under question. After the discussions with the company's entrepreneurs, some preliminary ideas were put forward. A new loading and unloading solution called "video player" was proposed. It's based on the same principle as a video player. The examples of the methods of feeding the core box are shown in figure 4.5 a) – f).



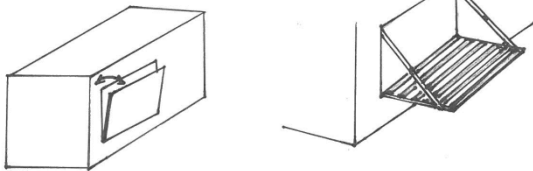
a) Rotation  
Loading and unloading the sample by rotating the feeding disk.



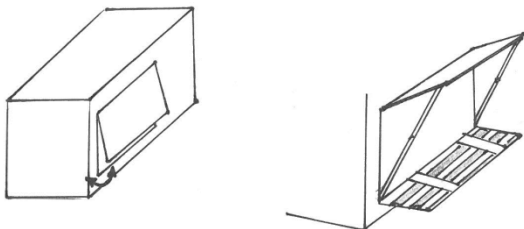
b) Lift up  
The sample cabinet fits under the machine. The core box is then lifted up to the start position. Unloading happens on the other side of the machine



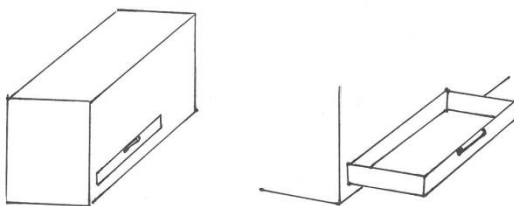
c) Video player  
Insert the core box horizontally inside the machine



d) The oven  
The feeding hatch opens like an oven door



e) Sledge  
As the hatch swings up, the sledge slides out



f) Drawer  
The hatch slides out like a drawer

Figure 4.5 a) - f): Loading and unloading idea solutions.

#### 4.4.2 Movement of the X-ray components and core box

The movement of the X-ray components and core box are complicated aspect because the mechanisms of these functions can affect the size of the instrument. The purpose of the thesis states clearly that the developed instrument should be compact and as small as possible. According to the requirements, the size of the machine is limited by the width of a standard door, 80 cm. The height is 75 cm, being the same as the existing prototype. The length of the machine depends on the core box size and the mechanism of this function.

The movement of the X-ray components and core box should be consistent and work well together. The scanning area should cover the entire sample in the core box. Three possible solutions were realized. In later stages, the two of the solutions were eliminated because it was realized that the core box cannot move along the X-axis. Hence, there was only one option for this function.

An animation of the movement of the X-ray equipment and core box was made by using Autodesk inventor for visualization and presented to a big Swedish mining company and potential customers.

#### 4.4.3 Transport solution

For the transport solution, the first discussion with stakeholders focused on how to deliver the instrument to the customer safely. Since the machine consists of sensitive components, it is important to make sure that the instrument before and after transport is in the same state, and be able to set up and run as fast as possible. In later discussions, it came out that the possible solution for delivering the instrument from point to point, for example between drilling site or from the company's office to working location is to use sub-contractors because the instrument is of very high value. Sub-contractors will be responsible for any damages to the machine during transportation. The next topic within transportation is how to protect the instrument from damage during transportation and how to place the instrument inside the vehicle.

The transport solution focuses mainly on outer protection and securing the instrument. The special care must be taken to protect the window and the panel and securing the instrument in the vehicle. The solution was inspired by the protection process from different ideas such as the fire truck that uses roll up doors to protect the inside equipment and the container solution that has special attachments whereby the instrument will be secured. Another possible solution would be to make forklift pockets for the forklift to be able to move the instrument.

#### 4.4.4 Maintenance

The maintenance list was created by listing the maintenance requirements of each component in order to design the layout for further processes. The component manuals are the significant source of information. The dimensions and technical data, such as operating temperature can be found in these manuals. The maintenance list consists of the list of components in each different sub system, the model of component, weight, operating temperature, storage temperature, humidity, list of maintenance activities and installation notes. The list does not only consider the components of the first prototype but also includes the new possible components that might be involved in the new instrument.

The maintenance list gives the information about how often the user needs to access the components. Some sensitive components need special treatment and more dedicated attention than others.

Some examples of maintenance would be:

- The X-ray tube. In general the glass surface should kept clean and dry at all times, the cooling circuit inside the tube needs to be inspected and cleaned and the X-ray tube itself has a specific life span and needs to be changed.

- The cooling system requires the checking of the water level and heat exchanger. The water needs to be refilled and the filter of the pump are checked and cleaned every 3 months.

The maintenance information will affect the components' layout because the components that require frequent maintenance and regular checking should be placed in the position that's easy to access by the user. Regarding the non-disclosure agreement, the information within the maintenance list cannot be disclosed because it contains a list of the components, model and supplier and other sensitive information.

#### 4.4.5 Environment

The main goal of this thesis is to develop the instrument for field use. To achieve that goal the instrument should withstand the harsh environment of the mining and exploration field. The factors that can affect the performance of the instrument or jeopardize the operation are temperature and humidity inside the machine, because the components of each sub-system can withstand a different range of temperature and humidity. For example, the operating temperature of the high voltage power supply is between -40 to 85 degree Celsius while the X-ray tube can operate at 5 to 40 degree Celsius. The temperature inside the instrument should be adjusted to within a suitable range so that all the systems can operate properly.

The solutions of this problem came from different ideas. Some ideas were based on the solutions from other machines such as a heater, fan and dehumidifier to control temperature and humidity or a single component to control both temperature and humidity would be ideal. Other ideas were to use air curtains or controlled air flow to prevent the outside air from contaminating air inside the instrument.

#### 4.4.6 Components layout

The idea behind the layout was to fit all components inside the instrument. In the first prototype, the sub systems were located outside the machine including electronic storage cabinet, cooling system and High voltage generator. Only the analysis components were placed inside the machine. In the next product, the functions are more complicated than the prototype which means it has more components. The challenge of the design was to limit the size of the instrument. Other factor that might affect the layout was the sensitivity of the sub systems. For instance, a high voltage generator will create a magnetic field that might affect other electrical components during the operation.

Initially two component layouts were proposed to the stakeholders. Autodesk inventor was used to create a visualization of the layout. At this stage, the problems of both layouts were not yet realized. However, throughout the development process the layout has been redesigned and improved many times. The details will be discussed in the next chapter, Refinement.

Another issue regarding components' layout was the design of the X-ray equipment. Measurements of the X-ray parts were conducted in order to get the dimensions of the components.

#### 4.4.7 Safety

The safety of the machine is really important. This aspect was considered to be the first priority for the design factor. The safety function of the instrument was based on the Swedish



Radiation Safety Authority's rules regarding usage of industrial equipment that contains closed radiation sources and X-ray tubes. The safety functions included a warning light, alarm system and security system.

For the warning light, the user should be able to see the light from a 360 degree view around the machine. The possible solutions were to either put one light on top of the machine or install four lights on each corner of the machine. The alarm system involves an emergency stop, status light or alarm sound. Lastly, the security feature was to prevent the user from get exposed to the X-rays. In other words, the door and hatch of the components that connect to the analysis cage should be securely locked as to avoid X-rays getting out. The solutions for this include a key lock, magnetic lock, door sensor and to use a key to start the instrument.

#### 4.4.8 Outer design

The design of the front door that is used for maintenance of the components inside the analysis chamber such as the X-ray tube was inspired by the doors of a bus, garage door etc. Examples of the possible solutions are shown in Figure 4.6.

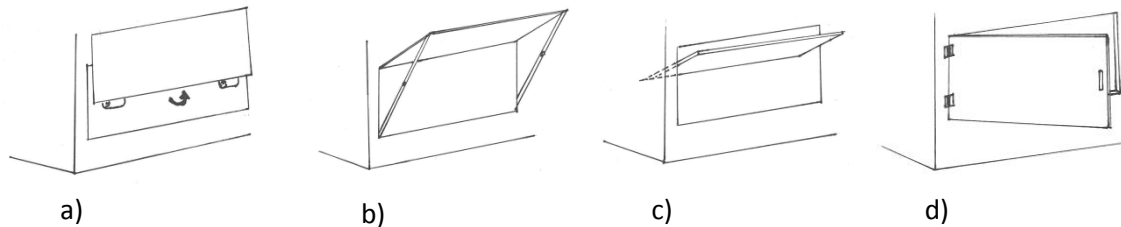


Figure 4.6 a) - d): Possible front door solutions

The cover of the instrument was designed by Niklas Arthursson, Product designer. The design was based on the idea solutions stemming from the idea generation process. The requirements for the outer design are the instrument should be strong, durable and compact, but still be visible as high-tech equipment. After discussions with the stakeholders in this project, the final design of the outer parts was selected. Figure 4.7 shows the final design of the instrument.



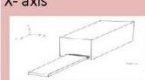


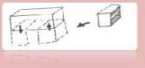




Figure 4.7: Final design of the instrument

#### 4.5 Concept evaluation





During the idea generation process, the possibility of each process, such as the loading and unloading the core box, movement of the X-ray components, etc. was discussed with Niklas and the company's entrepreneurs and feedbacks were given to improve the concepts. Some concepts were unfeasible or do not correspond with the requirements. In the meeting, the aspect that should be focused on and problems that came up during the development process such as the structure of the chassis, inspection table and warning light were discussed.

In the thesis, the concept table presenting in Table 3.1, was created for collecting alternative solutions of different functions in one place in order to get the complete idea of the overall process. Due to the sensitivity of some of the solutions and functions the alternative solutions were evaluated one by one. An example of the concept table is shown in Table 4.2, and the complete version can be seen in Appendix E. The simple way to evaluate these solutions is to select the best solution for each aspect instead of evaluating a random combination of solutions because some aspect can affect the complexity of the entire system. The result from the evaluation is shown in different colors. The colors indicate type of method that used to exclude the alternative solutions.

**Table 4.2: Extract from the concept table**

Function/concept	1	2	3	4	5	6
1. Loading and unloading the core box						
1.1 Direction	X-axis 	Y-axis 				
1.2 Method	Rotation 	Lift up 	Video player 	The oven 	Sledge 	Drawer 

	Excluded by Elimination matrix
	Excluded by Kesselring matrix
	Excluded by Evaluation based on Go/No-Go
	Selected concepts

The evaluation of the solutions was conducted in three stages. Firstly, the Elimination matrices were used to exclude clearly disqualified solutions. Secondly, concept screening was performed by using the evaluations based on the Go/No-Go approach. Finally, concept scoring was conducted by using the Kesselring matrices as an evaluation and final selection tool.

##### 4.5.1 Elimination matrix

The Elimination matrix is a preliminary screening method used to exclude the concept solutions that are not possible to produce. The decision is based on the fulfillment of the criteria. According to Pahl, Wallace and Blessing, the selection criteria consist of:

Criterion A: The solution proposals are compatible with the overall task and with one another.

Criterion B: The solution proposals fulfill the demands of the requirements list.

Criterion C: The solution proposals are realizable in respect of performance and layout.

Criterion D: The solution proposals are expected to be within permissible cost.

Criterion E: Compatible with safety standards and introduce favorable ergonomic conditions.

The solution will be eliminated when it fails to fulfill one of the criteria. For example as mentioned before, the possible solutions of the feeding direction were narrowed down to one solution which is Y-axis because the other solution, X-axis fails to fulfill criteria C (unrealizable in principle).

In Table 4.3, the Elimination matrix shows the various methods of loading and unloading the core box. However, some solutions were eliminated because they do not fulfill all the criteria. For some solutions, more information is needed before a decision can be made. The outcomes of the elimination matrices were carried on to the Kesselring matrix. The full version of the Elimination matrix can be found in Appendix F.

**Table 4.3: Elimination matrix of methods of loading and unloading core box**

Solution	Selection Criteria					Remarks	Decision
	A	B	C	D	E		
1. Rotation	+	-				Unfeasible/Bigger than requirement	-
2. Lift up	+	+	-			Incompatible with layout	-
3. Video player	+	+	+	+	+		+
4. The oven	+	+	+	+	+		+
5. Sledge	+	+	+	?			?
6. Drawer	+	+	+	+	+		+

#### 4.5.2 Evaluation based on Go/No-Go screening

The other method that was used to exclude ideas that were not suitable for the machine was to evaluate them by the fulfillment of the selection criteria defined by the stakeholders. Although some ideas fulfilled the criteria of the Elimination matrices, they were not preferred by the company or were simply not feasible at the time. From the discussions between the stakeholders, the ideal solutions were sought. The advantage of this method is that it generates discussion between stakeholders, from which new criteria were recognized and discussed. This method is also very flexible and easy to apply. The functions that were evaluated using this method were transport solution, system layout and safety. For example, for the system layout, two possible solutions were proposed with the difference in the position of the cabinet, cooling system and high voltage generator. Both solutions have their own strengths and weaknesses. After considering the criteria of maintenance, the stakeholders made their decision.

The other examples are safety functions. One of the requirements states that the instrument should have warning lights that can be seen 360 degrees around the machine. There were two possible solutions either place one warning light on top of the machine or put a light on each corner of the machine. The advantage of a single top positioned light is the number of light bulbs needed and the easy and straight forward design. On the other hand, a possible problem is the possibility that the machine might be installed on a table or some other high-up position, so that the user is unable to see the light.

With the corner positioned solution, the advantage is that the lights are integrated into the frame and are easy to see by the user. The drawbacks are that it is more expensive and the design is more complex. After the discussions, the stakeholders opted for the corner

positioned lights because it passed the safety criterion which is more serious than the cost criteria. The alarm warning function was excluded during this process. Even though the purpose of this function is good, it was not essential for the first development of the instrument.

#### 4.5.3 Kesselring matrix

The Kesselring matrices, introduced in chapter 3.4.3, were applied after the Go/No-Go screening. The result from this process will be integrated as the outcome concept. The process of selection begins with the meeting with the company's representatives to deal with the specifications requirements. The problem is that all the requirements need to be prioritized. By rating each requirement this can help solve the selection process. A rating was given to each requirement depending on the importance of the requirement.

Hence:

5 = very important

4 = between medium and very important

3 = medium important

2 = between medium and not important

1 = not important

Note that a rating of 1 doesn't mean that the requirement will not add value to the machine.

The solutions that were evaluated by the Kesselring matrices are loading and unloading the core box, environment control and the front hatch. Firstly the method of feeding the core box into the machine, the possible solutions are: video player, the oven, sledge and drawer. When evaluating each possible mechanism, a rating system was applied to each of the following criteria: ergonomics/safety, reliability, performance (speed), size, maintenance, environment (temperature) and cost, the result shows that the video player option has the maximum total weighted value. This means that the best outcome concept for the feeding function is the video player solution. The example of the Kesselring matrix: Loading and unloading the core box is shown in Table 4.4. Secondly the environment control function, the selected criteria focus on controlling the inside temperature, humidity control and reliability of the instrument. Finally the front hatch, the main criteria for each function depends on the selected requirements. Some requirements are significant in all functions because it can affect the status of the entire system such as reliability and maintenance.

**Table 4.4: Kesselring matrix: Loading and unloading the core box**

Criteria	Weight (W)	Video player		The oven		Sledge		Drawer	
		Value (V1)	Weighted Value (W*V1)	Value (V2)	Weighted Value (W*V2)	Value (V3)	Weighted Value (W*V3)	Value (V4)	Weighted Value (W*V4)
Performance (Speed)	0.11	5	0.53	4	0.42	2	0.21	4	0.42
Weight	0.08	5	0.39	3	0.24	3	0.24	5	0.39
Size	0.11	4	0.42	3	0.32	3	0.32	4	0.42
Ergonomic/Safety	0.13	4	0.53	2	0.26	1	0.13	3	0.39
Reliability	0.13	5	0.66	3	0.39	2	0.26	4	0.53
aesthetic design	0.08	4	0.32	3	0.24	3	0.24	4	0.32
Maintenance	0.11	3	0.32	4	0.42	4	0.42	3	0.32
Control Environment (Temp.)	0.11	4	0.42	2	0.21	2	0.21	4	0.42
Production	0.05	5	0.26	3	0.16	3	0.16	4	0.21
Cost	0.11	4	0.42	4	0.42	3	0.32	4	0.42
Total	1.00		4.26		3.08		2.50		3.84

#### 4.6 Outcome concept

The result from the evaluation methods is the outcome concept that integrates each function solutions into one concept. The concept table (See Table 4.2) was used to present the selected solutions and also the other alternative solutions which were excluded by the Elimination matrices, the evaluations based on Go/No-Go screening and the Kesselring matrices. The list below is the selected solutions for the different functions. The concept table can be viewed in Appendix E.

##### Loading and Unloading core box

- Direction: Y-axis
- Method: Video player

##### Movement

- X-ray components movement: X-ray components move: X axis (left-right), Z axis (Up-down), Core box move - Y axis (In-out)

##### Transport solution

- Edge Protection - corner bumpers and edge bumpers
- Glass window / common panel protection - roll up door cover on one side
- Holding/Securing in vehicle - container solution, corner hole, forklift pockets
- Handling - container solution, corner hole, forklift pockets

##### Maintenance

- Cleaning - control air flow and air filter
- Sub system maintenance - separate partitions and cabinet

##### Environment

- Environment - heater, fan and dehumidifier and temperature and humidity controller

##### Layout

- System layout - The selected solution shown in the concept table

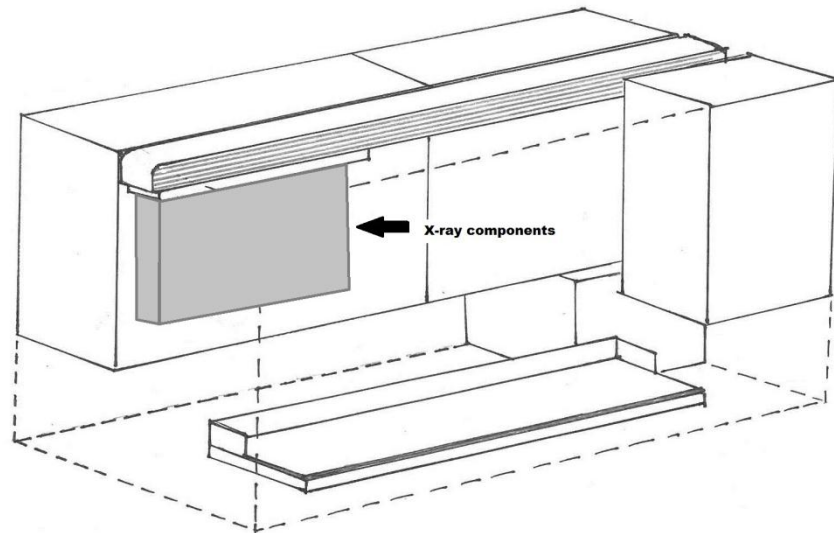
##### Safety

- Warning light position - four (one on each corner)
- Alarm system - emergency-stop and status light
- Security - key lock, magnetic lock, door sensor and key to start the machine

##### Cover

- Front hatch - swing door(opening down)

Next is a brief description of the outcome concept. Figure 4.8 illustrates the integrated concept. The core box loads into the instrument in the front side based on the solution called video player. The user puts the core box on the loading tray which is then pushed into the machine. The tray will slide to the start position then the instrument will start scanning. The X-ray components are attached to the actuator that moves from the left side to the right side of the machine. When one slot is finished scanned, the core box moves inward to start the analysis of the next slot. The analyzing process continues until the last slot. The number of slots varies depending on the dimensions of the core box and the size of the sample. For the standard core box, 1042 mm x 378 mm x 50 mm, which is the ideal dimensions for the developed machine, the number of slots per box is six or eight with the length of each slot being one meter.



**Figure 4.8: Outcome concept**

The outer design consists of the front hatch, feeding hatch and the touch screen for human – machine interaction. The front sides of the instrument are protected by the roll up door. The edge and the corners of the machine are mounted with bumpers to absorb any impact that might happen during transportation. With this container concept solution, the instrument can be placed steadily inside the vehicle. For the maintenance, the tray is a good solution to prevent dust and dirt from the samples, getting inside the machine. The airflow control and air filter help collect the dust and purify the air inside the machine. Because the instrument will be located near drill sites, it is possible that the ambient temperature would be extremely low, for example -40 degrees as in the case of the mine in Kiruna in the north of Sweden. In order to ensure that the instrument is operating in this temperature the temperature controller is a good solution. The heater can increase the temperature inside the instrument until it reaches the operating temperature. The dehumidifier can be used to adjust the air humidity.

The layout of the machine was designed with the aim to make it as compact as possible, but still fit all the sub-systems including the X-ray components, electronic storage cabinet, cooling system, high voltage generator and computer cabinet. The designed layout also accommodates the movement of the X-ray components and core box.

For the safety aspect, which is the most crucial criteria of instruments using X-ray equipment, the EU legislation clearly states that portable equipment that contains a closed radiation should have a well displayed warning light which is lit only when the radiation is present. By putting the warning lights on the corner of the instrument, it helps fulfill the legislation's requirement. If an unexpected event occurs, the instrument has an emergency stop button to end the process immediately. The most serious issue is the radiation safety. With regards to safety, the main design goal was to prevent the exposure to the radiation. The user is not allowed to handle the X-ray components while the equipment is scanning in any circumstance. The key lock, magnetic lock, door sensor and the use of a key to start the machine not only solves the radiation safety problem, but also limits access to the control panel, sub-system cabinet and sensitive components to an authorized person only. The magnetic lock was installed to secure the front hatch and feeding hatch. The lock responses to the safety PLC

signal which closes when the X-ray shutter is open. The door sensors detects that the hatch is in the right place and closes securely and gives permission to start the analyzing process.

The Front and feeding hatches of the instrument were designed with the intention not to allow the user to interfere with the X-ray components while the machine is in operation. The main reason why the machine has the hatches separately is to reduce the interference from the ambient environment as much as possible. Because the feeding hatch will be opened more frequently for loading and unloading the core box, compared to the front hatch that is opened only for maintenance of the components inside the analysis cage. The size of the feeding hatch is very small only slightly bigger than the core box.

After the outcome concept was concluded, the Failure mode and effects analysis (FMEA) was conducted in order to identify potential causes of failure. The results of the FMEA show that the components that have the highest risk priority number are the cooling system which may not have enough water lead to the overheat of the X-ray tube and the PLC system which risk of loose wires lead to a failure to control other system. The result of this method was used as a design aid in the next stage of refinement and final design. Table 4.5 shows the example of FMEA worksheet. The complete version will be shown in Appendix H.

**Table 4.5: The example of FMEA worksheet**

Item/ Function	Potential Failure mode	Potential Effects of Failure	Severity (S)	Potential Cause(s)	Occurrence (O)	Current controls	Detection (D)	Risk priority number (RPN)
Motor	Overloaded	Short circuit	4	Poor design / Overuse the machine	2	Regularly check the system	7	56
	Overheat	Stop working	7	Poor design / Overuse the machine	2	Regularly check the system	7	98
	No electricity	Stop working	8	Low voltage power supply failed	2	Maintenance list	3	48
Linear actuator	Slow movement	Wasting time	5	Poor maintenance / PLC error	2	Maintenance list	3	30
	Stuck	Stop working	8	Poor maintenance	2	Maintenance list	2	32
	No electricity	Stop working	8	Low voltage power supply failed	2	Maintenance list	2	32
Cooling system	Cooling liquid is freeze	overheat	8	Poor maintenance	2	Maintenance list	3	48
	Not enough water	overheat	8	Poor maintenance	5	Maintenance list	7	280
	Poor water flow	overheat	8	Pump failed	2	Maintenance list	7	112

\*The sensitive information was back out according to non-disclosure agreement.

## 5. Refinement

During the development of the final product, adjustments based on the evaluation methods always need to be made to improve the concept and to combining the good features of some alternative solutions that can be adapted for the product. This chapter will describe the refinement of the requirements specification and the refinement of the final product.

### 5.1 Refinement of requirements specification

The requirements of the instrument were modified during the development process either because of the hidden requirements that hadn't been realized at the beginning of the thesis, or new knowledge and information that was acquired during the process. These improvements include clarifying the requirements' statement, selecting a more accurate target level, enhancing the method of validation and evaluation, rating the requirement and adding the new requirements.

The specifications were reformulated for the purpose of justifying the requirements. For instance, the requirement that starts with, "Easy to ..." such as, "Easy to transport to the mining and exploration site", "Easy to change between transportation medium" and "Easy to load/unload the machine into the vehicle" were difficult to define whether it is easy or not. After the discussion the requirements were changed to "Possible to...". The changed requirements fulfill the basic understanding that the instrument should be able to do as stated in the requirements.

The target level was a tricky aspect because if the target level was too high to achieve, it might create a problem with the actual production of the machine. The preliminary solution was to set the target within a required range and the demand and wish target level. After carefully consideration the target level was changed to a more appropriate and accurate value for example, the analytical speed is 1mm/s to 10mm/s depending on the type of material, the analysis accuracy would be 100% accurate for the demand.

The validation and evaluation methods were explored to find the ways to improve the methods and procedures. For example to validate the mechanical robustness the instrument should be compared to other machines and equipment that are used in the mining industries.

For the safety function, it is stated in the initial requirement that the instrument should automatically shut down the X-ray tube when the hatch is open, but when considering the maintenance aspect, it might occur that the user needs to open some hatch, such as the computer cabinet or the electronic storage cabinet, while the machine is operating. The final product considers both the safety and maintenance aspects by designing an inner cage that prevents radiation leakage. In order to comply with this design, the requirement was added that the safety sensor be applied only to the hatch that leads to the X-ray tube so the user should still be able to open the electronic storage and computer hatch while operating.

The main specification change that affected the design is the size of the core box. The original intention of the design was to have a core box size of 1042 mm x 378 mm x 50 mm, but during the development, new information came to light that the standard size of the core box varies depending on the country that uses it. Thus the new dimension of the core box is, 1100 mm x 362 mm x 50 mm making the length of the new core box longer than the first one.



## 5.2 Refinement of the concept

The result from the evaluation methods is only the concept. To make it more feasible the refinement was needed to fill in the missing detail. Following are the concerns of the instrument and the solutions to overcome the problems. Some of the concerns were discovered during the 3D CAD modeling process.

### 5.2.1 Loading and unloading the core box and feeding hatch

For the method of loading and unloading the core box, the mechanism called “video player” was chosen. The concerns of this system are the lack of detail about the moving parts, how to open the hatch and how it works. The modified version of the “video player” integrates the strength of the “Drawer” concept. The improved concept satisfies all the concerns. The main features of the mechanism are the movement of the feeding tray and the hatch. The hatch was designed as a lifting door which could open upwards or downwards. After investigating both options the conclusion was that the best solution is to open downward because the top of the hatch could be used to attach the roller or other material to support the tray when loading the core box. The hatch should have a physical lock as well as the mechanism to prevent it from falling down. Research was conducted to find an example of a product that used such a system. The suppliers that can provide a similar type of product were found. The problem of this solution was realized later. Because of the size of the feeding hatch, it is not only impossible to make a lifting hatch that has a counter weight mechanism, but also extremely expensive for a motorized solution. After discussions with the stakeholders, the decision was made to reduce the complexity of the design by changing the lifting hatch to a normal swing hatch that opens downward. The decision not only solves the feeding hatch problem but also simplifies the space problem which is very tight inside the machine.

### 5.2.2 Cooling system

In the final product, the cooling system is placed in the back of the instrument next to the electronic storage cabinet. The drawing from the supplier indicates that if the cooling system is positioned in the back, the air inlet and outlet will be placed on the backside of the equipment as well. A ventilation problem might occur because the machine will be located close to the wall where there is restricted air flow. An alternative solution was to place the cooling system on the side of the machine. The only concern with this was the gap above the cooling system will be really tight because during the analysis the X-ray components are moving to the left ends and right ends of the instrument. The problems were solved when a new model of heat exchanger was discovered, which is very thin but longer. The decision was to put it on the top of the machine. Even though the total height of the machine will be increased, but when considering the advantage of having the air inlet and outlet on the top of the machine, this solution becomes the most suitable choice. The space at the back of the equipment can be used to install the water tank and pump because it is easier for maintenance when the water tank is separate from heat exchanger, for instance to refill the water, drain the water out of the system and cleaning. With this solution, the electrical cabinet can be expanded because the cooling system cabinet will use less space than in the first layout.

### 5.2.3 Core box dimension

The most critical issue was the discovery of the new dimensions of the core box. Since the machine was designed to use the standard core box (1042 mm x 378 mm x 50 mm), the new box is 1100 mm in length which can jeopardize the design of the machine. The reason behind

this is the transportation issue. The discussions came to the conclusion that the instrument should be limited to 1600 mm long. After exploring the design options, the stakeholders acknowledged that it is not possible to scan the whole length of the 1100 mm core box. The best option in this case is to design the machine that can load 1100 mm core box and scan the core sample as much as possible. In the final design the scanning result will miss a few millimeters at the right end of the core box.

## 6. Result

In this chapter, the final design of the instrument and the limitations of the design will be described. The topics focus on the feasible and ready to produce concept, the three-dimensional computer modeling (3D CAD) and the problems that arose during the 3D CAD modeling.

### 6.1 Final Design

After the refinement process, it is time to finalize the concept and design the components. The main parts of the instrument that were designed in this thesis consist of the profile structure, inner cage, cabinet, analysis equipment, feeding components, front hatch, feeding hatch and outer plate. The 3D CAD modeling was chosen as a prototyping tool to create the 3D model and production drawing.

#### 6.1.1 Profile structure

The profile structure is the aluminum frame that supports the inner cage and the outer plate. The total height of the instrument was expanded because the legs. The reason why the instrument needs the legs is for the transportation. The machine requires a gap between the body and the ground at least 130 mm in order to fit the forklift forks. Because the main function of the frame is to receive the load from the equipment, the beam that is used as the main structure is thicker than the rest. Triangular profiles were placed at the corners of the structure for aesthetics and for the installation of the warning lights on the top of the profile. Figure 6.1 shows a rendering of profile structure created by using the computer-aided design software, Autodesk Inventor.

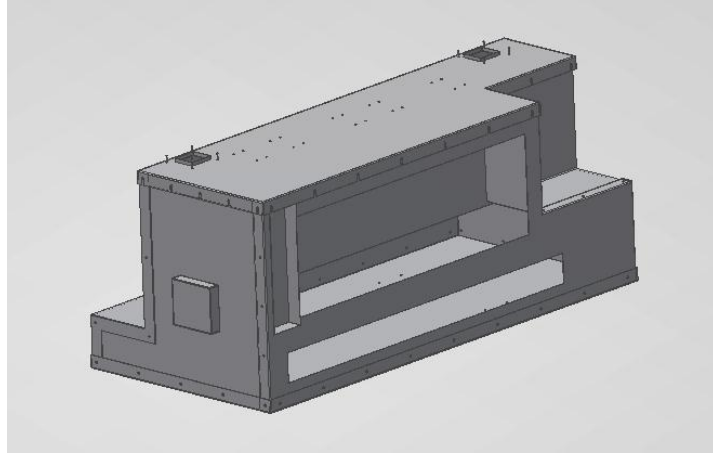


Figure 6.1: The profile structure

#### 6.1.2 Inner cage

The inner cage was designed to separate the X-ray beam from the user and other components. It is important that the primary beam of the X-ray cannot be reached by anyone at any time. The crucial factor that needs to be considered when designing this part was the radiation safety. The thickness of the metal sheet required is realized when the outer plate is included, the total thickness is sufficient to shield against radiation from the X-ray tube. The problem is when the user opens one of the cabinets during operation the total thickness of the metal plate is then reduced. The design solution is to use the thicker plate on the cabinet side. In

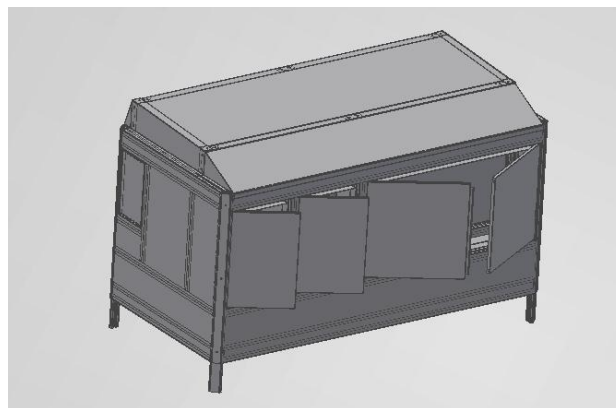
order to make sure that no radiation leaks out from the gap between the metal sheets, the metal sheets were designed to overlap in the corners of the cage. The open spaces for the cable inlet and outlet contains the light trap, the metal part that forces the radiation beam to bounce a couple of times, because the radiation reduces every time the beam bounces in the light trap. Figure 6.2 illustrates a rendering of the inner cage.



**Figure 6.2: Inner cage**

### 6.1.3 Cabinet

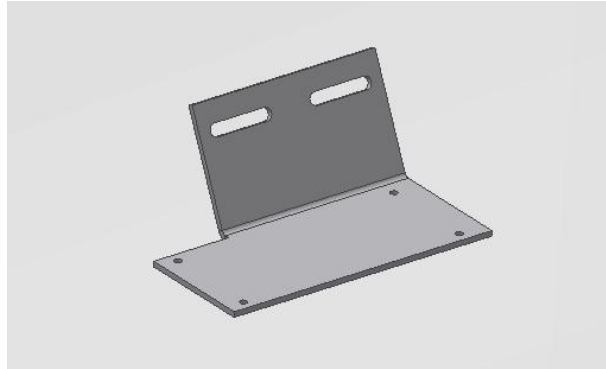
The Cabinet is the separate partition for the sub-systems which includes the electronic storage cabinet, high-voltage cabinet, water tank cabinet and computer cabinet. Each cabinet was designed to open from outside and cannot access to the analysis components. The cabinet doors have metal rims and flanges to prevent the water from slipping through the gaps between the cabinet and the door. The electronic storage, high-voltage and water tank cabinets are located at the back of the machine. To simplify the design and save production cost, instead of having a cage to install the components inside, the cabinets have only a back plate attached with the sub-system parts and the side wall to make partition within the cabinet. A concern was raised during the CAD modeling that because the electronic storage cabinet door opens very wide, the cabinet will take a lot of space at the back of the instrument. The best solution was to have two smaller cabinet doors. The computer cabinet is placed on the front side. The touch screen fastens onto the front plate and the cabinet door opens from the side of the machine. Figure 6.3 displays a rendering of the sub-system cabinets.



**Figure 6.3: Sub-system cabinets**

#### 6.1.4 Analysis equipment

The analysis equipment moves together in a left and right direction when the equipment scans the sample. Because the X-ray equipment is very fragile and valuable, extreme caution must be taken to prevent the X-ray equipment from colliding with other components. The main concern about the equipment bracket was the positioning. The flexibility to adjust the position is very important because it might happen that the user needs to adjust one of the components in order to get the most effective results. The brackets were designed to have slotted holes to allow for easy extensive adjustments. Figure 6.4 shows a rendering of the equipment bracket with slotted holes.



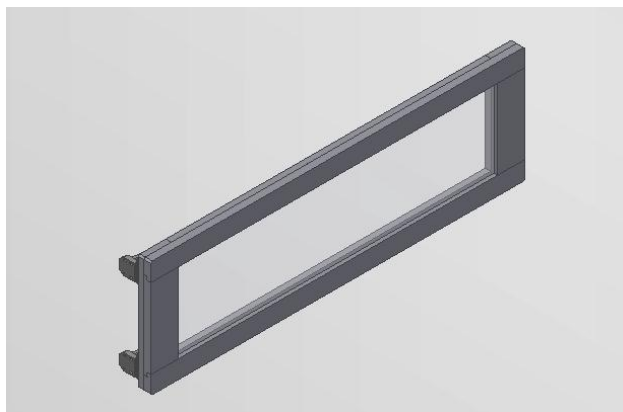
**Figure 6.4: Equipment bracket**

#### 6.1.5 Feeding components

The main function of the feeding components is to load and unload the core box. As mentioned in chapter 4.4.1, the movement of the core box is along the Y-axis direction. The tray moves in and out through the feeding hatch.

#### 6.1.6 Front hatch

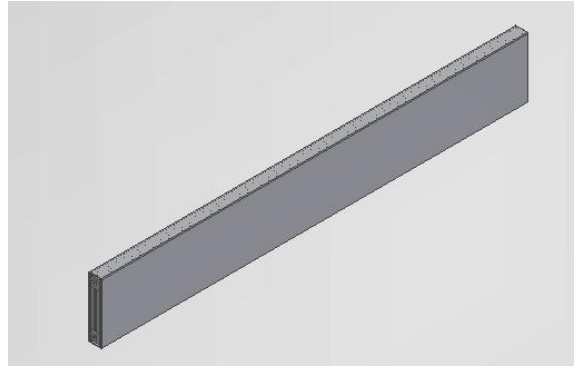
The front hatch is used for performing maintenance functions inside the inner cage such as cleaning the X-ray tube, changing the X-ray equipment and regular maintenance for the camera and laser sensor. The hatch is made with an aluminum frame and special lead glass, which makes it possible to look inside the machine. As mentioned in chapter 5.2.1 the open mechanism of the hatch was changed to a normal swing door. The hatch is kept shut by a magnetic lock which is activated during the analysis process and a key lock that allows only the authorized person to open the hatch. Figure 6.5 shows a rendering of the front hatch.



**Figure 6.5: Front hatch**

### 6.1.7 Feeding hatch

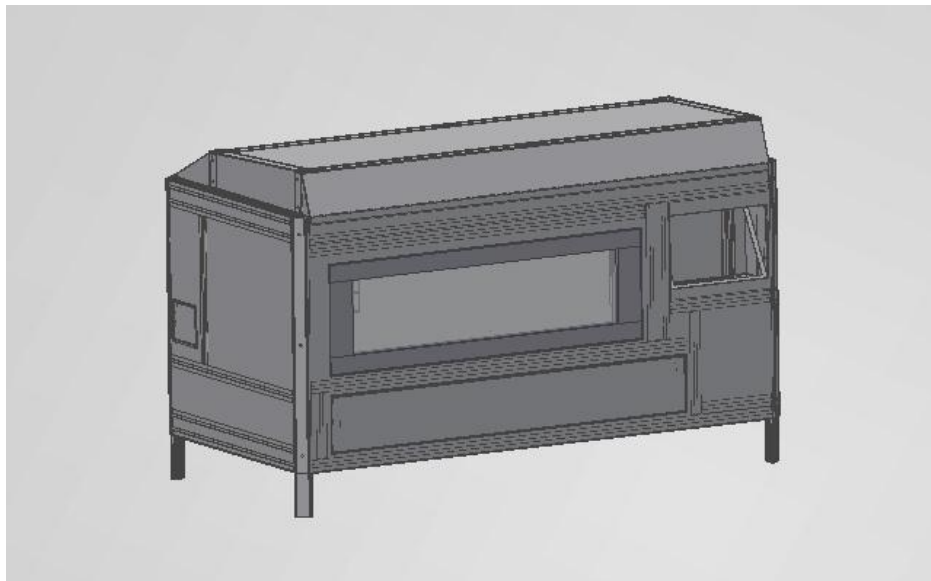
The feeding hatch is the most frequently opened hatch because it used for loading and unloading the samples. The radiation safety was the primary concern when designing this component. It is important to make sure that when the hatch is closed the inner wall and the hatch door are overlapping. The hatch is a swing door which opens downwards. Figure 6.6 shows a rendering of the feeding hatch.



**Figure 6.6: Feeding hatch**

### 6.1.8 Outer plate

The design of the outer plate was modified to match the refinement of the front hatch and feeding hatch. For example, the front plate was changed so that instead of having mounts with a slanted front hatch the plate just mounts with a horizontal front hatch. The warning lights were placed on the corners of the triangular profiles instead of being mounted on the wall. Finally, a modification of the roof was required because the heat exchanger will be positioned on top of the machine. The roof was intended to prevent the water from getting inside the machine that why it is sloped at a slight angle to make the water flow down from the roof. Figure 6.7 illustrates a rendering of the instrument.



**Figure 6.7: The instrument**

## 6.2 Limitations

Because of the time limit and the lack of information at the time, the design and CAD model of the instrument could not be fully completed. With the intention of reducing the uncertainty as much as possible, a list of limitations was made to indicate the tasks that could not be done or need to be investigated for more information. Below is the limitation list.

- The roll up door that covers the front hatch and touch screen cannot be placed inside the machine as per the intended design. Because of the space limit.
- The CAD model of the electrical components could not be completed because of the time limit and the list of electrical components were not finished either. However, the estimation of the components and initial sketches were created to confirm that all the electrical components can fit inside the electrical cabinet.
- The cooling system could not be finalized because new information from the supplier which had not been accounted for. An investigation needs to be done to explore alternative solutions.
- Some small detail could not be decided on until the selecting of the parts was done. For example, the fastening hole for the handle, the key lock and door catch on cabinet, the front hatch and feeding hatch could not be made because they were not selected at the time.

## 7. Discussion

This chapter will explain the discussions of both the thesis process and theoretical framework and the result. In the thesis process and theoretical framework, reflections on the development process and method used will be presented. The discussion about the fulfillment of specifications and final design will be discussed in the result.

### 7.1 Thesis process and Theoretical framework

The product development procedure outlined in this thesis follows the design methodologies including; establishing the requirements specification, identifying and expressing the functions, generating solution proposals and organizing alternatives, synthesis of concepts, evaluating with respect to selection criteria and refined selected processes. This approach was used as a guideline and timeframe for the thesis. The time plan of the process was divided into four phases to ensure that the thesis works in good progress and on the right track as it proceeds from stage to stage. In order to move on to the next phase, the results should have met and fulfill the requirement of the previous stage. The deliverable of the first stage is the list of requirements. The second stage requires the possible product concept. Finally, the requirement of the third stage is the potential concept. In summary, the design methodology provides a very useful approach for the development process.

The methods were selected and used as tools to facilitate meeting the goal of each process. The common question that arose during the process was which methods are suitable for the development of the instrument. For the function analysis process the flow model and function mean tree were chosen. Even though both methods have the same primary purpose which is to decompose the main function into sub function, the process flow model was used to show the flow of the input operand function and output operand. The function mean tree was used to map the functional domain and physical domain.

The use of the concept table was developed for this specific thesis. The intention of the use of method was to collect the solutions in one table then use the concept evaluation methods to evaluate each solution. The reason behind this is because the functions of the instrument have individual properties. The best way to simplify the evaluation process is to select the solutions from each function.

The choices of evaluation methods are also a discussion issue, for instance the evaluations based on Go/No-Go was applied in the concept screening process. The reason for using the Go/No-Go approach was because the stakeholders could be involved in the evaluation process and the discussions of pros and cons. This method is the fast and easy way to narrow down the concepts

### 7.2 Result

The result of the thesis is the CAD model and drawing of the instrument. Due to limited time and resources the final concept was modified to create the final design that is produce able and to reduce the manufacturing cost. The feeding hatch was one of the concerns during the development process. The first idea was to open it as a lift-up door with the opening mechanisms either motorized or counterweight. After consulting with several suppliers, it turned out that the concept was not feasible because the hatch is too small to install the



mechanism. In the end, the hatch was simplified and used as a swing door that opens downward.

Regarding the feasibility and the cost issue, the final design was presented to the manufacturing workshop that produced the first prototype. The meeting with the manufacturing workshop gave very useful information regarding the manufacturing. For instance, in the CAD model all the sheet metal can be assembled by using and indicating the accurate dimension. However for practical reasons the sheet metal plate cannot be used without a measure of tolerance. Hence, the design should consider the tolerances between two metal sheets. In the corner, the gap between the folded plate and the other plate should be at least equal to the thickness of the metal sheet plus 1 mm. and the tolerance between two plates in the normal assembly part should be 1mm. Finally the hole of the outer plate should be bigger than the hole of the inner plate, for instant if the inner plate uses M6 outer plate should use M8.

In summary, the result of the thesis has fulfilled the specification in a big extent. Even though there are some differences between the expect results and the final spec. These happen because of the requirements have been changed and the problem that discover during the development process. For example, as mention before the outcome concept of feeding hatch and front hatch will increase the complexity of the machine. The decision was to use a swing door instead.

Following, are the lessons learned during the development of this thesis.

- The requirements can change.  
During the thesis several requirements have been improved and changed. This is the uncertainty that cannot be avoided. Allowance and preparation should be made for this one needs to be aware of how these changes would affect future processes.
- The time plan is important.  
Sometimes the developer can lose sight of the purpose and focus on the wrong thing. The time plan is a good pacemaker and ideal tool for keeping all concerned on the right track. The deliverables of each stage can help clarify the aim of each phase.
- The best solution may be unfeasible.  
Even though one of the criteria is manufacturing ability, the evaluation could be based on the judgment of stakeholders who lack the expertise in that area. To ensure that the design is feasible, consultation with the experts is required.
- There is no perfect design in real world.  
In the computer-aided design program, the components can be created and assembled easily, but in reality the assembly process is more complicated. The design should consider practicalities such as the tolerance as well.

## 8. Recommendation

The developed product is the new developed equipment for a core box scanner. The first model was simplified due to time limitation and resources. For further development, there are many opportunities for improvement. This chapter will explain the recommendations and actions that could be taken.

First of all, some of the functions from the final concept were not applied in the final design. For example, for the transportation solution, the idea of adding corner bumpers, rolls up door and forklift pockets were proposed during the development process. The stakeholders also agreed with these concept solutions. Unfortunately the practical solution could not be identified within the thesis due to the time constraints. The suggestions are that a study of the method and material that would be suitable for those functions should be made.

The electrical components and electronic control system should be developed. The sketch of the electrical components that will be installed in the cabinet was made during the developmental process. But it could not be completed because the number of components could not be identified at that time. The sketch was based on the estimation of the number of components. Further action should be to identify the components and design the electronic control system by using the sketch as a guideline.

Safety from radiation is the most important issue. The recommendation is that the machine should be tested and measured for possible radiation leakage using a reliable method. The result should not exceed the limitations in the SSMFS 2008:25 Swedish Radiation Safety Authorities rules and general advice regarding radiography, and SSMFS 2008:40 Swedish Radiation Safety Authorities rules regarding usage of industrial equipment that contain closed radiation sources and X-ray tubes.

For further development, the instrument should be able to scan difference sizes of the core boxes. The study indicates that there are differences in the standard core box in various countries. For instance, the specification on the standards that are used in Sweden, Norway and Denmark are:

Sweden: 455 mm wide x 1050 mm long.

Norway: 343 mm wide x 1100 mm long.

Denmark: 400 mm wide x 1050 mm long.

The trend is that the core boxes are getting narrower because of the weight issue. The developed instrument has the ability to analyze a core box of length 1050 mm. For the next model the instrument should be able to analyze a core box 1100 mm long.

## 9. Conclusion

The purpose of the thesis was to generate a production ready concept of an X-ray instrument for analysis of rock samples for field use. The thesis has fulfilled its purpose. It has improved the function of the existing prototype by making it faster and easier for the user to scan core samples. The final concept includes the solution of a loading and unloading the core box, the movement of the X-ray equipment, transport solution, maintenance, control environment, layout, safety and outer design.

Product development methods and tools have been used during the thesis work. The Function analysis including the Process flow model and the Function-means tree, the Concept table, Concept evaluation - the Elimination matrix, the evaluation based on Go/No-Go screening and the Kesselring matrix, the Failure mode and effects analysis and Prototyping, were intensively applied and greatly contributed to the success of this thesis.

In conclusion, the developed instrument can analyze multiple samples in a standard core box. It is possible to easily transport the machine to the mine or exploration site. Regarding the maintenance, the machine was designed to ensure that the users can maintain the equipment easily. It can withstand the rough and tough environment. The layout of the machine was designed to be as compact as possible. Regarding safety, the concept was generated with respect to the Swedish Radiation Safety Authorities rules. Finally the outer design was proposed by the product designer.

The final design of the developed instrument includes profile structure, inner cage, sub-system cabinet, analysis equipment, feeding components, front hatch, feeding hatch and outer plate. The prototype was created by a computer-aided design program called Autodesk inventor. The CAD model of the instrument was presented to the manufacturing workshop to ensure that the design is possible to produce. For the sub-systems, consultation and advice was sought from an expert in the specific area.

## 10. References

- Beckhoff, B., Kanngießner, B., Langhoff, N., Wedell, R., & Wolff, H. (2006). *Handbook of Practical X-Ray Fluorescence Analysis*. Berlin: Springer.
- Bragsjö, N., Halonen, M., Johansson, C., Krpo, V., Sernevi, C., & Smajic, A. (2010). *Development and design of mobile and automatic drill core analysis machine*. Gothenburg: Chalmers University of Technology.
- Charantimath, P. M. (2009). *Total Quality Management*. Delhi: Pearson Education India.
- Masters Programme in Product Development. (2010). *Integrated Product Development*. Gothenburg.
- Moss, M. A. (1996). *Applying TQM to Product Design and Development*. New York: Marcel Dekker INC.
- Otto, K., & Wood, K. (2001). *Product Design - Techniques in Reverse Engineering and New Product Development*. Prentice Hall.
- Pahl, G., Wallace, K., & Blessing, L. (2007). *Engineering Design: A Systematic Approach*. Springer.
- Tague, N. R. (2005). *The quality toolbox*. American Society for Quality.
- Tomas From, S. (2011). Swedish Mining 2011. *Nordic Steel & Mining Review*, 195(7/11), 6-11.
- Ullman, D. G. (1944). *The Mechanical Design Process*. PA: McGraw Hill.
- Ulrich, K. T., & Eppinger, S. D. (2008). *Product Design and Development*. Singapore: Mc Graw Hill.

# Appendix A: Planning report

## Background

Companies within the mining industry perform exploration drilling in order to find new mineral resources. Currently, this process is associated with high investments and high risks mainly due to the extensive cost and time it takes to perform the analysis of the rock samples.

The first prototype was produce based on the concept from product development. The company decided to produce only a single core scanner to reduce the complexity of the prototype. The next prototype will improve the design and function of the first prototype and will be produce in the future based on the final concepts of the thesis.

## Purpose

The aim of the thesis is to generate feasible concepts of X-ray equipment based on the first prototype for performing field analysis of rock samples in mining and exploration applications. The new product will be capable of analyzing multiple samples in a standard core box.

## Objective

The objective is to develop and redesign the current prototype equipment with emphasis on following aspects. Operability, the developed equipment should be able to analyze more rock samples than existing prototype. Usability, the developed equipment should be easy to use according to ergonomics. Safety, the developed equipment should be safe to operate. Transportability, the developed equipment should be easy to transport. Environment, the developed equipment should be able to operate in the rough and tough environment. Design, the developed equipment should use small space and low weight.

The intended outcomes of the thesis are the concepts' solution of following functions, radiation shielding and cover, loading and unloading samples, movement and automation of samples, adjustment and integration of components, cooling system, maintenance and transport solution.

## Scope

Due to the limitation of this thesis, the thesis will focus on develop a concept of field analysis equipment. Following areas will be developed during this thesis.

- Construct the list of requirement's specification
- Generate, evaluate and select the concepts of load and unload, movement of samples and components, maintenance and transportation.
- Design the layout inside the machine
- Design the cover
- Create CAD models

The thesis is not including programing of PLC or control software and no physical production. This thesis will not go deep in the subsystem, only some suggestion on specific components' layout and requirement. The developed equipment will be presented with CAD models. The thesis will take 6 months to deliver the expected outcome.

### **Stakeholders**

The main people who working on this thesis are

Vasupol Kunavuti; Product developer

Mikael Arthursson; CTO at the company.

Annelie Blomdahl; CEO at the company.

Niklas Arthursson; Product designer

Hans Johannesson; Advisor and examiner at Chalmers University of Technology

### **Method**

The thesis will follow the product-development process. Begin with Pre-study phase, organizing and structuring how the project will flow. Research and conceptual analyses phase, studying the current prototype to find the problem and specify the requirement. Development phase is to generate, evaluate and select the concepts. Finally, refinement and deliverables phase, finalizing the concept and write the report.

In Pre-study phase, it is important to clearly state purpose and scope of the thesis and making agreement with the company. Thesis proposal was created in order to briefly describe the background, purpose, objective and preliminary time schedule of the thesis.

Research and conceptual analyses phase is to make an understanding of the concepts of existing prototype to be able to develop concept of the new prototype. Studying the sub system and component of the existing prototype and create component structure. Process flow model was made to illustrate input, process and output of the existing prototype.

Development phase, begin with forming requirement's specification and identifying function and problem. The problem/function relation was made to show interference between the functions and to find the most effect and effected function. Then generate the concepts and narrow its down by using evaluation method such as Pugh or Kesselring matrix and select the final concept. The final concept will be present to the geologist and worker in mining field in order to capture their perception and perspective about the equipment. The interview and other data collection method will be used.

Refinement and deliverables phase, the final concept will be refined and finalized. After that the CAD model will be created by using Autodesk inventor program. Finally, finish the report and presentation.

### Time schedule

The thesis is start in September 2011 and will end in March 2012.

ID	Task Name	Start	Finish	Duration	Oct 2011			Nov 2011				Dec 2011				Jan 2012				Feb 2012				Mar 2012																																		
					25-9	2-10	9-10	16-10	23-10	30-10	6-11	13-11	20-11	27-11	4-12	11-12	18-12	25-12	1-1	8-1	15-1	22-1	29-1	5-2	12-2	19-2	26-2	4-3	11-3	18-3	25-3																											
1	Study current prototype	2011-09-26	2011-10-07	10d	█																																																					
2	Create component structure	2011-09-26	2011-09-28	3d	█																																																					
3	Create Process flow model	2011-09-29	2011-10-03	3d	█																																																					
4	Establish requirement specification	2011-09-30	2011-10-07	6d	█																																																					
5	Identify the problems	2011-10-05	2011-10-07	3d	█																																																					
6	Create problem relation diagram	2011-10-07	2011-10-07	1d	█																																																					
7	Generate preliminary concept	2011-10-07	2011-11-04	21d	█																																																					
8	1st stage gate / Concepts presentation	2011-11-07	2011-11-07	1d						█																																																
9	User/Customer interviews based on first concept	2011-11-08	2011-11-14	5d							█																																															
10	Study maintenance requirement	2011-11-14	2011-11-18	5d							█																																															
11	Update list of requirements	2011-11-18	2011-11-22	3d							█																																															
12	Update concepts	2011-11-22	2011-11-29	6d							█																																															
13	2nd Stage gate	2011-11-30	2011-11-30	1d										█																																												
14	Concepts selection	2011-12-01	2011-12-08	6d											█																																											
15	Sketch final concepts	2011-12-09	2011-12-16	6d											█																																											
16	3th Stage gate	2011-12-16	2011-12-16	1d														█																																								
17	Refine selected concepts	2012-01-02	2012-01-20	15d															█																																							
18	Create CAD model	2012-01-20	2012-03-01	30d																			█																																			
19	Write report	2012-03-01	2012-03-30	22d																							█																															

### **Deliverables**

The following are the lists of deliverables in each phase and desirable outcome of the thesis.

Phase 1 Sep 20<sup>th</sup> – Nov 7<sup>th</sup>

- List of requirements
- Initial concepts
- Sketch of the product concepts

Phase 2 Nov 8<sup>th</sup> – Nov 30<sup>th</sup>

- Updated list of requirement
- Maintenance requirement list
- Sketch of updated product concept

Phase 3 Dec 1<sup>st</sup> – Dec 18<sup>th</sup>

- Final concept sketches

Phase 4 Jan 1<sup>st</sup> – Mar 31<sup>st</sup>

- Production drawing
- Sketches / Rendering
- Documentation
- Report

The final results of this thesis are the feasible concepts of instrument that can use for production, CAD models and report.



## Appendix B: Requirements specification

Rate	D/W	Requirements Specification	Target level	Validation	Evaluation / Verification
Product					
Performance					
4	D	Analytical speed	1mm/s to 10mm/s Depend on material	Measure the speed with time and distance travelled.	Consultation with expert
5	D	[REDACTED]	[REDACTED]	[REDACTED]	Repeatable test / Compare the result with lab result
	W	[REDACTED]	[REDACTED]	[REDACTED]	
4	D	[REDACTED]	[REDACTED]	[REDACTED]	Prototype testing/ Used photo to compare the position
	W	[REDACTED]	[REDACTED]	[REDACTED]	
5	D	Sample is not moving while analyze process			Photo
Weight					
3	D		Max 1000kg	Weigh using large scale used for vehicles.	Assessment using large scale.
	W		Max 400kg	Weigh using large scale used for vehicles.	Assessment using large scale.
Size					
4	W	The equipment should be able to put in the vehicle	180x110x75cm	Measure with measuring tape / stick	Assessment using CAD and measuring tape
5	W	Sound level	Max 90 dB	Measure with use of a dB meter	Relate to work place regulations
Power usage					
3	D	Operating	Max 6500 W	Measure using a volt and ampere meter	Consult with experts
	W	Stand by	Max 600 W	Measure using a volt and ampere meter	Consult with experts
Usage					
Set-up time					
3	W	Physical set-up	Max 2hr	Working standards	
4	D	System set-up	Max 5hr		
User Interface					
3	W	Touch screen monitor			Consult with user

## 42 Appendix B: Requirements specification

5	D	Operation manual			Consult with user
2	W	Service log			Consult with user
5	D	██████████		██████████	
4	D	Intuitive command			Consult with user
4	D	Automatic control system			Consult with user
4	D	Separate mode Operator interface (Automatic mode) and Geologist interface (Advance mode)			
4	W	Easy to change the analysis function			Consult with Geologist
User-friendly					
4	W	The geologist learning time	Max 24h		Engineering assessment
4	W	The operators learning time	Max 8h		Engineering assessment
Data					
5	D	Internal storage		Internal memory / internal hdd	Visual and functional assessment
4	D	External Storage		Integrated USB (pref. Type-A) connections for external drives available	Visual and functional assessment
5	D	Easy data transfer with authorization lock			
Ergonomic					
5	D	Meet standards		Work regulation	Simulation/ CAD/ Check AFS 1998:1 Belastningsergonomi
5	D	Machine reliability	96% operating time	Customer expectation	Mechanical calculations
3	W	Product lifetime	██████████	██████████	Component lifetime assessment
3	W	Mechanical robustness			Mechanical calculations
3	W	aesthetic design			Assessment using CAD
5	D	The analyzing process doesn't affect the sample			Consult with experts
Transportation					
5	D	The machine protection while transport			
5	D	Possible to transport to mining and exploration field			
3	W	Possible to change between transportation medium			
3	W	Possible to load/unload machine into the vehicle			
3	W	Stable the machine while transport			

Rock Sample (core box)					
		Type: Core			
		Geometrical form			
5	D	Cylinder core		Sample from core drilling	Test on prototype and/or consultation with Experts
5	W	Half cylinder core		Sample from core drilling	Test on prototype and/or consultation with Experts
		Weight			
5		Small iron core	0.208kg/100mm		
5		Large iron core	0.588kg/100mm		
		Standard core box			
5	D	Weight			
		Empty	3.1kg	Standard sample core box	Test on prototype and/or consultation with Experts
		Small iron core x 8 slot	19.74		
		Large iron core x 6 slot	38.38		
5	D	Size	104.2cm x 37.8cm x 5cm	Standard sample core box	Test on prototype and/or consultation with Experts
3	W	Powder form		Sample from RC drilling	Test on prototype and/or consultation with Experts
Maintenance					
4	W	Easy maintenance	1 year	Due to the need for maintenance of sub system (High voltage)	Consult with experts
4	D	Access to sub system for maintenance/exchange of part		Due to the need for maintenance of sub system	Consult with experts
4	W	Separate sub system partition		Due to the need for maintenance of sub system	Consult with experts
3	D	Inspection	monthly	Due to the need for maintenance of sub system (X-ray tube) / Check cooling pump every 3 months	Consult with experts
Environment					
4		Ambient Temperature			
	D		Max 50°C	Servicing in Australian climate	Prototype testing
	D		Min -20°C	Servicing in arctic climate	Prototype testing
5		Inside Temperature			

## 44 Appendix B: Requirements specification

	D	Operating	10°C to 25°C	The equipment are sensitive due to sub system	Prototype testing
	D	Storage	-20°C to 55°C	The equipment are sensitive due to sub system	Prototype testing
5	D	Humidity	35% to 80%RH	The equipment are sensitive due to sub system	Prototype testing, Dehumidifier
4	D	Resistance to water		The equipment are sensitive due to sub system	Prototype testing
4	W	Resistance to dust		The equipment are sensitive due to sub system	Consult with experts
4	W	Resistance to dirt		The equipment are sensitive due to sub system	Consult with experts
2	W	Prevent temperature rise/drop during load and unload core box		The equipment are sensitive due to sub system	Assessment using CAD
5	W	Prevent the water from the box from sensitive component			
3	W	Be able to drain any excess water out of the machine			
3		Corrosion resistant			
	D		10 years	Customer expectation	Engineering assessment
	W		15 years		Engineering assessment
4		Vibration resistance			
	D	Light vibrations during operation		Due to machinery in close vicinity	
	W	Unforeseen large vibration (shock)		Accidental drop	
4	W	Prevent sudden impact to X-ray tube			
<b>Production</b>					
2	W	Number of parts	Max 1000		Assessment using CAD
2	W	Production time	100 man hours		Assessment using DFA
<b>Safety</b>					
3	D	Automatically shut down x-ray tube when electrical problems: intermittent power, power surges, redundant wiring, and overloaded circuits			Prototype testing
5	D	the hatch is open		Safety sensor	Prototype testing
3	D	operation error		Emergency stop	Prototype testing
5	D	Emergency stop button			
5	D	Warning lamp	Green/Red/Yellow	Lights should be integrated and visible from 360 degrees around the machine.	

5	W	Warning indicator	
2	W	Warning alarm	Acoustic alarm
5	W	Only authorized person can operate the machine/ access the result	Cabinet lock
3	W	Separate switch between X-ray components and other components	

## Regulation

D	Basic safety standard		EU regulations	Assessment by mineral exploration experts
D	Mining standard		EU regulations	Assessment by Prospecting experts and ELSÄK-FS 1995:6)
D	Mineral exploration regulations		EU regulations	Assessment by mineral exploration experts
5	Radiation standard		Radiation Safety Authorities rules regarding usage of industrial equipment that contains closed radiation sources and X-ray tubes. (SSMFS 2008:4)	Discussion with Swedish Radiation Safety Authority, SSMFS 2008:4
D	Warning sign	Ionizing radiation, type description, the machine contain a X-ray tube, Shield the radiation before entry	SSMFS 2008:4, SSMFS 2008:25	
D	Radiation protection	Controlled 1 per year	SSMFS 2008:4	
D	Radiation dose rate	Not exceed 7,5 uSv/h where a person can pass by	SSMFS 2008:4	
		Not exceed 2,5 uSv/h where a person is permanently located	SSMFS 2008:4	
		Not exceed 2 uSv/h at 0,1 meters from the outer wall	SSMFS 2008:25	
D	Radiation source is not exposed to abnormal mechanical stress		SSMFS 2008:4	
D	Closed and locked shutter when the equipment is not used/ during the maintenance		SSMFS 2008:4	
D	Locked and fire safety storage area that contain radiation source		SSMFS 2008:4	
D	The system has two independent systems that hinder exposure to any person entering the space.		SSMFS 2008:25	

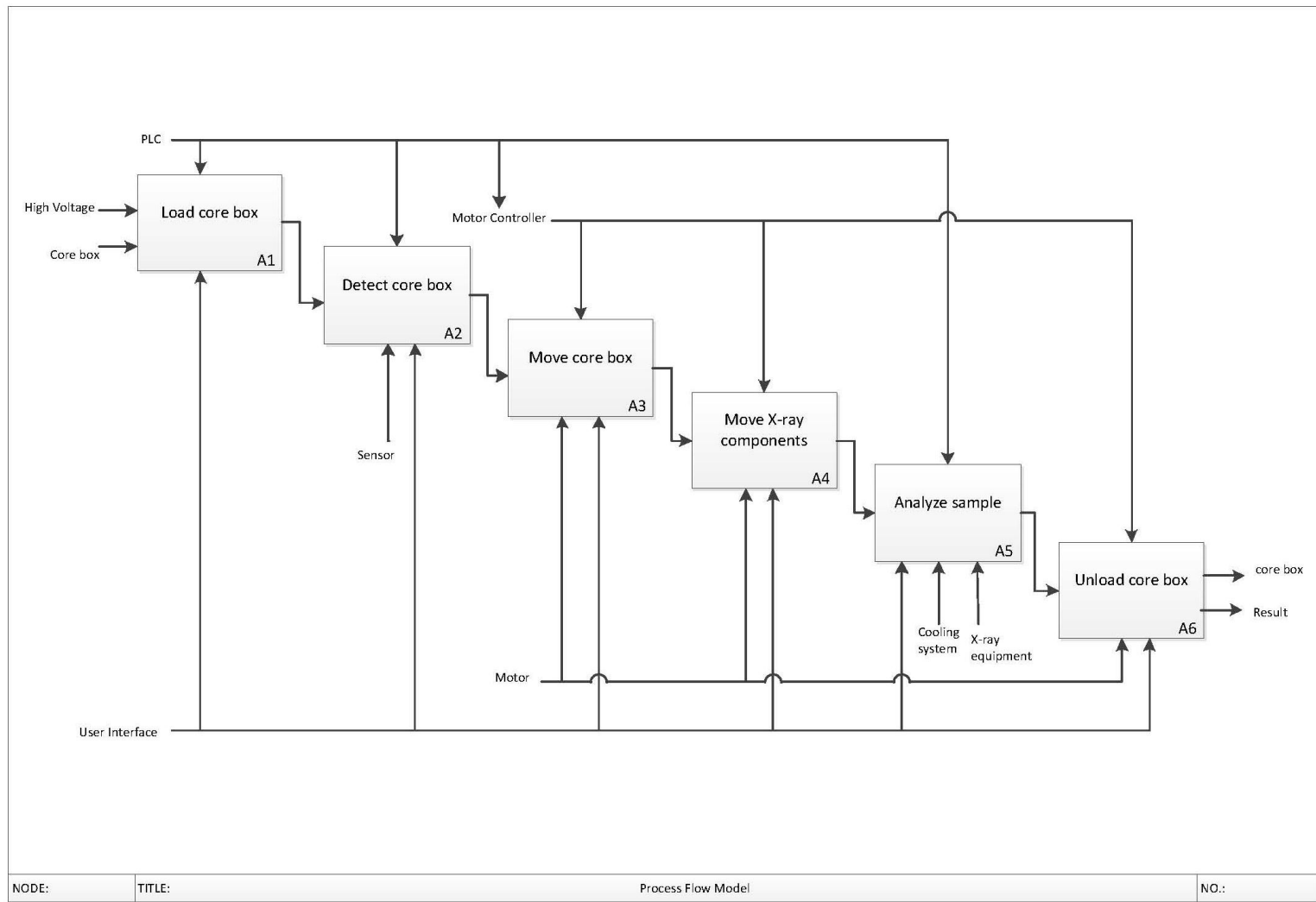
## 46 Appendix B: Requirements specification

		Instructions on where to find handling instructions regarding the closed space and the name of the contact person		SSMFS 2008:25	
	D	Warning light	lit only when the radiation is present	SSMFS 2008:25	
5	W	light trap			
	D	CE marking regulation		The CE marking is mandatory in most parts of Europe.	Assessment using FMEA, 89/106/EEC and 2006/42/EC
Additional function					
2	W	Inspection table			
2	W	Stand			
2	W	Wheel			
4 Cost					

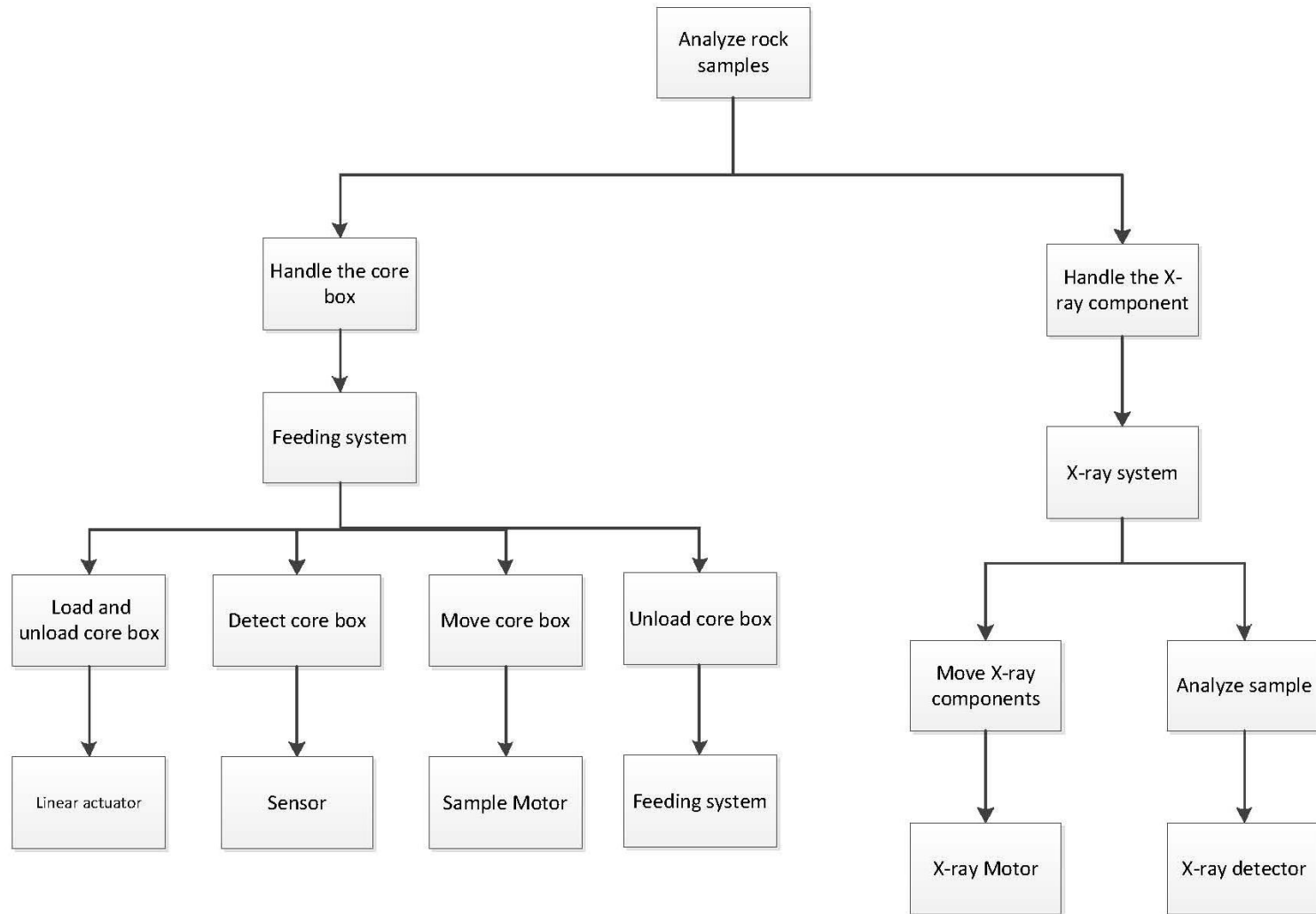
\*The sensitive information was back out according to non-disclosure agreement.

# Appendix C: Functional analysis

## Process flow model

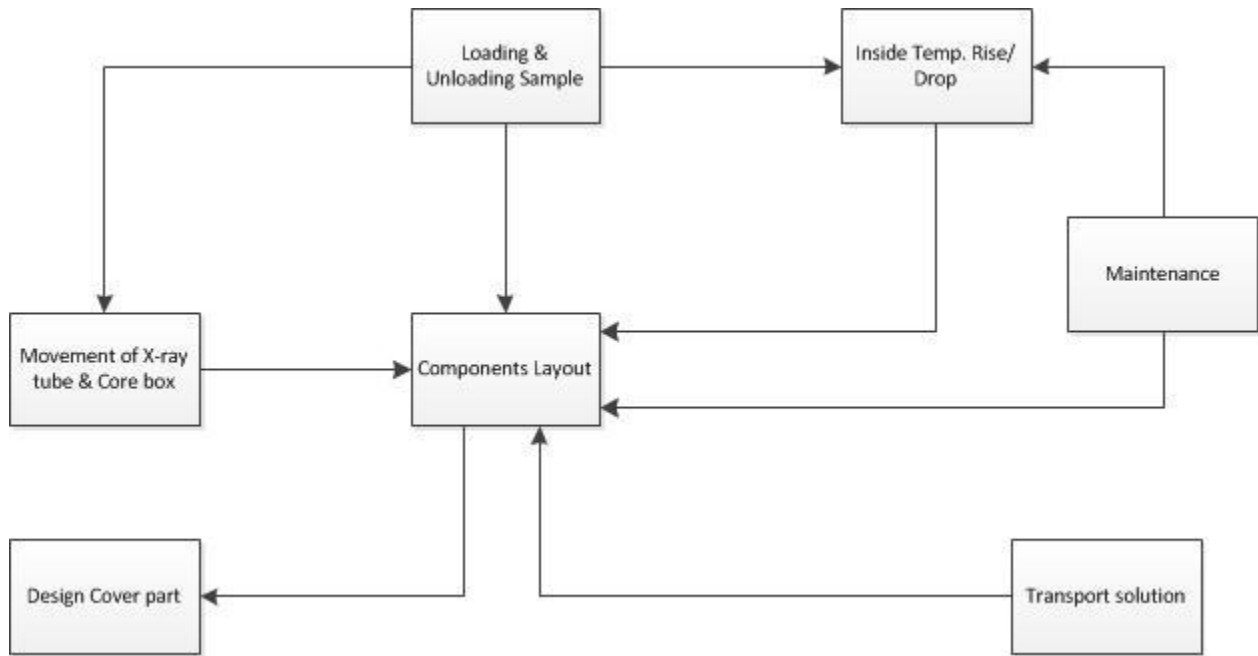


Function-mean tree

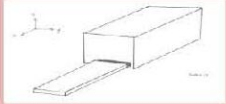

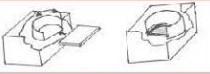


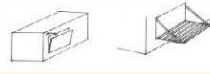








# Appendix D: Relations diagram

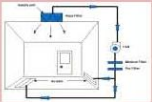
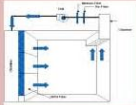
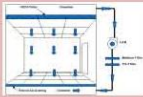


## Appendix E: Concept table

Function/concept	1	2	3	4	5	6
<b>1. Loading and unloading the core box</b>						
1.1 Direction	X-axis 	Y-axis 				
1.2 Method	Rotation 	Lift up 	Video player 	The oven 	Sledge 	Drawer 
<b>2. Movement</b>						
2.1 X-ray components movement	1. X-ray components move: X axis (left-right), Z axis (Up-down), Core box move: Y axis (In-out)	2. X-ray components move: Y axis (In-out), Z axis (Up-down), Core box move: X axis (left-right)	3. X-ray components move: Z axis (Up-down), Core box move: X axis (left-right), Y axis (In-out)			
<b>3. Transport solution</b>						
3.1 Edge Protection	Nothing	Corner bumper	edge bumper			

3.2 Window / common panel protection	Roll up door covers one side	two Roll up doors seperately	Shutter
3.3 Holding/Securing in vehicle	Container solution, corner hole, forklift pockets 	Rail + Rack 	Hole + Hook
3.4 Handle	Container solution, conner hole, forklift pockets 	Portable	Nothing


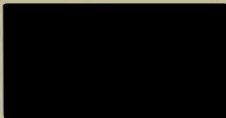
4. Maintenance

4.1 Cleaning	Tray	Control Air flow	air filter	Clean room (Turbulent Mixed Flow) 	Clean room (Horizontal Laminar Flow) 	Clean room (Vertical Laminar Flow) 
4.2 Sub system maintenance	Separate patition	Cabinet	Nothing			

5. Environment

5.1 Control Environment	Air Curtain	Control Air flow	Heater, Fan and Dehumidifier	Temperature and Humidity Controller
-------------------------	-------------	------------------	------------------------------	-------------------------------------

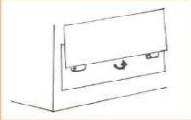
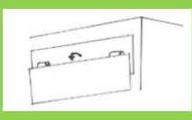
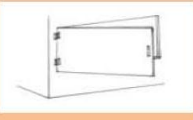
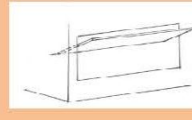
6. Layout

6.1 System layout	1 	2 
-------------------	--	---

7. Safety

7.1 Warning light position	one on top	four in the corner		
7.2 Alarm system	Emergency-stop	Status light	Alarm sound	
7.3 Security	Key lock	magnetic lock	Door sensor	Use key to start machine

8. outer design

8.1 Front hatch	1 	2 	3 	4 	5 Normal door
-----------------	--	--	--	--	---------------

Exclude by Elimination matrix
  Exclude by Evaluation based on Go/No-Go
  Exclude by Kesselring matrix
  Selected concepts

\*The sensitive information was back out according to non-disclosure agreement

## Appendix F: Elimination matrix

### 1. Loading and Unloading the core box

#### 1.1 Direction

Solution	Selection Criteria					Remarks	Decision
	A	B	C	D	E		
1. X-axis	-					Incompatible with core box movement	-
2. Y-axis	+	+	+	+	+		+

#### 1.2 Method

Solution	Selection Criteria					Remarks	Decision
	A	B	C	D	E		
1. Rotation	+	-				Unfeasible/Bigger than requirement	-
2. Lift up	+	+	-			Incompatible with layout	-
3. Video player	+	+	+	+	+		+
4. The oven	+	+	+	+	+		+
5. Sledge	+	+	+	?			?
6. Drawer	+	+	+	+	+		+

### 2. Movement

#### 2.1 X-ray components movement

Solution	Selection Criteria					Remarks	Decision
	A	B	C	D	E		
1. X-ray components move: X axis (left-right), Z axis (Up-down), Core box move: Y axis (In-out)	+	+	+	+	+		+
2. X-ray components move: Y axis (In-out), Z axis (Up-down), Core box move: X axis (left-right)	+	+	-			Incompatible with layout	-
3. X-ray components move: Z axis (Up-down), Core box move: X axis (left-right), Y axis (In-out)	+	+	-			Incompatible with layout	-

## 3. Transport solution

## 3.1 Edge Protection

Solution	Selection Criteria					Remarks	Decision
	A	B	C	D	E		
1. Nothing	+	-				Machine require protection during transportation	-
2. Conner bumper	+	+	+	+	+		+
3. Edge bumper	+	+	+	+	+		+

## 3.2 Window glass / common panel protection

Solution	Selection Criteria					Remarks	Decision
	A	B	C	D	E		
1. Roll up door cover one side	+	+	+	+	+		+
2. Two Roll up door separately	+	+	+	+	+		+
3. Shutter	+	+	-			Unfeasible	-

## 3.3 Holding/Fixed in vehicle

Solution	Selection Criteria					Remarks	Decision
	A	B	C	D	E		
1. Container solution, Conner hold, forklift pockets	+	+	+	+	+		+
2. Rail + Rack	+	+	+	+	+		+
3. Hole + Hook	+	+	+	+	+		+

## 3.4. Handle

Solution	Selection Criteria					Remarks	Decision
	A	B	C	D	E		
1. Container solution, corner hold, forklift pockets	+	+	+	+	+		+
2. Portable	+	+	?				?
3. Nothing	+	!					!

## 4. Maintenance

## 4.1 Cleaning

Solution	Selection Criteria					Remarks	Decision
	A	B	C	D	E		
1. Tray	+	+	+	+	+		+
2. Pressure	+	+	+	+	+		+
3. Air filter	+	+	+	+	+		+
4. Clean room (Turbulent Mixed Flow)	+	+	+	-		Will be considered in further develop	-
5. Clean room (Horizontal Laminar Flow)	+	+	+	-		Will be considered in further develop	-
6. Clean room (Vertical Laminar Flow)	+	+	+	-		Will be considered in further develop	-

## 4.2 Sub system maintenance

Solution	Selection Criteria					Remarks	Decision
	A	B	C	D	E		
1. Separate partition	+	+	+	+	+		+
2. Cabinet	+	+	+	+	+		+
3. Nothing	+	-					-



## 5. Environment

## 5.1 Control Environment

Solution	Selection Criteria					Remarks	Decision
	A	B	C	D	E		
1. Air curtain	+	+	?				?
2. Control pressure inside and outside the machine	+	+	?				?
3. Heater	+	!				Warm environment?	!
4. Temperature and Humidity Controller	+	+	+	+	+		+

6. Layout

6.1 System layout

Solution	Selection Criteria					Remarks	Decision
	A	B	C	D	E		
1 	+	+	+	+	+		+
2 	+	+	+	+	+		+

\*The sensitive information was back out according to non-disclosure agreement

Criterion A: Solution proposals are compatible with the overall task and one another.

Criterion B: The solution proposals fulfill the demands of the requirements list.

Criterion C: The solution proposals are realizable in respect of performance and layout.

Criterion D: The solution proposals are expected to be within permissible cost

Criterion E: Compatible with safety standard and introduce favorable ergonomic conditions

Selection Criteria

(+) Yes

(-) No

(?) Lack of information

(!) Check requirement list

Decision

(+) Pursue solution

(-) Eliminate solution

(?) Collect information

(!) Check requirement list for changes



## Appendix G: Kesselring matrix

### 1. Loading and unloading core box

Criteria	Rate	Weight
Performance (Speed)	4	0.11
Weight	3	0.08
Size	4	0.11
Ergonomics/Safety	5	0.13
Reliability	5	0.13
aesthetic design	3	0.08
Maintenance	4	0.11
Control Environment (Temp.)	4	0.11
Production	2	0.05
Cost	4	0.11
<b>Total</b>	<b>38</b>	<b>1.00</b>

Criteria	Weight (W)	Video player		The oven		Sledge		Drawer	
		Value (V1)	Weighted Value (W*V1)	Value (V2)	Weighted Value (W*V2)	Value (V3)	Weighted Value (W*V3)	Value (V4)	Weighted Value (W*V4)
Performance (Speed)	0.11	5	0.53	4	0.42	2	0.21	4	0.42
Weight	0.08	5	0.39	3	0.24	3	0.24	5	0.39
Size	0.11	4	0.42	3	0.32	3	0.32	4	0.42
Ergonomic/Safety	0.13	4	0.53	2	0.26	1	0.13	3	0.39
Reliability	0.13	5	0.66	3	0.39	2	0.26	4	0.53
aesthetic design	0.08	4	0.32	3	0.24	3	0.24	4	0.32
Maintenance	0.11	3	0.32	4	0.42	4	0.42	3	0.32
Control Environment (Temp.)	0.11	4	0.42	2	0.21	2	0.21	4	0.42
Production	0.05	5	0.26	3	0.16	3	0.16	4	0.21
Cost	0.11	4	0.42	4	0.42	3	0.32	4	0.42
<b>Total</b>	<b>1.00</b>		<b>4.26</b>		<b>3.08</b>		<b>2.50</b>		<b>3.84</b>

## 5. Control Environment

Criteria	Rate	Weight
Control inside temperature	5	0.19
Control Humidity	5	0.19
Prevent temperature rise/drop during load and unload core box	2	0.07
Reliability	5	0.19
Maintenance	4	0.15
Production	2	0.07
Cost	4	0.15
<b>Total</b>	<b>27</b>	<b>1.00</b>

Criteria	Weight (W)	Air curtain		Control Air flow		Heater, Fan and Dehumidifier		Temperature and Humidity Controller	
		Value (V1)	Weighted Value (W*V1)	Value (V2)	Weighted Value (W*V2)	Value (V3)	Weighted Value (W*V3)	Value (V4)	Weighted Value (W*V4)
Control inside temperature	0.19	1	0.19	3	0.56	4	0.74	5	0.93
Control Humidity	0.19	1	0.19	1	0.19	5	0.93	5	0.93
Prevent temperature rise/drop during load and unload core box	0.07	5	0.37	4	0.30	2	0.15	3	0.22
Reliability	0.19	4	0.74	3	0.56	4	0.74	4	0.74
Maintenance	0.15	4	0.59	4	0.59	3	0.44	4	0.59
Production	0.07	4	0.30	2	0.15	3	0.22	4	0.30
Cost	0.15	4	0.59	4	0.59	5	0.74	2	0.30
<b>Total</b>	<b>1.00</b>		<b>2.96</b>		<b>2.93</b>		<b>3.96</b>		<b>4.00</b>

## 8. Front Hatch

Criteria	Rate	Weight
Access to sub system	4	0.12
Ergonomics	5	0.15
Safety (Radiation)	5	0.15
Reliability	5	0.15
aesthetic design	4	0.12
Maintenance	4	0.12
Production	2	0.06
Cost	4	0.12
<b>Total</b>	<b>33</b>	<b>1.00</b>

Criteria	Weight (W)									Normal door	
		Value (V1)	Weighted Value (W*V1)	Value (V2)	Weighted Value (W*V2)	Value (V3)	Weighted Value (W*V3)	Value (V4)	Weighted Value (W*V4)	Value (V5)	Weighted Value (W*V5)
Access to sub system	0.12	5	0.61	5	0.61	4	0.48	5	0.61	4	0.48
Ergonomic	0.15	4	0.61	5	0.76	4	0.61	3	0.45	1	0.15
Safety (Radiation)	0.15	4	0.61	4	0.61	2	0.30	4	0.61	4	0.61
Reliability	0.15	4	0.61	4	0.61	4	0.61	4	0.61	4	0.61
aesthetic design	0.12	4	0.48	4	0.48	4	0.48	4	0.48	3	0.36
Maintenance	0.12	4	0.48	4	0.48	4	0.48	3	0.36	4	0.48
Production	0.06	3	0.18	3	0.18	4	0.24	3	0.18	4	0.24
Cost	0.12	4	0.48	4	0.48	4	0.48	4	0.48	5	0.61
<b>Total</b>	<b>1.00</b>		<b>4.06</b>		<b>4.21</b>		<b>3.70</b>		<b>3.79</b>		<b>3.55</b>



Motor	Overloaded	Short circuit	4	Poor design / Overuse the machine	2	Regularly check the system	7	56
	Overheat	Stop working	7	Poor design / Overuse the machine	2	Regularly check the system	7	98
	No electricity	Stop working	8	Low voltage power supply failed	2	Maintenance list	3	48
Linear actuator	Slow movement	Wasting time	5	Poor maintenance / PLC error	2	Maintenance list	3	30
	Stuck	Stop working	8	Poor maintenance	2	Maintenance list	2	32
	No electricity	Stop working	8	Low voltage power supply failed	2	Maintenance list	2	32
Cooling system	Cooling liquid is freeze	overheat	8	Poor maintenance	2	Maintenance list	3	48
	Not enough water	overheat	8	Poor maintenance	5	Maintenance list	7	280
	Poor water flow	overheat	8	Pump failed	2	Maintenance list	7	112
PLC	loose wires	Failure to control other system	8	Poor maintenance	5	Maintenance list	7	280
	redundant wiring	Failure to control other system	3	Human error	3	User manual/Training	7	63
Emergency Stop	Does not stop the machine	Damage to human or machine	9	Safety PLC error	6	Regularly check the system	5	270
	Button stuck or faulty	Cannot stop the machine	9	Poor maintenance	3	Maintenance list	2	54
	Not connected to Safety PLC	Cannot stop the machine	9	loose wires/Human error	6	Maintenance list	2	108
Status light	Delay of light turning on	User does not notice the status of the machine	6	PLC error/ Light failed	5	Regularly check the system	2	60
	Broken light bulb	No status light	6	Crush with other components	5	Maintenance list	1	30
	Wrong light turning on	Misunderstanding lead to an accident	7	PLC error	5	Regularly check the system	2	70
Computer	Overheat	Short circuit	5	Overuse	2	Regularly check the system	2	20
	Unexpected restart	Wasting time	5	Computer failed/ error	2	Maintenance list	2	20
	Unexpected shut down	Machine stop working	7	Computer failed/ error	2	Maintenance list	2	28

62 Appendix H: FMEA worksheet

LED Lamp	Delay of light turning on	Wasting time	4	PLC error/ Light failed	2	Regularly check the system	2	16
	Broken light bulb	Cannot take pictures	5	Crush with other components	2	Maintenance list	1	10
Magnetic lock	No electricity	Cannot lock the door	6	High voltage power supply failed	5	Maintenance list	2	60
	Not connect to Safety PLC	Cannot control door lock	5	Loose wires	3	Maintenance list	2	30
[REDACTED]	Not connect to computer	[REDACTED]	4	Loose wires	2	Maintenance list	2	16
	Delay	Wasting time	3	PLC error	5	Regularly check the system	4	60
	[REDACTED]	[REDACTED]	4	Light failed	4	Maintenance list	2	32
	No electricity	Not working	5	High voltage power supply failed	2	Maintenance list	2	20
	[REDACTED]	[REDACTED]	3	Poor maintenance	7	Maintenance list	5	105
Touchscreen	Does not detect when user touching screen	Cannot give the command to the machine	4	light sensitive/ Touchscreen failed	8	Maintenance list	1	32
	Not connect to computer	Cannot control the system	5	Loose wires	5	Maintenance list	4	100
Chassis	Crack	Radiation leak	9	Poor material selection	2	Regularly check radiation level	9	162
	Deform	Radiation leak	9	Poor material selection	2	Regularly check radiation level	9	162
	Not completely jointed	Radiation leak	9	Poor design	2	Regularly check radiation level	8	144
Front hatch	Fall down	User's injury/ Machine damage	8	Lock is not working	2	Regularly check the system	2	32
	leakage	radiation leak	9	Poor design	2	Regularly check radiation level	8	144
	Stuck because of friction	Cannot close the hatch	7	Poor maintenance	5	Maintenance list	2	70
Feeding hatch	Fall down	User's injury/ Machine damage	8	Lock is not working	2	Regularly check the system	2	32
	leakage	Radiation leak	9	Poor design	2	Regularly check radiation level	8	144
	Stuck because of friction	Cannot close the door	7	Poor maintenance	5	Maintenance list	2	70

\*The sensitive information was back out according to non-disclosure agreement.

Severity

Rating	Meaning
1	No effect
2	Very minor (only noticed by discriminating customers)
3	Minor (affects very little of the system, noticed by average customer)
4/5/6	Moderate (most customers are annoyed)
7/8	High (causes a loss of primary function; customers are dissatisfied)
9/10	Very high and hazardous (product becomes inoperative; customers angered; the failure may result unsafe operation and possible injury)

Occurrence

Rating	Meaning
1	No known occurrences on similar products or processes
2/3	Low (relatively few failures)
4/5/6	Moderate (occasional failures)
7/8	High (repeated failures)
9/10	Very high (failure is almost inevitable)

Detection

Rating	Meaning
1	Certain - fault will be caught on test
2	Almost Certain
3	High
4/5/6	Moderate
7/8	Low
9/10	Fault will be passed to customer undetected